

UC Davis
IDAV Publications

Title

Signal Monitoring on the Downlink of Cellular Communications with Interference Cancellation

Permalink

<https://escholarship.org/uc/item/6t0470x2>

Authors

Golanbari, Michael
Ford, Gary

Publication Date

1999

Peer reviewed

Signal Monitoring on the Downlink of Cellular CDMA Communications with Interference Cancellation

Michael Golanbari and Gary E. Ford
Center for Image Processing and Integrated Computing and
Dept. of Electrical and Computer Engineering
University of California, Davis, CA 95616
{golanbar,ford}@ece.ucdavis.edu

Abstract — We develop and evaluate receiver algorithms for the detection of signals transmitted via the *downlink* of a cellular system modeled after the IS-95 standard for code-division multiple-access (CDMA) communications. Multiuser detectors on board airborne and terrestrial mobile signal monitors attempt the simultaneous detection, in a single receiver, of all communication signals transmitted by the base station of interest. Due to the detrimental effects of transmitter, receiver and channel nonlinearities, very fast multipath fading, Doppler spread, additive white Gaussian noise, and intercell multiple-access interference, the user signals are de-orthogonalized. This leads to performance degradation in conventional receivers that is too severe, especially when the powers of some of the interfering users are dominant. In order to improve upon the performance of conventional matched filter receivers, this article focuses on the development and evaluation of relatively simple successive interference canceling (SIC) algorithms. The techniques we have developed can be used to enable successful interception of CDMA signals; to relax the strict requirements on power control; and to improve the capacity of CDMA systems.

I. INTRODUCTION

The high deployment rate of new IS-95 cellular CDMA systems in the US and abroad, and the emergence of CDMA as a strong candidate for future universal personal communications networks, necessitate the design and implementation of practical, interference-resilient demodulators for co-channel spread-spectrum signals. In addition, the stringent requirements on power control imposed by the IS-95 system to combat the near-far problem may be relaxed if multiuser detection is employed. This work exploits this observation and proposes to apply multiuser detection to the signals transmitted on the downlink of IS-95.

Although the general problem of signal interception has received some attention in the literature [1], and even though several multiuser detection schemes have been previously

applied to CDMA signals [2–4], to our knowledge very little has been published on the interception of multiuser IS-95 signals. The few exceptions include [5, 6], which did not consider SIC nor airborne interception. Reference [3] has considered successive interference cancellation with convolutional forward error correction coding and decoding, showing improved performance compared to the use of conventional matched filter receivers. Reference [7] has demonstrated performance gains for multiuser detection on the forward link of a CDMA system, but it did not consider SIC. Furthermore, most of the previously published performance results, including [2–6], do not consider the non-linear, very fast fading channel models which we investigate here, and they concentrate on the reverse link of CDMA communications. These results are not fully applicable to the scenario of signaling on the forward channel of IS-95 because the transmitter and the propagation channels which we investigate are substantially different than those which have been previously considered in the literature for the reverse link. The problem offers some new twists – e.g., the particular structure of IS-95 signals, the fact that from the point of view of the interceptor, power control increases the dynamic range and worsens the near-far effect, and the fact that we are interested in intercepting the signals of **all** the users in a desired cell, rather than only a single user. Numerous articles, such as [7–9] reported on the relatively unsatisfactory performance of some conventional matched filter receivers in very harsh downlink propagation channels without multiuser detection and/or antenna diversity. This motivates the need to investigate multiuser receivers which are specifically designed for more practical and realistic models of the downlink of the IS-95 system, including transmitter, channel and receiver nonlinearities, and severe fading conditions which may be associated with the downlink under certain circumstances.

The techniques we have developed can be used for surveillance and/or reconnaissance of CDMA signals for law enforcement, defense, cellular fraud management, etc.;

to improve the capacity of existing and proposed ground satellite and other aeronautical communications platforms; and to potentially relax the stringent requirements on power control imposed by the IS-95 system.

III. SIGNAL AND RECEIVER MODELS

The signal model is based on the IS-95 CDMA cellular system. Each cell has a common pilot channel which is transmitted by the base station. The user signals are orthogonalized, as all signals emanating from the same base station transmitter are spread by orthogonal Walsh codes and they are all synchronized with each other. When the propagation path between the base station of interest and the interceptor is ideal, so that the *received* traffic channels are orthogonal and synchronous, multiuser detection is not necessary on the forward link, as a bank of simple correlation (matched filter) receivers is optimal.

We consider channel models in which this signal orthogonalization is not preserved. The communications between the base station and the airborne interceptor are assumed to take place over a Rician flat-fading mobile satellite channel, while the communications between the base station and a land-based mobile interceptor are assumed to take place over a Rayleigh frequency-selective fading mobile channel. For both channels, we assume very fast time-varying fading which is independent from each group of n chips to all other groups of n chips, with $n < 64$. We also incorporate, in all our simulations, the effects of transmitter, receiver and channel nonlinearities. The nonlinearities and rapid fading act to effectively destroy the orthogonality of the traffic channels on the forward link. The detrimental effects of nonlinearities and fast fading are exacerbated by the fact that Walsh codes are, in general, non-strongly orthogonal [2, p. 11–12]. Both propagation channels introduce multipath interference, log-normal shadowing, path loss, Doppler spread, intracell interference, intercell interference and additive white Gaussian noise.

Through power control in the downlink, the power transmitted to close-in portables is reduced, while the signal to intercell interference plus noise (SINR) requirements of all portables are satisfied, increasing the overall capacity [8, 10]. From the point of view of the airborne or land-based (terrestrial) interceptor, power control on the forward link can be a major problem, because the higher power allocated by the base station to transmit to mobiles which are further away from the base station can overwhelm the power transmitted by the base to mobiles which are close to the base. Hence, *from the point of view of the interceptor*, this particular power control scheme is not beneficial if the interceptor employs a conventional matched filter receiver which is not near-far resistant. However, as we show in the sequel, the power control scheme is beneficial if the interceptor employs successive cancellation, because the successive interference canceling detectors perform better when the signals

are of distinctly different powers [2].

For frequency-flat Rician fading (satellite or airborne interceptor), the parameters for the baseband channel models are set as in [10], and there is a direct line of sight path between the desired base station transmitter and the receiver; for frequency-selective Rayleigh fading (terrestrial interceptor), the delays between the received replicas of the transmitted signal, τ_c , are random integer multiples of the chip duration T_c , there is no direct line of sight path between the base station transmitter and the receiver, and the channel parameters are set according to [11]. The total power transmitted by the base station is normalized to unity, with 20% of the power allocated to the pilot signal, and a fraction of the remainder of the power allocated for communicating with each portable which is in contact with the base station of interest.

Successive interference cancellation schemes are derived in [2, 3], demonstrating significant performance improvements over the conventional receiver which does not employ interference cancellation. We have designed and simulated in software a conventional matched filter receiver (CMF), a conventional multistage successive interference canceling receiver (CSIC) and a modified multistage successive interference cancellation (MSIC) scheme which employ coherent detection and pilot signals to obtain channel estimates. The SIC receivers are shown in Figs. 1 and 2. The conventional K -user demodulator commonly employed in practice is implemented as a bank of optimum detectors for single-user communications. There is one matched filter or RAKE receiver for each leg of the quadrature demodulator for each user, followed by one Viterbi decoder for the convolutional code of each user. The performance of this demodulator is used as one baseline against which we compare the conventional and modified multistage successive interference canceling receivers. For the interference canceling receivers, at each step of each stage of interference cancellation, we weight the re-spread and re-constructed user signal by a partial-cancellation factor. We employ this weighting procedure in order to reduce the effects of imperfect signal reconstruction and cancellation. This way, more reliable estimates (i.e., those corresponding to users which were received with higher powers) receive higher weight in the multiple access interference reconstruction and subsequent cancellation operations. We determined the proper weights by an optimization procedure.

In IS-95, a block of reference symbols (the pilot sequence) is added in parallel to the data stream before transmission over the channel. The received signal is down-converted to baseband (in this paper, we assume ideal carrier frequency and phase acquisition and tracking) and correlated with a locally generated replica of the known reference symbols to obtain unbiased but noisy preliminary channel estimates. The real and imaginary correlation values (obtained from the I- and Q- channels, respectively) are evalu-

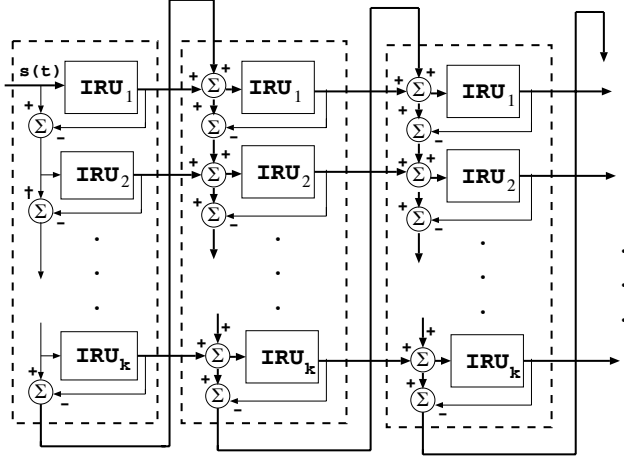

Figure 1: Multistage successive interference cancellation. The block IRU_k stands for interference regeneration unit for user $k = 1, 2, \dots, K$ at each step of each stage. The received signal at base-band is denoted by $s(t)$.

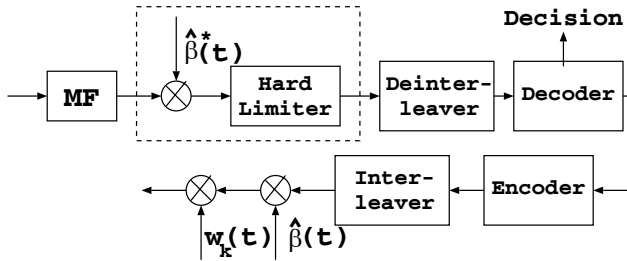

Figure 2: Details of each interference regeneration unit (IRU) for the modified successive interference canceler (MSIC). The dashed block is used only with hard decision decoding. MF, encoder and decoder stand for matched filter, error control encoder and Viterbi decoder for the convolutional code, respectively. The quantity $\hat{\beta}(t)$ represents the channel estimate, $\hat{\beta}^*(t)$ its complex conjugate, and $w_k(t)$ the spreading waveform for user k . The block diagram applies to the case of flat fading; for frequency-selective fading, there is one such interference regeneration unit for each finger of the RAKE receiver. The details of each IRU for CSIC are the same as those pictured here, except they do not contain the deinterleaver, decoder, encoder and interleaver (for CSIC, these 4 blocks are present only at the very last stage, and only after all SIC has been completed).

ated at the sampling instants and stored in memory for the entire length of the incoming sequence. The locally generated replica of the known pilot sequence is then shifted by one chip period, and the correlation procedure is repeated. The vector containing the correlation values contains part of the information needed for sequence synchronization: for the case of frequency-selective fading, the index of the maximum value of the correlation vector gives the delay between the strongest incoming ray and the local pilot sequence, and

the delays of the remaining trackable paths are found from successively searching for additional peaks in the correlation vector. The indices of the peaks and their magnitudes and phases are further processed using a subspace-based iterative algorithm to compensate for the delays, amplitude scalings, and phase rotations introduced by the channel, for every tracked path. The channel estimation algorithm is based upon the iterative method described in detail in [12].

In decoding the binary convolutional code employed on the downlink, we have implemented a modified branch metric for use in the Viterbi algorithm: we use the estimates of the channel gain to compute the metric by evaluating the squared Euclidean distance between the samples at the outputs of the matched filters and the candidate symbols after weighting the latter by the channel gains. This enables us to provide information on channel reliability to the soft-decision Viterbi algorithm employed at the decoder. The essence of modifying the branch metrics is the relative accentuation of more credible information and the relative suppression of less credible information. Our numerical results demonstrate that the modified branch metric leads to improvements in BER performance compared to the case of hard decision decoding when channel estimation errors are present, which is the case in practice.

IV. PERFORMANCE IN MULTICELL ENVIRONMENT

In this section, we describe our study of the performance of the conventional matched filter receiver and the conventional and multistage successive interference canceling receivers in a multicell cochannel interference environment. The receivers are interested in the detection of all the signals emanating from a single base station.

We have conducted extensive computer simulations to estimate the performance of the receivers. We have simulated the different powers assigned to different traffic channels (users), modifying the power separations between users at each Monte-Carlo run to account for user mobility. Performance is reported in terms of average bit error rate (BER) as a function of the average bit energy to noise power spectral density E_b/N_o (both quantities are averaged over all active users in the cell of interest). The simulation model is composed of 7 hexagonal cells, each with a base station at its center. The base station of interest is located in the center of this cell cluster and is comprised of three contiguous sectors, each sector occupying 120° . Transmissions from the other six base stations interfere with the transmissions from the base station of interest. The interference from base stations outside these six is assumed insignificant.

Figs. 3 – 4 show the average BER performance per user vs. the average bit energy to noise power spectral density E_b/N_o . Results are shown for the conventional matched filter (CMF), conventional successive interference canceling (CSIC) and modified successive interference canceling (MSIC) receivers operating in a single cell, two-path flat

Rician fading environment with intercell and intracell multiuser interference. The CSIC and MSIC receivers employ two stages of cancellation each. For comparison purposes, baseline performance is given for a conventional receiver employing a rate 1/2, constraint length 9 convolutional encoding and decoding when only a single user is active in a single cell with no multicell interference, in flat Rician fading with perfect channel estimation of the fading parameters (amplitude and phase). The performance of this receiver in this signal environment is equivalent to the performance of the theoretically optimal receiver in AWGN with coding [2]. When the number of users $K = 15$, the performance of the MSIC is the closest to the single-user bound ($K = 1$) among all receivers considered in this discussion and is superior to the CSIC and the CMF for $K = 15$. As the number of users increases, the gap in performance between the MSIC receiver and the other two receivers is even more pronounced, since the MSIC lowers the BER floors associated with the competing receivers.

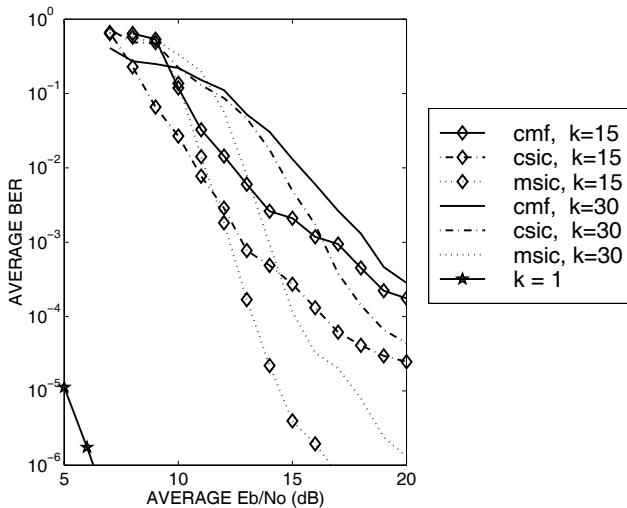

Figure 3: BER Performance of a conventional matched filter receiver, a conventional interference canceling receiver and a modified successive interference canceling receiver operating in a multi cell, frequency-flat Rician fading environment with multiuser interference, with K active users in the cell.

In general, the intercellular to intracellular interference ratio is a random variable, since the interference powers from all surrounding cells are a function of the random numbers of users in adjacent cells, as well as random path loss exponent, shadowing, Doppler spread and voice activity. However, in our simulations we assumed that the path loss exponents for intercell interference in all simulation runs were four and three for the airborne and terrestrial interceptors, respectively. The performance curves are for the case when there are errors in the power control algorithm. The power control error has zero mean and standard deviation of

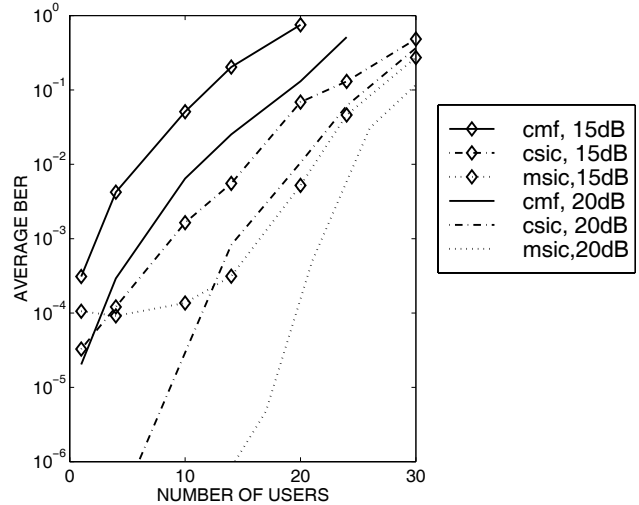

Figure 4: Capacity of a conventional matched filter receiver, a conventional interference canceling receiver and a modified successive interference canceling receiver operating in a multi cell, frequency-flat Rician fading environment with multiuser interference. The legend also indicates the average bit energy to noise power spectral density per user.

1dB. For the range of BERs depicted in our simulation results, the capacity of the system, *from the point of view of the interceptor*, is virtually unchanged compared to the case of perfect power control, assuming the receiver is capable of accurately tracking the time-varying powers of the data channels¹. This is because successive interference cancellation algorithms perform better when the power separations between users are more distinct [2]. This compares favorably with the capacity of the same system employing the conventional matched filter receiver and the conventional interference canceler.

We have also simulated the performance of the two-stage successive interference canceling receivers with imperfect power control, hexagonal cell geometry and path loss exponent of three on a frequency-selective Rayleigh fading channel. The channel model consists of two independent paths. The delays between the paths are assumed to be random integer multiples of the chip period T_c . Both paths are assumed to be tracked by a RAKE receiver utilizing the pilot sequence for channel estimation as described above. All receivers employ one matched filter for each user on each finger of the RAKE receiver; the outputs of the RAKE fingers are combined via equal-gain combining to yield a decision statistic that is used for data symbol estimation. For the successive interference cancellation schemes, there is one multi-stage successive interference canceler for each finger. The

¹However, from the point of view of the mobile users communicating with the base station of interest, the capacity is adversely affected due to errors in the power control algorithm.

assumed path loss exponent for the intercell interference for the terrestrial interceptor is three. All receivers are operating in a multicell scenario with intercell and intracell multiuser interference (with the exception of the baseline receiver ($K = 1$) which does not suffer from multiuser interference.) Due to lack of space, performance curves for the Rayleigh channel will be presented and discussed at the conference.

The capacity of the system in a multicell scenario, like that for a single cell scenario, is slightly smaller with the flat Rician-fading channel than it is with the frequency-selective Rayleigh fading channel when the number of users is not too large. This is because the RAKE receiver employed in the frequency-selective channel provides additional processing gain by combining the outputs of the RAKE fingers dedicated to the signals from the two independently fading paths. However, the capacity in a frequency-flat fading channel is slightly better than that of a frequency-selective channel when the number of users is relatively large or when the signal to noise ratio is small, because then the signal at each RAKE finger suffers from too much interference from the signal that has propagated along the other path. In multicell scenarios, the detectors exhibit BER floors, due to the additional interference and the accumulated errors from imperfect regeneration and cancellation of other users.

V. SUMMARY

The main drawbacks of the interference cancellation techniques discussed in this presentation are suboptimal performance, the need for accurate estimates of received signal amplitudes and chip, bit and frame timings, accurate estimates of carrier phase and frequency and signature codes of all desired users², some power separation between the strongest traffic channel and the next-strongest traffic channel in each successive cancellation stage³, and processing delay. These parameter estimates are not easy to obtain in practice. Most of the required parameters can be estimated from the pilot channel, and the required signature codes can be estimated by using one of the several possible methods proposed in the literature for code waveform estimation, such as [13], for example. The requirements of minimum delay and implementation simplicity necessitate the need to limit the number of cancellations. However, we have shown that with careful receiver design, which exploits the powerful forward error correcting channel codes and takes advantage of the pilot channel and other system parameters, these interference cancellation methods can provide enhanced performance, compared to the performance of the conventional matched filter receiver, and they are near-far resistant. Furthermore, in general they are substantially easier to implement than the optimal receiver: suc-

²For IS-95, the signature codes are known, but for non IS-95 systems, they may have to be estimated.

³In practice, the power separation which is needed is at least 1 dB. In this contribution, we consider power separations of 0.5 to 6 dB.

cessive cancellation requires computational complexity per symbol which is *linear* in the number of users K , in contrast to the optimum demodulator, which has complexity per symbol that is *exponential* in K .

In the near future, we intend to derive analytical performance measures for the performance of the SIC detectors, investigate the robustness of the receivers to parameter estimation errors, and study the application of antenna arrays combined with interference cancellation to the problem of signal interception.

References

- [1] W. A. Gardner, "Signal interception: a unifying theoretical framework for feature detection," *IEEE Trans. Comm.*, vol. 36, (no.8), pp. 897–906, Aug. 1988.
- [2] S. Verdu, "Multiuser detection," *New York: Cambridge University Press*, 1998.
- [3] M. R. Koohrangpour and A. Svensson, "Joint interference cancellation and Viterbi decoding in DS-CDMA," *Proc. IEEE PIMRC*, vol. 3, pp. 1161–5, Sept. 1997.
- [4] Y. Sanada and Q. Wang, "A co-channel interference cancellation technique using orthogonal convolutional codes on multipath Rayleigh fading channels," *IEEE Trans. Veh. Tech.*, vol. 46, No. 1, pp. 114–128, Feb. 1997.
- [5] A. McKellips and S. Verdu, "Multiuser detection for eavesdropping in cellular CDMA," *Proc. Asilomar Conf. on Signals, Systems and Computers*, vol. 2, pp. 1395–9, Nov. 1997.
- [6] A. McKellips and S. Verdu, "Eavesdropping syndicates in cellular communications," *Proc. IEEE VTC*, vol. 1, pp. 318–22, May 1998.
- [7] A. Klein, "Data detection algorithms specially designed for the downlink of CDMA mobile radio systems," *Proc. IEEE VTC*, vol. 1, pp. 203–7, May 1997.
- [8] A. Jalali and P. Mermelstein, "Effects of diversity, power control and bandwidth on the capacity of microcellular CDMA systems," *IEEE Journal on Selec. Areas in Comm.*, vol. 12, pp. 952–961, June 1994.
- [9] P. R. Pawlowski, "Deorthogonalization of ODS-CDMA QPSK by AM/PM nonlinearity," *Wireless Personal Communication (Kluwer Academic Publishers)*, vol. 6, (no. 1-2), pp. 5–25, Jan. 1998.
- [10] R. D. Gaudenzi and F. Giannetti, "DS-CDMA satellite diversity reception for personal satellite communications: satellite to mobile link performance analysis," *IEEE Trans. Veh. Tech.*, vol. 47, No. 2, pp. 658–72, May 1998.
- [11] R. Stuetzle and A. Paulraj, "Modeling of forward link performance in IS-95 CDMA networks," *Proc. IEEE ISSSTA*, vol. 3, pp. 1058–62, Sept. 1996.
- [12] A. J. Weiss and B. Friedlander, "Synchronous DS-CDMA downlink with frequency selective fading," *IEEE Trans. Signal Processing*, vol. 47, no. 1, pp. 158–67, Jan. 1999.
- [13] J. Joutsensalo, "Semi-blind CDMA code estimation in the downlink," *Proc. IEEE VTC*, vol. 2, pp. 1356–60, May 1998.