

# Lawrence Berkeley National Laboratory

## Lawrence Berkeley National Laboratory

### **Title**

DESIGN CONSIDERATIONS and DATA FOR GAS-INSULATED HIGH VOLTAGE STRUCTURES

### **Permalink**

<https://escholarship.org/uc/item/6r4997ws>

### **Author**

Hopkins, D.B.

### **Publication Date**

1975-11-01

Peer reviewed

Presented at 6th Symposium on  
Engineering Problems of Fusion Research,  
San Diego, CA, November 18-21, 1975

LBL-4431

RECEIVED  
LAWRENCE  
BERKELEY LABORATORY

DEC 12 1975

LIBRARY AND  
DOCUMENTS SECTION

DESIGN CONSIDERATIONS AND DATA FOR  
GAS-INSULATED HIGH VOLTAGE STRUCTURES

D. B. Hopkins

November 1975

Prepared for the U.S. Energy Research and  
Development Administration under Contract W-7405-ENG-48

**TWO-WEEK LOAN COPY**

This is a Library Circulating Copy  
which may be borrowed for two weeks.  
For a personal retention copy, call  
Tech. Info. Division, ~~Ext 5545~~

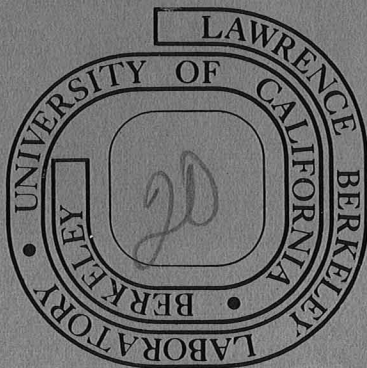

LBL-4431

c.d.

**Lawrence Berkeley Laboratory Library**  
University of California, Berkeley

DESIGN CONSIDERATIONS AND DATA FOR  
GAS-INSULATED HIGH VOLTAGE STRUCTURES\*

D. B. Hopkins  
Lawrence Berkeley Laboratory  
Berkeley, California 94720

Introduction

This paper is intended to benefit the person faced with the occasional task of designing gas insulated high-voltage structures or spark gaps and who must decide upon the proper geometry, spacings, gas type, and pressure for reliable voltage-holding. Generally, the data available to an occasional designer of high-voltage shielding structures is scattered throughout a number of references. The designer is often uncertain as to whether or not the presented data applies to his case, how it will scale if such parameters as materials, dimensions, or pressure are changed, and what factors affect the accuracy of the data. A consistent design approach has been in use by high-voltage specialists for years, but seems to be unfamiliar to many others. This approach is presented below along with a summary of how various factors affect voltage breakdown. The design procedures described apply to situations where the influence of nearby insulators is negligible. The accuracy of the data is estimated to be within 10 to 15%, a value usually attained in practice only when one follows the cautionary advice discussed in the paragraphs on materials preparation, gas properties, and conditioning.

Uniform and Enhanced Fields

If two infinite, plane, conducting electrode surfaces are parallel, are separated by a distance  $X$ , and have a potential difference between them of  $V$ , then everywhere between them there exists a three-dimensionally uniform electric field that can be expressed as

$$E = V/X. \quad (1)$$

(Throughout this paper,  $E$  will have the units of  $\text{kV/cm.}$ ) In this case,  $E$  is the maximum field anywhere in the system. For properly prepared conductors at less than 2 to 3 atm pressure, the maximum field value corresponding to breakdown is only a property of the insulating gas medium and not the type of metal used in the electrodes. For most practical cases, fields are not everywhere uniform and, in fact, are almost always higher at a conductor surface than anywhere in the gaseous insulating medium. For example, in the case of a sphere separated from a plane, the field is higher at the surface of the sphere than elsewhere in the system. The field at the sphere is called an enhanced field and the sphere is referred to as the enhanced electrode. At ordinary pressures, the amount of enhancement is only dependent on the geometry of the electrode system and not on such parameters as pressure or the type of gas. For any generalized system of two electrodes separated by a distance  $X$ , at their point of closest approach, we can define

$$E_{\text{mean}} = V/X \quad (2)$$

and

$$f^* = E_{\text{max}}/E_{\text{mean}}, \quad (3)$$

where  $f^*$  is defined as the field enhancement factor and is equal to the ratio of the maximum field anywhere,  $E_{\text{max}}$ , to  $E_{\text{mean}}$ . Values of  $f^*$  for a number of common geometries are plotted in Figs. 1 through 6. These curves are extremely useful in the design of anti-corona shields.

Figures 1 and 2 are plots of calculated data.<sup>1</sup> The reference to "One Sphere Grounded" refers to the case where one sphere is grounded to one wall of an enclosing conducting box that is spaced several sphere diameters away from the pair of spheres. Figure 3 data was measured in an electrolytic field plotting tank<sup>2</sup> for a cor-  
\*Work done under the auspices of the US ERDA.

ona-shielded thin protrusion between two "infinite" planes. Here  $E_{\text{mean}}$  is defined as the ratio  $V/X$ , as usual. The  $h/X \approx 1$  curve is theoretically derived for small spherical or spheroidal protrusions.<sup>3</sup> Figure 4 presents data measured in an electrolytic tank<sup>4</sup> for determining the required rollup when the outer cylinder terminates. It is for a specific case with  $D/d = 2.72$ , where  $Z_0 = 60 \Omega$ . This configuration offers the maximum voltage-holding ability. Note that in this one instance,  $E_{\text{max}}$  is compared to the field existing at the surface of the inner cylinder. Figure 5 presents data measured in a Teledeltos paper flux-plotting system<sup>5</sup> for edge rollups in planar geometry. Figure 6 presents calculated data<sup>6</sup> for a parallel-wire grid well separated from a plane. Here,  $E_{\text{mean}}$  is the nearly uniform field that exists near the plane.

Avoiding Corona<sup>1</sup>

In most gases at pressures of less than 2 to 3 atm, it has been found that corona is avoided when  $f^*$  can be made smaller than  $\sim 5$ . When this condition is satisfied, breakdown finally occurs, as voltage is slowly raised, without having gone through a period where corona occurs. Also, no significant difference in breakdown voltage is observed as the polarity of the applied voltage is reversed. Breakdown occurs when the basic electric strength of the insulating gas medium is exceeded; this usually takes place first at the surface of the enhanced electrode, imitating the full discharge. At high  $f^*$  values, with applied voltage higher than the corona threshold, strong polarity effects are observed; breakdown voltage is lower with a positive enhanced electrode. Breakdown voltage becomes almost totally dependent on the spacing and very insensitive to the shape of the enhanced electrode. For certain conditions, the breakdown voltage is observed to decrease with increasing pressure. To avoid these effects and the production of ozone (in the case of an air medium) or other deleterious chemical effects, the designer almost always strives to satisfy the criterion  $f^* < 5$ .

Electric Strength of Gases<sup>7-11</sup>

The relative electric strength of the most common insulating gases at atmospheric pressure and in near-uniform fields is as follows:

GAS	AIR	N <sub>2</sub>	CO <sub>2</sub>	H <sub>2</sub>	SF <sub>6</sub>	Freon 12 (CCl <sub>2</sub> F <sub>2</sub> )	Freon 114 (C <sub>2</sub> Cl <sub>2</sub> F <sub>4</sub> )	Freon 116 (C <sub>2</sub> F <sub>6</sub> )
$V/V_{\text{air}}$	1.0	1.1	0.95	0.6	2.5-3.0	2.3-2.5	2.8	1.5
Boiling Point, °C at 1 atm	---	---	---	---	---	-29.8	+3.6	-78.2

The absolute electric strength of a gas in uniform fields as a function of pressure, temperature, and separation is described by Paschen's law, which can be written as follows for air

$$E_{\text{max}} = \frac{V_{\text{max}}}{X} = 24.2 \left( \frac{293}{T} \right) \left( \frac{p}{760} \right) + 6.08 \sqrt{\frac{1}{X} \left( \frac{293}{T} \right) \left( \frac{p}{760} \right)} \quad (4)$$

where  $X \equiv$  separation in cm  
 $p \equiv$  pressure in Torr  
 $T \equiv$  temperature in K

and  $E_{max}$  is the breakdown field [not to be confused with the generalized maximum field referred to in Eq. (2)]. Equation (4) agrees well with experimental results and is plotted in Figs. 7 and 8. Note that the often quoted value of 30 kV/cm for the electric strength of air strictly applies only to a 1 cm separation.

The effect of altitude of  $E_{max}$  for air is governed by the change in air density. A plot of  $E_{max}$  vs altitude is shown in Fig. 9. Paschen's law is observed to fail at pressures  $\gtrsim 120$  psi, for air;  $E_{max}$  then varies  $\sim p^{0.7}$ .  $E_{max}$  is plotted vs pressure for air and sulphur hexafluoride ( $SF_6$ ) in Fig. 10. This figure reveals a common phenomenon at higher pressures; namely, the significant influence the choice of electrode materials has on  $E_{max}$ .<sup>10</sup> It also shows that  $N_2$  becomes progressively poorer than air at higher pressures.

$SF_6$  is completely non-toxic under ordinary conditions but slowly decomposes in the presence of continuous open arcs. The breakdown products have been analyzed<sup>11</sup> and are highly toxic and corrosive. However, one should not decide against its use solely because of these factors. The breakdown products can be completely removed by flowing the gas through activated alumina.<sup>11,12</sup> For most applications involving only infrequent sparking and relatively small quantities of the gas, simple venting outside a building is a common practice.  $SF_6$  is very commonly used in pressurized spark gaps for switching high-energy systems.<sup>13</sup> It has been found very important to dry the  $SF_6$  and avoid any trace of oils in order to obtain predictable, repeatable results in spark gap applications.

Figure 11 shows  $E_{max}$  vs percent fill for mixtures of  $SF_6$  in  $N_2$  and Freon 12 in air.<sup>14</sup> Both are in common usage. The approximately 2.3:1 superiority of Freon 12 over air has been found to hold at least up to its liquification point ( $\sim 75$  psig at  $23^\circ C$ ). It is cheaper than  $SF_6$  but has the disadvantage of forming conductive carbon deposits in the presence of arcing. It is therefore only suitable when there is infrequent sparking, and not at all for spark gaps. The rapid improvement in  $E_{max}$  with a small addition of  $SF_6$  to  $N_2$  is striking. Except where recovery of gas is planned, there is rarely justification for increasing the  $SF_6$  percentage beyond 25 or 30%. Pressurized  $CO_2$  and  $N_2-CO_2$  mixtures display 20-25% lower values of  $E_{max}$  than does air at the same pressure for pressures of 100 to 300 psig. At high pressures, the overall area of the electrodes strongly affects  $E_{max}$ . Figure 12 shows this dependence for  $N_2$  and  $N_2-CO_2$  mixtures.

It is important to realize that even at voltages as low as a few kilovolts, sharp edges and/or closely spaced projections can produce large field enhancements, causing  $E_{max}$  to be exceeded and leading to breakdown.

#### Miscellaneous Effects

For sinusoidal cw applied voltage, breakdown voltage steadily decreases with frequency. The reduction levels off at  $\sim 18$  to 20% at 61 kHz and remains essentially unchanged throughout the rf and microwave regions. For ac, the peak value of the voltage waveform is the correct one to use for shielding design purposes.

For pulsed voltage application times less than a few microseconds,<sup>15-17</sup> time-dependent processes result in values of  $E_{max}$  that increase as the pulse width is decreased. In air, for a constant separation at atmospheric pressure, the permissible uniform field value of  $E_{max}$  increases a factor of  $\sim 3$  as pulse width is reduced from 1  $\mu$ sec to 1 nsec (where statistical breakdown lags are eliminated by ensuring that free electrons are readily available). Plots of  $E_{max}/P$  vs  $pr$  for short-pulse dc and microwave frequencies between 1 and 27 GHz, for numerous gases, are given in references 15 and 16. Here,  $\tau$  is the maximum allowable pulse width and equals

the formative time of the arc breakdown. Design relations have been developed<sup>17,18</sup> which permit precision design of spark gaps operated in the nanosecond regime with non-sinusoidal waveforms, and which have repeatable, predictable breakdown times, even with high  $f^*$  values.

Breakdown voltage increases with humidity<sup>1,7,10,19</sup> by an amount that is relatively independent of electrode shapes. However, it is strongly dependent on the type and geometry of insulators present and on polarity at high values of field enhancement. Generally, one can expect variations in breakdown voltage to be  $\lesssim 10$  to 15% over normal ranges of relative humidity. The presence of water condensation on electrode surfaces can reduce breakdown voltages by 30 to 50%, compared to that of dry surfaces. Oil has a slightly smaller effect. If present on insulator surfaces, water can cause large reductions in breakdown voltage.

Whenever possible, new systems should be conditioned by allowing sparking to occur at a low energy value (typically in the  $10^{-3}$  to  $10^{-1}$  joule range). New spark gaps typically require  $\sim 50$  to 500 shots to become conditioned up to a reliable, repeatable breakdown voltage level. It frequently is more difficult to fully condition anti-corona shields but the same principles apply. To shorten the conditioning process, or to increase the likelihood of a shield design performing as it theoretically should, electrode surfaces should be smooth, polished, and clean. For the rare occasions when it is necessary to have electrodes with  $f^* = 1$  (no field enhancement), Rowgowski-profile electrodes can be used.<sup>20</sup> This design achieves the  $f^* = 1$  condition with the minimum electrode extent. Cleanliness is essential to good performance. All fingerprints, oils, dust and other contaminants should be removed. Alcohol or Freon-type solvents are commonly used for this purpose. When the application is a pressurized spark gap, the conditioning should be performed at a pressure near the maximum value anticipated. A curve of breakdown voltage vs pressure is usually plotted, averaging many readings for each point, and is very useful in establishing changing operating points.

Such gases as helium and hydrogen at temperatures near their liquification points ( $4.2^\circ K$  and  $20^\circ K$ , respectively) have higher values of  $E_{max}$  than air at room temperatures. Data for several gases at small and large separations are given in references (21) and (22).

#### Design Philosophy and Procedure

At the outset of a design, a decision should be made as to what safety factor is desired between the maximum operating level and the breakdown level. This is defined as:

$$\alpha = \frac{V_{\text{operate, max}}}{V_{\text{breakdown}}} = \frac{V_{\text{op}}}{V_{\text{BD}}} \quad (\alpha \leq 1) \quad (6)$$

For indoor research apparatus,  $\alpha$  is typically in the 0.3 to 0.8 range, depending on the required reliability, shielding costs, and how undesirable are the consequences of an occasional breakdown. Well designed spark gaps switching large, short-pulsed systems have a very low prefire probability and low jitter in breakdown voltage when  $\alpha$  is  $\approx 0.85$ . Most spark gaps operated at  $\alpha \leq 0.7$  to 0.75 display acceptable spurious breakdown rates when operated under dc or cw conditions.

Next, the designer should recognize that nearly all shielding requirements encountered can be well approximated by and designed according to the geometries of figures 1 to 6 and the subsequent data presented above.

The third point to be made is that the final design should be tested (and conditioned) if at all possible to

verify the design. At voltages > 100 kV, being overly cautious in choosing  $\alpha$  can result in large shields that are more expensive than necessary. Also the cost of hipot power supplies may be excessive.

Finally, we recall that the maximum field anywhere (normally at an enhanced electrode) cannot exceed the value of  $E_{max}$  for the gas medium under the conditions employed. Setting this value of  $E_{max}$  equal to the first equality in (4), and combining with (6) yields

$$f^* = \frac{\alpha X E_{max}}{V_{op}} \quad (7)$$

where  $E_{max}$  is the near-uniform field value obtainable from Figs. 6 through 12. Usually there is only one unknown in (7) so that most practical problems may be solved. Examples of common problems include solving for the required shield diameter, given the quantities on the right hand of (7), or solving for the required pressure in a specific gas, given a fixed geometry, operating voltage, and  $\alpha$ -value.

For often-encountered geometries and gases, the foregoing procedures can be used to plot more specialized but easily referenced data. An example of this is the useful plot of Fig. 13 (in this case based on an empirical relation which fits experimental data).<sup>23</sup>

#### Acknowledgements

The author thanks H. Aslin for permission to use the experimental results obtained at Physics International Co., R. S. Christie for permission to use Fig. 13, and S. W. Schwenterly (HNL) for supplying the cryogenic data references.

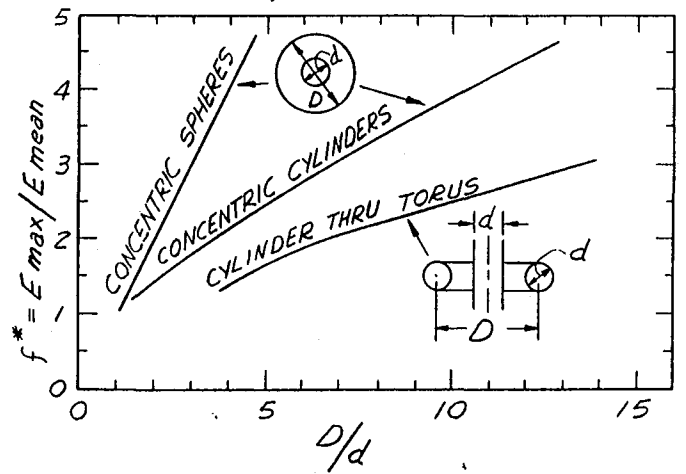

Figure 2

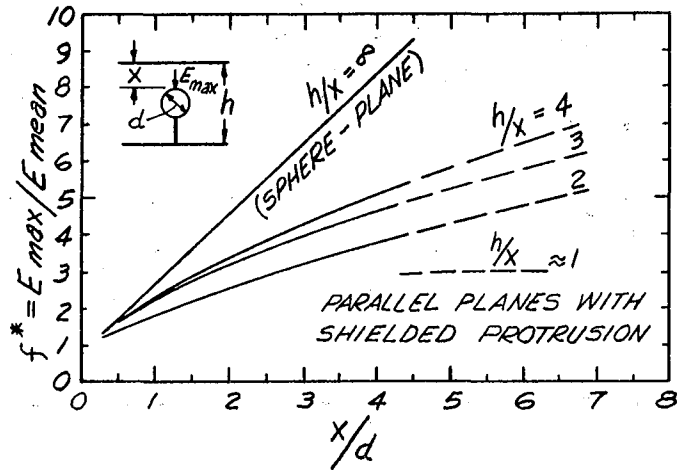

Figure 3

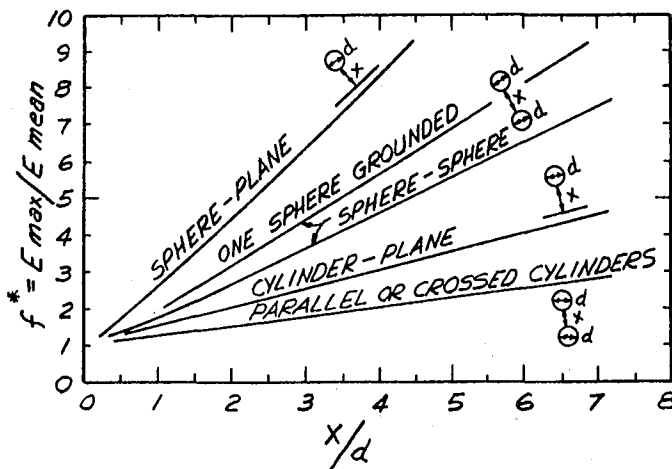

Figure 1

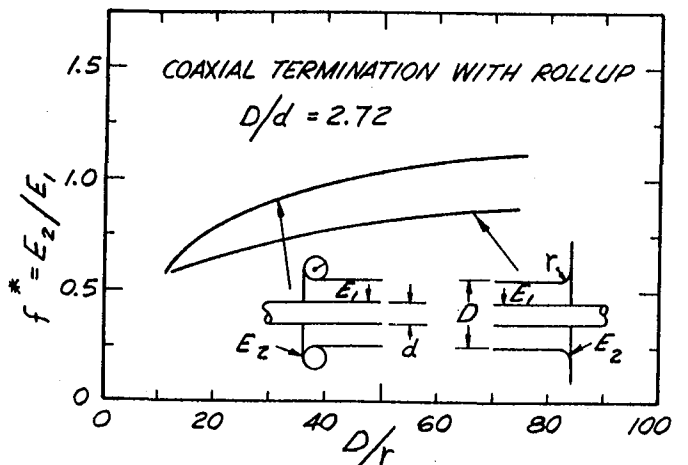

Figure 4

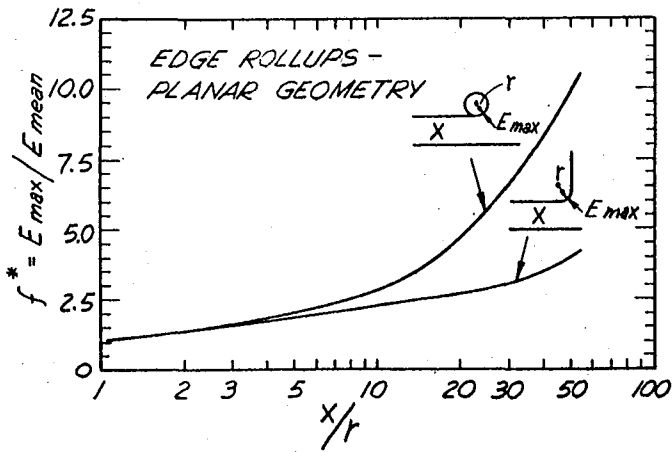

Figure 5

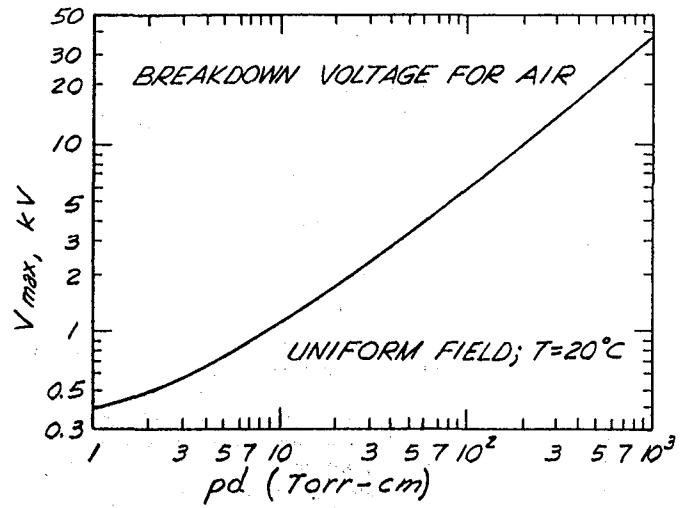

Figure 8

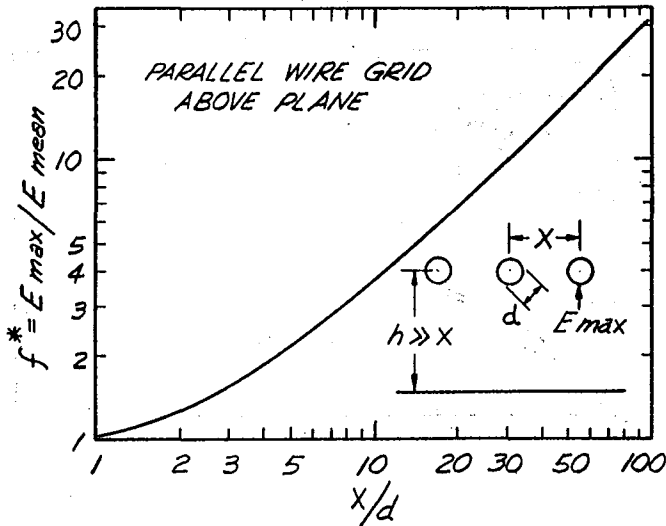

Figure 6

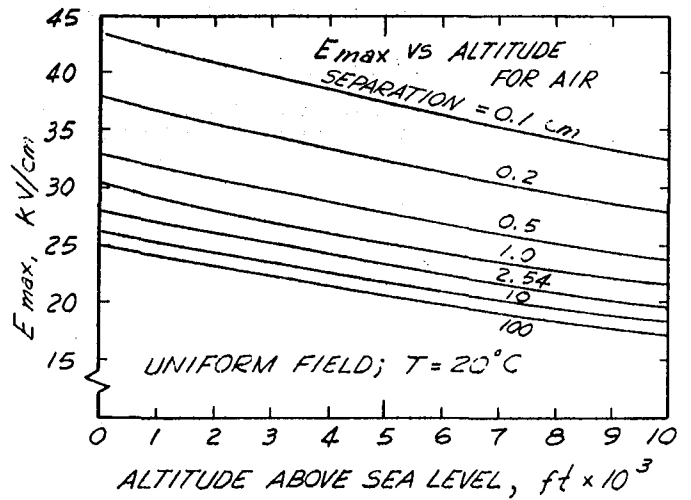

Figure 9

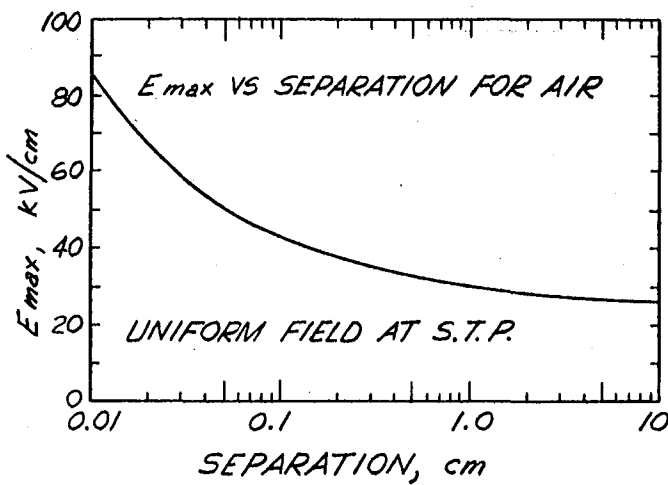

Figure 7

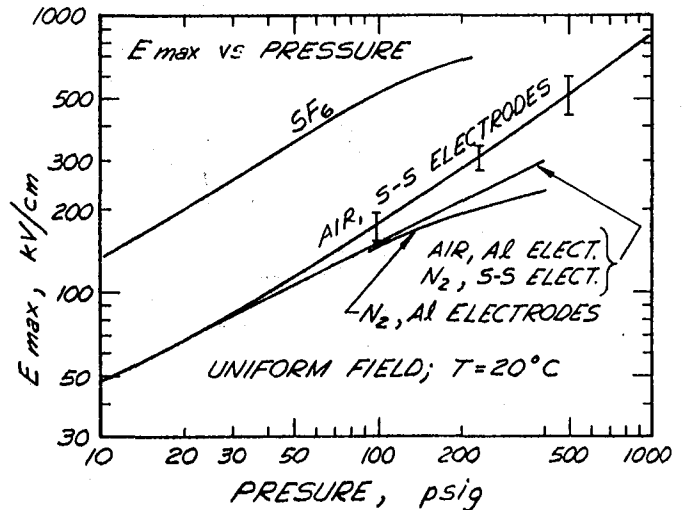

Figure 10

References

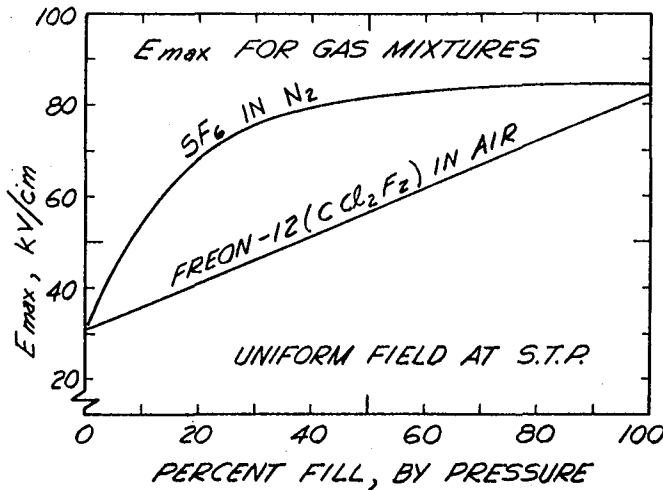

Figure 11

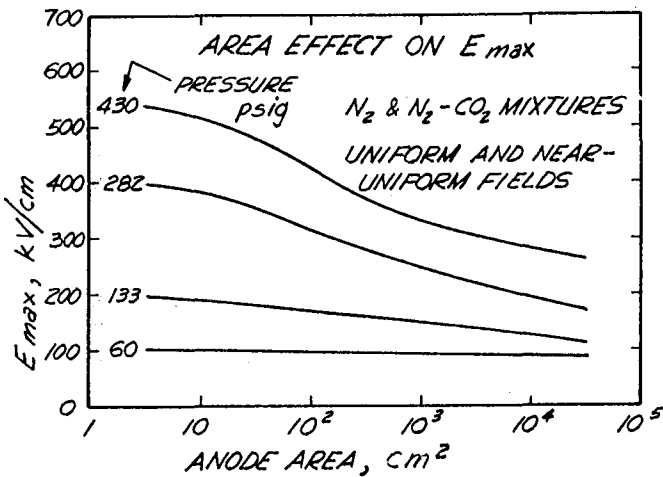

Figure 12

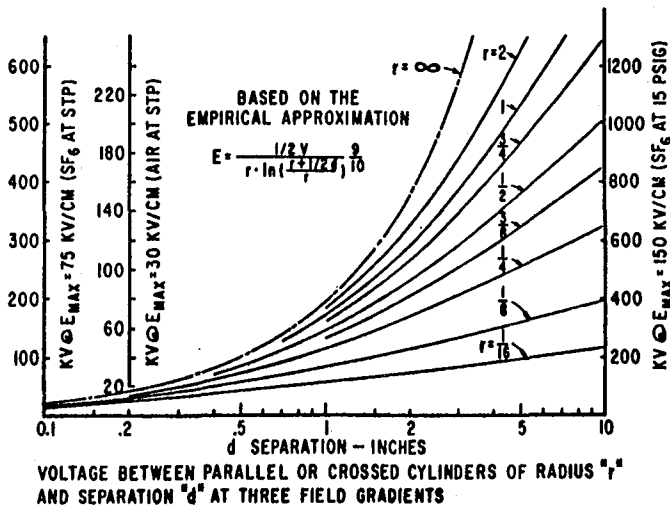

Figure 13

1. L. L. Alston, High Voltage Technology (Oxford University Press, London, 1968).
2. H. Aslin, et al., Design Construction and Testing of the Siegf II Electromagnetic-Pulse Generator, Physics International Co. Report PIFR-180, 1972.
3. P. Moon and D. E. Spencer, Field Theory for Engineers (D. Van Nostrand, Princeton, N. J., 1961).
4. H. Aslin, Additional Notes on the Oil-Freon-12 Interface Testing, Siegf II Note No. 12, Physics International Co., 1969
5. Measured by L. Morris and H. Aslin, Physics International Co., 1969.
6. P. Hersey, Parallel Plate Wire Grid Enhancement, Siegf II Note No. 6, Physics International Co., 1969.
7. J. D. Cobine, Gaseous Conductors (Dover, New York, 1958).
8. M. J. Mulcahy, et al., A Review of Insulation Breakdown and Switching in Gas Insulation (Insulation Circuits, August 1970).
9. A. E. Javitz, Design Advantages of Gas Dielectrics (Electronics Design, Aug. 1965).
10. J. M. Meek and J. D. Craggs, Electrical Breakdown of Gases (Oxford Clarendon Press, London, 1953).
11. P. G. Ashbaugh, et al., Sulphur Hexafluoride--Its Properties and Use as a Gaseous Insulator in Van De Graaff Accelerators, IEEE Trans. Nucl. Sci. NS-12, 3, June 1965.
12. Sulphur Hexafluoride for Gaseous Insulation, Baker and Adamson Co., TB-85603.
13. Design Review III; Design Development of the Aurora Facility, Physics International Co. Report PISR-127-4, 1969.
14. T. Tilton, Voltage Breakdown of Freon-12/Air Mixtures, Siegf II Experimental Report No. 23, Physics International Co., 1969.
15. P. Felsenthal and J. M. Proud, Nanosecond-Pulse Breakdown in Gases, Phys. Rev. 139A, 1796 (1965).
16. P. Felsenthal, Nanosecond-Pulse Microwave Breakdown in Air, J. Appl. Phys. 37, 12 (1966).
17. J. C. Martin, UKAWRE, Aldermaston, England--numerous papers on the subject; e.g., Duration of the Resistive Phase and Inductance of Spark Channels, Report SSWA/JCM/1065/25, 1965.
18. H. Aslin, et al., Design of an Advanced Siegf II Pulse Generator, Phase II, Physics International Co. Report AFWL-TR-69-79, Aug. 1969.
19. F. W. Peek, Jr., Dielectric Phenomena in High Voltage Engineering (McGraw-Hill, New York, 1929).
20. J. D. Cobine, Gaseous Conductors (Dover, New York, 1958), p. 177.
21. J. Thoris, et al., Cryogenics, p. 147, April 1970.
22. B. Fallou, Cryogenics, p. 142, April 1970.
23. V. S. Foote and R. S. Christie, Mechanical Design of a 70 kV Pulsed Floating Deck Switch, Proc. 5th Symp. on Engineering Problems of Fusion Research, Princeton Univ., November 1973 (IEEE Pub. No. 73CH0843-3-NPS), p. 489.





**LEGAL NOTICE**

*This report was prepared as an account of work sponsored by the United States Government. Neither the United States nor the United States Energy Research and Development Administration, nor any of their employees, nor any of their contractors, subcontractors, or their employees, makes any warranty, express or implied, or assumes any legal liability or responsibility for the accuracy, completeness or usefulness of any information, apparatus, product or process disclosed, or represents that its use would not infringe privately owned rights.*

TECHNICAL INFORMATION DIVISION  
LAWRENCE BERKELEY LABORATORY  
UNIVERSITY OF CALIFORNIA  
BERKELEY, CALIFORNIA 94720