

# Lawrence Berkeley National Laboratory

## Recent Work

### Title

CURRENT-CONTROLLED PHASE RETARDATION PLATE

### Permalink

<https://escholarship.org/uc/item/6ps8h44b>

### Authors

Zak, B.D.  
Chang, B.  
Hadeishi, T.

### Publication Date

1974

CURRENT-CONTROLLED PHASE RETARDATION PLATE

B. D. Zak, B. Chang and T. Hadeishi

January 1974

Prepared for the U. S. Atomic Energy Commission  
under Contract W-7405-ENG-48

**For Reference**  
Not to be taken from this room

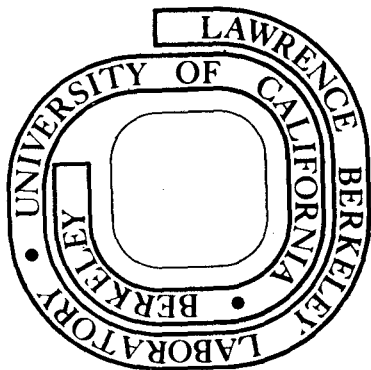

## **DISCLAIMER**

This document was prepared as an account of work sponsored by the United States Government. While this document is believed to contain correct information, neither the United States Government nor any agency thereof, nor the Regents of the University of California, nor any of their employees, makes any warranty, express or implied, or assumes any legal responsibility for the accuracy, completeness, or usefulness of any information, apparatus, product, or process disclosed, or represents that its use would not infringe privately owned rights. Reference herein to any specific commercial product, process, or service by its trade name, trademark, manufacturer, or otherwise, does not necessarily constitute or imply its endorsement, recommendation, or favoring by the United States Government or any agency thereof, or the Regents of the University of California. The views and opinions of authors expressed herein do not necessarily state or reflect those of the United States Government or any agency thereof or the Regents of the University of California.

## CURRENT-CONTROLLED PHASE RETARDATION PLATE\*

B. D. Zak, B. Chang,<sup>†</sup> and T. HadeishiDepartment of Physics  
University of California  
Berkeley, CA 94720

and

Energy and Environment Division  
Lawrence Berkeley Laboratory  
University of California  
Berkeley, CA 94720

January 1974

## ABSTRACT

A plate of fused quartz mounted in the jaws of a magnetic clamp serves as a current-controlled phase retardation plate. The current to the clamp controls the stress on the quartz plate, and hence the amount of stress-induced birefringence. The device described here can be used in a D.C. mode as a fixed phase retardation plate, or in an A.C. mode as a polarization modulator at frequencies up to several hundred Hertz. This device offers several advantages over other polarization modulators available.

## I. Introduction

In experiments involving linearly or circularly polarized light, modulating devices which alternately transmit light of differing polarization are frequently used in conjunction with phase-sensitive detection to enhance the signal-to-noise ratio;<sup>1</sup> such devices include modulators of the Kerr or Pockels cell variety,<sup>2</sup> rotating polarizers,<sup>3, 4</sup> and fused quartz stressed by piezoelectric crystals.<sup>5-7</sup>

Each of these devices have serious limitations; Kerr cells have low transmission, and the materials used in Pockels cells strongly absorb in the ultraviolet. Rotating modulators work well at low frequencies, but frequencies more suitable for phase sensitive detection are not easily attained.<sup>8</sup> The piezoelectrically-stressed fused quartz modulators must be operated at a resonant frequency of the quartz plate because of limitations imposed by the driving crystals; these fixed frequencies (several kHz) are not convenient for all applications of phase-sensitive detection. Here we report a current-controlled phase retardation plate which uses a magnetic clamp to produce stress birefringence.

## II. Theory

Cubic crystals and amorphous solids become

birefringent if subjected to mechanical stress. This effect, first noted by Brewster,<sup>9, 10</sup> can be explained by considering the index of refraction parallel and perpendicular to the stress.

A stress deformed body may be described by the strain tensor:

$$u_{ik} = \frac{1}{2} \frac{\partial u_i}{\partial x_k} + \frac{\partial u_k}{\partial x_i}$$

where  $\vec{u}(x,y,z)$  is the displacement vector for points inside the material. When the displacements are small, only first order terms are needed in the dielectric permeability tensor:<sup>11</sup>

$$\epsilon_{ik} = \epsilon_0 \delta_{ik} + a_1(\omega) u_{ik} + a_2(\omega) u_{\ell\ell} \delta_{ik}$$

Here  $\epsilon_0$  is the dielectric permeability constant of the isotropic material in the absence of stress,  $\delta_{ik}$  is the Kronecker delta (equal to one if  $i = k$ , otherwise zero), and  $a_1(\omega)$ ,  $a_2(\omega)$  are wavelength-dependent strain-optical coefficients; the repeated indices imply summation. If we consider the material stressed in the  $x$  or  $y$  directions, with light incident along the  $z$  axis, the two relevant components of  $\epsilon$  are:

$$\epsilon_{xx} = \epsilon_0 + a_1 u_{xx} + a_2(u_{xx} + u_{yy} + u_{zz})$$

$$\epsilon_{yy} = \epsilon_0 + a_1 u_{yy} + a_2(u_{xx} + u_{yy} + u_{zz})$$

Since  $\epsilon_{xx}$  and  $\epsilon_{zz}$  differ little from  $\epsilon_0$ , and since here  $n = \sqrt{\epsilon}$ , we find:

$$\frac{1}{\epsilon_{xx}} - \frac{1}{\epsilon_{yy}} = \frac{1}{n_x^2} - \frac{1}{n_y^2} = \frac{a_1(\omega)}{\epsilon_0} [u_{yy} - u_{xx}]$$

Further expansion, neglecting higher order terms, yields:

$$n_x = n_y \left[ 1 - \frac{1}{2} n_x^2 \frac{a_1(\omega)}{\epsilon_0} (u_{yy} - u_{xx}) \right].$$

Taking  $n_0 = \sqrt{\epsilon_0}$ , and using the fact that  $n_0$  differs little from  $n_x, n_y$ :

$$n_x - n_y = - \frac{1}{2n_0} a_1(\omega) (u_{yy} - u_{xx})$$

Consequently, the retardation (in radians) between x and y polarized components of wavelength  $\lambda$ , after traversing a length  $\ell$  of birefringent material is given by:

$$\delta = \frac{2\pi}{\lambda} (n_y - n_x) = \frac{\pi\ell}{n_0\lambda} a_1(\omega) (u_{yy} - u_{xx})$$

Since strain is proportional to stress in linear materials, this formula is often written as:<sup>12</sup>

$$\Gamma = \frac{CT\ell}{\lambda}$$

where  $\Gamma = \frac{\delta}{2\pi}$  is the retardation in wavelengths, T is the applied tensile stress in Newtons/meter,<sup>2</sup>  $l$  is the length of the light path in the material,  $\lambda$  is the wavelength, and C is the stress-optical constant in Brewsters ( $10^{-12} \text{ m}^2/\text{N}$ ).

### III. Construction

We have used several different versions of the current-controlled phase retardation plate. A diagram of the most recent version is shown in Fig. 1. The fused quartz plate (.5 x 1 x 7.5 cm) is held in the grip of a magnetic clamp made from a split-C laminated pulse-transformer core. A rigid connection is maintained between the poles on one side of the clamp. On the other side, a .5 mm gap is obtained by properly choosing the length of the quartz plate. The clamp is actuated by a pair of drive coils wound on the transformer coil. The device is mounted so that the quartz plate makes an angle of 45° with respect to the polarization of the incoming light.

Various means can be employed to hold the quartz in place; here we have just epoxied the ends of the plate to the transformer coil.

To obtain a uniform stress distribution, and hence uniform retardation over the active area, it is necessary to take some care in mounting the plate. Before making the



mounting permanent, one must check the stress distribution by viewing the plate between crossed polarizers with a D.C. current applied to the clamp. The mounting of the quartz is adjusted to give the most uniform stress. We have found that slightly rounding the ends of the quartz plate makes it easier to obtain the desired uniformity over the central region.

In our application, we wish to cycle the device from zero to half wave retardation at about 80 Hz. An oscillator, solid state audio amplifier, and D.C. bias supply provide the necessary drive currents. The retardation plate, along with its drive circuitry may be mounted in a 3-width NIM module.

#### IV. Results

To measure the performance of the device, we allow light which is linearly polarized at  $45^\circ$  with respect to the stress axis to fall upon the retardation plate. The expected polarization of the light emerging from the plate is shown as a function of applied stress in Fig. 2. With no stress, the polarization is unaltered. Increasing stress generates first elliptically, then circularly, and finally, with half-wave retardation, linearly polarized light emerging from the plate; light is polarized perpendicular to the incident light. Further increase of stress retraces the pattern in reverse order, until at full wave retardation, the emerging light is again

polarized parallel to the incident light.

If one places the retardation plate between properly aligned crossed polarizers, one expects zero transmission at zero current; as the current is increased, the transmission should increase until the retardation is half-wave, and then should fall with further increase in current. The result of measurements taken with this configuration, using Glan-Thomson prisms as polarizers, is shown in Fig. 3. Here the transmitted intensity is plotted relative to that obtained with parallel polarizers.

When an A.C. current is superimposed on a properly chosen bias current with the experimental arrangement described above, the transmitted intensity cycles between zero and maximum as the retardation plate modulates the polarization of the incident light. In Fig. 4 we show the output of a photomultiplier monitoring the transmitted light at 2614 Å from a lead discharge lamp. The photo is a triple exposure; the top and bottom traces give the intensity with parallel and crossed polarizers respectively.

## V. Conclusion

Devices based upon stress induced birefringence produced by a magnetic clamp overcome several of the disadvantages cited earlier for other types of polarization

modulators. They are inexpensive, can be designed to transmit well into the UV, have large usable area and high angular acceptance, and are easily used at frequencies convenient for phase-sensitive detection. Unlike the piezo-electric devices, they can also be used in a static mode as variable phase retardation plates. In addition, a given device can be employed over a broad range of wavelengths by simply adjusting the drive currents. The same device can be used to switch between linearly polarized components, or circularly polarized components, again, with only an electrical adjustment.

The current-controlled phase retardation plate was developed for use in the Isotope-Zeeman Atomic Absorption Spectrometer, an instrument which uses polarization modulation to effect automatic background correction in atomic absorption trace-element measurements.<sup>8</sup> We wish to thank David Church, Douglas MacDonald and Mich Nakamura for their contributions to the development of the device described here.

REFERENCES

- \* Work supported by the U.S. Atomic Energy Commission, and by NSF-RANN Grant AG 396.
- † Permanent address: California State University, Los Angeles, California 90032.
- 1 T. Hadeishi, Appl. Phys. Lett. 21, 438 (1972).
- 2 J. P. Kaminow and E. H. Turner, Appl. Optics 5, 1612 (1966).
- 3 A. Omont, Comptes Rend. 260, 3331 (1965).
- 4 P. Boros, R. Schwartz, and P. Cahill, Rev. Sci. Ins. 41, 44 (1970).
- 5 L. F. Mollenauer, D. Downie, H. Engstrom, and W. B. Grant, Appl. Optics 8, 661 (1969).
- 6 G. Baldacchini and L. F. Mollenauer, Appl. Optics 11, 2676 (1972).
- 7 I. Z. Steinberg and A. Gafni, Rev. Sci. Ins. 43, 409 (1972).
- 8 T. Hadeishi, D. A. Church, R. D. McLaughlin, B. D. Zak, and M. Nakamura, Lawrence Berkeley Laboratory Report LBL 1593.
- 9 M. Born and E. Wolf, Principles of Optics (Pergamon, New York, 1970).
- 10 H. Mueller, J. Amer. Ceramic Soc., 21, 27 (1938).
- 11 L. D. Landau and E. M. Lifshitz, Electrodynamics of Continuous Media (Addison-Wesley, New York, 1960).
- 12 American Institute of Physics Handbook (McGraw-Hill, New York, 1972) pp. 6-232, 233.

FIGURE CAPTIONS

Figure 1. Diagram of current controlled phase retardation plate. (a) Plate of fused quartz. (b) Laminated pulse transformer core (Arnold Engineering AL 98 or Westinghouse L98). (c) .5 mm gap. (d) Drive coils (about 200 turns each). (e) Stiffener plates epoxied to the transformer core.

Figure 2. Expected polarization of light emerging from the phase retardation plate as the applied stress is increased.

Figure 3. Relative transmission through crossed polarizers with a current-controlled phase retardation plate mounted in between.

Figure 4. Modulation of light transmitted through crossed polarizers with appropriately chosen A.C. and D.C. currents applied to the magnetic clamp.

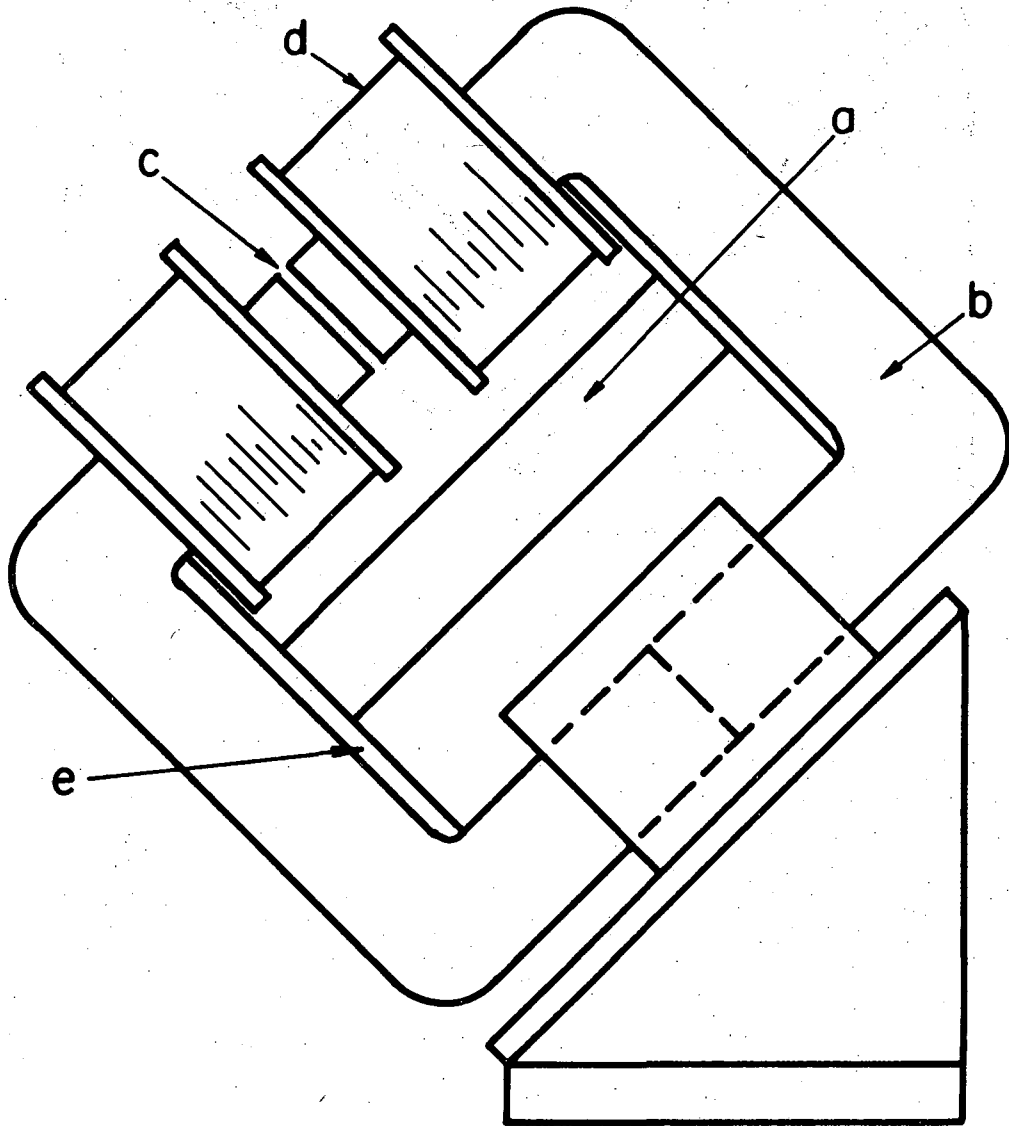

XBL 748 - 3969

Fig. 1.

Incident Light  
Vertically Polarized

Incident Light  
Horizontally Polarized

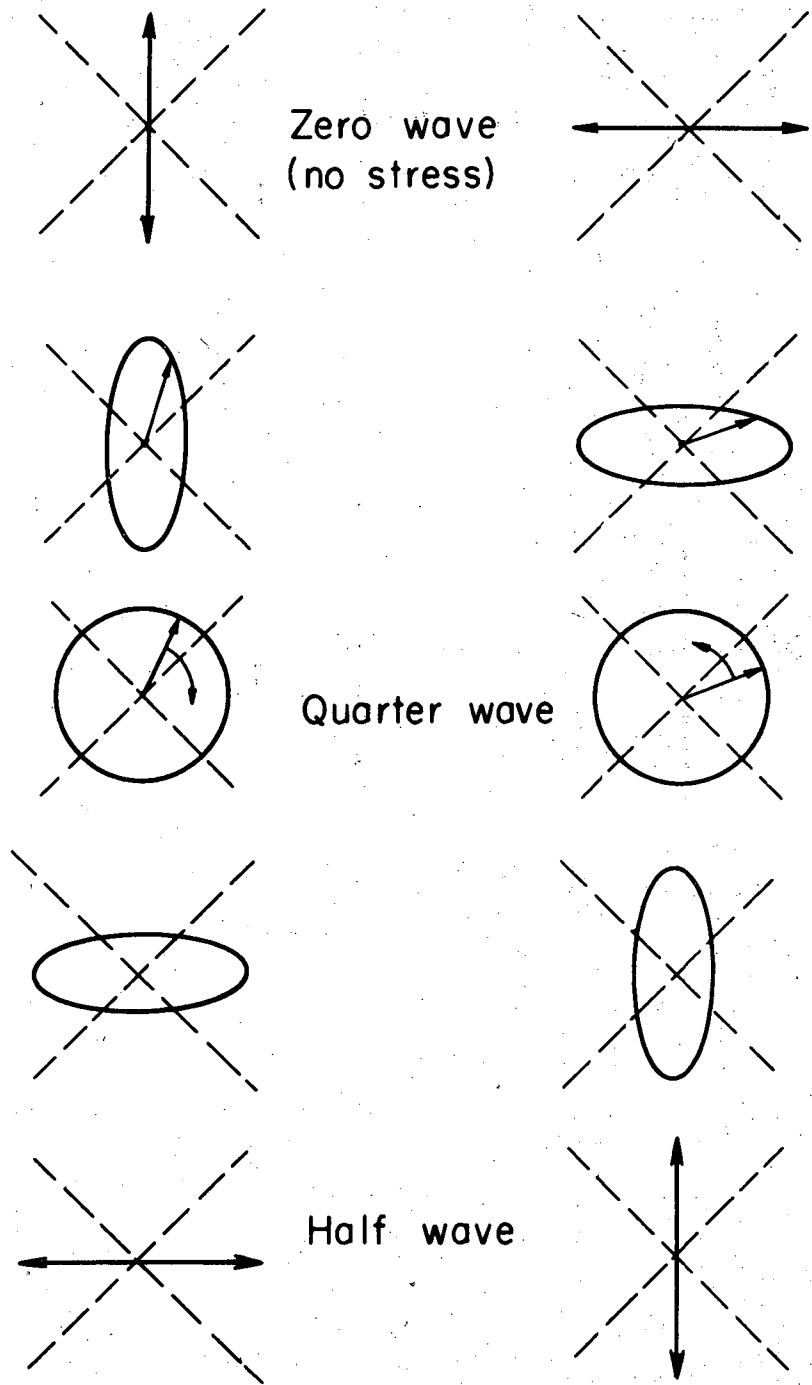

XBL737-3288

Fig. 2.

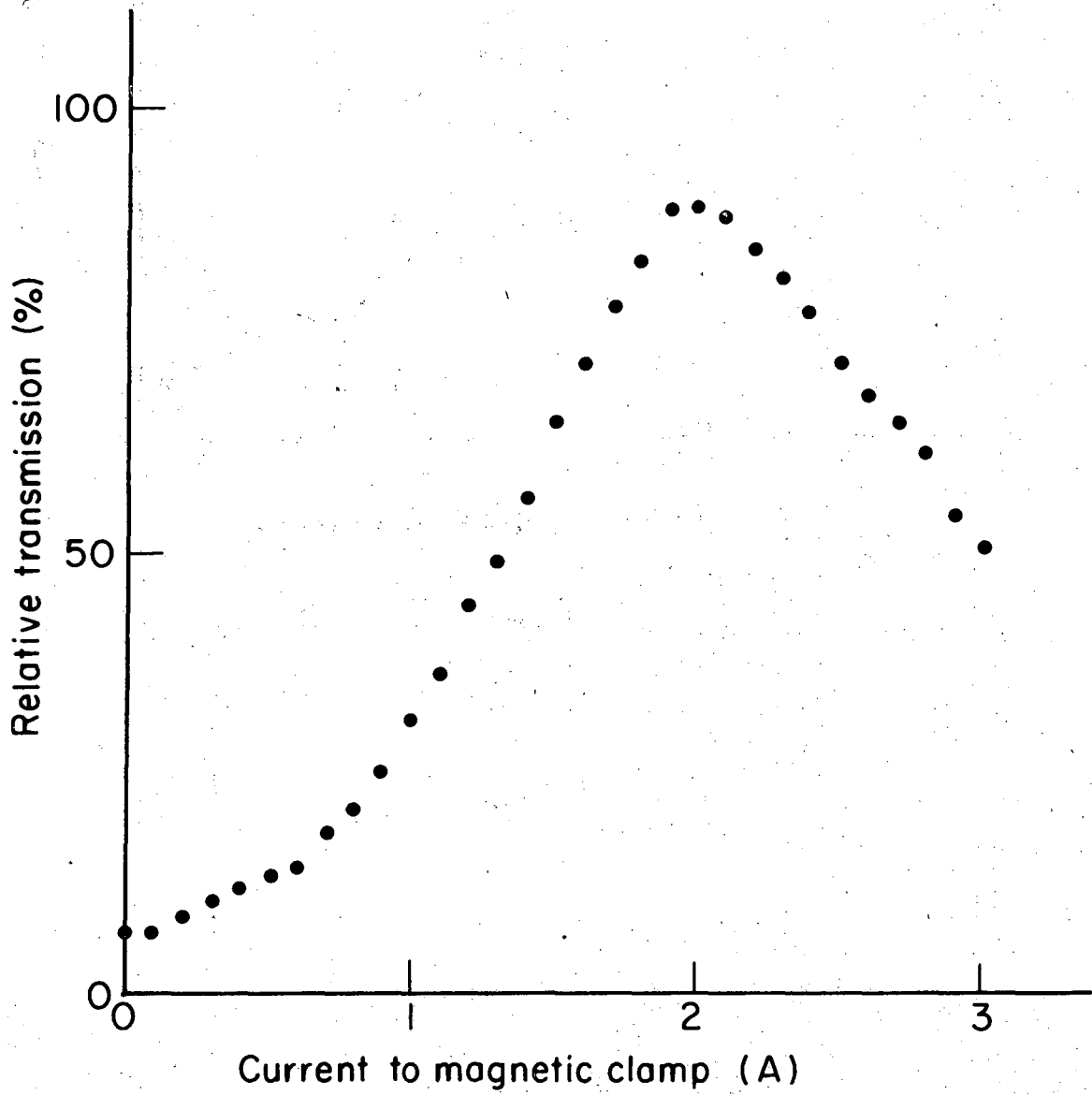

XBL 748-3970

Fig. 3.



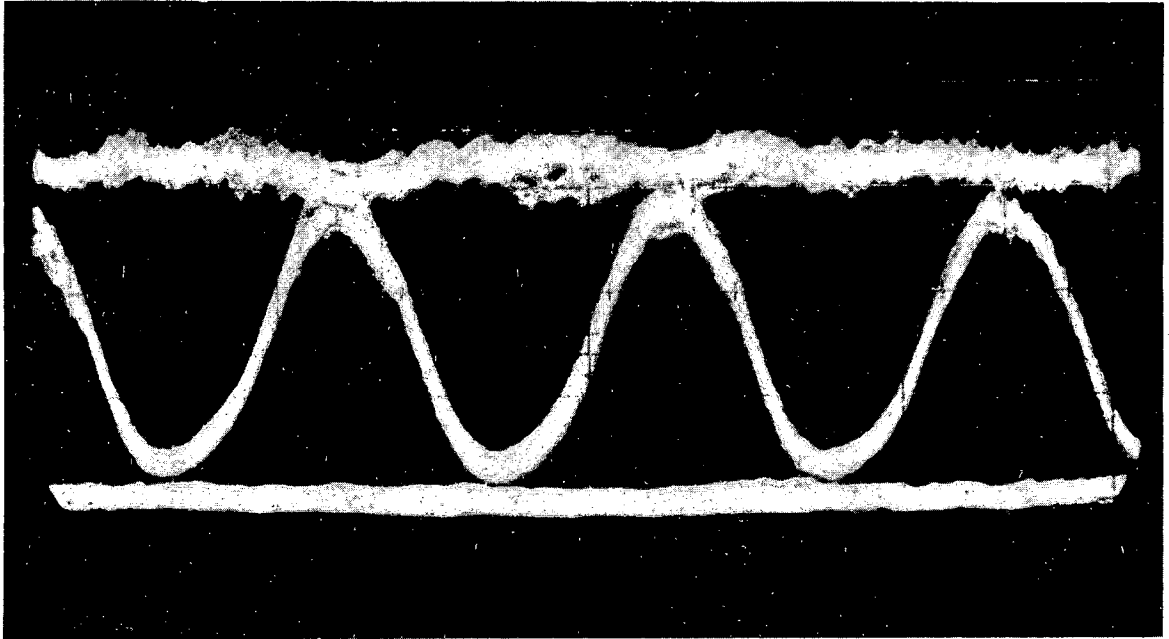

XBB 748-5496

Fig. 4.

## LEGAL NOTICE

*This report was prepared as an account of work sponsored by the United States Government. Neither the United States nor the United States Atomic Energy Commission, nor any of their employees, nor any of their contractors, subcontractors, or their employees, makes any warranty, express or implied, or assumes any legal liability or responsibility for the accuracy, completeness or usefulness of any information, apparatus, product or process disclosed, or represents that its use would not infringe privately owned rights.*

TECHNICAL INFORMATION DIVISION  
LAWRENCE BERKELEY LABORATORY  
UNIVERSITY OF CALIFORNIA  
BERKELEY, CALIFORNIA 94720