

Lawrence Berkeley National Laboratory

Recent Work

Title

BEAM-PROFILE DETECTOR

Permalink

<https://escholarship.org/uc/item/6cr9d6g2>

Authors

Solomon, Julius
Andreae, Sypko W.

Publication Date

1963-05-20

UCRL-10831

C.2

University of California
Ernest O. Lawrence
Radiation Laboratory

TWO-WEEK LOAN COPY

*This is a Library Circulating Copy
which may be borrowed for two weeks.
For a personal retention copy, call
Tech. Info. Division, Ext. 5545*

BEAM-PROFILE DETECTOR

Berkeley, California

UCRL-10831
C.2

DISCLAIMER

This document was prepared as an account of work sponsored by the United States Government. While this document is believed to contain correct information, neither the United States Government nor any agency thereof, nor the Regents of the University of California, nor any of their employees, makes any warranty, express or implied, or assumes any legal responsibility for the accuracy, completeness, or usefulness of any information, apparatus, product, or process disclosed, or represents that its use would not infringe privately owned rights. Reference herein to any specific commercial product, process, or service by its trade name, trademark, manufacturer, or otherwise, does not necessarily constitute or imply its endorsement, recommendation, or favoring by the United States Government or any agency thereof, or the Regents of the University of California. The views and opinions of authors expressed herein do not necessarily state or reflect those of the United States Government or any agency thereof or the Regents of the University of California.

UCRL-10831

UNIVERSITY OF CALIFORNIA

Lawrence Radiation Laboratory
Berkeley, California

Contract No. W-7405-eng-48

BEAM-PROFILE DETECTOR

Julius Solomon and Sypko W. Andreae

May 20, 1963

Beam - Profile Detector

Julius Solomon and Sypko W. Andreae

**Lawrence Radiation Laboratory
University of California
Berkeley, California**

May 20, 1963

ABSTRACT

A beam-profile detector that employs a pair of continuously-moving scintillation counters as a detector, and a PHA as a multichannel scaler is described. The number of counts per fixed number of incident particles at every 0.1 in. of travel is recorded in consecutive channels of the analyzer. A total of 7 in. is traversed in 42 sec after which the profile may immediately be displayed on the CRT readout of the PHA. The device is useful in its present form at accelerators having high-repetition beam rates. Plans for its adaptation for use at pulsed accelerators are also discussed.

Beam-Profile Detector^{*}

Julius Solomon and Sypko W. Andreae

Lawrence Radiation Laboratory
University of California
Berkeley, California

May 20, 1963

I. INTRODUCTION

In high-energy physics a substantial portion of the experimental time at an accelerator is spent in testing and optimizing the conditions of the various parts of the particle-beam transport system (magnets, quadrupoles, slits, separators, etc.) so that the beam shape and intensity at the target location fulfill the needs of the experiment.

One method of investigating the beam shape is to measure the "beam profile," or the beam count per unit incident flux as a function of position along a line perpendicular to the beam direction. During the optimization procedure, changes are usually made in only one element of the transport system at a time, and after each change accurate beam profiles along two perpendicular lines are required in order to determine the most desirable conditions for operating that element.

This paper describes a beam-profile detector built at the Lawrence Radiation Laboratory at Berkeley, which has reduced the time required to measure and record an accurate beam profile from at least 15 minutes to less than 1 minute. Photographs of the device resting atop the rack of electronics used may be seen in Figs. 1 and 2. The use of pairs of concentric rings and cylinders in the construction allows us to vary about their common axis the orientation of the line along which the profile is taken.

II. GENERAL DESCRIPTION - BEAM PROFILES AND ELECTRONICS

The beam-profile detector uses a pair of "beam finder" scintillation counters that move over a 7 in. linear path. The scintillators are viewed by RCA 1P21 phototubes. The first and defining counter is 3/8 in. in diameter. The second has a diameter of 1.5 in. and is used to provide a double coincidence to minimize the number of accidental counts. Because only one set of counters is used the detection efficiency is uniform for the whole profile. Two 2-in. monitor counters mounted on the axis of rotation of the cylinders detect a reasonable portion of the incident beam so that their counting rate is proportional to the incident flux. The number of beam-finder counts per unit incident flux at every 0.1 in. is consecutively stored in 70 channels of a pulse-height analyzer (PHA). We were able to use a continuously moving carriage because the beam "spill" of the 184-inch synchrocyclotron at 64 cycles per second is essentially continuous.

The beam profiles are accurate in placement to within a 0.1 in., and the accuracy in the number of beam-finder counts recorded is given by the efficiency of the scintillation counters and the fast electronics used. In cases of low counting rates for which the statistics in each channel of the PHA are poor, the overall shape of the profile is still readily discernible. Profiles are completed in 42 seconds, the time it takes to traverse the 7 in., and may immediately be viewed on the CRT readout of the analyzer. A permanent record is kept by photographing the oscilloscope trace or by typing out the PHA memory. As many as four profiles may be stored at one time and compared by overlapping the 400 channels of the PHA. Figure 3 shows the beam profiles taken in the meson cave of the 184-inch cyclotron for a 317-MeV π^- beam having intensity of 3×10^5 /sec and a duty cycle of 60%.

The procedure for taking a profile is the following. With the beam-finder counter pair at one end of its 7-in. travel, the beam-finder counters are set in motion. At each 0.1 in. a microswitch is shorted, setting a flip-flop circuit that turns on the gates to the monitor scalers and the PHA. After a predetermined number of monitor counts has been reached, the monitor scaler puts out a "carry pulse" that resets the flip-flop, thereby turning off the gates to the scalers and PHA, and also after a short delay advances the address of the PHA by one. When the microswitch is closed again, the process repeats itself. At the other end of the 7-in. travel the moving carriage trips a limit switch that turns off the drive motor; this completes the profile.

Figure 4 shows a block diagram of the electronics, and Fig. 5 is a time diagram of the important pulses and dc levels. The system was designed to use only a few special circuits, and mostly uses the standard Lawrence Radiation Laboratory fast electronics¹ along with the RIDL pulse-height analyzer. The special devices are:

- a. A 10-Mc discriminator-prescaler with a variable scale of 1, 2, 4, 8, or 16, used in the beam-monitor circuitry;
- b. A position-pulse generator circuit which takes the shorting of the microswitch and produces a pulse that sets the flip-flop circuit;
- c. A flip-flop circuit, which controls the gates for the scalers and the detector gate of the RIDL; and
- d. A carry-pulse converter, which takes the carry-pulse input and puts out a prompt pulse that resets the flip-flop (thereby turning off the gates), and a delayed pulse, which advances the channel of the PHA. The RIDL PHA was ideal for this device when it was used in the "time" mode; however, any analyzer that has a separate channel advance and a blocking gate may be used.

We have also incorporated here a circuit available at the Lawrence Radiation Laboratory regularly used to gate scalers for turning the detector on and off, and also for gating out any undesirable portion of the beam spill.

Care must be taken that the channel address of the PHA has advanced before the position microswitch is closed a second time, or a channel will be lost and the profile shifted by 0.1 in. All that is required is that the desired number of monitor counts be recorded in the time it takes to travel 0.1 in. This is achieved by checking the beam rate and setting the number of monitor counts to satisfy the above criterion. This number may be varied from 10 to 160,000 counts by prescaling with a multiple of 1, 2, 4, 8, or 16 and scaling at 10, 100, 1000, or 10,000 counts. We have found that this system has given us sufficient leeway at all useful beam levels.

The loss of a channel may also be checked by noting which is the last channel recorded after the full 7-in. sweep is completed. Our experience has been that it takes only a few minutes to vary the monitor parameters so that the profiles taken at a given beam level have the correct number of channels.

We are presently planning to use the main features of this beam-profile detector in a new detector that may be used at both continuous and pulsed machines. We will no longer run the beam-finder counters in a continuous fashion, but will keep the position fixed until the required number of monitor counts is reached. This will eliminate the danger of a possible shift of the beam profile as described above.

One other feature of the profile detector reported here is the flexibility of the electronics. First, the monitor used with the beam finder need not be the counters described here; any other set of counters and coincidence circuits may be used. All that is required is a pulse to drive the precaler. Second,

beam profiles may be taken in coincidence with any other set of counters. The beam-finder coincidence circuit has available one coincidence and one anticoincidence input. Finally, the beam-finder and monitor counters may also be used just as counters (without taking profiles) by removing the gating signal, previously used only for scalars, from the chassis and placing it back on the scalars.

III. GENERAL DESCRIPTION - MECHANICAL

Figures 1 and 2 show the mechanical construction of the beam-profile detector. Cross hairs mounted on the movable cylinders are used to accurately align the position of the device. The platform holding the motor and moving scintillation-counter carriage rotates inside the fixed platform rings and may be set at any angle desired. The carriage holding the scintillators (total weight, 3.5 lb.) is driven along three rails by a 1/70-hp 1725-rpm ac-synchronous Bodine motor geared down by 180 to 1 (see Fig. 6). Three rails are used to eliminate wobble of the carriage. Limit switches at either end of the travel turn off the motor and turn on a Warner magnetic brake (model RF 80) that is attached to the fast shaft of the motor. When the motor is turned off by hand, the brake is capable of stopping the platform within 1/32 in. The limit switches have been set so that there is a total of 7 in. of travel, and so that the center of travel of the defining counter is at the axis of rotation of the cylinders. The total time required to traverse the 7 in. is 0.7 min or 42 sec.

The moving platform carries a microswitch on its underside that is tripped every 0.1 in. by the teeth on a rack mounted below (Fig. 6). The closing of the microswitch is used to produce a pulse that indicates the platform has traveled 0.1 in. Details are given in the preceding section.

A subsidiary system used to indicate the position and direction of travel of the carriage makes use of a 1000- Ω potentiometer with $\pm 0.25\%$ linearity tolerance. The potentiometer is turned by a rack and gear arrangement. The rack is attached to the carriage, and the gear to the potentiometer (see Fig. 6). The voltage across the potentiometer gives the position of the carriage.

ACKNOWLEDGMENTS

We would like to thank Dr. Victor Perez-Mendez, Dr. Barry C. Barish, Dr. Richard J. Kurz, and Mr. Edward Pullen for several informal conferences regarding the requirements of the beam-profile detector. Thanks also to Mr. Lou Sylvia for his many consultations regarding the mechanical design, and also for the fabrication and assembly of the mechanical device. We would also like to thank Mr. Kai Lee, who is responsible for the fabrication and testing of the special electronics.

FOOTNOTE AND REFERENCES

* Work performed under the auspices of the U. S. Atomic Energy Commission.

1 Radiation Laboratory Counting Handbook, Lawrence Radiation Laboratory Report UCRL-3307 (Rev.), Rerun May 1961; Shielded Nanosecond Logic Circuits, S. Klezmer, Lawrence Radiation Laboratory Report UCID-1823, 1962.

FIGURE CAPTIONS

Fig. 1. Beam-profile detector on electronics rack.

- A. Beam-profile detector.
- B. Panel to control movement of the carriage by remote control.
- C. Special electronics rack (2 transistor electronics boards and a special 10-Mc discriminator-prescaler).

Fig. 2. Beam-profile detector (side view).

- A. Beam-finder counters.
- B. Beam-monitor counters.
- C. Cross hairs used for alignment.
- D. Rotatable platform holding motor and movable counter carriage.
- E. Stationary platform used as base for the device.

Fig. 3. (a) Horizontal and (b) vertical beam profiles of a 317-MeV π^- beam in the meson cave of the 184-inch synchrocyclotron. These are photographs of CRT displays on the RIDL PHA.

Fig. 4. Electronics block diagram of beam-profile detector. Descriptions of the standard Radiation Laboratory circuits may be found in reference 1.



"And" (coincidence) circuit.



"Or" (mixer) circuit.



Tunnel diode discriminator model 4X6381-18.



Tunnel diode discriminator model 4X1111-9.



Tunnel diode discriminator 5X2954-3.



Pulse amplifier

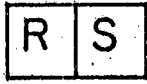

Flip-flop circuit (S = set, R = reset).

Fig. 5. Time diagram of the important pulse shapes and dc levels for the profile detector.

Fig. 6. Closeup view of motor and movable counter carriage.

- A. Carriage holding beam-finder counters. Magnetic shields of 1P21 phototubes are visible on carriage.
- B. Microswitch under the carriage which is tripped every 0.1 in. by teeth on rack.
- C. Auxilliary position potentiometer.
- D. Limit switch.
- E. Motor and drive mechanism.

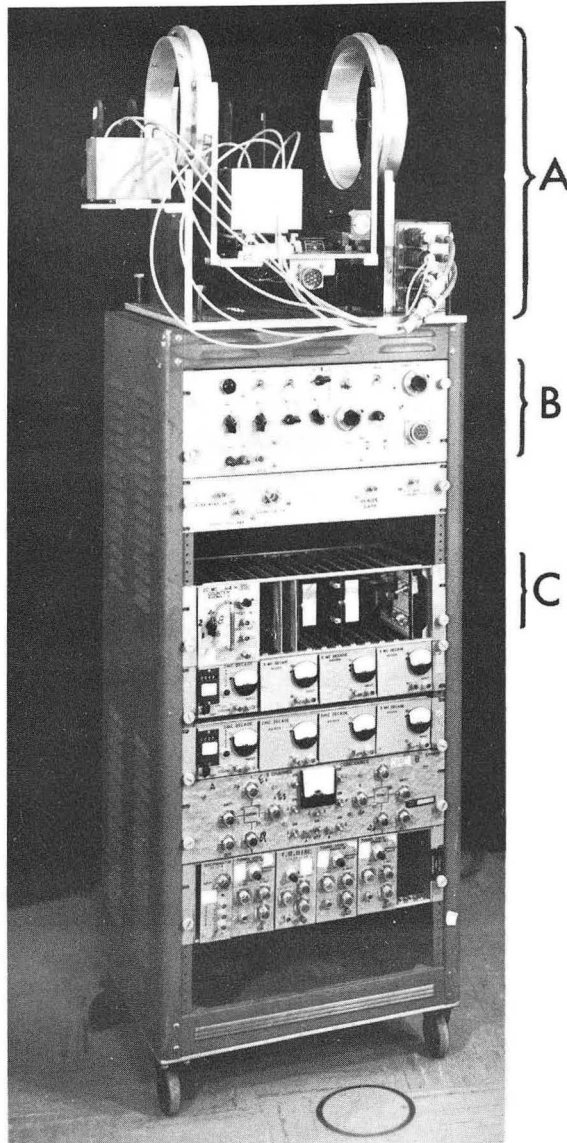

ZN-3772

Fig. 1

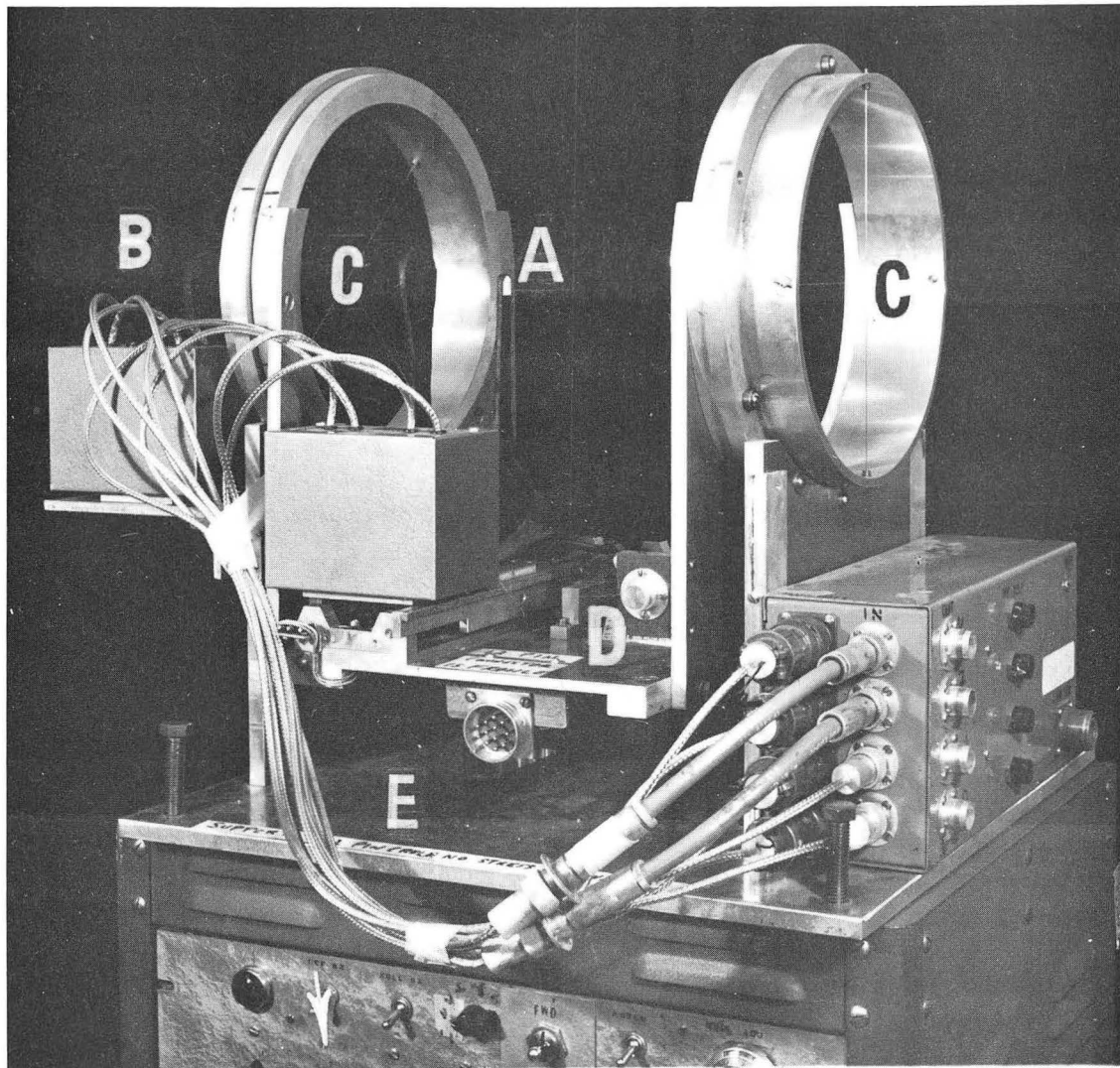

ZN-3771

Fig. 2

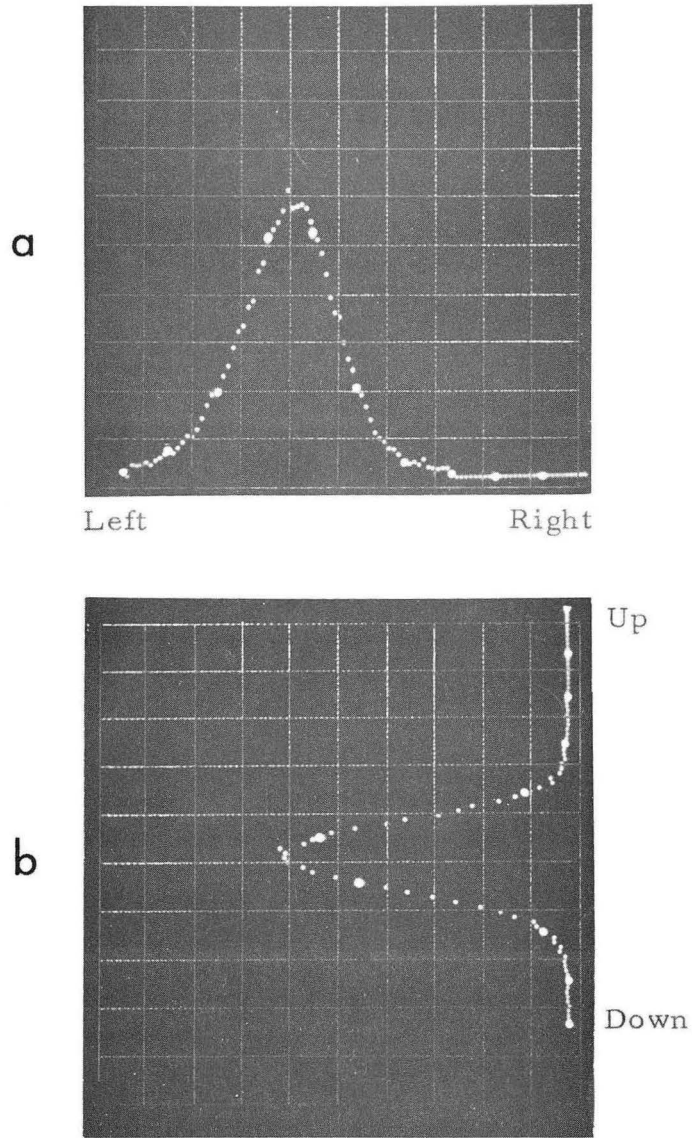

ZN-3770

Fig. 3

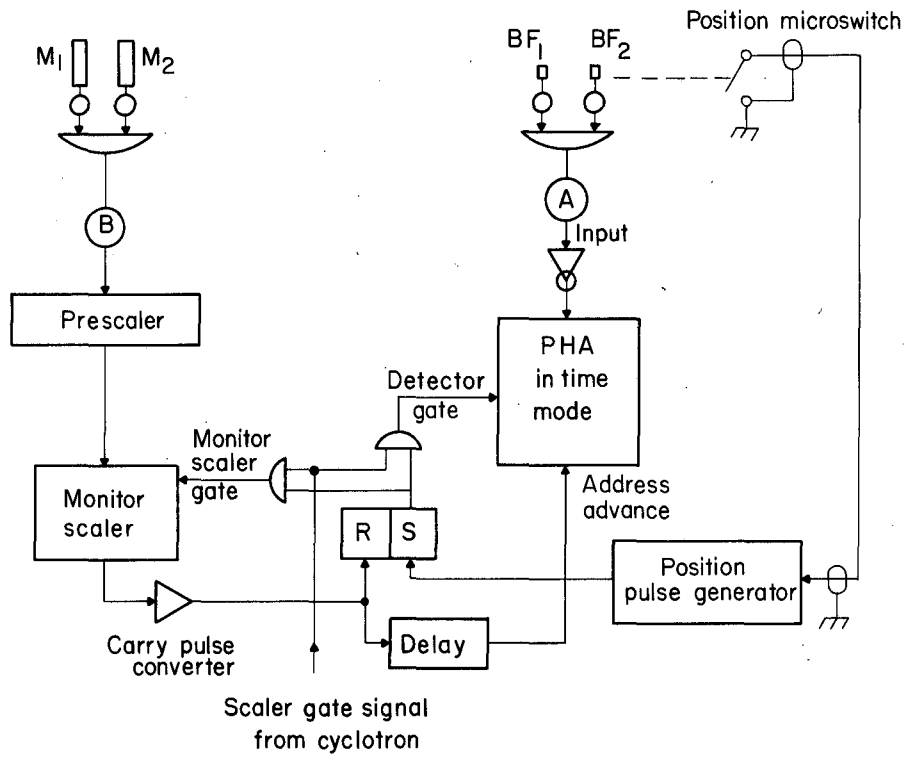

MU-30584

Fig. 4

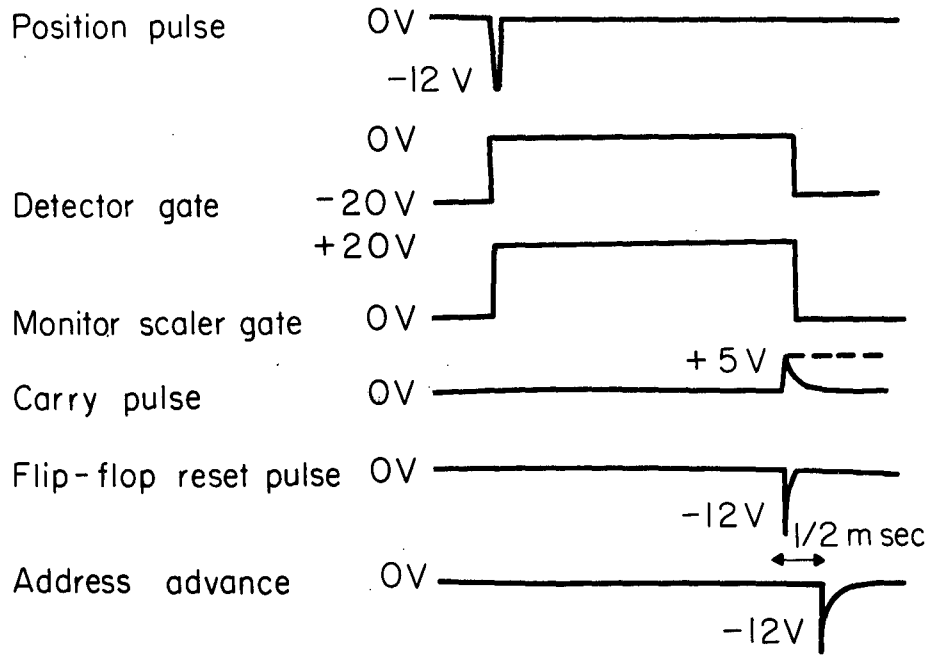

MU-30583

Fig. 5

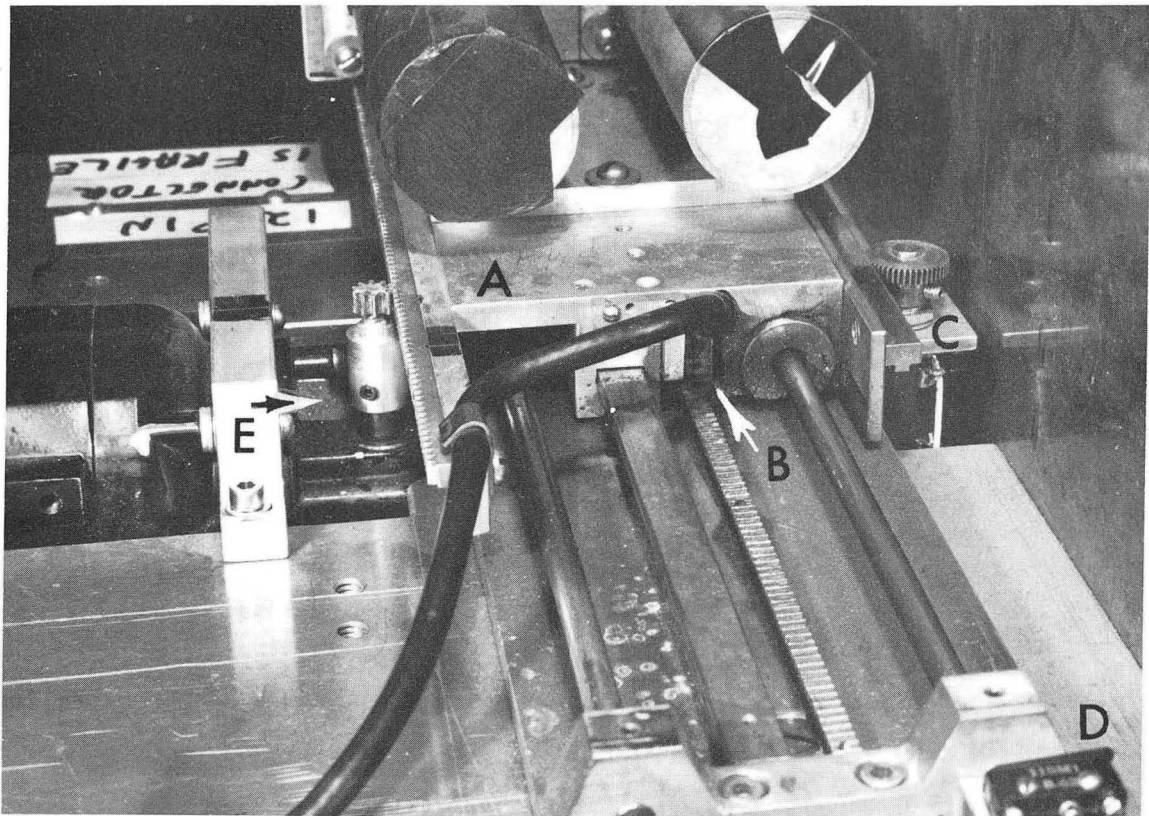

ZN-3773

Fig. 6

LEGAL NOTICE

This report was prepared as an account of Government sponsored work. Neither the United States, nor the Commission, nor any person acting on behalf of the Commission:

A. Makes any warranty or representation, expressed or implied, with respect to the accuracy, completeness, or usefulness of the information contained in this report, or that the use of any information, apparatus, method, or process disclosed in this report may not infringe privately owned rights; or

B. Assumes any liabilities with respect to the use of, or for damages resulting from the use of any information, apparatus, method or process disclosed in this report.

As used in the above, "person acting on behalf of the Commission" includes any employee or contractor of the commission, or employee of such contractor, to the extent that such employee or contractor of the Commission, or employee of such contractor prepares, disseminates, or provides access to, any information pursuant to his employment or contract with the Commission, or his employment with such contractor.

[The page contains extremely faint, illegible text, likely bleed-through from the reverse side of the document. The text is arranged in several horizontal lines across the page.]

