

UC Irvine

UC Irvine Previously Published Works

Title

Autoponics: An Automated Hydroponics System

Permalink

<https://escholarship.org/uc/item/6ch3331g>

Authors

Zublin, Emil
Skinner, Derek
DeOrlow, Diego
[et al.](#)

Publication Date

2023-03-15

Supplemental Material

<https://escholarship.org/uc/item/6ch3331g#supplemental>

Copyright Information

This work is made available under the terms of a Creative Commons Attribution License, available at <https://creativecommons.org/licenses/by/4.0/>

Peer reviewed



Autoponics

Emil Zublin, Derek Skinner, Diego DeOrlow, Jaehyeok Jeon
Professor QV Dang
Department of Electrical Engineering and Computer Science



Why Autoponics?

Our goal is to create an automated hydroponic system that is intuitive and flexible. The annual market share for hydroponics has risen by 20% [1], which highlights the increasing demand for hydroponics. Additionally, there have been studies indicating that it is feasible for universities to implement vertical farming techniques, including hydroponics, to make a return on investment[3]. Therefore, we aim to create an automation system that is beginner-friendly, and can be easily installed to existing hydroponic system basins.

The most important part of any hydroponic system is maintaining a perfectly balanced nutrient solution[2]. Autoponics will precisely monitor the hydroponic systems solution using sensors, and automatically adjust it to optimal levels using peristaltic pumps, while allowing for customization on pH and EC thresholds.

Software

The firmware of the main chip is built on top of FreeRTOS, allowing each sensor and each pump to work independently on their own “tasks”, which are essentially lightweight threads. Our motivation in using an RTOS is that each sensor works independently, allowing us to separate concerns inside of the source code very easily. It also allows for a priority of tasks to be set. Additionally, we make use of the ESP-IDF libraries for interfacing with the built-in ESP32 ADC channels and the I²C channels.

The GUI is run separately on the ESP32 integrated WT32-SC01 display. It utilizes the LVGL graphics library, and communicates with the main chip using I²C connection. The touchscreen capabilities of the GUI allows the user to raise or lower the pH and EC threshold values depending on their goals and which plants they want to target.

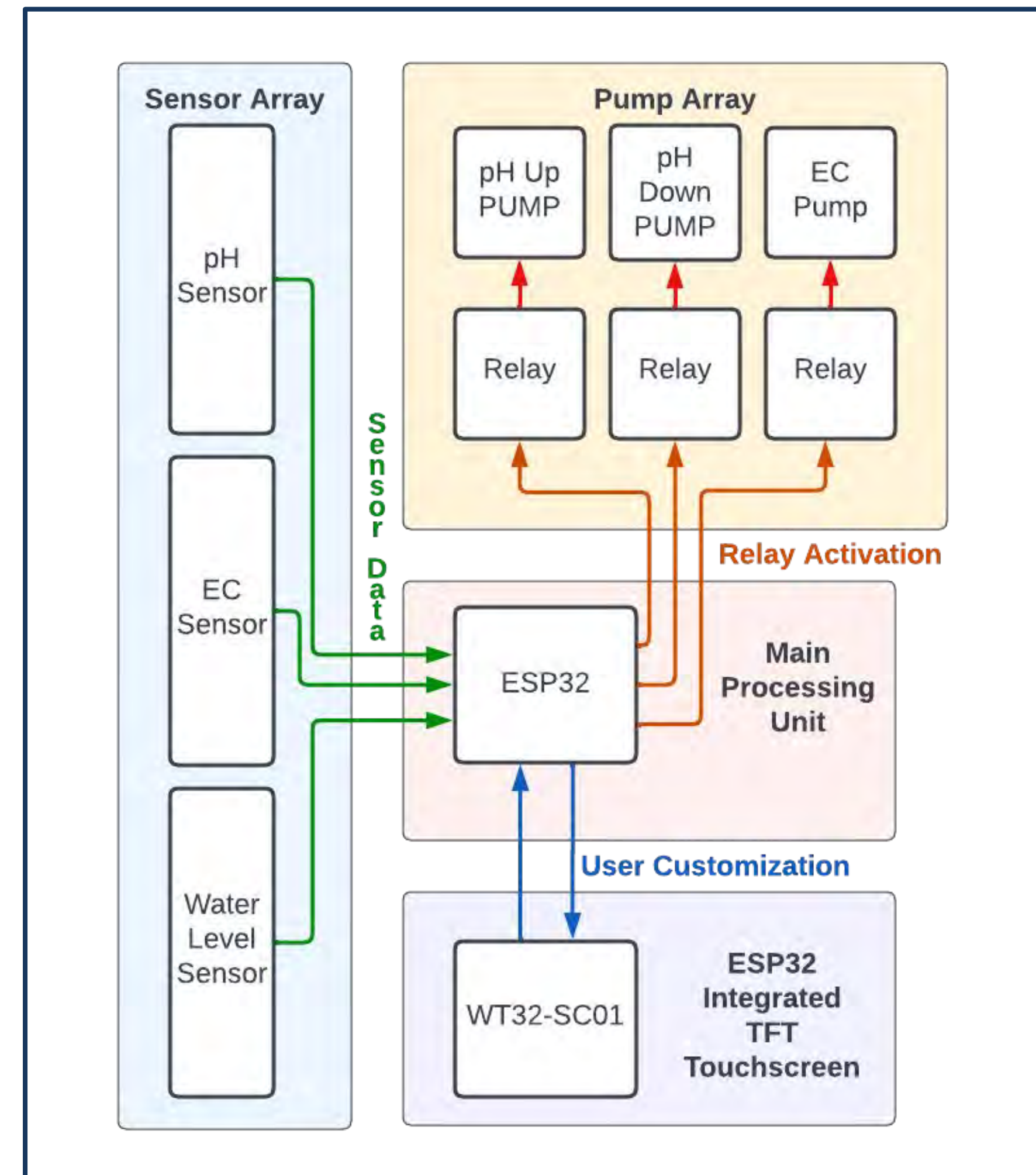

Figure 1: System Schematic



Figure 2: Rendered CAD of a complete system

System extensibility

Autoponics aims to make hydroponics more accessible. Users can replicate or modify the Autoponics system by adding additional sensors or providing different pH and EC sensor implementations in the source code. Additionally, there are many possible system configurations. Users could set up an entire grid of buckets or pipe utilizing the Autoponics firmware and sensors.

Methods

- The sensors measure the pH, water level, temperature and electrical conductivity in the water reservoir.
- An air pump and airstone oxygenate and circulate the water.
- A touchscreen TFT display displays current metrics, with a user interface for pH and EC customization.
- An array of peristaltic pumps handle automatic dispensing of pH adjusting and nutrient solution.



Figure 3: TFT display graphic interface monitor and settings menu

Materials

- ESP32 microcontroller
- WT32-SC01 display
- DFRobot pH Meter Pro V2
- The cables and sensors have IP67 rated waterproofing.
- The system as a whole uses approximately 10W.
- DFRobot EC Meter Pro
- DFRobot Liquid Level sensor
- Peristaltic pump array w/ relays

References

- [1] “Hydroponics Market Size & Share Report, 2021-2028.” <https://www.grandviewresearch.com/industry-analysis/hydroponics-market>.
- [2] W. F. Gericke, “Crop Production without Soil,” *Nature*, vol. 141, no. 3569, Art. no. 3569, Mar. 1938, doi: [10.1038/141536a0](https://doi.org/10.1038/141536a0).
- [3] H. Zhang, A. Asutosh, and W. Hu, “Implementing Vertical Farming at University Scale to Promote Sustainable Communities: A Feasibility Analysis,” *Sustainability*, vol. 10, no. 12, Art. no. 12, Dec. 2018, doi: [10.3390/su10124429](https://doi.org/10.3390/su10124429).