

UC Irvine

UC Irvine Previously Published Works

Title

Understanding and treating arm movement impairment after chronic brain injury: progress with the ARM guide.

Permalink

<https://escholarship.org/uc/item/65z7c4s7>

Journal

Journal of rehabilitation research and development, 37(6)

ISSN

0748-7711

Authors

Reinkensmeyer, D J
Kahn, L E
Averbuch, M
et al.

Publication Date

2014-11-21

Peer reviewed



Understanding and treating arm movement impairment after chronic brain injury: Progress with the ARM guide

David J. Reinkensmeyer, PhD; Leonard E. Kahn, BS; Michele Averbuch, PT; Alicia McKenna-Cole, PT; Brian D. Schmit, PhD; W. Zev Rymer, MD, PhD

Department of Mechanical and Aerospace Engineering, Center for Biomedical Engineering, University of California at Irvine, Irvine, CA 92697; Sensory Motor Performance Program, Rehabilitation Institute of Chicago, Department of Physical Medicine and Rehabilitation, Northwestern University Medical School, Chicago, IL 60611

Abstract—Significant potential exists for enhancing physical rehabilitation following neurologic injury through the use of robotic and mechatronic devices (or “rehabilitators”). We review the development of a rehabilitator (the “ARM Guide”) to diagnose and treat arm movement impairment following stroke and other brain injuries. As a diagnostic tool, the ARM Guide provides a basis for evaluation of several key motor impairments, including abnormal tone, incoordination, and weakness. As a therapeutic tool, the device provides a means to implement and evaluate active assist therapy for the arm. Initial results with three stroke subjects demonstrate that such therapy can produce quantifiable benefits in the chronic hemiparetic arm. Directions for future research regarding the efficacy and practicality of rehabilitators are discussed.

Key words: *arm movement, rehabilitation, robotics, stroke.*

This work was supported in part by Grant H133G80052 from the National Institute for Disability and Rehabilitation Research, 400 Maryland Avenue, SW, Washington, DC 20202, and a Whitaker Foundation Biomedical Engineering Research Grant, 1700 North Moore Street, Suite 2200, Rosslyn, VA 22209.

Address all correspondence and requests for reprints to: David J. Reinkensmeyer, PhD, University of California, Department of Mechanical and Aerospace Engineering, 4200 Engineering Gateway, Irvine, CA 92697-3975; email: dreinken@uci.edu.

INTRODUCTION

Stroke is a leading cause of severe disability in the United States, with over 500,000 people experiencing a new stroke each year, and over 2,000,000 persons chronically affected (1). In addition, traumatic brain injury impairs the movement of hundreds of thousands of more individuals each year. Loss of voluntary arm movement is common after stroke and traumatic brain injury, with approximately 85 percent of stroke patients incurring acute arm impairment and 40 percent chronic impairment (2). Surprisingly little technology is currently available to treat the arm, even though many rehabilitation techniques are mechanical in nature. Automation of these techniques could reduce the cost and enhance the delivery of therapy.

Motivated by these needs, there is increasing interest in developing robotic and mechatronic devices (or “rehabilitators”) for physical rehabilitation of the arm following brain injury (3–5). A key problem that limits effective design of rehabilitators, however, is that the mechanisms of arm movement recovery following brain injury are not well understood. For example, the role in

recovery played by cortical reorganization, as compared with peripheral changes in muscle and reflex function, is unclear. For the present, most rehabilitators have emulated a technique called "active assist exercise," which is commonly administered by physical and occupational therapists. In active assist exercise a desired movement is manually completed for the patient if he or she is unable to complete it on his or her own. Other manual therapy techniques, including sensory facilitation techniques or resistance methods, could also potentially be implemented by rehabilitators (6).

Manual therapy techniques could enhance recovery by a number of mechanisms, the relative importance of which is not clearly understood. For example, active assist therapy could maintain passive range of motion, reduce spasticity, improve muscle strength, or encourage cortical reorganization by providing sensory stimulation. Resistance exercises and facilitation methods could also enhance strength and reduce unhelpful muscle synergies, defined as abnormal, stereotypic coupling between movements of adjacent joints.

We have recently developed a rehabilitator, "the ARM Guide" (Assisted Rehabilitation and Measurement

Guide), in order to study these issues (references 7,8; Figure 1). Our primary objectives in developing a rehabilitator were, first, to provide an improved diagnostic tool for assessing arm movement impairment after brain injury, and, second, to provide a therapeutic tool for exploring the effects of active assist therapy. This paper briefly summarizes the device design, and reviews current progress on both the diagnostic and therapeutic objectives.

DESIGN OF THE ARM GUIDE

Reaching was chosen as the target arm movement task for the ARM Guide because it is fundamental to many activities of daily living. Also, an exploitable feature of reaching movements is that they typically follow approximately straight-line trajectories. This feature allowed use of a passive, linear constraint with a single motor to assist in arm movement, rather than a robot system with multiple active degrees of freedom (DOF). The resulting system is simple and relatively inexpensive.

To use the ARM Guide, the subject's forearm/hand is strapped to a specially designed splint that slides along the

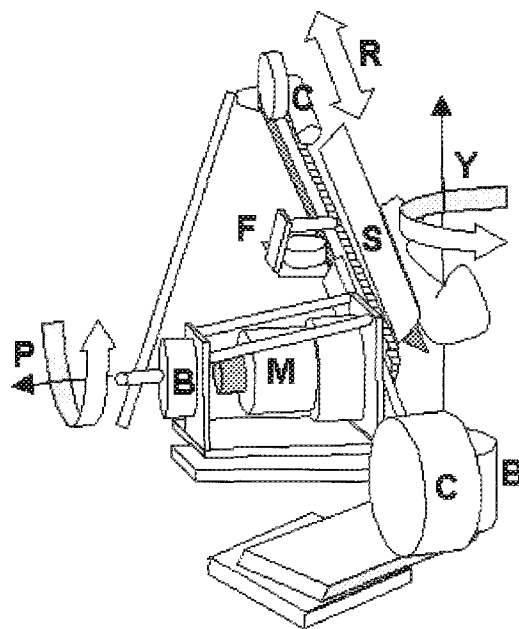
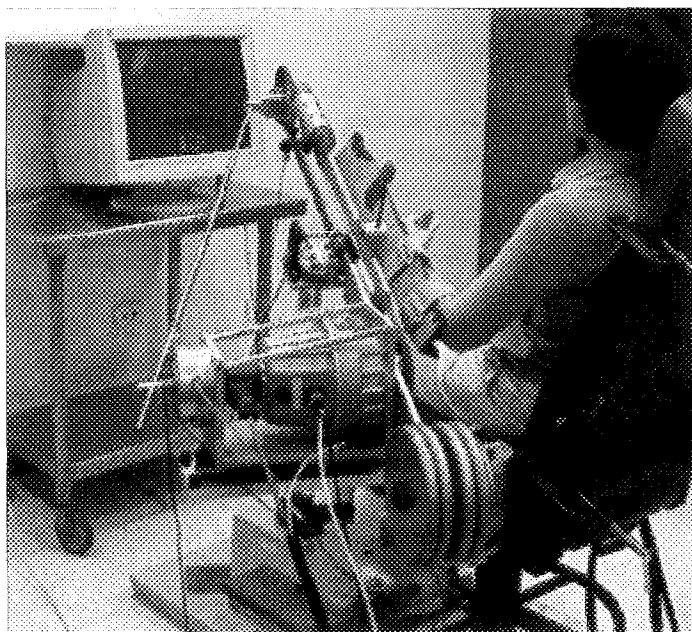

Figure 1.

The ARM Guide. Left: The user is attached to a splint that slides along a linear bearing. A motor assists or resists arm movement along the linear bearing. The orientation of the linear bearing can be changed in the vertical and horizontal planes. The user receives feedback about movement and force generation of the arm on a video monitor. Right: Details of the mechanical structure of the device. S: splint; M: motor; B: brake; F: force/torque sensor; C: counterbalance. The three degrees of freedom of the device are R: reach (actuated by the motor), Y: yaw (actuated by a brake), and P: pitch (actuated by a brake).

linear constraint (Figure 1). To apply force to the arm, the motor drives a chain drive attached to the splint. An optical encoder attached to the motor measures the arm position. A six-axis load cell mounted between the splint and the linear constraint measures the forces generated by the arm.

The orientation of the ARM Guide can be manually changed in the vertical and horizontal planes, and locked with computer-controlled magnetic particle brakes, allowing reaching at different elevation and yaw angles. Also, the device is mounted on a telescoping stand for height adjustment, and can be flipped to measure reaching with the left or right hand. The device is counterbalanced such that the user splint remains at any position and orientation at which it is placed along the linear constraint, at any elevation angle. As a result, the user experiences no static loading of the arm due to the weight of the device.

ASSESSING THE HEMIPARETIC ARM WITH THE ARM GUIDE

Our first objective in developing the ARM Guide was to provide an improved diagnostic tool for assessing arm movement impairment after brain injury. This section reviews a series of techniques that were developed to diagnose the relative effects of several common motor impairments. These impairments are abnormal tone, spasticity, and incoordination (6).

Assessing Tone

Tone is clinically defined as the resistance to externally imposed movement of a passive limb. Quantifying tone with the ARM Guide is straightforward: The subject is instructed to relax, and the motor slowly extends the arm along the linear bearing. Movement at a slow enough rate avoids excitation of stretch reflexes (8,9), and minimizes the effect of inertial forces. Using this technique, we have found that the force required to hold the arm in an extended position is consistently increased in the chronic hemiparetic arm, as compared to the contralateral arm (significant increase in 10 of 11 subjects tested, *t*-test, $p < .05$, e.g., Figure 2). Joint torque analysis indicated that this increase is likely attributable to muscle- or joint-based contracture at both the shoulder and elbow (8), due to disuse of the hemiparetic arm (10).

Assessing Spasticity

Spasticity is defined as a velocity-dependent increase in stretch reflexes, and is clinically assessed by

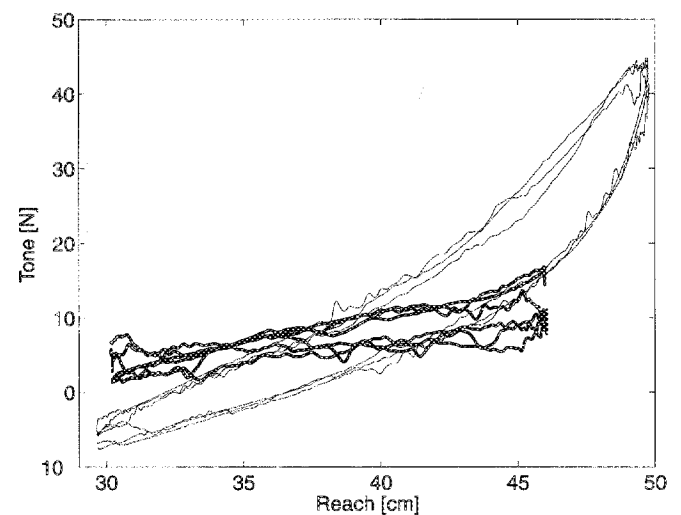

Figure 2.

Tone of impaired arm (thin line) and contralateral arm (thick line) of a chronic hemiparetic stroke subject during slow movement of the arm along the ARM Guide. Eight slow movements were performed for each arm.

manually stretching a selected muscle group with the patient relaxed. As has long been recognized (e.g., 11), spasticity could disturb voluntary movement by causing inappropriate activation of antagonist muscles as these muscles are stretched. This possibility has been assessed with the ARM Guide in several ways.

In one assessment technique, the active stiffness of the arm at the end of its active range of motion (i.e., at the "workspace boundary") was quantified (8). If spastic reflexes are activated during reaching and persist in restraining movement, the stiffness of the arm should be increased following active as opposed to passive movement to the workspace boundary. To measure this stiffness increase, five subjects with clinically identified spasticity moved as fast and as far as possible, and the ARM Guide applied a small stretch to the arm 150 msec after the arm stopped moving. Subjects were instructed to keep attempting to move farther when their arm stopped moving, and thus were activating muscles when the stretch was applied. For comparison, an identical terminal stretch was applied following passive movement of the arm through the same range. The same procedure was repeated for each subject's contralateral, unimpaired arm, with a movement matched in amplitude and peak velocity.

The key findings were that arm stiffness increased following active movement, but that the increase was comparable in the spastic and contralateral arms of each

subject. Thus, active arm stiffness in the spastic arm is not excessive, relative to normal active stiffness. This result suggests that agonist weakness, rather than restraint from antagonist muscles arising from spasticity (or more generally, arising from any abnormal co-contraction mechanism), primarily determines workspace limitations.

An interesting result was seen in the only subject who manifested consistent stretch reflexes during the terminal stretch. This subject showed reduced stretch reflex magnitude during voluntary movement as opposed to during passive movement (Figure 3). This indicates, as has been suggested before (12), that spastic stretch reflexes may even be decreased in some subjects during voluntary movement.

In a companion experiment (8), we explored whether subjects could move farther if any (potentially small) spastic reflexes that were excited during reaching were allowed to dissipate at the workspace boundary. Specifically, the ARM Guide created a virtual wall at the workspace boundary, and the subject initiated movement after resting on this wall and achieving a relaxed state. In this situation, subjects could reliably move farther, but only by a small amount (1–2 cm). This implies that a preceding voluntary movement to the workspace boundary effectively weakens the arm. A simple explanation of this “movement-generated weakness” is that spasticity contributes a small amount of restraint to reaching. In light of the aforementioned stiffness experiment, this “small amount” is apparently comparable to normal levels of co-contraction during targeted movement.

A third assessment technique has recently been used to explore the contribution of spasticity during movement, rather than at the end of movement. In this technique, the subject initiates movement, reaching as far and fast as possible, and the ARM Guide drives the arm along a preprogrammed smooth trajectory through the arm's full active range of motion. This process is repeated for an imposed trajectory with peak velocities ranging from 1 cm/sec to three times the person's maximum voluntary velocity. Depending on the subject's ability and on the programmed velocity, the motor either accelerates or resists the movement generated by the muscles. If the forces due to the passive length-tension relationship of the arm are measured and subtracted out, the active force generated by the arm at the peak velocity of movement should resemble the Hill force-velocity relationship.

Preliminary results with two subjects indicate that arm force generation follows a Hill-like force-velocity relationship at lower velocities. However, at what appears

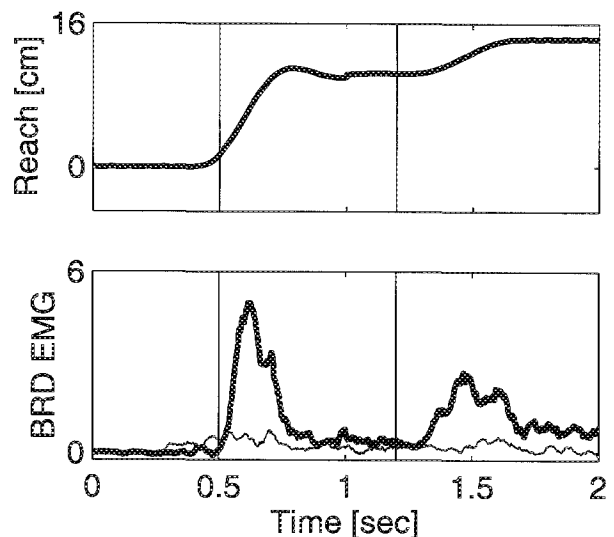

Figure 3.

Example showing a decrease in a spastic stretch reflex during voluntary movement for one subject. The subject performed a fast-as-possible and a far-as-possible movement along the ARM Guide, which was followed immediately by a 4-cm terminal stretch (thin line, covered by thick line in top graph). Then, the subject was asked to relax, and the ARM Guide imposed an identical movement on the relaxed arm, again followed by a 4-cm terminal stretch (thick line). Ten such voluntary and imposed movements were alternated, aligned at a small velocity threshold (first vertical line) and at the beginning of the terminal stretch (second vertical line), and averaged. During the imposed movement, brachioradialis (BRD—an elbow flexor) exhibited a strong electromyogram response, both during the first part of the movement, and during the terminal stretch (thick line, bottom). The BRD response was reduced during voluntary movement and during the terminal stretch following the voluntary movement (thin line, bottom).

to be a threshold velocity (V_{th}) there is a departure from the Hill-like curve, and an increase in the resisting force generated by the arm (Figure 4). We hypothesize that this increase is due to the activation of spastic stretch reflexes. For the two subjects tested, the increase occurs at a threshold velocity greater than the subject's maximum voluntary movement velocity. Thus, we tentatively suggest that spastic reflexes are not encountered during normal reaching by these subjects.

Assessing Incoordination

Another common consequence of stroke is incoordination. Disturbances in coordination have been clinically characterized as “abnormal muscles synergies,” in which there appears to be relatively tight coupling of motion at adjacent joints, due to coactivation of muscles in rigid, or stereotypic, patterns. Brunnstrom (13) classified post-

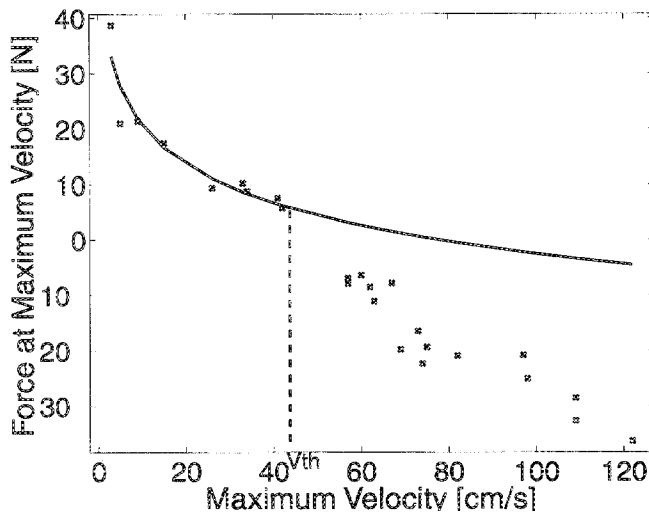

Figure 4. Force-velocity profile for a chronic stroke subject. The solid curve represents a negative power fit to the data before the threshold velocity (V_{th}) to approximate the Hill force-velocity relationship. The dotted line demarcates where the data skew from the Hill relationship, signifying activation of spastic stretch reflexes resisting movement.

stroke synergies broadly as either flexor type (shoulder abduction and external rotation, elbow flexion) or extensor type (shoulder adduction and internal rotation, elbow extension). In order to quantify abnormal synergies with the ARM Guide, the forces generated perpendicular to the

intended direction of movement (i.e., "off-axis" forces) during guided reaching can be measured (7,8). Using this technique, we have found that hemiparetic subjects often exhibit large off-axis forces particularly in the horizontal plane, and that these forces are indeed consistent with the abnormal flexion and extension synergies. For example, subjects generate a large medially directed off-axis force during extension of the elbow, consistent with the shoulder internally rotating and adducting (i.e., the extension synergy, **Figure 5**). Similar impaired directional force control has also been observed for severely impaired stroke subjects with the MIME rehabilitator (4).

Summary: A Rehabilitator-Generated Picture of Movement Impairment After Brain Injury

The application of these assessment procedures identified three impairments that limit arm movement in chronic brain injury: increased tone, incoordination (characterized as lack of directional force control or "abnormal synergies"), and agonist weakness. Spasticity (and more generally, abnormal co-contraction) apparently plays a lesser role, consistent with other recent studies (14,15). Since the effects of brain injury are diverse depending on the location and extent of the lesion and the subject's rehabilitation history, the relative roles of these impairments likely vary between subjects and within a single subject over time. The assessment techniques out-

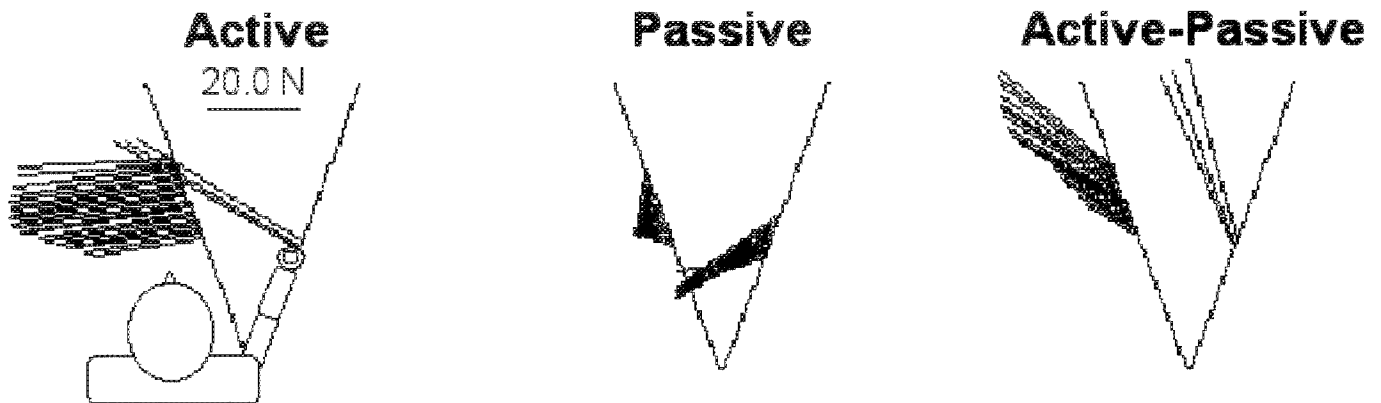

Figure 5. Example of assessment of incoordination. Data is from a female, chronic hemiparetic, traumatic brain-injured subject. Subject reached at a comfortable speed ten times as far as possible, or underwent four slow passive movements with the arm relaxed, with the ARM Guide locked in two orientations (yaw=22.5, elevation=+30). Shown is the top view of the forces generated during active and passive movement. Active: The force difference between the impaired and unimpaired arms during active reaching at matched speeds. Note that the impaired arm differentially generates a large, medially directed force in both ARM Guide orientations, consistent with the abnormal extension synergy. Passive: The difference between impaired and unimpaired arms during slow, imposed movement with the subject relaxed. Note that the impaired arm prefers a more internally rotated, flexed posture, resisting movement outward along the guide. Active-Passive: The difference between active and passive movement for the impaired arm. Note the impaired directional force control, due to active contraction of muscles.

lined here provide a means to diagnose their relative importance on an individualized basis, as well as to monitor their treatment.

TREATING THE HEMIPARETIC ARM WITH THE ARM GUIDE

The second objective in developing the ARM Guide was to provide a therapeutic tool for exploring the effects of active assist therapy. This section reports the first results of using the ARM Guide to deliver such therapy to chronic stroke subjects.

Rationale and Design of Active Assist Therapy

Although active assist therapy can be implemented in a variety of ways, its essential principle is to complete a desired movement for the patient if the patient is unable to do so. Based on the diagnostic picture painted by the ARM Guide, this approach is suitable for treating arm movement impairment in chronic stroke (16). Specifically, active assist therapy interleaves repetitive movement exercise and passive range of motion exercise. Repetitive movement exercise—i.e., repetitive effort by the patient to initiate and control movement—allows the patient to practice activating damaged and/or alternate motor pathways, potentially improving the efficacy and reliability of those pathways. Passive range of motion exercise repetitively extends shortened soft tissues, facilitating the remodeling of those tissues and reducing heightened tone (10).

A potential drawback of active assist therapy, however, is that it could encourage incoordination. That is, a patient may be able to develop more force for reaching by using an abnormal muscle synergy, since any misdirected (i.e., off-axis) forces will be counteracted by the mechanical assistance. One way to address this drawback is to incorporate feedback for off-axis force generation, to allow the patient to monitor and develop coordinated movement. A simple way to achieve this feedback is to reduce the stiffness of the guiding mechanism, such that if the patient exerts large off-axis forces, his or her arm will deviate from the desired reaching path. As described below, this approach was used in this study. Incorporation of compliance (through impedance control) has also been advocated for safety reasons in the design of the MIT-MANUS arm rehabilitator (3).

Based on this rationale, an active assist control algorithm was designed for the ARM Guide that allows the

subject to initiate movement, completes the movement in a smooth fashion if the subject is unable to do so, and provides feedback of incoordination (17). To achieve assistance, the proportional/derivative position feedback controller is activated when the subject reaches beyond the start position by a small window, r_s . The controller then drives the arm along a minimum-jerk desired position trajectory, with the initial position of the desired trajectory matched to the start condition when the subject leaves the initial window, and the final position set at the subject's full passive range of motion. A position dead-band of width d is placed around the desired trajectory, such that if the subject follows the desired trajectory within this dead-band, the motor does not apply force (cf. 18,19). Also, the gains of the position feedback controller are exponentially increased from zero to a final (stiff) value with a time constant t . Exponentially increasing the gains guides the arm smoothly toward the desired trajectory at the beginning of movement, while ensuring that the desired range of arm movement is completed if the subject is unable. For the experiments described below, the parameter values of the controller were $r_s=0.5$ cm (Subjects A and C) or 0.3 cm (Subject B), $d=1.0$ cm, and $t=1.0$ sec.

To provide feedback of abnormal coordination, passive compliance was built into the ARM Guide in the yaw and pitch directions (i.e., horizontal and vertical rotation). In the yaw direction, an elastic cable chain was attached between the magnetic particle brake and the linear guide (resulting compliance=0.09 Nm/deg). In the pitch direction, a stainless steel rod connects the magnetic particle brake to the linear guide (resulting compliance=0.14 Nm/deg). A visual display was designed that shows a desired target window for yaw and pitch, and the actual yaw and pitch angles to the subject during reaching (Figure 1).

Training Protocol

Three subjects have trained with the ARM Guide using this control algorithm. Subjects A and B were both female, aged 38 and 31 years, 6 and 2 years post-stroke, respectively; left hemiparetic after hemorrhagic stroke; with Chedoke-McMaster Arm Impairment scores of 2 out of a possible 7. Subject C was a male aged 54 years, 5 years post-stroke, left hemiparetic after hemorrhagic stroke, with a Chedoke-McMaster arm score of 3. (A Chedoke arm score of 2 corresponds roughly to having some active movement at the elbow, but not being able to touch the chin; a score of 3 typically corresponds to hav-

ing difficulty lifting the arm above the shoulder with the elbow straight; reference 20.) Subjects A and C underwent three training sessions per week over a two-month period, while Subject B completed three sessions per week over a one-month period.

For each training session, the subjects were securely strapped to a chair to prevent torso movement, and the axis of rotation of the ARM Guide motor was aligned with the subject's elbow, with the arm at 0° shoulder flexion (i.e., parallel to gravity). The training session consisted of ten assisted movements made to a series of five targets, distributed in one of five directions across the subject's workspace (ranging from 22.5° guide yaw, and 0° to 45° guide elevation). Subjects were instructed to move as fast and as far as possible, and the peak velocity of the desired trajectory along the ARM Guide was set to the mean peak velocity measured during free-reaching movements with the unimpaired arm. If the subject was incapable of initiating movement herself after several attempts and verbal encouragement, the experimenter manually initiated movement by triggering the motor with the computer. Subjects also received visual feedback of the actual elevation and yaw angles of the ARM Guide on a computer monitor (Figure 1), and were instructed to keep the ARM Guide oriented toward the desired target during reaching using this feedback. Training sessions lasted approximately one hour.

Assessment Protocol

Each subject underwent three pre-training assessment sessions, and three (Subjects A and C) or two (Subject B) post-training assessment sessions. Each assessment session consisted of three portions. First, the tone of the subject's arm was characterized by slowly moving the arm out and back along the device, with the device locked in 0 yaw and 0 elevation (i.e., straight ahead and horizontal). Second, the subject reached as far and as fast as possible ten times along the ARM Guide without receiving assistance from the motor, and the subject's unassisted range of movement and peak velocity, as well as off-axis force generation, were quantified. Third, the ability of the subject to reach in free space (i.e., unattached to the ARM Guide) was quantified. Starting with their hand in their lap, the subjects reached ten times each to five targets distributed across their workspace in positions matched to the ARM Guide training directions, and one target in an untrained direction. An electromagnetic motion tracker (Ascension Technologies, Inc.) fastened to the back of the wrist measured reaching kinematics. Care

was taken to eliminate metal from the environment of the tracker, such that the measured position measurement accuracy was better than 1 cm.

Training Results

The two most impaired subjects (Subjects A and B) had greatly decreased active range of motion along the ARM Guide at the onset, but with training, improved their active range (Figure 6). Subject C had full active range of motion along the ARM Guide from the onset. All three subjects improved peak velocity of movement along the ARM Guide with training (Figure 6). In addition, the tone of Subjects A and B, quantified as the force required to hold the passive arm in an extended position (i.e., at approximately 120–140° of elbow extension) was elevated (compared to the contralateral arm) before training, but decreased significantly with training. The peak off-axis force generated during reaching, the measure of incoordination described above, decreased for Subject A, while it increased for Subject B and remained the same (at an approximately normal value) for Subject C.

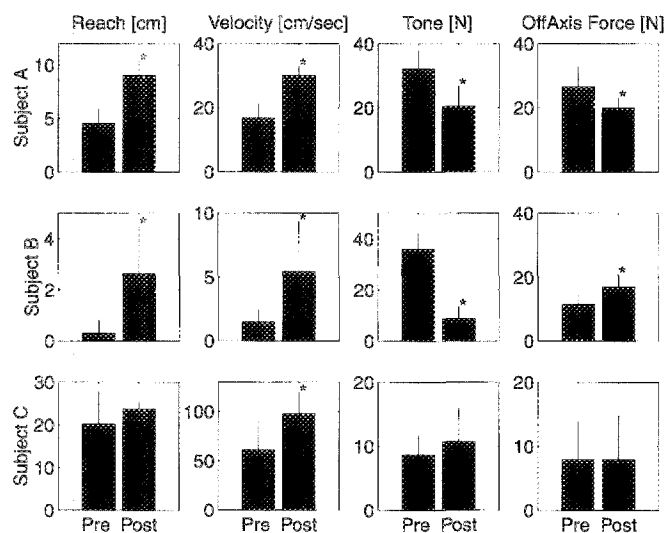

Figure 6.

Changes with active assist therapy in maximum reach and velocity, passive restraint force with the arm in an extended position, and peak-off-axis force during unassisted movement along the ARM Guide. Bars show one standard deviation; asterisk indicates significant difference, *t*-test, $p < 0.01$.

The two severely impaired subjects also improved their ability to initiate movement in problematic directions. At the onset of training, Subjects A and B could not reliably initiate movement when the ARM Guide was oriented such

that the shoulder was externally rotated. With practice, however, both subjects were able to trigger these externally rotated movements more consistently (Figure 7). For one subject, significant improvements were seen after only one week of training (three training sessions). Subject C was able to initiate all movements through the entire training program and thus is not included in Figure 7.

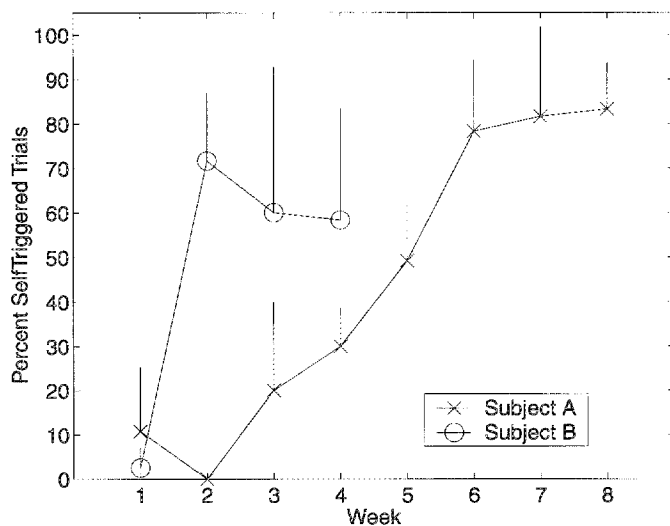

Figure 7.

With training, both subjects initiated movement more reliably in ARM Guide orientations with the shoulder externally rotated. Each point is the average of three training sessions. Bars show one standard deviation.

Transfers of the improvements in movement measured with the ARM Guide to free-reaching kinematics were also evaluated. Subjects A and C improved their free ranges of motion with training, while Subject B did not (Figure 8). Free range of motion did not improve for reaches in the test direction in which training with the ARM Guide did not occur (Target 1, Figure 8). Subject C also showed decreased variability in achieving his maximum free range (Figure 8).

Summary: Effects of Rehabilitator-Assisted Therapy

Active assist therapy produced several quantifiable benefits. Tone was reduced in the two subjects in whom it was elevated at onset, and active range of motion, peak velocity, and the ability to initiate movement also improved. We hypothesize that these improvements are the results of repetitive stretching of soft tissues, coupled with repetitive practice in activating damaged motor pathways.

The effects of active assist exercise on incoordination and free-reaching movements were less consistent.

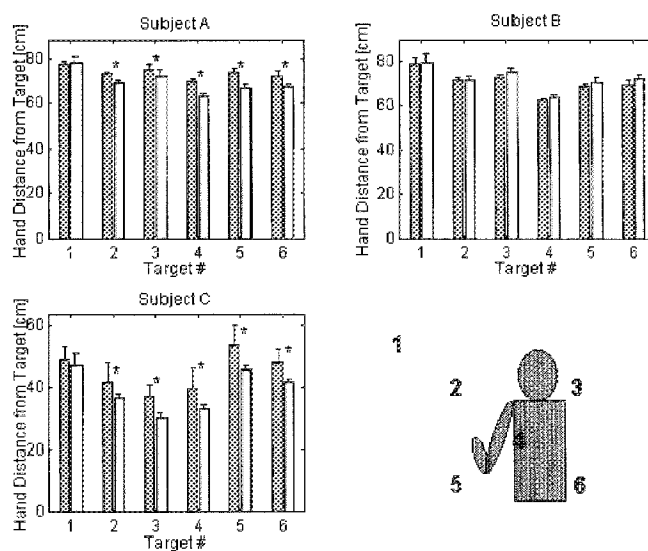

Figure 8.

Changes in unassisted, unconstrained range of motion expressed as minimum distance from the hand to the target during a reach (mean+SD). A smaller distance represents the subject's hand coming closer to the target. Darker bars are for pre-training evaluations. The table in the upper left describes the target locations on a semicircular screen with a 36-inch radius centered on the shoulder. Heights in the right column are target distances above (+) and below (-) the center of the shoulder. Subjects A and C showed significant improvements in range of motion reaching to five of the six targets as shown by the asterisks (t-test, $p < 0.01$). Subject B did not demonstrate any improvement in free-reaching range of motion.

Incoordination, quantified as off-axis force magnitude, only decreased with training for Subject A. The increase for Subject B may be attributable to the fact that this subject had minimal movement ability at the onset of training. She thus may have learned during training to grossly coactivate muscles "within synergy" in order to achieve at least some movement, while Subject A was able to refine control over a pre-existing movement capability.

Similarly, the lack of improvement in free reaching for Subject B may be attributable to this subject's low level of motor ability. That is, she may have been too weak to move effectively in the unsupported (free-reaching) condition, even though she regained some movement ability during supported arm movement along the ARM Guide. The fact that Subject A trained for eight weeks *versus* only four weeks for Subject B may also have contributed to Subject B's lack of improvement in free reaching.

The decreased variability of free range of motion seen in Subject C suggests that active assist training can improve free-movement consistency, as well as free-movement range. The two features may in fact be interrelated (21).

DISCUSSION AND CONCLUSIONS

This paper presents several assessment techniques developed with the ARM Guide, and initial therapeutic results. The assessment techniques provide a basis for evaluation of movement impairment and severity, and tracking of natural history and response to various treatments. The therapy results demonstrate that active assist therapy provided by the ARM Guide can produce quantifiable benefits in the chronic hemiparetic arm.

We are currently applying both the diagnostic and therapeutic techniques to a greater number of subjects. A key diagnostic question of interest is how the relative roles of impairments vary with lesion location and natural history. Also, movement after brain injury is disturbed in other ways not captured by the presented assessment techniques, such as decreased smoothness (22,23) and increased variability (24). An important goal is to incorporate techniques for assessing these and other disturbances into rehabilitator designs (e.g., 23).

In terms of the therapeutic application of rehabilitators, we believe that there are three key questions for future research that will determine their ultimate pattern of use. First, the effects of rehabilitator therapy reported so far, both in this and others studies (25,26), are small and arguably functionally insignificant. For example, the two severely impaired subjects at least doubled their range of movement along the ARM Guide with training, but the absolute magnitude of this improvement was less than 5 cm, and only a small amount of benefit transferred to free reaching (i.e., only a few cm, and not to an untrained movement direction). Still, small improvements may be important to subjects. For example, Subject A in this study was enthusiastic about the improvements, commenting on the increased comfort from reduced tone and the improved ability to use her impaired arm in a stabilizing role. Clearly, however, the ultimate goal is a return to normal or at least functional movement.

Can the efficacy of rehabilitator therapy be improved? Early intervention and increased therapy dosage (27) may help, but there probably exist fundamental limits to recovery when key motor outflow pathways are destroyed. A possible approach is to couple pharmacological or cell-replacement neuroregeneration approaches with rehabilitator therapy. The two approaches may work synergistically, with neuroregenerative treatments enhancing the capacity for adaptation, and rehabilitators providing the sensory motor activity to shape adaptation.

The second line of questioning is: What is the optimal therapy technique, and is a rehabilitator necessary to imple-

ment it? For the results presented here, the motorized assistance provided by the ARM Guide likely caused the reduction in tone, but was the motor needed to improve the ability to activate muscles? Would repetitive-movement practice in free space also allow subjects to make more reliable, faster, larger movements? Recent research demonstrating both neural reorganization and functional benefits of rehabilitative training in humans and in animal models has used essentially "hands-off" training techniques, in which repetitive movement by the patient or animal without manual assistance is the core intervention (28-30). Thus, the question of whether active assist therapy can enhance cortical reorganization, besides inducing peripheral changes to soft tissue, remains unanswered. It is possible to construct theoretical arguments in support of both negative and positive answers to this question. For example, many hypothesized motor learning strategies base their adaptation on a sensed kinematic error signal (e.g., 31). Active assist therapy reduces the kinematic error associated with a movement, and thus could slow or even render impossible the learning of altered neuro-mechanical dynamics. On the other hand, active assist therapy could also provide novel sensory stimulation by replicating kinematic features of desired movements, and thereby stimulate reorganization in neural systems structures that code those features. Ultimately, active assist therapy may be more applicable to locomotion rehabilitation (32-34), as locomotion circuits seem to rely more heavily on proprioceptive and cutaneous input in order to shape motor output (35).

The third question for future research regards practicality: Can rehabilitator technology be made viable for clinical and home use? There is a clear economic incentive to increasing therapy dosage without requiring increased therapist time. However, can therapy dosage be increased safely and reliably without supervision? Also, can large rehabilitators be manufactured cheaply enough to justify their benefits? The ARM Guide captures the core functionality required for active assistance therapy of reaching, with reduced device complexity. Another solution may be to use commercially available force-feedback gaming technology coupled with the networking power of the Internet to make rehabilitators that are small, cheap, safe, and widely accessible (36).

REFERENCES

1. Gresham GE, Duncan PW, Stason WB. Post-stroke rehabilitation. Rockville, MD: U.S. Department of Health and Human Services, Agency for Health Care Policy and Research, 1995. AHCPR

- Publication No. 95-0662.
2. Parker VM, Wade DT, Langton Hewer R. Loss of arm function after stroke: measurement, frequency, and recovery. *Int Rehabil Med* 1986;8(2):69-73.
 3. Krebs HI, Hogan N, Aisen ML, Volpe BT. Robot-aided neurorehabilitation. *IEEE Trans Rehabil Eng* 1998;6(1):75-87.
 4. Lum PS, Burgar CG, Kenney D, Van der Loos HFM. Quantification of force abnormalities during passive and active-assisted upper-limb reaching movements in post-stroke hemiparesis. *IEEE Trans Biomed Eng* 1999;46(6):652-62.
 5. Reinkensmeyer DJ, Hogan N, Krebs HI, Lehman SL, Lum PS. Rehabilitators, robots, and guides: new tools for neurological rehabilitation. In: Winters J, Crago P, editors. *Biomechanics and neural control of movement and posture*. Springer-Verlag; 2000. p. 516-533.
 6. Reinkensmeyer DJ, Dewald JPA, Rymer WZ. Robotic devices for physical rehabilitation of stroke patients: Fundamental requirements, target therapeutic techniques, and preliminary designs. *Technology and Disability* 1996;5:205-15.
 7. Reinkensmeyer DJ, Dewald JPA, Rymer WZ. Guidance based quantification of arm impairment following brain injury: A pilot study. *IEEE Trans Rehabil Eng* 1999;7(1):1-11.
 8. Reinkensmeyer DJ, Schmit BD, Rymer WZ. Assessment of active and passive restraint during guided reaching after chronic brain injury. *Ann Biomed Eng* 1999;27:805-14.
 9. Given JD, Dewald JPA, Rymer WZ. Joint dependent passive stiffness in paretic and contralateral limbs of spastic patients with hemiparetic stroke. *J Neurol Neurosurg Psychiatry* 1995;59:271-9.
 10. Goldspink G, Williams PE. Muscle fibre and connective tissue changes associated with use and disuse. In: Ada L, Canning C, editors. *Foundations for practice: topics in neurological physiotherapy*. London: Heinemann; 1990. p. 197-218.
 11. Corcos DM, Gottlieb GL, Penn RD, Myklebust B, Agarwal GC. Movement deficits caused by hyperexcitable stretch reflexes in spastic humans. *Brain* 1986;109:1043-58.
 12. McLellan DL. Co-contraction and stretch reflexes in spasticity during treatment with baclofen. *J Neurol Neurosurg Psychiatry* 1977;40:30-8.
 13. Brunnstrom S. *Movement therapy in hemiplegia*. New York: Harper and Row; 1970.
 14. Fellows SJ, Kaus C, Ross HF, Thilmann AF. Agonist and antagonist EMG activation during isometric torque development at the elbow in spastic hemiparesis. *Electroencephalogr Clin Neurophysiol* 1994;93:106-12.
 15. Fellows SJ, Kaus C, Thilmann AF. Voluntary movement at the elbow in spastic hemiparesis. *Ann Neurol* 1994;36(3):397-407.
 16. Reinkensmeyer DJ, Schmit BD, Rymer WZ. Can robots improve arm movement recovery after chronic brain injury? A rationale for their use based on experimentally identified motor impairments. *Proceedings of the Sixth International Conference on Rehabilitation Robotics*; 1999; p. 9-15.
 17. Reinkensmeyer DJ, Takahashi CD, Timoszyk WK, Reinkensmeyer AN, Kahn LE. Design of robot assistance for arm movement therapy following stroke. *Adv Robotics* 2000; *in press*.
 18. Lum PS, Lehman SL, Reinkensmeyer DJ. The bimanual lifting rehabilitator: A device for rehabilitating bimanual control in stroke patients. *IEEE Trans Rehabil Eng* 1995;3(2):166-74.
 19. Gruener G. Control of time critical robotic rehabilitation. *Proceedings of the 1st Joint BMES/EMBS Meeting*; 1999.
 20. Gowland C, Stratford P, Ward M, Moreland J, Torresin W, Van Hullenaar S, et al. Measuring physical impairment and disability with the Chedoke-McMaster Stroke Assessment. *Stroke* 1993;24(1):58-63.
 21. Harris CM, Wolpert DM. Signal-dependent noise determines motor planning. *Nature* 1998;394:780-4.
 22. Trombly CA. Deficits of reaching in subjects with left hemiparesis: A pilot study. *Am J Occup Ther* 1992;46(10):887-97.
 23. Krebs HI, Aisen ML, Volpe BT, Hogan N. Quantization of continuous arm movements in humans with brain injury. *Proc Natl Acad Sci USA* 1999;96:4645-9.
 24. Levin MF. Interjoint coordination during pointing movements is disrupted in spastic hemiparesis. *Brain* 1996;119:281-93.
 25. Aisen ML, Krebs HI, Hogan N, McDowell F, Volpe BT. The effect of robot-assisted therapy and rehabilitative training on motor recovery following stroke. *Arch Neurol* 1997;54:443-5.
 26. Lum PS, Van der Loos HFM, Shor P, Burgar CG. A robotic system for upper-limb exercises to promote recovery of motor function following stroke. *Proceedings Sixth International Conference on Rehabilitation Robotics*; 1999; p. 235-9.
 27. Sunderland A, Tinson DJ, Bradley EL, Fletcher D, Langton Hewer R, Wade DT. Enhanced physical therapy improves recovery of arm function after stroke. A randomized controlled trial. *J Neurol Neurosurg Psychiatry* 1992;55:530-5.
 28. Liepert J, Bauder H, Miltner W, Taub E, Weiller C. Treatment-induced cortical reorganization after stroke in humans. *Stroke* 2000;31(6):1210-6.
 29. Nudo RJ, Wise BM, SiFuentes F, Milliken GW. Neural substrates for the effects of rehabilitative training on motor recovery after ischemic infarct. *Science* 1996;272:1791-4.
 30. Jones TA, Chu CJ, Grande LA, Gregory AD. Motor skills training enhances lesion-induced structural plasticity in the motor cortex of adult rats. *J Neurosci* 1999;19(22):10153-63.
 31. Scheidt RA, Reinkensmeyer DJ, Condit MA, Rymer WZ, Mussa-Ivaldi FA. Persistence of motor adaptation during constrained, multi-joint arm movements. *J Neurophysiol* 2000;84:853-62.
 32. Uhlenbrock D, Sarkodie-Gyan T, Reiter F, Konrad M, Hesse S. Development of a servo-controlled gait trainer for the rehabilitation of non-ambulatory patients. *Biomedizinische Technik* 1997;42:196-202.
 33. Bejczy A. Towards development of robotic aid for rehabilitation of locomotion-impaired subjects. *Proceedings of IEEE Workshop on Robot Motion and Control*; 1999; Kiekrz, Poland. p. 9-16.
 34. Reinkensmeyer DJ, Timoszyk WK, de Leon RD, Joynes R, Kwak E, Minakata K, Edgerton VR. A robotic stepper for retraining locomotion in spinal-injured rodents. *Proceedings IEEE International Conference on Robotics and Automation*; 2000; San Francisco, California. p. 2889-94.
 35. KG, Misiaszek JE, Fouad K. Enhancement and resetting of locomotor activity by muscle afferents. *Ann NY Acad Sci* 1998;860:203-15.
 36. Reinkensmeyer D, Painter C, Yang S, Abbey E, Kaino B. An Internet-based, force-feedback rehabilitation system for arm movement after brain injury. *Proceedings of CSUN's 15th Annual International Conference, "Technology and Persons with Disabilities,"* March 20-25, 2000, Los Angeles, CA; <http://www.csun.edu/cod/conf2000/proceedings/0080Reinkensmeyer.html>.