

Lawrence Berkeley National Laboratory

Recent Work

Title

DIGITAL NEUTRON RADIOGRAPHY USING PLANE CONVERTERS WITH MULTIWIRE PROPORTIONAL CHAMBERS

Permalink

<https://escholarship.org/uc/item/64w181pt>

Author

Kaplan, S.N.

Publication Date

1981-12-01



Lawrence Berkeley Laboratory

UNIVERSITY OF CALIFORNIA

RECEIVED
LAWRENCE
BERKELEY LABORATORY
AUG 18 1982
LIBRARY AND
DOCUMENTS SECTION

Physics, Computer Science & Mathematics Division

Presented at the First World Conference on Neutron Radiography, San Diego, CA, December 7-10, 1981

DIGITAL NEUTRON RADIOGRAPHY USING PLANE CONVERTERS WITH MULTIWIRE PROPORTIONAL CHAMBERS

Selig N. Kaplan, Bruce A. Director,
Victor Perez-Mendez, and Kenneth H. Valentine

December 1981

TWO-WEEK LOAN COPY

This is a Library Circulating Copy which may be borrowed for two weeks. For a personal retention copy, call Tech. Info. Division, Ext. 6782.

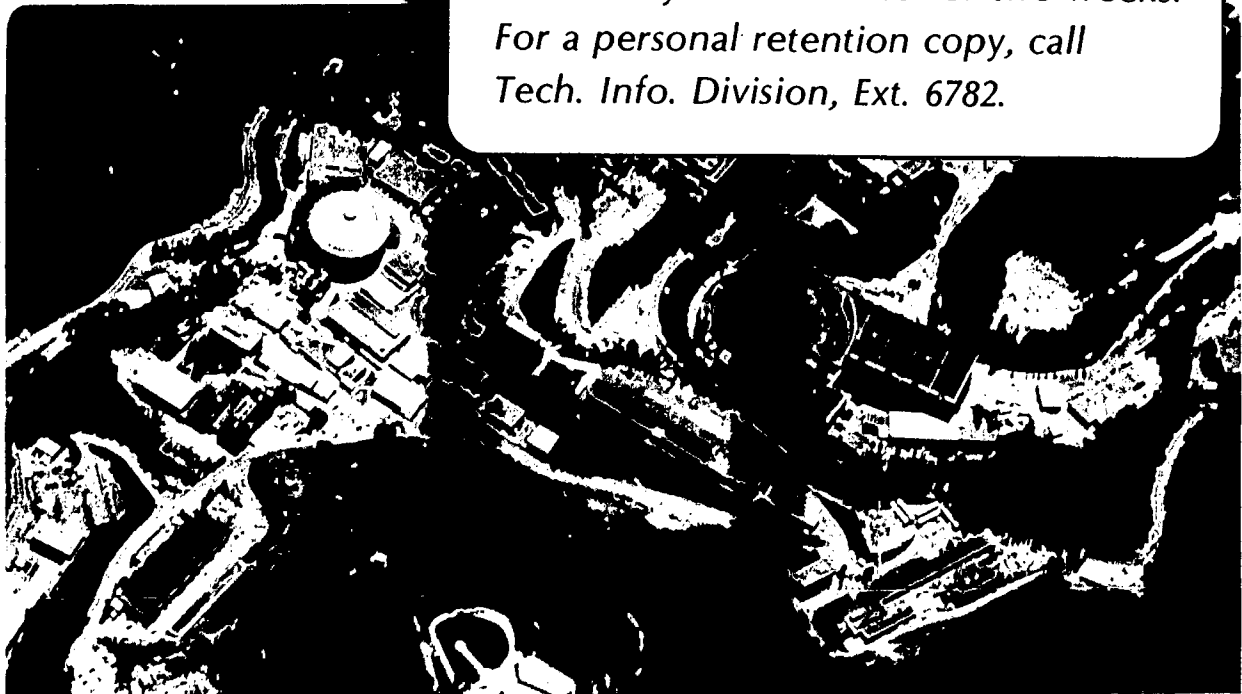

LBL-14714
c-2

DISCLAIMER

This document was prepared as an account of work sponsored by the United States Government. While this document is believed to contain correct information, neither the United States Government nor any agency thereof, nor the Regents of the University of California, nor any of their employees, makes any warranty, express or implied, or assumes any legal responsibility for the accuracy, completeness, or usefulness of any information, apparatus, product, or process disclosed, or represents that its use would not infringe privately owned rights. Reference herein to any specific commercial product, process, or service by its trade name, trademark, manufacturer, or otherwise, does not necessarily constitute or imply its endorsement, recommendation, or favoring by the United States Government or any agency thereof, or the Regents of the University of California. The views and opinions of authors expressed herein do not necessarily state or reflect those of the United States Government or any agency thereof or the Regents of the University of California.

DIGITAL NEUTRON RADIOGRAPHY USING PLANE CONVERTERS WITH MULTIWIRE PROPORTIONAL CHAMBERS

Selig N. Kaplan, Bruce A. Director, Victor Perez-Mendez,
Kenneth H. Valentine⁺,
University of California Berkeley, CA and Lawrence Berkeley Laboratory
University of California, Berkeley, CA 94720

INTRODUCTION

The work described here was completed more than three years ago, and represents, in large part the PhD¹⁾ and MS²⁾ thesis research of two of the present authors. Much of it has been reported previously elsewhere^{3,4)}. It constitutes an effort to develop and study a moderately low cost, moderate resolution, high sensitivity, on-line method for digital neutron radiography, intended for use where neutron fluence was limited by source strength, or received dose. The basic imaging system consisted of a position-sensitive gas proportional chamber together with its associated imaging electronics, and a plane neutron converter. Enriched-boron, gadolinium, and polyethylene (for fast neutrons) converters were analyzed and tested. Some work was done on digital data enhancement, and efforts to improve spatial resolution included pressurizing the proportional-chamber gas to reduce the track lengths of the neutron-interaction products.

The results of this work are described below.

THE DETECTION SYSTEM

Multiwire Proportional Chamber

The multiwire proportional chamber (MWPC) consisted of three parallel wire planes, a central (anode) plane, and two outer (cathode) planes. Each plane was a parallel-wire grid mounted on a glass epoxy frame. The anode wires were 12.5- μ meter gold-plated tungsten and were spaced 1.5-mm apart. The cathode wires were made from 37- μ meter gold-plated molybdenum and were spaced 1-mm apart. The wires axes in the two cathode planes were mutually perpendicular. Interplane spacing was 3 mm, the cathodes being 6 mm apart. A converter plate can be mounted on either the front or back of the detector with its face supported 0.5 mm from the cathode plane. A schematic blowup of the detector assembly is shown in Figure 1. For most of the measurements described herein, only a back converter was used.

One side of each cathode plane was capacitively coupled to an electromagnetic delay line. Position information was derived by measuring the time delay between a prompt anode pulse and a delayed cathode pulse. The two cathodes, having their wire planes mutually perpendicular, permitted simultaneous position measurement along two orthogonal axes.

The detector had a sensitive area 25 cm x 25 cm, and maximum overall dimensions, when mounted in its pressure chamber, of 47 cm x 47 cm x 9 cm.

⁺ Present address

Oak Ridge National Laboratory, Oak Ridge, TE
This work was supported by the U.S. Department of Energy under Contract No. DE-AC03-76SF00098.

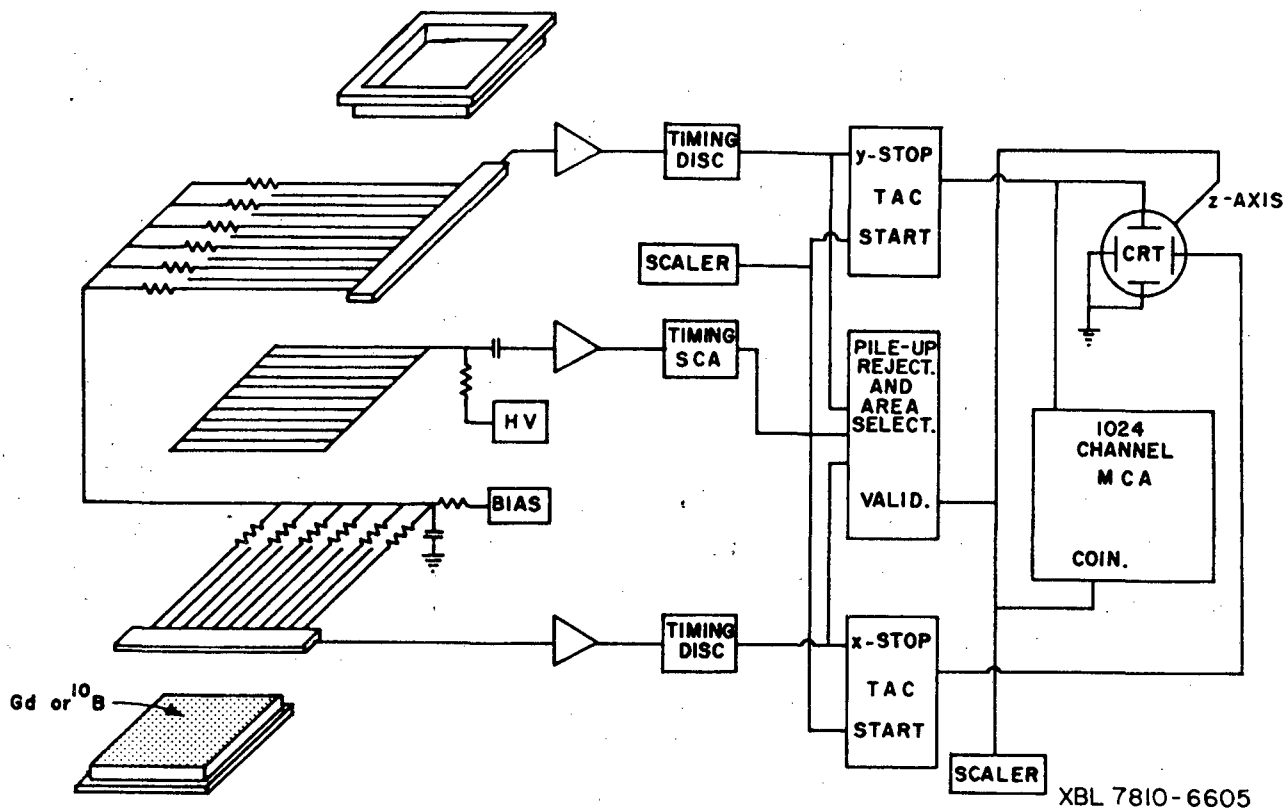

Fig. 1. Schematic diagram of wire chamber and electronics.

The Analysis System

The anode signal and the two cathode signals were processed through charge-sensitive preamplifiers and timing discriminators. The processed anode pulse then provided a "start" signal for two time-to-amplitude converters (TAC). Each processed cathode pulse provided one "stop" (Fig. 1). An analog image of an interaction (event) in the chamber is derived by placing the TAC outputs into the x-y inputs of an oscilloscope, and a timing, strobe, pulse into the z input. For each event, after sufficient time has elapsed for both TACs to reach their full amplitude ($2\mu\text{s}$), the strobe pulse intensifies a dot on the scope screen. Integration of the dot pattern, either by eye, or on film produces the analog image. Alternatively digital images can be accumulated, stored, and processed by using the same input electronics in conjunction with a two-dimensional analyzer. Figure 1 also shows a one-dimensional-analysis setup for resolution measurements. Figure 2 shows the experimental setup at the neutron beam port.

Neutron Converters

The neutron converters were mounted on a flat substrate of 0.15 cm-thick flat aluminum sheet stock, which was joined to a machined aluminum stiffening frame, either with epoxy, or by electron-beam welding. Both bonding methods produced an adequately flat surface.

The boron converter was made by covering the entire aluminum substrate with pressure-sensitive tape and then dusting 92%-enriched Boron-10 powder onto the resulting adhesive surface. The thickness of the boron layer made in this manner varied between 3 and 4 mg/cm. The gadolinium converter was made by epoxying a 75- μmeter Gd foil onto the substrate. A fast neutron

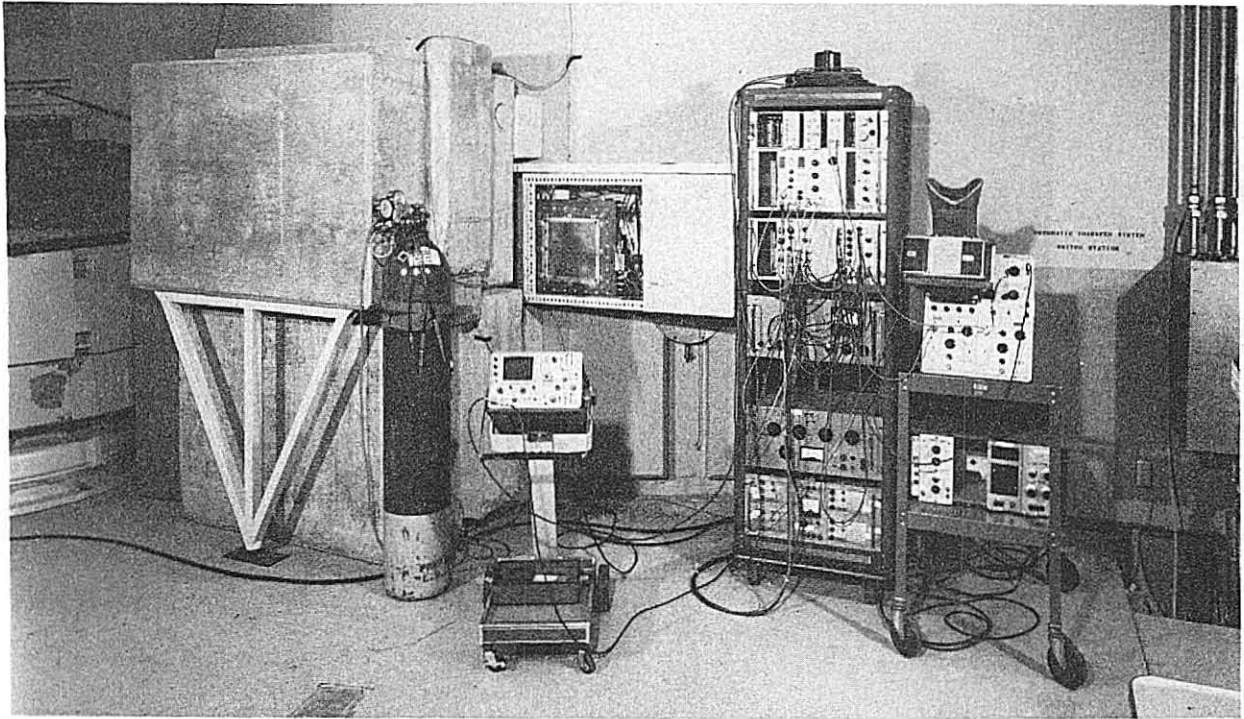

XBB 742-855

Fig. 2. Exposure facility at the Berkeley Research Reactor. The MWPC is shown mounted in the experiment holder.

converter was made by attaching a 1.5 mm sheet of polyethylene to the substrate with double-sided tape.

EFFICIENCY AND RESOLUTION

Design Considerations

Neutron reaction products will produce relatively long tracks in the low-density gas of the proportional chamber. For example the 70-keV electron from Gd, which has a range of only 50 μ meters in film emulsion, has a range of over 3 cm in proportional-chamber gas (primarily Ar) at STP. The alpha particle from neutron capture, on the other hand has a range of less than 1 cm in Ar. For this reason, although Gd was the converter of choice for photographic-emulsion work, B was our first choice. Figure 3 shows residual-range curves of alpha particles leaving the B converter. The curves were generated by dividing the converting layer onto 25 equal-thickness zones, and then calculating the locus of range end points as a function of emission angle. The numbers appearing on alternate curves are the percent of alphas originating in the zone, that energy. The alphas from all zones appear to emerge from the same point because on the scale of the figure the converter dimensions are negligibly small.

Circular segments on the graph define constant alpha-particle range and are therefore lines of constant energy, or energy deposition. The two segments shown correspond to 0.1 and 1 MeV. If signal-amplitude discrimination is employed, then only those alphas lying on the range curves between energy-defining segments will contribute to a radiographic image. Such energy discrimination can improve spatial resolution, but only at the expense of

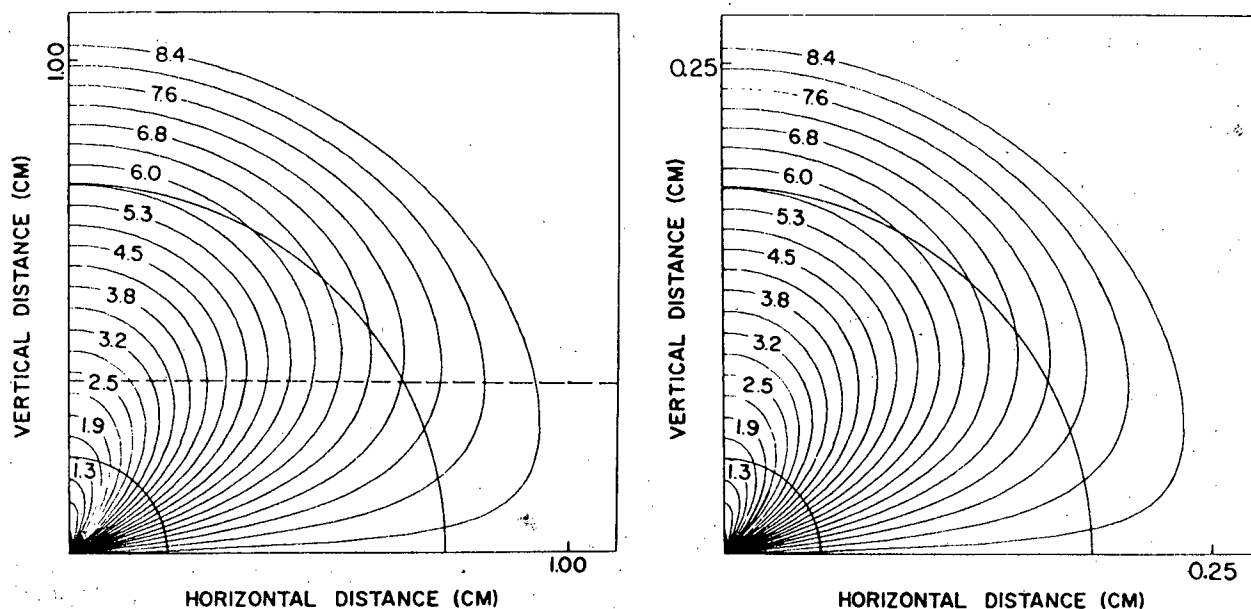

XBL7812-13340A

Fig. 3. Family of residual-range curves for α particles emerging from a ^{10}B converter into Ar a) at 1 atm and b) at 4 atm. (---- is anode)

neutron-detection efficiency.

Several other characteristics of the conversion process can be inferred from the figure. If the converter is thinner than the alpha range, then inner curves will disappear, one curve for each 1/25 of the range. Similarly, if the converter is coated with a thin layer of non-converting material, then outer curves will disappear, one for each 1/25 of the range. This latter effect will also improve resolution, but again at the expense of efficiency. Increasing the pressure of the chamber gas simply changes the abscissa and ordinate scales proportionately. To illustrate this effect, Figure 3b shows the residual range curves for alpha particles at 4 atm chamber pressure. At this pressure the maximum alpha range is less than 0.25 cm, improving resolution with no loss in efficiency. Figure 4 shows a comparison of residual-range curves for the 70-keV electron from Gd-157 at both 1 and 4 atm chamber pressure. Note that the family of curves for the electron at 4 atm appears similar to those for the alpha at 1 atm.

Figure 5 shows residual-range curves for 1-MeV neutrons from a polyethylene converter. Because n-p scattering occurs only in the forward direction, the polyethylene converter must be placed upstream of the chamber. The resolution limit in this case is not entirely determined by the proton range, but merely by that part of the proton track that lies in the chamber. Even for 1-MeV neutrons, most of the proton tracks extend well beyond the 6-mm thickness of the sensitive volume.

Calculated converter efficiencies for thermal neutrons were 15% and 6% respectively for the Gd and B. In both cases the measured values were only about 40% of those calculated. For the polyethylene converter an efficiency of 0.1% was calculated for a Pu-B neutron spectrum, very close to what was achieved experimentally.

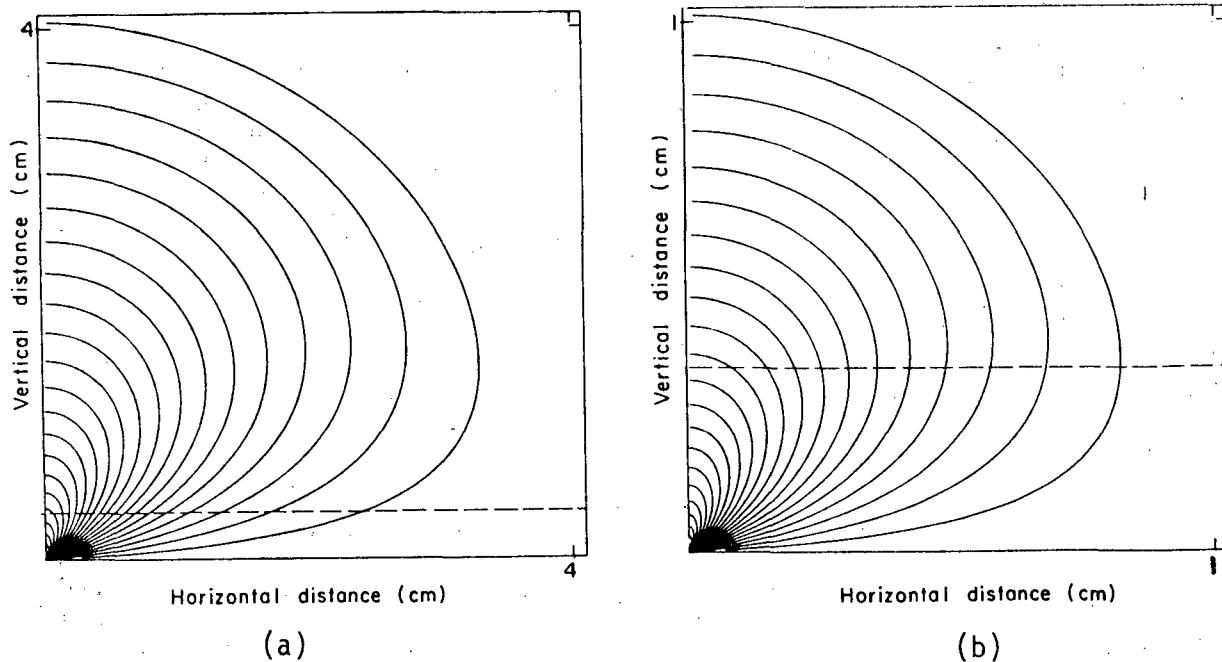

Fig. 4. Residual-range curves for 70-keV electrons emerging from a Gd converter into Ar gas a) at 1 atm and b) at 4 atm. (---- is anode)

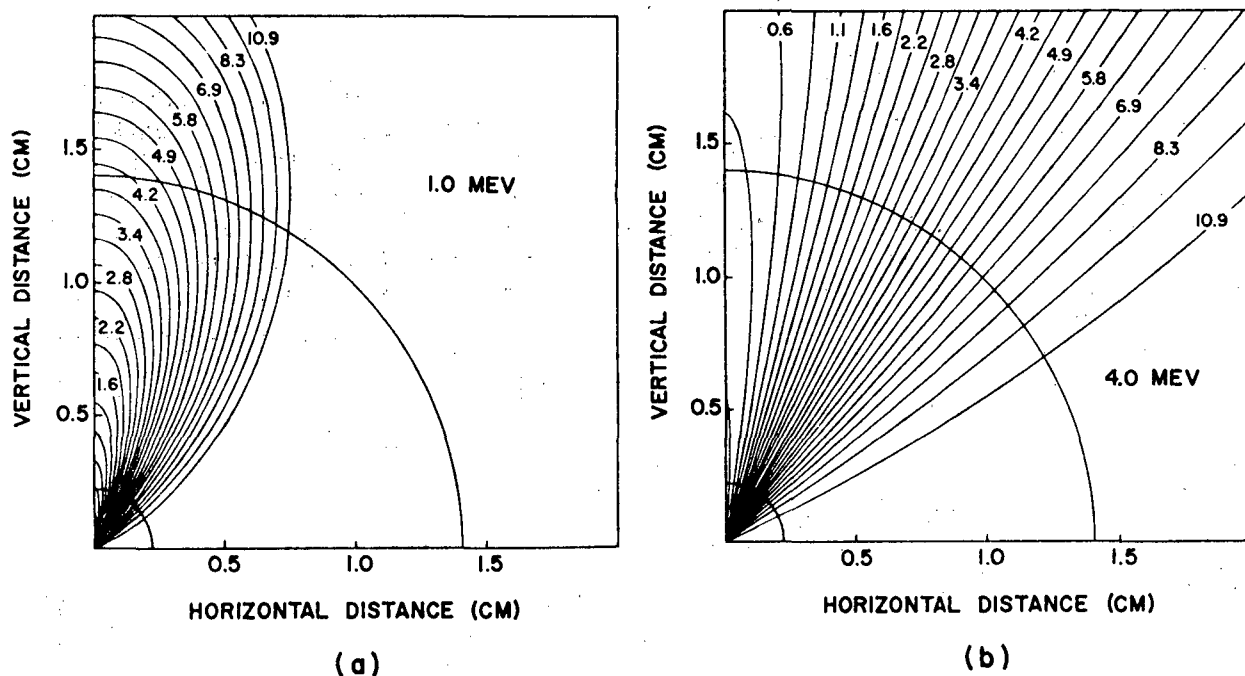

Fig. 5. Residual-range curves for recoil protons ejected from a CH_2 converter for a) 1 MeV neutrons and b) 4 MeV neutrons.

Measurements

Spatial resolution was determined by calculating modulation transfer functions (MTF) from digital images of Cd bar patterns. Some calculations of MTF's from single-slit images [Line Spread Functions (LSF)] were also made for comparison (Fig. 6).

Figures 7 and 8 show MTF's as a function of chamber pressure for Gd and B respectively. Figure 9 shows critical frequency (the spatial frequency at

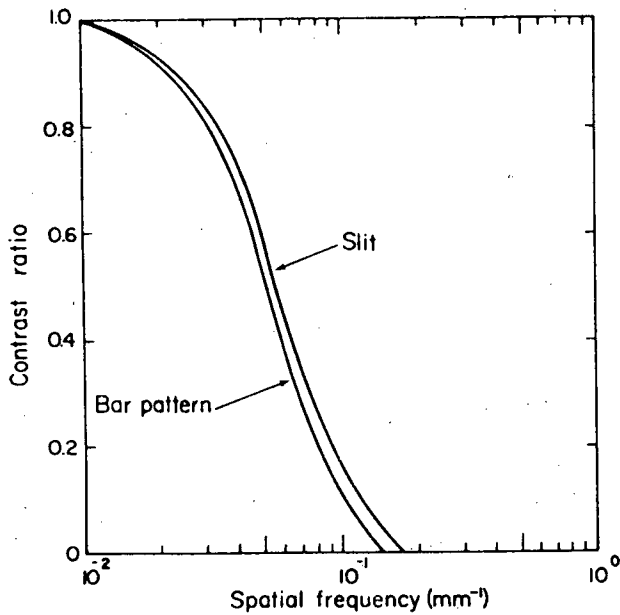

Fig. 6. Comparison of the modulation transfer function (MTF) as measured from a slit image and from a bar pattern image.

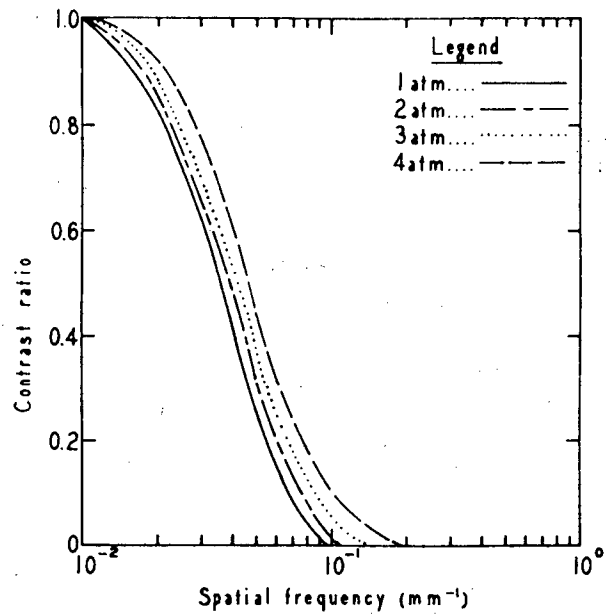

Fig. 7. MTF's using the Gd converter at 1, 2, 3, and 4 atm.

which the contrast ratio falls to $1/e$ as a function of chamber pressure. The B resolution improved significantly with pressure and reached a maximum value for ω_c of almost $3/\text{mm}$ at 4 atm, which was however less than the four-fold improvement that one might expect from simple scaling. On the other hand, for gadolinium converter there was little improvement in resolution. In both cases there was a 4-fold increase in the background counting rate, suggesting that increasing detector density does, at least, increase gamma background proportionately.

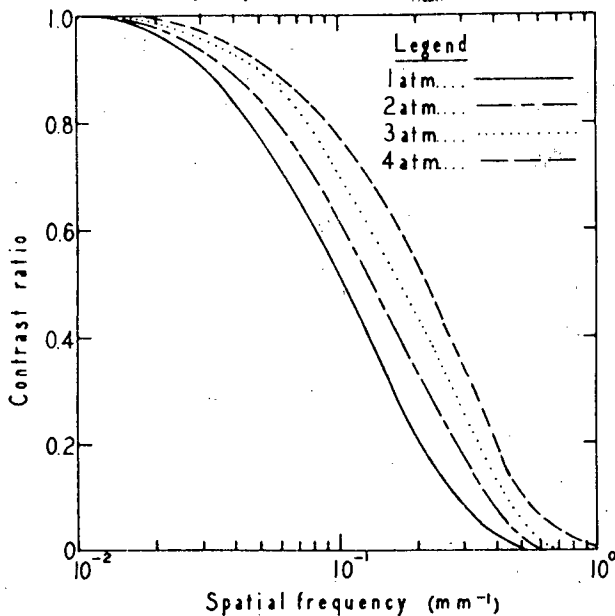

Fig. 8. MTF's using the ^{10}B converter at 1, 2, 3, and 4 atm.

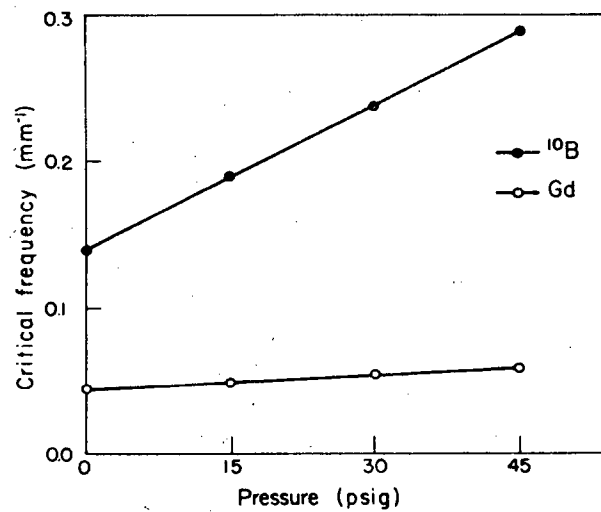

Fig. 9. Critical frequency, ω_c , as a function of pressure.

XBL 7810-6603

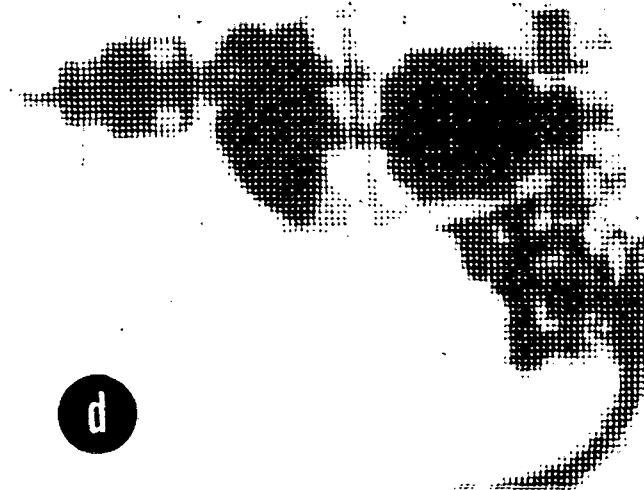
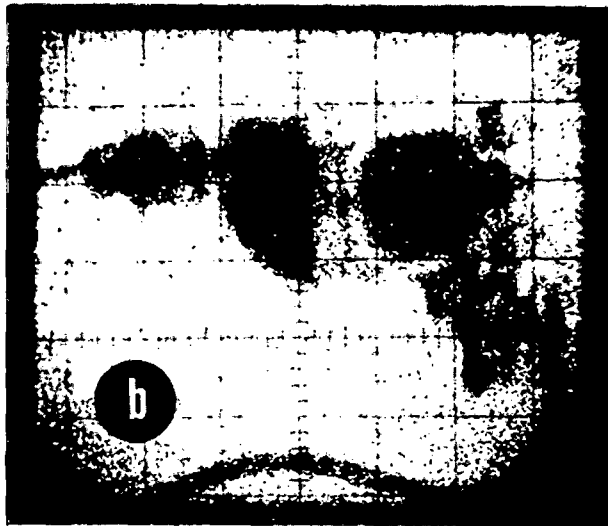
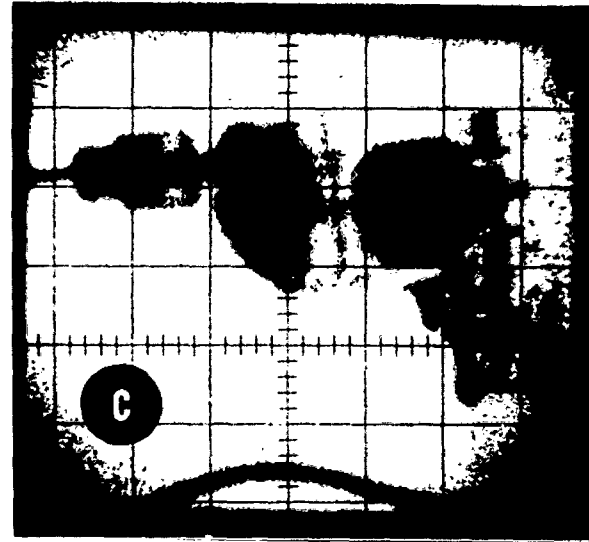
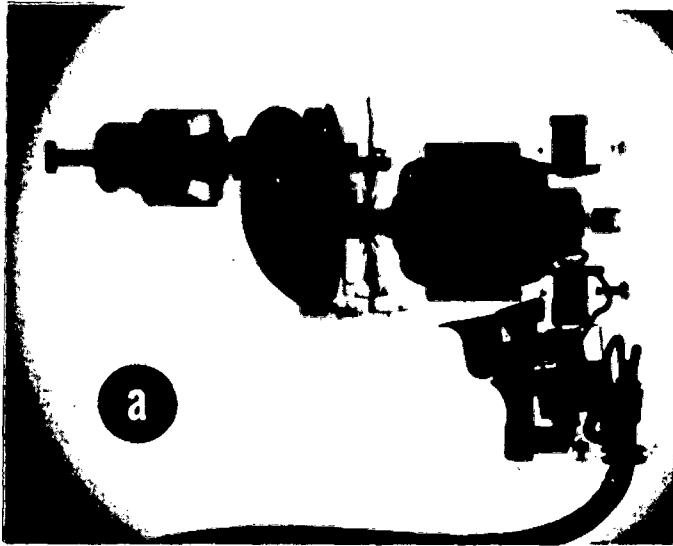

Fig. 10. Neutron Radiographic images of an electric drill on film using a GdO converter, a); as analog oscilloscope displays of neutron interaction densities of 5mm^{-2} , b); and 60mm^{-2} , c); and from a reconstruction of digitally stored and normalized data, d).
(XBB 758-6522)

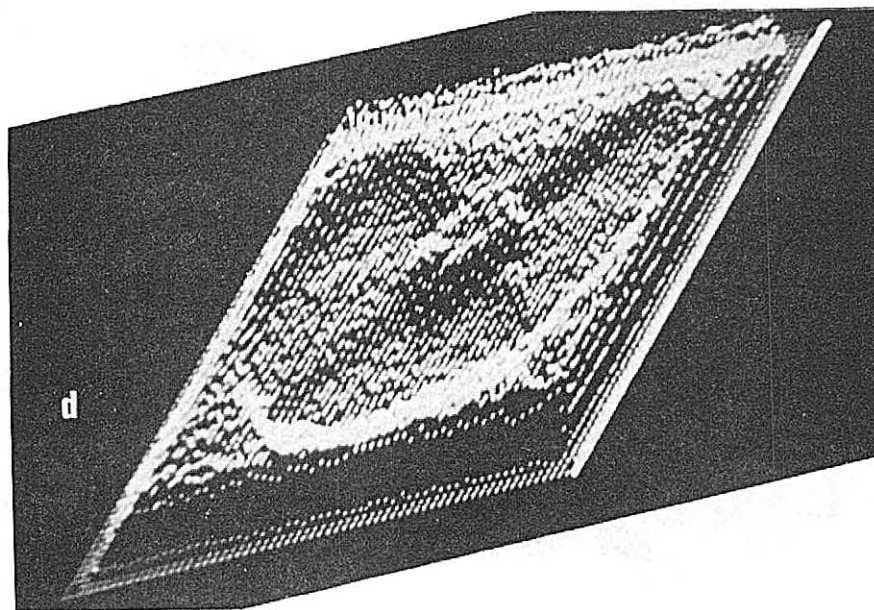
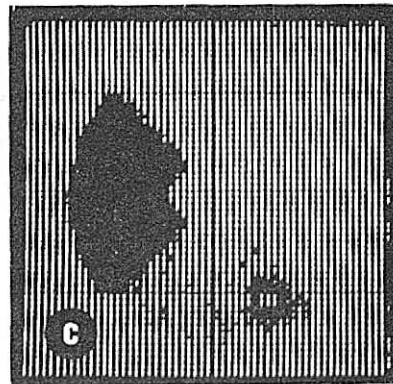
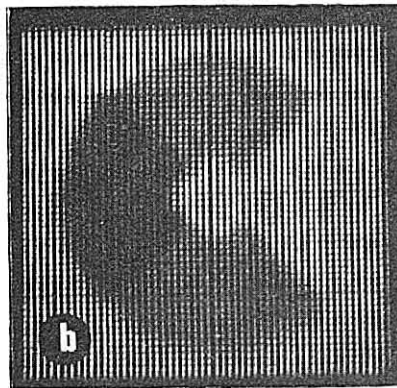
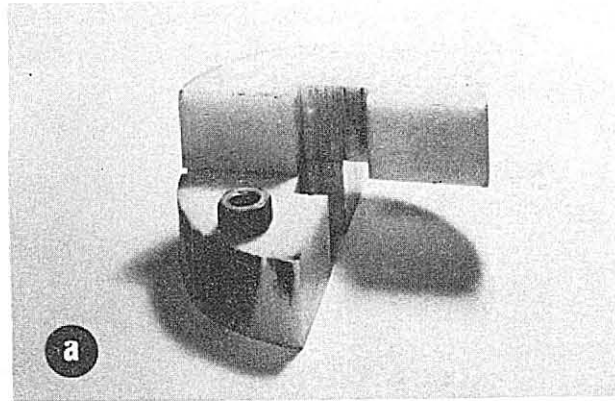

Fig. 11. a) Test object used for fast neutron imaging, b) and c) fast neutron digital radiographs of test object, d) isometric display of digital image. (XBB 742-870)

SOME EXAMPLE IMAGES AND CONCLUSIONS

Figure 10 shows a normal neutron radiograph of an electric drill (10a) together with polaroid photos of analog oscilloscope images (10b,c), and a digitally stored and reconstructed image (10d) of the same drill. While not a likely subject for digital processing, the drill has sufficient structural detail to illustrate the characteristics, including limitations, of this digital imaging system. The direct analog images were made in exposures of 7s and 85s respectively to a thermal-neutron beam of 10^4 n-cm⁻²-s⁻¹. The digital image was stored in a two-dimensional array of 2mm x 2mm-area elements, normalized, element-by-element against an object-out background image and then displayed in 32 shades of gray.

Figure 11 shows a test object for fast neutron imaging (11a), together with digital images made using a Pu-Be source and the polythylene converter (11b,c, and d). Various features are enhanced by digital discrimination.

At the time the above work was done we had no on-line computer available for such data processing. The now-standard computer functions were simulated using a two-dimensional 4096-channel pulse-height analyzer. Present technology and cost breakthroughs have probably made digital processing no more difficult nor expensive than analog oscilloscope imaging. So, where the quality of this resolution has application, it can be implemented at relatively modest cost.

REFERENCES

- [1] VALENTINE, K.H., "The Development of a Multiwire Proportional Chamber Imaging System for Neutron Radiography", (Thesis, 1974).
- [2] DIRECTOR, B.A., "Performance of a Pressurized Multiwire Proportional Chamber for Neutron Imaging", (Thesis, 1978).
- [3] VALENTINE, K., KAPLAN, S., KAUFMAN, L., and PEREZ-MENDEZ, V., IEEE Trans. on Nuc. Sci. NS-21, 178 (Feb. 1974).
- [4] DIRECTOR, B.A., KAPLAN, S., and PEREZ-MENDEZ, V., IEEE Trans. on Nuc. Sci. NS-25, 558 (Feb. 1978).

This report was done with support from the Department of Energy. Any conclusions or opinions expressed in this report represent solely those of the author(s) and not necessarily those of The Regents of the University of California, the Lawrence Berkeley Laboratory or the Department of Energy.

Reference to a company or product name does not imply approval or recommendation of the product by the University of California or the U.S. Department of Energy to the exclusion of others that may be suitable.

TECHNICAL INFORMATION DEPARTMENT
LAWRENCE BERKELEY LABORATORY
UNIVERSITY OF CALIFORNIA
BERKELEY, CALIFORNIA 94720