

UC Berkeley
Dissertations, Department of Linguistics

Title

Morphological Sources of Phonological Length

Permalink

<https://escholarship.org/uc/item/64b9t7p2>

Author

Pycha, Anne

Publication Date

2008

Morphological Sources of Phonological Length

by

Anne Pycha

B.A. (Brown University) 1993

M.A. (University of California, Berkeley) 2004

A dissertation submitted in partial satisfaction of the

requirements for the degree of

Doctor of Philosophy

in

Linguistics

in the

Graduate Division

of the

University of California, Berkeley

Committee in charge:

Professor Sharon Inkelas (chair)

Professor Larry Hyman

Professor Keith Johnson

Professor Johanna Nichols

Spring 2008

Abstract

Morphological Sources of Phonological Length

by

Anne Pycha

Doctor of Philosophy in Linguistics

University of California, Berkeley

Professor Sharon Inkelas, Chair

This study presents and defends Resizing Theory, whose claim is that the overall size of a morpheme can serve as a basic unit of analysis for phonological alternations. Morphemes can increase their size by any number of strategies -- epenthesizing new segments, for example, or devoicing an existing segment (and thereby increasing its phonetic duration) -- but it is the fact of an increase, and not the particular strategy used to implement it, which is linguistically significant. Resizing Theory has some overlap with theories of fortition and lenition, but differs in that it uses the independently-verifiable parameter of size in place of an ad-hoc concept of “strength” and thereby encompasses a much greater range of phonological alternations. The theory makes three major predictions, each of which is supported with cross-linguistic evidence. First, seemingly disparate phonological alternations can achieve identical morphological effects, but only if they trigger the same direction of change in a morpheme’s size. Second, morpheme interactions can take complete control over phonological outputs, determining surface outputs when traditional features and segments fail to do so. Third and finally, null morpheme realizations are not special cases warranting special analyses, but instead

exist along a cline with partial and full morpheme realizations. By integrating well-established facts about phonetic duration directly into the abstract unit of morpheme size, this study solves several outstanding problems that traditional phonological constituents cannot handle, and makes a contribution to the literature on both the phonetics-phonology and phonology-morphology interfaces.

Table of contents

Acknowledgments	iv
Chapter 1: Introduction	1
1.1 Overview of chapters	10
1.2 Overview of introduction	11
2.0 Formalisms and working example: Päre	11
2.1 Contact relationships	13
2.2 Relative size scales	14
2.3 Formalisms and working example: Finnish	19
2.4 Alternative explanations for the Päre and Finnish patterns	20
2.5 Resizing Theory and Optimality Theory	21
3. Phonetic evidence for consonant length	22
3.1 Raw phonetic duration	23
3.2 Duration ratios	25
3.3 Phonetic facts and higher-level patterns	27
3.4 Where are timing units?	29
3.4.1 Gemimates versus consonant clusters	30
3.4.2 Syllabification of gemimates	31
3.4.3 Total assimilation	36
4. Situating the scales of Resizing Theory	40
4.1 Size of scalar items	40
4.2 Substantiveness of scales	42
4.3 The link between scales and contact	43
5. Fortition and lenition	45
6. Situating the contact relationships of Resizing Theory	47
Chapter 2: Phonological alternations in the service of higher effects	
1. Introduction	49
2. Downsizing in Turkish	51
2.1 Basic analysis of Turkish	54
2.2 Nature and scope of the Turkish patterns	59
2.2.1 Turkish voicing	60
2.2.2 Turkish velar deletion	64
2.3 Proposal of Inkelas & Orgun (1995)	68
2.4 Re-thinking the intervocalic constraint	70
2.5 Rethinking phonologically epenthetic vowels	72
2.6 Rethinking suffix-initial velars	73
2.7 Other root-final segments	73
2.7 Limitations of Resizing Theory analysis	75
3. Upsizing in Northern Sotho	76
3.1 Overview of the Northern Sotho pattern	77
3.2 Basic analysis of Northern Sotho	79
3.3 Northern Sotho velar epenthesis	81
3.4 Previous analyses of the Sotho languages	83

3.4.1 Historical analyses	83
3.4.2 Previous synchronic analysis	85
3.5 Importance of Northern Sotho for evaluating articulation-based theories	87
4. Upsizing in Hungarian	88
4.1 Overview of the Hungarian pattern	89
4.2 Basic analysis of Hungarian	90
4.3 Supporting evidence for epenthesis	91
5. Upsizing in LuGanda and Choctaw	95
6. Compensatory Resizing	99
6.1 Meithei compensatory downsizing	100
6.2 Compensatory downsizing in Ibibio	102
7. A cline of contact relationships in T ^h ese	104
7.1 Plosive-initial roots	107
7.2 Liquid-initial and nasal-initial roots	110
7.3 Limitations	112
8. Conclusion	115
Chapter 3: Taking some phonology out of morpho-phonology	
1. Introduction	116
2. Degrees of upsizing in Pări	118
2.1 Overview of Pări	121
2.2 Starting points: Grades 1 and 6	122
2.3 Voicing and velar deletion: Grades 2.0 and 2.1	123
2.4 Nasal-stop clusters: Grades 3.0 and 3.1	126
2.5 Nasal-stop clusters: Grade 5	128
2.6 Nasal geminates: Grades 4.0 and 4.1	131
2.6.1 Feature-based analysis of Grades 4.0 and 4.1	134
2.6.2 Resizing Theory analysis of Grades 4.0 and 4.1	135
2.6.3 Motivation for upsizing via nasalization	139
2.6.4 Scales and inventory constraints	142
2.7 Summary	144
2.8 Remaining issue	145
3. Upsizing and (non)-upsizing in Western Shoshoni	146
3.1 Overview of Western Shoshoni	147
3.2 Traditional approach to morphologically-conditioned gemination	151
3.3 Resizing Theory of Western Shoshoni	152
3.4 Extending the analysis to other morpheme types	154
3.5 Alternative analysis using co-phonologies	160
4. Divergent upsizing in Hungarian	161
4.1 Overview of Hungarian	163
4.2 Traditional analysis of Hungarian	165
4.3 Resizing Theory analysis of Hungarian	167
4.4 General contact relationships: Roots and rightmost elements	169

5. Conclusion	174
Chapter 4: Bringing null allomorphs back into the fold	
1. Introduction	175
2. Previous theoretical treatments of blocking	176
3. Scales in Hupa	182
3.1 Overview of Hupa	183
3.2 Null allomorphy (total blocking)	184
3.3 Partial allomorphy (partial blocking)	187
3.4 Resizing Theory analysis	191
3.5 Other size scales in Hupa	194
3.6 Transitivity of contact relationships	196
3.7 Interim summary	198
4. Kanuri	198
4.1 Segmental correlates of the Auxiliary morpheme	200
4.2 Tonal correlates of the Auxiliary morpheme	202
4.3 Partial blocking in Kanuri	206
4.4 Total blocking in Kanuri	208
4.5 Analysis of Kanuri	210
4.6 Interim summary	210
5. Partial blocking in Koasati and West Greenlandic	211
6. Concluding remarks	214
Chapter 5: Beyond length and beyond morphemes	
1. Introduction	216
2. Phonological alternations in the service of higher effects	217
2.1 Downsizing in Dananshan Hmong	217
2.2 Downsizing in Eastern A-Hmao	220
2.3 Downsizing in Makaa	223
2.4 Upsizing in Krachi	226
3. Taking some phonology out	228
3.1 Phonology as we know it: Downdrift and downstep triggered by L	228
3.2 <i>Not</i> phonology as we know it: Downdrift triggered by H	230
4. Clines	231
5. Conclusion	234

Acknowledgments

A large cast of characters supported me during the lengthy process of obtaining a doctoral degree. The largest cast is also the least tangible, namely the taxpayers of California and the tuition-paying students at the University of California, Berkeley. They probably do not know it, but they have fed me and clothed me, however modestly, during the past five years. In other words, a Chicagoan showed up on the west coast and received an education *for free* -- it is a privilege that I have tried to take seriously, and I hope one day that I will be able to return to California and give back some of what it has offered to me. I also received financial support from Phi Beta Kappa and the Abigail Hodgen Publication Fund, and I extend my utmost appreciation to their donors.

On the very tangible side of things, my advisor Sharon Inkelas has been a rock of professional support and personal friendship. It is true that I cannot keep up with her: she has offered many thorough critiques of my work over the years, and I feel proud to have understood approximately half of what she said. Sharon has the talent of envisioning the life of an idea far beyond its birthplace; she sees the chessboard dozens of moves into the future. I thank her wholeheartedly for giving my work as much attention as she did, even when the end product fell short of her chessboard vision.

Larry Hyman provided detailed comments on the dissertation which helped me to improve it a great deal. Keith Johnson provided expert guidance on several of the projects that I undertook during my graduate career. He always had something interesting to say, which kept me thinking; and he always had something encouraging to say, which

sustained me during difficult times. Johanna Nichols gave valued feedback as the outside reader, and was a pleasure to work with.

Outside of my committee, faculty members Andrew Garrett, Line Mikkelsen, and Lynn Nichols have been sources of motivation and support. I am also grateful to Belen Flores, who kindly and expertly guided me and many other students through the maze of graduate school requirements. My fellow cohort members Gabriella Caballero, Christian DiCanio, Marc Ettliger, and Nick Fleisher are a diverse, talented, and compassionate group of people; I feel proud to count myself among them. Other Berkeley folks who provided intellectual and personal inspiration include Molly Babel, Jonathan Barnes, Amy Campbell, Lisa Conathan, Reiko Kataoka, Yuni Kim, Jenny Lederer, Teresa McFarland, Ashlyn Moehle, David Mortensen, Linsey Newbold, Pawel Nowak, Mary Paster, Alysoun Quinby, Ruth Rouvier, Eurie Shin, Ryan Shosted, Sam Tilsen, and Alan Yu. Extra-special thanks to Gunnar Hansson, who took the trouble to introduce me to Sharon Inkelas many years ago. Raul Aranovich and Suzanne Gessner, while not technically denizens of Berkeley, belong on this list too.

In Fall 2005, I had the privilege of meeting Hupa speaker Verdena Parker and her daughter Becky. Although we only had a few meetings over the course of the next several years, Verdena and Becky had a profound impact on me personally as well as professionally -- a bit of this can be glimpsed in Chapter 4 of the dissertation, the content of which was inspired by a detailed dream that I had after a day-long elicitation session with Verdena.

My friends from my previous life could not be more amazing: Bret Peterson, Alison Dallmer, Kristin DeVivo, Linda Dugoni, Molly Giss, John Horsch, Caroline

Kraus, Kim LaRossa, Didi Linburn, Betsy Merzenich, Steve Miller, Lindsay Swain, Steve Wright, Megan Younoszai, and the one and only Miss Thet Shein Win. Sadly, no one on this list can hold their beer the way they used to, but nevertheless...what a pleasure to be among you. Your presence in my life helped make this dissertation possible.

For the past two years, Mariela Divas has cared for my son Milo. Mariela provided him with so much love and wisdom that I was able to focus on my dissertation without ever once worrying about the care that he was receiving -- I cannot imagine a better gift to give a working mother, and I never would have finished this dissertation without her.

My parents-in-law, JacSue and Philippe Ascher, welcomed me into their family despite my awkward French and mid-western ways. They have provided personal and financial support in numerous ways, for which I am deeply grateful. My sister-in-law Emily Pickett refrained from telling me not to go to graduate school in linguistics; she and family members David, Hugo, and Sylvia Ascher have been sources of happiness and fun. My grandfather Jim Dinauer also refrained (mostly) from making snide comments about the lengthiness of my education; he and my grandmother Betty Dinauer are sorely missed. My brother Carl Pycha refrained from laughing while watching me ski, and showed me the best brewpubs in Colorado.

My parents, Marguerite and Chuck Pycha, have been a constant presence in my life. They have called me, visited me, advised me, comforted me, and sent me money even when I did not ask for it. I cannot thank them enough for the wonderful gifts they have given, and continue to give, to me as their daughter.

The inimitable Ivan Ascher is my husband, and still the most interesting person that I have ever met. Though exposed to many of his secrets, I have not yet cracked his code of mesmerizing charm, tender lovingness, and meticulous intellect. The indefatigable Milo Ascher is our son, and a total joy. Although no one will be able to see it but me, every page of this dissertation is infused with love for Ivan and Milo.

Chapter 1: Introduction

The starting point for the current study is the puzzle of diverse sound alternations that occur in the same environment. In Finnish (Karlsson 1999), for example, the following stem alternations occur with the addition of the nominative singular morpheme.

Finnish (Karlsson 1999: 32)

	Stem	Nominative singular	Gloss
Degemination	saappaa-	saapas	'boot'
	rattaa-	ratas	'wheel'
	rakkaa-	rakas	'dear'
Voicing	hita-	hidas	'slow'
	varpaa-	varvas	'toe'
Deletion	kokee-	koe	'experiment'

These alternations -- degemination, voicing, and deletion -- appear diverse because phonological theory has traditionally proposed very different mechanisms to explain them. Degemination changes the quantity or weight of a segment; voicing changes a feature of a segment; and deletion removes a segment altogether. One widely-invoked solution to this puzzle has been to arrange the consonants in question along a strength scale (e.g. Foley 1977). The scalar formalism, familiar from earliest work on sonority (Jespersen 1904), imposes a linear order on segment types; for example:

Strong *Weak*
Geminates > Voiceless stops > Voiced stops > Voiced fricatives > ∅

Scales essentially smooth over differences in quantity and features, and therefore help to unify diverse alternations such as those we see in Finnish.

But the invocation of strength comes at a cost. As Bauer (1988), Dickens (1984), and others have pointed out, *strength* is an abstract concept that does not make reference to any parameter outside of the alternations it is designed to explain. The individual items on a strength scale can therefore be re-arranged to suit the idiosyncrasies of individual languages, leading to a proliferation of strength scales that do not necessarily have predictive value for other patterns in other languages. This is not to say that the scalar formalism itself cannot prove useful, but that the ordering of constituents along a scale should ideally make reference to an independent parameter.

The domain of phonetics would seem a promising place to seek such an independent parameter, and previous proposals have been grounded in articulatory observations. For example, Ohala (1997) argues that decreases in consonant strength (i.e., lenition) have their basis in an aerodynamic voicing constraint, while Kirchner (2000) argues that they have their basis in articulatory laziness. Each of these proposals offers an independent parameter for the linear ordering of scales, and therefore has predictive value. The problem, however, is that they explicitly do *not* predict change in the opposite direction; that is, they do not predict processes of consonant fortition. Yet such cases are well attested. Whereas lenition in Finnish includes voicing and deletion, fortition in languages like Northern Sotho (Poulos & Louwrens 1994) includes the mirror-image alternations of devoicing and insertion.

Finnish	Stem	Nom.singular	N. Sotho	Stem	Class 9/10
Voicing	/hita-/	hidas 'slow'	Devoicing	/-bal/	palô 'number'
Deletion	/kokee-/	koe 'experiment'	Insertion	/-ilêl-/	kilêlô 'a taboo'

Ideally, a theoretical approach to this puzzle should be able to handle both the lenition pattern as well as its mirror image.

In this study, I offer a proposal called Resizing Theory. Resizing Theory retains the insights offered by the formalism of scales and by the domain of phonetics, but avoids some of the problems raised by previous proposals. In Resizing Theory, scales are constructed according to the independent parameter of *size* in a particular dimension, such as length, tone, or sonority. In our Finnish example, the relevant dimension is length, and no other parameter plays a role. This creates a scale that is, at first blush, similar to the strength scale:

<i>Long</i>	<i>Short</i>
Geminates > Voiceless stops > Voiced stops Voiced fricatives	> Ø

But there are two key differences between this scale and the strength scale. First, voiceless consonants are not considered stronger than voiced ones, but rather are considered to be explicitly *longer*. This is where the insight from phonetics comes in. As established by a wide range of phonetic studies (reviewed in §3), voiceless stop consonants are consistently longer than their voiced counterparts. By treating an alternation such as t ~ d as a *length* alternation rather than a voicing one, we justify the

placement of voiced consonants on the scale according to an independent parameter, rather than an ad-hoc one. Second, fricatives have no special status on this scale. Their manner of articulation does not affect their length, so they are grouped along with stops that have the same voicing value.

The Resizing Theory analysis of Finnish, then, states that the addition of the nominative singular morpheme has a single, unified effect: it shortens the stem (or *downsizes* the stem in the dimension of length). For degemination, this is uncontroversial: the alternation from geminate to singleton obviously involves a decrease in length. For voicing, I am claiming on the basis of phonetic evidence that the alternation from voiceless to voiced consonant *also* involves a decrease in length. And for deletion, the alternation from a consonant to nothing obviously involves a decrease in length, even though it has not always been treated explicitly as such. The analysis of Northern Sotho is identical, except that the relevant alternations occur in the opposite direction: the Class 9/10 morpheme lengthens the stem (or *upsizes* it), either by devoicing a consonant or epenthesizing one.

In both languages, then, the presence of a particular morpheme triggers a conspiracy effect: stems must get shorter in Finnish and longer in Northern Sotho, but it does not particularly matter how this happens. The notion of a conspiracy is familiar from Optimality Theory (e.g. McCarthy & Prince 1993), which proposes that such effects derive from high-ranked constraints interacting with lower-ranked ones, an idea is not incompatible with Resizing Theory. Still, the conspiracy effects that I discuss in this study are unique because they encompass both featural and segmental phonology, two

domains that Optimality Theory is not yet equipped to unify. A major goal of Resizing Theory is to lay the groundwork for such unification.

Because Resizing Theory encompasses not just traditional notions of length (or “quantity” or “weight”) but also novel ones, I will refer not to length but more generally to *size*. Shortening will be re-cast as *downsizing* in the length domain, and lengthening will be re-cast as *upsizing*, while *resizing* refers collectively to these two types of change. The use of these general terms not only frees us from older notions of length, but also highlights the ways in which Resizing Theory can apply to other dimensions, such as tone, a topic that I take up in a later chapter.

Crucially, in Resizing Theory, alternations that do not affect the size of a constituent play no role in the linear ordering of items on a scale. Such alternations include frication and nasalization, among others. In Finnish, then, the scalar movements $t > d$ and $p > v$ have exactly the same status: they are operations that downsize a constituent via voicing. The fact that [v] is a fricative, rather than a stop, has no effect on this status, and is considered orthogonal to the higher-order requirement for downsizing. Traditional strength scales, by contrast, impose a relative ordering between such segment types, but this ordering has no basis in an independent parameter and therefore does not have predictive value.

The inclusion versus exclusion of features like frication amounts to a key difference between Resizing Theory and traditional strength scales. This difference may seem, at first blush, not terribly significant. But, as I will attempt to show throughout the pages that follow, the use of size as the sole independent parameter for scales takes us well beyond a felicitous treatment of consonant voicing alternations, and allows us to

predict and analyze other size alternations as well. This is important because resizing can encompass more than individual segments; it can also encompass *multiple* segments. In Choctaw (Haag & Willis 2001), for example, the resolutive aspect morpheme triggers gemination of the consonant that begins the penultimate syllable of the verb stem. In stems of less than three syllables, however, the resolutive aspect triggers the insertion of [jjV], where V is a copy vowel.

Choctaw (Haag & Willis 2001: 168)

Stem	Resolutive aspect
hoponi	→ hópponi
foha	→ fójjoha

In previous theories based on strength, gemination possesses a status on the scale, but the insertion of three arbitrary segments does not. This leaves us no straightforward way to analyze the Choctaw data. Under Resizing Theory, however, these data fit right in with the Finnish data -- or more precisely, the Northern Sotho data -- because the notion of size is not confined to a segment.. Thus, the resolutive aspect morpheme consistently triggers upsizing of the stem, sometimes in the form of gemination and sometimes in the form of [jjo]-insertion.

Once we are no longer analyzing the properties of individual segments, however, the question arises as to what exactly we are analyzing. In this study, I claim that size is a characteristic not of individual segments per se, but of the constituents in which they are embedded. The constituent with which we will be primarily concerned is the morpheme. In the Finnish, Northern Sotho, and Choctaw data, it is always the overall size of the stem morpheme that changes. Specifically, my claim will be that the stem morpheme resizes

because it comes into *contact* with another morpheme. In Resizing Theory, then, overall morpheme size is manipulated directly by contact relationships with other morphemes.

Resizing Theory also claims that contact relationships consist not just of a boundary symbol but of a meaty internal structure. Instead of /saappaa-s/ ‘boot-NOM.SG’, where the presence of contact between the stem and suffix morphemes is marked with a dash but contains no structure, the relationship is re-conceptualized as /saappaa◁s/. The triangle is intended to be iconic, indicating that contact strength is concentrated on right side of the boundary and diminishes on its left side. The lopsidedness in strength triggers alternations in the length dimension, downsizing the stem to [saapa-]. Of course, I am invoking a very different notion of “strength” than that which has been previously used to describe consonant alternations; in this study, strength refers only to the relationship between one morpheme and another. The concept of strength retains its arbitrary quality but, insofar as it now describes relationships between morphemes, which are a well-established domain of arbitrariness in language (versus relationships between phonemes, which we expect to be regular), this usage seems appropriate.

Using an enriched structure for contact relationships allows us to capture the fact that certain alternations are related to one another even when they do not serve the same higher-order goal. In Finnish, resizing alternations all serve as a marker of the nominative singular morpheme. In T^hese (Yip 2004), however, different resizing alternations serve as markers of different morphemes. For example, the second singular imperfect triggers an alternation from flap to stop, while the first person perfect triggers an alternation from flap to voiceless geminate.

These (Yip 2004)

Example	Contact relationship		Movement on scale
à-ɽɔk ^w ɛ 'I plant'	(none)		(none)
ɛ-ɖɔk ^w ɛ 'you (sg) plant'	Roots ▷ 2sg . Impf	"The boundary between roots and 2SG.IMPF requires relative strengthening on its left side and/or relative weakening on its right."	Upsizing of root: ɽɔk ^w ɛ → ɖɔk ^w ɛ
á-tɬɔk ^w ɛ 'I planted'	Roots ▷ 1sg . Pf	"The boundary between roots and 1SG.PF requires a <u>lot</u> of relative strengthening on its left side and/or relative weakening on its right."	More upsizing of root: ɽɔk ^w ɛ → tɬɔk ^w ɛ

In Resizing Theory, the relationship between these alternations is captured by morpheme contact relationships which are essentially the same, but characterized different degrees of lopsidedness, as symbolized by the triangles. That is, roots must strengthen somewhat relative to the 2SG.IMPF, while they must strengthen quite a bit relative to the 1SG.PF. This results in different degrees of upsizing on the root; alternation to [d] represents one degree while alternation to [tɬ] represents a further degree. In a feature- and segment-based theory of phonology, on the other hand, there would be no straightforward way to capture the observation that these alternations are related, because one alternation involves [-continuant] while the other involves [-continuant] and [-voice], as well as the insertion of a timing unit.

The use of the independent parameter of size allows us to extend this idea even further. In Hupa (Golla 1970, 1996a), morphemes such as the classifier *di-* and the first person *m-* trigger alternations in the perfective *win-*: sometimes it loses one segment, reducing to *wi*, and sometimes it loses all of its segments, reducing to \emptyset .

Hupa (Golla 1970, 1996a)

Example	Contact relationship		Movement on scale:
yehtʃ' iwiŋyay 'he went in'	(none)		(none)
yehwidqot' 'it wiggled in'	PERF < di	"The boundary between Perf and <i>di</i> requires relative weakening on its left side and/or relative strengthening on its right."	Downsizing of perfective: win → wi
ne:moʔn 'I have been good'	PERF < μ	"The boundary between Perf and <i>μ</i> requires <u>a lot</u> of relative weakening on its left side and/or relative strengthening on its right."	More downsizing of perfective: win → ∅

In Resizing Theory, again, the relationship between these alternations is captured by morpheme contact relationships which are essentially the same, but characterized different degrees of lopsidedness. We are thus able to see that the characteristic feature of both the *di*- and *μ*- morphemes is that they chip away at the size of the perfective morpheme. In a segment-based theory of phonology, by contrast, there would be no straightforward way to capture the unity behind the seemingly haphazard segment deletions.

Essentially, then, Resizing Theory claims that certain processes in phonology are best understood by taking a bird's eye view of the representation of individual constituents (that is, looking at their overall size rather than their individual segments and features) but, as a trade-off, taking a finer-grained view of the representation of the contact between them.

1.1 Overview of chapters

Resizing Theory makes a number of testable predictions and the goal of this study is to provide evidence for them. In Chapter 2, I pursue the prediction that alternations which upsize a morpheme in the length dimension should all pattern together. Epenthesis, gemination, and consonant devoicing all do this, so we predict that there should be cases in which these alternations, despite their apparent diversity, achieve precisely the same higher-level effect. A similar idea holds for deletion, degemination, and voicing, which downsize a morpheme. In Chapter 3, I pursue the prediction that contact relationships can determine surface outputs even when traditional constituents of phonological length, such as C and V timing slots, fail to do so. In Chapter 4, I pursue the prediction that contact with different morphemes should be reflected in a cline of morpheme variants (allomorphs) of different lengths. This has particular import when considering morphemes of zero length, or “null allomorphs,” which have traditionally received special treatment as cases of morphological blocking. Within Resizing Theory, null variants of a morpheme are not special, but simply represent the endpoint of downsizing. We therefore predict that there should be languages in which morphological blocking produces both partial and null allomorphs along the same cline. Although the problems of diversity and contact take on particular poignancy in the domain of length alternations at morpheme boundaries, they are found throughout phonology. Resizing Theory aims to offer a general solution to these problems, and its application to other domains is pursued in Chapter 5.

1.2 Overview of introduction

In the rest of this introductory chapter, I lay out the basic tenets of Resizing Theory and situate its contribution with respect to previous work. In §2, I use a working example to introduce the formalisms of Resizing Theory, namely contact representations and size scales. In §3, I present phonetic evidence in support of consonant length alternations, focusing in particular on re-conceptualizing alternations in consonant voicing as alternations in consonant size, which will be important in light of our empirical focus on length alternations. In §4, I show how relative size in Resizing Theory differ from other theories of scalar phenomena. In §5, I discuss where Resizing Theory overlaps with processes of consonant lenition and fortition, and where it diverges. And in §6, I show how the enriched representation of contact in Resizing Theory differs from proposals that have been advanced in previous work.

2. Formalisms and working example: Päri

Päri (Andersen 1988) and Finnish will provide working examples of Resizing Theory and serve to formalize its two principal ingredients: contact relationships and size scales. We will begin with Päri, which is a particularly interesting language to examine for Resizing Theory because of the large number of sizing alternations it exhibits in its verbal paradigm. Here we will examine just one downsizing alternation for demonstration purposes; in Chapter 2, I integrate this into a full analysis of Päri alternations.

In Päri, verb roots alternate when they combine with different suffixes. The

antipassive suffix, which like most other suffixes has no segmental realization of its own, triggers either voicing of the root-final consonant (when it is non-velar) or by deletion (when it is velar). The final [-o] is a separate intransitive marker.

Päri antipassive (Andersen 1988: 91)

Final C	Root	Antipassive (intransitive)	Gloss
/p/	yap	yλb-ò	‘open’
	lʊp	lûub-ó	‘speak’
/t̪/	t̪ʌt̪	t̪ud̪-ò	‘pierce’
	rɪt̪	rîid̪-ó	‘sew’
/t/	kλt	kλd-ò	‘plait’
	puot	pòod`-ò	‘beat’
/c/	kac	kλy-ò	‘bite’
	tuoc	toòy`-ò	‘tie’
/k/	yɪk	yì-ò	‘make’
	lʊk	lò`-ò	‘wash’

Roots ending in palatal /c/ undergo a concomitant alternation to approximant manner of articulation, becoming [y]. As the data shows, changes in the root vowel and tone pattern also occur, which we will not consider here. The third singular morpheme, not shown here, shows the same set of alternations as the antipassive (see Andersen 1988: 97).

The basic insight into Päri is that the unifying effect of the antipassive is to downsize, or shorten, root morphemes. In the case of velar-final roots, downsizing occurs because the final consonant is deleted. In the case of other roots, downsizing occurs because the final consonant becomes voiced, thereby rendering it shorter than its voiceless counterpart. The phonetic evidence for re-conceptualizing voicing as a length alternation is presented in §3.

We know that voicing and deletion in Pāri are morphological effects, and not phonological effects of an intervocalic environment. Evidence for this comes from the Centrifugal Antipassive morpheme, which produces voiceless stops in the same phonological environment, cf. *yap* → *yàpò* ‘open.CENTRIFUGAL.ANTIPASSIVE’, *tut* → *tùtò* ‘pierce.CENTRIFUGAL.ANTIPASSIVE’, and so on (Andersen 1988: 91). We can therefore be confident that the Pāri data are a clear example of morpheme contact.

2.1 Contact relationships

Under Resizing Theory, the contact relationship between these two morphemes can be represented with a triangle as follows.

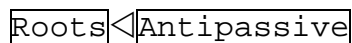

“The boundary between roots and antipassive requires a relative weakening on its left side and/or a relative strengthening on its right. Edges only.”

As mentioned, the triangle is intended to be iconic, indicating that strength diminishes on the left side of the boundary, which is in contact with the root, and is concentrated on the right side, which is in contact with the antipassive. The lopsidedness in strength triggers alternations in size along the length dimension.

Again as shown by the triangle, the width of the morpheme boundary does not extend past the edge of either morpheme. That is, it makes contact with the right edge of roots and with the left edge of the antipassive morpheme, but it does not overlap with either. A contact relationship of this shape has only local effects, and most of the examples in the current study will be of this type. A contact relationship with greater

width, however, can have non-local effects, which we will see when we examine Finnish in a subsequent section.

What consequence does this contact relationship have? I will claim that, as a basic tenet of Resizing Theory, contact relationships serve as the trigger for surface phonological changes. Put somewhat more formally:

CONTACT RELATIONSHIPS between constituents drive changes in their relative size. That is, the contact relationship represents a grammatical requirement of the language which must be manifested on the surface. In our current example, the contact relationship requires that the root downsize in length, and that the downsizing occur at the edge of the root.

2.2 Relative size scales

This brings us to scales, the formalism used by Resizing Theory to implement the notion of relative size. The definition of a scale is below.

SCALE: a size-based ordering of the surface variants of a linguistic constituent along a particular dimension.

In Päri, then, the scale is an ordering of surface variants of a morpheme, along the dimension of length. In other words, the scale arranges allomorphs according to how short or long they are. For the root /kʌt/ ‘plait’, for example, we have the variants [kʌd] and [kʌt]. The first variant is shorter in length because voiced consonants such as [d] have shorter durations than their voiced counterparts such as [t]. So the scale for this root

arranges the variants as follows, with the shorter variant on the “Down” side and the longer variant on the “Up” side.

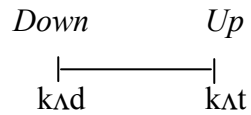

The scale for any other root which ends in /p, t, c/ will be isomorphic to the scale for /kΛt/ ‘plait’: it will possess the same number of points, each representing one variant, and the difference between these points will be the same, corresponding to the difference in length between a voiced and a voiceless consonant. Some examples are below.

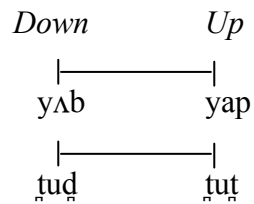

Roots that end in [c] have a surface variant that ends in [y]. These variants are arranged on the scale in precisely the same fashion as the others; the concomitant manner alternation has no effect on the size of the constituents, which is defined solely by the contrast in voicing.

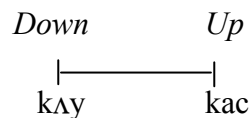

The scale for velar-final roots will differ, however. For the root /yɪk/ ‘make’, for example, we have the variants [yɪ] and [yɪk]. The first variant is shorter in length because

it contains only two segments, while the second variant contains three. Arranging the variants from shorter to longer produces the following scale.

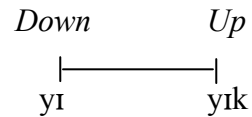

Obviously, the scale for velar roots is not isomorphic to the other root scales. While it contains the same number of points (two), the difference between these points is not the same. Under Resizing Theory, non-isomorphism is permitted and even expected, provided that the non-isomorphism has its basis in phonological considerations. It is the natural class of velar segments in Pāri which divides its scales into two types; this is clearly a phonological parameter, rather than a morphological one.

NON-ISOMORPHICITY: The scales for a particular type of morpheme may diverge and become non-isomorphic for purely phonological considerations, such as natural classes of segment types.

Scales can also be non-isomorphic in a more dramatic way, namely by containing different numbers of points. The language T^hese, discussed in Chapter 2, will provide an example of this.

We are now ready to see how contact relationships drive movement along the scale. Every scale has a starting point, indicated with a black circle and defined as follows.

STARTING POINT for scalar movement: The variant which would occur when *no* contact relationship is operative.

In most cases, the starting point for a morpheme variant is its underlying form, as established by traditional criteria. In a few cases, this definition yields a starting point that is different from the underlying form; such cases will be discussed individually as they arise (see, for example, the analysis of T^hese in Chapter 2). For Pāri, the starting points for /kʌt/ ‘plait’ and /yɪk/ ‘make’ are as follows.

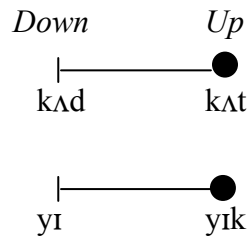

In the formation of the antipassive, the root variants obviously do not remain at their starting points. The contact relationship between the root and the antipassive requires root downsizing, triggering movement downward on the scale as follows.

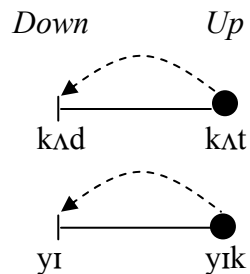

The examples above illustrate a crucial issue about Resizing Theory, which is that scalar movement is totally blind to non-isomorphicity of scales. A one-point downward

movement occurs on every Pāri root scale, regardless of any potential difference between individual points. This is one of the central features of Resizing Theory because it allows us to offer the same analysis of alternations (here, voicing and deletion) that would require separate analyses in previous theories.

I referred to the Pāri alternation as a one-point movement on the scale, but actually, it could also be analyzed as an end-point movement, where the latter requires movement all the way to the downsizing (or upsizing) end of a scale. Because the Pāri root scales only contain two points, there can be no difference between these two types of movement, and choosing between them is not possible. In subsequent chapters, however, we will see examples of languages that distinguish between one-point and end-point movements (These in Chapter 2, Western Shoshoni in Chapter 3, and Hupa and Kanuri in Chapter 4); these movements are triggered by different degrees of strength relationships at contact.

Following Mortensen (2006), I hypothesize that scalar movements are constrained to just these two types.

INVENTORY OF SCALAR MOVEMENTS: There are only two types of movement that can occur on a scale:

- One-point movements upsize or downsize a variant by one point.
- End-point movements move a variant to the maximally upsized or maximally downsized end point.

In Resizing Theory, contact relationships which are relatively more lopsided will be strong enough to trigger end-point movements, while those which are relatively less

lopsided will trigger only a one-point movement. But no contact relationship specifically dictates a two-point movement or a three-point one.

2.3 Formalisms and working example: Finnish

The Resizing Theory analysis of Finnish is almost identical to that of Pări. The only parameter that differs is the *width* of the morpheme contact relationships that are involved. Recall the Finnish data, in which degemination, voicing, and deletion occur when a stem combines with a nominative singular suffix.

Finnish (Karlsson 1999: 32)

	Stem	Nominative singular	Gloss
Degemination	saappaa-	saapas	'boot'
	rattaa-	ratas	'wheel'
	rakkaa-	rakas	'dear'
Voicing	hitaa-	hidas	'slow'
Deletion	varpaa-	varvas	'toe'
	kokee-	koe	'experiment'

As with Pări, then, the stem downsizes when it combines with another morpheme. In Finnish, however, the downsizing is not strictly local: that is, the consonant which is targeted for shortening does not lie on the edge of the stem, but is internal to it. This fact can be captured by widening the contact relationship.



“The boundary between Stems and Nominative Singular requires a relative weakening on its left side and/or a relative strengthening on its right. On its left, the boundary overlaps with Stems.”

As before, the triangle is meant to be iconic; the boundary between a stem and the NOM.SG overlaps with the material internal to the stem. Therefore, the relationship between these two morphemes will be realized not by purely local resizings, but by non-

local ones. Non-local changes like this are less common than local ones, and therefore form a relatively small proportion of the examples used in this study. But it is important to note that Resizing Theory, with its proposal for contact relationships with meaty internal structure, allows for the setting of width parameters in such relationships, and therefore encompasses the Finnish pattern. Interestingly, the long vowels on the right edge of the Finnish stems also downsize (e.g., /aa/ → [a]) along with the target consonants, as predicted by a relationship that requires overall downsizing in the stem.

2.4 Alternative explanations for the Päri and Finnish patterns

The pattern exhibited by Päri and Finnish, in which velars delete in the same environment where other consonants undergo voicing, is not unusual. It is also found in Turkish (Altaic, Turkey; see Chapter 2 for an analysis). Ohala (1997) as well as Blevins (2005) have offered a diachronic explanation for this pattern, which they call the Aerodynamic Voicing Constraint. To produce voicing, speakers must maintain a pressure differential across the glottis. In articulations with a complete closure at the back of the vocal tract, such as velar stops, the cavity formed above the glottis is so small that the differential disappears rapidly and voicing can be maintained for only a short time, leading to potential deletion of the segment over time. In articulations with a complete closure toward the front of the vocal tract, the cavity is larger, voicing can be maintained for a longer time, and there is less tendency toward deletion.

This explanation, while compelling, has two shortcomings. The first shortcoming is that it only explains cases of velar deletion. But cases of velar insertion are also attested. In Northern Sotho, velar consonants are epenthesized in the same environment

where other consonants undergo devoicing. In Resizing Theory, this situation can be synchronically analyzed in exactly the same fashion as we have analyzed Pări (I pursue this analysis in Chapter 2). The only difference is that the contact relationship between the relevant morphemes requires upsizing rather than downsizing.

The second shortcoming of the Aerodynamic Voicing Constraint is that it does not readily extend to other cases of upsizing and downsizing that occur as the result of contact. As I touched upon in §1, changes in the relative size of a constituent can occur not just in the length dimension, but also in the dimensions of tone and sonority. And such changes are not limited to a single direction, but may occur in both upsizing and downsizing directions. Tone, for example, may undergo downstep or upstep. Sonority may be required to fall (across a syllable boundary, for example) or to rise (from onset to nucleus). The fact that upsizing and downsizing occur in multiple phonological dimensions, and that relative changes in size are attested in both directions, points to the need for a more general theory.

2.5 Resizing Theory and Optimality Theory

As presented in this study, the formal machinery of Resizing Theory has been kept to a minimum. There are two reasons for this. First, simplifying the machinery highlights the bigger claim that I wish to emphasize: namely, that a focus on relative size can reveal the unity which underlies certain types of morpho-phonological alternations. Second, some of my predecessors have already devoted attention to the formal mechanisms needed to integrate scalar operations with existing theories of phonology, such as Optimality Theory (McCarthy & Prince 1993). For explicit proposals in this

regard, the reader is referred especially to Mortensen (2006), and also to Gnanadesikan (1997), DeLacy (2002), and Gouskova (2004). My study draws implicitly (and sometimes explicitly) on this previous work.

3. Phonetic evidence for consonant length

Resizing Theory highlights the relative size of linguistic constituents. As will become more and more clear, however, the theory does not attend to the particular *source* of changes in relative size. In fact, the scales of Resizing Theory, which order variants along a particular dimension such as length or tone, produce a flat, linear structure which factors out such differences in source. This is, crucially, what provides us with the opportunity to unify certain so-called effects in phonology. In the tonal domain, for example, it has frequently been observed that voiced consonants tend to co-occur with low tones, which can interact with lexical tones (Hyman 1973, Bradshaw 1999, Yip 2002). Resizing Theory allows us to construct a scale in which the two types of tones can have the same status, regardless of their diverse sources (see Chapter 5). In the segmental domain, a large body of phonetic evidence supports the idea that voiced consonants are relatively short in duration while voiceless consonants are relatively long. This observation played a role in our analysis of Pări, allowing us to construct a scale in which consonant voicing has the same status as other sources of length. Because this observation will also play a role in the analysis of subsequent languages in this study, and indeed constitutes one of the core pieces of evidence in my attempt to unify diverse phonological processes, I will review the literature on the subject here.

In re-conceptualizing consonant voicing as a length alternation, I am following the lead of Kohler (1984) and Kluender, Diehl & Wright (1988). Although they tread very different paths, both studies argue that consonant gemination and consonant devoicing are members of the same family of alternations. Gemination is, of course, the parade example of a phonologically significant segmental length alternation, so any connections that we can draw between the behavior of geminate and that of voiceless consonants will be significant. I begin by considering the phonetic evidence in favor of unifying gemination and devoicing, and finish by discussing how such phonetic evidence should be integrated into a theory that proposes to treat higher-level, abstract patterns.

3.1 Raw phonetic duration

It is well-established that phonetic duration is the primary correlate of consonant gemination. A difference in total duration between singleton and geminates has been demonstrated for Bengali (Indo-European, Bangladesh; Lahiri & Hankamer 1988), Cypriot Greek (Indo-European, Cyprus; Arvaniti & Tserdanelis 2000, Payne & Eftychiou 2006), Finnish (Richardson 1998, cited in Aoyama & Reid 2006), Guinaang Bontok (Austronesian, Philippines; Aoyama & Reid 2006), Hungarian (Magdics 1969, Ham 2001, Pycha 2007), Japanese (Isolate, Japan; Sato 1998, cited in Aoyama & Reid 2006), Italian (Indo-European, Italy; Payne 2005), Malayalam (Dravidian, India; Local & Simpson 1988, 1999), Pattani Malay (Austronesian, Thailand; Abramson 1986), Sardinian (Indo-European, Italy; Ladd & Scobbie 2003), Swiss German (Indo-European, Switzerland; Ham 2001), and Turkish (Lahiri & Hankamer 1988).

Although this fact is well-established in a number of languages, it should not necessarily be taken for granted. Phonetic repetition (that is, re-articulation) has also been argued to be a primary correlate of gemination. Delattre (1971a, 1971b), for example, presented data to argue that geminates in English, French, German, and Spanish are characterized by two distinct phases of articulation, one for each “half” of the geminate. Lehiste, Morton, and Tatham (1973) presented similar data for English and Estonian. For both sets of authors, however, gemination actually refers not to the distinction between a singleton and a geminate per se, but to the juxtaposition of two identical consonants (as in one of Delattre’s test sentences, *I’ve seen Nelly*), commonly referred to in the literature as “fake” geminates. It is significant that no study of “true” geminates, which are the only type of geminates that are under investigation in this study, has found evidence of re-articulation; instead, duration always serves as the primary correlate.

It is also well-established that phonetic duration is a robust correlate of consonant voicing, at least for stops. There are two types of phonetic duration that appear to play a role: total closure duration and voice onset time (VOT). Lisker (1957) measured closure duration in English words such as *rupee* and *ruby*, *rapid* and *rapid*, *stable* and *staple*, and found that closure duration is greater for voiceless /p/ (90-140 ms, average 120) than for /b/ (65 to 90ms, average 75). Furthermore, closure duration alone is a sufficient perceptual cue to the distinction between such words, at least when the closure duration exhibits no glottal pulsing, as in Lisker’s experiment. The other potential cues to voicing, such as formant transitions preceding and following the target consonant, balanced the effect of a 30 ms difference in closure duration (Lisker 1957: 47). A subsequent study which examined the intra-oral air pressure during the production of English /p/ and /b/

confirmed that the voiceless and voiced categories differ dramatically in closure duration, although this finding was restricted to medial post-stress position (as in words like *tepid*) (Lisker 1972).

In initial position, it is VOT which appears to be a primary correlate of the voicing distinction for stops (and furthermore, of the distinction between unaspirated and aspirated stops). VOT is defined as “the duration of the time interval by which the onset of periodic pulsing either precedes or follows release” (Lisker & Abramson 1964); in the case of voiced stops, the periodic pulsing in question belongs to the consonant itself while in the case of voiceless stops, the pulsing belongs to the following vowel. For voiced stops, VOT typically has a negative value; for voiceless stops, it has a positive value. Lisker & Abramson (1964) showed that VOT reliably separates the different stop categories in American English, Cantonese, Dutch, Hungarian, Puerto Rican Spanish, Tamil, as well as in Korean, Eastern Armenian, and Thai. Furthermore, VOT is a sufficient perceptual cue to the distinction between voiceless and voiced stops in American English, Spanish, and Thai (Lisker & Abramson 1970).

3.2 Duration ratios

Gemination and voicing share another important phonetic characteristic. In both cases, “raw” durations are accompanied by adjustments in “relative” duration. Thus in many languages, the vowel preceding a geminate consonants is short, while the vowel preceding a singleton consonant is long. For example, Josselyn (1900) reports the following duration measurements for Italian (cited in Saltarelli 1970):

Durations in hundredths of a second

	V	C
V' + C (<i>pane</i>)	26	14
V' + CC (<i>panni</i>)	17	24

Saltarelli (1970) refers to this as a law of “rhythmic duration” whereby V:C sequences in Italian alternate with VC: sequences. Maddieson (1985) claims that such a law occurs almost without exception in languages with distinctive length, and cites over twenty languages as examples: Amharic, Arabic, Bengali, Dogri, Estonian, Finnish, Hungarian, Galla, Gowda, Hausa, Hindi, Icelandic, Italian, Kannada, Koya, Malayalam, Norwegian, Punjabi, Rembarnga, Shilha, Sinhalese, Swedish, Tamil, Telugu, Ulithian (cited in Kluender, Diehl & Wright 1988: 161).

Similarly, in many languages, the vowel preceding a voiceless consonant is short, while the vowel preceding a voiced consonant is long. A simple example comes from English, where the vowel of /bit/ ‘beat’ is longer than that of /bid/ ‘bead’ (Pederson & Lehiste 1960, Sharf 1962). Similar findings have been reported for many other languages, including Danish, Dutch, French, German, Hindi, Hungarian, Italian, Korean, Norwegian, Persian, Russian, Spanish, Swedish (Kluender, Diehl & Wright 1988: 153, and references cited therein). Furthermore, for English at least, vowel duration is a sufficient perceptual cue to voicing distinctions. Raphael (1972) showed that regardless of the cues used for actual “voicing” in a word-final consonant, short vowel duration cued the percept of voicelessness while long vowel duration cued the percept of voicing (see also Denes 1955; Port & Dalby 1982; Raphael 1975; Raphael, Dorman, Freeman, & Tobin 1975; Raphael, Dorman, & Liberman 1980; Raphael 1981).

3.3 Phonetic facts and higher-level patterns

While there is abundant evidence that duration is a primary phonetic correlate of both the singleton-geminate distinction and the voiced-voiceless distinction, a particular phonetic realization need not dictate a particular grammatical analysis. We know, for example, that inherent durational differences between certain segment types, such as that between high vowels and low vowels, do not seem to play a role in abstract grammar (Lehiste 1970), and we also know that languages may implement the same abstract distinction in phonetically very different ways (Keating 1984). Furthermore, many processes on either side of the phonetics-phonology divide resemble one another quite closely (Flemming 2001). For example, low-level co-articulation between adjacent segments is pretty similar to abstract assimilation, yet co-articulation as such has no real status in a grammar. One might argue, in a similar vein, that while duration differences in voiceless versus voiced consonants do resemble the length distinctions in singleton versus geminate consonants, they have no status in the grammar.

The best we can do, I think, is to say that there is certainly enough evidence to justify a thought experiment in which we invert the traditional roles of voicing and length. That is, it behooves us to see what happens when we treat the length distinction on “voiced” versus “voiceless” consonants as the primary one, and the voicing distinction as the secondary one. It is just such a thought experiment which provides the motivation for the language examples presented in Chapter 2, which are analyzed within Resizing Theory. But a couple of shorter examples should suffice to show that such a thought experiment could be headed in the right direction. Consider San Lucas Quiaviní Zapotec (Oto-Manguan, Mexico; Munro & Lopez 1999). This language has two consonant series,

termed fortis and lenis. For sonorants, the fortis category gets realized with increased duration. Thus fortis /ll, mm, nn, nng/ contrast with lenis / l, m, n, ng/. For obstruents, the fortis category gets realized with voicing. Thus fortis /p, t, c, s/ contrast with lenis /b, d, g, z/. The important point is that vowels lengthen before consonants in the lenis series; that is, before sonorant singletons and voiced singleton obstruents. On the other hand, vowels are banned from lengthening before consonants in the fortis series; that is, before sonorant geminates and voiceless singleton obstruents. Thus, geminates and voiceless consonants form part of the same abstract category in SLQ Zapotec. The only way to unify them from a theoretical perspective is to give the relative sizes of the consonants an independent status in the grammar, as Resizing Theory aims to do.

A different type of example comes from Blackfoot (Algic, Canada; Frantz 1991: 2). In this language, geminates trigger shortening of a preceding long vowel: e.g. *isska* ‘pail’ versus *míini* ‘berry’. Geminates also, however, trigger reduction of a preceding short vowel. The vowel /a/ becomes [ʌ], /o/ becomes [ʊ], and /i/ becomes [ɪ]: e.g. [a]mo ‘this’ versus [ʌ]nnia ‘that’s it/okay now’; [o]ma ‘that one’ versus [ʊ]nni ‘his father’¹. Such reductions in vowel quality are typically indicative of decreased vowel duration (Barnes 2006). Geminates in Blackfoot thus have a unified effect on the preceding vowel: that is, they trigger downsizing. The only way to capture this unified effect, however, is to take a bird’s-eye view of vowel duration, and thereby to treat the shortening of long vowels and the reduction of short vowels as one and the same process.

¹ The IPA transcriptions that I have written here are inferred from the description in Frantz (1991:1-2), which states that *a* has the quality of the vowel in English *father*, except before double consonants where it is like the vowel of *cut*. Likewise *i* alternates between the quality of the second vowel in *machine* and the vowel in *kiss*, and *o* alternates between the vowel of *so* and the first vowel of *woman*.

It is evidence of the sort that we see in SLQ Zapotec and Blackfoot, where changes in phonological duration clearly pattern with changes in phonetic duration, that offer the strongest argument for analyzing the latter as a true phonological effect. I present further examples of this sort in Chapter 2.

3.4 Where are timing units?

Gemination and epenthesis play important roles in this study. In previous theories of phonology, these processes are analyzed with reference to quantal units of length, such as timing slots or moras (the literature on gemination is particularly large; see e.g. Kenstowicz 1982; Clements & Keyser 1983; Hyman 1985; Clements 1986; Hayes 1986a, 1986b; McCarthy 1986; Schein & Steriade 1986; Tranel 1991; Elmedlaoui 1993; Inkelas & Cho 1993; Davis 1994; Hume, Muller, & van Engelenhoven 1997; Odden 1998; Rose 2000; Kraehenmann 2001; Muller 2001, 2002). In Resizing Theory, by contrast, these processes are analyzed only according to the effect that they have on relative size, with no reference to quantal units. Given a constituent /da/, for example, Resizing Theory allows that consonant gemination (\rightarrow [dda]) will upsize this constituent more than consonant devoicing will (\rightarrow [ta]), but the theory does not make any particular claim about “how much” more.

One of the primary motivations for this study, then, is to see just what a theory-sans-timing-units can accomplish. I stop short of making the strong claim that timing units do not exist, because the evidence that has been put forth in their favor is too copious for me to address all at once. Instead, I will review a few key pieces of this evidence and suggest ways in which Resizing Theory could conceivably do an equivalent,

or even better, job of accommodating the facts. This evidence comes from three sources: the behavior of geminates and consonant clusters, the syllabification of geminates, and patterns of total assimilation.

3.4.1 Geminates versus consonant clusters

In a timing slot theory of phonology (e.g. Clements & Keyser 1983), geminate consonants are predicted to behave similarly to consonant clusters, because both have identical representations on the timing tier.



That is, despite the differences in featural content and mechanism of association, these two representations should behave in exactly the same way for any process or constraint that makes crucial reference to the timing tier.

The phonotactics of Korean (Isolate, Korea; Sohn 1994: 439ff) bear out this prediction reasonably well, and provide the type of example that has motivated the development of timing slot theories. In Korean, consonant clusters are banned from word-initial position (with the exception of Cj and Cw, where the approximates arguably form part of the syllable nucleus, not the onset) and so are geminates. Consonant clusters are also banned from word-final position, and so are geminates. Furthermore, consonant clusters in word-medial position may contain a maximum of two C slots (again with the exception of CCj and CCw), which corresponds exactly to the number of C slots in a geminate.

This prediction is contradicted, however, by the cross-linguistic failure of clusters to participate in the same length ratios that geminates do. Recall the process of vowel shortening that, in many languages, occurs regularly before geminate consonants: thus in Italian, words like *pane* have a long vowel but words like *panni* obligatorily trigger vowel shortening (§3.2; Saltarelli 1970). The generalization for Italian, and for the numerous other languages which exhibit duration ratios, seems as if it must be about the number of timing slots, because that is the only thing which distinguishes the medial consonant in *pane* from that in *panni* (see Hayes 1989). Specifically, vowels shorten before a sequence of two C slots. Of course, this predicts that these languages should also exhibit vowel shortening before clusters -- but they do not.

There are many smaller, language-specific examples that could be given of the divergent behavior of consonant clusters and geminates, but the crucial point is already demonstrated by the cross-linguistic failure of clusters to participate in one of the hallmark processes of geminates. In Resizing Theory, this divergent behavior poses no particular problem because clusters and geminates do not have identical representations. Furthermore, Resizing Theory makes the more accurate prediction, which is that individual voiceless consonants, not clusters of consonants, should participate in duration ratios. (For an articulatory-based explanation of these facts, see Kohler 1984).

3.4.2 Syllabification of geminates

In a timing slot theory, geminate consonants in intervocalic position are predicted to span two syllables, e.g. [pan.ni]. This is because the geminate consonant consists of a sequence of two C slots on the timing tier, and universal syllabification preferences (see

e.g. Kahn 1976, Selkirk 1982) place the first C of such sequences into a coda, and the second C into the following onset. Hungarian appears to bear out this prediction, as do many other languages. In Hungarian, word-internal geminates syllabify as a sequence of coda plus onset: /ɔs.sɔj/ ‘woman’, /mɛ.ɟ.ɟɛk/ ‘sour cherry-PL’, and so on (Kenesei, Vago, and Fenyvesi 1998: 414). But Hungarian demonstrates just one of many possible syllabification algorithms available in natural language. I would like to suggest that in fact, the relatively long duration of a geminate consonant can be parsed into syllables in more than one way, and that there is no hard-and-fast requirement that a geminate must be parsed into two equal portions (for related discussion see Lisker 1974).

Consider Malayalam, where syllabification places geminate consonants entirely into the onset: [kaa.ppi] ‘coffee’ (Mohanam 1986: 73-74). Under Resizing Theory, this type of syllabification seems rather natural because there is no assumption that geminates consist of two timing units. Instead, geminates are just like singleton consonants except that they are somewhat longer; therefore, following universal syllabification preferences, geminates in intervocalic position syllabify into onset position just like any singleton consonant would. There is some interesting evidence in support of this point of view, which I draw from Inkelas & Cho (1993). In Hausa (Afro-Asiatic; Nigeria), for example, only sonorant consonants are permitted in coda position, but geminates seem to be immune to this constraint (*dabba*: ‘animal’). In Latin (Indo-European; extinct), only velar /l/ is permitted in coda position, but again geminates seem to be immune (*velle* ‘to want’). The cross-linguistic evidence is strong enough that Inkelas & Cho make the claim that geminates generally undergo onset-particular rules and constraints (1993: 550). Under their account, this is due to the pre-specification of features and the early versus late

application of rules. In Latin, for example, the idea is that onsets are fronted early in the derivation (geminate qualify as a target for fronting because they occupy onset position). Codas are backed later in the derivation, but at this point the frontness features of the geminate are already specified and inalterable.

But it seems simpler just to say that such geminates never occupied coda position in the first place. In Hausa, this would give us [*da.bba:*] ‘animal’, a form which does not violate the ban against obstruent codas because there is no coda -- the entire geminate is in onset position². In Latin, this would give us [*ve.llee*] ‘to want’, a form which does not violate the ban against fronted /l/ in codas because, again, there is no coda. In other words, these languages are just like Malayalam; they do not parse intervocalic geminates across two syllables, but simply place them into onsets.

This point of view flows naturally from Resizing Theory, but it does raise some questions. If geminates consist underlyingly of one long consonant (not two short ones), and if they are therefore subject to universal syllabification preferences which would place them in onset position, why do so many languages syllabify intervocalic geminates into coda-onset sequences, as in Hungarian? This type of syllabification is widely reported in published grammatical descriptions, including but certainly not limited to Sapir (1965) on Diola-Fogny; Lehiste (1960) on Estonian; Newman (2000) on Hausa; Urua (2000) on Ibibio; Rubino (2000) on Ilocano; Vance (1987) on Japanese; and Kimball (1991) on Koasati. A possible explanation lies in the tendency of native speakers

² However, Hausa allows contour tones only on long vowels, or on short vowels that are followed by a sonorant coda or a geminate consonant (Newman 2000, Sharon Inkelas p.c.), suggesting that these three cases form the natural class of CVX syllables in the language, a fact which is only possible if geminates syllabify in both coda and onset. See Gordon (2001) for a re-analysis of the Hausa pattern as one in which the relevant natural class of syllables is actually CVV and CVN (where N = sonorant), which would fit with my current proposal.

to place the same restrictions on isolated syllables as they do on isolated words. In an syllable elicitation task, then, speakers may tend to divide intervocalic geminates not because this reflects the real facts of syllabification in the language, but because it is awkward to pronounce a syllable-initial geminate in isolation when word-initial geminates are banned (which they are in most languages, although not all; see Muller 2001, 2002). This explanation remains, for the moment, a speculation that must be subjected to further investigation.

Now if, in accord with Resizing Theory, geminates consist of one long consonant, then they could also potentially be parsed entirely into coda position. There is some evidence that this occurs in Kukú (Cohen 2000). In this language, underlying /l/ neutralizes to glottal stop in coda position: [gbíríl-a] ‘spines’, [gbíríʔ] ‘spine’ (2000: 22).

When a geminating suffix such as the qualitative adjoins to a root-final /l/, the entire geminate shows the effects of this neutralization (2000: 5). (The examples below also show the effects of vowel harmony).

gbéʔ-ʔya	‘contribute-QUAL’
wεʔ-ʔyâ	‘smear-QUAL’
ʔyíʔ-ʔyu	‘visit-QUAL’
riʔ-ʔyû	‘yell.rudely-QUAL’

This pattern suggests that the geminate as a whole occupies coda position. It is essentially the opposite of the pattern seen in Malayalam, Latin, and Hausa, but this is not entirely unexpected, given that even intervocalic singleton consonants sometimes syllabify as codas.

If geminates consist of one long consonant, there is yet one more way in which they could conceivably be syllabified, and that is by dividing the length of the geminate

into two *unequal* portions. Such an example would provide the strongest evidence yet against the timing slot representation, which demands equal portions across syllables. I believe that Noon (Niger Congo, Senegal; Soukka 2000) possibly provides an example. In Noon, the negative perfective suffix *-i:* triggers gemination for roots that end in voiceless consonants: /ʔap/ ‘kill’ + /i:/ → [ʔappi:] ‘he has not killed’, /hot-i:/ → [hotti:] ‘he has not seen’ (2000: 46). For roots that end in implosives /ɗ,ʙ,ɟ/, however, it triggers the following changes.

/ʙeʙ/ ‘take’ + /i:/ → /ʙeʙpi:/ → [ʙewʔpi]
 /kad/ ‘leave’ + /i:/ → [kaʔti:]
 /maj/ ‘suck’ + /i:/ → /majci:/ → [majʔci:]

One interpretation of this data is that the parsing of Noon geminates into syllables occurs in a lopsided fashion, producing the somewhat puzzling data above. That is, gemination triggered by the negative perfective actually does produce a lengthened [ɗ]. But, according to the language-specific syllabification algorithm of Noon, the coda of the first syllable gets assigned relatively little of the overall length while the onset gets assigned relatively more, as depicted below.

Lengthening triggered by NEG.PERF:	ɗ	
Predicted by slot theory (symmetrical):	ɗ	ɗ
Actual (lopsided):	ʔ	t

This interpretation is supported by the following facts. First, the changes /ʙ,ɗ,ɟ/ → [wʔ, ʔ, ɟ] support the idea that some initial portion of the geminate gets parsed into the

coda, because these alternations are general in Noon codas. However, the changes /b,d, f/ → [p, t, c] do not support the idea that the remaining part of the geminate length gets parsed into a canonical onset, because these alternations are not general. Canonical onset changes would instead predict /b,d, f/ → [w, r, y], the general onset alternation in Noon. So how can we explain the presence of [p, t, c] in the surface forms? Crucially, these consonants are devoiced (and pulmonized) versions of [b,d, f]. As such, Resizing Theory analyzes them as *longer* versions of [b,d, f]. Their increased length is thus reflective of the lengthening that has applied to the root-final consonant, as triggered by the negative perfective. But the fact that they are not *as long* as the geminates [bb,dđ, ff] would be is reflective of the fact that a small portion of the geminate has already been given away to the preceding coda; what is left for the onset is [p], [t], or [c].

The examples presented above certainly do not exhaust the range of discussion that would be required to come to a conclusion regarding the syllabification of geminate consonants. But I think the examples are sufficient, at the least, to justify the stance that when geminates are parsed into separate timing units, it is not because these units play some inherent part in the geminate; rather, it is language-specific requirements of syllabification which impose this parsing.

3.4.3 Total assimilation

In a timing slot theory, geminates that result from morpheme contact have the same surface structure as those which result from total assimilation: both are “true” geminates (as opposed to “fake” geminates which result from the juxtaposition of two

identical singletons). Wolof (Niger-Congo, Senegal; Ka 1994) provides an example of gemination, triggered by morpheme contact between a root and the reversive suffix: /ub-i/ → [ubbi] ‘to open’, /teg-i/ → [teggi] ‘to remove’, /lal-i/ → lalli ‘to take off’, and so on. Korean (Sohn 1994: 469) provides an example of total assimilation, such as that triggered by liquid-nasal sequences /chil-njən/ → [chilljən] ‘seven years’. In a timing slot theory, then, the Wolof reversive would contain an empty slot in its underlying representation, /Ci/, which gets filled by feature spreading; Korean assimilation would also occur via feature spreading after de-linking.

Gemination

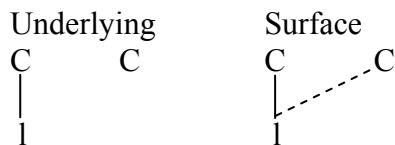

Total assimilation

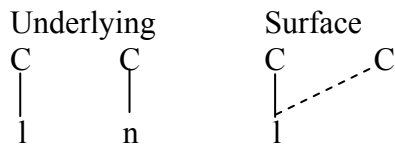

Both of these processes produce a surface structure in which segmental material is linked to two slots at once. Modulo the de-linking which must occur for total assimilation, timing slot theories thus predict that morphological gemination and total assimilation are essentially the same process.

But I do not think that this prediction is correct. There are serious differences in the cross-linguistic patterns attested for these two processes. In total assimilation, for example, the direction of spreading can change as the result of a change in the participating segments. For example, in Korean sequences containing [n] and [l],

spreading can occur in either leftward or rightward directions, depending upon the relative order of [n] and [l]: /chil-njən/ → chilljən ‘seven years’ but /pa:n-lan/ → pa:llan ‘revolt’ (Sohn 1994: 469). Boraana Oromo (Afro-Asiatic, Ethiopia) provides another example. In this language, spreading of [n] features occurs in a leftward direction for most C-[n] sequences: /did-na/ → [dinna] ‘we refuse’, /d’ugna/ → [d’unna] ‘we drink’. Just when the other consonant is a rhotic or lateral, however, spreading switches directions and we see rightward movement instead: /har-na/ → [harra], ‘we sweep’, /kofl-na/ → [kofalla] ‘we smile’ (Stroemer 1995: 24).

We do not see such reversals in morphological gemination. As in the example from Wolof, it is always the material from one particular morpheme that produces the geminate. If the grammar requires gemination of the root, gemination of the affix cannot ever serve as a substitute. By contrast, the Korean and Boraana Oromo examples demonstrate a complete insensitivity to morphological affiliation: the grammar does not care which morpheme contributes the material for the surface geminate, it only cares about its resulting segmental content.

Cross-linguistic patterns of external sandhi also highlight the difference between morphological gemination and total assimilation. Within a given language, total assimilation across word boundaries almost never occurs unless the same assimilation process occurs across tighter boundaries. In Korean, for example, total assimilation in [n] and [l] sequences takes place across word boundaries, /i:l nata/ → [i:l la.ta] ‘something happens’, but also across root-suffix boundaries as we saw above. In Hausa, total regressive assimilation in CC sequences takes place across word boundaries, /kwan

la:fiyà:/ → [kwal la:fiyà] ‘rest well’, /duk dà hakà/ → [dud dà hakà] ‘nevertheless (lit. all with thus)’, but also across root-suffix boundaries, /fit-çe:/ → fiççe ‘take out’ (gr 5 B-form), /fit dà/ → fiddà ‘take out’ (gr5 short-form) (Newman 2000: 413-414). Similar restrictions hold for total assimilation across word boundaries in Hungarian (Kenesei, Vago, and Fenyvesi 1998: 438, 440-441, 444-446) and Lango (Nilo-Saharan, Uganda; Noonan 1992: 11-12). In each case, total assimilation across a large boundary crucially must be licensed by total assimilation across a tighter boundary.

Morphological gemination is not subject to this licensing restriction. It can occur freely across word boundaries, even when the corresponding process does not occur at tighter boundaries. In Malayalam, for example, the initial consonant of the second member of a compound undergoes gemination. No corresponding process occurs across tighter boundaries.

kutti + kallji	→ kuttikkallji ‘childish game’ (Mohanam & Mohanam 1984: 588)
puucca + kutti	→ puuccakkutti ‘kitten’ (Mohanam & Mohanam 1984: 588)
pakalə + kinaawə	→ pakalkkinaawə ‘day dream’ (Mohanam 1986: 89)
maram + petti	→ marappetti ‘wooden box’ (Asher & Kumari 1997: 441)
maram + palaka	→ marappalaka ‘wooden plank’ (A& K 1997: 441)
ve am + caattam	→ ve accaattam ‘waterfall’ (A& K 1997: 441)
coodyam + kaṭalaasə	→ coodyakkaṭalaasə ‘question paper’ (A& K 1997: 441)

Morphological gemination can also occur across word boundaries in Anywa (Nilo-Saharan, Sudan; Reh 1996: 115), Japanese (Vance 1987: 148), Hungarian (Zsigiri 1994, cited in Siptár & Törkenczy 2000: 193) even when the corresponding process does not occur at tighter boundaries.

The picture that emerges is one in which total assimilation is subject to segmental factors while morphological gemination is subject to morphological factors. This justifies an approach in which morphological gemination receives an analysis of its own (here, upsizing), not one that is derivative from total assimilation.

4. Situating the scales of Resizing Theory

One of the formalisms of Resizing Theory is the scale, which imposes a linear order on the variants of a particular constituent. Scales are, of a course, a very different theoretical device than binary features (such as [\pm voice], [\pm continuant], and so on), which have been the abstract unit of choice for many phonologists. But scales are certainly not new. Scalar analyses have been proposed for sonority as far back as Jespersen (1904), and have also figured in the discussion of vowel height (e.g. Contreras 1969) and consonantal lenition and fortition (e.g. Foley 1977) (for concise overviews of earlier scalar proposals, see Gnanadesikan 1997: 6-11 and Mortensen 2006: 5-7). Recent proposals within the framework of Optimality Theory (McCarthy & Prince 1993) include Gnanadesikan (1997) on consonantal voicing scales, DeLacy (2002) on relative markedness scales, Gouskova on the sonority scale (2004), and Mortensen (2006) on tonal and vocalic scales.

4.1 Size of scalar items

Resizing Theory draws many insights from these previous proposals, but it has a couple of characteristics that make it unique. The chief such characteristic is its bird's eye view of relative size. Most previous proposals are centered around relatively small

linguistic constituents, such as individual segments and tones. Foley (1977), for example, places individual consonants along strength scales, such as $kk > k > g > \gamma$. Gnanadesikan (1997) also analyzes individual consonants, placing them along inherent voicing scales such as $t > d > n$. Mortensen (2006) analyzes individual tones, placing them along scales such as $M > H > \uparrow H$ for Dananshan Hmong (78) and $MH > LM > ML$ for Xinzhai Hmong (84). Nothing about Resizing Theory rules out such scales, but its chief characteristic of interest lies in the use of scales to impose order on larger linguistic constituents, such as entire morphemes. This is what allows us to smooth over the details of different sources of phonological alternation, and treat them as variations on the same theme.

To take a concrete example, the algorithm for scale construction in Resizing Theory is exactly the same for T^hese verb roots, which vary in the duration and voicing of their initial consonant, as it is for the Hupa perfective morpheme, which varies in the number of segments it contains.

T^hese verb root ‘plant’: $\text{ɾ}^{\text{h}}\text{ɔk}^{\text{w}}\text{ɛ} > \text{d}^{\text{h}}\text{ɔk}^{\text{w}}\text{ɛ} > \text{t}^{\text{h}}\text{ɔk}^{\text{w}}\text{ɛ}$
 Hupa perfective morpheme: $\emptyset > \{n, wi\} > win$

In both cases, the items on the scale are arranged from maximally downsized (smallest) to maximally upsized (largest). We can therefore provide a unified treatment of them, even though T^hese supposedly involves featural alternations while Hupa supposedly involves segmental ones. Scalar representations are in fact very well suited to imposing order on larger constituents that otherwise seem only haphazardly related, but to my knowledge, Resizing Theory is the first proposal to leverage this aspect of scales.

4.2 Substantiveness of scales

A second characteristic that distinguishes Resizing Theory is its focus on “substantive” ordering, to borrow a term from Mortensen (2006). It is a basic claim of Resizing Theory that linguistic constituents are ordered not arbitrarily, but according to their relative size along a particular dimension -- that is, according to their some notion of substance. Certain previous proposals, notably Foley (1977) and Mortensen (2006), argue against this position in favor of purely formal ordering. For example, Foley’s empirical focus is on consonant lenition, for which he proposes scales such as $kk > k > g > \gamma$. Crucially for Foley, the ordering on this scale has nothing to do with the features or length of the items it contains. “The concept of lenition does not refer to phonetic terms such as ‘occlusive’ or ‘spirant’ but to non-phonetic terms such as ‘strength or ‘weakness’” (1977: 29). The justification for any given ordering seems, then, to come primarily from diachrony. In Finnish, for example, historical *[kk] reduces to [k] before a genitive ending: *kirkon* ‘church-GEN.SG’, from *kirkko*. In the same environment, *[k] reduces to [g]: *kengän* ‘shoe-GEN.SG’, from **kenkän* (1977: 33). It is these types of chain shifts that underlie the scales that Foley proposes.

Mortensen’s primary empirical focus is on tone sandhi in Asian languages, although he also examines echo reduplication and ordering effects in coordinate compounds. On the basis of chain shifts that occur during sandhi, he proposes certain scales that have substantive basis, such as $M > H > \hat{H}$ for Dananshan Hmong (2006: 78). In the vocabulary of Resizing Theory, this scale is ordered according to relative size in the tone dimension; with the lowest tone (M) at one end and the highest tone (\hat{H} ,

upstepped high) at the other. Yet Mortensen also proposes other scales that have no substantive basis, such as $MH > LM > ML$ for Xinzhai Hmong (2006: 84). This scale has no ordering along any particular dimension; it is purely formal. Mortensen explicitly defends the absence of substance in such scales: “To circumscribe phonology with an arbitrary naturalness requirement would be to practice typology by fiat. Put more bluntly, it is pointless to seek the range of possible phonological grammars when the boundaries of that range are definitionally pre-determined” (91).

The difficulty with the view taken by Foley and Mortensen is, of course, that it does not place any restrictions on the types of scales we predict to find in natural language. Their approach thus conflicts with one of the primary goals of this study, which is to seek the underlying unity in processes that otherwise appear to be distinct: if any scalar ordering is possible, it becomes difficult to see this unity. In Resizing Theory, the ordering on scales *must* make reference to an independent principle. This does not mean that ordering must make direct reference to actual “substance”, i.e. variables involving motor control or acoustics. It only means that ordering must have a justification outside of the very phonological alternations it is designed to explain (see Bauer 1988, who makes a similar critique of Foley’s work). I believe that the independent principle which Resizing Theory invokes, namely relative size in a particular dimension, is at once flexible enough to encompass a reasonably wide range of phonological processes and predictive enough to say which of these processes are unified and which are distinct.

Provided, however, that the arbitrary scales proposed by Mortensen (2006) do in fact play an active role in certain individual languages, one must ask what the relationship is between these scales and those proposed in the current study. It seems

reasonable to say that scales in languages such as Xinzhai Hmong must be learned on an idiosyncratic basis; that is, such a scale cannot reasonably be considered part of human language faculty. On the other hand, the size scales discussed in this study, which are always constructed according to the same size-based algorithm, could conceivably be learned as part of a general acquisition strategy; these scales could potentially be considered part of human language faculty, if one desires to think in such terms.

4.3 The link between scales and contact

Finally, a third characteristic that distinguishes Resizing Theory from other theories is the separation of scales and contact representations. In the work of De Lacy (2002) and Gouskova (2004), these two elements are combined into a single formalism. Gouskova (2004), for example, proposes a scale in which each point contains a value representing the degree of sonority decrease or increase that occurs across the transition from a coda to an onset. This approach works well for phenomena like syllable contact, where the relationship between any two adjacent syllables will be exactly the same for any given language. But it does not extend to other types of contact. For morpheme contact, the relationship between any two adjacent morphemes need not be the same, and different contact relationships can produce different surface effects in the phonology. For this reason, Resizing Theory formally separates the representation of contact from scales, although they are linked by the fact that the shape of the former drives movement along the latter.

5. Fortition and lenition

Several, although not all, of the phonological alternations which form the empirical focus of this study have been treated under the cover terms lenition and fortition (see e.g. Escure 1977, Bauer 1988, Harris & Urua 2001, Honeybone 2001). Lenition typically includes the processes of consonant degemination, voicing, frication or approximation, and deletion. Fortition typically includes the mirror-image processes of gemination, devoicing, and occlusivization. (To my knowledge, epenthesis -- i.e., the mirror image of deletion -- is not usually included in this list. For a discussion of the historical re-analysis of rules into their mirror images, see Vennemann [1972]). Diachronically, these processes consistently recur in the same environments (Foley 1977, among others), sometimes giving rise to synchronic patterns as well, and the use of these cover terms reflects the intuition that, on some level, these processes are all the same.

Resizing Theory attempts to move beyond intuition and toward an independent principle that can unify such processes. This independent principle, relative size, predicts that degemination, voicing, and deletion should pattern together because they all downsize the length of constituents. It likewise predicts that gemination, devoicing, and epenthesis should pattern together because they all upsize the length of constituents. What Resizing Theory does *not* predict is anything having to do with frication, approximation, or occlusivization. These alternations do not, to my knowledge, exert any consistent effect on length and therefore fall outside the empirical reach of the theory (although specific fricatives have length properties that may be relevant in certain contexts; for one diachronic analysis of sibilant fricatives along these lines, see Blevins 2004b).

Insofar as individual consonant alternations are concerned, then, Resizing Theory thus takes a somewhat more narrow focus than any theory of lenition or fortition does (for an interesting proposal that specifically addresses manner of articulation in consonant lenition, see Harris & Urua 2001). Insofar as other length alternations are concerned, however, Resizing Theory takes a much broader view. It encompasses, for example, not just the deletion of an individual segment, but the deletion of two segments, three segments, or an entire morpheme, as occurs in Hupa (see Chapter 4). Likewise it encompasses not just the epenthesis of an individual segment, but the epenthesis of two or more segments, as occurs in Luganda (see Chapter 2).

Still, the concepts of fortition and lenition lurk in any discussion that includes consonant length (see Elmedlaoui 1993, Podesva 2002) and they are certainly present in the language examples used in this study. In the chapters that follow, we will see several cases where consonant voicing is accompanied by frication, or where consonant gemination is accompanied by occlusivization. In the analysis of these examples, I focus only on the changes that can be demonstrably related to relative size in the length dimension (voicing, gemination) and essentially overlook those which cannot (frication, approximation, occlusivization). This is somewhat unsatisfying, but reflects my belief that changes in manner of articulation of a single consonant must be a smaller and much more isolated phenomenon than changes in the overall size of a linguistic constituent, and that the real explanation for frication, approximation, and occlusivization will ultimately be orthogonal to the explanation for changes in length (for analyses that explicitly link length and manner, see Ohala 1997, Kirchner 2000).

6. Situating the contact relationships of Resizing Theory

The phonological literature is rich in theories of contact, and particularly in theories of morpheme contact. Very broadly speaking, these theories fall into two basic camps. Some theories emphasize the specific relationship created by two adjacent morphemes or morpheme types, and it is this relationship which triggers specific surface alternations. This notion has a long history and can be found in diverse guises (e.g., Chomsky & Halle 1986, Stanley 1973, Kiparsky 1982, Mohanan 1986, Inkelas & Zoll 2005). Other theories emphasize the location of underlying phonological material in different positions, such as root versus affix, and it is these positions which are the primary determinant of surface fate. This notion is one of the hallmarks of recent work in Optimality Theory (McCarthy & Prince 1993, Beckman 1997, Zoll 1998, Smith 2001).

Resizing Theory draws from both of these lines of thought. The chief characteristic which distinguishes it, however, is its attempt to link different morpho-phonological alternations along a cline. To see this, consider again the data from the language T^hese.

T ^h ese (Yip 2004)		
1SG.IMPF	à-rʒók ^w é	‘I plant’
1SG.PF	á-ttʒók ^w è	‘I planted’
2SG.IMPF	è-dʒók ^w è	‘you (sg) plant’

Each of the three person/aspect prefix morphemes exerts a unique effect: reduction to flap, gemination, and voicing. And most theories would thereby offer a unique analysis for each instance of contact, separating them into distinct boundaries (Chomsky & Halle 1968, Stanley 1973), distinct levels of rule application (Kiparsky 1982, Mohanan 1986),

or distinct co-phonologies (Inkelas & Zoll 2007). But something is missing here: even though the person/aspect morphemes do exert unique effects, these effects crucially share certain traits. Each targets the initial consonant of the root. An each can be described as a change in length: reduction to flap, as in the 1SG.IMPF, shortens the target consonant while gemination and devoicing, as in the 1SG.PF, lengthens it. A theory of phonology should treat these common traits not as random or accidental, but as the direct consequence of the type of contact relationship that obtains in each case. Resizing Theory, in which contact relationships of different strengths trigger concomitant changes in relative size, attempts to do just that.

Chapter 2: Phonological alternations in the service of higher effects

1. Introduction

According to Resizing Theory, contact relationships drive surface changes in the relative size of linguistic constituents. Specifically in this study, which pays special attention to morpho-phonemic length alternations, contact relationships between morphemes drive surface changes in length. Relationships are realized either by upsizing the morpheme on the stronger side of the boundary, or downsizing the morpheme on the weaker side. Independent phonological constraints can, however, shape *how* these relationships are realized in particular contexts, such that the same morphological relationship takes on a diverse surface forms. Resizing Theory predicts that, crucially, such surface forms must be unified by the fact that they all upsize (downsize) a particular morpheme.

We predict, for example, that the downsizing alternation of voicing can serve the same morphological role as other downsizing alternations such as deletion or degemination. Such a pattern is exemplified by Turkish, where noun roots undergo either devoicing of the root-final consonant, or deletion of /k/, similar to what occurs in Pāri

Turkish (Inkelas & Orgun 1995; Pycha, Inkelas & Sprouse 2007)

/kanat-a/	→ [kanada]	‘wing-DAT’
/bebek-e/	→ [bebee]	‘baby-DAT’

In the same vein, we predict that the upsizing alternation of devoicing can serve the same morphological role as other upsizing alternations like epenthesis or gemination. Such a pattern is exemplified by Northern Sotho, where Class 9/10 nouns are marked either by

the devoicing of the root-initial consonant, or by the epenthesis of /k/ (Poulos & Louwrens 1994: 456-457).

Northern Sotho:	/-bal/	→ [palô]	‘number’
	/-ilêl-/	→ [kilêlô]	‘a taboo’

What Resizing Theory rules out are cases in which a single morphological effect is achieved by a set of alternations that sometimes upsize a morpheme and sometimes downsize it. In other words, devoicing should not pattern with deletion or degemination. Voicing should not pattern with epenthesis or gemination.

Occasionally, however, independent constraints may impede the upsizing of the stronger morpheme (or downsizing of a weaker morpheme), thereby threatening the surface realization of the contact relationship. In these cases, the theory predicts *compensatory downsizing* of the weaker morpheme (or upsizing of the stronger). Thus, we predict that upsizing and downsizing alternations can conspire to achieve the same morphological effect, but only if these alternations target opposing morphemes in the contact relationship. Such a pattern is exemplified by Meithei (Chelliah 1997), where the Non-Hypothetical suffix *-i* triggers upsizing of the root via gemination of the final consonant. When the root is vowel-final, however, downsizing of the suffix occurs instead, via glide formation.

/tʃél-i/	→ tʃéllí	‘runs’
/ú-í/	→ új	‘sees’

Another major prediction of Resizing Theory is that contact relationships exist along cline of heights. These, in turn, are reflected by a cline of sizes in the surface variants of a particular element. This prediction is borne out in T^hese (Nilo-Saharan,

Sudan; Yip 2004, discussed more fully in Chapter 2), where the contact relationships between verb root morphemes and person/aspect morphemes exist along a cline, reflected by differences in the length of the initial consonant of the root:

[à-ɾókwé] ‘I plant’ (shortest)
[è-ɖókwé] ‘you plant’
[á-ɬókwé] ‘I planted’ (longest)

The goal of this chapter is to examine the cross-linguistic evidence in support of these predictions. Turkish, for example, exhibits a downsizing pattern quite similar to what we saw in Pári, and a Resizing Theory analysis shows how the morpheme contact relationship responsible for downsizing extends a wide variety of apparently unrelated alternations (§2). Northern Sotho exhibits a mirror-image upsizing pattern, demonstrating, among other things, that historically-based accounts of velar lenition are not synchronically sufficient (§3). With these two extended examples under our belt, we are ready to reanalyze “total assimilation” in Hungarian as an instance of gemination and epenthesis acting in concert (§4), and to tackle cases in which multiple segments, not just single segments, are epenthesized as in Luganda and Choctaw (§5). I then take a closer look at the phenomenon of compensatory resizing, using Meithei and Ibibio as examples (§6). Finally, I offer an analysis of the clines of contact relationships in T^hese (§7).

2. Downsizing in Turkish

In our discussion of Pári in Chapter 1, we examined how Resizing Theory unifies consonant voicing and consonant deletion as a single scalar movement. Turkish exhibits a similar set of facts, which have been analyzed by many previous researchers (e.g. Lees

1961, Comrie 1997, Kaisse 1986, Rice 1990, Inkelas & Orgun 1995, Kibre 1999, Wedel 2002, Pycha, Inkelas & Sprouse 2007). Examples and page numbers are from Inkelas & Orgun (1995), unless otherwise noted.

Nominative	Third possessive		
kalutp	kalutb-ut	‘mold’	776
kanat	kanad-ut	‘wing’	776
gyvetʃ	gyvedʒ-i	‘clay pot’	776
bebek	bebe-i	‘baby’	767

As the data shows, the root-final stop and affricates [p, t, tʃ] are voiceless word-finally, but voiced before the third possessive suffix *-I*. In parallel, the root-final velar surfaces word-finally, but deletes before the suffix.

In this section, I will show that an analysis in Resizing Theory can unify the facts of voicing and deletion for Turkish just as it does for Pāri. A special focus on Turkish is of particular interest, though, for two reasons. The first is that the analysis extends directly to other alternations, such as the consonant epenthesis that occurs when suffixes such as the third possessive */-I/* or the accusative */-I/* combine with a vowel-final root such as *korku* ‘fear’ (compare with a lack of epenthesis in *el* ‘hand’).

Nominative	Third possessive	Accusative		
el	el-i	el-i	‘hand’	Lewis 1967: 29, 39
korku	korku-su	korku-ju	‘fear’	Lewis 1967: 31, 39

Furthermore, the analysis extends to the *failure* of alternations in certain cases, such as the resistance of suffix-initial velars to deletion. For example, the initial velar in the adverbial auxiliary *-ken* ‘while doing/being’ does not delete when it combines with a

vowel-final root such as *hasta* ‘sick’ (compare with *jorgun* ‘tired’); instead, the velar is retained and a glide [j] is epenthesized.

Root	Adverbial auxiliary		
jorgun	jorgun-ken	‘while being tired’	Underhill 1976: 400
hasta	hasta-jken	‘while being sick’	Underhill 1976: 400

My basic claim is that all of these alternations result from a single morpheme contact relationship, whereby roots are weaker than suffixes. For consonant-final roots, this relationship drives root downsizing via voicing and deletion, just as in Pãri; for vowel-final roots, however, the same relationship drives suffix upsizing via epenthesis, as we saw occurring in the third possessive, accusative, and adverbial auxiliary. Viewing the data in this way also provides a simple explanation for a well-known case of opacity. In Turkish, phonological vowel hiatus seems to be generally repaired via glide epenthesis, *except* when velar deletion has applied first (as in /bebek-i/ → [bebei], *[bebeji]). Under Resizing Theory, however, velar deletion fully satisfies the requirements of the morpheme contact relationship, obviating the need for epenthesis, which is viewed as a morphological operation, not a phonological one.

Another reason to pursue an analysis of Turkish is that previous treatments of its phenomena have been almost exclusively syllable-based, and therefore cast within primarily or exclusively phonological terms. Viewing the same facts within Resizing Theory highlights the fact that, while several phonological constraints are indeed at play, it is morphological factors which are the driving force behind the Turkish patterns.

2.1 Basic analysis of Turkish

At the heart of Resizing Theory's approach to Turkish is the following morpheme contact relationship.

Roots < Suffixes

“The boundary between roots and suffixes requires a relative weakening on its left side and/or a relative strengthening on its right. Edges only.”

As we will in more detail below, it is only certain classes of root and suffix morphemes which enter into this relationship, and it is this fact which provides us with an initial justification for treating the Turkish data as a morphological pattern, not a phonological one. Thus, words such as [kanad-tu] ‘wing-ACC’ represent instances in which a member of the “weaker root” class combines with a member of the “stronger suffix” class. Such words are subject to the above contact relationship, which I will refer to as the Weaker-Stronger relationship. But when a root or suffix in a word is not a member of the relevant morpheme class, the Weaker-Stronger relationship does not hold. For example, in a word such as [anit-i] ‘monument-ACC’, the root-final stop resists voicing. Under the analysis presented here, this is for morphological reasons; /anit/ is not a member of the weaker root class and therefore has no reason to downsize. Note that the division of Turkish words into two classes, those which are subject to the Weaker-Stronger relationship and those which are not, makes the broad prediction, which we will see borne out in subsequent sections, that we should never see downsizing effects in suffixes.

The Weaker-Stronger relationship is responsible for a range of effects because there are two possible ways in which its requirements can be met: either by downsizing the edge of the root morpheme or by upsizing the edge of the suffix morpheme. For stop-

final roots, Turkish pursues the first option while for vowel-final roots, it pursues the second option. Let us examine the scales for stop-final roots where, for non-velars, downsizing means a one-point movement on the scale, resulting in voicing of the stop.

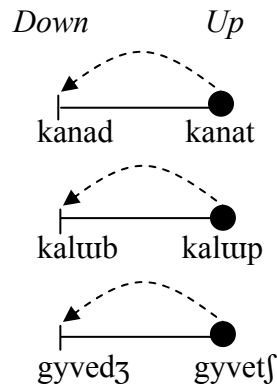

For velars, downsizing also means a one-point movement on the scale, and here the result is deletion.

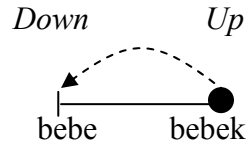

Notice that the STARTING POINT for scalar movement in non-velar roots, indicated by the black circle in each scale, is always the voiceless-stop variant ([kanat], [kaltup], [gyvetʃ]). This is in line with the definition of a starting point in Resizing Theory: it is the variant which would occur when *no* contact relationship is operative. Since the nominative (isolation) forms require no suffix morpheme and hence have no operative contact relationship, and since voiceless stop variants occur here, it is these variants that I have designated as starting points. This contradicts previous analyses which have proposed that the underlying form for the stops in such words is either [+voice] (Kaisse

1986, Rice 1990), a view which has since been disconfirmed, or underspecified for [voice] (Inkelas & Orgun 1995), a view which still holds weight. Recall from the discussion of starting points in Chapter 1 that they may differ from underlying forms. Still, treating the voiceless stops as more basic represents the first step in unifying voicing with velar deletion. Words such as *bebek* ‘baby’ must have /k/ in their underlying form; it would be intuitively very difficult to believe, and theoretically perhaps impossible to implement, that such words are underspecified for the presence or absence of [k]. Non-velar stops are voiceless in the environments corresponding to the presence of [k], therefore, it makes sense to consider them as basic.

Our analysis thus far should look familiar from Pāri, and bears out the prediction of Resizing Theory that voicing and deletion should pattern together. The Turkish facts become more interesting, however, when we consider what happens to vowel-final roots when they combine with vowel-initial suffixes. As we saw above, epenthesis adds a consonant to these suffixes, [s] for the third possessive and [j] for the accusative (as well as other suffixes, such as the dative).

Third possessive

/korku-u/ → [korku-su] ‘fear-3POSS’

cf. [eli] ‘hand-3POSS’, [akʃamtu] ‘evening-3POSS’ (Lewis 1967: 39)

Accusative

/korku-u/ → [korku-ju] ‘fear-ACC’

cf. [eli] ‘hand-ACC’, [akʃamtu] ‘evening-ACC’ (Lewis 1967: 29-30)

Initially, this situation looks like vanilla epenthesis that occurs in order to repair an undesirable phonological situation, namely vowel hiatus. But there are several reasons to question this view. First, while there is a “default” epenthetic segment [j] which occurs

with most vowel-initial suffixes, it does not occur with all of them: the third possessive has its own epenthetic segment, [s], suggesting the need to bring morphological conditioning into the picture. Second, Turkish permits many cases of surface vowel hiatus, as we saw in words like [bebe-i] ‘baby-ACC’, suggesting that the phonology does not actually require a repair. And finally, epenthesis of [j] is not limited to situations of vowel hiatus, but also occurs with certain consonant-initial suffixes such as *-ken*, cf. [hasta-jken] ‘while being sick’, suggesting that the domain of epenthesis reaches beyond vowel hiatus.

On these bases, I suggest that epenthesis of [s] and [j] is actually a morphological operation. That is, epenthesis is a means for suffixes to undergo upsizing, and therefore to meet the requirements of the Weaker-Stronger contact relationship. This is an example of COMPENSATORY RESIZING, whereby upsizing and downsizing can conspire to achieve the same morphological effect, but *only* if these alternations target opposing constituents in the contact relationship. In this case, just when a Turkish root fails to meet the grammatical requirement to manifest the contract relationship via upsizing, the suffix steps in and manifests it via downsizing.

The Weaker-Stronger relationship triggers movements on the size scales for the third possessive and accusative which are shown, respectively, below.

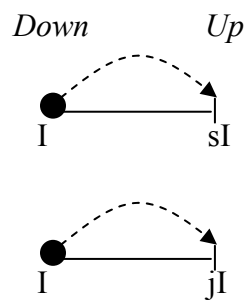

Now consider what happens to velar consonants in suffix-initial position.

Interestingly, these are *always* immune to deletion in Turkish, a troubling observation for those previous analyses which have proposed that it is crucially an intervocalic environment which triggers deletion (Lees 1961, Inkelas & Orgun 1995). For example, the initial velar in the adverbial auxiliary *-ken* ‘while doing/being’ does not delete but instead epenthesizes [j].

Adverbial auxiliary

/hasta-ken/ → [hasta-jken]

cf. [jorgun-ken] ‘while being tired’, [asker-ken] ‘while being a soldier’

Under the Resizing Theory analysis, there is nothing exceptional about the failure of velar deletion in this case. Velar deletion is a downsizing relationship and therefore not predicted to occur on suffixes which are, according to the Weaker-Stronger relationship, strong relative to roots.

Viewing epenthesis in this way also helps us to take a fresh look at an old case of opacity. If we consider [j]-epenthesis to be a general process that takes place to avoid vowel hiatus, surface opacity seems to occur in cases of velar deletion, which create vowel hiatus. In a serial theory of rule ordering, opacity can therefore occur when glide epenthesis precedes velar deletion, in a bleeding order.

Underlying form:	/bebek-i/	
Glide epenthesis:	---	
Velar deletion:	bebei	
Output:	[bebei]	*[bebeji]

Under Resizing Theory, opacity is not an operative concept. When a root such as /bebek/ combines with a suffix such as the accusative /-I/, it is the morpheme contact relationship, not phonological constraints, which governs the action at the boundary. Velar deletion meets the requirements of this contact relationship, so no further alternations are predicted to occur. In other words, glide epenthesis is not a general repair for vowel hiatus; instead, it is a morphological operation that is called upon only as needed to manifest contact relationships; when not needed, it does not occur.

2.2 Nature and scope of the Turkish patterns

The data shown above, while accurate, represents a simplification of the Turkish facts. In this section I present the patterns of the language in more detail, with an eye toward highlighting some of the differences between past approaches and the current one. The examples are drawn from Inkelas & Orgun (1995), except where noted. Their analysis, which makes extensive use of syllable structure and minimal size restrictions, differs significantly from the current one, where these phonological considerations play a minimal role. Yet Inkelas & Orgun base their phonological considerations within a full-fledged theory of morphological conditioning (perhaps best characterized as a successor to lexical phonology); this makes it similar in spirit, if not in details, to the Resizing Theory analysis, so I will point out comparisons between the two analyses as I present the relevant data.

Turkish (see Lewis 1967 for an overview) has the following consonants: [p, t, k, tʃ, f, s, ʃ, b, d, g, dʒ, v, z, ʒ, m, n, l, r, j, h] and the following vowels [i, y, u, u, e, ø, o, a].

Words are formed almost entirely by agglutinating suffixation. Roots may be

monosyllabic or polysyllabic, and may begin or end in either a consonant or a vowel. Roots may also end in consonant clusters; those which form licit syllable codas may surface in this position (e.g. [dørt] ‘four’) while those which form illicit codas undergo epenthesis (e.g. /fikr/ → [fikir] ‘idea’). Suffixes may begin or end in either a consonant or a vowel. Harmony spreads progressively from roots to most suffixes; front-back harmony targets all vowels while rounding harmony targets high vowels only.

2.2.1 Turkish voicing

At first glance, the voicing behavior of Turkish consonants seems to be attributable to a process of coda-final devoicing, similar to that found in German or Russian. Thus, the analysis put forth by several researchers (Lees 1961, Kaisse 1986, Rice 1990) is that the final stop in a word like *kanat* ‘wing’ is underlyingly voiced, /kanad/, but that it undergoes obligatory devoicing in word-final position. One appeal of this proposal is that it readily generalizes to syllable-final position, an environment created with the addition of a consonant-initial suffix such as plural *-lar* or ablative *-ten*.

Nominative	Plural	Ablative		
kanat	kanat-lar	kanat-tan	‘wing’	776
kaltup	kaltup-lar	kaltup-tan	‘mold’	776
gyvetŧ	gyvetŧ-ler	gyvetŧ-ten	‘clay pot’	776

Another appeal of this proposal is that it also generalizes to the prevocalic environments created by other suffixes, such as the dative *-e*.

Nominative	Dative		
kanat	kanad-a	‘wing’	776
kaltup	kaltub-a	‘mold’	776
gyvetʃ	gyvedʒ-e	‘clay pot’	776

The root-final consonant alternations for the dative are identical to those which occur in the accusative, and that is precisely the point. The idea is that, in the environment created by a vowel-initial suffix, the root-final consonants syllabify as onsets and their underlying [+voice] specifications are therefore permitted surface.

Such an analysis can also handle final stops in CVCC roots.

Nominative	Third possessive	Plural		
dørt	dørd-y	dørt-ler	‘four’	779
hartʃ	hardʒ-ur	hartʃ-lar	‘mixed ingredients’	779
harp	harb-i	harp-ler	‘war’	779
tatʃ	ta:dʒ-ur	tatʃ-lar	‘crown’	779

Again, the vowel-initial suffix (here the third possessive) permits the root-final consonant to syllabify as an onset, where the [+voice] feature surfaces without neutralization.

As Inkelas & Orgun (1995) point out, however, the comparison with German and Russian is not entirely felicitous because not every Turkish root follows the pattern of final devoicing (see also Comrie 1997: 892). In addition to roots which are underlyingly voiceless, Turkish also has roots which are underlyingly voiced but resist the devoicing process.

Nominative	Accusative		
devlet	develet-i	‘state’	777
anıt	anıt-i	‘monument’	777
etüd	etüd-y	‘study’	777
jeolog	zeolo-u	‘geologist’	777

These so-called exceptions are, in fact, a full-fledged alternative pattern within the language. Using a “living” lexicon of Turkish compiled from a single speaker, Pycha, Inkelas & Sprouse showed that only 52% of polysyllabic nouns undergo the voicing alternation; the rest have final stops which are either consistently voiceless or consistently voiced (see also Wedel 2002). In other words, fully 48% of the noun roots in the language fall into the same class as [devlet] ‘state’ and [etyd] ‘study’.

The heterogeneous nature of the data casts doubt on a purely syllable-based analysis, and introduces a morphological component into the picture. Inkelas & Orgun propose that the language has an underlying, three-way contrast in voicing. Roots may have consonants that are underlyingly [+voice] ([etyd] ‘study’), underlyingly [-voice] ([devlet] ‘state’), or underlyingly unspecified for voice ([kanat] ‘wing’). In these latter cases, the grammar fills in a voicing specification based on syllable structure: when the consonant is in coda position, the grammar assigns [-voice]; when it is in onset position, the grammar assigns [+voice].

Thus, what looks like a syllable-based alternation is also (or instead) a morpheme-based one, because its operation depends upon the particular root in question. The analysis that I develop follows Inkelas & Orgun (1995) in creating a fundamental division among the roots in Turkish, but I recast this as a two-way division between plain root morphemes and weaker root morphemes. Plain morphemes, such as [devlet] and [etyd], may have voiceless or voiced final consonants, but this is not particularly important; their defining characteristic is that they do not participate in the Weaker-Stronger relationship. Weaker roots, such as [kanat], crucially form part of the class of roots that do participate in this relationship.

It has been suggested that monosyllabic Turkish roots, as a class, do not alternate in voice (Lewis 1967: 11, Wedel 2002). It is true that monosyllables exhibit a tendency toward non-alternation; Pycha, Inkelas & Sprouse found that 83% of monosyllabic noun roots with final stops do not alternate. Still, all three voicing patterns are robustly attested, just as they are for the polysyllabic roots.

Nominative	Third possessive		
gyc	gyc-y	‘power’	787
kap	kab-uu	‘container’	787
satʃ	sadʒ-uu	‘sheet steel’	787
dʒep	dʒeb-i	‘pocket’	787
Nominative	Accusative		
at	at-uu	‘horse’	778
sap	sap-uu	‘stem’	778
kotʃ	kotʃ-u	‘ram’	778
Nominative	Plural		
ad	ad-lar	‘name’	779
id	id-ler	‘id’	779
lig	lig-ler	‘league’	779
ødʒ	ødʒ-ler	‘revenge’	779
ød	ød-ler	‘gall’	779
ud	ud-lar	‘oud’	779

Inkelas & Orgun (1995) propose that the tendency for monosyllabic roots not to alternate derives from their small size. A bi-moraic minimal size condition forces the final consonant to syllabify at the root level, where it is assigned a [-voice] specification that subsequent re-syllabification cannot alter. Exceptions to this tendency are attributed to lexical pre-specification of the [voice] feature.

A final point regarding the voicing pattern concerns roots of the shape CVCC. When these roots combine with a vowel-initial suffix, such as the accusative, the final CC

sequence syllabifies as a coda followed by an onset. But when no suffix is added, as in the nominative case, the root-final CC forms an illicit coda cluster, and a high vowel is epenthesized between them.

UR	Accusative	Nominative		
/hadʒm/	hadʒ.m-i	ha.dʒim	‘volume’	780
/dʒebr/	dʒeb.r-i	dʒebir	‘algebra’	780
/sabr/	sab.ru	sabur	‘patience’	780
/kutr/	kut.r-u	ku.tur	‘diameter’	780
/metn/	met.n-i	me.tin	‘text’	780
/haps/	hap.s-i	ha.pis	‘prison’	780

Interestingly, as shown by the data above, the intervocalic environment created by vowel epenthesis never triggers a voicing alternation. The root-internal stops remain either always voiced, or always voiceless. Inkelas & Orgun attribute this to the fact that the target stops undergo an early round of syllabification, during which they are placed in the coda (e.g., kut.[r], where the final consonant is extra-prosodic) and therefore are assigned [-voice] if they have no voicing value already. Subsequent re-syllabification does not alter this feature specification.

2.2.2 Turkish velar deletion

The pattern of velar deletion is widespread in Turkish; further examples are given below.

bebek	‘baby’	bebe-i	‘baby-3POSS’	767
oluk-tan	‘gutter-ABL’	olu-u	‘gutter-ACC’	767
salak-lar	‘stupid-3PL’ (= ‘they are stupid’)	sala-im	‘stupid-1SG’ (= ‘I am stupid’)	767
katalog	‘catalog’	katalo-u	‘catalog-3POSS’	767
jeolog-dan	‘geologist’	jeolo-u	‘geologist-ACC’	768

gel-edzek- ler-i	‘com-FUT-PL-3POSS’ (= ‘that they will come’)	gel-edʒe-im	‘come-Fut-1sg.Poss’ (= ‘that I will come’)	768
gør-dyk-ler-i	‘see-PPL-PL-3POSS’ (= ‘those that (s)he saw’)	gør-dy-y	‘see-PPL-3POSS’ (= ‘the one that (s)he saw’)	768

Inkelas & Orgun (1995) adopt a syllable-based analysis of velar deletion, proposing a constraint *VGV which prohibits intervocalic velar onsets. Any velar which would potentially wind up in a surface onset undergoes deletion instead. As with the voicing alternation, however, there are root-based exceptions to this pattern.

Nominative	Dative		
almanak	almanak-a	‘almanac’	Pycha, Inkelas & Sprouse (2007: 371)
sinagog	sinagog-a	‘synagogue’	Pycha, Inkelas & Sprouse (2007: 371)

Such exceptions, while well-attested, are not as prolific as exceptions to voicing. Pycha, Inkelas & Sprouse (2007) reported that 93% of polysyllabic velar-final noun roots exhibit deletion. In other words, the data above represent a sub-pattern that holds for about 7% of velar-final nouns.

In monosyllabic roots, there is a tendency toward non-alternation, but this is not absolute; roots which resist deletion and undergo it are both attested.

køk	‘root’	køk-e	‘root-DAT’	*køe	774
ek	‘affix’	ek-i	‘affix-ACC’	*ei	774
ok	‘arrow’	ok-um	‘arrow-1sg.POSS’	*oum	774
lig	‘league’	lig-i	‘league-3POSS’	*lii	774
fyg	‘fugue’	fyg-e	‘fugue-DAT’	*fye	774
tʃok	‘many’	tʃo-u	‘many-3POSS’		788
gøk	‘sky’	gø-y	‘sky-ACC’		788

Pycha, Inkelas & Sprouse (2007) report that 8% of monosyllabic velar-final roots exhibit deletion. It appears, then, that the split between monosyllables and polysyllables is stronger for velar deletion than for voicing, and Zimmer & Abbott (1978) offer

psycholinguistic evidence to support the idea that the division between the root sizes is a productive one for speakers.

But an interesting twist on velar deletion is that, in addition to certain root morphemes which resist it, there are certain suffix morphemes which resist it as well. These include the imperfect, relative, future, adjectival, adverbial, and nominal suffixes.

gedzik-ir	*gedziir	‘be late-IMPF’	768
birik-en	*birien	‘accumulate-REL’	768
birak-adzak	*biraadzak	‘release-FUT’	768
meslek-i:	*meslei:	‘profession-Adj’ (= ‘professional’)	768
na:zik-en	*na:zien	‘kind-ADV’ (= ‘kindly’)	768
elastik-iyet	*elastiiyet	‘elastic-NML’ (= ‘elasticity’)	768

A search of the Turkish Electronic Living Lexicon (TELL; Inkelas et al. 2000) confirms that it is the suffixes in the examples above, and not the roots, which resist deletion. For example, the root [meslek] ‘profession’ undergoes velar deletion when it combines with the accusative [meslei], the third possessive [meslei], and the first person predicative [mesleim]. Resistance to velar deletion in a word like [meslek-i:] thus arises from the class that the particular suffix belongs to, and has nothing to do with the root per se.

Interestingly, all three velar-initial suffixes in Turkish also fall into the class of morphemes that resist velar deletion. These include *-ken*, whose behavior we have already examined briefly, as well as *-gen*, a derivational suffix which creates a polygon from a numerical base and *-ki*, a relativizer.

Polygon suffix <i>-gen</i>				
Number		Polygon		
altuu	‘six’	altuu-gen	‘hexagon’	769 fn. 5
on-iki	‘twelve’	on-iki-gen	‘dodecagon’	769 fn. 5
Relativizer suffix <i>-ki</i>				
ʃimdi-ki-ler		‘the ones that are current’		769 fn. 5 (from Underhill 1976: 212)
now-REL-PL				
køj-de-ki-ler		‘the ones in the village’		769 fn. 5 (from Underhill 1976: 212)
village-LOC-REL-PL				
køʃe-de-ki-nin-ki		‘the one of the one in the corner’		769 fn. 5 (from Swift 1963: 139)
corner-LOC-REL-GEN-REL				

As with voicing, then, what looks like a syllable-based alternation is also (or instead) a morpheme-based one -- this is particularly clear in the case of velar deletion because its operation depends not just upon the particular root in question, as for voicing, but also upon the particular suffix in question. Inkelas & Orgun (1995) address all three of the velar-initial suffixes in a footnote (768-769, fn 5). They argue that *-gen* attaches at Level 2, where velar deletion is not enforced; this is the same level where the imperfect, relative, and other deletion-resistant suffixes attach. For *-ken*, the appearance of a glide-initial variant simply means that the intervocalic environment required for velar deletion is not met. And for *-ki*, there is no straightforward way to determine what level it attaches to, and therefore no way to determine if velar deletion should or should not apply in this instance.

Just as roots with the shape CVCC resist voicing under epenthesis, so do roots with the shape CVkC resist velar deletion.

UR	Accusative	Nominative		
/akl/	ak.l-ur	a.kur	‘intelligence’	776
/aks/	ak.s-i	a.kis	‘reflection’	776
/fikt/	fik.r-i	fi.kir	‘idea’	776
/hykm/	hyk.m-y	hy.kym	‘judgment’	776
/nakt/	nak.t-i	nakit	‘cash’	776
/ʃekl/	ʃek.l-i	ʃekil	‘shape’	776
/ʃykr/	ʃyk.r-y	ʃykyr	‘gratitude’	776

The issue here is that vowel epenthesis creates an intervocalic environment, which is supposedly a trigger for velar deletion, yet deletion does not occur. Inkelas & Orgun attribute the behavior of these roots to the fact that the target velars undergo an early round of syllabification, during which they are placed in the coda (e.g., ak.[l], where the final consonant is extra-prosodic). The very fact of early syllabification does the trick, even if the structure of syllabification changes later on: “Once syllabified, the velar is permanently immune to deletion, even in case epenthesis and re-syllabification at later levels render it an intervocalic onset” (1995: 776).

Finally, we should note the behavior of CVCK roots before a vocalic suffix, where the velar undergoes voicing (just as other stops do) but not deletion.

Nominative	Third possessive	Plural		
rejk	reng-i	rejk-ler	‘color’	779

2.3 Proposal of Inkelas & Orgun (1995)

As should be clear from the above discussion, the analysis of Inkelas & Orgun (1995) rests on three primary ideas: 1) the invisibility of final consonants for purposes of syllabification, 2) minimal size conditions which can syllabify these otherwise invisible consonants, and 3) syllabification as a form of “pre-specification.” Taken together, these three ideas predict the tendency for small (monosyllabic) roots to resist voicing and velar

deletion, because minimal size conditions require that their final consonants syllabify early, where they receive specifications for voicing or, in the case of velars, become immune to deletion even if subsequent syllabification occurs. In addition, the four morpho-phonological levels of Turkish may each impose different requirements; at Level 2, for example, the constraint against velars in onsets does not hold, although it does at subsequent levels. To support their claims, Inkelas & Orgun (1995) offer evidence for minimal size conditions in the language, as well as data from suspended affixation, which I have not presented here.

The analysis of Inkelas & Orgun (1995) thus differs significantly from the one that I advocate here. In particular, the treatment of so-called exceptions is very different. Inkelas & Orgun (1995) take it upon themselves to explain the apparent tendency of short roots to resist voicing and velar deletion, which then requires that they offer a separate explanation for the exceptions to this tendency (viz., pre-specification, either of features or of morpho-phonological levels). In my Resizing Theory approach, I take the exceptions-to-the-tendency as a sign that the tendency itself does not warrant a separate analysis. This simplifies matters insofar as there now exist only two types of Turkish words, those which are subject to the Weaker-Stronger relationships and those which are not. Still, it complicates matters insofar as there seems to be some phonological constraints, such as the fact that almost all of the action requires an intervocalic environment, which remain unaccounted for. It is to these constraints that I turn next.

2.4 Re-thinking the intervocalic constraint

Phonological constraints appear to be active in the alternations discussed above, particular with regards to the segmental make-up of the suffix morpheme. The generalization seems to be one about intervocalic environments. When the suffix is vowel-initial, all of the alternations (voicing or velar deletion of the root; [s] and [j] epenthesis of the suffix) are in evidence. When the suffix is consonant-initial, however, no alternations are in evidence and the morphemes simply concatenate without further changes.

V-initial suffix		C-initial suffix			
olu-u	‘gutter-ACC’	oluk-tan	*olu-tan	‘gutter-ABL’	767
kanad-a	‘wing-DAT’	kanat-lar	*kanad-lar	‘wing-PL’	776
korku-su	‘fear-ACC’	korku-lar	*korku-slar	‘fear-PL’	

Such observations have informed analyses in which the trigger for voicing and deletion is characterized as an intervocalic environment (see works cited above). If Resizing Theory is going to claim that the driving force behind the alternations is not intervocalic position, but a relationship that holds between root and suffix morphemes, it must somehow confront the fact that the realization of this relationship is phonologically blocked in a large number of contexts in which it would be expected, from a morphological point of view, to occur.

We have already seen a number of exceptions to the generalization that an intervocalic environment triggers these changes. The exceptions can be root-based, which formed the primary justification for characterizing the data as morphological in the first place. Thus, [anit], [etyd], and [almanak] are all roots that resist change, cf. [anit-i] ‘monument-Acc’, [etyd-y] ‘study-Acc’, [almanak-a] ‘almanac-DAT’. As the data from the

lexicon study by Pycha, Inkelas & Sprouse (2007) showed, these exceptional roots are not alone; they constitute a full-fledged alternative pattern within the language.

The exceptions can also be suffix-based. For example, the adjectival suffix *-i:* fails to trigger velar deletion despite an intervocalic environment, [meslek-i:] ‘professional’. Although the adjectival suffix may be in the minority, it is certainly not alone. Several other suffixes behave similarly. The relevant examples are repeated again here for convenience.

gedzik-ir	*gedziir	‘be late-IMPF’	768
birik-en	*birien	‘accumulate-REL’	768
birak-adzak	*biraadzak	‘release-FUT’	768
meslek-i:	*meslei:	‘profession-Adj’ (= ‘professional’)	768
na:zik-en	*na:zien	‘kind-ADV’ (= ‘kindly’)	768
elastik-iyet	*elastiiyet	‘elastic-NML’ (= ‘elasticity’)	768

Furthermore, there are consonant-initial suffixes which *do* trigger alternations. For example, although the plural *-ler* triggers no alternation when it combines with a root [hasta-lar] ‘the sick ones’, the adverbial auxiliary *-ken* does [hasta-jken] ‘while being sick’. Again, although the adverbial auxiliary may be in the minority, but it is certainly not alone. The past tense *-di* also behaves this way and epenthesizes a glide [hasta-jdu] ‘s/he was sick’.

The proliferation of exceptions suggests that the correct generalization is not a phonological one at all, but a morphological one. We already saw that the set of roots which participate in the relationship “Roots < Suffixes” is arbitrary, and must therefore be designated as a morphological class. We have amassed sufficient evidence to say that the

set of suffixes which participate in this relationship is arbitrary, too. It so happens that most of these suffixes are vowel-initial, giving the impression of a phonologically regular process. But some of these suffixes are consonant-initial, and other vowel-initial suffixes are excluded. This is arbitrariness, the hallmark of a truly morphological process.

2.5 Rethinking phonologically epenthetic vowels

Another phonological constraint that seemed to be active in the data concerned CVCC roots. As we saw above, when such roots occur in isolation (as in the nominative) or before a consonant-initial suffix, phonological epenthesis of a high vowel *-I* occurs to repair the unsyllabifiable coda cluster (this is distinguished from upsizing epenthesis, which I have argued occurs for strictly morphological reasons). The intervocalic environment created by epenthesis, however, fails to trigger alternations. Relevant examples are repeated below.

UR	Accusative	Nominative		
/kutr/	kut.r-u	ku.tur	‘diameter’	780
/akl/	ak.l-tu	a.ktu	‘intelligence’	776

Under Resizing Theory, this is a natural consequence of the fact that the stop consonants in question never occupied the edge of the root morpheme to begin with. The contact relationship for Turkish is restricted to morpheme edges only; its width does not overlap at all with the internal structure of the morphemes on either side of it. The intervocalic environment created by phonological epenthesis is of no consequence, because Resizing Theory does not consider it to be a triggering environment.

2.6 Rethinking suffix-initial velars

Recall that there are three velar-initial suffixes in Turkish: the polygon-forming *-gen* [altu-gen] ‘hexagon’, the relativizer *-ki* [ʃimdi-ki] ‘the current one’, and the adverbial auxiliary *-ken* [hasta-jken] ‘while being sick’. The failure of these velars to delete in all three cases, despite the intervocalic environment they find themselves in, is an important generalization, and it is one which falls out naturally from the Resizing Theory analysis. This analysis posits that there are essentially two ways for morphemes in Turkish to combine: via the Weaker-Stronger contact relationship (which triggers upsizing and downsizing in length) or via no contact relationship at all (which does not).

We therefore predict that velar-initial suffixes can either upsize or undergo no change at all, and this is exactly the range of patterns that we see. The suffix *-ken* participates in the Weaker-Stronger relationship, and realizes it with upsizing via epenthesis. The other two suffixes, *-ki* and *-gen*, do not participate in any relationship, and therefore do not delete. Turkish does not have a Stronger-Weaker contact relationship between morphemes; only this would predict deletion of velars in these contexts.

2.7 Other root-final segments

Turkish nouns can end in a consonant other than velar stop /k/ or non-velar stop /p, t, tʃ/. Fricatives, nasal stops, and liquids are also possible. For roots ending in these consonants, no surface alternation is apparent: [efes-e] ‘Ephesus-DAT’, [kilim-e] ‘kilim rug-DAT’, [göl-e] ‘lake-DAT’. Under Resizing Theory, there are two possibilities for

explaining this apparent lack of alternation. The first possibility is that roots containing these consonants have size scales with just a single member. Thus, no contact relationship can possibly alter their phonological forms, because any “movement” on the scale -- whether one-point or end-point, whether upsizing or downsizing -- would have to begin and end at the only variant available.

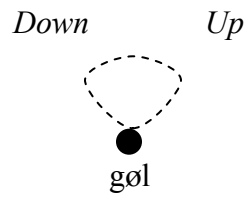

This possibility, while not especially interesting in theoretical terms, is plausible. Many languages have morpho-phonological alternations which apply to only a subset of possible segments, and exclude the rest. The division between the undergoers and the excluded is usually made on clear phonological grounds: in Turkish, for example, we see a division in the language between oral stops on the one hand, and all other consonants on the other. Since, in the current theory, the construction of size scales already operates on clear phonological grounds, it can certainly handle the segmental “exceptions” by an appeal to one-point scales.

The second possibility is that the apparent lack of alternation is just that: apparent. The supposedly excluded segments may actually undergo downsizing (upsizing) in a way that is sub-phonemic. For example, Turkish fricatives, nasal stops, and liquids may downsize by decreasing their durations in a way that is consistent, but not necessarily perceptible. These variants can take a rightful place on a scale, just as any other variant would, provided that their length can be straightforwardly defined relative to the other

variants. Under this scenario, then, the scale for a noun like [gøɫ] ‘lake’ would actually contain two points.

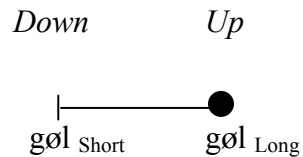

The shortest element on the scale, [gøɫ]_{Short}, contains a liquid [l] that is consistently shorter in duration than the [l] in the longest element on the scale, [gøɫ]_{Long}. Movement along this type of scale takes place in the same way as it does for any other scale.

Such a scenario obviously requires empirical confirmation. We would want to know, for example, if there is a class of nouns in Turkish whose final /l/ regularly undergoes shortening in suffixation (in which case we would say that they pattern with the Stronger roots) compared to another class of nouns whose final /l/ does not (plain roots). This would require measuring the duration of speech segments collected in a controlled experimental environment, a project that I leave for future work. In the meanwhile, it is worth noting that the hypothesis of sub-phonemic changes in Turkish segments other than /p, t, tʃ/ and /k/ has certain precedents in the literature (e.g., Turk 1994) and its investigation would represent a contribution to the proper characterization of the phonetics-phonology interface.

2.7 Limitations of Resizing Theory analysis

A conceptual limitation of the Resizing Theory analysis is that it does not capture the phonological tendencies that lurk within the Weaker-Stronger relationship.

Specifically, almost all of the suffixes in the Stronger class are vowel-initial (e.g., third possessive *-I*, accusative *-I*, dative *-E*) while almost all of the plain suffixes are consonant-initial (e.g., plural *-lEr*). I used the fact that this is only a tendency, and by no means absolute requirement, as justification for reformulating the alternations in morphological terms, but one might object that my analysis is still missing something.

An empirical limitation of the Resizing Theory analysis concerns roots of the shape CVCK, such as [renk] ‘color’. When such roots combine with a suffix from the Stronger class, Resizing Theory predicts velar deletion, but what actually occurs is voicing: [reng-i] ‘color-ACC’. Voicing is correctly predicted by a syllable-based theory in which this velar is not intervocalic, and therefore is not subject to deletion even though it occupies an onset. An in-depth examination of the full set of roots that pattern with [renk] would be required to bring them within the fold of Resizing Theory.

3. Upsizing in Northern Sotho

Turkish offered an example of two alternations united under the rubric of downsizing. Ohala (1997) and Blevins (2005) have offered a diachronic explanation of such patterns, claiming that the cross-linguistic tendency to delete voiced velars has its source in an aerodynamic voicing constraint. But Northern Sotho, briefly introduced at the beginning of this chapter, offers a mirror-image pattern in which devoicing and epenthesis can be united under the rubric of upsizing. Recall the basic pattern, evident in Class 9/10 nouns.

Northern Sotho:	/-bal/	→ [palô]	‘number’
	/-ilêl-/	→ [kilêlô]	‘a taboo’

This pattern cannot conceivably have the same diachronic explanation as the Pări one, highlighting the need for synchronic theory to meet the challenge of unifying a feature-based alternation with segment-based one, as Resizing Theory attempts to do. In this section, I give an overview of the Northern Sotho data and show how morpheme contact relationships and relative size scales can account for it. I also briefly review previous analyses of similar phenomena in related languages, and show how the current analysis differs.

3.1 Overview of the Northern Sotho pattern

In the brief example above, we have seen that in order to mark the Class 9/10 category in Northern Sotho, voiced consonants become voiceless. Furthermore, they may also alternate from fricative or approximant manner to stop manner. Additional data demonstrating the alternations is shown below.

Class 9/10 nouns, Poulos & Louwrens (1994: 456-457 except as noted)

Alternation	Example	Cf.
b [β] → p [p']	palô 'number'	-bal- 'count'
d [ɹ] → t [t']	tirô 'predicative'	-dir- 'do'
	tiêgô 'delay'	-diêg- 'lag behind, delay' (33)
r [r] → th [t ^h]	thêtô 'poem'	-rêt- 'praise'
	thapêlô 'prayer'	-rapêl- 'pray'
l → t [t']	temô 'agriculture'	-lem- 'plough'
	tôrô 'a dream'	-lôr- 'dream' (33)
bj [βz] → pš [pʃ']	pšalolô 'a transplant'	-bjalol- 'transplant'

Fricative consonants which are already voiceless undergo a full or partial alternation to stop: *phêtolô* 'an answer, reply' (cf. *-fêtol-*), *khumišô* 'enrichment' (cf. *-humiš-* 'enrich'),

tshêbi ‘backbiter’ (cf. *-sêb-* ‘speak evil of someone’), *tšhomišô* ‘utilisation’ (cf. *-šomiš-* ‘use’), *kgopolô* ‘a thought’ (cf. *-gopol-* ‘think’, where *g* = [x] and *kg* = [kx^h]), *mpshikêla* ‘flu’ (cf. *mfsikela* ‘kinds of flu’). The same initial-consonant changes also mark certain class 10 nouns which serve as an alternative plural of nouns from class 5, and in the adjectival concords of classes 8, 9, and 10 (Poulos & Louwrens 1994: 458-459).

These consonant changes also occur with prefixation of the first person object marker *N-* and with prefixation of the reflexive marker *i-*.

First person object, Poulos & Louwrens (1994: 177)

Alternation	Example	Gloss	Cf.
b [β] → p [p’]	Tatê o a mpitša	‘My father is calling me.’	-bitš- ‘call’
r [r] → th [t ^h] l → t [t’]	Tatê o nthomilê Modirô o a ntapiša	‘Father has sent me.’ ‘The work makes me tired’	-rom- ‘send’ -lapiš- ‘cause to become tired’
bj [βz] → pš [pʃ’]	Ba tla mpšalolêla pelo	‘They will transplant a heart for me.’	-bjalol- ‘transplant’

Reflexive, Poulos & Louwrens (1994: 186-188)

Alternation	Example	Gloss	Cf.
b [β] → p [p’]	O a ipalêla	‘She reads for herself.’	-balêl- ‘read for’
d [ɾ] → t [t’]	O a itirêla	‘He works for himself.’	-dirêl- ‘work for’
r [r] → t ^h l → t [t’]	re a ithuta le a itapiša	‘we are teaching ourselves’ ‘you are tiring yourselves’	-rut- ‘teach’ -lapiš- ‘tire’
j [ʒ] → tš	O a itšeša	‘he feeds himself’	-ješ- ‘feed’
bj [βz] → pš [pʃ’]	O ipšalêla mabêlê	‘She plants sorghum for herself.’	-bjalêl- ‘plant for’

Roots that are nasal-initial do not undergo any alternations; cf. *Ngaka e mmonokiša*

sehlare ‘The doctor lets me suck medicine’, from *-monokiš-* ‘cause to suck’ (Poulos &

Louwrens 1994: 178). Roots that already begin with a voiceless stop do not undergo alternations, either.

3.2 Basic analysis of Northern Sotho

Devoicing in Northern Sotho clearly serves a morphological purpose. It occurs only in the paradigms of the Class 9/10 prefix \emptyset -, first person object prefix *N*-, and the reflexive *i*-. These three prefixes each consist of their own segmental material, but this is independent of the morpheme contact relationship that they maintain with roots, which is the same for all three.

Roots ▷ Class 9/10, 1Obj, Reflexive

“The boundary between roots and the Class 9/10, first person object, and reflexive prefixes requires a relative strengthening on its left side and/or a relative weakening on its right. Edges only.”

(Note that Poulos & Louwrens 1994 analyze the Class 9/10 prefix as underlying *N*-, presumably in order to unify it with the first person object prefix *N*-. This is historically accurate but unnecessary in a synchronic analysis which attributes the behavior of this prefix not to its segmental content, but to its contact relationship with roots).

To manifest the relationship, the strong morpheme upsizes. The relative size scales for the roots *-bal-* ‘count’ and *-bjalol-* ‘transplant’ demonstrate the movement that occurs on the scale; in the absence of further evidence, we will consider this as a one-point movement.

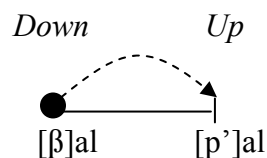

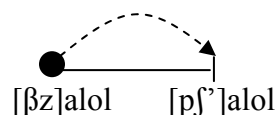

These scales above are isomorphic to one another; each scale has two points, and the two points on each scale are differentiated by the same length difference, namely voiced versus voiceless. Of course, the scales are also differentiated by other features, such as the fricative manner and pulmonic airstream mechanism for [β] versus the stop manner and glottalic airstream mechanism for [pʰ]. By hypothesis, these features do not contribute to the length of the morpheme, and thus play no direct role in the algorithm which constructs the scale. They may, however, play an indirect role because of the cross-linguistic preference for length to be associated with stop articulations, rather than fricative or a approximant articulations (Elmedlaoui 1993, Kirchner 2000, Podesva 2002), as discussed in Chapter 1.

An appeal to this preference could conceivably explain the other scales that are operative for Northern Sotho, by which liquids /ɹ, r, l/ upsize by devoicing, and concomitantly alternate to a stop articulation.

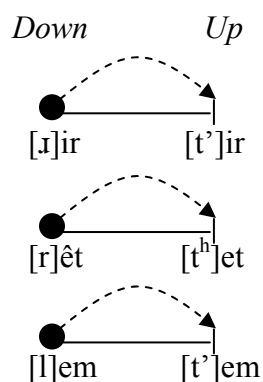

Again, on the basis of length alone, these scales are isomorphic both to one another and to the previous scales. That is, the two points on each scale are differentiated by the length difference of voiced versus voiceless; the concomitant alternation from liquid to stop may be due to the orthogonal constraint on long consonants to have maximum stricture. It is conceivable that such a constraint may lead to a situation in which a manner alternation from fricative or approximant to stop effectively substitutes for lengthening in those cases where no other upsizing relationship occurs, as in the Class 9/10 examples *phétolô* ‘an answer, reply’ (cf. *-fétol-*), etc.

3.3 Northern Sotho velar epenthesis

The interesting point about the Northern Sotho pattern concerns the behavior of vowel-initial roots. Resizing Theory predicts that strong roots which begin with a vowel should also exhibit upsizing when they combine with the Class 9/10, first person object, or reflexive prefixes. This prediction is borne out, but not by devoicing. Instead, nouns beginning in a vowel exhibit *epenthesis*, of voiceless velar [k]. Data from all three paradigms are shown below.

Class 9/10 prefix Ø- (Poulos & Louwrens 1994: 456-457)

Alternation

Ø → k’

Examples

kamogêlô ‘reception’
 kêpi ‘crowbar’
 kilêlô ‘a taboo’
 kišô ‘act of taking to’
 kôpêlô ‘song’
 kutollô ‘revelation’
 kutsô ‘theft’

Cf.

-amogêl- ‘receive’
 -êp- ‘dig’
 -ilêl- ‘avoid’
 -iš- ‘take to’ (34)
 -ôpêl- ‘sing’
 -utoll- ‘reveal’
 -utsw- ‘steal’ (35)

First person object *N-* (Poulos & Louwrens 1994: 178)

Alternation	Example	Gloss	Cf.
∅ → k'	O na nkapeêla	'She cooks for me.'	-ape- 'cook'

Reflexive *i-* (Poulos & Louwrens 1994: 188)

Alternation	Example	Gloss	Cf.
∅ → k'	o tla ikapeêla	'he will cook for himself'	-ape- 'cook'
	ba a ikuta	'they are hiding themselves'	-ut- 'hide'

In Resizing Theory, vowel-initial roots are subject to the same contact relationship as other roots, e.g. Roots▷Class 9/10. To manifest this relationship, there is a one-point upsizing movement on the size scale.

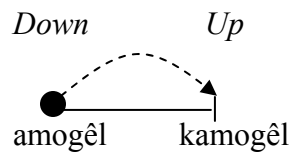

This scale contains two points, but is not isomorphic to those for consonant-initial roots because the distance between the points is characterized not by voicing versus voicelessness, but by absence versus presence of the segment [k]. The construction of the different scales for root size is determined solely by phonological factors -- i.e., the presence of an initial vowel versus an initial consonant -- and the morpheme contact relationship operates in exactly the same way in either case, triggering upsizing of the stronger morpheme according to whatever points exist on the scale in question. Northern Sotho therefore offers support for our prediction that devoicing and epenthesis should pattern alike. It also offers support for the prediction that, across languages, synchronic processes can operate in both directions -- given the Pãri, Turkish, and Finnish patterns,

we expect the mirror-image pattern to be attested as well, and Northern Sotho shows that it is.

3.4 Previous analyses of the Sotho languages

The Northern Sotho pattern is also attested in other languages of the Sotho group, such as Tswana, and its synchronic status is almost certainly the result of certain historical rule inversions in the sense of Vennemann (1972). The historical changes that gave rise to this pattern are discussed in Doke (1954), Dickens (1977, 1984), and Creissels (1999). A synchronic analysis is offered by Schaefer (1982). I address each in turn.

3.4.1 Historical analyses

Several historical analyses of the Sotho group have been published. In the summary that follows I draw primarily from Dickens (1984), whose examples are from the closely related language Tswana. The first singular object, the reflexive, and the class 9/10 noun prefixes share in common the fact that they historically contained syllabic nasal consonants. The first singular was **ni* in proto-Bantu, eventually becoming *N*. The reflexive was **yini*, becoming **iN* and later simply *i*. The Class 9 prefix was **ni*, eventually becoming *N* (Dickens 1977: 163). The nasal consonant plays an important role in three sound changes that occurred, in the following chronological order (Dickens 1984: 97).

1. Stopping, whereby voiced continuants became non-continuants after a nasal.

m-βona → mbona 'see me' (lit. me-see)

2. Friciation, whereby voiceless aspirated stops became fricatives in word-initial and intervocalic position, e.g. p^h → φ/ {#, V} __ V. This process subsequently became inverted, reinterpreted as a rule of voiceless “de-frication” after a nasal, e.g. φ → p / N ____.

m-φa → mp^ha 'give me'

3. Devoicing, whereby voiced non-continuants (the outputs of Stopping) become voiceless and sometimes ejected after a nasal.

m-bona → mpona 'see me'

These changes were followed by the deletion of nasals before consonants, except when stressed or in the first person object prefix (Dickens 1984: 123). The result is the synchronic pattern, in which stopping and devoicing are characteristic morphological markers of the first singular object (the only prefix which retains its nasal content), the reflexive, and class 9/10 prefixes.

The pattern of velar insertion has a different origin, arising from inversion of a historic deletion rule. At some point in the history of the Sotho group, intervocalic and word-initial *y underwent deletion: compare *m-adi* 'blood' in Tswana with *ma-gadzi* in Sukuma, compare also Tswana *aba* 'divide' with Nyoro *gaβa* (Dickens 1984: 115). Velar

deletion interacted with the rules of stopping and devoicing in the following ways (1984: 116):

	N-verb	N-noun	Verb alone
Proto-Bantu	N-ɣaraba	N-ɣarabo	ɣaraba
Stopping	ŋgaraba	ŋgarabo	--
ɣ-Deletion	--	--	araba
Devoicing	ŋkaraba	ŋkarabo	--
Nasal deletion	--	karabo	--
Tswana	ŋkaraba 'answer me'	karabo 'answer (n)'	araba 'answer (v)'

The result is the synchronic pattern, in which velar insertion parallels stopping and devoicing as a characteristic morphological marker for vowel-initial roots.

The diachronic analysis of Sotho languages is obviously enlightening, particularly in regard to the inverted origin of velar epenthesis. Still, its close similarity with the mirror-image patterns from Pări et al. suggests the need for a synchronic analysis as well.

3.4.2 Previous synchronic analysis

Most previous discussions of the Sotho pattern have been diachronic, but Schaefer (1982) offers a synchronic analysis. Focusing on Tswana, he places consonants into the following hierarchy (1982: 172).

	(w)		b	f			p, p ^h	
		l, r		s		tl, tl ^h	t, t ^h	ts, ts ^h
	(y)			š				dž, tš, tš ^h
	h			x			k, k ^h	kx ^h
vowel	glide	liquid	voiced stop	voiceless fricative	nasal	lateralized stop	voiceless stop	affricate
1	2	3	4	5	6	7	8	9

The basic idea is that “strong” environments, namely those after synchronic nasals and the reflexive prefix, trigger movement up the hierarchy. (A nasal for the Class 9/10 prefix is assumed to be underlyingly present, but undergoes subsequent deletion). The hierarchy is three-dimensional; its primary dimension is left-to-right along the horizontal axis, its secondary dimension is the vertical axis of different place features, and its tertiary dimension is the left-to-right ordering within a category (thus, t^h is stronger than ṭ). The fact that certain sounds, namely those at points 6 and above, do not strengthen at all is explained by the fact that they lie below a threshold.

Dickens (1984) offers a sharp critique of this proposal. It is not unreasonable, he writes, for a theory of strengthening to predict similar phenomena in other languages, but Schaefer’s analysis cannot do so even in related dialects, unless the elements on the hierarchy are re-arranged. But such rearrangement “would mean the end of ‘strengthening’ as a theoretically interesting concept, for it would mean nothing more than separate listings of the changes found in the respective dialects” (1984: 110). “Strengthening”, then, is a term that misleads us into thinking that these alternations can be meaningfully unified, when the only cogent explanation of them is in fact diachronic.

My own critique of arbitrary strengthening scales, presented in Chapter 1, is quite similar in spirit to Dickens’s critique of Schaefer’s hierarchy for Tswana, although I argue that a synchronic explanation is also viable. The solution that I have proposed, namely Resizing Theory, is partial insofar as it does not encompass the changes in consonant manner that we see in Northern Sotho and Tswana. Insofar as it encompasses changes in consonant length, however, Resizing Theory takes a positive step forward. Because length scales make crucial reference to an independent principle, namely relative

length, they make predictions that hold beyond the examples at hand; the picture that emerges is one in which consonant devoicing and epenthesis are predicted to pattern together not just in Northern Sotho, but in other languages as well.

3.5 Importance of Northern Sotho for evaluating articulation-based theories

The downsizing patterns in Pări, Turkish and Finnish form part of a larger trend in phonological typology whereby velar stops delete in the environments where other oral stops undergo voicing. Ohala (1997) explained the trend by invoking the aerodynamic voicing constraint (see also Blevins 2005). To produce voicing, speakers must maintain a pressure differential across the glottis. In articulations with a complete closure at the back of the vocal tract, such as velar stops, the cavity formed above the glottis is so small that the differential disappears rapidly and voicing can be maintained for only a short time, leading to potential deletion of the segment.

Despite its appeal, this proposal cannot account for the mirror-image pattern, which is also attested, as we have seen. In Northern Sotho first person objects, reflexives, and Class 9/10 nouns, the surface consonants in question are all voiceless, so the aerodynamic voicing constraint cannot be operative. Yet the pattern exhibits the same essential characteristics as in Pări et al. -- namely, the morphological equivalence of voicing features with the presence or absence full segments -- suggesting that they have a similar synchronic basis.

4. Upsizing in Hungarian

Northern Sotho roots exhibit either devoicing of their initial consonants, or epenthesis of [k]. To which morpheme does the segment [k] rightly belong? I have argued that it belongs to the root, such that a root like ‘receive’ has two variants: *amogél* ~ *kamogél*. This analysis allows us to unify the appearance of [k] with another upsizing alternation. More broadly, though, this line of thinking offers an opportunity to re-analyze any case in which the appearance of a particular segment (or segments) trades off with upsizing.

Consider the following data from Hungarian, which shows the instrumental and translative case suffixes in combination with vowel-final and consonant-final roots.

Root	Gloss	Instrumental	Translative	
nø	‘woman’	nøvel	nøve:	Kenesei, Vago, and Fenyvesi 1998: 437
fa	‘tree’	fa:val	fa:va:	Vago 1980: 100
vɔʃ	‘iron’	vɔʃʃɔl	vɔʃfa:	Kenesei, Vago, and Fenyvesi 1998: 396
kert	‘garden’	kerttel	kertte:	Kenesei, Vago, and Fenyvesi 1998: 437

After a vowel-final root such as [nø] ‘woman’, a [v] surfaces along with the instrumental and translative morphemes. After a consonant-final root such as [vɔʃ] ‘iron’, a geminate surfaces instead. Previous analyses have claimed that the underlying forms of the instrumental and translative morphemes contain a [v] which is subject to total assimilation when adjacent to a consonant (Vago 1980: 96-7; Kenesei, Vago, and Fenyvesi 1998: 436-7, Siptár & Törkenczy 2000: 267-274). In this section, I will argue that the [v] is actually epenthetic, and that Hungarian therefore provides additional

evidence for one of our primary predictions, namely that epenthesis and gemination should pattern together.

4.1 Overview of the Hungarian pattern

Let us begin by examining further examples of consonant gemination triggered by the instrumental and translative morphemes.

Hungarian instrumental and translative cases (Kenesei, Vago, and Fenyvesi 1998: 437)

Root	Gloss	Instrumental	Translative	
kalap	‘hat’	kalappal	kalappá	
rab	‘prisoner’	rabbal	rabbá	
kert	‘garden’	kerttel	kertté	
család	‘family’	családdal	családdá	
ponty	‘carp’	pontytyal	pontytyal	[cc]
ágy	‘bed’	ágygyal	ágygyá	[tʰ]
szűk	‘tight’	szűkkel	szűkké	
ég	‘sky’	éggel	éggé	
öv	‘belt’	övvel	övvé	
orosz	‘Russian’	oroszszal	oroszszá	[ss]
gríz	‘grits’	grízzel	grízzé	
piros	‘red’	pirossal	pirossá	[ʃʃ]
darázs	‘wasp’	darázsstal	darásztá	[ʒʒ]
sah	‘shah’	sahhal	sahhá	
ketrec	‘cage’	ketreccel	ketretccé	[tsts]
narancs	‘orange’	narancscsal	narancscsá	[tʃtʃ]
öröm	‘joy’	örömmel	örömmé	
szén	‘coal’	szénnel	szénné	
arany	‘gold’	aranytal	aranytá	[ɲɲ]
fél	‘half’	féllel	féllé	
por	‘dust’	porral	porrá	
baj	‘trouble’	bajjal	bajjá	

The gemination that we see in the examples above is morphologically-conditioned because other case suffixes do not trigger it; cf. [vɔʃ-ɔn] ‘iron-SUPERESSIVE’.

4.2 Basic analysis of Hungarian

In the analysis that I propose, assimilation does not play a role, and /v/ is not considered to be underlyingly present on the instrumental or translative morphemes. Rather, [v] is an epenthetic segment. It gets inserted in just those cases where the root ends in a vowel. When the root ends in a consonant, gemination occurs instead. In other words, epenthesis and gemination pattern together for the same morphological effect, as Resizing Theory predicts.

Analyzed in the framework of the current study, then, there is a contact relationship which states that noun roots are stronger than the instrumental and translative morphemes.

Roots ▷ Instrumental, Translative

“The boundary between roots and the instrumental or translative requires a relative strengthening on its left side and/or a relative weakening on its right. Edges only.”

This relationship is manifested by the upsizing of the strong morpheme, as shown in the following scale, whose points are differentiated by a singleton-geminate contrast.

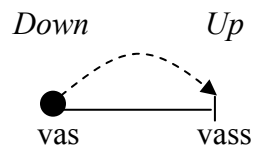

The size scale for vowel-final roots is different, however. It is not isomorphic to that for consonants, because it contains two points that are differentiated by the absence or presence of the segment [v].

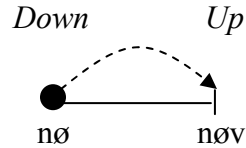

The idea is that [v] epenthesis is an upsizing alternation that takes place in a precise phonological environment: namely, after vowels. Therefore, [v] does not properly belong to the instrumental and translative suffixes, but rather forms part of a general strategy for making roots longer.

4.3 Supporting evidence for epenthesis

Supporting evidence for this conception of [v] epenthesis comes from independent processes in Hungarian. In the verbal paradigm, five roots exhibit a pattern that is unique within the language. When these roots, which include ‘shoot’, ‘grow’, ‘cook (intransitive)’, ‘weave’, and ‘scribble’, combine with a consonant-initial suffix, the vowel of the root is always long. The following examples are from the paradigm for ‘shoot’ (examples from Vago 1980: 76).

lø:-sz	‘shoot-2SG.INDEF’
lø:-tøk	‘shoot-2PL.INDEF’
lø:-nek	‘shoot-3PL.INDEF’
lø:-tt-em	‘shoot-PAST-1SG.INDEF’
lø:-ne:-k	‘shoot-COND-1SG.INDEF’
lø:-j-ek	‘shoot-SUBJ-1SG.INDEF’

When these roots combine with a vowel-initial suffix, however, the vowel is short and the segment [v] appears (examples from Vago 1980: 76).

løv-øk	‘shoot-1SG.INDEF’
løv-yнк	‘shoot-1PL.INDEF’
løv-øm	‘shoot-1SG.DEF’
løv-ød	‘shoot-2SG.DEF’

There is thus a trade-off between vowel length on the one hand, and epenthesis of [v] on the other. The trade-off is clearly a phonological one because the conditioning environment is defined in terms of the initial segment of the following suffix, which is either a consonant or a vowel. We do not expect phonological conditioning of this kind to affect morphological realization, and so we may consider [lø:] and [løv] to be morphologically equivalent. The same claim is implicit in the size scales for [vɔf] ~ [vɔff] ‘iron’ and [nø] ~ [nøv] ‘woman’ above. The conditioning environment (or in other words, the factor which determines which size scale we are operating on) is defined in terms of the final segment of the root, which is either a consonant (in which case we get gemination [vɔff]), or a vowel (in which case we get epenthesis, [nøv]).

Hungarian has a similar set of roots in the nominal paradigm, and these also support the idea that segment lengthening and [v] are morphological equivalents. The roots are [tʃø:] ‘pipe’, [kø:] ‘stone’, [lo:] ‘horse’, [tø:] ‘stem’, [fy:] ‘grass’, [n^yy:] ‘maggot’, [su:] ‘woodworm’, and [le:] ‘liquid’. As before, when these roots combine with a consonant-initial suffix, that vowel is always long (examples from Vago 1980: 113).

lo:-na:l	‘horse-ADESSIVE’
lo:-ke:nt	‘horse-ESSIVE.FORMAL’

When the roots combine with a vowel-initial suffix, however, the vowel is short and [v] appears.

lov-ak	‘horse-PLURAL’
lov-at	‘horse-ACCUSATIVE’
lov-astul	‘horse-ASSOCIATIVE’

A surface exception to this generalization occurs in the causal-final, [lo:-e:rt]. According to Vago (1980: 100), however, the causal-final suffix is underlyingly consonant-initial, /we:rt/, and so this exception actually fits into the generalization.

Another surface exception to this generalization occurs in the instrumental [lo:v-al]. Here the vowel is long even though [v] is also present. Yet we have already established that the instrumental participates in a strength relationship with noun roots (Roots▷Instrumental, Translative). In just this instance, then, we actually predict a gang-up effect, where multiple sources of length can remain on the root in order to realize the relationship via upsizing. Therefore, we see both a long vowel and [v] at the same time.

It is interesting to consider whether the vowel-lengthening and [v]-epenthesis exhibited in ‘shoot’-verbs and ‘horse’-nouns arises from a morpheme contact relationship or not. If it does, we would expect that neither of these processes should be in evidence when the roots occur in isolation (that is, when no contact relationship is operative). In fact, however, ‘shoot’ has a long vowel in isolation, [lø:], as do the other verbs in its class: [nø:] ‘grow’, [fø:] ‘cook (intransitive)’, [sø:] ‘weave’, and [ro:] ‘scribble’. In just these cases, however, vowel lengthening could be the result of a general constraint which prohibits short vowels [ø, o] in stem-final position; this is “one of the few phonotactic constraints that has an active role in the phonology of Hungarian” (Siptár & Törkenczy 2000: 144). It is therefore possible, albeit not provable, that ‘shoot’-verb roots in

Hungarian consist of a short vowel underlyingly. If so, we could say that the root gets lengthened under suffixation because of morpheme contact relationships, while it gets lengthened in isolation because of phonotactic constraints. This argument would be somewhat more difficult to maintain for the ‘horse’-nouns, some of which end in vowels other than [ø, o]. Regardless, in both verbal and nominal paradigms there is a clear phonological trade-off between lengthening and [v], and this is all that matters for our present concern.

There is one last piece of evidence in support of our claim that [v] is epenthetic in Hungarian. Besides the instrumental and translative, there are other morphemes in the language that begin with a [v] on the surface, such as the derivational *-van ~ -ven* of numerals, and the derivational *-va ~ -ve* and *-ván ~ -vén*, which derive adverbs from verbs. Unlike the instrumental and the translative, however, these morphemes do not trigger gemination when they attach to consonant-final roots (examples from Vago 1980: 97).

[øt]	‘five’	[øtven]	‘fifty’
[n ^y olts]	‘eight’	[n ^y oltsvøn]	‘eighty’
[kilents]	‘nine’	[kilentsven]	‘ninety’
[mond]	‘say’	[mondva]	[mondva:n]
[yl]	‘sit’	[ylve]	[ylve:n]
[la:t]	‘see’	[la:tvø]	[la:tva:n]

In the theory of morpheme contact relationships, these data make sense because there is no mechanism of total assimilation at play, only upsizing or downsizing alternations. The [v] shows up in certain contexts as an epenthetic segment, and these contexts are, by definition, in complementary distribution with consonant gemination. In previous

analyses (see works cited above), by contrast, the presence of the [v] is precisely what triggers total assimilation in the first place, and so we are forced to say that this process only targets certain [v]s and not others.

Hungarian therefore provides good support for the predictions of morphological contact relationships, because the data demonstrate how an epenthetic segment trades off with other lengthening processes, not just in one environment, but in several. Of course, most cases of what we call “epenthesis” do not have morphological motivations at all, but occur in order to repair phonological problems such as vowel hiatus or illicit consonant clusters. These cases lie outside the scope of the theory of morpheme contact relationships. When epenthesis can be shown to have a morphological role, however, we predict it to pattern with other upsizing alternations.

5. Upsizing in LuGanda and Choctaw

With epenthesis conceptualized as an upsizing alternation, we can also offer a felicitous analysis of certain patterns in Luganda and Choctaw. These patterns are of interest because multiple segments, not just one, are epenthesized. In this section, then, I briefly discuss multiple-segment epenthesis in LuGanda and Choctaw, and then compare it to the cases of single-segment epenthesis we have already examined.

In LuGanda, consonant gemination is a marker of the Class 5 nominals (Clements 1986: 62-63).

Class 5	Class 6	Stem (UR)	
kkubo	makubo	-kubo	‘path’
ttabi	matabi	-tabi	‘branch’
ddaala	madaala	-daala	‘step’

Consonant gemination is not the only means by which Class 5 nominalization can be realized, however. Roots that begin in a vowel or a pre-nasalized consonant take the segmental prefix *li-* instead: /-ato/ → *lyaato* ‘boat’, /-mpi/ → *liimpi* ‘short’. (The surface long vowels result from independently motivated processes of glide formation and pre-nasalization, cf. Clements 1986). Roots that begin with an underlying geminate also pattern this way: /-ɲɲo/ → *liɲɲo* ‘tooth’.

In his analysis of LuGanda, Clements (1986) offers evidence to support the idea that the initial nasal in a root such as /-mpi/ is actually vocalic. That is, while the nasal contains the features for [m], it is associated to a V unit on the timing tier. He also offers evidence that the first half of a geminate is vocalic. Again, while the geminate contains the features for a consonant, it attaches to one V unit and one C unit on the timing tier.

If Clements’s analysis is correct, we can state the following distribution: gemination occurs before consonants and [li] occurs before vowels. (And regardless, the conditioning environments for gemination versus [li] are still definable in phonological terms). Both alternations are the result of a morpheme contact relationship.

Roots ▷ Class 5

“The boundary between roots and the Class 5 morpheme requires a relative strengthening on its left side and/or a relative weakening on its right. Edges only.”

This relationship gets realized by upsizing of the strong morpheme. The shape of the relative size scales diverges according to the status of the initial segment in the root: consonant-initial roots show a singleton-geminate difference while vowel-initial roots show a difference between the presence versus absence of [li]. But the contact relationship triggers the same upsizing movement in either case.

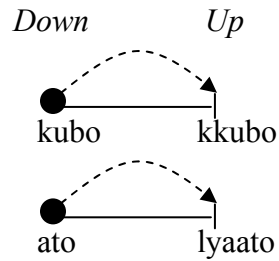

Choctaw (Haag & Willis 2001) also shows evidence of a trade-off between gemination and the appearance of multiple segments. In Choctaw, resolutional aspect in verbs is marked by gemination of the consonant that begins the penultimate syllable, stress on the antepenultimate syllable, and lengthening of the vowel following the stressed syllable. Verbs with at least three syllables and no consonant clusters follow this basic algorithm (glosses and vowel lengthening are not indicated in the examples from the source, Haag & Willis 2001: 166ff):

hoponi → hópponi

However, verbs with only two syllables epenthesize a new syllable. The new syllable contains the geminate [jj] (orthographic *yy*) and a copy of the root vowel.

foha → fójjoha (orthographic *foyyoha*)
hokli → hójjokli

Verbs with consonant clusters also epenthesize the geminate [jj] and a copy vowel.

haksichi → hakséjjechi (orthographic *haksiechi*)

The resolutional aspect morpheme in Choctaw would appear to be an infix. It enters into the following contact relationship with roots.

Roots > Resolutional aspect

“The boundary between roots and the resolutional aspect morpheme requires a relative strengthening on its left side and/or a relative weakening on its right.”

The relationship gets manifested by upsizing the strong morpheme. The shape of the scales diverges according to the prosodic shape of the root. The scale for some roots shows a singleton-geminate difference (along with, according to the description in Haag & Willis, a short-long vowel difference), while the scale for other roots shows a difference between the absence and presence of [jjV].

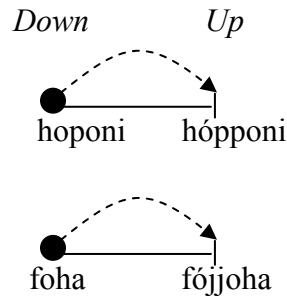

The trade-off between gemination and the appearance of multiple segments, exhibited by both LuGanda and Choctaw, is of interest precisely because it cannot be handled by traditional approaches. Recall that in Hungarian, the trade-off between gemination and the appearance of a single segment could conceivably be handled by an appeal to total assimilation. Although I argued against this approach, it does still capture the idea that the absence of [v] in certain contexts is evenly compensated for by the appearance of a geminate consonant. In terms of CV theory, the number of timing units remains consonant.

In LuGanda and Choctaw, however, the trade-off between gemination and the appearance of two or three segments cannot be given a really coherent explanation by

anything in the traditional toolbox. Clements (1986) formulates a rule for LuGanda whereby /li/ is the underlying form of a Class 5 prefix. When /li/ attaches to consonant-initial roots, the [l] deletes completely while the [i] is subject to total assimilation via auto-segmental spreading coming leftward from the root consonant. Thus while the disappearance of [i] is compensated for by the appearance of a geminate, the disappearance of [l] is not. The number of timing units does not remain constant, and so a timing-tier analysis seems ill-motivated. The Choctaw data present similar problems, except that here there is not one, but two extra timing units whose presence is not accounted for.

6. Compensatory Resizing

In this chapter, my claim has been that despite phonological constraints, movement on size scales always occurs in the same fashion, such that all upsizing (or downsizing) alternations pattern together. Occasionally, however, a phonological constraint may impede the upsizing of a strong morpheme (or downsizing of a weak morpheme), thereby threatening the realization of the relationship. In these cases, the current theory predicts *compensatory* downsizing of the weak morpheme (or conversely, upsizing of the strong). In other words, a reversal can occur to ensure that the strength relationship is realized. Evidence that could potentially support this prediction comes from both Meithei and Ibibio.

6.1 Meithei compensatory downsizing

In Meithei (Chelliah 1997), root-final consonants geminate whenever they attach to a vowel-initial suffix. The pattern is exemplified in the following data, which demonstrate suffixation of the non-hypothetical *-í*, the experiential *-e*, and the imperative *-u* (examples from Chelliah 1997: 66-67).

tʃél-	‘run’	tʃéllí	‘runs’
tʃəŋ-	‘enter’	tʃəŋŋí	‘enters’
ləy-	‘be’	ləyyí	‘is’
tʰəm-	‘keep’	tʰəmme	‘keeps’
tʰəm-	‘keep’	tʰəmmu	‘keep!’
yeŋ-	‘look’	yeŋŋu	‘look!’

This pattern is not confined to specific roots or suffixes, but rather appears to be a general relationship holding between all roots and suffixes in the language, provided that the requirement of an intervocalic environment for gemination is met. We can therefore analyze the pattern with the following relationship.

Roots ▷ Suffixes

“The boundary between roots and suffixes requires a relative strengthening on its left side and/or a relative weakening on its right.”

In the examples above, the relationship is manifested by the upsizing of the strong morpheme.

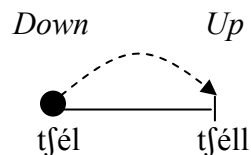

When the verb root ends in a vowel, however, phonological constraints prevent the relationship from being realized in this way. For vowel-final roots, upsizing of the strong

morpheme would entail either vowel lengthening or perhaps epenthesis. But Meithei does not have long vowels, and epenthetic glides and glottal stops are already used as phonological repairs for vowel hiatus, weakening any potential morphological role they could have. So, in just this case, Meithei exhibits a reversal: the suffix reduces from a full vowel to the second part of a diphthong (examples from Chelliah 1997: 23, 203).

/ú -í/ → [új]
 ‘see’ -NONHYP

/tʃá -í/ → [tʃaj]
 eat -NONHYP

/tʃá -u/ → [tʃaw]
 eat -IMP

In other words, in the vowel-final environment, the contact relationship between Meithei roots and suffixes is manifested by downsizing of the weaker morpheme. This is shown on the following size scales, where the diphthong components [j] and [w] have shorter lengths than the full vowels [i] and [u], respectively.

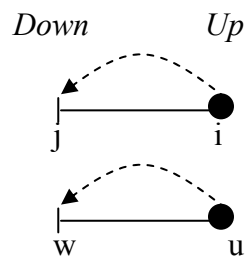

The Meithei pattern is therefore an example of compensatory downsizing.

6.2 Compensatory downsizing in Ibibio

Another potential example of a compensatory resizing comes from Ibibio, where many processes are constrained by a disyllabic foot structure (Urua 2000, Harris & Urua 2001, Akinlabi & Urua 2002). The foot can have a light-light shape (CV.CV), or one of two heavy-light shapes (CVV.CV) or (CVC_i.C_iV). Furthermore, position within the foot conditions certain segmental alternations.

We will be concerned here with the negative morpheme, which alternates between *-ké* in foot-initial positions and *-yV* in foot-medial positions, where V is a copy of the root vowel. When the negative attaches to a monosyllabic root of the shape CV, the vowel lengthens (examples from Akinlabi & Urua 2003: 126).

sé	‘look’	ń-séé-yé	‘I am not looking’
nò	‘give’	ń-nòò-yó	‘I am not giving’
dó	‘be [copula]’	ń-dóó-yó	‘I am not’
dá	‘stand’	ń-dáá-yá	‘I am not standing’

The vowel-lengthening pattern above suggests that verb roots and the negative morpheme are in a strength relationship with one another.

Roots > Negative

“The boundary between roots and the negative morpheme requires a relative strengthening on its left side and/or a relative weakening on its right.”

This relationship gets manifested by the upsizing of the strong morpheme, as in the following size scale.

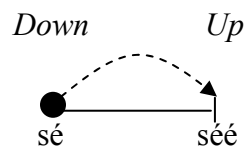

For other verb roots, however, the Ibibio maximal foot template of (CVX.CV) prevents the strength relationship from being realized by upsizing of the strong root. In just these cases, the relationship can be realized by downsizing of the weak suffix. For example, when the reversive suffix attaches to monosyllabic roots of the shape CVVC, this produces a foot (CVVC.kV). This foot is already bigger than the maximal size; therefore, the root has no licit way to upsize. So a reversal occurs: the weak morpheme downsizes by deleting its initial /k/, and all that remains of the negative is a vowel V (examples from Akinlabi & Urua 2003: 126).

kóóŋ	‘hang on hook’	...kóóŋó	‘...not hanging on hook’
ɲòòŋ	‘crawl’	...ɲòòŋó	‘...not crawling’
wèèm	‘flowing’	...wèèmé	‘...not flowing’
kóót	‘read/call’	...kóóró	‘...not reading/calling’
déép	‘scratch’	...dééβé	‘...not scratching’

We can depict this process in the following size scale, where the reversive variant that has undergone deletion (and is therefore reduced just to *V*) has a shorter length than its counterpart *-kV*.

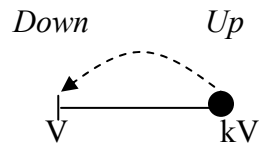

In Ibibio, then, the weight difference between CV and CVVC roots determines how the morpheme strength relationship gets realized. For monosyllabic verb roots of the shape CVC, however, the correct analysis is somewhat elusive. In these cases, the negative morpheme always produces a surface geminate, and no evidence of the features associated with /k/ remains (examples from Akinlabi & Urua 2003: 125).

dép	‘buy’	í-dép-pé	‘s/he is not buying’
kòp	‘hear’	í-kòp-pó	‘s/he is not hearing’
yét	‘wash’	í-yét-té	‘s/he is not washing’
bót	‘mould’	í-bót-tó	‘s/he is not moulding’
dát	‘take/pick up’	í-dát-tá	‘s/he is not taking’
ɲèk	‘shake’	í-ɲèk-ké	‘s/he is not shaking’
dóm	‘bite’	ń-dóm-mó	‘I am not biting’
nám	‘do/perform’	ń-nám-má	‘I am not performing’
bòn	‘father a child’	ń-bòn-nó	‘I am not fathering a child’
bén	‘carry [with hand]’	ń-bén-né	‘I am not carrying...’
sàŋ	‘go’	ń-sàŋ-ŋá	‘I am not going’
kòŋ	‘knock’	ń-kòŋ-ŋó	‘I am not knocking’
kòp	‘lock’	...kòp-pó	‘unlock’ (A & U 2003: 140)
wèt	‘write’	...wèt-té	‘not writing’ (A & U 2003: 140)

It is possible that both upsizing and downsizing are operative here. Under this scenario, the strong root upsizes by gemination. This creates a foot (CVCC.kV) that violates the maximal template. To repair this situation, downsizing of the weak suffix also occurs, via deletion of /k/, producing the licit foot (CVC_i.C_iV). However, an alternative analysis is that the root and suffix undergo simple concatenation, followed by total progressive assimilation: /CVC_i-kV/ → [CVC_iC_iV]. The facts of Ibibio are complex and I cannot resolve the ambiguity here; the reader is referred to Akinlabi & Urua (2003) for further examples and discussion. Still, it should be clear that with CVVC roots, at least, the negative morpheme exhibits compensatory downsizing.

7. A cline of contact relationships in T^hese

Resizing Theory predicts that contact relationships exist along cline of heights, which should be reflected by a cline of sizes in the surface variants of a particular element. The language T^hese bears this out. The prefixes of T^hese (Nilo-Saharan, Sudan; Yip 2004) have a number of different phonological effects on the root-initial consonants,

as can be seen in the paradigms below for the roots $t\dot{o}k^w\grave{e}$ ‘plant (v)’, $p\acute{o}s\grave{e}$ ‘anoint’ and $p\grave{e}$ ‘see’. (All data from Yip [2004: 109-114]. Data include all members of the verb paradigm provided by the source. Data also include tone changes, which are not analyzed in Yip 2004 and which we will not analyze here. Verb roots are identical to the 3SG.IMPF form).

	‘plant’		‘anoint’		‘see’	
3SG.IMPF	$t\dot{o}k^w\grave{e}$	‘he/she plants’	$p\acute{o}s\grave{e}$	‘he/she anoints’	$p\grave{e}$	‘he/she sees’
1SG.IMPF	$\grave{a}-t\dot{o}k^w\acute{e}$	‘I plant’	$\grave{a}-h\grave{o}s\grave{e}$	‘I anoint’	$\grave{a}-h\acute{e}$	‘I see’
1SG.PF	$\acute{a}-t\dot{o}k^w\grave{e}$	‘I planted’	$\acute{a}-pp\acute{o}s\acute{e}$	‘I anointed’	$\acute{a}-pp\acute{e}$	‘I saw’
2SG.IMPF	$\grave{e}-d\dot{o}k^w\grave{e}$	‘you (sg) plant’	$\grave{e}-b\acute{o}s\acute{e}$	‘you (sg) anoint’	$\grave{e}-b\acute{e}$	‘you (sg) see’

These data reflect a combination of morphologically-conditioned and general processes. The morphologically-conditioned processes are gemination, which is conditioned by the 1SG.PF morpheme, and voicing, which is conditioned by the 2SG.IMPF morpheme. The general process is intervocalic reduction, by which the root-initial consonant /t/ reduces to a retroflex flap [ɽ] and /p/ reduces to [h]. Reduction occurs when the 1SG.IMPF is prefixed to a root, but in most other intervocalic environments as well. Thus, in the ^hese lexicon, retroflex voiceless stops only occur in word-initial positions, cf. $t\acute{a}r\acute{e}$ ‘pot’ and $t\acute{u}ún\acute{e}$ ‘a short big trunk of wood’, while their retroflex flap counterparts only occur in intervocalic positions, cf. $b\grave{a}l\acute{u}k$ ‘stool, long bench’ and $k\grave{e}t\acute{a}r\acute{e}$ ‘pots’ (from underlying /k\grave{e}-t\acute{a}r\acute{e}/). The facts for voiceless labial stops are similar but somewhat more complex. In initial position, /p/ is in free variation with [f] as well as [h].

In intervocalic position, /p/ can reduce to either [b] or [h], cf. /pírípíritək/ ‘dragonfly’ which is pronounced by some speakers as [hírìbíridək] and by others as [hírìhírìdək]. In the verbal paradigms, however, intervocalic /p/ is always realized as [h].

A puzzle with T^hese arises when we consider the paradigms for other verb roots, such as those which are liquid-initial or nasal-initial.

	‘being’		‘make’			
3SG.IMPF	rè	‘being’ 3 rd person sg	lèmè	‘he makes’		
1SG.IMPF	à-ré	‘being’ 1 st person sg imperfect	à-lémé	‘I make’		
1SG.PF	árré	‘being’ 1 st person sg perfect	állémé	‘I made’		
2SG.IMPF	èrré	‘being’ 2 nd person sg imperfect	èllémé	‘you (sg) make’		
	‘drink’		‘press’		‘walk’	
3SG.IMPF	máttélê	‘he/she drinks’	ɲugumɔ	‘he/she presses’	ɲùrè	‘he/she walks’
1SG.IMPF	à-máttélé	‘I drink’	à-ɲugumɔ	‘I press’	à-ɲùré	‘I walk’
1SG.PF	ámmáttélé	‘I drank’	áɲɲugumɔ	‘I pressed’	áɲɲùré	‘I walked’
2SG.IMPF	m̀máttéláné	‘you (sg) drink’	ɲ̀ɲùgumɔ	‘you (sg) press’	ɲ̀ɲùré	‘you (sg) walk’

In these paradigms, gemination is conditioned by the 1SG.PF, just as we might expect.

However, gemination is also triggered by the 2SG.IMPF. This is unexpected because in the plosive-initial paradigms, we saw that *voicing* occurred in this morphological environment. Of course, liquids and nasals are already voiced, so it makes sense to think that a process of voicing could not really apply to them. But why would the voicing process be replaced by gemination? A further puzzle involves the disappearance of the

prefix ε - in nasal-initial roots. We would like a theory which can capture the seemingly disparate behavior of plosive-initial roots on the one hand, and liquid- and nasal-initial roots on the other.

7.1 Plosive-initial roots

We begin an analysis of T^hese by constructing a size scale for plosive-initial roots, using the root $t\partial k^w\varepsilon$ ‘plant (v)’ as an example. (Because my analysis makes no claims about tone alternations in roots, I have removed tones from the size scale in order to avoid confusion, but I have retained them elsewhere).

Size scale for T^hese ‘plant (v)’

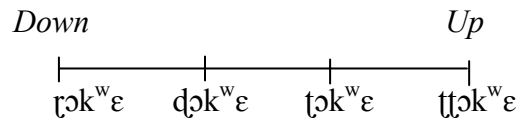

As before, the longest variant is at one end of the scale and the shortest variant is at the other. The locus of duration changes is the root-initial consonant, which can be a flap (shortest, or downsizing end), a voiced singleton, a voiceless singleton, or a voiceless geminate (longest, or upsizing end).

To complete our construction of the scale, let us revisit the definition of the starting point.

STARTING POINT for scalar movement: The variant which would occur when *no* strength relationship is operative.

In word-initial positions in T^hese, as exemplified in the 3SG.IMPF forms such as $[t\partial k^w\varepsilon]$ ‘he/she plants’, the starting point is the same as the underlying form. This is because no

other phonological processes, which could potentially change the underlying form, are applicable in this environment. The starting point is shown with a circle.

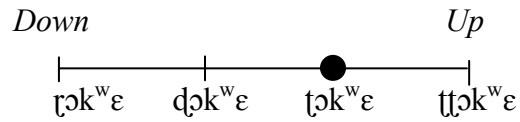

In intervocalic positions in T^hese, however, the starting point is not the same as the underlying form. This is a direct consequence of intervocalic consonant reduction. The vowel-final prefixes under consideration, á-, à-, è-, all create the intervocalic environment required for reduction. If no strength relationship is operative (that is, if no special morphological conditioning is present), reduction takes place. This produces the variant [ɾɔkʷɛ́], which is therefore the starting point for subsequent scalar movement for these environments.

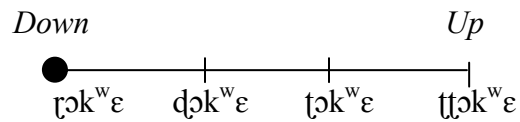

This definition for scalar starting points contradicts the Elsewhere Principle, which claims that more specific processes (such as those triggered by a particular morpheme) occur first in the course of a derivation, and more general, “elsewhere” processes occur last (e.g. Kiparsky 1973, Anderson 1986, 1992). Under the Elsewhere Principle, gemination would be triggered immediately by the addition of the first singular past morpheme, producing áttɔkʷɛ̀ ‘I planted’. Gemination would then bleed reduction. A similar scenario would occur with voicing, which would be triggered immediately by the

addition of the second singular present, producing $\text{ɛ}d\text{ɔ}k^w\text{ɛ}$ ‘you plant’, and also bleeding reduction. In the discussion that follows, however, we will see that our definition for scalar starting points provides a crucial link in a unified analysis of T^hese, suggesting that the Elsewhere Principle may not always be appropriate.

To proceed with the analysis of T^hese, we set up two contact relationships.

Roots ▷ 2sg. Impf

“The boundary between roots and the 2SG.IMPf morpheme requires a relative strengthening on its left side and/or a relative weakening on its right.”

Roots ▷ 1sg. Pf

“The boundary between roots and the 1SG.PF morpheme requires a lot of relative strengthening on its left side and/or a relative weakening on its right.”

As before, relationships between morphemes determine movement along the root size scale. In T^hese, relationships manifest themselves by the strong morpheme getting longer. In the case of the relationship involving the 2SG.IMPf morpheme, the strength differential is only enough to move the root one point on its size scale toward the longer end. For the 1SG.PF morpheme, the differential is great enough to move the root to the upsizing endpoint of the scale.

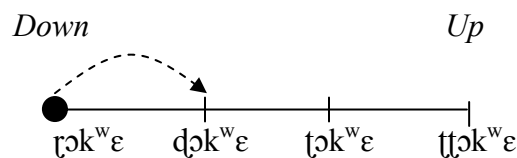

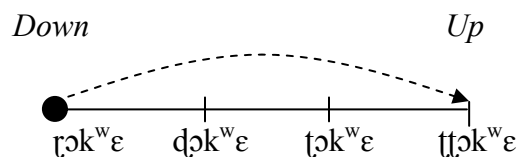

e.g. $/\text{ɛ}-\text{ɾ}\text{ɔ}k^w\text{ɛ}/$ (\rightarrow $[\text{ɛ}-\text{ɾ}\text{ɔ}k^w\text{ɛ}]$) \rightarrow $[\text{ɛ}d\text{ɔ}k^w\text{ɛ}]$ ‘you (sg) plant’



e.g. /á-tʃòkʷɛ̃/ → (→ [á-tʃòkʷɛ̃]) → [átʃòkʷɛ̃] ‘I planted’

The following table summarizes the analysis of T^hese presented thus far.

Summary of relationships for T^hese tʃòkʷɛ̃ ‘plant (v)’

<i>Prefix</i>	<i>Underlying form</i>	<i>Strength relationship</i>	<i>Root variant</i>	<i>Surface form</i>
3SG.IMPF	tʃòkʷɛ̃	None	tʃòkʷɛ̃	tʃòkʷɛ̃
1SG.IMPF	à-tʃòkʷɛ̃	None	tʃòkʷɛ̃	àtʃòkʷɛ̃
1SG.PF	á-tʃòkʷɛ̃	Roots  1sg. Pf	tʃòkʷɛ̃	átʃòkʷɛ̃
2SG.IMPF	ɛ̃-tʃòkʷɛ̃	Roots  2sg. Impf	ɔ̃kʷɛ̃	ɛ̃ɔ̃kʷɛ̃

7.2 Liquid-initial and nasal-initial roots

We are now ready to face the primary puzzle presented by the T^hese data. Recall that the puzzle centers around the 2SG.IMPF, which triggers voicing in plosive-initial roots but gemination in liquid-initial and nasal-initial roots. To see how strength relationships handle this pattern, let us construct an size scale for liquid-initial roots, using *lèmè* ‘make’ as an example. Only two variants are attested, one with a singleton consonant [lémè], and one with a geminate consonant [llémè]. This gives us the following two-point size scale.

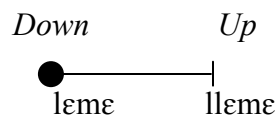

The starting point, *lémè*, is the variant which would occur when no strength relationship is operative. Unlike plosives, liquids and nasals do not undergo reduction in intervocalic

environments (cf. T^hese words such as *tàlá* ‘cough’, *tàrá* ‘guard’, *làmək* ‘food’, and *tónò* ‘belly’), so their starting point is identical in word-initial and intervocalic environments³.

The strength relationships that we have proposed for T^hese are as follows.

$$\begin{array}{l} \text{Roots} \triangleright 2\text{sg. Impf} \\ \text{Roots} \triangleleft 1\text{sg. Pf} \end{array}$$

As we saw, the first relationship pushes the root one point toward the strong end of the size scale, while the second pushes the root to the strongest endpoint. Crucially however, for the root *lèmè*, which has only two points on its scale, these two operations produce exactly the same effect.

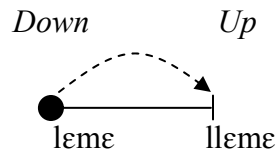

e.g. /ɛ-lèmɛ/ → [ɛllémé] ‘you (sg) make’
 /á-lèmɛ/ → [állémé] ‘I made’

That is, a one-point movement on the scale is neutralized with an endpoint movement.

This produces the correct result: the root variants for the 2SG.IMPf and the 1SG.PF are the same for this root, both exhibiting gemination, even though they were distinguished for the stop-initial root, where one exhibited gemination and the other exhibited voicing.

A similar analysis can handle the nasal-initial roots, which also exhibit gemination in the context of both the 2SG.IMPf and the 1SG.PF. Recall that the nasals

³ If it turns out to be appropriate to analyze tones in the framework of strength relationships, we would need to refine this statement. The tonal allomorphs are clearly different for the word-initial examples of the 3SG.IMPf (*lèmè* ‘he/she makes’) and the intervocalic examples of the 1SG.IMPf (*à-lémé* ‘I make’).

exhibit an additional twist, which is that the 2SG.IMPf prefix è- appears to delete (or at the very least, its segmental material deletes; the tone appear apparently remains), cf.

m̀m̀áttélané ‘you (sg) drink’. Under the current analysis, this could be a direct result of the strength relationship Roots > 2sg.Impf. This relationship happens to get manifested in multiple ways: by the root becoming longer, as we already saw, and by the prefix becoming shorter – that is, so short that its segmental content deletes entirely. Of course, this raises the question as to why no prefixal deletion occurs as the result of the relationship between roots and the 1SG.PF, where the strength differential is greater, but I do not have an answer to this question here.

7.3 Limitations

The analysis that I have offered of T^hese is partial. A vexing problem remains, which is the appearance of a nasal in certain 2SG.IMPf contexts.

a.	àl̀̀	‘he ties’	ɲ̀ǹáɫ ~ èǹáɫ	‘you (sg) tie’
	ìtì	‘he comes’	ɲ̀ǹítí ~ èǹítí	‘you (sg) come’
	ótó	‘he kills’	ɲ̀ǹótó ~ èǹótó	‘you (sg) kill’
b.	ɓ̀è	‘he/she hit’ (verb root)	ɲ̀m̀é	‘you (sg) hit’
	d̀èmsé	‘he/she sinks’ (verb root)	ɲ̀émsé	‘you (sg) sink’
c.	s̀ùré	‘he/she is sad’ (verb root)	iz̀ùré ~ òz̀ùré	‘you (sg) are sad’

A basic question raised by this data is whether or not to include the nasal in the representation of the 2SG.IMPf. The distributional evidence does not point in one clear direction. Yip (2004) includes the nasal, and proposes that the underlying form for the 2SG.IMPf is èN- ~ NN. A number of rules then derive surface forms. In plosive-initial

roots, this nasal spreads its voicing to the plosive and then deletes. In liquid-initial roots, this nasal undergoes complete assimilation, producing surface geminates. In nasal-initial roots, this nasal undergoes place assimilation.

Within the framework of strength relationships, we might take an alternative point of view, and claim that the underlying form for the 2SG.IMPF excludes the nasal. The nasal which occurs on the surface form is, instead, the result of root lengthening – which now occurs via whole-segment epenthesis of [n]. Under this analysis, a root such as *àlò* ‘tie’ has two variants. The long variant is [náló] because it contains more segments, and the short variant is [àlò] because it contains fewer segments. Thus, the [n] is not contributed by the 2SG.IMPF at all, but by the root itself.

This analysis is, of course, speculative. The details of the surface variation between *èN-* and *NN-* remain to be worked out, as do the assimilation processes that apparently take place in implosive-initial roots. It is perhaps instructive to note, however, that gemination and overt epenthetic segments pattern together in other languages. In Luganda, for example, consonant gemination is a marker of the class 5 prefix when it functions as a nominal prefix in nouns and adjectives: cf. *kkubo* ‘path’, *ttabi* ‘branch’, *ddaala* ‘step’ (data from Clements 1986: 62-63). But roots that begin in a vowel or a pre-nasalized consonant take the segmental prefix *li-* instead: */-ato/* → *lyaato* ‘boat’, */-mpi/* → *liimpi* ‘short’. A traditional analysis would claim that the class 5 prefix has two variants, C and [li], but this does not really capture any principled relationship between the two. Instead, we could say that roots can change in two potential ways, via

gemination or via epenthesis of [li], thus capturing the unifying feature of these changes, which is that they make a root longer.

Velar-initial roots in T^hese present another set of data that I have not analyzed here. These roots undergo a pattern of alternations whose nature is partially, but not entirely, clear to me. In the 1SG.PF, velars delete: *kə̀rù* ‘he/she divides’, *ə̀-áru* ‘I divide’. This can obviously be seen as a form of reduction, just as that which occurs with other plosive-initial roots, although evidence in support of this idea is conflicting. Velar deletion is indeed attested in at least one other morphological context of T^hese, which is the plural prefix, kV-: /kà-káǰá/ →[kà-áǰá] ‘tortoise, PLURAL’. The lexicon, however, contains voiced velars inter-vocalically, as *táǰá* ‘forehead’. Furthermore, the deleted velar is sometimes replaced with a glide that is homo-organic with surrounding vowels, but this appears to be conditioned by high vowels only. Finally, in the 2SG.IMPF, the root-initial velar changes to a voiced geminate, *ḡǰáru* ~ *ǰǰáru* ‘you (sg) divide’. This much can be profitably analyzed within exactly the same framework that we have already proposed for other T^hese roots, because voiced geminates are certainly longer than Ø, but not as long as voiceless geminates. The appearance of the nasal in some variants, however, can only be explained once a general analysis of the appearance of nasals has been developed (and the appearance of a vowel that clearly does not belong to the prefix in other variants, such as the [i] in *ǰǰáru*, remains a mystery).

8. Conclusion

This chapter has provided evidence that, when the morphological environment is held constant, phonological constraints can dictate the surface form of an alternation. Crucially, however, all alternations must be consistently upsizing or downsizing. This predicts that downsizing alternations like deletion and voicing should pattern together, as we saw in Turkish. It also predicts that upsizing alternations should pattern together, as we saw in Northern Sotho, Hungarian, LuGanda, and Choctaw and that compensatory resizing can take place as in Meithei and Ibibio. Finally, it predicts that surface alternations should produce a cline of lengths from shortest to longest, in line with the capacity for contact relationships to impose different degrees of strength on their edges. This prediction is borne out in These.

Chapter 3: Taking some phonology out of morpho-phonology

1. Introduction

In the previous chapter, I examined cases in which morpheme contact relationships were held constant. In the current chapter, I examine cases in which phonological constraints are held constant, which allows us to examine the effect of purely morphological constraints. The theory of morphological strength relationships predicts that, in such cases, morphology can completely determine the surface output. Of course, it is already well-established that morphology crucially interacts with phonology in order to produce surface forms. The novel prediction made by the current theory is that morphological constraints -- specifically, the imperative for one morpheme to upsize or downsize -- have the potential to play the *only* role in producing a phonological form.

In other words, as I will show, there are attested alternations which we cannot model with any known phonological constituent, such as a feature or a timing unit -- even if we associate that constituent to a particular morpheme via diacritics. Furthermore, there are alternations which we cannot model with any known phonological process, such as leftward or rightward spreading -- again, even if we associate spreading with a particular morpheme via diacritics. When phonological considerations under-determine surface outputs in this way, I claim that the grammar is driven by morpheme strength relationships alone, and that the requirement to upsize or downsize a particular morpheme becomes the determining factor for surface length.

It is surely the case that phonological constraints are pervasive throughout human language, and examples in which they under-determine surface outputs are, in fact,

difficult to find. But they do exist. In the sections that follow, I offer three case studies of morphological effects. In the first, from Pări, we will see two suffixes that trigger gemination on verb roots (§2). But the surface result of gemination is different in each case, and the difference cannot be explained by an appeal to phonological features alone. I use allomorphy scales to offer a “feature-free” analysis. In the second case study, from Western Shoshoni, we will see a set of roots that trigger gemination on some suffixes, but not others (§3). This pattern cannot be explained by the presence or absence of an empty timing unit on roots; I analyze it as the result of the presence or absence of a strength relationships. Finally, in the third case study, from Hungarian, we will see that gemination regularly occurs in a specific phonological environment (§4). But the surface result of gemination differs according to the category of the morphemes that are present, and the difference cannot be explained by an appeal to feature spreading. I analyze the different surface outputs as the result of movement along different allomorphy scales.

Thus, there are essentially two mechanisms by which morpheme strength relationships can dictate surface outputs: by determining the degree of movement on a particular allomorphy scale, or by determining which allomorphy scale (if any) is applicable in a given situation. The fact that these mechanisms can operate independently of any phonological constraints reinforces the point that I made, in somewhat different fashion, in the previous chapter: namely that the realization of morphological strength relationships takes precedence over phonological considerations.

2. Degrees of upsizing in Päri

Root-final consonants in Päri verbs undergo a variety of suffix-triggered alternations, which Andersen (1988) refers to as grades. Examples of this consonant gradation are given in bold below, using the root /ŋɔt/ ‘to cut (with an axe)’.

Päri consonant gradation (Andersen 1988: 87-88)

Grade	Suffix	Example	Gloss
1	(none)	yàaɬ á-ŋɔt ùbúrr-ì tree C-cut Ubur-ERG	‘Ubur cut the tree’
2.0	Centripetal	yàaɬ á-ŋú d `-ì ùbúrr-ì tree C-cut-Suf Ubur-ERG	‘Ubur cut the tree (this way)’
	Locative	yàaɬ á-ŋó d `-ì ùbúrr-ì píŋ tree C-cut-SUF Ubur-ERG down	‘Ubur cut the tree down’
2.1	Antipassive	ùbúr á-ŋù d -ò Ubur C-cut-INTR	‘Ubur cut’
3.0	Benefactive	yàaɬ á-ŋú t `-ì ùbúrr-ì ɖáagɔ tree C-cut-SUF Ubur-ERG woman	‘Ubur cut the tree for the woman’
3.1	Antipassive centrifugal	ùbúr á-ŋù t -ò Ubur C-cut-INTR	‘Ubur went to cut’
4.1	Antipassive centripetal	ùbúr á-ŋù nn -ò Ubur C-cut-INTR	‘Ubur came to cut’
	Antipassive benefactive	ɖáagɔ á-ŋù nn -ì ùbúrr-ì woman C-cut-SUF Ubur-ERG	‘Ubur cut for the woman’
5.0	Multiplicative	yín á-ŋó nd `-ì ùbúrr-ì trees C-cut-SUF Ubur-ERG	‘Ubur cut the trees (one by one)’

As can be seen from the examples, Grade 1 occurs word-finally. The remaining grades are triggered by particular suffixes. Grade 2.0 occurs with the centripetal and locative suffixes (shown), as well as the first singular, third singular, and first plural inclusive (not shown). Grade 2.1 occurs with the antipassive. And so on.

The patterns shown for /ɲɔt/ ‘cut’ are just one part of a larger pattern that includes stop-final, nasal-final, and approximant-final roots. The table below, from Andersen (1988: 85), will be the focus for our subsequent discussion of Pāri; empty slots in the table indicate that relevant data are missing.

1	2.0	2.1	3.0	3.1	4.0	4.1	5	6
p	b		p		mm		mb	p
<u>t</u>	<u>d</u>		<u>t</u>		<u>nn</u>		<u>nd</u>	<u>t</u>
t	d		t		nn		nd	t
c	y		c		ɲɲ		ɲj	c
k	∅		k		ɲɲ		ɲg	k
m	m		mb		mm		mb	m
<u>ɲ</u>	<u>ɲ</u>		<u>nd</u>		<u>nn</u>			<u>ɲ</u>
n	n		nd		nn			n
ɲɲ	ɲɲ		ɲj		ɲɲ		ɲj	ɲɲ
ɲ	ɲ		ɲg		ɲɲ			ɲ
r	r	d	yy	t	rr	nn	yy	r
l	l	d	nd	t	ll	nn	nd	l
y	y		yy			ɲɲ ⁴		y
w	w		ww		ww	mm ww		w

As seen in the table, consonant gradation Pāri presents us with several interesting problems that I will address in subsequent sections:

1. Grade 1: The consonant variants which occur in Grade 1, with unsuffixed simple stems, also occur in Grade 6, with the second person singular and focus suffixes.

This is not so much a problem as a useful starting point for our analysis.

2. Grades 2.0 and 2.1: Non-velar stop consonants are voiced, while the velar stop is deleted. The puzzle, which should be familiar by now, is why a feature-based

⁴ Andersen lists [yy] in this cell of the table. However, the examples that he gives of [y]-final roots all surface with [ɲɲ] in this grade, suggesting that the table contains a typo.

alternation patterns with a segment-based one; a preliminary analysis of this was presented in Chapter 1.

3. Grades 3.0 and 3.1: The nasals alternate to nasal-stop clusters. The puzzle is why, under the same conditions, the oral stops do not alternate at all.
4. Grades 5.0 and 5.1: Not just nasals, but *all* consonants alternate to nasal-stop clusters, except the sonorant [yy]. The puzzle is that, from a featural perspective, this outcome requires [+nasal] to be inserted in some instances, but [-continuant] to be inserted in others. (And furthermore, it requires neither to be inserted for the approximant [yy]).
5. Grades 4.0 and 4.1: All consonants alternate to nasal geminates, except the sonorants [rr, ll, ww] in Grade 4.0. The puzzle is how to account for the lack of nasality in just these cases, but the presence of nasality everywhere else.

Recall our primary goal in this chapter, which is to demonstrate that morpheme contact relationships can determine surface alternations entirely on their own, as Resizing Theory predicts. In other words, I want to show how an appeal to overall morpheme size can free us from some -- although certainly not all -- of the trappings of feature-based and segment-based phonology. For this goal, three of the six Pāri problems outlined above are most pertinent: voicing and velar deletion in Grades 2.0 and 2.1, nasal-stop clusters in Grades 5.0 and 5.1, and nasal gemination in Grades 4.0 and 4.1. For each of these problems, Resizing Theory offers an analysis that helps to unify the apparent proliferation of features and segments occurring in each of the grades. In order to provide as comprehensive analysis as possible, however, we must also address the alternations that occur in the other grades. I therefore build an analysis of Pāri in a step-by-step

fashion, beginning with Grade 1, highlighting those facts which are most pertinent to Resizing Theory.

2.1 Overview of Pāri

Pāri has twenty consonant phonemes, which are fully contrastive only in stem-initial position.

p	t̪	t	c	k	ʔ
b	d̪	d	j	g	
m	n̪	n	ɲ	ŋ	
		l			
		r			
w			y		

Glottal stop does not occur stem-finally, the voiced stops do not occur word-finally, and there is no contrast between [j] and [y] in stem-final position.

Pāri has twenty-four vowel phonemes, which include short and long vowels as well as diphthongs.

Monophthongs

i, ii	u, uu
ɪ, ɪɪ	ʊ, ʊʊ
e, ee	o, oo
ɛ, ɛɛ	ɔ, ɔɔ
	ʌ, ʌʌ
	a, aa

Diphthongs

ie	uo
ɪɛ	ʊɔ

Pāri also has contrastive tone, discussed briefly in Andersen 1988: 64-66.

A Pări word consists of at most four concatenative morphemes, arranged as follows:

Prefix-Stem-Suffix-Enclitic

The stem shape is C(w)V(V)(C) and consists of three parts. The initial part is either a consonant, or a consonant followed by the glide /w/. The medial part is either a short or long vowel, or a diphthong. The final part is either a consonant, a cluster of two consonants, or zero. A cluster can occur only if the stem is followed by a suffix vowel, never word-finally. Permitted consonant clusters include sequences of homorganic nasal plus voiced stop, and geminate sonorants. Affixes and enclitics do not have consonant clusters, and their vowels are short.

2.2 Starting points: Grades 1 and 6

Grade 1 represents the variant of the root-final consonant that occurs in simple, unsuffixed stems. These variants are identical to those of Grade 6, which occur with the second person singular suffix and the focus suffix.

Pări Grades 1 and 6 (Andersen 1988: 98)

Grade 1 (Simple stem)	Grade 6 (2SG)	Gloss
tùuk`	túuk-í`	‘play’
yùom`	yúom-í`	‘rest’
mìel`	míel-í`	‘dance’
tíer`	tíer-í`	‘quarrel’
yíey`	yíey-í`	‘accept’
thùow`	thúow-í`	‘get dry’

These data suggest two things: first, that the starting point for movement along the root size scales should be located at the Grade 1 variant, because no strength relationship is operative here (we will make use of these starting points in subsequent sections); and second, that the second person singular and focus suffixes are neither stronger nor weaker than the root morphemes to which they attach, and therefore trigger no movement along the scales.

Roots	■	Grade 6 suffixes
-------	---	------------------

“The boundary between roots and Grade 6 suffixes requires no strengthening or weakening on either side.”

This is a default contact relationship, symbolized with a square, that has no consequence for surface alternations. In general, there is no need to make explicit such a relationship except when comparing it to other contact relationships that *do* have surface consequences, as we are doing here.

I have used “Grade 6 suffixes” as a cover term for the class of suffixes that trigger Grade 6 alternations, namely the second person singular and focus, and I will use similar cover terms in the sections to follow.

2.3 Voicing and velar deletion: Grades 2.0 and 2.1

In Grades 2.0 and 2.1, non-velar stop consonants are voiced, while the velar stop is deleted, as shown in the following data, repeated from Chapter 1 (recall that the consonant variants in Grade 2.0 are triggered by the first person singular, third person singular, locative, and centripetal morphemes; those in Grade 2.1 are triggered by the antipassive).

Päri Grades 2.0 and 2.1 (Andersen 1988: 91)

Final C	Root	Grade 2.1 (Antipassive)	Gloss
/p/	yap	yλb-ò	‘open’
	lɔp	lûub-ó	‘speak’
/t̥/	t̥uʈ	t̥uʈ-ò	‘pierce’
	riʈ	riʈ-ó	‘sew’
/t/	kλt	kλd-ò	‘plait’
	puot	pòod`-ò	‘beat’
/c/	kac	kλy-ò	‘bite’
	tuoc	toòy`-ò	‘tie’
/k/	yɪk	yì-ò	‘make’
	lɔk	lò-ò	‘wash’

Although this is a familiar alternation from a historical perspective, it remains a puzzling one from a synchronic perspective. The addition of voicing to a consonant is traditionally viewed as a featural alternation, while the deletion of a velar stop is viewed as a segmental one.

The analysis of this data that I presented in Chapter 1 used the following contact relationship.

Roots < Grade 2.0 & 2.1 suffixes

“The boundary between roots and Grade 2.0 & 2.1 suffixes requires a relative weakening on its left side and/or a relative strengthening on its right.”

This relationship drives downsizing movement on the root size scales. For roots that end in non-velar stops, such as /kλt/ ‘plait’, the surface result is voicing. For roots that end in velar stops, such as /yɪk/ ‘make’, the surface result is deletion.

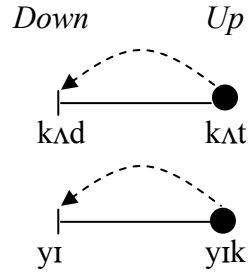

Roots that end in sonorant consonants do not have shorter variants, and therefore undergo no movement: cf. Grade 1 *cwɪŋ*, Grade 2.1 *cwɪŋ-o* ‘light’.

●
cwɪŋ

We will be adding additional points to these preliminary size scales as we consider further grades. I have not yet accounted for the fact that root-final /ɾ/ and /l/ alternate to [d] in Grade 2.1 (but not 2.0); I will consider this in a subsequent section.

Päri Grade 2 suffixes are thus an example of how voicing and velar deletion act in concert, bearing out the prediction that downsizing alternations should pattern together. Furthermore, in the context of this chapter, the Grade 2 suffixes are an example of an alternation that can technically be handled by traditional phonological constituents, but only in an awkward way. We could, for example, associate Grade 2 suffixes with a feature [+voice] that docks onto root-final consonants. Then an additional rule would be needed to delete voiced velars. As an alternative, Resizing Theory places the locus of the change on the morphology, rather than on phonological diacritics, and as such does away with the formal distinction between voicing and deletion.

2.4 Nasal-stop clusters: Grades 3.0 and 3.1

In Grades 3.0 and 3.1, the nasals alternate to nasal-stop clusters.

Päri Grades 3.0 and 3.1 (Andersen 1988: 91)

Final C	Root	Grade 3.1 (Antipassive centrifugal)	Gloss
/m/	cam	cλmb-ò	‘open’
	pɪɛm	pɪemb-ò	‘discuss’
/n/	ɲɪn	ɲɪnd-ò	‘rub’
	kwaan	kwλλnd-ò	‘count’
/ɲ/	cwɪɲ	cwɪɲj-ò	‘light’
	kɔɔɲ	kùɲj-ò	‘dig’
/ŋ/	kaŋ	kλŋg-ò	‘hoe’
	waan	wλλŋg-ò	‘burn’

The puzzle is why, under the same conditions, the oral stops do not alternate at all: cf.

yλp-ò ‘open’, *tùt-ò* ‘pierce’, *kλt-ò* ‘plait’, *kλc-ò* ‘bite’, *yik-ò* ‘make’.

This particular puzzle is, I think, best resolved with traditional phonological constituents, namely the addition of the feature [-continuant], introduced diacritically by Grade 3 suffixes. This feature is already present for oral stops, explaining their lack of alternation. This feature gets added to nasal stops, producing nasal-stop clusters. This analysis can also explain the alternations that root-final /r/ and /l/ undergo in Grade 3.1.

Päri Grade 3.1 (Andersen 1988: 91)

Final C	Root	Grade 3.1 (Antipassive centrifugal)	Gloss
/r/	par	pλt-ò	‘think’
	gɛɛr	gèet-ò	‘build’
/l/	kwal	kwλt-ò	‘steal’
	cɔul	cùt-ò	‘pay’

In general, the presence or absence of a manner feature should have no effect on the arrangement of size scales. This is because manner changes are neither upsizing nor downsizing; that is, they do not affect the overall length of a morpheme in the way that, say, voicing changes can. This allows us to treat the feature [-continuant] in a way that is essentially independent from the operations of resizing. The proposal that Grades 3.0 and 3.1 have a feature-based explanation is not entirely without consequences for Resizing Theory, however. There is some evidence that the presence of [-continuant] and the operation of upsizing can trade off with one another. For example, in Grades 3.0 and 3.1, root-final /y/ and /w/ do not alternate to a stop, but geminate instead.

Päri Grades 3.0 and 3.1 (Andersen 1988: 91)

Final C	Root	Grade 3.1 (Antipassive centrifugal)	Gloss
/y/	dɔɔy	dòoyy-ò	‘weed’
/w/	ŋɛɛw	ŋɛɛww-o	‘buy’

This pattern is not completely at odds with cross-linguistic evidence, referred to in Chapter 1, suggesting that maximum stricture and length tend to co-occur (Elmedlaoui 1993, Kirchner 2000, Podesva 2002). Further refinements to Resizing Theory would be necessary in order to model this trade-off; one possibility is the addition of a scale representing not size, but degree of closure, which could interact on a second dimension with size scales.

We have not yet accounted for the alternations that rhotics and liquids undergo in Grade 3.0 (versus 3.1, which is straightforward); these make more sense after we have considered Grade 5 more fully.

2.5 Nasal-stop clusters: Grade 5

Grade 5 is similar to Grades 3.0 and 3.1, except that here, *all* attested consonants alternate to nasal-stop clusters.

Päri Grade 5 (Andersen 1988: 89)

Final C	Grade 1 (Unaffixed)	Grade 5 (Multiplicative)	Gloss
/p/	á-yàp	á-yáamb`-ì	‘open’
/t̥/	á-n̥òt̥	á-n̥óond̥-ì	‘suck’
/t/	á-kàt	á-káand`-ì	‘plait’
/c/	á-kàc	á-káanj`-ì	‘bite’
/k/	á-yík`	á-yìng-ì	‘make’
/m/	á-càm	á-cáamb`-ì	‘eat’
/ɲ/	á-cwìɲ	á-cwíɲj`-ì	‘light’
/l/	á-kwàl	á-kwáand`-ì	‘steal’

The one exception is the rhotic /r/ which, according to the table of grades in Andersen (1988: 89), alternates to [yy], although unfortunately no example of this alternation is given in the subsequent text. Note too that, as indicated by the empty slots in the table of grades, relevant data are lacking for roots ending in /n̥, n, ɲ, y, w/.

The puzzle here is somewhat different from the one that we faced in Grades 3.0 and 3.1. If we take a strictly a featural perspective, the Grade 5 outcome requires [+nasal] to be inserted onto oral stops, but [-continuant] to be inserted onto nasal stops. Furthermore, it requires that both features be inserted onto the liquid /l/. An output-oriented approach, such as Optimality-Theory (McCarthy & Prince 1993) could presumably solve much of this problem with a markedness constraint, specific to Grade 5 morphemes, that penalizes any output that is not a nasal-stop cluster. This approach would face two problems, however. The first problem is the Grade 5 alternation /r/ →

[yy], which does not produce anything resembling a nasal-stop cluster. The second problem is that this approach would then require an entirely separate explanation for alternations in the other grades.

Within Resizing Theory, the point of departure for an analysis of Grade 5 is the observation that nasal-stop clusters are longer than either individual stops or individual nasals. That is, [nd] has two segments and is therefore longer than either [t] or [n], respectively. We can therefore integrate these clusters into the linear arrangement of the size scales, as shown below for roots ending in both oral stops and in nasal stops.

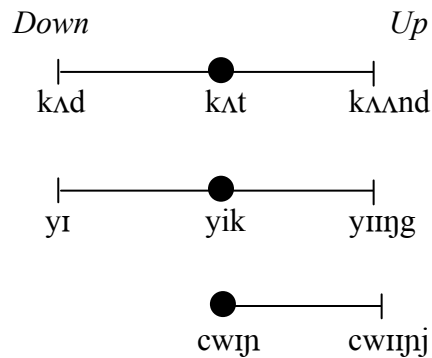

Movement toward the upsizing end of the scale is triggered by a contact relationship between roots and Grade 5 suffixes.

Roots > Grade 5 suffixes

“The boundary between roots and Grade 5 suffixes requires a relative strengthening on its left side and/or a relative weakening on its right.”

I hypothesize for the moment that this relationship motivates a one-point movement, as follows:

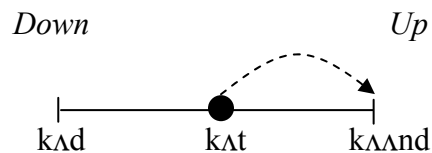

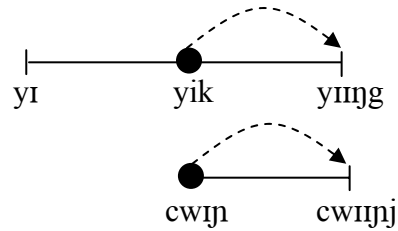

In other words, the Grade 5 suffixes have the effect of increasing the length of the root that they attach to, by adding a segment. Viewing the alternation in terms of relative size, rather than in terms of features, frees us from worrying about the apparent disparity in feature insertion ([nasal] in some cases, [-continuant] in others). Furthermore, it allows us to insert both features just in those cases where it is needed, namely in the alternation /l/ → [nd].

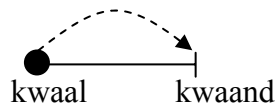

Viewing the alternation in terms of relative size also permits us to integrate the /r/ → [yy] alternation into the analysis. Changing to a geminate approximant is simply an alternative means of increasing root size. Under Resizing Theory, we need not worry about the fact that this alternation involves neither [nasal] nor [-continuant]; it is still unified with the other Grade 5 alternations by the upsizing that it exhibits.

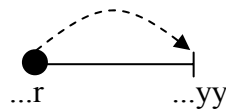

There is one final point to be made concerning a connection between alternations in Grade 5 and Grades 3.0 & 3.1. For root-final nasals, a one-point upsizing movement in Grade 5 brings them to a nasal stop cluster such as [nd], which is of course identical to

that of Grade 3.0 & 3.1, where we attributed this output to the addition of the feature [-continuant]. In other words, in one instance the output [nd] results from resizing, but in another instance it results from a feature diacritic. Interestingly, there is evidence that Pāri speakers may have reanalyzed portions of the Grade 3.0 & 3.1 paradigm as a resizing operation. In Grade 3.1, /r/ and /l/ both surface as [t], which is in line with the prediction that [-continuant] has been added. In Grade 3.0, however, /r/ and /l/ surface as [yy] and [nd], respectively. These outputs are identical to the resizing outputs of Grade 5, suggesting that speakers have noticed the large degree of overlap between these two grades.

2.6 Nasal geminates: Grades 4.0 and 4.1

In Grades 4.0 and 4.1, all consonants alternate to nasal geminates. The exception is the sonorants [r, l, w], which alternate to non-nasal geminates [rr, ll, ww] in Grade 4.0 only. Data for stops, nasals, and non-nasal sonorants is shown below.

Stops in Grades 4.0 and 4.1 (Andersen 1988: 91, 93-94)

	Root	Grade 4.0 (Ingressive)	Root	Grade 4.1 (Centripetal Antipassive)
/p/	--	--	yap 'open'	yλmm-ò
			lɔp 'speak'	lùumm-ò
/t̥/	b̥t̥` 'be sharp'	b̥ɪ̃nn̥-ò	t̥t̥ 'pierce'	t̥ù̃nn̥-ò
	fĩt̥` 'be hot'	fĩɪ̃nn̥-ò	rĩt̥ 'sew'	rĩĩnn̥-ò
/t/	m̥it` 'be delicious'	m̥ĩnn-ò	kλt 'plait'	kλnn-ò
	yòot` 'be light'	yòoonn-ò	puot 'beat'	pòonn-ò
/c/	ɲìc̥ 'be cold'	ɲĩɲɲ-ò	kac 'bite'	kλɲɲ-ò
	ràac̥ 'be bad'	rĩɲɲ-ò	tuoc 'tie'	tòɔɲi-ò
/k/	jλlk` 'be lazy'	jλɲɲ-ò	yik 'make'	ỹiɲɲ-ò
	pèek` 'be heavy'	pèeɲɲ-ò	luok 'wash'	lòoɲi-ò

Nasals in Grades 4.0 and 4.1 (Andersen 1988: 91, 93-94)

	Root	Grade 4.0 (Ingressive)	Root	Grade 4.1 (Centripetal Antipassive)
/m/	yòòm` 'be soft'	yòomm-ò	cam 'eat'	càmm-ò
	ṭɛɛm` 'be tasteful'	ṭɛemm-ò	p̣iɛm 'discuss'	p̣iemm-ò
/ŋ/	ṭiŋ` 'be few'	ṭiŋŋ-ò	--	--
	ṭiŋŋ` 'be small'	ṭiŋŋŋ-ò		
/n/	cààn` 'be near'	càann-ò	ɛn 'rub'	ɛnn-ò
	ɟààn` 'be new'	ɟàann-ò	kwaan 'count'	kwàann-ò
/ɲ/	ḍɲɲ` 'be narrow'	ḍɲɲ-ò	cwɲ 'light'	cwɲɲ-ò
	wàaɲ` 'be clean'	wàaɲ-ò	kɔɔɲ 'dig'	kùɲɲ`-ò
/ŋ/	ḍòɔŋ` 'be big'	ḍòɔŋ-ò	kaŋ 'hoe'	kàŋ-ò
			waɔŋ 'burn'	wàaŋ-ò

Non-nasal sonorants in Grades 4.0 and 4.1 (Andersen 1988: 91, 93-94)

	Root	Grade 4.0 (Ingressive)	Root	Grade 4.1 (Centripetal Antipassive)
/r/	mòr` 'be warm'	mùrr-ò	par 'think'	pànn-ò
	bèèr` 'be good'	bèerr-ò	gɛɛr 'build'	gèenn-ò
/l/	còl` 'be black'	cùll-ò	kwal 'steal'	kwànn-ò
	pòol` 'be blunt'	pòoll-ò	cɔɔl 'pay'	cùnɲ`-ò
/w/	p̣iɛw` 'be fast'	p̣iɛww-ò	ɛɛw 'buy'	ɛèemm-ò
/y/	--	--	ḍɔɔy 'weed'	ḍòɔŋ-ò

The basic pattern, then, is one of nasal gemination everywhere except for /r, l, w/ in Grade 4.0, where plain gemination occurs instead (no data is available for /y/ in Grade 4.0). The puzzle is how to account for the lack of nasality in just these cases, but the presence of nasality everywhere else.

2.6.1 Feature-based analysis of Grades 4.0 and 4.1

Crucially, the difference in output cannot be attributed only to a difference in the phonological make-up of the Grade 4.0 and Grade 4.1 suffixes. A traditional analysis of Pāri might propose that both types of suffix contain an empty timing unit, here represented as X. This accounts for gemination in both grades. The key difference between these morphemes, however, would lie with the [Nasal] feature, which would be absent for Grade 4.0 but present for 4.1. The following table shows how such an analysis might work.

	Underlying representation	Sample derivation	Output
Grade 4.0	/X/	<pre> XXX-X \ m o r </pre>	→ mùrr- ‘be warm’
Grade 4.1	<pre> [NASAL] /X/ </pre>	<pre> [NASAL] \ XXX-X \ p a r </pre>	→ pànn- ‘think’

This analysis works well for the sonorant-final roots such as /mòr-/ ‘be warm’ and /par/ ‘think’, which are distinguished by the absence or presence of nasality on the geminates in the output. As we have already seen however, this analysis falls short for the roots

ending in voiceless stops. These stops alternate to nasal geminates in both paradigms, but the analysis predicts that they should do so only in Grade 4.1.

2.6.2 Resizing Theory analysis of Grades 4.0 and 4.1

The analysis that I propose consists of two parts: a morpheme contact relationship and a traditional feature diacritic.

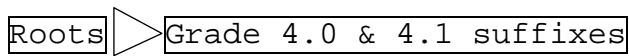

“The boundary between roots and Grade 4.0 & 4.1 suffixes requires a lot of relative strengthening on its left side and/or relative weakening on its right.”

Phonological feature diacritic for Grade 4.1 = [NASAL]

The feature [NASAL] plays a role as it would in a traditional analysis, crucially distinguishing Grade 4.0 suffixes (where nasality is absent) from Grade 4.1 suffixes (where nasality is present). But the difference in Resizing Theory is that the feature [NASAL] plays no role at all in the alternation between stops and nasal geminates in Grade 4.0.

The point of departure for this idea is the observation that nasal geminates are longer than either individual stops or individual nasals. That is, [nn] has two segments and is therefore longer than either [t] or [n], respectively. We can integrate these geminates into the linear arrangement of the size scales that we have proposed in previous sections, as shown below for roots ending in both oral stops and in nasal stops.



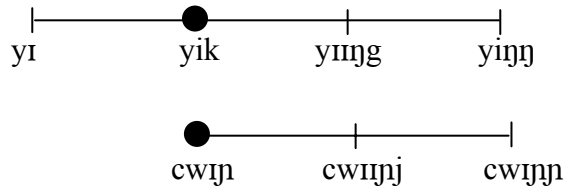

By hypothesis, a geminate such as [nn] is longer than a cluster such as [nd], but nothing crucial hinges on this assumption. We could offer a nearly identical analysis by hypothesizing that [nd] is longer than [nn].

The key thing to note about the size scales is that they essentially allow us to ignore the presence of nasality. This is because it operates according to a single criterion: length. The points on the scale may happen to be further differentiated, as they are here, by things like nasality, but these do not play any role in either the construction of the scale or in movement from one point on the scale to another. In other words, the size scale conceives of the alternation between singleton voiceless stops and nasal geminates as an alternation of upsizing alone.

Roots ending in /r, l, w/ have two geminate variants, non-nasalized and nasalized. Because they are both geminates, there is no reason to believe that they differ in length. Rather, they differ only in terms of their nasality. The non-nasal and nasal geminate variants therefore occupy the same position on the size scale. An example of an /l/-final root is below.

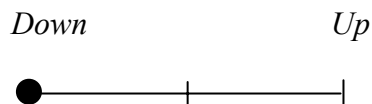

kwaal kwaand kwΛnn
 kwΛll⁵

For both Grades 4.0 and 4.1, movement to the upsizing end of the scale is triggered by a contact relationship.

Roots ▷ Grades 4.0 and 4.1 suffixes

“The boundary between roots and Grade 4.0 & 4.1 suffixes requires a lot of relative strengthening on its left side and/or relative weakening on its right.”

Notice that this contact relationship exists along a cline with the relationship that we previously proposed, Roots ▷ Grade 5 suffixes. That is, the relationship triggered by Grade 5 is only mildly lopsided, while the relationship triggered by Grade 4 is identical but more severely lopsided. Therefore, it has the effect of triggering a greater degree of movement on the size scales. I hypothesize that this relationship motivates an end-point movement, as follows:

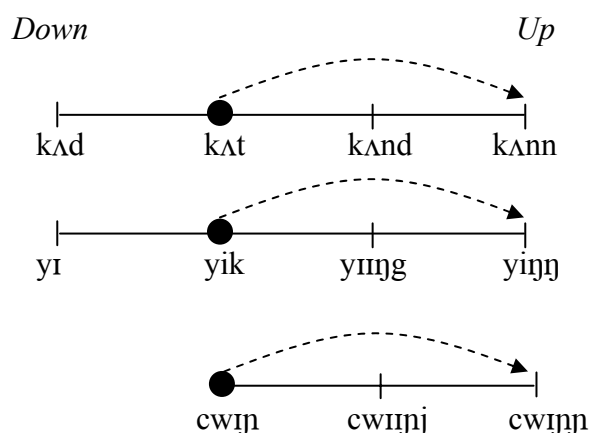

⁵ The variant [kwΛll] is consistent with Andersen’s (1988) description but does not actually appear in his text, which uses other /l/-final roots to demonstrate the effects of Grade 4.0.

Scalar movement for roots ending in /r, l, w/ takes place in exactly the same way; the only difference is that the upsizing endpoint of the scale contains two equal-sized variants, instead of just one.

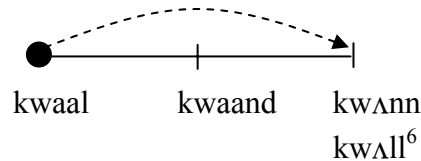

Here, and only here, the feature [NASAL] exerts itself. When the Grade 4.1 suffixes introduce this feature via diacritics, the nasal variant surfaces (i.e., [kwΛnn] in the example above). When, as in Grade 4.0 suffixes, this feature is absent, the non-nasal variant surfaces (i.e., [kwΛll]).

As with the manner feature that I employed in Grades 3.0 and 3.1, the presence or absence of a nasality feature should have no effect on the arrangement of size scales. This is because changes in nasality are neither upsizing nor downsizing; that is, they do not affect the overall length of a morpheme in the way that, say, voicing changes can. This allows us to treat the feature [NASAL] in a way that is independent from the operations of resizing.

Thus, in the analysis that I have offered, the phonological feature [NASAL] still plays a role. The difference, however, is that this feature is not *obliged* to be active everywhere that nasality happens to occur on the surface. Instead, certain cases of nasality are reanalyzed as merely a means to an end: that is, nasal gemination offers a

⁶ The variant [kwΛll] is consistent with Andersen's (1988) description but does not actually appear in his text, which uses other /l/-final roots to demonstrate the effects of Grade 4.0.

way for voiceless stops to upsize, and it is therefore the length of these segments (and only the length) which is active during word-building.

2.6.3 Motivation for upsizing via nasalization

Why do voiceless stops in Pāri upsize in this particular way? Why don't voiceless stops simply undergo gemination to become [pp, tt, kk]? This answer has to do with the distribution of length contrasts in the language. In Pāri, any consonant in stem-final, word-medial position may be phonetically short or long (except voiced stops, which are always phonetically short). However, the difference between short and long durations is contrastive only for sonorants. This is because voiceless stops obey a rhythmic rule in which they are realized as short after a long vowel or diphthong, but realized as long after a short vowel (Andersen 1988: 69-71, examples from page 71, C=COMPLETIVE, M = MULTIPLICATIVE).

ά-λύου̐ -έ C-speak-3P	[aloupe]	‘they spoke it’
ά-λύου̑ -έ C-speak.M-3S	[aluppe]	‘he spoke it’
ά-ηού̐ -ή C-show-2S	[aηou̐i]	‘you showed it’
ά-ηού̑ -ή C-show.M-2S	[aηutti]	‘you showed it’
kiit-à stones-1S	[kiita]	‘my stones’
kit-à stone-1S	[kitta]	‘my stone’
ά-ρούου̐ -έ C-rub-3P	[aruuce]	‘they rubbed it’
ά-ρούου̑ -έ C-rub.M-3S	[arucce]	‘he rubbed it’
ά-εδο̐κ-έ C-deceive-3S	[acɔɔke]	‘he deceived him’
ά-εδο̑κ-έ C-smash-3P	[acɔkke]	‘they smashed it’

So if voiceless stops were to upsize by becoming voiceless geminate stops ($t \rightarrow tt$, $t̥ \rightarrow t̥t̥$, etc.) this effect would be neutralized by the rhythmic rule. After any long vowel, the morphologically-created geminate would shorten to a singleton. After any short vowel, a phonologically-created geminate would already be present, making the morphological effect of upsizing redundant. In other words, the contact relationship requiring upsizing of the root would simply have no way to manifest itself on the surface.

If voiceless stops upsize by becoming nasal geminates, however, this problem does not arise. Although the behavior of stops suggests that syllable isochrony is operative in the language, the behavior of sonorants defies this. This is shown in the examples below, where a contrast between short and long sonorants is maintained after both short and long vowels (Andersen 1988:69-70).

ùbímm-ì N-2S	‘your gibbon’	ùbímm-ì N-ERG	‘gibbon’
kóòm-ì N-P	‘chairs’	kóomm-ì N-ERG	‘chair’
á-ɲààɲ-é C-V+CENTRIP-3S	‘He moved it’	á-ɲààɲɲ-é C-V+BEN+AP-3S	‘He moved (sth) for him’
ɖáàɲ-é` N-ERG	‘person’	ɖáàɲɲ-è N-3S	‘his person’
ɲìnn-ò V+AP-INTR	‘He is rubbing’	ɲìnn-ò V+CP+AP-INTR	‘He is coming to rub’
jwáàn -í N-2S	‘your hut’	jwáann -í N-P	‘huts’
kùɲì -ò V+AP-INTR	‘He is digging’	kùɲɲì -ò V+CP+AP-INTR	‘He is coming to dig’
pòɔɲì -ò V+AP-INTR	‘He is teaching’	pòɔɲɲì -ò V+CP+AP-INTR	‘He is coming to teach’
tóɲ-ì N-2S	‘your spear’	tóɲɲ-ì N-ERG	‘spear’
kòɔɲ -ò N-S	‘beer’	kòɔɲɲ -ó` N-1PINCL	‘our beer’
múgwár-ì N-2S	‘your zebra’	múgwárr-ì N-ERG	‘zebra’
cùurr-í` N-DEM	‘this vulture’	cùurr-ì N-ERG	‘vulture’
pàl` -è N-ERG	‘knife’	pàll` -è N-3S	‘his knife’
bòoll-ì N+P-ERG	‘handles’	bòoll-ì N-ERG	‘handle’
káww-à N-1S	‘my bamboo’	káww-à N+P-1S	‘my bamboos’
á-láaw` -é C-V-3S	‘He washed it’	á-láaww` -é C-V-3P	‘They washed it’
búyy-ì N-2S	‘your net’	búyy-ì N-ERG	‘net’
ù-dòyy-ó RES-V-SUF	‘It has been weeded’	ù-dòyy-ó RES-V+M-SUF	‘It has been weeded (repeatedly)’

Nasality, therefore, is simply a means to an end: it allows upsizing to occur, but it has no featural presence in and of itself. The allomorphy scales proposed above, which

disregards featural content and arranges variants solely on the basis of length, captures this idea.

2.6.4 Scales and inventory constraints

Size scales are designed to include all variants of a particular morpheme. In the case of stop-final roots in Päri, the size scales omit variants that might otherwise be expected to occur: namely, variants ending a voiceless geminate stop such as [tt]. This variant is expected to occur because nasal-final and approximant-final roots undergo simple gemination in order to lengthen in Grade 5, suggesting that stop-final roots ought to undergo simple gemination as well. The fact that they do not is a statement about the inventory of Päri: voiceless geminates are not contrastive in the language, although importantly, they do occur on the surface as an automatic consequence of the rhythm rule discussed above. The question that arises is whether the size scales can take the place of inventory constraints, or whether such constraints still need to be separately and redundantly posited.

I would like to suggest that, in a fully developed Resizing Theory, size scales should be able to obviate the need for separate inventory constraints. That is, the size scales of a language will consist both of a statement about what variants do and do not occur, and an ordering of those variants along particular dimensions. Now, in its current stage of development, Resizing Theory is not quite capable of taking on this task. Let us return to the example of stops alternating with nasal geminates in Päri. A size scale like the following, for the root /kʌt/, lacks a variant ending in a voiceless geminate stop, *[kʌtt].

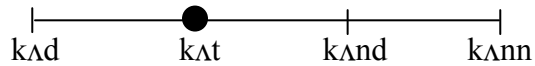

The scale thus captures the fact that no morpheme contact relationship produces *[kΛtt].

If we were to generalize over the scales for all stop-final roots in the language, we would capture the fact that no morpheme contact relationship produces voiceless geminate stops *[pp, tt, tt̥, kk, cc].

There are, however, other alternations in the language that produce surface [pp, tt, tt̥, kk, cc]. According to the rhythm rule, singleton voiceless stops alternate automatically to geminates after a short vowel, cf. [aluppe] ‘he spoke it’, [aɲu^{tt̥}ti] ‘you showed it’, etc. This is a statement about the inventory of Pāri, and it needs to be captured somehow. Resizing Theory could potentially do this by positing a contact relationship, not between morphemes, but between adjacent vowels and consonants.

v < C

“The boundary between a vowel and the following consonant requires a relative weakening on its left side and/or a relative strengthening on its right.”

The contact relationship triggers upsizing movement along the consonant scale.

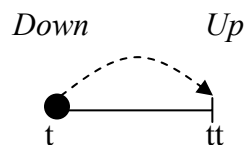



Note that the relevant scale is an arrangement not of entire morphemes, but of individual consonant segments. Scales such as this would capture the fact that voiceless geminate stops are indeed in the surface inventory.

Because this study has focused on length alternations and morpheme contact relationships, it has excluded other alternations, such as Päri’s rhythm rule, which would be relevant for gaining a full picture of surface inventory constraints. Therefore, the claim that Resizing Theory can replace inventory constraints is still speculative, and awaits further evidence. If, however, Resizing Theory can replace such constraints, it will do so in a significantly enriched manner. That is, Resizing Theory would encapsulate information not just about the mere existence of surface variants, but about their source.

2.7 Summary

Here is a summary of the analysis that I have developed for Päri.

Grade	Contact relationship	Diacritic feature	Representative root-final alternations
1.0	(none)		--
2.0	Roots \triangleleft Grade 2		<i>Downsizing:</i> p → b k → ∅
3.0	(none)	[-continuant]	p → p k → k m → mb l → t
3.1	(none), analogy to Grade 5		l → nd
5	Roots \triangleright Grade 5		<i>Upsizing, one-point:</i> p → mb k → ŋk m → mb l → nd r → yy

Grade	Contact relationship	Diacritic feature	Representative root-final alternations
4.0	Roots  Grades 4.0 & 4.1		<i>Upsizing, end-point:</i> p → mm k → ŋŋ m → mm l → ll
4.1	Roots  Grades 4.0 & 4.1	[NASAL]	<i>Upsizing, end-point:</i> p → mm k → ŋŋ m → mm l → nn
6	(none)		--

The key message here is that the morpheme contact relationships do much of the work that phonological constituents cannot do by themselves. They unify featural and segmental alternations in Grades 2.0 & 2.1. They unify conflicting feature diacritics in Grade 5. And they explain the near-total dominance of nasal geminates in Grades 4.0 and 4.1. Note finally that the simple downsizing analysis of Grades 2.0 & 2.1, which I initially developed in Chapter 1, integrates very well into an overall picture of Pāri in which alternations are, first and foremost, size-based.

2.8 Remaining issue

I have aimed to offer a comprehensive analysis of consonant alternations in Pāri. One piece of data that I have not accounted for, however, has to do with the alternations of /r/ and /l/ to [d] in Grades 2.1. This would seem to be due to the presence of a [-continuant] feature, but there is no additional evidence in this paradigm to support such a feature. I leave this problem open for future research.

3. Upsizing and (non)-upsizing in Western Shoshoni

The examples from Pāri demonstrate one way in which morphological constraints can determine surface outputs: namely, by ignoring featural changes in an attempt to upsize by any means available. There is another way in which morphological constraints can determine outputs: by determining *which* contact relationship, if any, is operative for any given context, and thus which scales will exhibit movement. In this section, we examine data from Western Shoshoni (Crum & Dayley 1993) which show that the choice between contact relationships which are simultaneously active can determine surface forms even in the face of under-determined phonological constraints.

The basic puzzle that this language presents comes from the verbal paradigm, where certain verb roots, such as *hima-* ‘carry, take-PLURAL’, trigger gemination of the initial consonant of a following suffix.

hima- ‘carry, take-PLURAL’			
-taippeh	COMPLETIVE	→ himattaippeh	‘taken completely’
-kan	STATIVE	→ himakkan	‘hold’
-ten	PRES. PARTICIPLE	→ kai himaten	‘not take’

Thus, gemination occurs with the suffixes *-taippeh* ‘COMPLETIVE’ and *-kan* ‘STATIVE’, as well as most other suffixes. Yet for some reason, this otherwise regular gemination fails to occur with a small handful of suffixes, such as *-ten* ‘PRES. PARTICIPLE’.

The exceptional behavior of suffixes like *-ten* also shows up with other verb roots, such as *etein-* ‘be hot’.

etein- ‘be hot’			
-taippeh	COMPLETIVE	→ eteihtaippeh	‘completely hot’
		[θ]	

-kan	STATIVE	→ etei <u>h</u> kan [ɣ]	‘be hot’
-ten	PRES. PARTICIPLE	→ etei <u>n</u> ten [nd]	‘being hot, heat’

With most stop-initial suffixes, *etein-* ‘be hot’ produces a voiceless fricative on the surface, represented as a sequence of *h* + C in the orthography. But in combination with *-ten*, *etein-* produces a sequence of nasal plus voiced stop instead.

In the sections that follow, we will see how the theory of morpheme strength relationships handles this puzzle, and how Western Shoshoni provides evidence for the prediction that contact relationships alone can dictate surface forms.

3.1 Overview of Western Shoshoni

Western Shoshoni has twelve consonants. All of them occur medially between vowels, and all but glottal stop occur word-initially (Crum & Dayley 1993: 233).

p	t	ts	k	kw	ʔ
	s				h
m	n				
		y		w	

There are six short vowels and six long vowels, all of which can appear in word-initial and word-final position, although long vowels at the end of words are rare (230-231).

i, ii	u, uu
e, ee	o, oo
	a, aa
	ai, aai

As we have already glimpsed, Western Shoshoni exhibits what have traditionally been called “final features”. These are a set of effects that one morpheme (prefix, root, or

suffix) can have upon the following morpheme. For Western Shoshoni, these features have been described as *nasalizing*, *preaspirating*, and *geminating* (Crum & Dayley 1993: 235; for discussion of final features in other Numic languages see McLaughlin 1987). Each morpheme is idiosyncratically specified for one of these features, or for no features at all. The effects of these different features can be seen in the table below, which shows various nouns used with the object-incorporating verb *pa'in* ‘have’.

Western Shoshoni final features (Crum & Dayley 1993: 251)

Nasalizing

tsoon	‘beads’	→ tsoompa'in	[çõ: mba ʔi]	‘have beads’
poseken	‘bridge’	→ posekempa'in	[pósiyĩ mbà ʔi]	‘have a bridge’
taman	‘tooth’	→ tamampa'in	[tãmã mbà ʔi]	‘have teeth’

Pre-aspirating

haih	‘uncle (FaBr); crow’	→ haihpa'in	[háí ʰ àʔi]	‘have an uncle or crow’
siippeh	‘urine’	→ siippehpa'in	[sí: pp ʰàʔi]	‘have urine’
to'ih	‘pipe’	→ to'ihpa'in	[tóʔi ʰ àʔi]	‘have a pipe’

Geminating

tua"	‘son’	→ tuappa'in	[tú app àʔi]	‘have a son’
paite"	‘daughter’	→ paiteppa'in	[pé ðipp àʔi]	‘have a daughter’
tepa"	‘pine nuts’	→ tepappa'in	[tí βapp àʔi]	‘have pine nuts’

(Plain)

kahni	‘house’	→ kahnipa'in	[káhni β àʔi]	‘have a house’
tsoo	‘grandparent’	→ tsoopa'in	[çó: β àʔi]	‘have a grandparent’
appe	‘father’	→ appepa'in	[áppi β àʔi]	‘have a father’

When nasalizing morphemes combine with a following stop-initial morpheme like *pa'in*, they produce a nasal consonant that is homorganic in place with the following consonant,

and they turn the voiceless stop into a voiced one, thus /p/ → [b]. Pre-aspirating morphemes turn a stop into a voiceless fricative, thus /p/ → [ɸ]. Geminating morphemes turn a voiceless singleton stop into a geminate, /p/ → [pp]. And plain morphemes, meaning those without any final feature, create an intervocalic environment that, generally throughout Western Shoshoni, turns voiceless stops into voiced fricatives, /p/ → [β].

Note that a Western Shoshoni morpheme cannot end in anything other than a “final feature” or a vowel; there are no morpheme-final consonants in the strict sense. Furthermore, despite their appearance as *n* and *h* in the orthography, nasal and aspiration features actually have very restricted distributions (1993: 235). For example, in nasalizing morphemes, no nasal segment is pronounced in phrase-final position, which includes words pronounced in isolation. Thus, *nemmen* ‘we, our (excl)’ is pronounced [n̥im̥m̥i] (1993: 241), and the examples in the table above are also produced without an overt final nasal. In aspirating morphemes, no aspirated segment is pronounced in phrase-final position either. Furthermore, no nasal or aspirate sound is pronounced before consonants other than oral occlusives and nasals⁷. Thus, there is no surface nasal segment when a possessor like *nean* ‘my’ combines with a root beginning in [w, y, h]: *nea wampu* ‘my trap’, *nea yuhu* ‘my grease, fat’, *nea haih* ‘my uncle (FaBr); my crow’ (250). Although Crum & Dayley (1993) do not state this explicitly, it also appears that no nasal segment occurs before roots beginning with a vowel: *nea appe* ‘my father’, *nea ehe* ‘my

⁷ According to the description in Crum & Dayley (1993: 235), [h] does not occur in these environments; according to the phonetic transcriptions that they give of most examples, however, [h] can occur in these environments.

blanket' (250). However, we do see some effects of nasality and aspiration on surrounding vowels. In nasalizing morphemes, nasalization spreads to the preceding vowel and sometimes to the following vowel, and in pre-aspirating morphemes, final single short vowels are devoiced (240-241).

The point of interest for us is found in the verb paradigm where geminating morphemes, such as *yaa-* 'carry, take-SINGULAR' and its suppletive form *hima-* 'carry, take-PLURAL' trigger gemination when they combine with most suffixes. This is what we expect of a "geminating" root (Crum & Dayley 1993: 253).

yaa- 'carry, take-SINGULAR'

-taippeh	COMPLETIVE	→ yaattaippeh	'taken completely'
-kan	STATIVE	→ yaakkan	'hold
-kin	'here, hither'	→ yaakkin	'bring here'
-kwanto'in	'going to take away'	→ yaakkwanto'in	'going to take away'

hima- 'carry, take-PLURAL'

-taippeh	COMPLETIVE	→ himattaippeh	'taken completely'
-kan	STATIVE	→ himakkan	'hold'
-kin	'here, hither'	→ himakkin	'bring here'
-kwanto'in	'going to take away'	→ himakkwanto'in	'going to take away'

The twist comes with the suffixes *-ten* 'PRESENT PARTICIPLE' and *-to'in* 'FUTURE' which, even when they combine with so-called geminating roots, do not geminate.

yaa- 'carry, take-SINGULAR'

-ten	PRES. PARTICIPLE	→ kai yaaten	'not take'
-to'inna	FUTURE (- <i>nna</i> GENERAL)	→ yaato'inna	'will take'

hima- 'carry, take-PLURAL'

-ten	PRES. PARTICIPLE	→ kai himaten	'not take'
-to'inna	FUTURE (- <i>nna</i> GENERAL)	→ himato'inna	'will take'

There is no segmental reason for the failure to geminate here; other verbal suffixes that are [t]-initial, such as the *-taippeh* ‘COMPLETIVE’, exhibit gemination after these same roots.

3.2 Traditional approach to morphologically-conditioned gemination

Traditional approaches treat gemination in terms of phonological constituents, namely empty timing units such as the X-slot or the mora (e.g. Davis 1994, Hayes 1986a, 1986b, Hyman 1985a, Inkelas & Cho 1993, Schein & Steriade 1986). These units, apart from lacking featural content, have the same status as other segments and so can form part of an underlying representation. By associating an empty unit diacritically with a morpheme’s representation, and then appealing to subsequent auto-segmental spreading, such an approach can account for the behavior of geminating morphemes in Western Shoshoni.

Underlying representation:	/himaX/	‘carry, take-PLURAL’
Word-building:	/himaX-taippeh/	COMPLETIVE
Leftward spreading:	[himattaippeh]	‘taken completely’

The phonologically-oriented approach initially seems appealing in a language like Western Shoshoni, where geminating morphemes co-exist morphemes with other morphemes that appear to be diacritically marked for phonological constituents, such as the [NASAL] feature for the nasalizing morphemes and the [CONTINUANT] feature for the pre-aspirating morphemes.

The problem is in accounting for the behavior of the suffixes *-ten* ‘PRES. PARTICIPLE’ and *-to'in* ‘FUTURE’. What seems to be needed is a mechanism to diacritically mark a morpheme as a “non-spreader” (i.e., morphemes whose segments fail to spread featural material) or a “deleter” (i.e., morphemes which delete an adjoining

segment, such as an X). But traditional phonological theory does not offer any felicitous way of implementing such a mechanism, making its analysis of Western Shoshoni problematic.

3.3 Resizing Theory analysis of Western Shoshoni

The Western Shoshoni pattern can be analyzed straightforwardly in terms of morpheme contact relationships. We will analyze the “geminating” morphemes such as *hima-* as very weak morphemes. Whenever they come into contact with a morpheme like *-taippeh* ‘COMPLETIVE’, the relationship gets realized with upsizing (via gemination) of the strong morpheme.

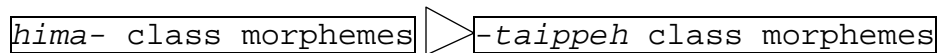

“The boundary between morphemes in the *hima-* class and morphemes in the *-taippeh* class requires a lot of relative strengthening on its left side and/or relative weakening on its right.”

The relationship must be formulated in these general terms because the set of very weak morphemes is not limited to verb roots like *yaa-* and *hima-*, but can also include prefixes and suffixes.

This relationship triggers an upsizing movement on the suffix scale which, as a result, surfaces with a geminate initial consonant.

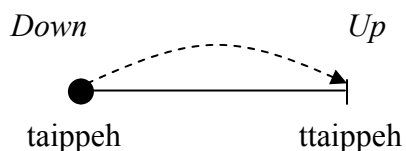

/hima/ + /taippeh/ → himattaippeh ‘taken completely’

This allomorphy scale is obviously simplified. Depending upon the morpheme that precedes it, suffix-initial /t/ can take on several different forms, such as [d], [ð], and [θ] (just as we saw for initial /p/ in *pa'in* ‘have’). For now, however, this simplified scale suffices to illustrate our point.

Some suffixes, namely *-ten* ‘PRES. PARTICIPLE’ and *-to'in* ‘FUTURE’ are not in the *-taippeh* class. Instead, these suffixes are also very weak. That is, they exactly have the same strength status as the very weak roots and therefore, they trigger no surface phonological change. Normally we would not bother to encapsulate such an observation in a strength relationship, but here the failure to produce a change is exactly the point, so we can formalize the relationship as follows.

hima- class morphemes □ Very weak suffixes (*-ten*, *-to'in*)
 “The boundary between morphemes in the *hima-* class and the morphemes *-ten* and *-to'in* does not require strengthening or weakening.”

So when a very weak root such as *hima-* ‘carry, take-PLURAL’ combines with a very weak suffix such as *-ten* ‘PRES. PARTICIPLE’, no contact relationship obtains between them and hence no movement occurs on any allomorphy scale. That is, we get mere concatenation with no gemination: /*hima-ten*/ → [himaten]. The lack of gemination in these morphological environments is thus predicted by the same set of mechanisms that predicts gemination in other environments, namely the presence or absence of a strength relationship.

3.4 Extending the analysis to other morpheme types

The Resizing Theory analysis can be extended to at least one of the other morpheme types in Western Shoshoni, and doing so solves the second part of the puzzle that we faced in the beginning of the section, namely the irregular behavior of *-ten* ‘PRES. PARTICIPLE’ with non-geminating roots such as *etein-* ‘be cold’. The key to extending the analysis involves reanalyzing the so-called pre-aspirating morphemes as *devoicing* morphemes, which, in the terms of the current study, means that they are weak and trigger upsizing on the stronger morpheme via devoicing.

Recall the effects that pre-aspirating and plain morphemes have on a subsequent morpheme such as *pa'in* ‘have’ (Crum & Dayley 1993: 251; repeated from above). In the first case, /p/ simply alternates to the voiceless fricative [ɸ]. In the second, /p/ alternates to the voiced fricative [β].

Pre-aspirating				
haih	‘uncle (FaBr); crow’	→ haihpa'in	[háɪɸàʔi]	‘have an uncle or crow’
siippeh	‘urine’	→ siippehpa'in	[sí:ppiɸàʔi]	‘have urine’
to'ih	‘pipe’	→ to'ihpa'in	[tóʔi ɸàʔi]	‘have a pipe’
(Plain)				
kahni	‘house’	→ kahnipa'in	[káhniβàʔi]	‘have a house’
tsoo	‘grandparent’	→ tsoopa'in	[có:βàʔi]	‘have a grandparent’
appe	‘father’	→ appepa'in	[áppiβàʔi]	‘have a father’

The voicing and fricativization effects triggered by plain morphemes such as *kahni* ‘house’ are general throughout the language. This is demonstrated by the fact that they are also found morpheme-internally where no morpho-phonological conditioning

effects are in force: *tapai* [táβe] ‘sun, day; clock’, *takapoo* [táyaβò:] ‘ball, sphere’. The voiceless stop /t/ exhibits two basic lenited variants. After front vowels, /t/ voices and fricativizes, *saiten* [síði]. After non-front vowels it voices and reduces to flap, *soten* [sóri] ‘that’. (Crum & Dayley 1993: 242).⁸

The term “pre-aspirating” is thus a misnomer (and not just because pre-aspiration, strictly speaking, does not occur in Western Shoshoni; the term probably derives from general Numic features) (see Sapir 1925). Singleton stops become fricatives in *any* intervocalic environment, whether a pre-aspirating morpheme is present or not. What the “pre-aspirating” morphemes actually do, then, is devoice the following consonant. That is, they undo the general process of intervocalic voicing (but notably, not the general process of intervocalic fricativization) in order to produce a voiceless fricative.

This allows us the opportunity to reconceptualize the “pre-aspirating” morphemes. If the voiceless consonants that they produce are longer than their voiced counterparts, then the devoicing effect as an upsizing one, producing e.g. the following size scale for *pa'in* ‘have’.

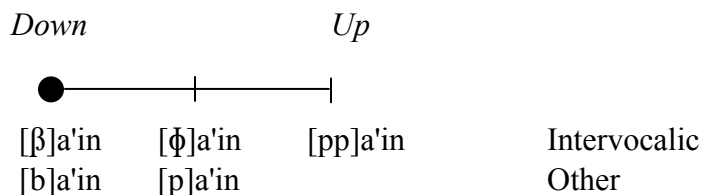

The voiced singleton allomorph [β]a'in is the shortest and therefore occupies the downsizing endpoint of the scale. The voiceless geminate allomorph [pp]a'in is the longest

⁸ When the final vowel is voiceless, voicing and frication (or reduction) are optional: [táβe] ~ [tápe] ‘sun, day; clock’.

and occupies the upsizing endpoint, while the voiceless singleton [p̥]a'in lies in between. (Here I am treating [b] as the variant of [β] that occurs after a nasal consonant, and [p] as the variant of [p̥] that occurs in word-initial position).

Importantly, the starting point for scalar movement in an intervocalic environment is not the underlying form /p/a'in, but rather the voiced and fricativized form [β]a'in. This follows from our definition of a starting point, discussed in the previous chapter.

STARTING POINT for scalar movement: The allomorph which would occur when *no* strength relationship is operative.

In Western Shoshoni, intervocalic voiceless stops become voiced fricatives when no strength relationship is operative, so the starting point on the current scale is [β]a'in, indicated by a black circle.

Thus the “pre-aspirating” morphemes, which we re-analyzed as “devoicing” morphemes, can be further and finally re-analyzed as weak morphemes that trigger upsizing via devoicing when they combine with a regular morpheme of the *-taippeh* class, according to the following contact relationship.

haih- class morphemes < -taippeh class morphemes

“The boundary between morphemes in the *haih-* class and morphemes in the *-taippeh* class requires a relative weakening on its left side and/or a relative strengthening on its right.”

The relationship is realized by upsizing the strong morpheme via devoicing, which is a one-point movement on the allomorphy scale.

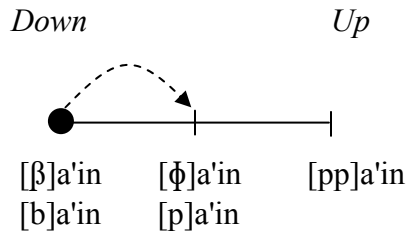

/haih/ ‘uncle’ (weak) + /pa'in/ ‘have’ (-*taippeh* class) → (hai[β]a'in) → hai[ϕ]a'in

This contrasts with the end-point movement on the allomorphy scale that produced gemination: the very weak (“geminating”) roots that we analyzed in the previous section had a very lopsided strength relationship with regular suffixes, which we said needed to be “a lot stronger”.

We are now in a position to analyze the apparent oddities that we observed in the verbal paradigm; these fall out directly from contact relationships that we have already proposed for independent reasons. Recall that in the verbal paradigm, roots such as *etein-* ‘be hot’ as well as *eitse'in-* ‘be cold’ behave like “pre-aspirating” morphemes in most instances, despite the apparent presence of nasality at the end of the root (Crum & Dayley 1993: 252). Only before the suffix *-ten* ‘PRES. PARTICIPLE’ does nasality surface.

etein- ‘be hot’			
-teki	‘start’	etei <u>h</u> teki [ð]	‘start to be hot’
-taippeh	COMPLETIVE	etei <u>h</u> taippeh [ð]	‘completely hot’
-kan	STATIVE	etei <u>h</u> kan [ɣ]	‘be hot’
-kwanto'in	‘going to’	etei <u>h</u> kwanto'in [ɣ]	‘going to be hot, will become hot’
-ten	PRES. PARTICIPLE	etei <u>n</u> ten [nd]	‘being hot, heat’

eitse'in- 'be cold'			
-taippeh	COMPLETIVE	eitse'ih <u>t</u> aippeh [ð]	'completely cold'
-kan	STATIVE	eitse'ih <u>k</u> an [ɣ]	'be cold'
-hinto'in	FUTURE	eitse'ih <u>h</u> into'in	'will be cold'
-kwanto'in	'going to'	eitse'ih <u>k</u> wanto'in [ɣ]	'going to be cold'
-tekito'in	'will start'	eitse'ih <u>t</u> ekito'in [ð]	'will start to be cold'
-ten	PRES. PARTICIPLE	eitse' <u>i</u> nten [nd]	'(being) cold'

In the current analysis, roots like *etein-* 'be hot' have exactly the same strength status as any other "pre-aspirating" morpheme: that is, they are weak roots which trigger upsizing via devoicing with most suffixes that they attach to.

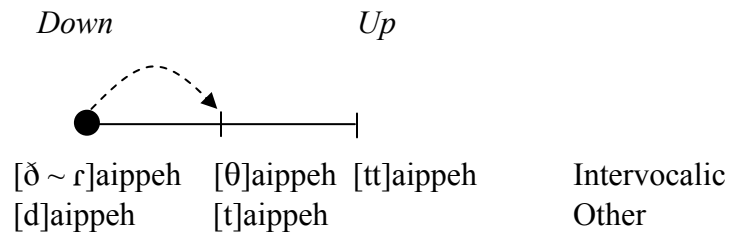

/etei(n)/- 'be hot' (*haih-* class) + /-taippeh/ 'COMPLETIVE' → (etei[ð]aippeh) → etei[θ]aippeh

So far so good. But how do we account for the failure of nasality to appear in the surface form *etei[θ]aippeh* 'completely hot'? In this case, the best argument is that roots like *etein-* actually contain no nasality feature at all. They are spelled with an *n* in the orthography, but the distribution of surface [n], which occurs only before the suffix *-ten* 'PRES. PARTICIPLE' and nowhere else, simply does not support its phonological presence. Thus, in the concatenation of *etein-taippeh*, which should be represented underlyingly as

/etei-taippɛh/, the target consonant /t/ is in intervocalic position, justifying the starting point on the allomorphy scale as [ð ~ r] (i.e., the allomorph that would occur if no strength relationship were operative).

Now when weak roots like *etein-* ‘be hot’ combine with the suffix *-ten* ‘PRESENT PARTICIPLE’, however, we see something different. Recall that we classified this suffix as *very weak* on the basis of its failure to trigger gemination when it combined with *very weak* (“geminating”) roots. By transitivity, this means that *-ten* is also weaker than roots like *etein-* ‘be hot’.

haih- class morphemes ▷ Very weak suffixes (-ten, -to'in)
 “The boundary between morphemes in the *haih-* class and the (“very weak”) morphemes *-ten* and *-to'in* requires strengthening on its left side and/or weakening on its right side.”

This is the first case that we have seen in which a Western Shoshoni root is actually stronger than the suffix. How is this strength relationship manifested? We can argue that it is manifested like every other relationship in the language, namely by upsizing of the strong morpheme. In this case, interestingly, upsizing takes the form of [n]-epenthesis.

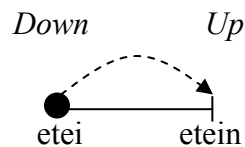

/etei/ (weak) + /ten/ (weaker) → *etei[nd]en* ‘being hot, heat’

The weak morpheme, *-ten*, does not move on the allomorphy scale. It remains in its starting position, indicated by a black circle, although its initial consonant does undergo

phonologically-conditioned alternation to [d], which is the allomorph found in non-intervocalic environments.

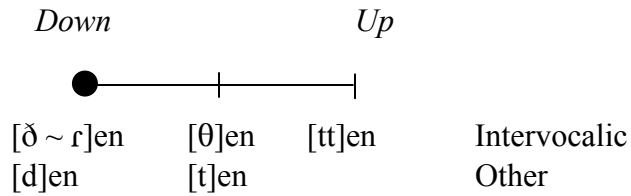

3.5 Alternative analysis using co-phonologies

We began our investigation into Western Shoshoni with the puzzle of “geminating” roots which, with certain suffixes, fail to trigger gemination. I argued that this failure to geminate cannot be accounted for using traditional phonological constituents, even when they are diacritically associated with a particular morpheme. A somewhat different phonological approach, however, could conceivably handle this problem. Within the theory of co-phonologies, for example (e.g. Orgun 1999, Inkelas & Zoll 2005, 2007), it would be possible to state that the insertion of an empty timing unit is part of the co-phonology that applies whenever a root like *hima-* ‘carry’ and a suffix like *-taippeh* ‘COMPLETIVE’ are joined during word-building. Co-phonologies can, by their very nature, be specific to certain combinations of morphemes, so all we need to do is state that this co-phonology does not apply when *hima-* and *-ten* ‘PRES. PARTICIPLE’ are joined.

While this solves the problem of gemination versus non-gemination for roots like *hima-* ‘carry’, it requires a separate analysis for the problem of devoicing versus nasalization that we observed in roots like *etein-* ‘be cold’. Different co-phonologies could of course be posited for this root in combination with different suffixes, but doing

so would lose the generalization that *-ten* ‘PRES. PARTICIPLE’ has a special status with ramifications for more than one kind of root in the verbal paradigm. The analysis in terms of morpheme contact relationships, by contrast, assigns this morpheme a status (“very weak”) that accounts for its behavior with both types of root, and therefore accounts for both of the apparently unrelated oddities of Western Shoshoni at once.

4. Divergent upsizing in Hungarian

Our final example of morphological constraints comes from Hungarian. This case is different from those that we have previously examined because the requirement to upsize is a very general one in the language, imposed by certain segment combinations. Thus although morpheme strength relationships do not themselves trigger surface changes, they crucially determine the way in which upsizing ultimately occurs.

In Hungarian (Vago 1980; Kenesei, Vago, and Fenyvesi 1998; Siptár & Törkenczy 2000) automatic lengthening occurs at the juncture between coronal stops and sibilants, and between coronal stops and glides. Specifically, lengthening at the juncture between [t, d] and [s, z, ʃ] produces a geminate affricate, while lengthening at the juncture between [t, d, n, t^y, d^y, n^y] and [j] produces a geminate palatalized consonant.

Crucially, however, the internal structure of the resulting geminate differs according to the context in which it was created. Across root-suffix boundaries, lengthening targets the coronal stop portion, creating a geminate with a long stop and relatively short sibilant or glide; these cases are transcribed as [t^s:], [t^ʃ:], and so on.

Hungarian root-suffix combinations

(Zsigiri 1994, via Siptár & Törkenczy 2000: 193; except as noted)

Note that some examples show the effects of regressive voice assimilation.

lat-szik	/t-s/ → [t ^s :]	‘seem’	
barát-sag	/t-ʃ/ → [t ^ʃ :]	‘friendship’	
negyed-szer	/d-s/ → [t ^s :]	‘fourthly’	
fárad-sag	/d-ʃ/ → [t ^ʃ :]	‘pains’	
ed-zés	/d-z/ → [d ^z :]	‘training’	
sarjad-z-ás	/d-z/ → [d ^z :]	‘sprout-VBL-NML’	KVF 1998
látja	/t-j/ → [t ^y :]	‘see’ (3sg indic def)	KVF 1998
kenje	/n-j/ → [n ^y :]	‘smear’ (3sg imperative def.)	KVF 1998
bán-ja	/n-j/ → [n ^y :]	‘regret-DEF.3sg’	KVF 1998
bátyja	/t ^y -j/ → [t ^y :]	‘his brother’	KVF 1998
hagyja	/d ^y -j/ → [d ^y :]	‘leave’ (3sg indicative/imperative def.)	KVF 1998
hányja	/n ^y -j/ → [n ^y :]	‘throw’ (3sg indicative/imperative def.)	KVF 1998

That is, in the creation of surface geminates across root-suffix boundaries, it is the final consonant of the root which lengthens, while the initial consonant of the suffix stays the same or even shortens somewhat.

In the same phonological environment, lengthening also occurs across word-word boundaries. Here, however, the internal structure of the resulting geminate is quite different. In these contexts, lengthening targets the sibilant or glide portion, creating a geminate with a relatively short stop closure and a long sibilant or glide; these cases are transcribed as [t^{s̆}s], [t^{ʃ̆}ʃ], and so on.

Hungarian word-word combinations

(Zsigiri 1994, via Siptár & Törkenczy 2000: 193, except as noted)

járat-szám	/t-s/ → [t ^s s]	‘service number’	
virágot szed	/t-s/ → [t ^s s]	‘pick flowers’	
többlet-súly	/t-ʃ/ → [t ^ʃ ʃ]	‘excess weight’	
szeret sétálni	/t-ʃ/ → [t ^ʃ ʃ]	‘be fond of walking’	
köd-szitalás	/d-s/ → [t ^s s]	‘misty drizzle’	
szabad szemmel	/d-s/ → [t ^s s]	‘with unaided eye’	
padsor	/d-ʃ/ → [t ^ʃ ʃ]	‘row of seats’	
szabad sáv	/d-ʃ/ → [t ^ʃ ʃ]	‘unobstructed lane’	
rövid-zárlat	/d-z/ → [d ^z z]	‘short circuit’	
svéd zászló	/d-z/ → [d ^z z]	‘Swedish banner’	
mit jelent	/t-j/ → [t ^y j]	‘what does it mean’ (optional, [t ^y j] ~ [tj])	KVF 1998
van joga	/n-j/ → [n ^y j]	‘he’s got the right (to)’	KVF 1998

In what follows, I give a brief overview of certain aspects of Hungarian phonology before turning to an analysis in terms of Resizing Theory.

4.1 Overview of Hungarian

The consonant inventory of Hungarian includes the following segments, all of which may occur either short or long (Siptár & Törkenczy 2000: 18-19).

p	t	t ^y	k
b	d	d ^y	g
f	s	ʃ	x
v	z	ʒ	
	ts	tʃ	
		dʒ	
m	n	n ^y	
	l		
	r	j	

Geminates can occur in word-medial positions, both underlyingly as in *szappan* ‘soap’ and derived as in *kép-pel* ‘picture-INS’ (Kenesei, Vago, and Fenyvesi 1998: 396).

Geminates can also occur in word-final positions, again both underlyingly as in *ott* ‘there’ and derived as in *olvad-t* ‘melt-PAST.3SG’, where the final cluster undergoes regressive voicing assimilation to produce [tt] (Kenesei, Vago, and Fenyvesi 1998: 389). Siptár & Törkenczy state that most geminate consonants are derived, and that underlying geminates are relatively frequent and restricted to “marginal” lexical classes such as onomatopoeia, interjections, proper names, and loanwords (2000: 19).

The vowels of Hungarian are /ɔ, a:, ε, e:, i, i:, o, o:, ø, ø:, u, u:, y, y:/.

Hungarian words are generally formed by the agglutination of suffixes, each of which has a single morphological function, onto a stem. Derivational suffixes get added first, then inflectional suffixes. The concomitant morpho-phonological processes that occur are for most stems rather general, and include voicing assimilation, nasal place assimilation, and low vowel lengthening (27). There are, however, some minor stem classes which do exhibit alternations during word-building; these are closed classes.

The gemination processes described above are part of a larger system in Hungarian whereby various segment combinations produce geminate affricates. For example, stop plus affricate combinations that occur across morpheme boundaries also produce geminate affricates. The output in these cases seems to be restricted to affricate geminates with a long stop and relatively short sibilant.

<i>sötét cella</i> 'dark cell'	/t-ts/ → [ts:]	Siptár & Törkenczy 2000: 190
<i>öt csomag</i> 'five packets'	/t-tʃ/ → [tʃ:]	Siptár & Törkenczy 2000: 190

Furthermore, affricate plus fricative combinations also produce geminate affricates. Here, however, the output is restricted to geminates with a relatively short stop closure and relatively long sibilant portion.

<i>piac szélén</i> 'at the side of the market'	/ts-s/ → [t̪ˢs]	Siptár & Törkenczy 2000: 193
<i>kalács-sütés</i> 'baking of a milk loaf'	/tʃ-f/ → [t̪ʃ̪]	Siptár & Törkenczy 2000: 193

In both of the above cases, the geminate output appears to be tied directly to the amount of featural material that is present underlyingly, and not to a morphological effect. That is, when more features for coronal stop closure are present underlyingly, as in the /t-ts/ and /t-tʃ/ cases, the output exhibits a long coronal stop closure. But when more features for a sibiliant are present underlyingly, as in the /ts-s/ and /tʃ-f/ cases, the output exhibits a long sibiliant portion. It is only when a “tie” occurs -- that is, when the amount of underlying stop closure features roughly equals the amount of underlying sibilant features, as in the /t-s/ and /t-f/ cases -- that we see the effects of different morphological constructions.

4.2 Traditional analysis of Hungarian

A traditional analysis of this phenomenon uses timing units, phonological constituents that are well-known for their role in a variety of processes (see Siptár &

Törkenczy 2000: 188-194). In essence, this analysis proposes that a re-association of features to timing units occurs at any boundary where a coronal non-continuant (represented here by a capital T) and a sibilant or palatal glide (here S) come together. The reassociation can take different forms: leftward spreading in some contexts to produce geminates with lengthened closures, such as [tː], and rightward spreading in other contexts to produce geminates with lengthened sibilants or glides, such as [tːs̄].

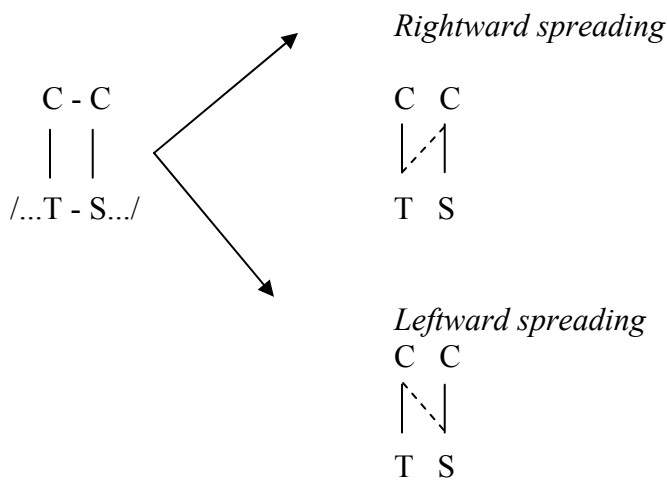

Now, the first part of this analysis, namely the triggering environment /...T-S.../, must somehow be integrated into any analysis of Hungarian, because the lengthening process is restricted to these segmental contexts. But the second part of the analysis, namely the directionality of subsequent spreading between features and timing units, is problematic because there is no way to predict which direction spreading will take. Sometimes spreading goes leftward, and sometimes it goes rightward.

Zsigri (1994), cited in Siptár & Törkenczy (2000: 193-194) proposes that rightward spreading is a lexical operation which, by definition, occurs in root-suffix constructions while leftward spreading is post-lexical operation which occurs in word-

word constructions. An appeal to the difference between lexical versus post-lexical processes seems to be broadly correct, and my own analysis of Hungarian also draws on this distinction, albeit in a different way. Still, the proposal is not restrictive enough because it allows for the possibility of the mirror-image pattern. That is, we should expect to see a language that is like Hungarian except that sibilants and glides lengthen in the lexical stratum while stops lengthen in the post-lexical stratum.

Alternatively, a traditional analysis could associate the phonological processes of leftward or rightward spreading with particular morphemes via diacritics. Suppose that we associate all root morphemes with rightward spreading, such that e.g. the presence of the root *lat* triggers spreading of the features for [t], *lat-szik*, /t-s/ → [t^s:] ‘seem’. This accounts for the root-suffix examples. In the word-word examples, however, two roots are present. Regardless of which root takes control of the process, then, we expect rightward spreading to occur, but this expectation is not met. There appears to be no proper way to define the conditions under which leftward spreading should occur, and indeed no way to meaningfully talk about feature spreading at all. Hungarian thus presents another case of phonological under-determinism.

4.3 Resizing Theory analysis of Hungarian

In the analysis that I propose for Hungarian, the stronger morpheme is always the one that exhibits upsizing, and therefore the one that contributes the most length to the internal structure of the affricate. But how do we determine which morpheme is stronger? Unlike many of the examples from other languages that we have looked at, upsizing in Hungarian is not triggered by the presence of any particular morpheme or set of

morphemes. Rather, it is triggered by the presence of specific segments in the input, namely T and S. This suggests that the “stronger” morpheme is determined by very general principles of contact, such as the following.

Roots▷**Affixes**

“The boundary between a root and an affix requires a relative strengthening on its left side and/or a relative weakening on its right side.”

When a root and a suffix come together, as in */lat▷szik/* ‘seem’, a general strength relationship between them is operative. This relationship is realized by upsizing of the strong morpheme, triggering an upsizing movement on its allomorphy scale.

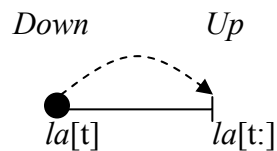

The surface result is a geminate affricate (or palatalized consonant) whose internal structure consists of a long coronal stop followed by a short sibilant (or glide), [t^s].

When a word and a word come together, as in */járat szám/* ‘room number’, there is no suffix present and therefore the strength relationship **Roots**▷**Affixes** is not operative. In general, when no specific relationship is operative, we might expect one of two possible outcomes: either nothing happens, or a default strength relationship takes over. I argue that in Hungarian, the following default relationship is operative:

Leftmost◁**Rightmost**

“The boundary between a lefthand element and a following righthand element requires a relative weakening on its left side and/or a relative strengthening on its right side.”

For a construction such as */járat◁szám/* ‘room number’, this relationship is realized by upsizing the stronger element, triggering movement on its allomorphy scale.

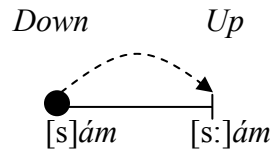

The surface result is a geminate affricate (or palatalized consonant) whose internal structure consists of a short coronal stop followed by a long sibilant (or glide), [t^s].

The appeal of this analysis is that surface lengthening is tied directly to the stronger morpheme. That is, in any given environment, we can predict the internal structure of the surface geminate simply by knowing which morpheme is stronger. We do not need to make reference to directionality of feature spreading, which proved problematic, and we make a more restricted set of predictions than that of Zsigri (1994), who proposed different lexical and post-lexical processes.

4.4 General contact relationships: Roots and rightmost elements

My analysis of divergent gemination in Hungarian relies on two contact relationships, Roots \triangleright Affixes and Leftmost \triangleleft Rightmost. These relationships are not, however, the actual trigger for change; rather, the trigger is defined in strictly segment-specific terms, requiring the presence of a coronal followed by a sibilant or glide. I would like to argue, then, that these relationships act as defaults. That is, while they are not generally operative in Hungarian (we do not see, for example, upsizing occur at *every* root-suffix boundary in Hungarian), they can kick into gear precisely when the phonology fails to completely determine an output. The status of these relationships as defaults is supported by typological patterns in which roots (on the one hand) and rightmost elements (on the other) exhibit a special status.

Cross-linguistically, the overall strength of roots is well-attested for the upsizing and downsizing alternations under consideration here. In the 100+ languages included in the database for the current study, for example, there are several languages in which roots as a class are stronger than affixes as a class: Acooli (Crazzolara 1938), Ibibio (Urua 2000, Harris & Urua 2001), Hup and Yuhup (Lopes & Parker 1999), Maithili (Jha 2001), Meithei (Chelliah 1997), and Mokilese (Harrison & Albert 1976). In each of these languages, a root-affix construction triggers upsizing of the root, regardless of which root or which suffix is involved. In Meithei, for example, gemination occurs consistently at every root-suffix boundary, cf. [tʃéll-i] ‘runs’, [tʃǎŋŋí] ‘enters’, [ləyy-i] ‘is’, [tʰǎmm-e] ‘keeps’, [tʰǎmm-u], ‘keep!’, [yeŋŋ-u] ‘look!’ (Chelliah 1997: 67). But the reverse pattern is not attested: there are no languages in which affixes as a class are stronger than roots as a class. Now, in the vast majority of examples in the database, individual morphemes are idiosyncratically strong, and such morphemes can be either roots or suffixes. But when idiosyncratic differences do not occur, the overall strength of roots emerges, as in Acooli et al., and also (as I am arguing) in Hungarian.

The strength of roots is also attested for other diverse phonological processes, suggesting that root strength has the status of a general principle. For example, vowel and consonant harmony patterns exhibit an overwhelming preference for spreading outward from the root onto affixes, rather than the reverse (Hansson 2001, Hyman to appear). Similarly, vowel elision patterns exhibit a preference for preserving vowels in roots, as opposed to those in affixes (except when the affix consists of a single V; Casali 1997).

As traditionally conceived, “strength” in these cases does not dictate an upsizing alternation in the root (or downsizing in the affix), as it does in the current study, but

rather the preferential preservation of underlying phonological material in the root, an idea formalized as positional faithfulness in Beckman (1997). However, we can readily submit the vowel elision cases (and potentially the harmony ones) to an analysis in which strength does dictate such changes. If Roots \triangleright Affixes, for example, this strength relationship can be realized in a root-suffix construction by downsizing the suffix via deletion of its initial vowel, as in Chichewa /mwana-uyɔ/ \rightarrow [mwanayɔ] ‘that child’ (Casali 1997: 521, from Mtenje 1992). The same analysis then holds for prefix-root constructions in Chichewa, which also exhibit concomitant upsizing of the root, /mù-à̀nà/ \rightarrow [mà:nà] ‘fish trap’ (Casali 1997: 522, from Watkins 1937). It is also conceivable to analyze harmony in terms of morpheme strength relationships, although doing so would require extending the notion of “upsizing” to include the expansion of a domain of features from one morpheme to another. The broader point is that roots, as a class of morphemes, clearly have a special status that is attested in diverse processes, and we may refer to this status as strength.

The notion of rightmost elements being stronger than leftmost elements is also supported by cross-linguistic patterns of upsizing and downsizing, as well as other phonological and morphological processes. A straightforward way of evaluating this claim is to examine constructions in which two morphemes have equal strength, as in reduplication, where both elements arguably have the same morphemic source (Inkelas & Zoll 2005). In my database, when reduplication constructions trigger upsizing, it virtually always occurs on the rightmost element. This generalization holds for upsizing via gemination, as in the Hausa plural construction, *bugà:* \rightarrow *bu-bbùga:* ‘beat’ (Newman 2000: 424).

It also holds for upsizing via devoicing, as in Nishnaabemwin *baashkzaw* → *baa-paashkzaw* ‘shoot at AN (plural subject)’ (Valentine 2001: 429).

Other phonological processes show a similar effect. In vowel and consonant harmonies, spreading can originate from suffixes (rightmost elements) when the harmony is not root-controlled, but never from prefixes (leftmost elements) (Hansson 2001, Hyman to appear). In consonant deletion, the rightmost consonant in an intervocalic cluster is preferentially preserved (Wilson 2001). In consonant assimilation, the features of the rightmost consonant are typically preserved while those of the leftmost consonant are overwritten (Steriade 1997). Finally, in vowel elision, vowels in the rightmost member of compounds are preferentially preserved over those in the leftmost member (Casali 1997), a generalization that is particularly interesting because it parallels the Hungarian case so closely. For example, in Emai compound constructions, vowel hiatus gets resolved by deleting the first vowel and preserving the second (examples from Schaefer 1987 via Casali 1997: 513):

/ɔ-da-ɛɲɔ̃/ → [ɔdɛɲɔ̃] ‘drunkard’
PREFIX-drink-wine

/u-kpe-akɔ̃/ → [ukpakɔ̃] ‘chewstick’
PREFIX-wash-teeth

The rightmost element in these compounds does not have a privileged morphological status over the leftmost member, since both members are lexical words. But the rightmost

element does have a privileged status (or strength) that derives from its position, and this strength accounts for the preservation of its vowel⁹.

Morphological evidence also supports a general strength relationship Leftmost < Rightmost. This evidence comes from cross-linguistic patterns of noun-verb compounding (H. Anderson 1997) and noun incorporation (Caballero et al. submitted). In both types of construction, we may consider the verb to be the head. This is because the noun functions as its object, as in the English noun-verb compound *dishwasher* or the incorporated form *babysit*. In a given language, when the ordering of noun and verb constituents within a word diverges from the ordering attested within sentences, the permitted order is always noun-verb. A simple example comes from English, whose sentential word order demands VO (*wash dishes*), but whose morphology permits OV in compounds (*dishwasher*). Significantly, no language uses a VO template in the morphology; for both compounds and incorporation, if VO order occurs in morphological words, it also occurs in sentences. These patterns arguably point to a cross-linguistic preference for placing the head of a morphological word in the rightmost position. This observation is not new; Edwin Williams' (1981) formalized it as "Righthand Head Rule": "[i]n morphology, we define the head of a morphologically complex word to be the right-hand member of that word" (248).

In sum, there seems to be substantial cross-linguistic evidence to support the default strength relationships of Roots > Affixes and Leftmost < Rightmost. These relationships do the work that the segmental phonology of Hungarian cannot do; namely they determine how upsizing occurs at the juncture of a coronal stop and sibilant or glide.

⁹ This is my interpretation. Casali (1997) makes a somewhat different argument, namely that this effect is due to preferential preservation of word-initial segments.

5. Conclusion

The purpose of this chapter was to see how far we can push a phonology-free analysis of length alternations, where “phonology-free” means that we do not refer to features such as [NASAL] or timing units such as X. From one perspective, the answer is that features and segments are intimately bound up with length alternations, and we cannot get very far without them at all. I referred to the features [-continuant] and [NASAL] in my analysis of Pări, for example, and I referred to coronal and sibilant segments in my analysis of Hungarian. From another perspective, however, this experiment in phonology-free thinking has allowed us to offer fairly straightforward analyses of what were otherwise hairy problems. Removing nasality, even if only partly, from the analysis of Pări resolved a conundrum about divergent surface forms of upsizing. Removing timing units from the analysis of Western Shoshoni solved the problem of so-called exceptional affixes. And removing spreading directionality from the analysis of Hungarian provided a straightforward set of predictions for which type of morpheme should upsize, and when. In each of these cases, the extra work was done by contact relationships, and I hope to have shown that, despite their close linkage with phonological constraints, they are indeed capable of exerting an independent force of their own.

Chapter 4: Bringing null allomorphs back into the fold

1. Introduction

The current study is an attempt to analyze certain morpho-phonological alternations based on their relative size in the length dimension. Scales impose an ordering on surface variants (or *allomorphs*) according to their size; a logical endpoint for such a scale is, of course, the null allomorph (\emptyset), which has no surface manifestation and thus possesses no length at all. We have seen some examples of the null allomorph in previous chapters: in Turkish and Pări, a single segment /k/ alternates with its absence [\emptyset], and we referred to this change as a “deletion.” When a larger chunk of segmental material alternates with [\emptyset], however, it is more common to refer to this situation as “morphological blocking,” a well-known phenomenon in which the presence of one morpheme completely suppresses the presence of another. Because Resizing Theory squarely encompasses the possibility of null allomorphs, it also enters squarely into the empirical realm of morphological blocking -- yet in doing so, it makes a very different set of predictions than previous theories have. The purpose of the current chapter is to offer support for these predictions.

A straightforward example of morphological blocking comes from Hupa (Golla 1970, 1996a). In this language, the prefix morpheme *win-* indicates perfective aspect, and the prefix morpheme *e:-* indicates a first person singular subject. Despite their phonological and semantic compatibility, these two morphemes do not co-occur on a

Hupa word. Instead, the first singular *e:-* “blocks” the perfective *win-*, which surfaces as [Ø].

ni₆-win₃-e:₂-ʌonʔ → ne:₁ʌoʔn ‘I have been good’(Golla 1996a: 370)

The all-or-nothing quality of such alternations has been a built-in feature of almost every previous theory of morphological blocking (cf. Aronoff 1976, Anderson 1986, Iverson & Wheeler 1988, Rainer 1988, Andrews 1990, Stump 1991, 2001, Halle & Marantz 1993, Inkelas 1993, Carmack 1997, Noyer 1998, Stewart 2001, and Kiparsky 1982, 2005).

I argue against the all-or-nothing view. A major prediction of Resizing Theory is that null allomorphs have no special status, and no special conditions are required to trigger them. Rather, null allomorphs are simply one point on a size scale, just like any other point. The most interesting consequence of this approach is that it predicts *partial* morpheme blocking. That is, just as the presence of one morpheme can trigger the null allomorph of another morpheme (total morpheme blocking), the presence of one morpheme can also trigger a “medium-sized” allomorph of another morpheme (partial morpheme blocking).

We see this prediction borne out in Hupa, where the perfective prefix *win-* can actually surface along a cline of possibilities, [Ø], [n], [wi], or [win], depending upon the presence of other morphemes on the word.

<i>Perfective allomorph</i>	<i>Example</i>		
∅	ne:moʔn	‘I have been good’	(1996a: 370)
ŋ	yehky’iŋyohɯ	‘(water) surged in’	(1996a: 370)
wi	yehwidqot’	‘it wiggled in’	(1970: 65)
wiŋ	yehtʃ’ iwɪŋyay	‘he went in’	

In other words, just as the first singular *e:-* triggers a null perfective allomorph, the third person subject *ky’i-* triggers a small-sized allomorph *ŋ-*, and the classifier *di-* triggers a medium-sized allomorph *wi-*. This is precisely the kind of effect we expect to see if [∅] occupies a point on a size scale, and exists along a length-based cline with other points.

In the sections that follow, I explore this prediction in more detail. First I briefly review previous approaches to morphological blocking, which differ in significantly from each other but share an all-or-nothing approach (§2). Then I explore two case studies that bear out the major prediction of the current theory. The first, from Hupa, offers an example of how segmental morphemes can get “chipped away” along a cline leading to ∅ as the result of contact relationships of various degrees (§2). The second case study, from Kanuri, takes this idea in a new direction and offers an example of how tone and segment combinations can become “unpacked,” again along a cline leading ∅, and again as the result of contact relationships (§4). Next, I draw on shorter language examples to show how the same analytical apparatus that handles blocking also handles the behavior of so-called truncating morphemes in Koasati and West Greenlandic (§5). The final section concludes (§6).

2. Previous theoretical treatments of blocking

The term “blocking”, originally from Aronoff (1976), has been used with two different meanings. It may refer to the non-existence of otherwise well-formed words, as in English where **oxes*, **gooses*, **tooths* are all blocked. Or it may refer to the suppression of individual morphemes within a word. So in our Hupa example, the perfective *win-* is blocked by the first singular *e:-* in *ne:moʔn* ‘I have been good’, **niwine:moʔn*. Similarly, in a widely cited Georgian example, the first singular *v-* is blocked by the second singular *g-* in *g-k’lav* ‘I kill you (sg)’, **g-v-k’lav*, **v-g-k’lav* (Anderson 1986: 6).

Several researchers have argued that the origin of both types of blocking is the same, and I think it is reasonable to say that this has been a consequence of the analytical framework that these researchers have adopted. Anderson (1986) offers a good example. He argues that both types of blocking result from *disjunctive ordering*, by which the application of an earlier, specific rule blocks the application of later rules. For word blocking, the existence of the word *oxen*, which already contains the meaning of both OX and PLURAL, blocks the later application of regular plural formation. For morpheme blocking, the application of the *g*-affixation rule in Georgian takes precedence, and therefore blocks the later, disjunctive application of the *v*-affixation rule (as Anderson points out, this is an example of how disjunctive ordering can implement position class morphology). Certainly the appeal of the idea, also developed as the “Elsewhere Principle” in Anderson (1969), Kiparsky (1973) and much subsequent work, is its capacity to deal with such a range of phenomena; Anderson even speculates that both word and morpheme blocking are “morphology-specific realizations of a more basic,

general cognitive condition giving priority to specific processes over more general ones which they include” (1986: 5).

Disjunctive ordering represents an all-or-nothing approach: if a rule introducing affixation is skipped because a prior rule has already applied, it is skipped for good. There is no provision for the partial application of a rule; as Anderson writes, “the mutual exclusion of phonological and morphological rules...is essentially absolute” (1986: 5, footnote 5). Interestingly, however, Anderson does note that the blocking of syntactic paraphrases has a very different status than the blocking of morphological rules. While paraphrases such as **the day after today* are disfavored due to the existence of lexical items such as *tomorrow* (Kiparsky 1982), they are not absolutely disallowed, and are regularly used in dictionary definitions, for example. There is no real provision in the theory, however, for this non-absolute status.

Inkelas (1993) introduces and analyzes a different type of morphological blocking. In the Papuan language Nimboran, the presence of one morpheme can block the presence of another morpheme that shares the same position class; this is the same type of blocking that occurs in Hupa and Georgian, and can be handled with disjunctive ordering. The twist with Nimboran is that the presence of one morpheme can also block the presence of *multiple* adjacent morphemes, even those that do not share a position class. For example, in Nimboran, the dual subject morpheme occurs in position 2, and is blocked by the durative. But the masculine object morpheme occurs in position 3, and is also blocked by the durative (1993: 586-587). Inkelas offers a lexicon-based analysis in which “massively blocking” morphemes such as the durative have subcategorization frames which specify that they attach at level i , but produce a constituent of level

$i+2$, $i+3$, etc. The result is the suppression of morphemes that might have otherwise occurred at e.g. level $i+1$: “[i]t is obligatory in this model for attachment at all intervening levels (‘positions’) to be bled and thus for morphological blocking to take place” (1993: 601). At the level of individual morphemes, then, Inkelas’s proposal also represents an all-or-nothing approach because a given morpheme surfaces either in its full form or as \emptyset . At a broader level, however, it is worth noting that her proposal does encompass a certain notion of length or size because one, two, or more morphemes can be blocked at a time. This is, of course, a different notion of length than I have taken up in the current study, which focuses on the length of one morpheme at a time.

Carmack (1997) offers a very different analysis of blocking, in which an entire affix *frame* gets evaluated for the specificity with which it matches a morpho-syntactic target. The frame includes all relevant prefix and suffix positions at once; thus, affixes are not added in a piecemeal fashion to a word, but are evaluated as part of a bigger package. While this proposal represents a departure from previous ways of thinking, it retains the essential idea of disjunctive ordering: the affix frame with the most specificity blocks all other affix frames that could potentially express the target meaning. Blocking is total, and intermediate forms have no status in the grammar.

Rainer (1988) is perhaps the only author who hints at a position contra the all-or-nothing approach, although his proposal is speculative and not formalized. Rainer focuses on word blocking, for which he distinguishes between token-blocking, in which a regular rule fails to apply to a few lexically-listed items, as in English **oxes*, and type-blocking, in which one rule applies regularly in certain conditions, but an alternative rule applies regularly in the elsewhere case, as in Dutch plural formation. For token-blocking to occur,

several conditions are required: Synonymy (the morphologically complex word means same thing as lexically listed word), Productivity (it should be possible for a blocked word to be formed by a productive rule), and Frequency (the blocking force is a function of the frequency of the blocking word; frequent words are less exposed to the danger of being superseded by morphologically complex synonyms). Thus, in Rainer's terms, "the blocking force" is "the result of the antagonism between the pressure exerted by a potential regular word and the resistance offered by the corresponding blocking word, whereby pressure is a function of productivity and resistance a function of frequency" (1988: 164). Rainer does not develop these notions further, so I unfortunately cannot consider them in more detail except to say that the formulation of blocking in terms of "pressure" and "resistance" certainly suggests the possibility of an intermediate outcome, of the kind that I will argue does exist.

In sum, while several different approaches to morphological blocking have been proposed, they all treat the null allomorph as if it were a special case that warrants a particular analysis all of its own. In the sections that follow, I will show that the null allomorph can and should be analyzed just like any other type of downsizing, and that treating it as a special case actually obscures its relationship with other allomorphs. It should be borne in mind, however, that the previous analyses do cover areas of empirical importance, such as whole-word blocking and "massive" morpheme blocking, points to which I will return at the end of the chapter.

3. Scales in Hupa

In Resizing Theory, the null allomorph is not special. This is implicit in the construction of size scales in which the null allomorph occupies a point on the scale just like meatier allomorphs do, as in the following scale for the Hupa perfective *win-*.

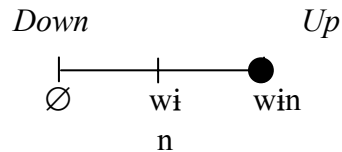

The prediction made by such scale is that the same type of morpheme contact relationships which trigger null allomorphs can also trigger intermediate allomorphs, such as [wi] and [n] (the fact that these two allomorphs share a single point on the scale will be discussed below). In other words, while the process of downsizing a morpheme can have its logical endpoint in [∅], it is in no way restricted to this. Resizing Theory thus integrates the null allomorph with other allomorphs, while also offering an explanation for the partial reduction of [win] into forms like [wi] and [n], which would otherwise need to be handled by ad-hoc segmental deletion rules.

<i>Perfective allomorph</i>	<i>Example</i>		
∅	ne:moʔn	‘I have been good’	(1996a: 370)
ŋ	yehky’iŋyohɯ	‘(water) surged in’	(1996a: 370)
wi	yehwidqot’	‘it wiggled in’	(1970: 65)
wiŋ	yehtʃ’ iwiyay	‘he went in’	

In the sections that follow, which are based on Pycha (to appear a), I demonstrate how this size scale accounts for this pattern of partial reduction, bearing out the prediction that the null allomorph has a length-based status just like any other allomorph.

3.1 Overview of Hupa

Hupa is an Athabaskan language of Northern California. It has a large consonant inventory [t, t’, k, k’, k^y, k^y’, q, q’, b, d, g, g^y, ts, ts’, tʃ’, tʃ, tʃ’, tʃ^w, tʃ^w’, dz, dʒ, s, ʃ, x, x^w, m, n, ŋ, l, l̥, h, w, ɯ, y, ʔ] and a relatively small vowel inventory [a, ε, i, o, ʌ, a:, ε:, o:] (Golla 1996b: vii-ix).

Hupa verbs are built almost entirely by prefixation. Prefixes are commonly analyzed as belonging to particular positions in the a template, with position 1 being the prefix closest to the root, position 2 being the next farthest out, and so on. For Hupa, Golla (1970, 1996a) has proposed ten positions.

6. Positions in the Hupa verb

10 Adverb theme	9 Iterative	8 Plural	7 Object 3 rd subj	6 Theme	5 Adverb	4 Distrib	3 Mode	2 1 st , 2 nd subj	1 Classif	Root
-----------------------	----------------	-------------	-------------------------------------	------------	-------------	--------------	-----------	--	--------------	------

In what follows, I will use the template to orient the reader toward the complex organization of the Hupa verb, and I will include subscripted position numbers when I discuss Hupa morphemes: e.g., the classifier l_1 - (position 1), the first person singular subject \mathfrak{M}_2 - (position 2), the perfective win_3 - (position 3), and so on.

The literature on Athabaskan languages is vast; for examples of work related to the concerns of current study, see Kari (1989), McDonough (1999), Rice (2000).

3.2 Null allomorphy (total blocking)

In our basic blocking example, *ne:moʔn* ‘I have been good’, the morphemes of interest are the first person singular subject and the perfective. The first person morpheme usually occurs in prefix position 2 (in very limited circumstances, not relevant to the discussion here, it can occur in a different position) and its allomorph is usually [ʌ]. Just when the verb is in the perfective aspect, however, its allomorph is [e:]. This is shown in the examples below, where the allomorphs for the first singular are underlined¹⁰.

Imperfective:	<i>ni<u>ʌ</u>ahʌ</i> ‘I arrive’	(1970: 59)
Customary:	<i>neʔi<u>ʌ</u>ahʌ</i> ‘I always arrive’	(1970: 59)
Optative:	<i>ni<u>ʌ</u>aʔ</i> ‘let me arrive’	(1970: 59)
Perfective:	<i>ne:<u>e:</u>ya</i> ‘I arrived’	(1970: 59)

On the basis of its wider distribution, it seems fair to suppose that /ʌ/ is the underlying form for the first person singular subject.

¹⁰ According to Golla (1996a: 370), this alternation to $e_{:2}$ - is triggered only in non-neuter verb forms. Other verb forms with perfective mode retain the \mathfrak{M}_2 -allomorph, *nin_3- \mathfrak{M}_2- l_1-da:ʌ* → *nimdahʌ* ‘I arrived running’ (1996a: 370), *s_3- \mathfrak{M}_2-te:n* → *simitij* ‘I am lying down’.

The perfective morpheme usually occurs in prefix position 3. Its basic forms are [s], [nin], and [win]. In any given perfective verb, the selection of [s], [nin], and [win] appears to be a lexical one, governed by the verb root. Even though they all mark perfective aspect, however, it is difficult to say whether these forms are properly allomorphs of one another. Each form is subject to its own morphological and phonological processes. For example, [nin] reduces to [n] when it is preceded by a long vowel, but this environment has no comparable effect on [s] or [win] (1996a: 370). Also, [win] reduces to [n] when it is preceded by a third person subject, but this environment has no comparable effect on [s] or [nin] (1996a: 370). On the basis of these and similar observations (see Golla 1970: 61ff, 1996a: 370ff), it seems that we must treat these three forms as separate morphemes that all happen to mark perfective aspect, which is the stance I will take here.

The perfective morpheme that we will principally be concerned with in the sections that follow is *win*₃-.

yehtʃ' **iwɪŋ**yay 'he went in'

When no stronger morphemes are present, this morpheme surfaces as [win]. In the above example, this form undergoes a phonological process of regressive place assimilation.

We may therefore consider /win/ to be the underlying form.

When stronger morphemes are present, however, *win*₃- undergoes changes. The first person singular subject is one such morpheme. It cannot co-occur with the perfective *win*₃-, and causes it to delete entirely.

ni ₆ - win ₃ - ʌ ₂ - ʌonʔ	→ ni-∅-e:-ʌonʔ	→ ne:ʌoʔn 'I have been good' (1996a: 370)
ya:10- win ₃ -ʌ ₂ -ɬ ₁ -wa:ɬʔ	→ ya:-∅-e:-ɬ-wa:ɬʔ	→ ya:yɬwaʔɬʔ 'I threw it up into the air' (1996a: 370)

Note that there are two things going on in the examples above. One change is the complete deletion of perfective *win₃*-. A second change is the allomorphy of the first person, which changes from underlying /ʌ/ to [e:]. Recall that this process is conditioned by the presence of any perfective, not just *win₃*-. This is shown in the following example, which contains the perfective *s₃*-.

na:10- s₃- ʌ₂- yaʔ → na:se:yaʔ 'I have gone about' (1996a: 370)

There does not appear to be a phonological process in Hupa which could account for the restriction on the co-occurrence of first singular subject and *win₃*-. Surface sequences of [ne:], such as that which would potentially be created by the concatenation of *win₃*- and *e:2-*, are generally permitted in the language: *ne:sijyaŋ* 'you grew up' (1996a: 370). Even if such sequences were not permitted, deletion of the entire perfective morpheme would be a radically non-local and unexpected phonological repair. It thus appears that Hupa possesses a purely morphological co-occurrence restriction, which the grammar resolves by totally blocking the appearance of *win₃*-, even when it continues to be semantically present.

3.3 Partial allomorphy (partial blocking)

Our next example includes another set of Hupa morphemes, called the classifiers.

These occupy position 1, just before the verb root, and have the forms [l], [ʔ], and [di].

Examples of each are underlined below.

diw <u>l</u> toʔn	‘you jumped off’ (1970: 71)
ʔine:di <u>ʔ</u> iŋ	‘we look at each other’ (1996a: 372)
no:xoneh <u>ʔ</u> tiŋ	‘I have put him down’ (1996a: 370)
ʔi <u>ʔ</u> ʔatʃ	‘you sneeze’ (1970: 61)
ʔina:ʔas <u>di</u> qeʔ	‘he got up’ (1970: 63)
se: <u>di</u> yaŋ	‘we are old’ (196: 370)

It is extremely difficult to pin down the morphemic status of classifiers, and this is one of the classic problems of Athabaskan linguistics. Classifiers can form part of a discontinuous set of pieces that, together, make up what might be referred to as a single morpheme. For example, the set of discontinuous pieces which, in Hupa, translates as ‘look at’ contains the adverbial theme *ne:-* in position 6, the classifier *ʔ-* in position 1, and the root *ʔe:n* (1996a: 372). If the resulting “morpheme” is [ne:₆...ʔ₁-ʔe:n], then the best we can do might be to say that *ʔ-* is a “sub-morpheme”. I cannot resolve this issue here, except to say that classifiers trigger and undergo some of the same processes that independent morphemes do. On that criterion, I will treat them as individual morphemes.

The pattern that we are interested in concerns the classifiers and the perfective *win*₃-. When these occur together on the same word, *win*₃- reduces to *wi*₃-.¹¹

yeh₁₀-win₃-di₁-qut' → yehwidqot' 'it wiggled in' (Golla 1970: 65)

The restriction on classifiers and the perfective *win*₃- is almost certainly a morphological one, and not the result of phonological restrictions. The segment sequences that could potentially be created by concatenation of the relevant morphemes include [nl], [nɬ], and [ndi]. It is true that underlying sequences of /nl/ regularly undergo deletion of the nasal to become /l/, as in *di*₅- *wi*₃- *n*₂- *l*₁- *ton*?- *i* → *diwiltoʔn* 'you jumped off' (1970: 71), and this phonological process could account for those cases in which the perfective *win*₃- and the classifier *l*₁- adjoin. But there is no similar phonological process which could account for the reduction that takes place when the classifiers are *di*₁- or *ʔ*₁-. For example, sequences of [nd] that arise by morpheme concatenation are regularly permitted to surface.

no:-nin-de:ɬ' → nondeʔɬ' 'they (animals) went no farther' (1996a: 370)

Sequences of [nɬ] that occur underlyingly are also permitted to surface, such as that found in the *nʔi*- morpheme which marks the reciprocal. (The status of [nɬ] sequences that arise by concatenation is not clear to me).

¹¹ According to Golla (1970: 61-62), the perfective *nin*₃- also reduces in this situation, to *ni*₃-, but I have not been able to locate an example of this.

yaʔnɪnɪlʔiŋ ‘they look at each other’ (1996a: 369)

Hupa therefore arguably exhibits a purely morphological restriction on the occurrence of the classifiers and the perfective *win*₃-. Interestingly, however, the grammar of Hupa resolves this situation by only *partially* blocking the appearance of *win*₃-. One of its segments (namely *n*) is suppressed, but the others are permitted to surface in their usual position. Analyzing the pattern in this way – as partial blocking – allows us to view it as crucially related to the previous pattern we examined – that is, total blocking and the null allomorph.

Partial blocking is not an isolated phenomenon in Hupa. There are at least two more examples of it, both of which involve subject morphemes. The first and second person subject morphemes, *ɬ*-, *n*-, *di*-, and *oh*-, occupy prefix position 2. The presence of any of them triggers a reduction of the perfective morphemes, such that perfective *nin*₃- surfaces as *ni*₃-, and perfective *win*₃- surfaces as *wi*₃¹². I have only been able to locate an example of the former.

*nin*₃- ɬ₂- l₁-da:ɬ → niɬdahɬ ‘I arrived running’ (1996a: 370)

Given the diversity of shapes exhibited by the first and second person subjects – two are C, one is CV, and one is VC – it seems highly unlikely that this restriction has its origin in the phonology. It appears to be purely morphological.

¹² Interestingly, the presence of a first or second person subject morpheme triggers not reduction, but augmentation, of the perfective *s*₃-. *s*₃- ɬ₂-te:n → siɬtiŋ ‘I am lying down’ (1996a: 370). This is another piece of evidence to support the idea that the three perfectives are separate morphemes in Hupa.

There is another example of partial blocking. The presence of a third person subject *ky'i-*, which occurs in prefix position 7, also triggers the reduction of perfective *win₃₋* (although not, apparently, of perfective *nin₃₋* or *s₃₋*). In this case, *win₃₋* surfaces as a single nasal consonant *n* (which becomes [ŋ] by regular regressive assimilation in the example below).

yih₁₀₋ ky'i₇₋ win₃₋ yo:ɬ → yehky'inyohɬ '(water) surged in' (1996a: 370)

This particular restriction is unique because it requires that the third person subject *ky'i₇₋* and the perfective *win₃₋* be adjacent to one another, with no morphemes from other position classes intervening. Despite this locality requirement, the restriction appears to be morphological and not phonological. For example, sequences of [iwi], such as that which would occur if the third person *ky'i₇₋* and perfective *win₃₋* adjoined, are regularly permitted to surface in Hupa, cf. *di₅₋wi₃₋n₂₋l₁₋tonʔ-i* → *diwiltoʔn* 'you jumped off' (1970: 71), *naʔmiwiɬditehʔ* 'he was taking me along back' (1996a: 372).

I claim that partial blocking lies on a continuum with total blocking in Hupa. In every case, the effect is caused by the presence of an antagonistic morpheme. In every case, a number of segments delete, ranging from some segments to all segments. The goal of Resizing Theory is to capture this continuum.

3.4 Resizing Theory analysis

We can formalize a contact relationship between Hupa first person singular subject and perfective *win*₃- morphemes as follows.

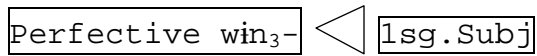

“The boundary between Perfective *win*₃- and the first singular subject requires a lot of relative weakening on its left side and/or a relative strengthening on its right.”

This relationship gets manifested with the shortening of the perfective. The strength differential between first singular subject and the perfective *win*₃- is so great that it pushes the perfective all the way the shortest end-point of the size scale – that is, all the way to the shortest allomorph, \emptyset .

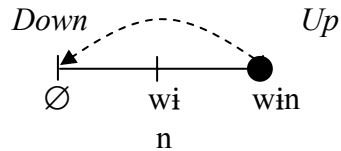

ni_6 - win_3 - \mathfrak{M}_2 - $\mathfrak{M}on?$ → ni_6 - \emptyset_3 - $e:2$ - $\mathfrak{M}on?$ → $ne:\mathfrak{M}o?n$ ‘I have been good’

This is what we have referred to as total blocking, analyzed as one form of morphologically-induced shortening.

When no contact relationship obtains between the perfective *win*₃- and another morpheme, there is no action on the scale. In other words, we do not predict that the morpheme should become shorter (or longer), and the morpheme simply surfaces as *win*₃- (which, in the example below, becomes *wiŋ* by regular regressive assimilation).

yeh_{10} - $tʃi_8$ - win_3 - $ya-i$ → yeh_{10} - $tʃi_8$ - $wiŋyay$ ‘he went in’

The point of real interest lies in the in-between cases. When a different degree of contact relationship obtains between the perfective *win*₃₋ and another morpheme, we of course see a different degree of movement on the scale. Recall that when a classifier such as *di*₁₋ and the perfective *win*₃₋ occur in the same Hupa word, *win*₃₋ reduces to *wi*₃₋:

*yeh*₁₀-*win*₃₋-*di*₁₋-*qut*' → *yehwidqot*' 'it wiggled in'. Under my analysis, this is the result of the following contact relationship.

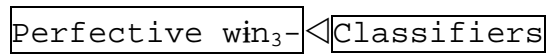

“The boundary between the perfective *win*₃₋ and Classifier morphemes requires a relative weakening on its left side and/or a relative strengthening on its right.”

To manifest the contact relationship, the weaker morpheme downsizes. The strength differential between the classifiers and the perfective *win*₃₋ is not great, and pushes the latter just one point shorter on the size scale, where the partial allomorphs *win* and *n* are located.

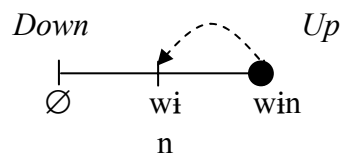

How does the grammar adjudicate between *win* and *n*, which occupy the same point on the scale? I hypothesize that the choice between them is determined by locality. In the example at hand, classifiers always lie to the right of the perfective *win*₃₋ in the linear order of the word: [... *win*₃₋...*ɬ*/*di*₁₋...] If the presence of a classifier morpheme triggers the shortening of another morpheme, we might expect the shortening to affect

precisely that phonological material which lies *closest* to the trigger, explaining why the *n* of the underlying *win* deletes and the resulting allomorph is [wi].

The other patterns of partial blocking in Hupa give us some reason to think that this hypothesis might be correct. Recall that the presence of a first or second person subject morpheme also triggers a downsizing of the perfective morphemes, such that *nin*₃- surfaces as *ni*₃-, and *win*₃- surfaces as *wi*₃, e.g. *nin*₃-*m*₂-*l*₁-*da*:*m* → *ni**m**dah**m* ‘I arrived running’. Like the classifiers, the first and second person subject morphemes lie to the right of the perfectives in linear order of the word: [... *win*/*nin*₃-...*m*/*n*/*di*/*oh*₂-...]. Again, downsizing affects the phonological material that lies closest to the trigger, deleting *n* and producing a surface form *ni* or *wi*.

Just when a triggering morpheme lies to the *left* of the perfective, however, downsizing deletes material from the other side of *win*₃-. Recall that the presence of the third person morpheme *ky*'*i*₇- downsizes the perfective to *n*: *yih*₁₀-*ky*'*i*₇-*win*₃-*yo*:*m* → *yehky*'*ijyoh**m* ‘(water) surged in’. This can be captured with the following contact relationship.

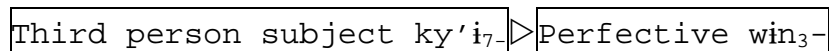

“The boundary between the third person subject *ky*'*i*₇- and the perfective *win*₃- requires a relative strengthening on its left side and/or a relative weakening on its right.”

This contact relationship is identical to the one that holds between classifiers and the perfective. Therefore, the movement along the size scale is the same.

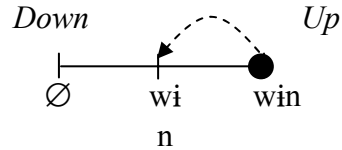

However, the third person $ky'i_7$ lies to the left of the perfectives in the linear order of the word: [... $ky'i_7$... win_3]. If downsizing affects that phonological material which lies *closest* to the trigger, then downsizing should target the segments w and i , leaving [n] as the chosen surface allomorph.

3.5 Other size scales in Hupa

We have already seen that the first person singular subject in Hupa also undergoes allomorphy, but we have not yet offered an analysis of this fact. Recall that in most verb forms (that is, with the imperfect, customary, and optative modes) the surface allomorph for the first person subject is m_2 -. Just when the mode marker is perfective in non-neuter verbs, however, the surface allomorph is $e:2$ -.

If we follow our procedure of arranging allomorphs on a scale according to their size, the $e:2$ - allomorph would lie at the upsizing end because it consists of a long vowel. The m_2 - allomorph would lie at the downsizing end because it consists of a singleton consonant. This gives us the following scale. As before, a black circle indicates the starting point, which is that allomorph which occurs when no contact relationships are operative (and happens to be the same as the underlying form).

Scale for Hupa first person subject

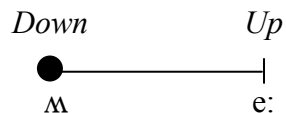

Interestingly, the scalar analysis of the first person allows us to see that contact relationships can be simultaneously manifested in more than one way. Recall that we formalized the relationship between the first person subject and perfective *win*₃- as follows.

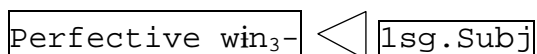

“The boundary between Perfective *win*₃- and the first singular subject requires a lot of relative weakening on its left side and/or a relative strengthening on its right.”

We have already seen that this relationship is manifested by the weak morpheme becoming shorter, reducing from *win* to \emptyset . At the same time, however, it is manifested in additional way. The strong morpheme gets longer, lengthening to *e*:

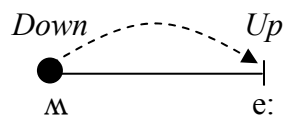

7. ni_6 - win_3 - Λ_2 - $\Lambda on?$ \rightarrow ni_6 - \emptyset_3 - $e:2$ - $\Lambda on?$ \rightarrow $ne:\Lambda o?n$ ‘I have been good’(1996a: 370)

Actually, an important detail is missing from the morpheme contact relationship above. The allomorph $e:2$ - is actually conditioned not just by the perfective *win*₃-, but by any perfective morpheme including *nin*₃- and *s*₃- (cf. $na:10$ - s_3 - Λ_2 - $ya?$ \rightarrow $na:se:ya?$ ‘I have

gone about' [1996a: 370]). A more accurate contact relationship which captures all of the facts would therefore be something like the following.



This three-way scale predicts that the perfectives *nin*₃₋ and *s*₃₋ should both be stronger than the perfective *win*₃₋. It is not possible to test this prediction directly in Hupa, because multiple perfective morphemes do not occur on verbs. For future research, it may be possible to test the prediction indirectly by examining independent processes such as stress assignment.

The table below provides an interim summary of the analysis of the Hupa perfective that we have developed thus far.

8. Full range of relationships for Hupa perfective *win*₃₋

<i>Underlying form</i>	<i>Contact relationship</i>	<i>Selected allomorph</i>	<i>Surface form</i>	<i>Blocking</i>
yeh ₁₀ -tʃ' i ₈ -win ₃ -ya-i	(none)	win	yehtʃ' iwiŋyay	None
yeh ₁₀ -win ₃ -di ₁ -qut'	win ₃ < di ₁	wi	'he went in' yehwidqot'	Partial
yeh ₁₀ -ky' i ₇ - win ₃ - yo:ɬ	ky' i ₇ > win ₃	n	'it wiggled in' yehky' iŋyohɬ	Partial
ni ₆ -win ₃ -ɬ ₂ -ɬonʔ	win ₃ < ɬ ₂	∅	'(water) surged in' ne:ɬoʔn 'I have been good'	Total

3.6 Transitivity of contact relationships

Given the three contact relationships that I have proposed for Hupa, all of which contain the perfective, we might expect that they interact with one another, via transitivity, to produce further contact relationships. Specifically, because the 1sg.Subj is

much stronger than the perfective *win*₃₋, while the classifier *di*₁₋ is somewhat stronger, we might expect that the 1sg.Subj is also stronger than the classifier *di*₁₋. This prediction is borne out to a degree. Recall from a previous example that classifiers normally appear in prefix position 1.

<i>di</i> <u><i>wi</i></u> <i>ltoʔn</i>	‘you jumped off’ (1970: 71)
<i>ʔine:di</i> <u><i>ʔi</i></u> <i>ʔiŋ</i>	‘we look at each other’ (1996a: 372)
<i>no:xoneh</i> <u><i>ʔi</i></u> <i>ŋ</i>	‘I have put him down’ (1996a: 370)
<i>ʔi</i> <u><i>ʔi</i></u> <i>ʔatʃ</i>	‘you sneeze’ (1970: 61)
<i>ʔina:ʔas</i> <u><i>di</i></u> <i>qeʔ</i>	‘he got up’ (1970: 63)
<i>se:di<i>yan</i></i>	‘we are old’ (196: 370)

On words with a first person subject morpheme, however, the classifier *l*₁₋ and the classifier *ʔ*₁₋ fail to appear.

<i>wi</i> ₃₋ <i>ʔ</i> ₂₋ <i>l</i> ₁₋ <i>da:ʔ</i>	→ <i>wi</i> <i>ʔ</i> <i>da</i> <i>hʔ</i>	‘I run along’ (1996a: 369)
<i>no:10-</i> <i>xo</i> ₇₋ <i>ʔ</i> ₂₋ <i>ʔ</i> ₁₋ <i>ti</i> <i>ʔ</i>	→ <i>no:xo</i> <i>ʔ</i> <i>ti</i> <i>ʔ</i>	‘I put him down’ (1996a: 369)
<i>∅</i> ₃₋ <i>ʔ</i> ₂₋ <i>ʔ</i> ₁₋ <i>ʔatʃ</i>	→ <i>ʔi</i> <i>ʔ</i> <i>ʔatʃ</i>	‘I sneeze’ (1970: 61)
<i>na</i> ₁₀₋ <i>∅</i> ₃₋ <i>ʔ</i> ₂₋ <i>ʔ</i> ₁₋ <i>ʔatʃ</i>	→ <i>na</i> <i>ʔ</i> <i>ʔatʃ</i>	‘I sneeze again’ (1970: 61)

This pattern could be analyzed as a direct consequence of the fact that the first person subject is stronger than the classifiers *ʔ*₁₋ and *l*₁₋, as predicted by transitivity between our previously proposed relationships. The classifiers presumably have a size scale that contains just two points; in order to manifest the contact relationship between the first person subject and the classifiers, the classifier gets shorter, surfacing as *∅*.

Size scale for Hupa classifier t_1 -

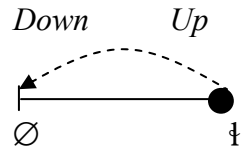

The size scale for classifier l_1 - would be similarly structured.

The pattern of classifiers surfacing as \emptyset does not apply to the classifier di_1 -, however, suggesting the need for more investigation into its behavior. Still, there exists encouraging evidence that the predictions made by transitivity are indeed borne out in Hupa.

3.7 Interim summary

The purpose of the preceding sections was to demonstrate that partial blocking -- that is, the triggering of a partial allomorph by certain morphological conditions -- exists, as predicted by Resizing Theory. Partial blocking places total blocking -- that is, the triggering of a null allomorph -- into the context of a family of morpho-phonological alternations, and shows that the null allomorph is not a special allomorph, but merely a completely downsized one.

4. Kanuri

Kanuri (Lukas 1937, Hutchison 1981, Cyffer 1998) is a language that exhibits several different examples of total morpheme blocking. As I will argue in the sections that follow, which are based loosely on Pycha (to appear b) it also exhibits partial morpheme blocking. Like Hupa, then, full-fledged allomorphs alternate with partial ones.

Unlike Hupa, the full-fledged allomorph consists not of a string of segments, but of a complex of a segment plus tone. The partial allomorph consists of the tone alone.

The specific morpheme that we will be concerned with is the Auxiliary, which is required in the formation of Class 2 verbs in Kanuri. The claim will be that the Auxiliary has a full allomorph which consists of a low tone, L, and a segmental nasal, [N]. In the form below, both the tone and the segment surface, as shown in bold. (Examples and page numbers from Hutchison 1981 unless otherwise noted).

tùsə̀**n**ómin ‘you rest’ (JH 116)

But the presence of certain morphemes, such as a first person object, triggers downsizing of the Auxiliary. The downsizing is partial, such that the L surfaces (in bold below), but the segmental nasal does not.

lèfà**s**ómin ‘you greet me’ (JH 135)

These facts can be handled by a size scale in which the complex of tone-plus-segment is considered the longest allomorph, the tone alone is considered a partial allomorph, and \emptyset is the null allomorph.

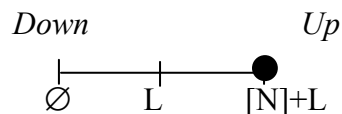

This particular notion of “size” is different from the one that I have used in the rest of the current study, where I refer to the overall length or duration of an allomorph in the construction of scales. Because tones occur simultaneously with segments, and not in a linear sequence with them, the addition of a tone does not contribute to the overall length

or duration of an allomorph in the same way that the addition of a segment does. The size scale above, then, requires expanding the notion of length to a more general metric which refers to the presence (versus the absence) of phonological material in general. I present the case study of Kanuri, then, both to show that such an expansion is possible, and to demonstrate an additional example of partial blocking, a phenomenon that has not been previously discussed in the literature, but which Resizing Theory predicts should exist.

The focus in the following sections will be on establishing the relevant empirical statements for Kanuri: first, that the Auxiliary morpheme consists of a segment+tone complex; and second, that the Auxiliary has a tone-only allomorph which occurs under certain morphological conditions. I then offer a brief analysis in terms of Resizing Theory.

4.1 Segmental correlates of the Auxiliary morpheme

The verbs of Kanuri fall into one of two classes. Class 1 verbs consist straightforwardly of root plus affixes, while Class 2 verb forms additionally require an Auxiliary verb. The latter class “is highly productive and all verbs introduced through innovation or borrowing belong to class 2” (Cyffer 1998: 34).

The basic diagnostic for the presence of the Auxiliary is the presence of a nasal segment, [N], which we can see most clearly by comparing the construction of Class 1 and Class 2 verbs. In the first and second persons, Class 1 verbs are constructed according to the template: Root-Subject-TAM, as shown below for the imperfect paradigm (third person verb forms are constructed differently and will not be discussed here).

Class 1 imperfect verbs

Root 'ask'	Subject	Imperfect TAM		
kór	-k	-ìn	→ kórəkìn	'I ask' (JH 115)
kór	-m	-ìn	→ kórəmìn	'you ask' (JH 115)
kór	-y	-ìn	→ kóriyèn	'we ask' (JH 115)
kór	-w	-ì	→ kórùwì	'you (pl) ask' (JH 115)

Class 2 verbs have a similar template, but differ in that the Auxiliary comes between the verb root and the following suffixes: Root-Auxiliary-Subject-TAM. In the following forms, then, we see the presence of an additional nasal segment that was not present in the comparable Class 1 verbs.

Class 2 imperfect verbs

Root 'rest'	Aux	Subject	Imperfect TAM		
tùs	-n	-k	-ìn	→ tùsəngîn	'I rest' (JH 116)
tùs	-n	-m	-ìn	→ tùsənómìn	'you rest' (JH 116)
tùs	-n	-y	-ìn	→ tùsənyêñ	'we rest' (JH 116)
tùs	-n	-w	-ìn	→ tùsənúwì	'you (pl) rest' (JH 116)

The absence versus presence of a nasal segment can also be seen by comparing Class 1 and Class 2 verbs in the perfect paradigm.

Class 1 perfect verbs

Root 'eat'	Subject	Perfect TAM		
bù	-k	-nà	→ búkónà	'I have eaten' (JH 120)
bù	-m	-nà	→ búmmà	'you have eaten' (JH 120)
bù	-y	-nà	→ búiyénà	'we have eaten' (JH 120)
bù	-w	-à	→ búwà	'you (pl) have eaten' (JH 120)

Class 2 perfect verbs

Root	Aux	Subject	Perfect
------	-----	---------	---------

'look for'			TAM		
má	-n	-k	-nà	→	mángónà 'I have looked for (sth)' (JH 121)
má	-n	-m	-nà	→	mánómmà 'you have looked for (sth)' (JH 121)
má	-n	-y	-nà	→	mányénà 'we have looked for (sth)' (JH 121)
má	-n	w	-à	→	mánúwà 'you (pl) have looked for (sth)' (JH 121)

4.2 Tonal correlates of the Auxiliary morpheme

The Auxiliary also contributes a low tone, L, to the verb. To see this, it is necessary to introduce some background about tones in Kanuri verbs, some of which I draw from Trommer (2005). We will first focus on the verbs which lack an Auxiliary, namely the Class 1 verbs, so that we can establish the basic pattern. We will then turn to verbs which possess an Auxiliary, namely the Class 2 verbs, to see what it is they contribute to the basic pattern.

On the Class 1 verb, there are two basic sources for tones. The first source is the verb root, which may be lexically specified as H or L. The second source are the Tense-Aspect Markers, which are often the final suffix in the word. Crucially, the TAM suffixes contribute two tones. The first tone has a fixed association to the TAM suffix itself; the second tone is floating and associates leftward. For a basic Class 1 verb, then, there are three tones present underlyingly, one contributed by the root and two contributed by the TAM suffix. On a verb form with three syllables, each of these tones is realized in a concatenative fashion. This is shown below for the H-tone root *nót* 'pick up' and the L-tone root *kàr* 'carve' in combination with the perfect TAM *-nà*, which contributes an H and an L. The resulting forms are HHL and LHL, respectively.

	Root	Subject	Perfect TAM		
H root	nót	-m	-nà	→ nótómmà	‘you have picked up’ (NC 71)
	nót	-w	-à	→ nótúwà	‘you (pl) have picked up’ (NC 71)
Tones	H		H L	H H L	
L root	kàr	-m	-nà	→ kàrómmà	‘you have carved’ (NC 71)
	kàr	-w	-à	→ kàrúwà	‘you (pl) have carved’ (NC 71)
Tones	L		H L	L H L	

Notice that the above forms each have only two vowels underlyingly. The vowel for the extra, third syllable gets contributed by a general process of epenthesis which inserts either a high vowel (if [w] or [y] is adjacent) or schwa between prohibited sequences of consonants. This third syllable allows all three of the underlying tones to be realized. When the segmental requirements for epenthesis are not met, the verb form has only two syllables, and one of the three tones must delete. The data that I have examined from Hutchison (1982) suggest that it is the tone of the root which deletes: thus in the form /bù-k-ìn/ → [búkìn] ‘I eat’, the tonal change is /LHL/ → [HL] (JH 115).

Not all TAM suffixes contribute a fixed set of tones like the perfect does. The imperfect TAM *-in*, for example, contributes one polar tone plus one L tone. When attached to a H root, then, the imperfect TAM contributes L and L. When attached to an L root, on the other hand, the imperfect TAM contributes H and L. The basic pattern of tone realization is, however, the same as before: on a verb form with three syllables, each of the three underlying tones is realized in a concatenative fashion. This can be seen below, where the polar tones are underlined.

	Root	Subject	Imperfect TAM		
H root	nót	-k	-ìn	→ nótàkin	‘I pick up’ (NC 71)
	nót	-m	-ìn	→ nótəmìn	‘you pick up’ (NC 71)
	nót	-y	-ìn	→ nótiyèn	‘we pick up’ (NC 71)
	nót	-w	-ì	→ nótùwì	‘you (pl) pick up’ (NC 71)
Tones	H		<u>L</u> L	H <u>L</u> L	
L root	kàr	-k	-ìn	→ kàrəkìn	‘I carve’ (NC 71)
	kàr	-m	-ìn	→ kàrəmìn	‘you carve’ (NC 71)
	kàr	-y	-ìn	→ kàriyèn	‘we carve’ (NC 71)
	kàr	-w	-ì	→ kàrúwì	‘you (pl) carve’ (NC 71)
Tones	L		<u>H</u> L	L <u>H</u> L	

The crucial point for us is as follows. In certain cases, the segmental environment triggers not one, but two epenthetic vowels. The result is a four-syllable verb form. The mismatch between the number of syllables (four) and the number of available tones (three) must be resolved somehow. This mismatch is resolved by leftward spreading from the TAM tones (see Trommer for a similar proposal). This is demonstrated in the perfect TAM forms below, where bolded forms indicate new tone values created by leftward spreading.

	Root	Subject	Perfect TAM		
L roots	kàr	-k	-nà	→ kàr ə kónà	‘I have carved’ (NC 71)
	kàr	-y	-nà	→ kàr í yénà	‘we have carved’ (NC 71)
	làd	-k	-nà	→ làd ə kónà	‘I have sold (sth)’ (JH 121)
	làd	-y	-nà	→ làd í yénà	‘we have sold (sth)’ (JH 121)
Tones	L		H L	L H H L	

The bolded forms are always H, which means that they must have originated from the TAM tones to the right. They could not possibly have originated from the root tone, which is L.

We are now ready to introduce the Auxiliary into the picture, and to see the evidence that the Auxiliary contributes an L tone of its own. We just saw that when epenthesis creates four-syllable forms of Class 1 verbs, leftward spreading places a tonal value on the extra syllable. When epenthesis creates four-syllable forms of Class 2 verbs, however, this does not happen. Instead, the extra syllable is always associated to a L tone. The only possible source for this L tone is the extra morpheme that is present in Class 2 verbs, namely the Auxiliary. This can be seen in the imperfect TAM forms below, where the tones contributed by the Auxiliary are in bold, and polar tones are underlined.

	Root	Aux	Subject	Imperfect TAM		
L root	tùs	-n	-m	-in	→	tùsə̀nómìn ‘you rest’ (JH 116)
	tùs	-n	-w	-in	→	tùsə̀núwì ‘you (pl) rest’ (JH 116)
Tones	L	L		<u>H</u> L		L L <u>H</u> L

In fact, then, verb forms in Class 2 have four underlying tones, unlike verb forms in Class 1 which have only three. The extra syllable created by epenthesis allows this fourth tone, always an L, to surface. The same pattern holds when, for independent reasons, the final H and L sequence forms a contour tone on the final syllable of the word.

	Root	Aux	Subject	Imperfect TAM		
	tùs	-n	-y	-in	→	tùsə̀nyə̀n ‘we rest’ (JH 116)
Tones	L	L		<u>H</u> L		L L <u>HL</u>

The above forms therefore demonstrate the largest allomorph of the Auxiliary, where ‘largest’ includes both a segment component, [N], as well as a tonal component, L. When only three syllables occur on a Class 2 verb, the L associated with the Auxiliary does not surface: *lènámìn* ‘you go’, *lèníwì* ‘you (pl) go’ (JH 116). The tone pattern on these verb forms is the result of just three tones, one from the root (here L) and two from the TAM suffix (here HL).

4.3 Partial blocking in Kanuri

Armed with the basic facts above, we are now in a position to see the phenomenon of partial blocking in Kanuri. The largest allomorph, [N]+L, is reduced to a partial allomorph, consisting of an L tone only.

First and second person object affixes block the segmental expression of the Auxiliary. That is, when such an affix is present, [N] does not surface, shown by the gray shading over [N] in the table below. Crucially, however, the L tone associated with the Auxiliary *does* surface, shown in bold. (The second person object affix *-nz* contains a nasal segment which, according to the discussion in Hutchison 1982, is distinct from the Auxiliary. In order to avoid confusion, I have shown only first person object forms here).

	Root	Aux	Object	Subject	Imperfect TAM		
L root	lèf	-n	-s	-m	-ìn	→	lèfàsómìn 'you greet me' (JH 135)
	lèf	-n	-sa	-m	-ìn	→	lèfàsámìn 'you greet us' (JH 135)
	lèf	-n	-s	-w	-ì	→	lèfàsúwì 'you (pl) greet me' (JH 135)
	lèf	-n	-sa	-w	-ì	→	lèfàsáwì 'you (pl) greet us' (JH 135)
Tones	L	L			<u>H</u> L		L L <u>H</u> L

This is partial blocking: the presence of the first person object morphemes blocks part of the Auxiliary morpheme, but not all of it. This is a morphological effect, and not a local effect of [sn] or [ns] segment combinations. We know this because in general, Kanuri repairs such clusters with either schwa epenthesis or post-nasal voicing.

General segmental processes in Kanuri (Cyffer 1998)

s + n → sən

n + s → nz

The partial blocking pattern is easiest to see in four-syllable forms, like those above, but it also occurs when, for independent reasons, the final H and L sequence forms a contour tone on the final syllable of the word.

	Root	Aux	Object	Subject	Imperfect TAM		
L root	lèf	-n	-s	-s	-ìn	→	lèfàshîn 's/he greets me' (JH 135)
	lèf	-n	-sa	-s	-ì	→	lèfàsâi 's/he greets us' (JH 135)
	lèf	-n	-s	-(s) a	-ì	→	lèfàsâi 'they greet me' (JH 135)
	lèf	-n	-sa	-sa	-ì	→	lèfàsâi 'they greet us' (JH 135)
Tones	L	L			<u>H</u> L		L L <u>H</u> L

Note that the examples above exhibit an additional instance of blocking, which is total.

The presence of a first or second person object affix blocks a third person subject, shaded

in gray. (The exception seems to be the [a] portion of the third plural subject marker in ‘they greet me’).

To be sure that the above examples represent partial blocking, we must be certain that there the L tone on the second syllable comes from the Auxiliary, and not from an alternative source. In particular, we must be certain that the L tone does not get contributed by the newly-introduced object affixes *-s* and *-sa*. We can verify this by turning to the Class 1 verbs, where these same affixes occur without the Auxiliary (although note that they are prefixed, and not suffixed, to the root, unlike the other examples we have seen thus far). The tones on Class 1 verbs show no evidence of an L contributed by object affixes; instead, these affixes either contribute a H or receive a tone value via leftward spreading from the polar H.

	Object	Root	Subject	Imperfect TAM		
L root	s-	tà	-m	-in	→	sátámìn ‘you grab me’ (JH Appendix)
	sa-	tà	-m	-in	→	sátámìn ‘you grab us’ (JH Appendix)
Tones		L		<u>H</u> L		H <u>H</u> L

4.4 Total blocking in Kanuri

In addition to partial blocking, there is some evidence for total blocking of the Auxiliary in Kanuri. Establishing that total blocking actually occurs, however, requires a more thorough understanding of the conditions under which contour tones are created, which I have been unable to glean from available sources. The following short discussion is therefore somewhat speculative.

When a first or second person object affix partially blocks the Auxiliary, the L tone of the Auxiliary can still surface. This typically happens when the verb form has

four syllables, it can also happen when the verb form has three syllables, one of which hosts a contour tone. In the examples above, a contour was created on the final syllable. In the example below, however, a contour is created on the initial root syllable.

	Root	Aux	Object	Subject	Imperfect TAM		
	bák	-n	-s	-m	-in	→	bâksə̀mìn 'you beat me' (JH Appendix)
Tones	H	L			<u>L</u> L		HL L L

The fact that the contour gets created on the initial syllable shows that contours can occur on syllables which are closed by an obstruent. More importantly, it also seems to suggest that the contour is created *just in order* to retain the L contributed by the Auxiliary.

If this is actually the case, then the absence of a contour in comparable forms could be meaningful. In the following form, the Auxiliary is blocked by a third person subject morpheme (recall that first and second subjects do not block the Auxiliary, although first and second objects do). Despite the presence of the same syllable type (CVk), however, no contour tone appears on the root.

	Root	Aux	Object	Subject	Imperfect TAM		
	bák	-n	-	-s	-in	→	bákcìn he/she beats' (H 116)
Tones	H	L			<u>L</u> L		H L

Here the L tone contributed by the does not surface at all, even though we know from the previous example that a tonal contour could be created on *bak-*, which would preserve the L. The third person subject morpheme thus appears to totally block the Auxiliary, reducing it all the way to the null allomorph.

4.5 Analysis of Kanuri

The Resizing Theory analysis of Kanuri is simple. It consists of two contact relationships.

Auxiliary ◁ Third person subject

“The boundary between the Auxiliary and the third person subject requires a lot of relative weakening on its left side and/or relative strengthening on its right side.”

Auxiliary ◁ First, second person object

“The boundary between the Auxiliary and the first or second person object requires relative weakening on its left side and/or relative strengthening on its right side.”

The first contact relationship suffices to trigger an end-point movement on the size scale, and the Auxiliary surfaces as a truly null allomorph.

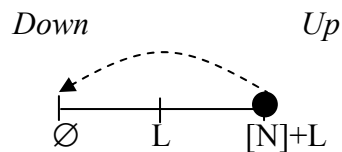

The second contact relationship triggers a one-point movement on the scale, and the Auxiliary surfaces as an L tone, with no accompanying segmental material.

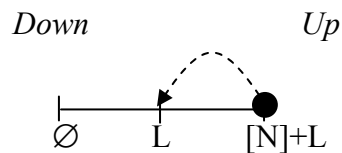

4.6 Interim summary

The idea that tones and segments can diverge from one another is not new, and is well-attested in phonological processes such as segment deletion (references). Part of the reason that Kanuri is of interest is, then, because it shows that tones and segments can also diverge from one another for purely morphological reasons. Furthermore, it also

shows that tone+segment combinations can behave in the same way as segment strings do in e.g. Hupa; that is, they can undergo either a full or partial reduction, just as predicted by Resizing Theory.

5. Partial blocking in Koasati and West Greenlandic

The goal of the preceding discussion has been to place the null allomorph within the context of partial allomorphs, and to show how Resizing Theory predicts the existence of both. Hupa and (to some degree) Kanuri were suitable case studies to demonstrate this point because, in these languages, total morpheme blocking exists side-by-side with partial morpheme blocking, so we see a clear relationship between the two. But of course, Resizing Theory certainly doesn't require that a null allomorph be present. Rather, it predicts that partial allomorphs, of the Hupa [wi] and [n] type, can be triggered by certain morphological conditions, even in the absence of null allomorphs. Another way of putting this is to say that the Resizing Theory gives us a straightforward way of analyzing apparently random segment deletions that occur for morphological reasons.

Koasati (Kimball 1991) presents just such a case of apparently random behavior. In this language, all verbs that end in the classifying suffix *-li* will lose that suffix before one of the following suffixes:

-t connective
-toho- realis
-toha- emphatic realis
-tik but
-V'hco habitual
-V'hci progressive
and all inflectional suffixes unique to class 3Cii

An example demonstrating the partially reduced verb root is below (Kimball 1991: 47-50).

okohó:mi s-yomáhli-toho-k → okohó:mi syomáhtohok
 whiskey INSTR-go.about(PL)-REALIS-IVPAST
 ‘They carried whiskey with them.’

A small set of verbal suffixes also exhibit downsizing effects in these same morphological environments. These suffixes are: *-si/-osi* ‘diminutive/intensive’, *-má:mi* ‘dubitative’, *-á:ho:si* ‘very’, and *-fíhna* ‘too much’ (Kimball 1991: 47-50).

cihbí:c-á:ho:si-toho-:li-:s → cihbi:cá:hostoho:li:s
 thick-ADV-REALIS-DEDUC-IPAST
 ‘One can deduce that it [the snow] is lying thickly’.

talásba-:si-tíkko-:s → talásbastíkko:s
 be.thin-DIM-3NEG(3CII)-IPAST
 ‘It is not very thin.’

ilkoyóhl-o:si-tíkko-V → ilkoyóhlostíkko
 move-DIM-3NEG(3CII)-PHR:TERM
 ‘She is not moving even a little bit.’

camałátko-Vhco-:si-Vhco-V → camałátkóhcoso (sic)
 1SSTATS-be.afraid(SG)-3NEG(2A)-HABIT-DIM-HABIT-PHR:TERM (sic)
 ‘I am not even a little bit afraid.’

í:pa-fíhna-tílk → í:pafíntílk
 eat-ADV-1PLS(3CII)
 ‘We overeat.’

afán-hákko-má:mi-Vhco-V → afáhákkomáhco
 meet-1SNEGS(3A)-DUBIT-HABIT-PHR:TERM
 ‘I never met him’

kanomá:mi-Vhci → kanomáhci
 be.beautiful-PROGRESSIVE
 ‘It is beautiful.’

These alternations can be handled by a set of morpheme relationships which formalize the strength of suffixes such as *-toho*, *-toha*, etc. relative to verb roots ending in *-li* and to other suffixes such as *-osi*. The relationships would trigger movement along size scales, which would be constructed along a cline of length: [yomáhli] is longer than [yomáh], [á:ho:si] is longer than [á:ho:s], and so on. In other words, Koasati exhibits partial blocking. The only difference between Hupa and Koasati is that the latter does not have a comparable example of total blocking. This is of no consequence for the theory advocated here, which analyzes either type of blocking as a downsizing movement on the size scale.

West Greenlandic (Fortescue 1984) also exhibits partial blocking, with a twist. In this language, suffixes fall into two basic classes. “Truncating” suffixes delete the final consonant of the stem to which they attach. Most affixes with initial /q, k, ng, r/ or a double C or cluster or a vowel follow this pattern (1984: 351).

nirisassaq-kit-pput	→	<i>nirisassakipput</i>	‘they have little food’
inuk-piluk	→	<i>inupiluk</i>	‘bad man’

“Additive” suffixes are so-called because they exhibit what looks like total assimilation of the stem-final consonant rather than its deletion. Suffixes with an initial /n, s/ are usually additive (1984: 344).

urnig - niar - vaa	→	urninniarpaa	‘he will come to him’
tuqut - sinnaa - vaa	→	tuqussinnaavaa	‘he can kill it’
Nuuk - piaoq	→	Nuuppiaoq	‘the real Nuuk’

Some otherwise homophonous suffixes are distinguished only by their additive versus truncating behavior. This can be seen with the fourth person singular relative possession marker *mi* (1988: 345) in combination with the root *panik* ‘daughter’ (1988: 352).

<i>panimmi</i>	‘his daughter’s’	from <i>panik</i> ‘daughter’
<i>panimi</i>	‘his daughters’	

In terms of morpheme contact relationships, we can analyze both the additive and the truncating suffixes as strong morphemes, which trigger downsizing in the root.

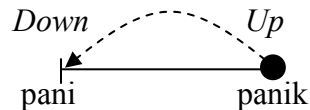

The “additive” morphemes, however, are extra strong. There is no way to manifest this contact relationship by further downsizing the root, which has only two allomorphs on its scale. Therefore, they manifest the extra contact relationships by undergoing upsizing along their own scale.

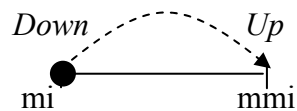

6. Concluding remarks

The purpose of this chapter has been to show that morpheme blocking can be partial, as predicted by the Resizing Theory. This point was demonstrated most clearly in Hupa, where partial segmental allomorphs exist along a cline with full and null segmental allomorphs, and in Kanura, where a partial tone allomorph exists along a cline with a tone+segment and a null allomorph. Establishing the existence of partial allomorphs

alongside total ones also allowed us to offer straightforward accounts of truncating behavior in Koasati and Western Greenlandic.

Chapter 5: Beyond length and beyond morphemes

1. Introduction

While the empirical focus of this study has been the dimension of length, and constituents which are morphemes, Resizing Theory is also intended to encompass other dimensions and other constituent types. That is, Resizing Theory makes a general claim that the relative size of a constituent can play a role in grammar. In this chapter, then, I sketch some ways in which the predictions of Resizing Theory are borne out in another domain, namely that of tone.

Tones enjoy a certain amount of fame within phonological theory because of the wide variety of changes that they undergo when they come into contact with one another, and tone sandhi has been an active area of research (for overviews see Chen 2000, Yip 2002). In the context of Resizing Theory, one of the things that makes tones interesting is the fact they form both a dimension and a constituent at the same time. In the data we examined in previous chapters, the relevant dimension (length) and the constituents (morphemes) were made of fundamentally different stuff. In the data that we will examine below, however, the relevant dimension (tone) and the constituents (tones) are made of fundamentally the same stuff -- viz., changes in pitch that are meaningful to the grammar. (For a re-analysis of tonal phenomena that similarly embraces the concept of tone changes, see Clark 1978).

Recall the three primary predictions of Resizing Theory. First, upsizing (or downsizing) alternations should all pattern together. Second, contact relationships can determine surface outputs when phonological processes, strictly defined, fail to do so.

And third, contact relationships exist along cline of heights, which should be reflected by a cline of sizes in the surface variants of a particular element. In the sections that follow, I provide evidence in support of these predictions within the tonal domain.

2. Phonological alternations in the service of higher effects

Resizing Theory predicts that alternations which upsize (or downsize) should all pattern together. In the length dimension this means that epenthesis, gemination, and devoicing can all serve the same higher-order requirement, as can deletion, degemination, and voicing. In the tonal dimension, this means that shifts toward higher tones should pattern together; likewise, shifts toward lower tones should also pattern together. Let us begin with a straightforward example which bears out this prediction.

2.1 Downsizing in Dananshan Hmong

Dananshan Hmong (Mortensen 2006, from Wang 1985 and Niederer 1998) has four level tones, \uparrow H (super-high), H, M, L and four contour tones, HM, MH, ML, LM. The tones HM and ML, which form the natural class of falling contours, trigger sandhi in which a \uparrow H lowers to H.

Dananshan Hmong (Mortensen 2006: 73)

ntou ^{HM}	‘cloth’	sa ^{\uparrowH}	‘blue’	ntou ^{HM} sa ^H	‘blue cloth’
tʃi ^{HM}	‘five’	teu ^{\uparrowH}	‘peck’	tʃi ^{HM} teu ^H	‘five pecks’
ku ^{ML}	‘trench’	tʃe ^{\uparrowH}	‘house’	ku ^{ML} tʃe ^H	‘sewer’
nqai ^{ML}	‘flesh’	tle ^{\uparrowH}	‘dog’	nqai ^{ML} tle ^H	‘dog flesh’

The same falling contours also trigger sandhi in which a H lowers to M.

Dananshan Hmong (Mortensen 2006: 73)

au ^{HM}	‘two’	pua ^H	‘hundred’	au ^{HM} pua ^M	‘two hundred’
plou ^{HM}	‘hair’	npua ^H	‘pig’	plou ^{HM} npua ^M	‘pig hair’
nplou ^{ML}	‘leaf’	nton ^H	‘tree’	nplou ^{ML} nton ^M	‘tree leaf’
na ^{ML}	‘year’	ɕou ^H	‘year’	na ^{ML} ɕou ^M	‘year’

Sandhi in Dananshan Hmong bears out the predictions of Resizing Theory because the alternations from $\uparrow H$ to H, and from H to M, both occur in the same environment, and both shift tones lower. In other words, sandhi triggers downsizing of the level tone.

The analysis of Dananshan Hmong draws from Mortensen (2006), although I recast it in the terms of Resizing Theory. The following contact relationship can be posited.

Falling tones \triangleright Level tones

“The boundary between a falling tone and a following level tone requires relative strengthening on its left side and/or relative weakening on its right.”

In this relationship, the constituents in contact are individual tones. The falling tones HM or ML lie on the left edge of the boundary, and the level tones $\uparrow H$ or M lie on the right edge.

Contact relationships drive changes in the relative size of a constituent, triggering movement on ordered scales such as the following.

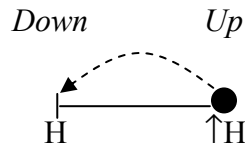

Recall from Chapter 1 that we defined a SCALE as an ordering of the surface variants of a linguistic constituent along a particular dimension. Here, the surface variants of $\uparrow H$ are

ordered along the dimension of tone, such that the upsizing end of the scale represents the highest-tone variant and the downsizing end represents the lowest-tone variant. Recall too that we defined the STARTING POINT for scalar movement as that variant which would occur when *no* contact relationship is operative; in this case, the starting point is presumably the underlying form, represented by the black circle.

The scale and starting point for the H tone is constructed in exactly the same way.

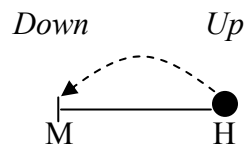

The two different alternations, from \hat{H} to H and from H to M, are thus unified as downsizing alternations resulting from a single contact relationship.

One question concerns underlying M tones, which apparently do not undergo downsizing to L. In Resizing Theory, this fact could potentially be handled in two different ways: either M tones could be excluded from the contact relationship altogether (such that the revised relationship would be “Falling tones $\triangleright \hat{H}, H$ ”), or M tones could have single-point scales that do not allow for any movement (see the discussion of single-point scales for Turkish roots in Chapter 2, §2.7). The choice between these analyses does not, as far as I can tell, have empirical consequences for the particular case of tone sandhi we are examining, but it does have philosophical consequences. Recall that scales in Resizing Theory can be non-isomorphic to one another just when the difference between them can be phonologically defined. Thus, the length scales in Pāri (Chapter 1) are non-isomorphic to one another, and the difference between them is defined according to place of articulation (scales for roots ending non-velar consonants contained voiced

versus voiceless variants, while scales for roots ending in velar consonants contained \emptyset versus [k] variants).

If we were to propose the scalar-based solution for Dananshan Hmong, therefore, we would want to be able to demonstrate a straightforward phonological difference between \uparrow H and H on the one hand, and M and L on the other hand -- in other words, we would want to say that \uparrow H and H form a natural class of tones. If, on the other hand, we were to propose the relationship-based solution, we would essentially be claiming that \uparrow H and H form an arbitrary grouping of tones in the language, similar to the arbitrariness of noun classes and verb classes that we witnessed in our consideration of morphemes as constituents. Further data from tonal alternations in Dananshan Hmong would be required to determine which of these approaches is most appropriate.

2.2 Downsizing in Eastern A-Hmao

Eastern A-Hmao (Mortensen 2006) is related to Dananshan Hmong, both languages being members of the Far-Western Hmongic group, and is of interest because it presents a variation on the Dananshan Hmong pattern. In Eastern A-Hmao, the H and MH tones triggers downsizing of the following tone, such that H becomes M.

Eastern A-Hmao (Mortensen 2006: 83)

tu ^H	‘son’	ki ^H	‘grandchild’	tu ^H ki ^M	‘descendants’
mau ^H	‘Miao’	sa ^H	‘Han’	mau ^H sa ^M	‘citizenry’
yfiu ^{MH}	‘lusheng’	su ^H	‘sound’	yfiu ^{MH} su ^M	‘lusheng sound’
lfi ^{MH}	‘long time’	nti ^H	‘long’	lfi ^{MH} nti ^M	‘for a long time’

Furthermore, the same sandhi environment also triggers downsizing such that M becomes L.

Eastern A-Hmao (Mortensen 2006: 83)

ti ^H	‘land’	tɕœy ^M	‘place’	ti ^H tɕœy ^L	‘location’
qu ^H	‘old’	tʂho ^M	‘clothing’	qu ^H tʂho ^L	‘old clothing’
nfie ^{MH}	‘year’	ɕau ^M	‘year’	nfie ^{MH} ɕau ^L	‘age’
dʒfie ^{MH}	‘animal’	mpa ^M	‘pig’	dʒfie ^{MH} mpa ^L	‘beast of burden’

Thus, Sandhi in Eastern A-Hmao bears out the predictions of Resizing Theory because the alternations from H to M, and from H to L, both occur in the same environment, and both shift tones lower.

The contact relationship for Eastern A-Hmao is interesting because the left-hand members of the relationship, H and MH, do not form a natural class. This suggests that the ‘natural class’ of falling contours which we invoked for the Dananshan Hmong relationship is coincidental and that, just as the grouping of morphological constituents within contact relationships can be arbitrary, so can the grouping of tonal constituents. This also suggests a solution to the philosophical quandary concerning the appropriate analysis of tones that do not alternate in Dananshan Hmong; they are simply excluded from the contact relationship. The arbitrariness of constituent groupings is reflected in the contact relationship for Eastern A-Hmao.

$\boxed{H, MH} \triangleright \boxed{H, M}$

“The boundary between a H or MH tone and a following H or M tone requires relative strengthening on its left side and/or relative weakening on its right.”

What is not arbitrary, of course, is the movement along the size scales for the H and M tones, which crucially occurs only in the downsizing direction.

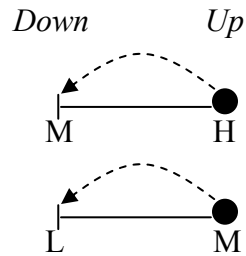

It should be noted that Mortensen (2006) provides further examples of tonal sandhi which are notably more complex. In Xinzhai Hmong (2006: 84 from Xian 1990, Niederer 1998), for example, sandhi triggers changes to contour tones whereby MH becomes LM, but LM becomes ML. The first change could be described as downsizing (i.e., tone lowering) but the second one cannot; it looks more like metathesis. Shuijingping Hmong offers a similarly perplexing set of changes whereby a HM contour becomes \hat{H} , but \hat{H} becomes H. In another set, LML becomes MH, but MH becomes ML.

Mortensen draws on such examples to argue that the scalar arrangement of tones, or other constituents, does not make reference to any external parameter but occurs in an inherently abstract fashion. My own view is that while these alternations do not immediately suggest such an external parameter, they do not rule one out, either. The fact that the Xinzhai Hmong and Shuijingping Hmong examples almost exclusively concern contour tones suggests that something more complex than scalar arrangement may be going on here. It could be, for example, that tonal upsizing and downsizing in these languages are accompanied by another alternation that is not strictly size-based, just as consonantal length upsizing and downsizing are frequently accompanied by changes in manner (e.g., from fricative to stop). If such a reanalysis is not possible, then we must

carefully distinguish between two types of scale in human language: those which must be learned on a case-by-case basis, as in Xinzhai Hmong, and those which may be learned with a more general strategy that makes reference to the same size-based algorithm every time, as in Eastern A-Hmao.

2.3 Downsizing in Makaa

Makaa (Heath 1991) exhibits an interesting tonal alternation that combines tonal downdrift and consonant-tone interactions. The phenomenon of downdrift has been widely studied (see among others Clements 1979, Hyman 1979, 1985b, Yip 1980, Carlson 1983, Snider 1990, 1998, Liberman et al. 1993). Canonically, downdrift refers to a lowering of high tones that typically occurs in sequences of HLH. In this environment, the second H is realized at a somewhat lower pitch than the previous H, as indicated schematically below.

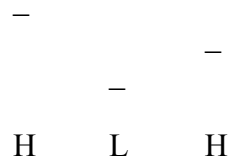

The lowered H is represented with an exclamation point, thus HLH → HL!H.

The phenomenon of consonant-tone interactions have also been the subject of discussion in the literature (e.g. Hyman 1973, Bradshaw 1998). The typology of such interactions is described in detail by Bradshaw (1998), but for our purposes it suffices to note that a) it is typically voiced stop consonants which interact with tone and b) such consonants, often referred to as “depressors”, usually occur concomitant with low tones or have a lowering effect on surrounding tones.

With this background, we can examine Makaa, where the consonants [d] and [g] are depressors which interact with tones in associative noun constructions. There are ten noun classes in Makaa and the associative marker (AM), as well as the class prefix, differs for each class. The variants of the associative marker that we will be concerned with are [ó], used for Class 6 nouns such as ‘corner’ and Ø, used for Class 1 nouns such as ‘animal’ and Class 7 nouns such as ‘broth’.

First consider the case in which a depressor consonant comes into contact with an overt associative marker [ó] (all data are from Heath 1991: 15-16).

/ò-káámbúg ó-mè-bágó/ → [ò-káámbúg !ó móbágó] ‘ants of the corners’
 L HH H H L HH L HH H !H H H H
 CL ant AM-CL-corner

The depressor consonant, [g] is the final segment of *káámbúg* ‘ant’. It is followed by the associative marker, [ó], which possesses both its own tone (H) and its own segmental content [o]. The point of interest is the fact that downdrift that occurs on [ó], rendering it [!ó] on the surface. (Note too that the H of the associative spreads de-links the following L tone and spreads rightward, a process that does not appear to interact crucially with downdrift).

We know that this downdrift results from contact between the depressor and the following associative marker because, in a minimally different situation where a vowel intervenes between a depressor and H, downdrift does not occur.

/ò-cúdú ó-mè-bágó/ → [òcúdú ó mèbágó] ‘animals of the corners’
 L HH H L HH
 CL-animal AM-CL corner

The noun *cúdí* ‘animal’ contains a potential depressor consonant [d], but we see no downdrifting effect on the associative [ó], because a vowel intervenes these two constituents. Indeed, we see no downdrifting effect on the final [ú] of *cúdí*, either, suggesting that depressors enter into a relationship specifically with the associative and not with any other constituent.

We can therefore propose that downdrift is the result of a contact relationship such as the following.

Depressors▷AM

“The boundary between a depressor consonant and a following associative marker requires relative strengthening on its left side and/or relative weakening on its right.”

This relationship represents a requirement of the Makaa grammar. The requirement can be satisfied by downsizing the associative marker in the tonal dimension. This is what occurs in the examples above, where an associative marker that consists of an H tone undergoes downdrifting to !H. Resizing Theory predicts, however, that the requirements of the contact relationship could also be satisfied by other amounts of downsizing: it is the fact of a change, and not the amount, which is important.

Makaa bears out this prediction in an interesting way. Recall that for Class 1 and 7 nouns, the associative marker is ∅ -- that is, it has no tonal or segmental content. In these cases, the contact relationship “Depressors▷AM” gets realized by the *insertion* of a full-fledged L tone, concomitant with the insertion of a vowel to bear it.

/káámbúg ∅ cáanzó/ HH H HH H ant AM broth	→ /káámbúg ù cáanzó/ HH H L HH H	‘ant of the broth’
---	-------------------------------------	--------------------

/káámbúg ∅-∅- <i>cúdí</i> /	→ [káámbúg ù <i>cúdí</i>]	‘ant of the animal’
-----------------------------	----------------------------	---------------------

HH H L HH
ant AM animal

HH H L HH

Thus, two types of alternation satisfy the contact relationship in Makaa: a change from H to !H, or the insertion of L. Both have the effect of downsizing the associative marker in the tonal dimension.

2.4 Upsizing in Krachi

Krachi (Snider 1990) exhibits tonal upstep, or the raising of H tones. That is, under certain conditions, an H tone is realized at a somewhat higher pitch than previous H tones. The very existence of upstep, which has been documented in other languages such as Engenni and Acatlán Mixtec (see citations in Yip 2002), is interesting because Resizing Theory predicts mirror-image alternations. That is, if downdrift or downstep is attested then we expect upstep to be as well. As we saw in previous chapters, both upsizing and downsizing do in fact occur in the length dimension; Krachi and other upstepping languages confirm that both also occur in the tonal dimension. This prediction distinguishes Resizing Theory from other approaches, such as Ohala's articulation-based theory of velar deletion, which predict that change only occurs in one direction.

However, upstep in Krachi is also interesting for its own reasons. As documented by Snider (1990), upstep occurs in only a single environment (and furthermore, this environment always triggers upstep), as follows.

/H # L H/ → H # H ↑H

That is, when a H tone precedes a L H sequence across a word boundary, the L H sequence changes to H \uparrow H, where the upward arrow indicates an upstepped tone.

Examples demonstrating upstep are below.

Krachi (Snider 1990: 458)

	— — — — —		
óká kɛ́ɲísí	→	óká kɛ́ɲísí	‘wife’s eye’
		— — — —	
àlí kòtóná	→	àlí kòtóná	‘our mat’
		— — — —	
òyú kɛ́ɲíní	→	òyú kɛ́ɲíní	‘thief’s name’

I interpret these data as the upsizing of the first two tones in the second word. That is, there is a general requirement for these tones to upsize in the tonal dimension. The L tone meets this requirement by raising to H, and the second tone meets this requirement by raising to \uparrow H. In this sense, there is a functional equivalence between the surface high and the upstepped high, and Krachi bears out the predictions of our theory. (An alternative, and perhaps more felicitous, analysis would be to say that the entire word upsizes except for the final tone, which is extra-prosodic -- testing this analysis would require words longer than three syllables, which are not in the data set provided in Snider [1990]).

It should be noted that Snider himself provides a very different analysis. He claims that the surface H on the first syllable of words like *kɛ́ɲísí* results from a process of L delinking, followed by rightward H spread. His analysis has the advantage of

concurring with data from other languages in the Oti Guang group, which all exhibit L delinking and H spread (but no upstep) in the same environment. The Resizing Theory analysis, on the other hand, has the advantage of unifying the two tone alternations under a single rubric, rather than treating the $L \rightarrow H$ and $H \rightarrow \uparrow H$ as separate processes.

3. Taking some phonology out

A second prediction of Resizing Theory is that contact relationships can determine surface outputs when phonological processes, strictly defined, fail to do so. In previous chapters, we saw how morpheme contact relationships could drive alternations when phonology did not. In this section, we will examine how contact relationships between tones can do the same thing. Our focus will be on downdrift, which we have already touched on briefly, and downstep. In order to see how such processes provide evidence for the predictions of Resizing Theory, we will first consider a textbook case of downdrift and downstep, which can be attributed straightforward assimilation. We will then move on to more complex cases, which I will argue can only be attributed to the effects of contact.

3.1 Phonology as we know it: Downdrift and downstep triggered by L

Like downdrift, downstep refers to the lowering of H tones. Unlike downdrift, however, downstep does not require the presence of an overt L in order to occur. That is, the surface HLH sequence that triggers downdrift is not required for downstep. Because of the similarity between the two processes, downstep is often analyzed as resulting from

a floating L tone, rather than an overt L tone. In many languages, there is evidence that this analysis is correct.

Consider Bimoba (Snider 1998). In the example that follows, the overt L on [gò] triggers downstep of the following H tone, which is bolded.

Bimoba (Snider 1998: 81)
 gbát-úk gòt-í pòr-ùk ‘a bushbaby is looking at a spider’
 bushbaby-NC look.at-Pres spider-NC

— — — —
 — —
 [gbá túk gò !rí pò rùk]

This is a canonical case of downdrift. The presence of an L lowers a following H. This process can reasonably be considered as a case of phonological assimilation, whereby the lowness of L partially spreads to the following H.

In Bimoba, segmental processes can cause the deletion of a tone-bearing unit. When this happens, L tones may be set free to float. Although unrealized on the surface, these H tones also have the effect of lowering a following H.

Bimoba (Snider 1998: 82)
 gbát-úk ηmít-ṭ gbát-úk ‘a bushbaby cut a bushbaby’
 bushbaby-NC cut-Past bushbaby-NC

— — — —
 — —
 [gbá túk ηmít !gbá túk]

Here, the segmental /t/ of the past tense suffix deletes when it follows a root-final /t/. The L tone of the past tense is therefore delinked from segmental material. Although the L is floating, it exerts its effect on the following H by downstepping it. Again, this process can

reasonably be considered as a case of assimilation, or “phonology as we know it”, whereby the lowness of the floating L partially spreads to the following H.

3.2 *Not phonology as we know it: Downdrift triggered by H*

Not all cases of downdrift look like what we saw in Bimoba. In a number of languages, downdrift is triggered not by an L tone, but by an H tone. These languages include Kishambaa, Temne, and Supyire (Odden 1995). Consider the following examples from Supyire (Carlson 1983, 1994) where the bold indicates the downstepped tones (schematic tone profiles are provided according to the source).

kà u ú kú !wíí	—	Carlson 1983: 36
and he SEQ it look at	— —	
‘and he looked at it’	—	
kà u ú ú !yíbé...		Carlson 1994: 72
and s/he NARR him/her ask		
‘Then s/he asked him/her...’		

In both cases, it is the presence of the previous H which triggers downdrift on a subsequent H. According to Carlson (1983), downdrift in Supyire makes no reference to an underlying L tone; that is, there is no evidence for a floating L in the examples above. This suggests that our earlier characterization of downdrift as an assimilatory process (e.g., in Bimoba) was incorrect. If an H tone is just as capable of triggering downdrift as an L tone, then it is the fact of a *relationship* between two tones in contact that is important, not the actual “content” of the triggering tone.

We can analyze Supyire in Resizing Theory with the following contact relationship.



“The boundary between a H tone and a following H tone requires relative strengthening on its left side and/or relative weakening on its right.”

This contact relationship triggers downsizing on the rightmost H tone, which is realized via downdrifting to !H. Importantly, there is nothing about the *content* of the constituents on either side of the relationship which would predict downsizing: both tones are H, and both tones begin life with the same size in the tonal dimension. It is the fact of their *contact* that introduces resizing on one of the tones.

The fact that languages like Supyire exist suggests that the triggering of downdrift and downstep by L in Bimoba is coincidental. That is, there is nothing inherent in the content of L that triggers downstep; rather, it is the relationship between L and the following tone that is important. This idea is further supported by the existence of languages such as Bamileke-Dschang (Hyman 1985b) which exhibit downstep but not downdrift. If, as in Bamileke-Dschang, H tones lower somewhat in the absence of an overt L, but fail to lower in the presence of an overt L, then it cannot be the inherent “lowness” of an L tone that is responsible for the process. In other words, it is not phonology as we know it which dictates these processes, but something higher and more abstract, namely contact.

4. Clines

A third prediction of Resizing Theory is that contact relationships exist along cline of heights, which should be reflected by a cline of sizes in the surface variants of a particular element. This prediction is borne out by Igbo, a language in which downdrift

reportedly imposes twice as much lowering as downstep (Lieberman et al. 1993), such that there is a cline of downsizings along the tonal dimension.

In their study, Liberman et al. (1993) conducted acoustic measurements of Igbo tones, using words as well as pairs of phrases like those shown below. The notation system that they use for marking tones is different from what we have seen in previous examples in this chapter. An acute accent indicates H and a grave accent indicates L. An unmarked syllable indicates the continuation of the previous tone. A repeated H is interpreted as M, which is a downstepped H (identical to !H).

Igbo (Lieberman et al. 1993: 149)

Phenomenon	Example	Surface tones
Downdrift	Íke nà Áma	HH L HH
Downstep	Díké nà Áma	HM L HH
Downdrift	Ólùkà ọma	HLH HH
Downstep	Ọnú ọma	HM HH
Downdrift	Ábànòbì ọma	HLHL HH
Downstep	Ọnwùkà ọma	HHM HH

According to Liberman et al. (1993) as well as Clark (1978: 123), downstep in Igbo is lexically marked. Thus, tone lowering on the second syllable of a word like *Díké* is part of what distinguishes it from the minimally different *Íke*, which exhibits no drop.

Furthermore, there is no evidence for a floating L in words like *Díké*.

The Igbo speaker in Liberman et al.'s study produced a wide pitch range variation by saying each stimulus word and phrase in three conditions: addressed quietly to someone seated nearby, addressed to someone seated on the other side of a table (~1 meter away), and addressed to someone at the other end of a room (~10 meters away).

Their results show that “downdrift imposes roughly twice as much lowering as downstep

does” (1993: 156). They report the results in terms of regression co-efficients; the slope for the HLH (downdrift) condition is 0.824, while the slope for the HM (downstep) condition is 0.924.

This suggests that tone contact relationships in Igbo exist along a cline of heights, in line with the predictions of Resizing Theory. We can model these relationships as follows.

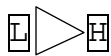

“The boundary between a L tone and a following H tone requires a lot of relative strengthening on its left side and/or relative weakening on its right.”



“The boundary between a H tone and a following H tone requires relative strengthening on its left side and/or relative weakening on its right.”

In other words, the relationship between downdrift and downstep in Igbo is similar to the relationship between root variants [ɾɔk^wé, dɔk^wé, tɔk^wé] in T^hese, and to the relationship between the perfective variants [win, wi, n, Ø] in Hupa. These surface variants differ only in their relative size, just as downdrifted and downstepped tones in Igbo differ only in their relative size.

Other instrumental studies, such as Snider’s (1998) investigation of Bimoba, have demonstrated that downdrift and downstep exert the same amount of lowering. Nothing in Resizing Theory rules out such a language; but the fact that lowering occurs by different amounts in Igbo shows that Bimoba must be considered a variation on a broader theme.

There is another way to view the Igbo data, namely as a combination of a tonal contact relationship and a more local, assimilatory relationship. The thinking goes as

follows. The general contact relationship $H \triangleright H$ would account for downstep. Meanwhile, an assimilatory process could lower tones even further: as predicted by general locality conditions in phonology, this occurs just when an L tone is present. Thus, the combination of the contact relationship and L assimilation accounts for downdrift. This account would correctly predict the directionality of the Igbo data, namely that downdrift is lower than downstep. Furthermore, it would predict a typology of relationships between downdrift and downstep. In languages such as Bimoba, tone lowering is due to a single contact relationship; therefore, downdrift and downstep occur in equivalent amounts. In languages such as Igbo, tone lowering can be due to the *additive* effects of a contact relationship and a local, assimilatory process; therefore, downdrift has a greater effect than downstep. A language in which downstep has a greater effect than downdrift, however, is not predicted.

5. Conclusion

Tone makes an interesting companion to length because both are dimensions which have a continuous physical realization. Phonological grammars impose categories upon this continuity, creating categories and oppositions such as short *vs.* long or high *vs.* low. We know that such categorization takes place because no language exhibits millisecond-by-millisecond distinctions in the length dimension, or Hertz-by Hertz distinctions in the tone dimension. Still, what this study has attempted to suggest is that the categorizations that linguistic theory has imposed upon these dimensions have been too rigid. Placing all length changes into boxes labeled either short or long obfuscates the underlying unity of certain patterns, as I have tried to show by marshalling evidence from

gemination, epenthesis, and devoicing. Furthermore, placing all tone changes into boxes labeled either low or high suffers from the same problem, as I have tried to show by marshalling evidence from tonal chain shifts, downdrift, and downstep. Taking the “bird’s eye” view of such alternations, as Resizing Theory does, allows us to transcend such categories without denying their existence. Furthermore, grounding these alternations in contact relationships rather than traditional phonological processes frees us, on the one hand, from the overly burdensome requirement that surface phonological changes result from natural, assimilatory interactions but allows us, on the other hand, to see how such alternations are natural in another way, because they manifest themselves in clines.

References

- Abramson, Arthur S. 1986. The perception of word-initial consonant length: Pattani Malay. *Journal of the International Phonetic Association* 16: 8-16.
- Andersen, Torben. 1988. Consonant alternation in the verbal morphology of Pãri. *Afrika und Übersee* 71: 63-113.
- Anderson, Heather. 1997. The optimal compound: Optimality theory and the typology of synthetic compounds. In Stuart Davis (ed.) *Optimal Viewpoints*. Bloomington, IN: Indiana University Linguistics Club Publications.
- Anderson, Stephen. 1986. Disjunctive ordering in inflectional morphology. *Natural Language and Linguistic Theory* 4: 1-31.
- Anderson, Stephen. 1992. *A-Morphous Morphology*. Cambridge University Press.
- Aoyama, Katsura and Lawrence A. Reid. 2006. Cross-linguistic tendencies and durational contrasts in geminate consonants: An examination of Guinaang Bontok geminates. *JIPA* 36(2): 145-157.
- Aronoff, Mark. 1976. *Word Formation in Generative Grammar*. Cambridge, MA: MIT Press.
- Arvaniti, Amalia and Georgios Tserdanelis. 2000. On the phonetics of geminates: Evidence from Cypriot Greek. *Proceedings of 6th International Conference on Spoken Language Processing*, Vol 2: 559-562. Beijing, China.
- Asher, R.E. and T.C. Kumari. 1997. *Malayalam*. New York: Routledge.
- Bauer, Laurie. 1988. What is lenition? *Journal of Linguistics* 24: 381-392.
- Beckman, Jill. 1997. Positional faithfulness, positional neutralisation, and Shona vowel harmony. *Phonology* 14(1): 1-46.
- Blevins, Juliette. 2004a. *Evolutionary Phonology*. Cambridge University Press.
- Blevins, Juliette. 2004b. Klamath sibilant degemination: Implications of a recent sound change. *International Journal of American Linguistics* 70(3): 279-289.
- Bradshaw, Mary. 1999. A Crosslinguistic Study of Consonant-Tone Interaction. Doctoral dissertation, Ohio State University.
- Caballero, Gabriela, Michael J. Houser, Nicole Marcus, Teresa McFarland, Anne Pycha, Maziar Toosarvandani, Suzanne Wilhite, and Johanna Nichols. Submitted. Nonsyntactic ordering effects in syntactic noun incorporation.
- Carlson, Robert. 1983. Downstep in Supyire. *Studies in African Linguistics* 14(1): 35-45.
- Carlson, Robert. 1994. *A Grammar of Supyire*. New York: Mouton de Gruyter.
- Carmack, Stanford. 1997. Blocking in Georgian verb morphology. *Language* 73(2): 314-338.
- Casali, Roderic F. 1997. Vowel elision in hiatus contexts: Which vowel goes? *Language* 73(3): 493-533.
- Chelliah, Shobhana L. 1997. *A Grammar of Meithei*. New York: Mouton de Gruyter.
- Chen, Matthew Y. 2000. *Tone Sandhi: Patterns Across Chinese Dialects*. Cambridge University Press.
- Clark, Mary. 1978. A Dynamic Treatment of Tone, With Special Attention to the Tonal System of Igbo. Doctoral dissertation, University of Massachusetts, Amherst.
- Clements, George N. 1979. The description of terraced-level tone languages. *Language* 55(3): 536-558.

- Clements, George N. 1986. Compensatory lengthening and consonant gemination in LuGanda. In Leo Wetzels & Engin Sezer (eds.) *Studies in Compensatory Lengthening*. Dordrecht: Foris.
- Clements, G.N. and Keyser, S.J. 1983. *CV Phonology: A Generative Theory of the Syllable*. Cambridge, MA: Linguistic Inquiry Monographs.
- Cohen, Kevin Bretonnel. 2000. *Aspects of the Grammar of Kukú*. Lincom Studies in African Linguistics 25. Munich: Lincom Europa.
- Comrie, Bernard. 1997. Turkish phonology. In Alan S. Kaye (ed.) *Phonologies of Asia and Africa*, Volume 2. Winona Lake, Indiana: Eisenbrauns. pp 883-898.
- Crazzolara, J.P. 1938. *A Study of the Acoolí Language: Grammar and Vocabulary*. London: Oxford University Press.
- Creissels, Denis. 1999. Remarks on the sound correspondences between Proto-Bantu and Tswana (S.31), with particular attention to problems involving *j (or *y), *ĩ and sequences *NC. In Jean-Marie Hombert and Larry M. Hyman (eds.) *Bantu Historical Linguistics: Theoretical and Empirical Perspectives*. Stanford, CA: CSLI Publications. pp 297-334.
- Crum, Beverly and Jon P. Dayley. 1993. *Western Shosoni Grammar*. Department of Anthropology, Boise State University.
- Davis, Stuart. 1994. Geminate consonants in moraic phonology. In Raul Aranovich, William Byrne, Susanne Preuss, & Martha Senturia (eds.) *WCCFL 13*: 32-45.
- Delattre, Pierre. 1971a. Consonant gemination in four languages: An acoustic, perceptual, and radiographic study. Part I. *International Review of Applied Linguistics in Language Teaching 9(1)*: 31-52.
- Delattre, Pierre. 1971b. Consonant gemination in four languages: An acoustic, perceptual, and radiographic study. Part II. *International Review of Applied Linguistics in Language Teaching 9(2)*: 97-113.
- Denes, P. 1955. Effect of duration on the perception of voicing. *JASA 27(4)*: 761-764.
- Dickens, Patrick R. 1977. Grammar simplification via rule inversion: the effect of historical deletion of nasals on modern Sotho. *African Studies 36*:161-170.
- Dickens, Patrick R. 1984. The history of so-called strengthening in Tswana. *Journal of African Languages and Linguistics 6*: 97-125.
- Doke, C.M. 1954. *The Southern Bantu Languages*. Oxford University Press.
- Elmedlaoui, Mohamed. 1993. Gemination and spirantization in Hebrew, Berber and Tigrinya: a 'Fortis-Lenis Module' analysis. *Linguistica Communicatio 5*: 55-64.
- Escure, Geneviève. 1977. Hierarchies and phonological weakening. *Lingua 43*: 55-64.
- Esposito, Anna and Maria Gabriella Di Benedetto. 1999. Acoustical and perceptual study of gemination in Italian stops. *JASA 106(4)*: 2051-2062.
- Faluschi, Simone and Maria-Gabriella Di Benedetto. ND. Acoustic analysis of singleton and geminate affricates in Italian. *The European Journal of Language and Speech*. Online at essex.ac.uk/websls
- Flemming, Edward. 2001. Scalar and categorical phenomena in a unified model of phonetics and phonology. *Phonology 18*: 7-44.
- Foley, James. 1977. *Foundations of Theoretical Phonology*. Cambridge University Press.
- Fortescue, Michael. 1984. *West Greenlandic*. Dover, NH: Croom Helm.
- Frantz, Donald G. 1991. *Blackfoot Grammar*. Toronto: University of Toronto Press.

- Gnanadesikan, Amalia. 1997. *Phonology with Ternary Scales*. Doctoral dissertation, University of Massachusetts, Amherst.
- Golla, Victor Karl. 1970. *Hupa Grammar*. Doctoral dissertation, University of California, Berkeley.
- Golla, Victor. 1996a. Sketch of Hupa, an Athapaskan language. In Ives Goddard (ed). *Handbook of North American Indians, Volume 17: Languages*. Washington, D.C: Smithsonian Institution. pp. 364-389.
- Golla, Victor. 1996b. *Hupa Language Dictionary*, Second Edition. Hoopa, CA: Hoopa Valley Tribal Council.
- Gordon, Matthew. 2001. A typology of contour tone restrictions. *Studies in Language* 25: 405-444.
- Gouskova, Maria. 2004. Relational hierarchies in Optimality Theory: the case of syllable contact. *Phonology* 21: 201-250.
- Haag, Marcia and Henry Willis. 2001. *Choctaw Language and Culture*. Norman: University of Oklahoma Press.
- Ham, William H. 2001. *Phonetic and Phonological Aspects of Geminate Timing*. Outstanding Dissertations in Linguistics Series. New York: Routledge.
- Hansson, Gunnar. 2001. Theoretical and typological issues in consonant harmony. Doctoral dissertation, University of California, Berkeley.
- Harris, John and Eno-Abasi Urua. 2001. Lenition degrades information: Consonant allophony in Ibibio. *Speech, Hearing, and Language: Work in Progress*. Volume 13. Department of Phonetics and Linguistics, University College London.
- Harrison, Sheldon P. with Salich Y. Albert. 1976. *Mokilese Reference Grammar*. Honolulu: University Press of Hawaii.
- Hayes, Bruce. 1986a. Inalterability in CV phonology. *Language* 62: 321-352.
- Hayes, Bruce. 1986b. Assimilation as spreading in Toba Batak. *Linguistic Inquiry* 17(3): 467-499.
- Hayes, Bruce. 1989. Compensatory lengthening in moraic phonology. *Linguistic Inquiry* 20: 253-306.
- Heath, Daniel. 1991. Tone in the Makaa associative construction. In Stephen C. Anderson (ed.) *Tone in five languages of Cameroon*. Arlington, TX: Summer Institute of Linguistics (SIL) & University of Texas at Arlington.
- Honeybone, Patrick. 2001. Lenition inhibition in Liverpool English. *English Language and Linguistics* 5:2: 213-249.
- Hume, Elizabeth, Jennifer Muller, and Aone van Engelenhoven. 1997. Non-moraic geminates in Leti. *Phonology* 14: 371-402.
- Hyman, Larry (ed). 1973. *Consonant Types & Tone*. Los Angeles: Southern California Occasional Papers in Linguistics, No. 1.
- Hyman, Larry. 1979. A reanalysis of tonal downstep. *Journal of African Languages and Linguistics* 1: 9-29.
- Hyman, Larry. 1985a. *A Theory of Phonological Weight*. Dordrecht: Foris.
- Hyman, Larry. 1985b. Word domains and downstep in Bamileke-Dschang. *Phonology* 2: 47-83.
- Inkelas, Sharon and Young-mee Yu Cho. 1993. Inalterability as prespecification. *Language* 69(3): 529-574.

- Inkelas, Sharon, Aylin Küntay, Orhan Orgun, and Ronald Sprouse. 2000. Turkish Electronic Living Lexicon (TELL). *Turkic Languages* 4: 253-275.
- Inkelas, Sharon and Cemil Orhan Orgun. 1995. Level ordering and economy in the lexical phonology of Turkish. *Language* 71(4): 763-793.
- Inkelas, Sharon and Cheryl Zoll. 2005. *Reduplication: Doubling in Morphology*. Cambridge University Press.
- Inkelas, Sharon and Cheryl Zoll. 2007. Is grammar dependence real? *Linguistics* 45:133-171.
- Jespersen, Otto. 1904. *Lehrbuch der Phonetik*. Leipzig & Berlin: Teubner.
- Jha, Sunil Kumar. 2001. *Maithili: Some Aspects of Its Phonetics and Phonology*. Delhi: Motilal Banarsidass.
- Jaeger, Jeri. 1978. Speech aerodynamics and phonological universals. In Jeri Jaeger et al. (eds.) *BLS* 4.
- Ka, Omar. 1994. *Wolof Phonology and Morphology*. Lanham, MD: University Press of America.
- Kahn, Daniel. 1976. *Syllable-Based Generalizations in English Phonology*. Doctoral dissertation, Massachusetts Institute of Technology.
- Kaisse, Ellen. 1986. Locating Turkish devoicing. *WCCFL* 5: 119-128.
- Kari, James. 1989. Affix positions and zones in the Athapaskan verb complex: Ahtna and Navajo. *IJAL* 55(4): 424-454.
- Karlssoon, Fred. 1999. *Finnish: An Essential Grammar*. Translated by Andrew Chesterman. New York: Routledge.
- Keating, Patricia. 1984. Phonetic and phonological representation of stop consonant voicing. *Language* 60: 286-319.
- Kenesei, István, Robert M. Vago and Anna Fenyevesi. 1998. *Hungarian*. New York: Routledge.
- Kenstowicz, Michael. 1982. Gemination and spirantization in Tigrinya. *Studies in the Linguistic Sciences* 12: 103-122.
- Kimball, Geoffrey D. 1991. *Koasati Grammar*. Lincoln, NE: University of Nebraska Press.
- Kirchner, Robert. 2000. Geminate inalterability and lenition. *Language* 76(3): 509-545.
- Kiparsky, Paul. 1973. 'Elsewhere' in phonology. In S. Anderson & P. Kiparsky (eds.) *A Festschrift for Morris Halle*. New York: Holt, Rinehart and Winston, 1973.
- Kiparsky, Paul. 1982. Lexical phonology and morphology. In In-Seok Yang (ed.). *Linguistics in the Morning Calm*. Seoul.
- Kiparsky, Paul. 2005. Blocking and periphrasis in inflectional paradigms. *Yearbook of Morphology 2004*. Dordrecht: Springer. pp 113-135.
- Kluender, Keith R., Randy L. Diehl, and Beverly A. Wright. 1988. Vowel-length differences before voiced and voiceless consonants: An auditory explanation. *Journal of Phonetics* 16: 153-169.
- Kohler, Klaus J. 1984. Phonetic explanation in phonology: The feature fortis/lenis. *Phonetica* 41: 150-174.
- Kraehenmann, Astrid. 2001. Swiss German stops: Geminates all over the word. *Phonology* 18: 109-145.

- Ladd, D. Robert and James M. Scobbie. 2003. External sandhi as gestural overlap? Counterevidence from Sardinian. In John Local, Richard Ogden, and Rosalind Temple (eds.) *Phonetic Interpretation: Papers in Laboratory Phonology VI*. pp 164-182.
- Lahiri, Aditi and Jorge Hankamer. 1988. The timing of geminate consonants. *Journal of Phonetics* 16(3): 327-338.
- Lees, Robert B. 1961. *The Phonology of Modern Standard Turkish*. Bloomington, IN: Indiana University Publications.
- Lehiste, Ilse. 1960. Segmental and syllabic quantity in Estonian. *American Studies in Uralic Linguistics*. Bloomington, IN: Indiana University Publications, Uralic and Altaic Series Volume 1.
- Lehiste, Ilse. 1970. *Suprasegmentals*. Cambridge, MA: MIT Press.
- Lehiste, Ilse, Katherine Morton, and M.A.A. Tatham. 1973. An instrumental study of consonant gemination. *Journal of Phonetics* 1: 131-148.
- Lewis, Geoffrey. 1967. *Turkish Grammar*. Oxford University Press.
- Lieberman, Mark, J. Michael Schults, Soonhyun Hong, & Vincent Okeke. 1993. The phonetic interpretation of tone in Igbo. *Phonetica* 50: 147-160.
- Lisker, Leigh. 1957. Closure duration and the intervocalic voiced-voiceless distinction in English. *Language* 33: 42-49.
- Lisker, Leigh. 1972. Stop duration and voicing in English. *Papers on linguistics and phonetics in memory of Pierre Delattre*. The Hague: Mouton. pp. 339-343.
- Lisker, Leigh. 1974. On time and timing in speech. In Thomas A. Seebeek (ed.) *Current Trends in Linguistics*, Vol. 12. The Hague: Mouton. pp. 2387-2418.
- Lisker, Leigh and Arthur S. Abramson. 1964. A cross-language study of voicing in initial stops: Acoustical measurements. *Word* 20 (3): 384-422.
- Lisker, Leigh, & Arthur S. Abramson. 1970. The voicing dimension: Some experiments in comparative phonetics. *Proceedings of the 6th International Congress of Phonetic Sciences*. Prague: Academia. pp. 563-567.
- Local, John and Adrian P. Simpson. 1999. Phonetic implementation of geminates in Malayalam nouns. *Proceedings of ICPhS 1999, San Francisco*. pp. 595-598.
- Lopes, Aurise Brandão and Steve Parker. 1999. Aspects of Yuhup phonology. *International Journal of American Linguistics* 65(3): 324-342.
- McCarthy, John J. 1986. OCP Effects: Gemination and anti-gemination. *Linguistic Inquiry* 17(2): 207-263.
- McCarthy, John J. and Alan S. Prince. 1993. Generalized alignment. In Geert Booij and Jaap van Marle (eds.) *Yearbook of Morphology*. pp 79-153.
- McCarthy, John J. and Alan S. Prince. 2005. Prosodic morphology. In John A. Goldsmith (ed.) *The Handbook of Phonological Theory*. Cambridge, MA: Blackwell. pp 318-366.
- McDonough, Joyce. 1999. On a bipartite model of the Athabaskan verb. In Fernald & Platero (eds.) *Athabaskan: Language & Linguistics*. Oxford University Press.
- McLaughlin, John Earls. 1987. *A Phonology and Morphology of Panamint*. Doctoral dissertation, University of Kansas.
- Mohanan, K.P. 1986. *The Theory of Lexical Phonology*. Dordrecht: D. Reidel.
- Mohanan, K.P. and Tara Mohanan. 1984. Lexical phonology of the consonant system in Malayalam. *Linguistic Inquiry* 15(4): 575-602.

- Muller, Jennifer S. 2001. The Phonology and Phonetics of Word-Initial Gemimates. Doctoral dissertation, Ohio State University.
- Muller, Jennifer S. 2002. On the theoretical implications of Cypriot Greek initial gemimates. *Journal of Greek Linguistics* 3: 115-137.
- Munro, Pamela and Felipe H. Lopez. 1999. San Lucas Quiaviní Zapotec Dictionary. Los Angeles: UCLA Chicano Studies Research Center.
- Newman, Paul. 2000. *The Hausa Language*. New Haven, CT: Yale University Press.
- Noonan, Michael. 1992. *A Grammar of Lango*. New York: Mouton de Gruyter.
- Obata, Kazuko. 2003. *A Grammar of Bilua*. Canberra: Pacific Linguistics.
- Odden, David. 1988. Anti Antigemination and the OCP. *Linguistic Inquiry* 19(3): 451-475.
- Odden, David. 1995. Tone: African languages. In John Goldsmith (ed.) *The Handbook of Phonological Theory*. Cambridge, MA: Blackwell.
- Ohala, J. J. 1997. Aerodynamics of phonology. *Proceedings of the 4th Seoul International Conference on Linguistics [SICOL]*, pp 92-97.
- Ohala, Manjari. 1983. *Aspects of Hindi Phonology*. Delhi: Motilal Banarsidass.
- Orgun, Cemil Orhan. 1999. Sign-Based Morphology: a declarative theory of phonology-morphology interleaving. In Ben Hermans & Marc van Oostendorp (eds.). *The derivational residue in phonological Optimality Theory*. Amsterdam: John Benjamins. pp. 247-67.
- Payne, Elinor M. 2005. Phonetic variation in Italian consonant gemination. *JIPA* 25(2): 153-181.
- Payne, Elinor and Efyhia Eftychiou. 2006. Prosodic shaping of consonant gemination in Cypriot Greek. *Phonetica* 63: 175-198.
- Podesva, Robert J. 2002. Segmental constraints on geminates and their implications for typology. Presentation at the annual meeting of the Linguistics Society of America.
- Port, R.F. and J. Dalby. 1982. Consonant/vowel ratio as a cue for voicing in English. *Perception and Psychophysics* 32: 141-152.
- Poulos, George and Louis J. Louwrens. 1994. *A Linguistic Analysis of Northern Sotho*. Pretoria, South Africa: Via Afrika.
- Pycha, Anne. (To appear, a). Morpheme strength relationships in Hupa and beyond. In T. Fernald & S. Tuttle (eds.) *Working Papers in Athabaskan Languages, No. 7*. Fairbanks: Alaska Native Languages Center.
- Pycha, Anne. (To appear, b). Partial blocking. *Proceedings of the Chicago Linguistic Society 41 (2005)*. Chicago: University of Chicago.
- Pycha, Anne, Sharon Inkelas & Ronald Sprouse. 2007. Morphophonemics and the lexicon: a case study from Turkish. In Maria-Josep Solé, Pam Beddor, & Manjari Ohala (eds.) *Experimental Approaches to Phonology*. Oxford University Press. pp 369-385.
- Rainer, Franz. 1988. Towards a theory of blocking: The case of Italian and German quality nouns. *Yearbook of Morphology*. pp 155-185.
- Raphael, Lawrence J. 1972. Preceding vowel duration as a cue to the perception of the voicing characteristic of word-final consonants in American English. *Journal of the Acoustical Society of America* 51(4), Part 2: 1296-1303.

- Raphael, Lawrence J. 1975. The physiological control of durational differences between vowels preceding voiced and voiceless consonants in English. *Journal of Phonetics* 3: 25-33.
- Raphael, Lawrence J. 1981. Durations and context as cues to word-final cognate opposition in English. *Phonetica* 38: 126-147.
- Raphael, Lawrence J., M.F. Dorman, Frances Freeman, and Charles Tobin. 1975. Vowel and nasal duration as cues to voicing in word-final stop consonants: Spectrographic and perceptual studies. *Journal of Speech and Hearing Research* 18(3): 389-400.
- Raphael, Lawrence J., Michael F. Dorman, and Alvin M. Liberman. 1980. On defining the vowel duration that cues voicing in final position. *Language and Speech* 23(3): 297-308.
- Rice, Keren D. 1990. Predicting rule domains in the phrasal phonology. In Sharon Inkelas & Draga Zec (eds.) *The Phonology-Syntax Connection*. University of Chicago Press.
- Rice, Keren. 2000. *Morpheme Order and Semantic Scope: Word Formation in the Athapaskan Verb*. Cambridge University Press.
- Rose, Sharon. 2000. Rethinking Geminates, Long-Distance Geminates, and the OCP. *Linguistic Inquiry* 31(1): 85-122.
- Rose, Sharon and Rachel Walker. 2001. A typology of consonant agreement of correspondence. *Language* 80: 475-531.
- Rubino, Carl Ralph Galvez. 2000. *Ilocano Dictionary and Grammar: Ilocano-English, English-Ilocano*. Honolulu: University of Hawai'i Press.
- Saltarelli, Mario. 1970. *A Phonology of Italian in a Generative Grammar*. The Hague: Mouton.
- Sapir, Edward. 1925. Sound patterns in language. *Language* 1(2): 37-51.
- Schaefer, R. 1982. A strengthening hierarchy for a morphophonemic process in Tswana. *Studies in African Linguistics* 13: 147-176.
- Schein, Barry and Donca Steriade. 1986. On geminates. *Linguistic Inquiry* 17(4): 691-744.
- Selkirk, Elizabeth. 1982. The syllable. In Harry van der Hulst & Norval Smith (eds.) *The Structure of Phonological Representations, Part I*. Dordrecht: Foris.
- Sharf, D.J. 1962. Duration of post-stress intervocalic stops and preceding vowels. *Language and Speech* 5: 26-30.
- Siptár, Péter & Miklós Törkenczy. 2000. *The Phonology of Hungarian*. Oxford University Press.
- Snider, Keith L. 1990. Tonal upstep in Krachi: Evidence for a register tier. *Language* 66(3): 453-474.
- Snider, Keith L. 1998. Phonetic realisation of downstep in Bimoba. *Phonology* 15: 77-101.
- Sohn, Ho-Min. 1994. *Korean*. New York: Routledge.
- Soukka, Maria. 2000. *A Descriptive Grammar of Noon, A Cangin Language of Senegal*. Munich: Lincom Europa.
- Steriade, Donca. 1997. Phonetics in phonology: the case of laryngeal neutralization. Manuscript, University of California, Los Angeles.
- Strooper, Harry. 1995. *A Grammar of Boraana Oromo (Kenya)*. Köln: Rüdiger Köppe Verlag.

- Tranel, Bernard. 1991. CVC light syllables, geminates and Moraic Theory. *Phonology* 8 (291-302).
- Trommer, Jochen. 2005. Polar tone in Kanuri. Manuscript.
- Turk, Alice. (1994) Articulatory phonetic clues to syllable affiliation: gestural characteristics of bilabial stops. In Patricia Keating (ed.) *Papers in Laboratory Phonology III*. Cambridge University Press. pp. 107-135.
- Underhill, Robert. 1976. *Turkish Grammar*. Cambridge, MA: MIT Press.
- Urua, Eno-Abasi Essien. 2000. *Ibibio Phonetics & Phonology*. Cape Town: Centre for Advanced Studies of African Society, CASAS Book Series No. 3.
- Vago, Robert M. 1980. *The sound pattern of Hungarian*. Washington, DC: Georgetown University Press.
- Valentine, J. Randolph. 2001. *Nishnaabemwin Reference Grammar*. University of Toronto Press.
- Vance, Timothy J. 1987. *An Introduction to Japanese Phonology*. Albany: State University of New York Press.
- Vennemann, Theo. 1972. Rule inversion. *Lingua* 29: 209-242.
- Williams, Edwin. 1981. On the notions "lexically related" and "head of a word". *Linguistic Inquiry* 12: 245-274.
- Williamson, Kay. 1977. Multivalued features for consonants. *Language* 53(4): 843-871.
- Wilson, Colin. 2001. Consonant cluster neutralization and targeted constraints. *Phonology* 18: 147-197.
- Yip, May. 2004. Phonology of the These Language. *Occasional Papers in the Study of Sudanese Languages* 9: 93-117.
- Yip, Moira. 1980. *The Tonal Phonology of Chinese*. Bloomington, IN: Indiana University Linguistics Club.
- Yip, Moira .2002. *Tone*. Cambridge University Press.
- Zimmer, Karl and Barbara Abbott. 1978. The k/Ø alternation in Turkish: Some experimental evidence for its productivity. *Journal of Psycholinguistic Research* 7: 35-46.
- Zoll, Cheryl. 1998. Positional asymmetries and licensing. Manuscript, MIT.