

# UC Berkeley

## UC Berkeley Previously Published Works

### Title

A vertical garden: origins of the Vegetation-Bearing Architectonic Structure and System (1938)

### Permalink

<https://escholarship.org/uc/item/62m5k813>

### Journal

Studies in the history of gardens & designed landscapes, 32(2)

### ISSN

1460-1176

### Author

Hindle, Richard L

### Publication Date

2012-06-01

### DOI

10.1080/14601176.2011.653535

Peer reviewed

This article was downloaded by: [University of Illinois at Urbana-Champaign]

On: 24 April 2012, At: 13:29

Publisher: Routledge

Informa Ltd Registered in England and Wales Registered Number: 1072954 Registered office: Mortimer House, 37-41 Mortimer Street, London W1T 3JH, UK



## Studies in the History of Gardens & Designed Landscapes: An International Quarterly

Publication details, including instructions for authors and subscription information:

<http://www.tandfonline.com/loi/tgah20>

### A vertical garden: origins of the Vegetation-Bearing Architectonic Structure and System (1938)

Richard L. Hindle <sup>a</sup>

<sup>a</sup> University of Illinois Urbana-Champaign

Available online: 24 Apr 2012

To cite this article: Richard L. Hindle (2012): A vertical garden: origins of the Vegetation-Bearing Architectonic Structure and System (1938), Studies in the History of Gardens & Designed Landscapes: An International Quarterly, 32:2, 99-110

To link to this article: <http://dx.doi.org/10.1080/14601176.2011.653535>

PLEASE SCROLL DOWN FOR ARTICLE

Full terms and conditions of use: <http://www.tandfonline.com/page/terms-and-conditions>

This article may be used for research, teaching, and private study purposes. Any substantial or systematic reproduction, redistribution, reselling, loan, sub-licensing, systematic supply, or distribution in any form to anyone is expressly forbidden.

The publisher does not give any warranty express or implied or make any representation that the contents will be complete or accurate or up to date. The accuracy of any instructions, formulae, and drug doses should be independently verified with primary sources. The publisher shall not be liable for any loss, actions, claims, proceedings, demand, or costs or damages whatsoever or howsoever caused arising directly or indirectly in connection with or arising out of the use of this material.

# *A vertical garden: origins of the Vegetation-Bearing Architectonic Structure and System (1938)*

RICHARD L. HINDLE

I guess everyone has crazy brothers and sisters. I know I have. Stan, by the way, has taken out a patent on an invention of his called 'Botanical Bricks', which are simply plant units capable of being built up to any height, for quick landscape effects, the vertical surfaces covered with flowering vines, or the like. He thinks that the idea has great possibilities for such things as world fairs, city yards, indoor gardens, and many other projects. I think perhaps he has got hold of something, and have written him for more information. He certainly deserves a break.

E. B. White, 1937, in a letter to Katherine S. White<sup>1</sup>

## **Introduction**

A garden may be understood as a place where the 'geography of the mind meets that of the earth',<sup>2</sup> making it entirely apropos that the vertical garden finds its origins in the monumentally horizontal prairies and farmlands of the American Middle West, where the topography of Professor Stanley Hart White's creative intellect meets a seemingly endless geography of flatness. White patented the first known green wall in 1938, prototyping the technology in the backyard of his Urbana residence, yet the concept emerges in his writings and drawings as far back as 1931 as a response to the problem of modern garden design. The significance of this invention has 'still unrealized provocations'<sup>3</sup> on the history of gardens and designed landscapes, having been conceived during a trajectory towards modernism in the same geographic region as the Prairie School and American Skyscraper. Although the provenance of this new technological garden is topographically uncanny, the invention itself is pure genius, synthesizing ideas from modern landscape and architectural theory, building sciences,

horticulture, and industrial arts alike. White's vertical garden finds its legal origins in 1937–38, albeit the technological and material precursors to the invention extend back to early horticultural experiments and industrialization of modern building materials.

Stanley Hart White, Professor of Landscape Architecture at the University of Illinois Urbana-Champaign from 1922 to 1959, was granted US Patent 2,113,523 on 5th April 1938 for the *Vegetation-Bearing Architectonic Structure and System* in which he describes the method for creating an 'architectonic structure of any buildable size, shape or height, whose visible or exposed surfaces may present a permanently growing covering of vegetation'.<sup>4</sup> In six beautifully illustrated pages, Professor White reveals the new art of growing plants within/on a vertical, architectonic, substrate-holding frame, and in the process describes a new vertical garden type not fully realized till after his death in 1979. All that remains of White's invention are his careful diaries, a series of patents, and his brother E. B. White's correspondences about Stan's new invention. Stanley Hart White is best known as an educator who modernized landscape pedagogy at the University of Illinois, influencing the work of Hideo Sasaki, Peter Walker, Richard Haag, and others, through his innovative teaching style and creativity.<sup>5</sup> With the discovery of his patent for the first known green wall, or Botanical Bricks, he may also be credited as an inventor and technological innovator, conceptualizing the vertical garden and pioneering green modernism (figure 1).

White's thoughts on vegetation-bearing architecture crystallize in his patent of 1938, yet notions of a green wall emerge as early as 1931 in his lectures and writings on the modern garden. Although the intended audiences for White's

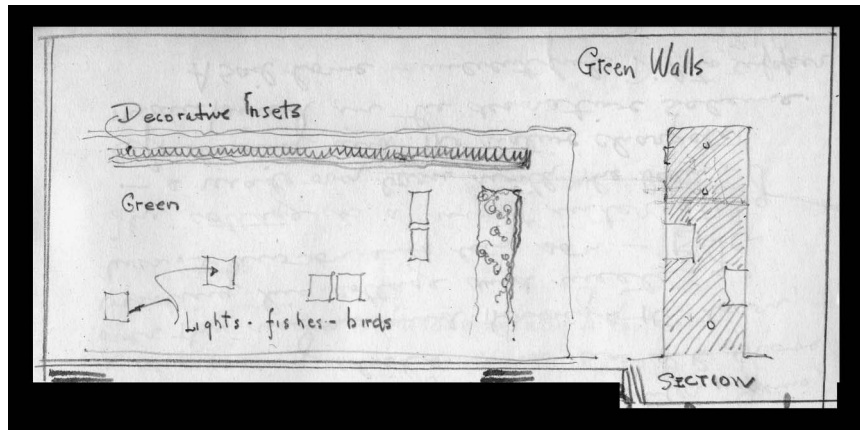

FIGURE 1. First sketch of a 'Green Wall' by Stanley Hart White (1932). Recorded in his *Commonplace Books Index* as an idea for the Century of Progress Exhibition in 1933. Stanley White Papers, Record Series 12/4/23, Box 1, *Commonplace Book Eleven*, Extracted 10 June 1943, University of Illinois Archives.

early writings on vertical greenery are not yet apparent, the idea of a vegetation-bearing garden enclosure preoccupies him for several years as documented in his personal journals, or *Commonplace Books*, in the University of Illinois Library Archives. Technical aspects of White's green wall find their clearest articulation in US Patent 2,113,523, filed on 18th August 1937, yet the theoretical dimensions developed as a treatise on modernism and garden design, in which the vertical surfaces of the garden create a backdrop for modern living.

In an essay titled 'What is Modern', White discusses the green wall as a design solution for the modern garden, allowing for the preservation of a free plan and composition of a garden in the vertical dimension. His references to Walter Gropius, Le Corbusier, Frank Lloyd Wright, Louis Sullivan, Walt Whitman, Charlie Chaplin, Norman Bel Geddes, Adolph Appia, Sheldon Cheney, Walt Disney, and others, situates the work among a group of 'moderns' concerned with changing lives through art and architecture.<sup>6</sup> The *Vegetation-Bearing Architectonic Structure and System* evolved as a response to the problem of modernism in garden design, and is a unique contribution of landscape architecture to this effort, representing a clear translation of garden theory into garden form and legalese. The prescience of this work is astounding, predicting not only the

emergence of the vertical garden in the contemporary built environment, but a method of scholarship in patent development not widely accepted by US universities until the 1970s.<sup>7</sup>

The first drawings of a green wall appear in White's *Commonplace Books* in 1932 (figure 1) as two humble sketches of a wall section and elevation. White's elevation sketch shows a wall composed of vertical greenery, decorative insets, lights, fishes, and birds occupying the inset voids. His section sketch reveals a soil filled wall structured with interior irrigation and voids for compositional elements. Annotations in the *Commonplace Books Index* identify the sketch as an idea for the Century of Progress Exhibition in Chicago, and as his first sketches of Botanical Bricks. White furthers his new idea in an essay on the modern garden, stating:

In the first place there is little reason for introducing extreme decoration into the ground plan. New ideas of living call for such absolute simplicity that if the plan is perfectly plain it may be best in character. Besides, there is something absolute about the ground plan that makes it less susceptible of changes in style than the vertical surfaces and even makes Chinese architecture look like Roman.

In the next place, a vast field of possibility lies open for development, of the walls in a modern garden and it's conceivable that fabricated metal compost filled walls with interior irrigation might be easily devised to produce fine sheets of greenery or color in which the most fanciful imagination of the designer could be expressed in insets of lights, sculpture, or bird cages, fish globes and any other extravagances.<sup>8</sup>

White's experiments in vertical gardening are part academic pursuit, and part rogue backyard experiment outside the bounds of institutional scholarship. Functional prototypes developed in White's potting shed in Urbana, Illinois, were quite successful, and he even managed to sell a single unit to William P. Crane, Professor of Architecture at the University of Syracuse and former Secretary of Housing to President Roosevelt.<sup>9</sup> He writes:

In the back-yard the botanical-brick samples grew into a small wall and became green and attractive, and the visitors were charmed by their novelty! In the garage, a potting shed was fixed up with all the interesting and necessary paraphernalia of gardening. Tests were carefully made and recorded to show the growth of plants and the water content of various cultures. The plants grew lavishly and by August it was possible to tabulate information on the results, including some remarkably satisfactory sums on Bill Kennedy's tin roof over the co-op building.<sup>10</sup>

Although technical records of these original experiments remain elusive, the spirit of discovery permeates White's *Commonplace Books*. His dreams of patents, economic freedom, worlds fairs, and recognition for his invention were only partially realized until dissolution of his most fanciful dreams into preoccupations with wartime efforts. White's journal entries of the period document a radical shift in 1938–40 from his interest in development, marketing, and distribution of botanical bricks, to an emphasis on newspaper clippings and current events. White was not alone, as World War II captured the collective conscience of architecture, design, and society towards new ends and modes of production.<sup>11</sup>

### The new art of vegetation-bearing architecture

White's inchoate drawings and description of a green wall in 1931–32 mature until his application for the *Vegetation-Bearing Architectonic Structure and System* on 18th August 1937, where he artfully translates garden theory into United States Patent and Trademark Office (USPTO) legalese with the help of his attorney, Elmer Hovenden Gates of Arlington, Virginia.<sup>12</sup> The new art of vegetation-bearing architecture was entirely novel at the time of application, and no citations of prior art are associated with White's invention. Currently, thirty-four international patents cite US Patent 2,113,523 as prior art, encoding an array of inventions from grass cube chairs, to vegetation-bearing gabion walls.<sup>13</sup> Interestingly, White's lawyer, Elmer Hovenden Gates, and proposed business partner, William M. McPherson, patented related vegetation-bearing technologies within weeks of his submission. More than 50 patents cite the *Vegetation-Bearing Cellular Structure and System*, *Vegetation-Bearing Display Surface*, and the *Vegetation-Bearing Architectonic Structure and System*, collectively encoding a diverse ensemble of environmental technologies.

The legalese defining this new field offers valuable insights into the founding principles of vegetation-bearing architecture as a chimera of architectonic structure and vegetated system. According to White, architectonics relates to 'the art of landscaping structure as well as to buildings, but distinguished from the art of plant culture'.<sup>14</sup> Within this architectonic structure, plant growth is supported through a layering of horticultural substrates and reticular materials. In this configuration, the 'vegetation in its final positions has its roots within the compost while the tops of the vegetation would extend through the reticular surfaces of the units or compounds into the open air where their normal

development occurs'.<sup>15</sup> The patents legalese describes not only the technical specifications of White's new invention, but also the proposed scope of vegetation-bearing architecture as a new art. This scope is of particular interest with the emergence of the vertical garden and green wall in the contemporary built environment, as the language that defines the new art also encodes innovations in related technologies today. White defines this new technological garden type with the following claims:

This invention is believed to reveal a new art of vegetation-bearing architectonic structure. It comprehends a structural method with its related structural units and compounds. A principal object of this invention is to provide a method for producing an architectonic structure of any buildable size, shape or height, whose visible or exposed surfaces may present a permanently growing covering of vegetation. Another object is to provide a vegetation-bearing structural unit therefore. A further object is to provide such a unit that may be irrigatable, portable and interchangeable. Another object is to provide such a unit of sufficient flexibility to enable it to be bent, curved or warped into various shapes. Another object is to provide such a unit that may be permanently plant-bearing and plant-nourishing. A further object is to provide fixed, flexible or portable architectonic compounds of such units . . .

The underlying principle of the present invention is to provide the architectural profession and related industries with an efficient and inexpensive method and means for utilizing a novel medium for ornamental and useful architectonic construction, in various forms of units and compounds having vegetation-bearing surfaces. For example one purpose of these surfaces may be to build decorative backgrounds or screens for masking eyesores or for concealing people or properties. In such a way as to avoid painted camouflage or the heavy cost of ordinary hedges or camouflage, and to achieve these results, either in a few days, if permanently constructed, or in a few hours or even minutes if built up of the herein described portable units.<sup>16</sup>

White's vision of rapidly assembled and scalable plant-bearing architectonic structures adopts principles from modular building and construction techniques, situating his invention among the array of building products developed during the early decades of the twentieth century. The common name Botanical Bricks further reveals White's notion that his modular building units be integrated into the building arts as commonly as bricks in gardens and architecture. Potential application listed in the patent range from camouflage, concealment, decoration, backgrounds, and screens for use in architectural project (figure 2). Contrasts between White's proposed applications, and contemporary notion

April 5, 1938.

S. H. WHITE

2,113,523

VEGETATION BEARING ARCHITECTONIC STRUCTURE AND SYSTEM

Filed Aug. 18, 1937

3 Sheets-Sheet 1

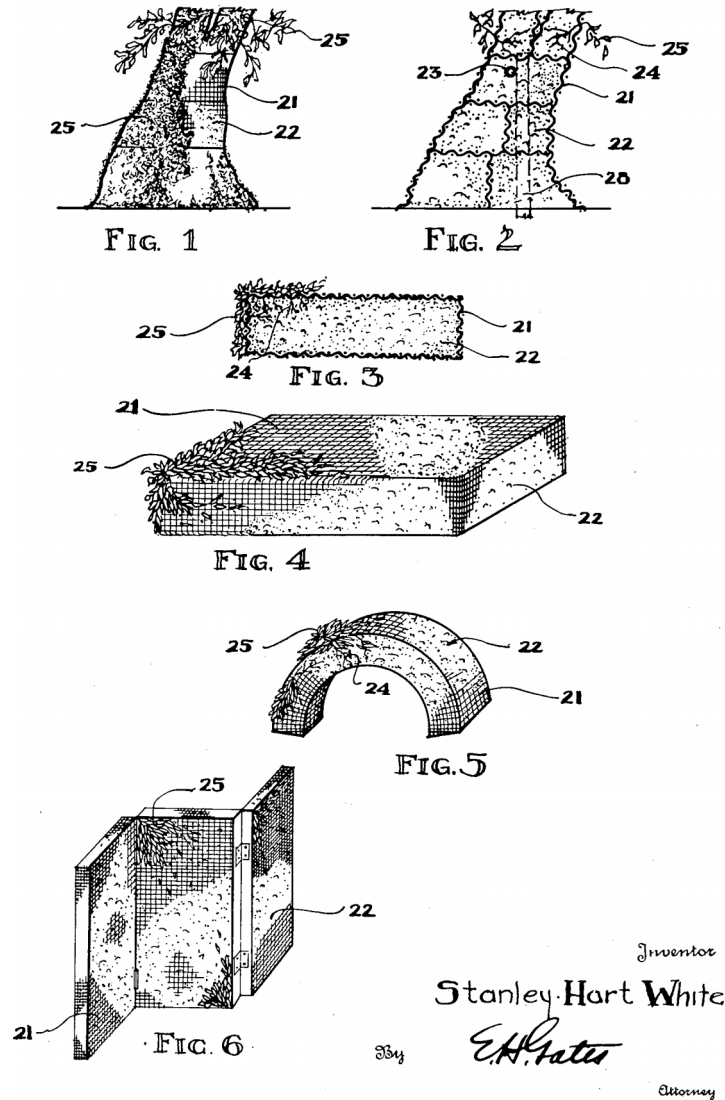

of vegetated architecture as a sustainable technology is especially salient, as language to describe sustainability or environmental performance had not yet been established.

The field of vegetation-bearing architecture was rapidly expanded by two contingent patents filed on 4th April and 28th May 1938 by William M. MacPherson and Elmer Hovendon Gates, respectively. These patents reinterpret the structural system proposed by White in which the vegetation-bearing units assemble like masonry or bricks, and are essentially self-supporting through stacking and repetition (figures 3 and 4). Consecutive to this, patents by Gates and MacPherson envision vegetation-bearing units supported within a structural and load-bearing framework, and vegetation-bearing units secured to a self-supporting wall as a veneer or surface system. Although the structural iterations presented by each patent alter the load-bearing relationship of the vegetation to the structural element, the new art, as described by White, remains remarkably resilient to these adaptations and contemporary permutations.

### The Vegetation-Bearing Cellular Structure and System

Patent application for the Vegetation-Bearing Cellular Structure and System was filed by William M. MacPherson on 4th April 1938, and was granted on 21 June 1938, under the legal guidance of Elmer Hovenden Gates.<sup>17</sup> MacPherson was a graduate of the University of Illinois in architecture and taught at the Lake Forest Academy from 1932 to 1933, where White was the director. After departing Illinois, MacPherson attended Columbia University where he received an Master of Science (MS) in architecture and worked at the USA Housing Authority from 1937 to 1940.<sup>18</sup> Although the exact relationship to White remains unclear, MacPherson is mentioned in White's journals as a potential business partner and collaborator for patent development along with Elmer Hovenden Gates. Irrespective of this dynamic, MacPherson was able to patent a vegetation-bearing technology that adapts the structural system of White's Botanical Bricks to a load-bearing matrix into which the planted units may be inserted (figures 5, 6, 7 and 8). Therefore separating the functions of the Botanical Bricks into units for plant inlay and structural system distinctly. MacPherson Claims:

Skilled workers in the art are aware of prior art disclosures of walls built as masonry construction of various types of vegetation bearing blocks, and are also aware of prior walls of equally well known construction into which are built removable

FIGURE 2. US Patent 2,113,523 Drawing Sheet 1 of 3. Inventor Stanley Hart White.

ORIGINS OF THE VEGETATION-BEARING ARCHITECTONIC STRUCTURE AND SYSTEM

April 5, 1938.

S. H. WHITE

2,113,523

VEGETATION BEARING ARCHITECTONIC STRUCTURE AND SYSTEM

Filed Aug. 18, 1937

3 Sheets-Sheet 2

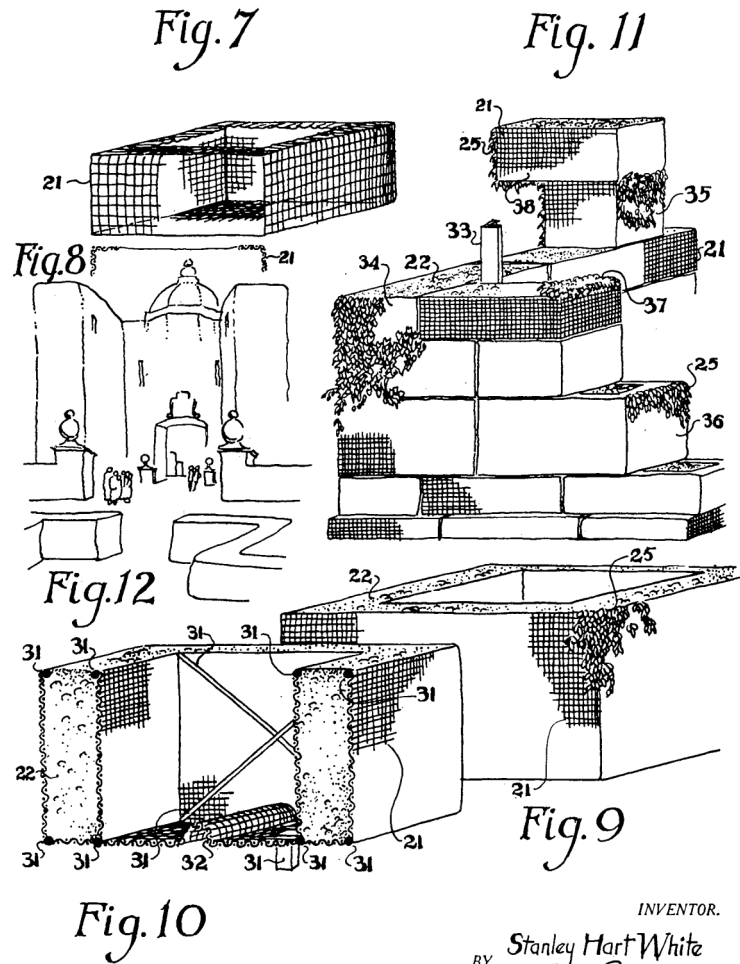

INVENTOR.  
 Stanley Hart White  
 BY *E.H. Prater*  
 ATTORNEY.

FIGURE 3. US Patent 2,113,523 Drawing Sheet 2 of 3. Inventor Stanley Hart White.

April 5, 1938.

S. H. WHITE

2,113,523

VEGETATION BEARING ARCHITECTONIC STRUCTURE AND SYSTEM

Filed Aug. 18, 1937

3 Sheets-Sheet 3

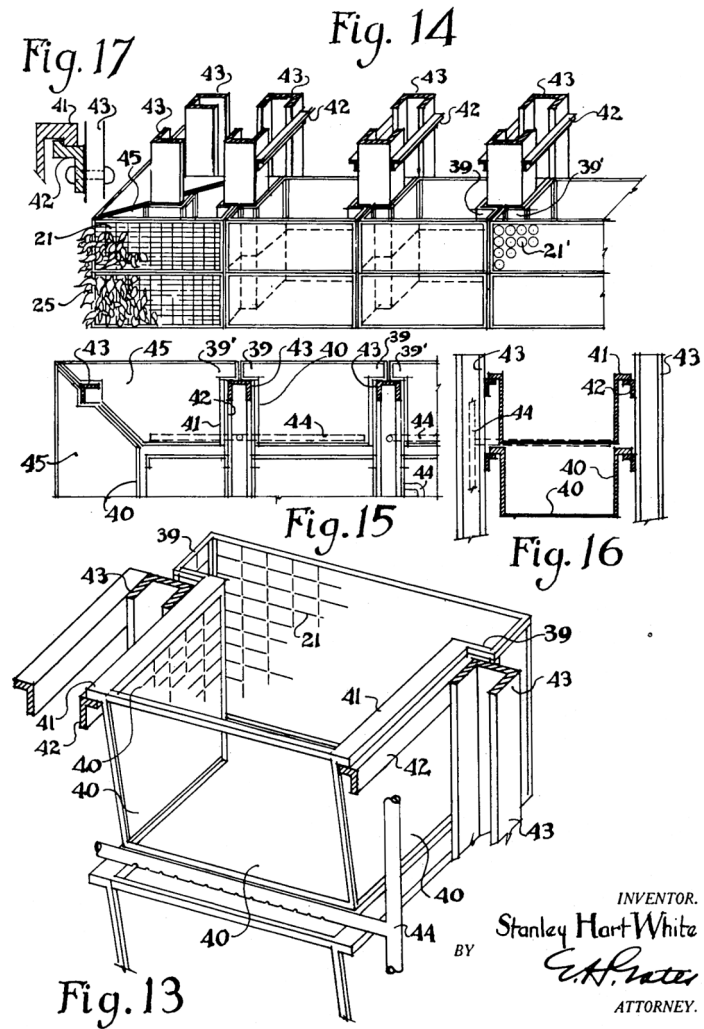

INVENTOR.  
 Stanley Hart White  
 BY *E.H. Prater*  
 ATTORNEY.

FIGURE 4. US Patent 2,113,523 Drawing Sheet 3 of 3. Inventor Stanley Hart White.

June 21, 1938. W. M. MacPHERSON 2,121,173  
 VEGETATION BEARING CELLULAR STRUCTURE AND SYSTEM  
 Filed April 4, 1938 4 Sheets-Sheet 1

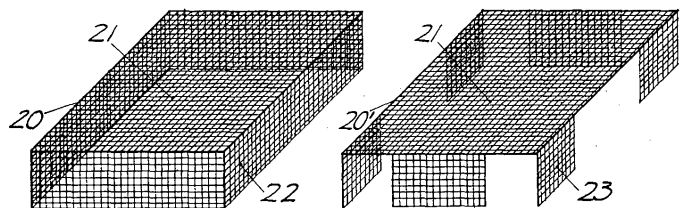

FIG. 1 FIG. 2

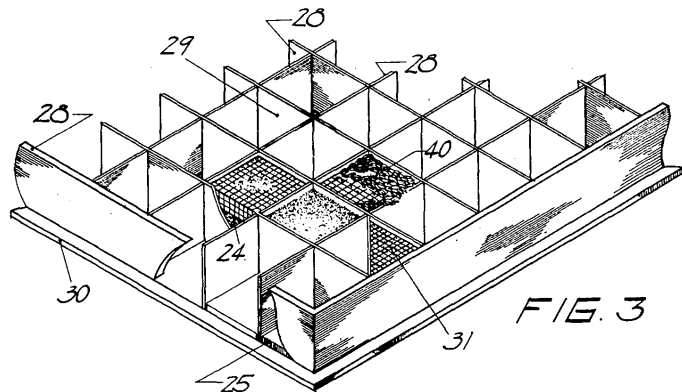

FIG. 3

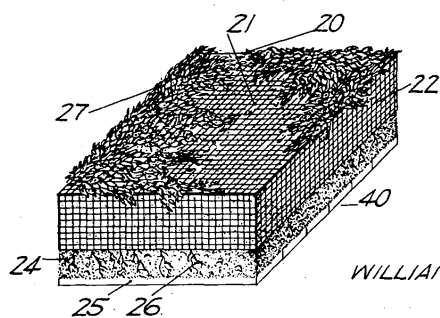

FIG. 4

Inventor  
 WILLIAM M. MACPHERSON.

By *E.H. Pater*

Attorney

June 21, 1938. W. M. MacPHERSON 2,121,173  
 VEGETATION BEARING CELLULAR STRUCTURE AND SYSTEM  
 Filed April 4, 1938 4 Sheets-Sheet 2

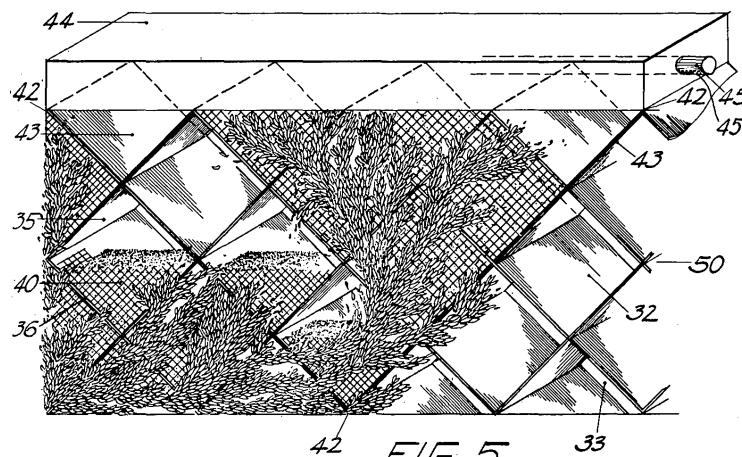

FIG. 5

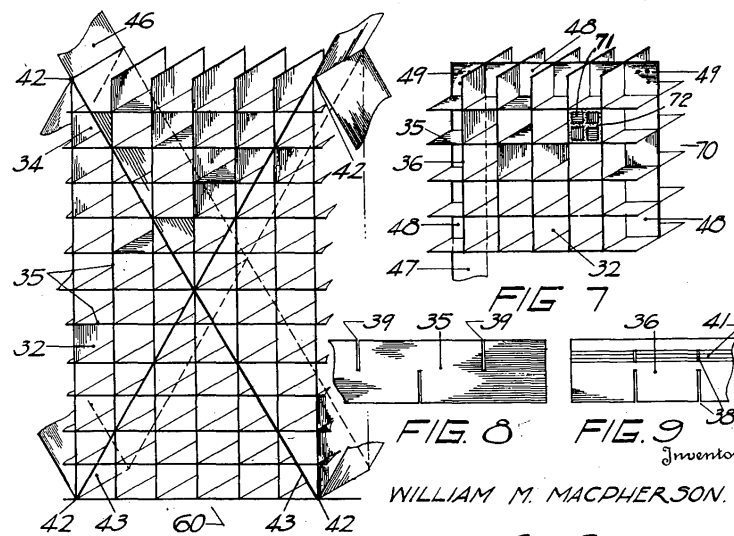

FIG. 6

FIG. 8

FIG. 9

Inventor  
 WILLIAM M. MACPHERSON.

By *E.H. Pater*

Attorney

FIGURE 5. US Patent 2,121,173 Drawing Sheet 1 of 4. Inventor William M. Macpherson.

FIGURE 6. US Patent 2,121,173 Drawing Sheet 2 of 4. Inventor William M. Macpherson.



ORIGINS OF THE VEGETATION-BEARING ARCHITECTONIC STRUCTURE AND SYSTEM

June 21, 1938.

W. M. MacPHERSON

2,121,173

VEGETATION BEARING CELLULAR STRUCTURE AND SYSTEM

Filed April 4, 1938

4 Sheets-Sheet 3

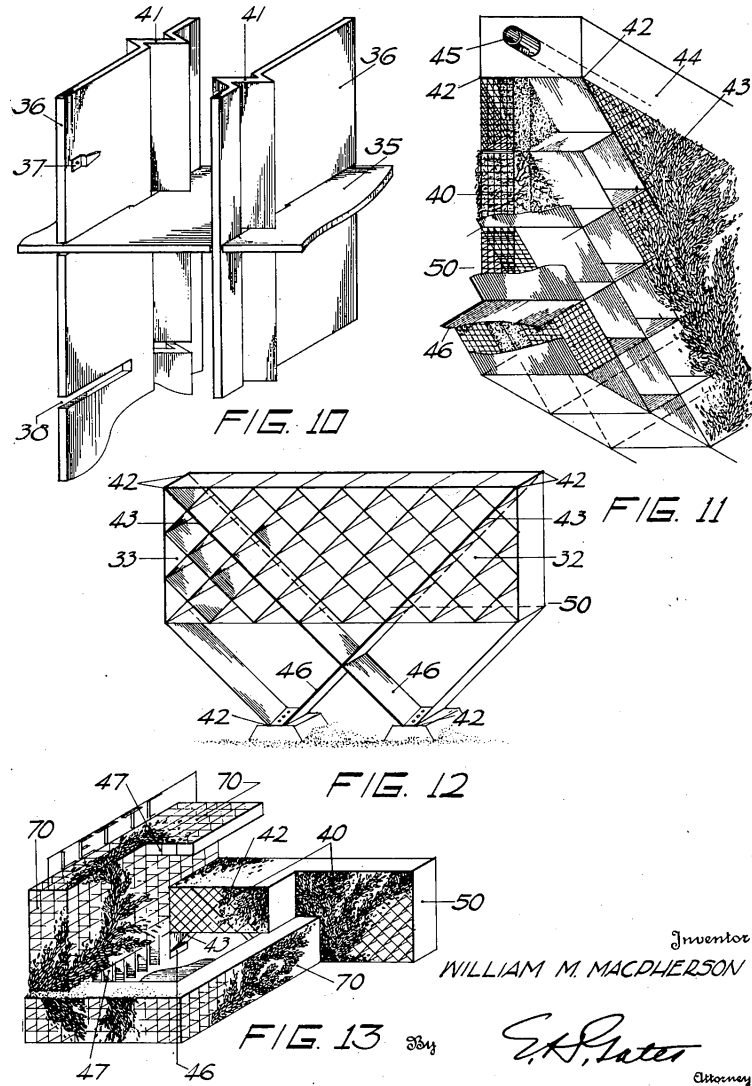

FIGURE 7. US Patent 2,121,173 Drawing Sheet 3 of 4. Inventor William M. Macpherson.

June 21, 1938.

W. M. MacPHERSON

2,121,173

VEGETATION BEARING CELLULAR STRUCTURE AND SYSTEM

Filed April 4, 1938

4 Sheets-Sheet 4

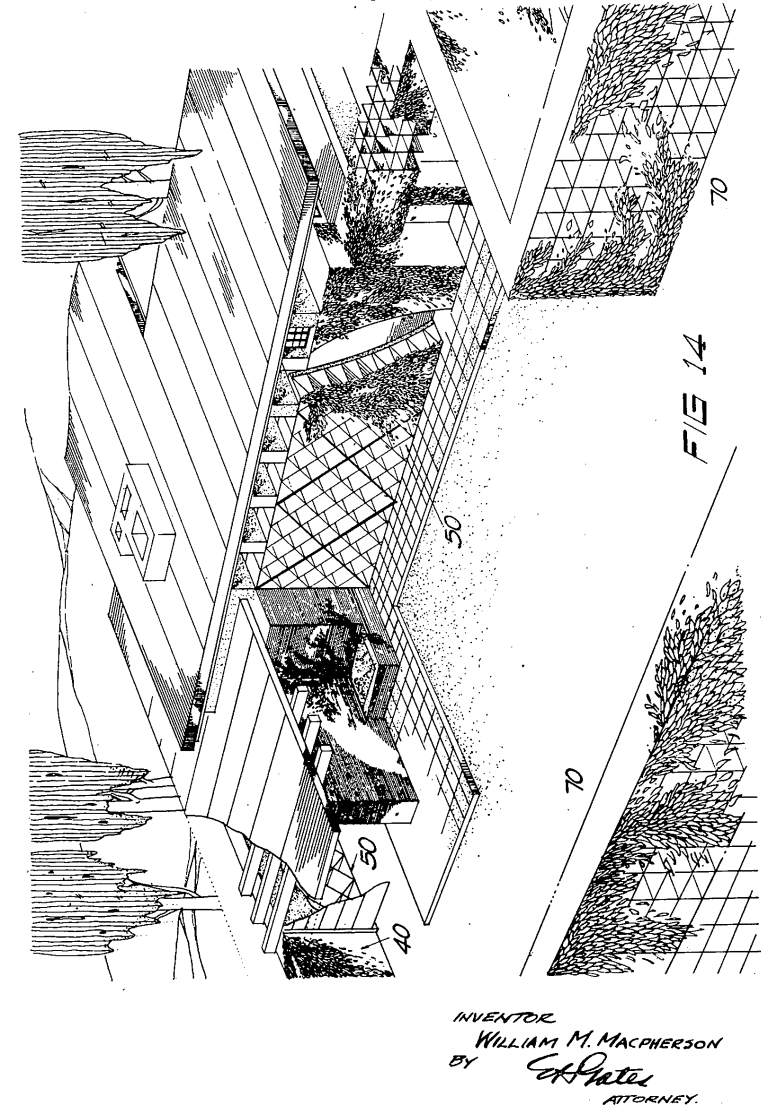

FIGURE 8. US Patent 2,121,173 Drawing Sheet 4 of 4. Inventor William M. Macpherson.

flower pots or flower containers of pottery or other materials, but none of the prior disclosures have ever suggested the dual function performed by the present invention, namely, an integral cellular load bearing plant surface that needs no supporting framework, and that needs no vegetation bearing blocks or structural unit containers to build its greenery surface. The fixed cells are both the wall and the containers in the present invention, which has described herein a novel plant inlay and method for making and embodying it in a novel plant structure. It is thus apparent that the present invention does not require the assembly or incorporation of any removable or non-removable plant container that is a structural unit or that replaces a masonry structural unit. The fixed cells such as 32, 33 and 34 in the present invention perform the combined function of structural unit and container for the plant-compost. The vegetation-bearing surface inlays herein described are relatively fragile or yieldable and, therefore, entirely distinct from structural units, and are not intended to be regarded as structural units herein.<sup>19</sup>

### The Vegetation-Bearing Display Surface and System

Shortly after working with White and MacPherson on patent 2,113,523 and 2,121,173 attorney Elmer Hovenden Gates submitted his own patent for the Vegetation-Bearing Display Surface and System on 27th May 1938, and was granted US patent 2,279,735 on 14th April 1942.<sup>20</sup> Gates' invention once again reinterprets the relationship of structural system to vegetation-bearing unit, proposing a veneer-like system that attaches to a self-supporting wall (figure 9). The basic assembly of the system borrows the plant unit from White and MacPherson, offering a method for attachment to preassembled walls. Gates Claims:

This invention relates to vegetation bearing architectonic structures presenting plant-bearing facing units, and more particularly to upwardly projecting mounting surfaces suitable for indoor and outdoor advertising displays presenting surfaces carpeted with growing flowers and vegetation. It further comprehends the related method of making and assembling such display structures, particularly wherein economy of structure is a factor and wherein ability to distribute unusual loads is not essential. An object of this invention is to afford a vegetation covered display structure that may be rapidly and economically erected and dismantled. Another object is to provide such a structure that may be rapidly re-patterned in a variety of designs and shapes. A further object is to provide a method for making these novel structures and their regular plant facing units. Equally important objects will more plainly appear from the detailed explanation and drawing presented herewith in exemplification but not in limitation of the present invention.<sup>21</sup>

April 14, 1942. E. H. GATES 2,279,735  
 VEGETATION-BEARING DISPLAY SURFACE AND SYSTEM  
 Filed May 27, 1938

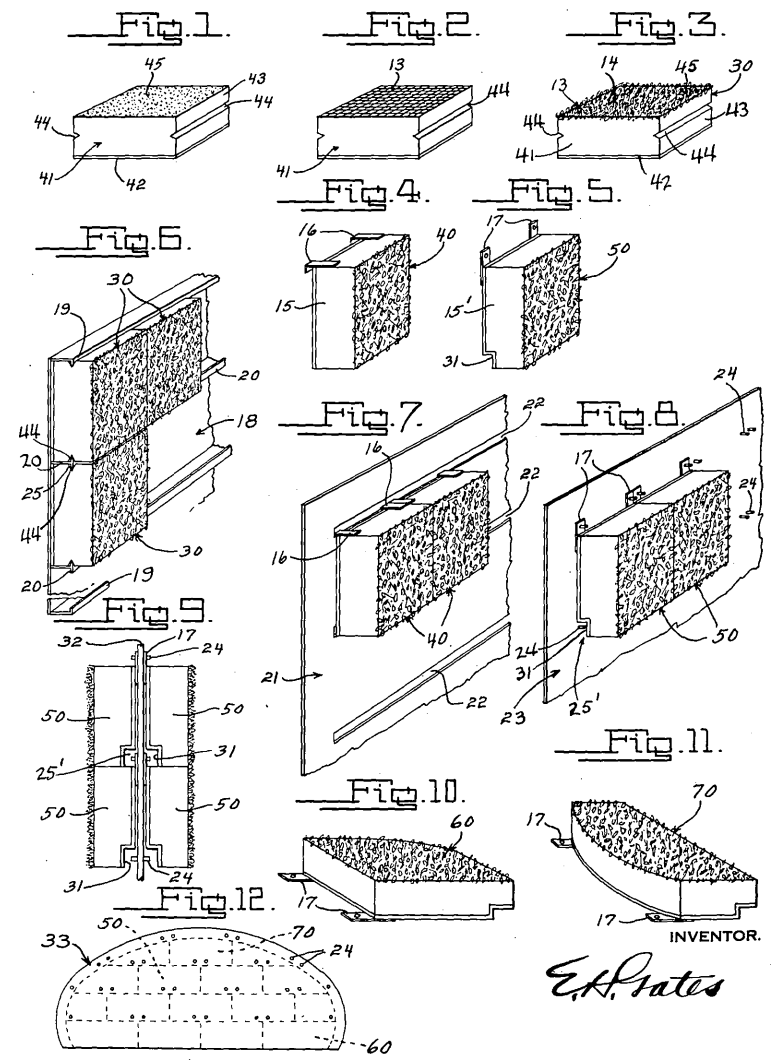

FIGURE 9. US Patent 2,279,735 Drawing Sheet 1 of 1. Inventor Elmer Hovenden Gates.

Downloaded by [University of Illinois at Urbana-Champaign] at 13:29 24 April 2012

### Technological and material dimensions of the new art

Although the structural modifications proposed by Gates and MacPherson reorient the relation of the vegetation-bearing unit to the underlying structural system, the basic technology and principles remains intact. The resilience of White's new art is found in its aptitude for reinterpretation, as he defines a relationship between plants and structure that elucidates their interdependence and interstices. Triangulations between the building sciences, horticultural arts, and landscape theory are seminal to White's conception of the Vegetation-Bearing Architectonic Structure and System. White received a Bachelor of Science (BS) in agriculture from Cornell in 1912, his Master of Landscape Architecture (MLA) from Harvard in 1915.<sup>22</sup> His background in science and design undoubtedly contributed to a synthetic approach to plants, structure, and garden form, yet it is a convergence of material innovations and new scientific discoveries that make the vertical garden possible, and timely, in the 1930s.

Innovation in building materials occurred rapidly in early years of the twentieth century, as industrialization and wartime research fueled experiments in architecture and the sciences alike. Material Sciences flourished during World War I and material product lines expanded through the roaring twenties, radically impacting architecture and the production of buildings.<sup>23</sup> New building materials were readily tested, and exhaustive volumes of literature were published to disseminate information in an ever-changing marketplace for architects and designers. Building material bibliographies from the era document rapid integration and research on materials such as armorphy, clay tile, plywood, glass block, masonite, rostone, vinylite, celotex, porcelain, zonolite, to name just a few.<sup>24</sup> Concurrent to the expansion of new materials in architecture, was an expansion of the role of popular science and a belief that technology would improve modern living. In agriculture, new technologies such as hydroponics, popularized in the 1930s, promised to create new productive systems that would increase yields and feed a growing population with increased efficiency.

White's invention exists at the intersection of these spheres of innovation, where the differentiation between horticultural system and building system begins to blur. Efforts towards new and efficient forms of building assembly paralleled new and efficient forms of agriculture. White hybridized these elements, stating:

The essential idea therefore is to avoid planting the growing material in the open ground or in ordinary pottery containers or boxes which are heavy and

cumbersome and to provide instead (a) a wall enclosed by reticular material supported by reinforcing members (b) a wall or compound built up of units of reticular material so that the structure would stand like a dry wall of masonry, or (c) a wall or compound built of interfitting portable and replaceable reticular units in a skeleton supporting frame designed to control the shape and dimensions of the completed compound.<sup>25</sup>

White envisioned that Botanical Bricks would stack like masonry through the reinforcement of the reticular meshes and enclosing the plant growing substrate. Where weight reduction is required, he suggests that a:

constituent of the compost may comprise a process, aerated or 'puffed' micaceous material such as vermiculite, that is at present marketed under the trade name of Zonolite. The various plant nutrients and conditioners mentioned herein as well as other varieties available on the market may be mixed with the compost before it is introduced into the structure or it may be injected into the compost through the reticular material or it may be pumped into the structure through the irrigating means herein described.<sup>26</sup>

White also suggests that the substrate may be entirely inert through the use of building insulation as a growth substrate, proposing that the 'soil substitute or compost for vegetation growth may be made with any of the mineral fibers used for insulating purposes or any other suitable substance of low specific gravity to take the place of the relatively inert mineral soil particles of natural earth'.<sup>27</sup> The integration of inert substrates into Botanical Bricks establishes a direct correlation between vegetation-bearing architecture and the science of hydroponics, or soilless culture. Interestingly, it appears that White actually predicted the use of mineral wool in hydroponics, as the material was not fully integrated as a growth medium until the late 1960s when Grodan Rockwool<sup>®</sup> first became commercially available.<sup>28</sup> Experimentation with growth substrates has continued in the field of hydroponics to include inorganic materials such as vermiculite, mineral wool, expanded clay, polyurethane, polystyrene, polyester fleece, and zeolite, continuing to expand the role of building materials in plant growth systems.<sup>29</sup>

White's knowledge of hydroponics, or aquiculture as it was previously known, is clearly articulated in the patent of 1938 through discussions of chemical requirements for plant growth in artificial substrates. Divisions between substrate and nutriment allowed White to speculate about the use of inert and lightweight substrates in his Botanical Bricks, but these unnatural

divisions between native soil and inert substrate should be credited to pioneering work of William F. Gericke, founder of modern hydroponics, who laid the conceptual foundation for White to build upon. White describes his modified hydroponic system as follows:

To this may be added humus of any standard or modified form and the chemical nutrients required for plant growth. In addition to which may be mixed or injected into the compost any of the conditioners of organic growth whether chemical (organic or inorganic) bacteriological, symbiotic, enzymatic, hormonal, or in any other way conducive to plant growth and development . . . The various plant nutrients and conditioners mentioned herein as well as other varieties available on the market may be mixed with the compost before it is introduced into the structure or it may be injected into the compost through the reticular material or it may be pumped into the structure through the irrigating means herein described.<sup>30</sup>

White distinguishes between the cultivation of plants in open soil, containers, and within his new architectonic framework. Distinctions between native and artificial soil is particularly timely as the work of William F. Gericke was widely published from 1922 to 1940. Gericke's innovation in water-culture experiments radically altered preconceptions about the relation of plants to the earth, liberating them from parent soil and allowing their roots to interact with new architecture and chemical nutriment. His argument for the adoption of the term hydroponics clearly articulates these distinctions between land-based cultivation and new technological forms, he states:

Hydroponics has analogy in geonics — the Greek term by which agriculture was known for several centuries in the middle ages; this word appears to have been in common use before the Latinized term 'agri-culture' obtained universal standing. Furthermore, 'hydroponics' (hydro, water, and ponos, labor) has a strong economic and utilitarian connotation; therefore it is desirable in view of the historic use of water culture in plant physiology. The word has not been used heretofore in a scientific sense, and hence there can be no objection as to prior usage.<sup>31</sup>

Gericke's division between land-based agriculture and water culture challenges prior concepts of soil or 'compost', and in his 1938 article 'What is Soil' the use of hydroponic substrates such as pebble, cinder, and sand is discussed, further expanding the dialogue on substrate and nutriment.<sup>32</sup>

Although images of Gericke's original experiments were not widely distributed until publication of *The Complete Guide to Soilless Gardening* in 1940, descriptions of water-culture experiments were disseminated in the journal *Science* in 1922, and undoubtedly influenced White's design for Botanical Bricks. Gericke describes a system where:

Rolls (3 × 36 ft) of bituminous roofing paper were unfolded on level ground, and 6 inches of each end and side turned upward to make a reservoir 2 ft. wide, 35 ft. long, 6 inches deep. Wire netting was stretched over the top of reservoir, and burlap on it held the seedbed, which was a layer of sand one half inch deep, but other materials may be used. The reservoir was filled with water and supplied with a number of cartridges which contained the elements required for growth of plants in water.<sup>33</sup>

The layering of wire mesh, burlap, and asphalt paper encapsulates the hydroponics substrate and supports plant growth, creating a system detached from native soil through the use of layered building materials. White furthers these developments by adapting Gericke's original system to operate vertically. He proposes that the horticultural substrate be retained by material include wire fabric sheets, expanded metal, and meshed chain mail fabric, perforated plastic sheets, reinforced by structural members to accommodate load-bearing capacity. Gericke's experiments were a liberating force, allowing for further separation between plants and soils, and the advancement of new possible relations between plants and structure. Although the substrate used for Gericke's original experiment was limited to sand, further trials included gravel, sand, cinders and new construction materials such as Gravelite<sup>®</sup>, which found use as a lightweight aggregate in construction in and hydroponics experiments simultaneously.<sup>34</sup> By the time Gericke's research reached the general public in 1940, Stanley White's patent was already granted, yet both innovators predicted the evolution of plant growth away from native soil, towards a fecund interdependence with technology, structure, and new materials.

## Conclusion

Innovation in the field of vegetation-bearing architecture is defined by the union of horticultural and building systems into a new synthetic whole through which one may build and cultivate simultaneously. The scope of this field is

defined through the innovations in structures and horticulture presented by the *Vegetation-Bearing Architectonic Structure and System*, *Vegetation-Bearing Cellular Structure and System*, and the *Vegetation-Bearing Display Surface and System*, which collectively outline the field of vegetation-bearing architecture. This body of work finds its origins in the writings and drawings of Professor Stanley Hart White at the University of Illinois, who theorized the vertical garden as a backdrop for modern living, and a technology for mass production in the machine age.

Notions of verdant modernism are not discreet to the work of Stanley Hart White. Walter Gropius envisioned a city where:

The utilization of flat roofs as 'grounds' offers us a means of re-acclimatizing nature amidst the stony deserts of our great towns; for the plots from which she has been evicted to make room for buildings can be given back to her up aloft. Seen from the skies, the leafy house-tops of the cities of the future will look like endless chains of hanging gardens.<sup>35</sup>

Sadly, Gropius' and White's visions of horizontal and vertical verdure have only recently converged, yet contemporary progress towards an ecological urbanism promises to catalyze new and innovative forms of vegetation-bearing architecture.

The dynamic relationship between plants and structure is not new, having been investigated at least since the time of Pliny the Elder (23–79 BC), when thin sheets of talc arranged on frames were used to shelter

delicate crops, thereby increasing yields.<sup>36</sup> Permutations of that experiment evolved since antiquity, promoting innovation in architecture, horticulture, and related fields in the arts and sciences. In architecture, for example, the structural systems of early greenhouses are well-documented precursors for the use of glass in modern architecture, initiating a revolution in construction technology and the production of space.<sup>37</sup> Although divisions between disciplines has effectively parsed the pure study of plants and structure, the dynamism persists and continues to emerge in new and interesting forms such as the structural grafts articulated by the Baubotanic at the University of Stuttgart,<sup>38</sup> and the tensile structures that suspend vegetation-bearing units at the 'Lost in Paris' house by R. & Sie Architects.<sup>39</sup> The trajectory of vegetation-bearing architecture from botanical brick, to cellular structure, to veneer as articulated by White, MacPherson, and Gates is indicative of innovations occurring in the field today, and is reminiscent of the transformations in building technology from the stereotomic to the tectonic as described by Kenneth Frampton, Gottfried Semper and others.<sup>40</sup> This transformation is ongoing, establishing a valuable historical context for contemporary vegetation-bearing architectonic structures 'of any buildable size, shape or height, whose visible or exposed surfaces may present a permanently growing covering of vegetation'.<sup>41</sup>

*University of Illinois Urbana-Champaign*

#### NOTES

1. E. B. White and Dorothy Loblano Guth, *Letters of E. B. White* (New York: Harper & Row, 1976), p. 151.
2. Sébastien Marot, *Sub-urbanism and the Art of Memory* (London: Architectural Association, 2003), p. 20.
3. Stanley Hart White, *Stanley Hart White Papers*, Record Series 12/4/23, Box 1, Commonplace Book Eleven, University of Illinois Archives. See "Further references and notes" below.
4. Stanley Hart White, *Vegetation-Bearing Architectonic Structure and System* (USA: US Patent 2,113,523, 1938), p. 4, lines 6–9.
5. Peter Walker and Melanie Louise Simo, *Invisible Gardens: The Search for Modernism in the American Landscape* (Cambridge, MA: MIT Press, 1994), pp. 201–224.
6. Stanley Hart White, Unpublished manuscript/lecture notes (5 March 1931). University of Illinois Urbana-Champaign.
7. David C. Mowery and Bhaven N. Sampat, 'University patents and patent policy debates in the USA, 1925–1980', *Industrial & Corporate Change*, 10/3, 2001, pp. 781–814.
8. Stanley Hart White, 'What is modern'. Unpublished manuscript (c. 1931–1932). University of Illinois Urbana-Champaign.
9. [http://archives.syr.edu/collections/faculty/crane\\_bio.html](http://archives.syr.edu/collections/faculty/crane_bio.html).
10. Stanley Hart White, *Stanley Hart White Papers*. Record Series 12/4/23, Commonplace Books fifteen. University of Illinois Archives.
11. Jean-Louis Cohen, *Architecture in Uniform: Designing and Building for the Second World War* (Montréal: Canadian Centre For Architecture, 2011), pp. 251–279.

12. Stanley Hart White, Vegetation-Bearing Architectonic Structure and System (USA: US Patent 2,113,523, 1938).
13. [http://worldwide.espacenet.com/quickSearch?locale=en\\_EP](http://worldwide.espacenet.com/quickSearch?locale=en_EP).
14. Stanley Hart White, Vegetation-Bearing Architectonic Structure and System (USA: US Patent 2,113,523, 1938), p. 6, lines 48–50.
15. Stanley Hart White, Vegetation-Bearing Architectonic Structure and System (USA: US Patent 2,113,523, 1938), p. 5, lines 18–23.
16. Stanley Hart White, Vegetation-Bearing Architectonic Structure and System (USA: US Patent 2,113,523, 1938), p. 5, lines 1–20, 58–67.
17. William M. MacPherson, Vegetation-Bearing Cellular Structure and System (USA: US Patent 2,121,973, 1938), p. 5, lines 1–25.
18. <http://communities.aia.org/sites/hdoaa/wiki/AIA%20scans/M-P/MacPhersonWilliamM.pdf>.
19. William M. MacPherson, Vegetation-Bearing Cellular Structure and System (USA: US Patent 2,121,973, 1938), p. 5, lines 1–22.
20. Elmer Hovenden Gates, Vegetation-Bearing Display Surface and System (USA: US Patent 2,279,735, 1942).
21. Elmer Hovenden Gates, Vegetation-Bearing Display Surface and System (USA: US Patent 2,279,735, 1942), p. 2, lines 1–23.
22. Lillian Hoddeson and Richard Herman, eds, *No Boundaries: University of Illinois Vignettes* (Urbana: University of Illinois Press, 2004), pp. 113–123.
23. Thomas C. Jester, ed., *Twentieth-century Building Materials: History and Conservation* (New York: McGraw-Hill, 1995), pp. 34–43.
24. *Bibliography on New Building Materials* (Washington, 1935).
25. Stanley Hart White, Vegetation-Bearing Architectonic Structure and System (USA: US Patent 2,113,523, 1938), p. 4, lines 29–40.
26. Stanley Hart White, Vegetation-Bearing Architectonic Structure and System (USA: US Patent 2,113,523, 1938), p. 6, lines 31–44.
27. Stanley Hart White, Vegetation-Bearing Architectonic Structure and System (USA: US Patent 2,113,523, 1938), p. 1, lines 48–54.
28. <http://www.grodan.com/about+grodan/history>.
29. Michael Raviv and Johann Heinrich Lieth, *Soilless Culture: Theory and Practice* (Amsterdam and Boston: Elsevier Science, 2008), pp. 459–543.
30. Stanley Hart White, Vegetation-Bearing Architectonic Structure and System (USA: US Patent 2,113,523, 1938), p. 2, lines 1–7, and p. 6, lines 36–44.
31. William Frederick Gericke, ‘Hydroponics-crop production in liquid culture media’, *Science*, 85/2198, 1937, pp. 177–178.
32. William Frederick Gericke, ‘What is soil?’ *Science*, 88/2294, 1938, pp. 568–569.
33. William Frederick Gericke, ‘Water culture experimentation’, *Science*, 56/1450, 1922, pp. 421–422.
34. William Frederick Gericke, *The Complete Guide to Soilless Gardening* (New York: Prentice-Hall, 1940).
35. Walter Gropius and Philip Morton Shand, 1888 transl., *The New Architecture and the Bauhaus* (London: Faber & Faber, 1935), p. 24.
36. John Hix, *The Glass House* (Cambridge, MA: MIT Press, 1974), pp. 9–18.
37. Brent Richards and Dennis Gilbert, *New Glass Architecture* (New Haven, CT: Yale University Press, 2006), p. 6.
38. <http://www.new-territories.com/lostinparis.htm>.
39. <http://www.baubotanik.de/>.
40. Kenneth Frampton and John Cava, *Studies in Tectonic Culture: The Poetics of Construction in Nineteenth and Twentieth Century Architecture* (Cambridge, MA: MIT Press, 1995), pp. 1–27.
41. Stanley Hart White, Vegetation-Bearing Architectonic Structure and System (USA: US Patent 2,113,523, 1938), p. 1, lines 6–9.
42. The subject of vertical gardening and vegetation-bearing architecture is expanding rapidly through internet sources and in print. Recent books on the subject effectively document the proliferation of built projects, yet questions of history, theory, and technology remain largely unresolved in peer reviewed literature and elsewhere, creating fertile ground for future enquiry. The following references, not cited in the main text, provide an overview of this emerging field.
43. Blanc, Patrick, and Véronique Lalot. *The Vertical Garden: From Nature to the City*. New York: W.W.Norton, 2008.
44. Balmori, Diana, and Joel Sanders. *Groundwork: Between Landscape and Architecture*. New York: Monacelli Press, 2001.
45. Uffelen, Chris van. *Facade Greenery: Contemporary Landscapes*. Germany: Braun Publishing AG, 2011.
46. Lambertini, Anna, and Mario Ciampi. *Vertical Gardens: Bringing the City to Life*. London: Thames & Hudson, 2007.