

# Lawrence Berkeley National Laboratory

## Recent Work

### Title

A FAST-CLOSING VACUUM VALVE FOR THE BERKELEY SUPERHILAC

### Permalink

<https://escholarship.org/uc/item/62d6b7tw>

### Authors

Behrsing, G.U.  
Hinkson, J.

### Publication Date

1981-06-01



# Lawrence Berkeley Laboratory

UNIVERSITY OF CALIFORNIA

## Engineering & Technical Services Division

Submitted to Nuclear Instruments and Methods

A FAST-CLOSING VACUUM VALVE FOR THE  
BERKELEY SUPERHILAC

G.U. Behrsing and J. Hinkson

June 1981

RECEIVED  
LAWRENCE  
BERKELEY LABORATORY  
AUG 6 1981  
LIBRARY  
DOCUMENTS

**TWO-WEEK LOAN COPY**  
This is a Library Circulating Copy  
which may be borrowed for two weeks.  
For a personal retention copy, call  
Tech. Info. Division, Ext. 6782

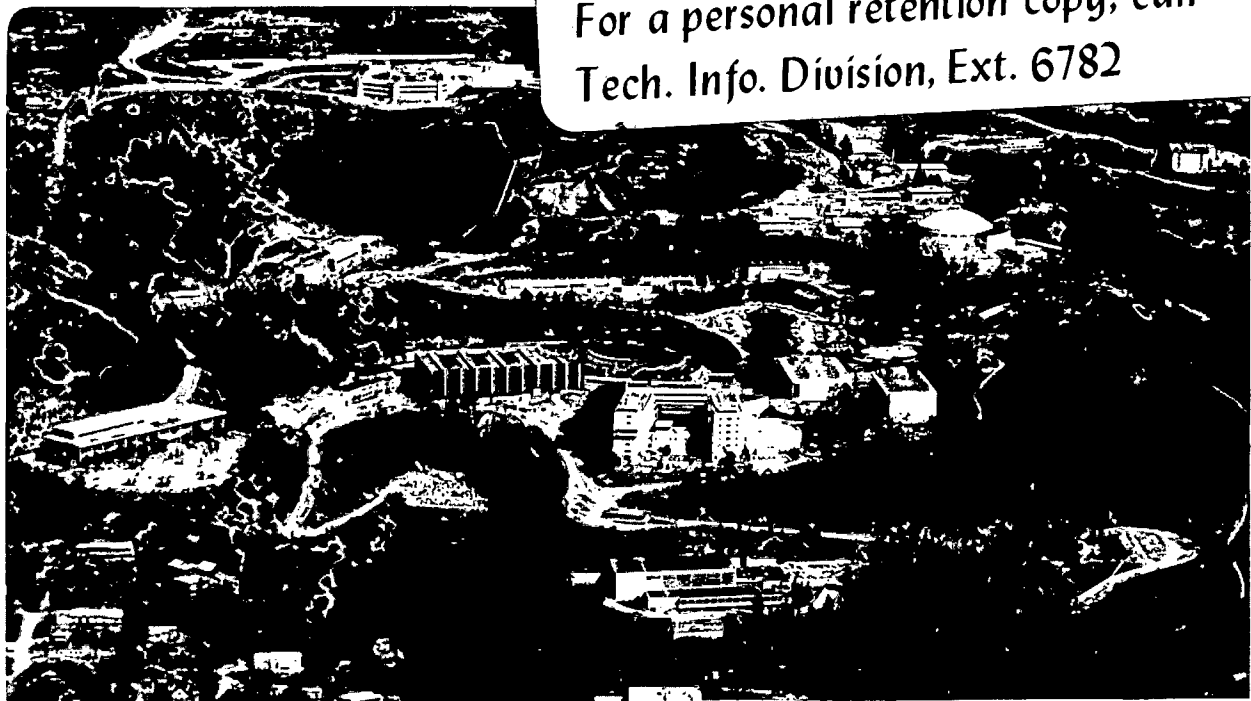

*82*

*LBL-13025  
c.2*

## **DISCLAIMER**

This document was prepared as an account of work sponsored by the United States Government. While this document is believed to contain correct information, neither the United States Government nor any agency thereof, nor the Regents of the University of California, nor any of their employees, makes any warranty, express or implied, or assumes any legal responsibility for the accuracy, completeness, or usefulness of any information, apparatus, product, or process disclosed, or represents that its use would not infringe privately owned rights. Reference herein to any specific commercial product, process, or service by its trade name, trademark, manufacturer, or otherwise, does not necessarily constitute or imply its endorsement, recommendation, or favoring by the United States Government or any agency thereof, or the Regents of the University of California. The views and opinions of authors expressed herein do not necessarily state or reflect those of the United States Government or any agency thereof or the Regents of the University of California.

A FAST-CLOSING VACUUM VALVE FOR THE BERKELEY SUPERHILAC

G. U. BEHSING AND J. HINKSON

LAWRENCE BERKELEY LABORATORY

UNIVERSITY OF CALIFORNIA

BERKELEY, CALIFORNIA 94720

JUNE 1981

ABSTRACT

A larger fast-closing vacuum valve has been built to protect the Berkeley SuperHilac against radioactive contamination during bombardments of highly radioactive targets with heavy ion beams. The valve has a 3.8 cm diameter through-hole and can be vacuum sealed in less than 4 milliseconds by means of a wedge-shaped Teflon gate which is moved into the closed position by the gas pressure from an explosive cartridge. This explosive charge is triggered by the electronic signal from a nude ion gauge at  $10^{-5}$  torr. The fast modified ion gauge power supply will trip the vacuum valve at a rate of pressure rise of 100-1000 dec/sec which should prevent any misfirings on slow pressure rise.

This work was supported by the Director, Office of Energy Research, Office of High Energy and Nuclear Physics, Division of High Energy Physics of the U.S. Department of Energy under Contract No. W-7405-ENG-48.

## 1. INTRODUCTION

Some time ago the development of a fast-acting vacuum valve was reported which was designed to protect the Berkeley 88-Inch Cyclotron from contamination due to the possible rupture of radioactive targets<sup>1</sup>. At the SuperHilac the highly radioactive transuranium targets are mounted on thin foils which are placed under considerable thermal and mechanical stress due to the heavy ion bombardment beam and the inert cooling gas blowing against the foil window. In case of foil rupture the sonic expansion of the target cooling gas would carry the radioactivity into the linear accelerator and result in costly decontamination procedures and down-time.

A larger fast-closing vacuum valve has been built to accommodate the larger beam size at the SuperHilac and to protect the linear accelerator from radioactive contamination. The valve consists of a hardened steel body with a light replaceable Teflon gate which is moved into the closed position by the gas pressure from a commercial explosive cartridge<sup>2</sup>. A fast modified ion gauge circuit has been developed for triggering the valve. Re-arming time for this valve after firing is approximately 20 minutes.

## 2. MECHANICAL DESIGN

A cross-section of the valve is shown in Figure 1. The valve body and the top and bottom lids are constructed of hardened 4140 steel. The wedge-shaped Teflon gate has a 5% taper, the same taper as was cut on the slot in the valve body by electron discharge machining technique. A copper grounding strip is mounted on the leading edge of the gate which makes contact with two spring-loaded wire points in the bottom lid to indicate the closed position of the valve. Experimentation determined the need for spring-loaded contact points since rigid ones were flattened after only a few firings.

The top lid contains mounting holes for two explosive cartridges, Horex Part No. 7728 with a maincharge of 500 mg of No. 51 pistol powder with very fast-burning characteristics. Since the explosion chamber is normally at atmospheric pressure and the Teflon gate is not designed for vacuum sealing in the valve-open position, a 2 mil aluminum foil with O-rings on either side provides the vacuum seal between the valve body and the top lid. After firing, the Teflon gate will always make a vacuum tight seal in the valve-closed position because of the compression of the plastic wedge in the slot.

Re-arming the valve after each firing is relatively simple and fast. The valve unit can be disassembled in the beam line, the powder traces and Teflon shavings cleaned out, and the gate, vacuum foil and explosive cartridges replaced on assembly.

### 3. ELECTRICAL DESIGN

Figure 2 shows a block diagram of the fast-closing valve installation. Three Granville-Phillips Model 270 ion gauge controllers connected to nude ion gauges provide pressure signals to the valve firing electronics. For redundancy, two ion gauges, IG1 and IG2 are positioned close to the radioactive target to minimize response time to a pressure burst. A third ion gauge, IG3, is positioned upstream of the fast-closing valve and the vacuum gate valve. The gate valve may be opened to permit beam on the target if the fast-closing valve firing circuits are armed and the pressure differential across the gate valve is small. If a significantly high-pressure difference existed across the gate valve, opening it could cause a pressure burst which would fire the fast-closing valve. Slow pressure rises due to small leaks or defective pumps cause the gate valve to close and the fast-closing valve to disarm. Fast pressure rises sensed by IG1 and IG2 are assumed to be caused by a ruptured target and cause the fast-closing valve to be shut. Although it is very important for the fast-closing valve to protect the Super HILAC beam line from radioactive target debris, the valve should not close unnecessarily because of the time required for valve rearming and target inspection.

A simplified block diagram of the valve firing system is shown in Figure 3. The ion gauge controllers were modified to improve their response time to fast pressure rises. Pressure signals from IG1 and IG2 are amplified and differentiated. The outputs of the differentiators drive comparators with thresholds set to voltage commensurate with about 300 decades per second pressure rise. If IG1 or IG2 senses a rapid pressure rise, the SCR switches are closed, discharging the capacitors and firing the explosive charges of the valve. Valve closure is indicated by a lamp on the valve electronics chassis.

#### 4. TESTS

The performance of the fast-closing valve was tested to determine its closing speed and the pressure buildup in the explosion chamber. A piezoelectric transducer system<sup>3</sup> measured a 2000 psi dynamic pressure pulse when two explosive cartridges were fired simultaneously. With this charge the valve closed in 3-4 milliseconds. When only one cartridge was fired the closing time of the valve increased to 5-6 milliseconds while the maximum pressure in the chamber was approximately 1000 psi. The valve closing times included a 1 millisecond response time between the initiating electrical signal and the actual firing of the cartridges as shown by the start of the pressure rise.

The Model 101A02 quartz pressure transducer used in these tests has a resolution of .2 psi and a rise time of 1  $\mu$ sec. Black vinyl electricians tape served as an effective ablative material on the face of the transducer to protect it from the high flash temperature of the explosive charge. Model 482A line power supply was used to couple the self-amplifying pressure transducer to a dual trace storage oscilloscope. Figure 4 shows the two signal traces indicating the valve closing time and the explosive pressure in the chamber.

The response of the fast-closing valve was also checked under actual operating conditions in an experimental beam line. A 27 cm diameter scatter chamber with two 6 cm diameter beam pipe sections was set up with a 2.5 cm diameter aluminum vacuum foil at the end of the downstream pipe and a helium mass analyzer at the end of the upstream pipe. The fast-closing valve was position 7 feet upstream from the foil. An ion gauge was installed next to the aluminum foil to be used as the valve trigger.

After the beam line was evacuated to the  $10^{-5}$  torr range the vacuum foil was punctured by a small copper tube which was connected to a helium cylinder and had a moderate flow of helium gas passing through it. The time zero signal for the test was initiated by the electrical contact between the tube and the foil. The valve closed reliably in less than 4 milliseconds during all tests as shown on the oscilloscope. No helium gas was detected by the mass analyzer indicating that the closing speed of the valve was sufficiently fast to stop the helium gas from passing through and that the Teflon gate was vacuum tight in the closed position.



5. OPERATIONAL SYSTEM

Extensive interlocking is used to guarantee reliable fast-closing valve firing and to avoid any unnecessary firing. Before the valve may be armed, the ion gauge controllers must be operating and be in the correct range. All cables must be correctly connected. Power supplies for linear and digital electronics must be at correct voltages. The firing pulse generator must be operating. Fuse wires in the explosive cartridges are continuously tested for continuity. If all circuits are operating properly, two 1000 ufd 450V capacitors are charged to about 300 VDC arming the fast-closing valve. Now the vacuum gate valve may be opened if less than one decade differential pressure exists across it. This valve must be opened within five minutes of arming the fast-closing valve or the firing circuits will automatically disarm. Once the five-minute period has elapsed and the gate valve has been opened, any interlock failure will cause the gate valve to close and the fast-closing valve to disarm. In about 20 hours of operation over a two-year period, there have been only two firings of the fast-closing valve, both due to false pressure bursts. Target failure was not the cause of the pressure burst in either case.

Increased sensitivity to slower pressure rises was tried but 60Hz present in the pressure signal caused false triggering of the SCR switches. A very fast (approximately 1 sec) ion gauge controller with DC filaments has been developed for use in beam lines where faster response and higher sensitivity are required.

6. SUMMARY

The use of an explosive cartridge is probably the fastest method of closing a vacuum valve and has proved to be extremely reliable.

Vacuum valves with larger openings could be constructed with a split body design since a one part body would be too massive. Material and bolt strength would have to be matched to the required explosive force to close the valve in the desired time range.

The electronic firing system is generally applicable to any fast-closing valve.

ACKNOWLEDGEMENTS

We wish to thank David Plate for his artistic drawing of the report figures. The helpful discussions with Henry Lancaster and Ron Yourd and their continued interest in the project are greatly appreciated.

This work was supported by the Director, Office of Energy Research, Office of High Energy and Nuclear Physics, Division of High Energy Physics of the U.S. Department of Energy under Contract No.

W-7405-ENG-48.

REFERENCES

1. R. A. Gough, R. Lam, C. Martinez and D. Morris, Nucl. Instr. and Meth. 138 (1976) 415.
2. Available from Horex Inc., Hollister, Ca 95023, USA.
3. Available fromk PCB Piezotronics, Inc., Buffalo, N.Y. 14225, USA.

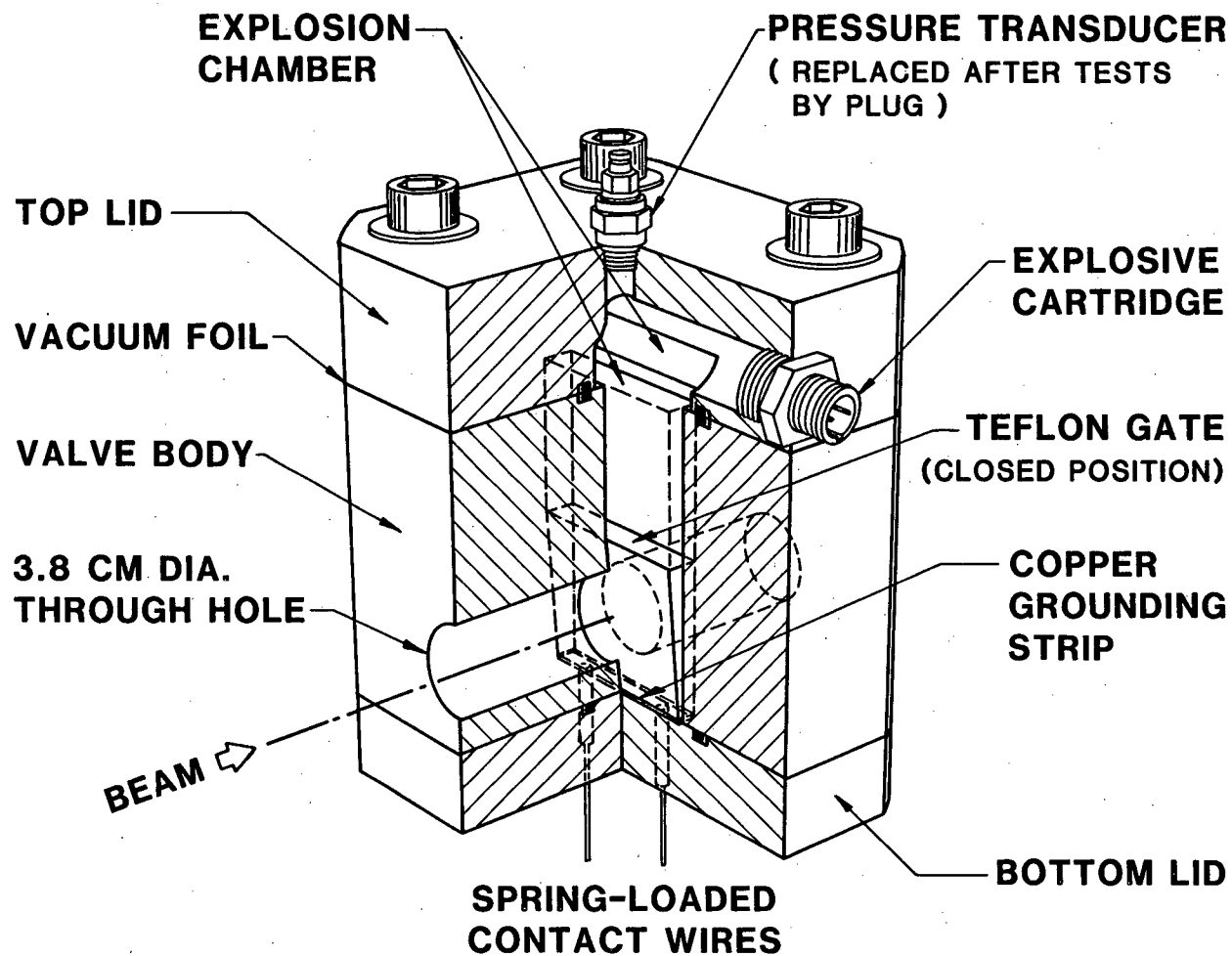

**FIG. 1 A CROSS-SECTION OF THE FAST-CLOSING VALVE**

XBL 816-10181

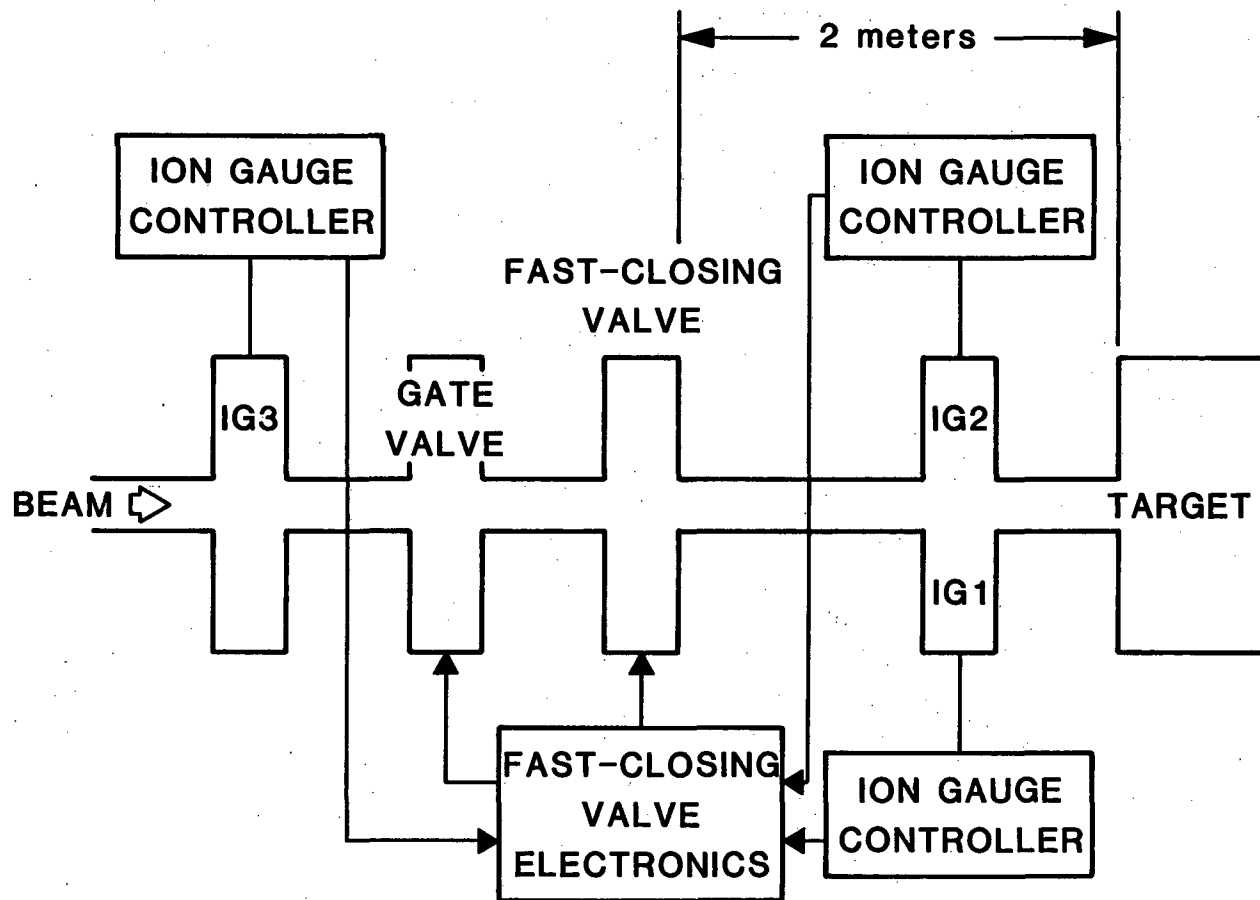

Fig. 2 A BLOCK DIAGRAM OF THE FAST-CLOSING VALVE INSTALLATION

XBL 816-10179

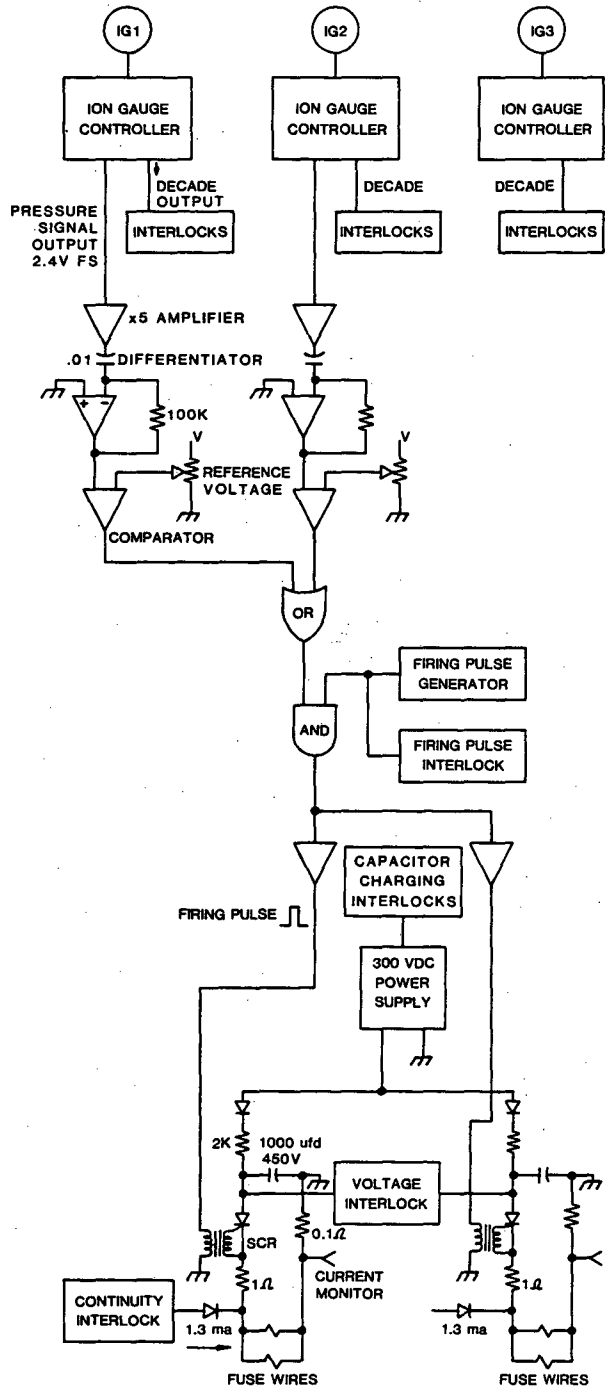
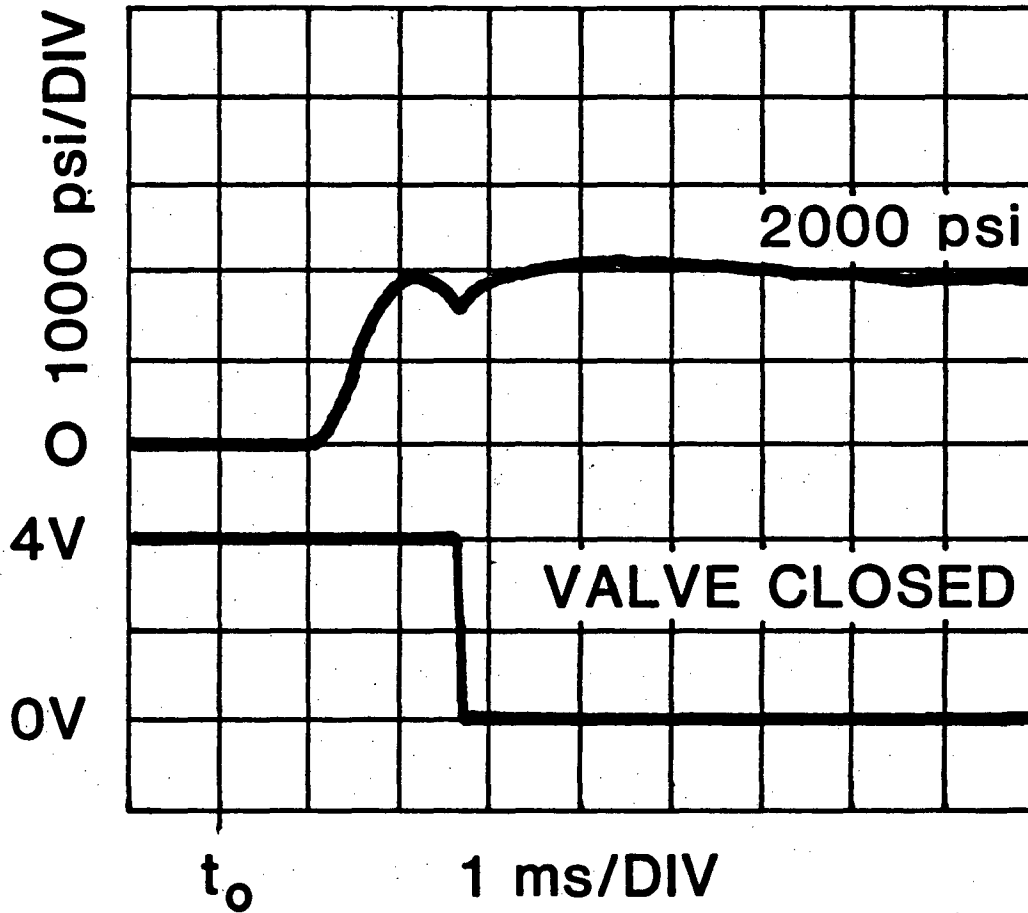

Fig. 3 A SIMPLIFIED BLOCK DIAGRAM OF THE VALVE FIRING SYSTEM

XBL 816-10180



**Fig. 4 OSCILLOSCOPE TRACES  
OF VALVE CLOSING TIME AND  
EXPLOSIVE PRESSURE IN CHAMBER**

XBL 816-10078



This report was done with support from the Department of Energy. Any conclusions or opinions expressed in this report represent solely those of the author(s) and not necessarily those of The Regents of the University of California, the Lawrence Berkeley Laboratory or the Department of Energy.

Reference to a company or product name does not imply approval or recommendation of the product by the University of California or the U.S. Department of Energy to the exclusion of others that may be suitable.

TECHNICAL INFORMATION DEPARTMENT  
LAWRENCE BERKELEY LABORATORY  
UNIVERSITY OF CALIFORNIA  
BERKELEY, CALIFORNIA 94720