

UC Berkeley

Envelope Systems

Title

Occupant Response to Window Control Signaling Systems; Appendix C: Mixed-mode Signal Case Study Summary

Permalink

<https://escholarship.org/uc/item/61t8z6ff>

Authors

Ackerly, Katie
Brager, Gail

Publication Date

2011-04-01

Copyright Information

This work is made available under the terms of a Creative Commons Attribution License, available at <https://creativecommons.org/licenses/by/3.0/>

Window Signaling Systems: Case Study Summaries

Appendix C

Group 1 Concurrent air supply, outdoor temperature control

1. 654 Minnesota Avenue, UCSF, San Francisco CA
2. Boalt Hall, University of California Berkeley, Berkeley California
3. ZGF Architects Offices, Portland, OR

Group 2 Concurrent air supply, outdoor + indoor temperature control

4. Thornburg Headquarters, Santa Fe, NM
5. Kirsch Center for Environmental Studies, De Anza College, Cupertino, CA
6. Applied Research and Development (ARD) Facility, Northern Arizona University, Flagstaff, AZ
7. William and Flora Hewlett Foundation Building, Menlo Park, CA

Group 3 Discontinued air supply, outdoor temperature control

8. Lincoln Hall, Berea College, Berea, KY
9. Phillip Merrill Chesapeake Bay Foundation Building, Annapolis, MD
10. Kroon Hall, Yale University School of Forestry Building, New Haven, CT
11. Zoomazium, Woodland Park Zoo, Seattle, WA

Group 4 Discontinued air supply, outdoor + indoor temperature control

12. NBBJ Architects Offices, Seattle WA
13. Savery Hall, University of Washington, Seattle WA
14. Orinda City Hall, Orinda, CA *This could also be considered a variation of Group 1 or Group 3 building

Group 5 Decoupled cooling and ventilation

15. Compton Union Building (CUB), Washington State University, Pullman, WA
16. Boora Architects Offices, Portland OR

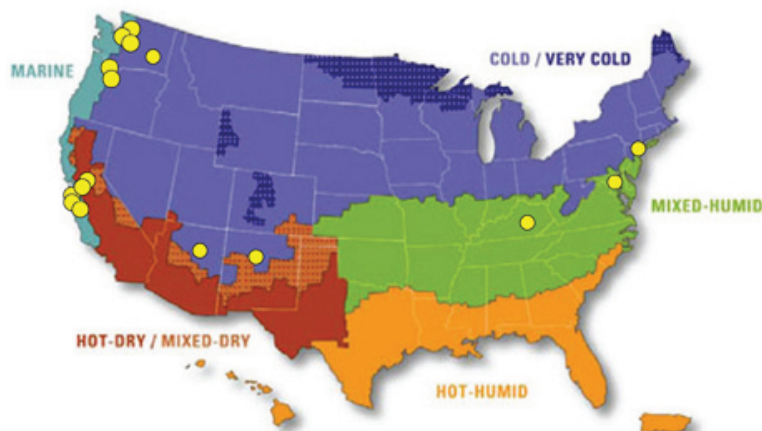

1. 654 Minnesota Avenue, UCSF, San Francisco CA

Group 1 Concurrent air supply, outdoor temperature control

Project Scope	Owner-occupied adaptive re-use of 1980s industrial building with operable windows
Architect	STUDIOS Architecture
Mechanical Engineer	Taylor Engineering
Year Completed	2008
Perimeter Program	Large open office plan, three workstations from window
Occupants	150

Intent of Signals

To moderate personal window control. Window use is allowed when outdoor temperatures are between 55-75° F (roughly the building's normal economizer cycle), and discouraged otherwise.

System Description

This project exemplifies the type of application in which the design team wanted to provide operable windows primarily as a personal control amenity for occupants. The existing industrial building had original operable windows, and the central goal of the project was to be as low-energy as possible. But the depth of the floor plates made it difficult to justify a dependence on the operable windows for air supply entirely. In a climate where a large percentage of operating hours are spent in economizer mode, however, keeping the windows operable was a reasonable gesture towards a more flexible, adaptable envelope. The signals were installed to maintain some measure of oversight and discourage open windows at times the HVAC system is actively cooling or heating. A set of red/green lights is suspended from the ceiling at either end of each circulation corridor. Placards that explain the meaning of the red and green lights were planned but ultimately rejected during project close-out. As a result, only the occupants who were present for an initial building orientation were directly informed about the system. Many others didn't notice the presence of the lights.



Red/green signals are located overhead in corridors, with other utilities



Typical operable window adjacent to workstation.

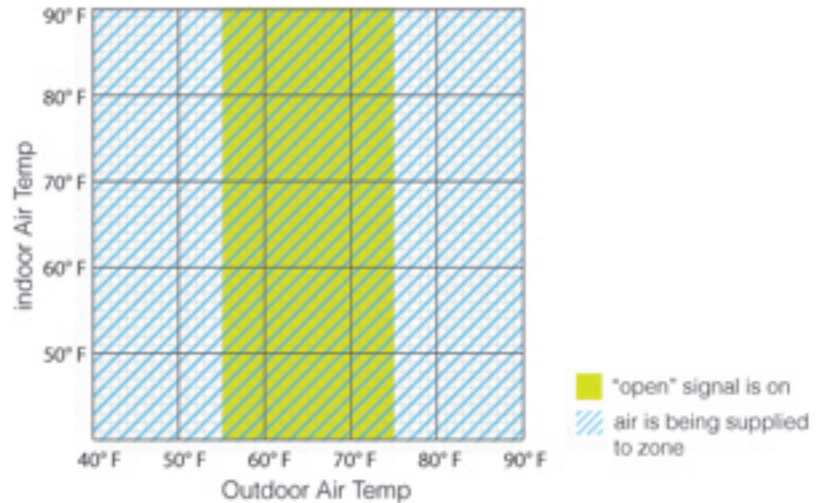

Operating Conditions and Occupant Response

Based on interviews, site observations and survey responses, the lights function well and the green light is on at times that make sense, but the occupants are generally disengaged from the routine of operating windows, either because they are unaware, busy, comfortable, physically removed from the window, or off-site, where many staff spend a good portion of their workdays. Because comfort satisfaction is very high, and the building operates as it would otherwise when the green light is on, there is little reason or incentive to reinforce the system. By and large, preventing energy waste during the red light mode is a more direct energy consequence, and the most important oversight issues include people leaving their windows open and the light turns red. Survey results show that over 40% of occupants are unaware of the system. In other projects where little has been done to educate, the responsibility has been assumed by the office manager, who goes around at the end of the day or when the light turns red to make sure windows are closed. Fortunately, because the space has an open plan and the windows aren't used very much, this places little burden on the building or its users.

2. Boalt Hall, UC Berkeley, Berkeley CA

Group 1 Concurrent air supply, outdoor temperature control

Project Scope	Renovation
Architect	Ratcliff
Mechanical Engineer	Taylor Engineering
Year Completed	2009
Perimeter Program	Small open office, classrooms, lounge
Occupants	2-3 full-time, mostly transient

Intent of Signals

To regulate manual window use. Window use is allowed when outdoor temperatures are between 55-75°F (roughly the building's normal economizer cycle), and discouraged otherwise.



System Description

During a recent renovation of Boalt Hall, operable windows were installed on the first floor, which contains two classrooms, a student lounge area, and the California law review office. The windows face south and west onto the public courtyard and busy plaza bounded by Bancroft ave, Wurster Hall, and Boalt. For security reasons, the windows open only four inches. The windows were installed to earn an additional LEED credit for increased thermal control. Because the building was to be mechanically cooled and ventilated, a set of red and green lights was installed to help avoid energy waste, or in the words of the engineer, provide “a way out of a bad situation.” They are placed just above head height next to each bay of windows.

Operating Conditions and Occupant Response

Because the space is occupied by student staff with irregular schedules and annual turn-over, we chose not to study this building in detail. However, we interviewed students on multiple occasions to get a feel for how much the windows are used. Although the people we spoke with were unaware what the signals were for, (there is no signage associated with them and they didn't recall receiving an email), they were very enthusiastic about the idea once they learned about it. Even though the windows don't open very far, the blinds



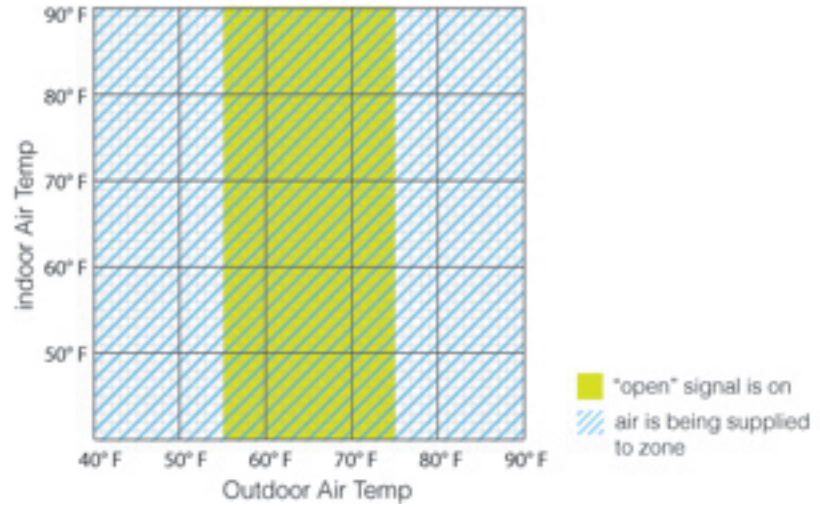

are often drawn and it is noisy outside, the students we interviewed said that the windows do get used, because they like the fresh air and connection to the outdoors.

3. ZGF Architects, Portland, OR

Group 1 Concurrent air supply, outdoor temperature control

Project Scope	Mixed use office/residential high-rise in downtown urban area designed by primary tenants
Architect	ZGF Architects
Mechanical Engineer	Stantec
Year Completed	2008
Perimeter Program	Large open office plan, 2 workstations deep
Occupants	245

Intent of Signals

To regulate manual window use. Window use is allowed when outdoor temperatures are between 55-75°F (roughly the building's normal economizer cycle), and discouraged otherwise.



System Description

In this project, the building was originally designed without a signaling system. The central idea was to provide a low-energy under-floor air distribution system and operable windows for personal control, given Portland's mild climate. The signaling system came about after a heat wave soon after move-in, when management noticed that staff were using the windows when it was too hot outside. The design team decided on a policy to inform and remind occupants about efficient window use based on outside air temperature. A digital indicator icon mounted on each occupant's PC taskbar was chosen, with blue (too cold), green (okay to open windows) and red (too warm) icons. The team decided against a "pop-up" notification to minimize the nuisance or "spam" factor.

Operating Conditions

No interview was conducted with the building operator and we are unaware of any major commissioning issues regarding the cooling and air distribution systems.

Occupant Response

654 Minnesota Ave (case #1) and ZGF offices received almost identical thermal comfort and air quality satisfaction scores. However, compared to the occupants at 654 Minnesota in San Francisco, staff at



Operable slender awning windows are removed a few feet from workstation clusters

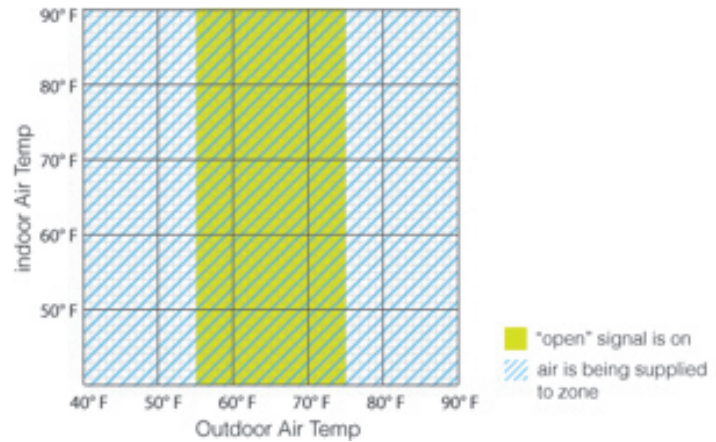
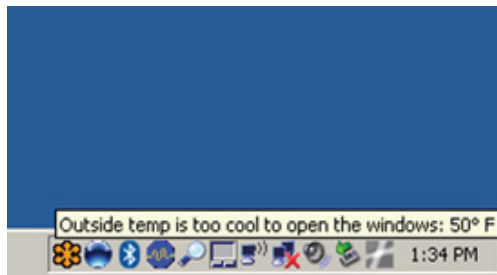

ZGF are more active window users, perhaps due to office culture, schedules, or more variable thermal conditions within the office. There were several complaints of overcooling in this building, attributed either to local drafts or to the set-points for “green light” mode being too broad. The level of knowledge and interest of the occupants is revealed in their survey comments; many put forth conflicting theories or proposals for how the system could be more effective.

Similar to Boora Architects (see Group 2) and NBBJ Architects (see Group 4), this project benefits from an occupant group that is relatively well-informed about the system (and potentially proud of their new space) compared to other buildings in the study. ZGF has the highest percentage of respondents (25%) who report “always” acting on the red or blue icons (55% responded in the categories of always + usually, which is second place). These results are promising considering the stated intent of the icons, which is to enlist staff in keeping an eye on outdoor temperature when the windows are open. However, because the building is larger and ZGF staff are more active window-users compared to those in 654 Minnesota, there could be higher risks associated with the equally large percentage of staff (~50%) who remain fairly ambivalent about or unaware of the system.

4. Thornburg Headquarters, Santa Fe, NM

Group 2. Concurrent air supply, outdoor and indoor temperature control

Project Scope	110,000 square-foot, 3-story office building in suburban area
Architect	Legoretta + Legoretta; Dekker/Perich/Sabatini Architects (Architect of Record)
Mechanical Engineer	Arup (Design Engineer); Bridges and Paxton Consulting Engineers (Engineer of Record)
Year Completed	2009
Perimeter Program	Private offices and open office bays 2 workstations deep
Occupants	195

Intent of Signals

To remind occupants that the building has low-energy systems and they have the opportunity to use their windows. Window use is allowed in the building as long as there is not a call for chilled water between the months of April and November

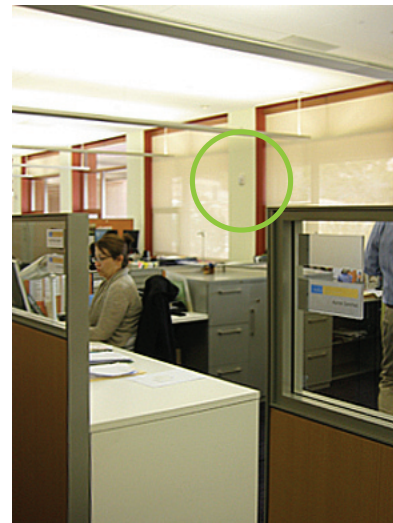

System Description

The local climate of Santa Fe is well suited to natural ventilation, but requires active cooling for significant periods as daily temperature can vary by as much as 30 degrees with high seasonal variation. In developing a mixed-mode system for the building, the design team was able to meet most of the cooling loads with evaporative cooling, and provided additional conventional chilled water to meet the few hundred hours per year evaporative cooling would be insufficient. The green indicator light used at Thornburg ultimately became a way to celebrate the building's low-energy design and to encourage people to use their windows when the building is either in evaporative cooling or economizer modes. Some members of the design team emphasized the psychological benefit of reminding occupants that they do not work in a sealed office environment, a message that was unique to this case.

Operating Conditions

Thornburg is the only case in which the control commands for the window indicator are tied directly to the commands for the mechanical system's operation. The building maintains fairly conventional heating and cooling setpoints of 72° and 75° F. Occupants do not have local thermostat control but can control air flow at local floor air diffusers. Initially, the green window

Typical private and open office areas



There is no control sequence diagram for this project

signal was set to be normally “off,” unless the economizer was enabled (outside air temperature must be below 65° F and at least two degrees below the return air temperature). This caused the lights to cycle on and off as the building modulated between modes. It was particularly confusing in one central area of the building, where cross-over within a double-height space connecting floors served by different air handlers made it difficult to control temperature. To address this problem, the control for the lights was set to default to “on” in all modes, unless there was a call for chilled or hot water. This provided some measure of coordination among the lights, but the consequence of this solution was the possibility for the green light to turn on during the heating season, when hot water supply cycled off and air was simply recirculated. As a result, the building operations team decided to disable the green light completely between the months of November and April, during which period they presumed no one would miss their windows.

Occupant Response

We were not able to survey occupants in this building, but a few informal interviews suggest that, despite the intent of making natural ventilation legible in the building, many people are still not in the habit of using their windows. One issue is the placement of the furniture next to the window in such a way that the hardware is out of reach without a special device that was fashioned by the building manager. However, access is probably not the primary reason; more commonly, it seemed that occupants are generally busy and comfortable, and don’t feel the need to use them. A sizable minority do appreciate the connection to the outdoors, as we found in other buildings. In the open office spaces, there is more conversation about adjusting windows and blinds, but this depends on the group of people sharing access.

Although there was no initial orientation about the system and no signage accompanying the green light, the building manager communicates regularly via email about the system; he finds the green light useful as a way to communicate what the building is doing generally. Based on talking to staff, they seem to appreciate this information, even if they don’t use their windows very often.

5. Kirsch Center for Environmental Studies, De Anza College, Cupertino, CA

Group 2. Concurrent air supply, outdoor and indoor temperature control

Project Scope	22,000 ft ² classroom and faculty office building in campus/suburban area
Architect	Van der Ryn Architects (Design architect) and VBN Architects
Mechanical Engineer	ARUP
Year Completed	2005
Perimeter Program	private offices, classrooms, student lounge
Occupants	8

Intent of Signals

The purpose of the signals is two-fold: to keep the windows closed while the building is being actively heated or cooled, and to make the natural ventilation strategy visible to students and other occupants.

System Description

The building design is split into east and west wings, with radiant slab cooling in the west wing and underfloor conditioned air on the east.

A core goal for the Kirsch Center was to provide a “teachable” building with highly visible efficiency features. Operable windows were a part of the original design proposal, but campus facilities staff were skeptical, arguing that acutators were necessary to keep pressure and temperature balanced. The signals were selected as a compromise, providing some measure of oversight to prevent windows from being left open.

Operating Conditions

The Kirsch Center has been celebrated as an example of successful high performance design, and achieved among the highest occupant satisfaction scores in the CBE survey database out of roughly 400 buildings (conducted in 2005; we did not run another survey for this study).

The operation of the signaling system itself is less clear, particularly how much time the building spends in “open” mode. According to the design engineer, the original intent was for the light to be green “most of the time” because the climate is so mild. But the signals



A red/green light with instructional text is mouted at eye level on the wall next to each window in private offices, classrooms, and shared worspaces. In the classrooms, they are mouted next to the thermostat and blind controls.

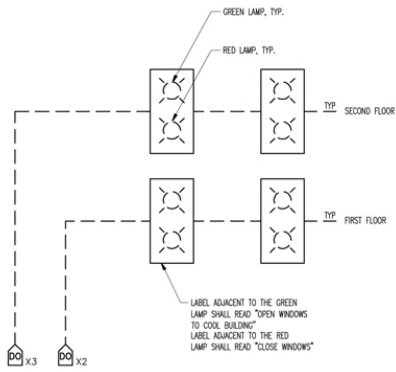

SEQUENCE OF OPERATION

THE INDICATOR LAMPS ARE INTENDED TO ASSIST THE BUILDING OCCUPANTS AND MAINTENANCE STAFF TO KNOW WHEN TO OPEN THE BUILDING UP FOR VENTILATION AND WHEN TO CLOSE IT DOWN. ILLUMINATE THE UPPER GREEN LAMP WHEN ANY OF THE FOLLOWING ARE TRUE:

1. BETWEEN THE HOURS OF [6pm] AND [6am] THE INSIDE TEMPERATURE IN THE PARENT SPACE IS HIGHER THAN THE OUTSIDE TEMPERATURE AND THE OUTSIDE TEMPERATURE IS [50°F] OR GREATER.
 2. BETWEEN THE HOURS OF [6am] AND [6pm]
 - A. THE INTERNAL TEMP IS ABOVE THE MAXIMUM ADAPTIVE COMFORT TEMP AND OUTSIDE TEMP IS BELOW INDOOR TEMP.
 - B. THE INTERNAL TEMP IS BELOW THE MINIMUM ADAPTIVE COMFORT TEMP AND OUTSIDE TEMP IS ABOVE INDOOR TEMP.
- ILLUMINATE THE LOWER RED LAMP WHENEVER THE UPPER GREEN LAMP IS NOT ILLUMINATED.

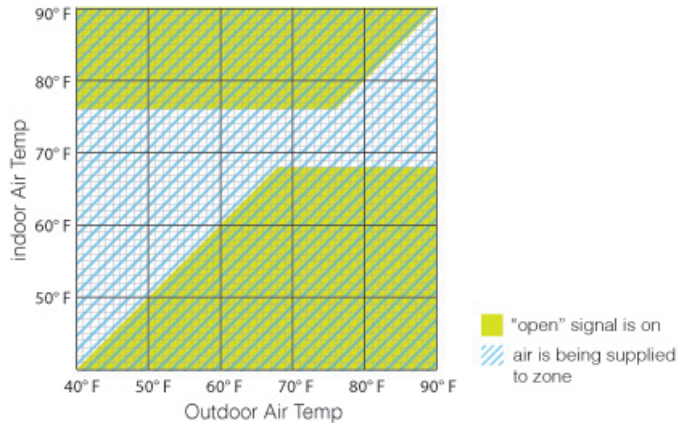

seem to work primarily in the swing seasons during the evenings. According to the controls contractor, the signals are not intended to work during the summer months while the chilled water plant is serving the building. The idea behind the control algorithm as written in the design documents is to encourage natural ventilation when outdoor temperatures are either warm or cool enough to meet indoor needs, and indoor temperatures exceed the adaptive comfort range. For this condition to be met however, the mechanical systems must allow the building to float beyond the established comfort setpoints. In this building and the ARD facility (next case), which was designed the same way, a mis-translation of this principle in the as-built controls may be causing the “close” signal to be on more than expected.

Occupant Response

The building has approximately 8 full-time staff with variable schedules, occupying a private office cluster on the southeast end of the building (on the afternoon of our visit, only three faculty were there). The building is otherwise occupied by transient users (teachers and students). From talking to one teacher who uses the classrooms, knowledge about the signals varies. One student staffing an information desk said she was aware of the system and would go to open the windows when the light turned green, although this didn't happen often.

Because there are few full-time staff, communication and reinforcement about the signs happens mostly verbally and “by example.” A few faculty take the lead in informing students and teachers who use the classrooms about the system, emphasizing that the signals “are a should, not a shall.” But new policies have been established to deal with conflicts. Private office occupants were told that it probably made little difference how they used their windows, but to close their door if they wanted to open their window while the light is red.

The “teaching tool” aspect given the academic setting is unique to this building, and it introduces questions about what is exactly is being taught, since it is unclear to users of the building how the signals are programmed. The building manager (who is a faculty liaison, not campus facilities staff) said she wished she had better access to the building controls and as-built design documents.

6. Applied Research and Development Facility, Northern Arizona University, Flagstaff AZ

Group 2. Concurrent air supply, outdoor and indoor temperature control

Project Scope	56,000 ft ² , 4-story building housing faculty offices, classrooms and a student lounge area
Architect	Hopkins Architects and Centerbrook Architects and Planners
Mechanical Engineer	ARUP
Year Completed	2009
Perimeter Program	Private and shared enclosed offices, open student lounge on fourth floor
Occupants	60

Intent of Signals

As stated in the sequence of operations: “The indicator lamps are intended to inform the building occupants when it is appropriate to open the building’s northwest perimeter windows to improve comfort conditions in the space and when it is inappropriate to open them”

System Description

The ARD facility has narrow floorplates that curve to the south, with private offices lining the north facade and open offices three workstations deep situated in the core. The south facade encloses a triple-height gallery space that acts as a thermal buffer for the building, with well-designed exterior solar control and exposed thermal mass. The gallery is naturally ventilated and has a supplemental zoned radiant floor system that is separate from the primary heating and cooling circuits in the rest of the building. Natural ventilation louvers operate in stages to maintain the temperature in the gallery between 68 and 79 F and CO₂ levels below 900 ppm. The radiant floor is operated in cooling mode based on predictive temperature controls and a wide deadband (65-80) so that pre-cooling of the slab and natural ventilation do the most work to maintain comfort.

The labs and office spaces are served by 5 air handling units. In cooling mode, the economizer, evaporative cooling coil and cooling coil modulate in sequence to achieve a supply air temperature of 65 F. Back-up chilled water is available between April and October when outside air temperature is above 65 F. Air is delivered via an underfloor plenum and motorized VAV



The atrium provides a thermal buffer for the north-facing offices



Signals are located below the window in each private office

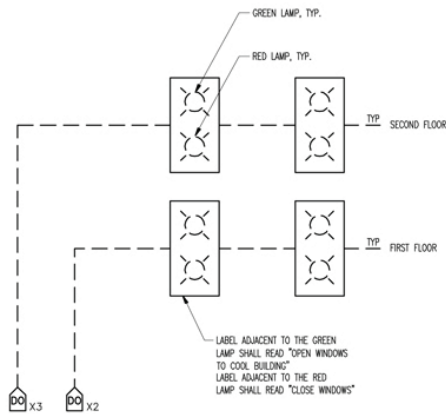

SEQUENCE OF OPERATION

THE INDICATOR LAMPS ARE INTENDED TO ASSIST THE BUILDING OCCUPANTS AND MAINTENANCE STAFF TO KNOW WHEN TO OPEN THE BUILDING UP FOR VENTILATION AND WHEN TO CLOSE IT DOWN. ILLUMINATE THE UPPER GREEN LAMP WHEN ANY OF THE FOLLOWING ARE TRUE:

1. BETWEEN THE HOURS OF [6pm] AND [6am] THE INSIDE TEMPERATURE IN THE PARENT SPACE IS HIGHER THAN THE OUTSIDE TEMPERATURE AND THE OUTSIDE TEMPERATURE IS [50°F] OR GREATER.
2. BETWEEN THE HOURS OF [6am] AND [6pm]
 - A. THE INTERNAL TEMP IS ABOVE THE MAXIMUM ADAPTIVE COMFORT TEMP AND OUTSIDE TEMP IS BELOW INDOOR TEMP.
 - B. THE INTERNAL TEMP IS BELOW THE MINIMUM ADAPTIVE COMFORT TEMP AND OUTSIDE TEMP IS ABOVE INDOOR TEMP.

ILLUMINATE THE LOWER RED LAMP WHENEVER THE UPPER GREEN LAMP IS NOT ILLUMINATED.

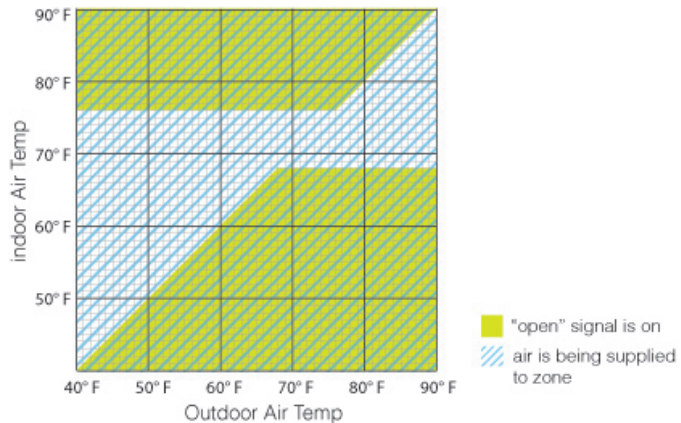

diffusers are controlled by room temperature sensors with an override for CO₂ detection (700 ppm setpoint).

Because the atrium and the office areas are served by independent systems, the windows serve different functions: in the atrium, they are primarily for night ventilation, while in the offices they are intended for local supplemental cooling and ventilation. In theory, using the windows would offset fan energy by allowing the demand-controlled VAV system to modulate air supply in response.

Operating Conditions and Occupant Response

The ARD facility houses several different university departments and environmental research groups. Comments about the windows in our survey suggested over-arching control issues, rather than persistent comfort complaints. Due to the success of the gallery design and Flagstaff's sunny, mild, dry climate, thermal comfort may not always be an issue; but when there are comfort concerns, the reliability and responsiveness of control measures do not seem to meet occupant expectations. The primary example noted by the building manager referred to the lighting controls, which malfunction frequently and are so sophisticated that trouble-shooting is only possible via calls to a controls contractor in Phoenix. Occupants of this building are the least satisfied with their windows as well as their the windows' ability to provide comfort of all the buildings in the study (55% dissatisfied, 40% say window is only somewhat effective); this does not mean that dissatisfaction is widespread, but there are various interfering factors, including difficulty controlling the windows on windy days, as noted by several people.

This building also received the lowest scores in terms of occupants' "active" response to the signals. Most people who offered comments about the signals said that the red light is "always on" (the others said the signals weren't visible to them, they hadn't been told about them, or the system was flawed because stuffiness was an important factor). Like the Kirsch Center, which was designed the same way, a mis-translation of the control algorithm may be causing the "close" signal to be on too often, but we were unable to confirm the as-built controls.

7. William and Flora Hewlett Foundation

Group 2. Concurrent air supply, outdoor and indoor temperature control

Project Scope	48,000 ft ² , 2-story building
Architect	BH Bocook, Architects, Inc
Mechanical Engineer	Critchfield Mechanical, Inc
Year Completed	2002
Perimeter Program	Private offices
Occupants	150

Intent of Signals

The purpose of the indicators are to improve the efficiency of the building by keeping people from opening windows when the building is actively heating or cooling the building.

System Description

Cooling is provided by an evaporative cooling and ice storage system to reduce peak demand. Two air handlers supply conditioned air to each wing of the building via an underfloor plenum with manually-operable floor diffusers. In the perimeter zones, heating coils are placed in the raised floor.

The operable windows were one of several features that are meant to give people more control over their environment, creating a more domestic, “family” feel for the building. In the building controls, the windows were considered as part of the building’s economizer cycle. The design documents state that, when sensors determine that the return air is warmer than the outside air and the outside air is between 50 and 78 degrees Fahrenheit, the BMS initiates an economizer mode, simultaneously opening clerestory windows for stack-driven exhaust and initiating the green light.

Operating Conditions and Occupant Response

An earlier occupant survey of this building in 2004 revealed that thermal comfort satisfaction was relatively poor (52% satisfied). The survey also happened to ask some custom questions about the signaling systems, and discovered that many people reported the light to be red most of the time, or “always.” Although we were not able to survey occupants again or monitor the hours



Signals are installed in the circulation areas between perimeter and core offices



Typical perimeter office

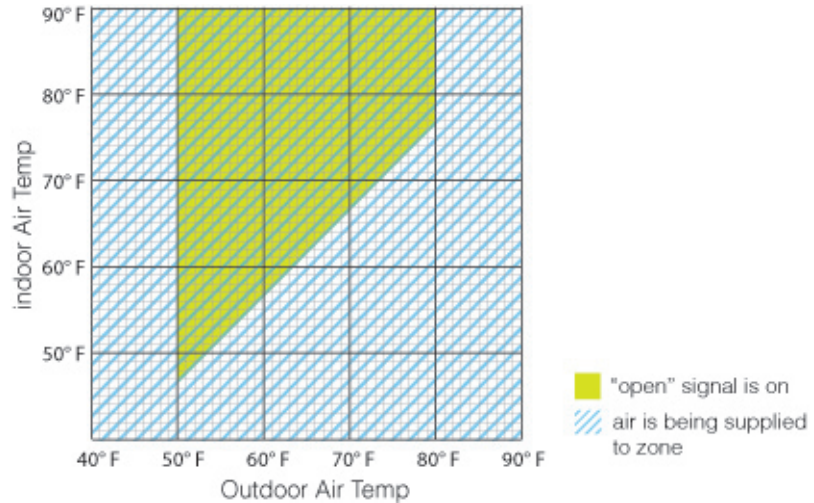

spent in green mode, this issue seems to persist. Again, we were unable to confirm the as-built control sequence, but the problem seems to stem from ongoing challenges the building management team has had heating the building, particularly the core. It could be that the economizer is over-sized, requiring outside air to be heated to address comfort complaints in the core. As stated by the building manager, “because the building is always doing something, the light is not often green.”

We were unable to administer a second survey or interview occupants, but the building operations staff are above average in their interaction with occupants and understanding of comfort conditions. Each new hire is given a building orientation with the building manager when they move into their office. They are told that there are five ways to effect room temperature in each office, particularly in the perimeter offices. Occupants can adjust the air flow or placement of their floor diffusers, adjust the windows and blinds, or request a change in the zone set point. People are informed of the red/green light system, encouraged to use their windows, and are instructed to close the window at the end of the day. They are not encouraged to check the red/green light system throughout they day to dictate their behavior, because “people should feel like they can open the window if they want to.” There is a policy that asks occupants to close their door if they wanted to open the window when the light was red. But the building manager also wanted to be clear that the window signals are by and large seen as a “nice idea” that, like other design ideas, when confronted with the reality of how people work don’t play a big role in how people use the building. In the 2002 survey, most comments regarding the lights reflected a general awareness and respect for the idea amidst ambivalence about acting on it. However, one peculiar comment unveiled the complete thought process of a conscientious window-user when presented with conflict:

“I assume the red light means that energy is being used to modify the temperature inside and therefore if I open my window it will waste energy. Even so I open the window frequently, but when I do this I close the office door. However I don’t like the way that the closed door separates me from co-workers. So I put a sign on the door to let them know they can come in any time. But having the door closed is still very isolating, even though it is glass. I would open the window more if the light were green more and if I didn’t feel I needed to close the door, ie. if I knew that opening the window wouldn’t waste energy.”

8. Lincoln Hall, Berea College, Berea, KY

Group 3 Discontinued air supply, outdoor temperature control

Project Scope	Gut rehab and modernization of historic campus building
Architect	EOP Architects
Mechanical Engineer	CMTA Engineering Consultants
Year Completed	2002
Perimeter Program	Private and shared enclosed offices
Occupants	50

Intent of Signals

To remind occupants to use their windows on warm days, to maximize hours the building can be served by outside air only, and to minimize air conditioning, particularly during swing seasons.

System Description

After a minor collapse of the central interior in 2001, Berea college decided to fully renovate the building, taking advantage of the new, unplanned central atrium to enhance natural ventilation. Lincoln Hall was renovated when the campus switched from coal-fired central steam boilers to new central natural gas boilers and central chillers. During the renovation the building was fitted with a new central air handling system with local thermostats and VAV boxes in each room that regulate overhead air supply based on demand (CO₂). The building is designed to save 30% over ASHARE standard 90.1-1999, primarily by shutting the air handling system down and prompting occupants to open their windows within given outdoor temperature and humidity limits (55-75 is assumed, not confirmed). Because of Kentucky's climate, the benefits occur primarily during the swing seasons.

Operating Conditions and Occupant Response

Staff in Lincoln Hall are very well informed about the green light system in the building. They are each given a personal orientation about the system and the importance of using windows to offset air conditioning. This is most likely the reason over 50% of occupants surveyed reported "always" or



Photos courtesy EOP Architects

We were unable to collect images of the office and the green light signal.

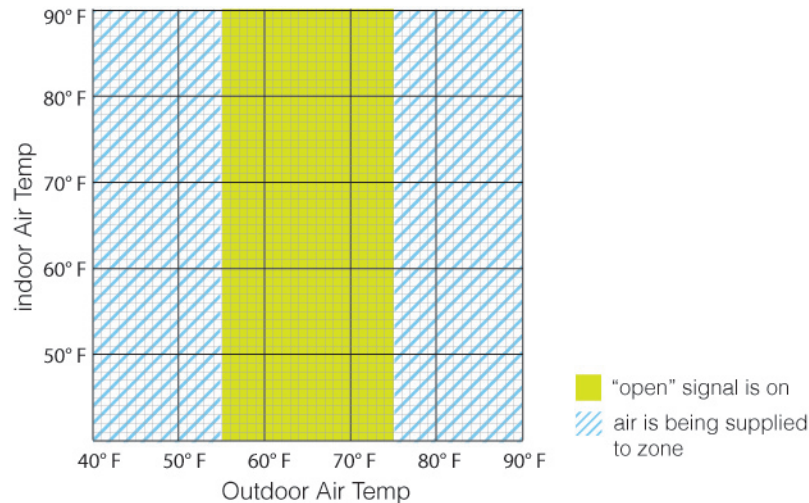

“usually” responding to the green light. This level of training is the only commonality linking the three buildings that achieved this level of success. However, comfort issues from overheating are recurring and fairly common based on survey comments, and so when the light is red, occupants operate the windows as they see fit to stay comfortable regardless of what the green light says. This could be a failure to emphasize the importance of keeping the window closed when the red light is on; however, one occupant reported indoor temperatures as high as 83 degrees, even with the green light on, and two occupants reported that the green light is routinely not on when it seems comfortable outside and its too hot inside. We were not able to discern what this discomfort can be attributed to, but given the high humidity in Kentucky, it could be reaching the limits of mixed-mode applications. It would be important to understand whether this problem persists during the summer when chilled water is available, or if it’s just a swing-season problem. When windows are needed, window use is also complicated by a few window access problems (people climbing on fixed furniture in at least two offices), pollen issues that seem like they could be serious, and sometimes noise. A couple people were troubled by the necessity of the windows given that pollen was such a problem.

9. Chesapeake Bay Foundation, Annapolis MD

Group 3 Discontinued air supply, outdoor temperature control

Project Scope	32,000 ft ² 2-story office building for environmental protection organization, first LEED Platinum building in the US
Architect	Smithgroup
Mechanical Engineer	Smithgroup
Year Completed	2000
Perimeter Program	Open offices
Occupants	105

Intent of Signals

To enlist the occupants in operating the building for natural ventilation in lieu of window actuators



Photos courtesy Smithgroup

System Description

Chesapeake Bay Foundation is the earliest and most well-known application of window signaling systems in the U.S. The idea of using operable windows to passively cool the building was identified during schematic design. The team did some modeling to estimate what percent of the year natural ventilation could serve the building (10%, mostly during swing seasons was the expectation; this turned out to be conservative). The client couldn't afford motorized controls so the engineer proposed a modified exit sign as a low-tech, subtle way to compel users to participate. The value of engaging occupants was an unspoken understanding between the design team and the client and never questioned.

The windows are cranked casements, four on one crank, one crank every ten feet. Twelve people share access to a crank. The idea was an "army mentality" where the occupants were meant to be very active in responding to the signs, according to the building manager.

Operating Conditions and Occupant Response

We were unable to conduct a site visit or survey;



Photos courtesy NREL 2004

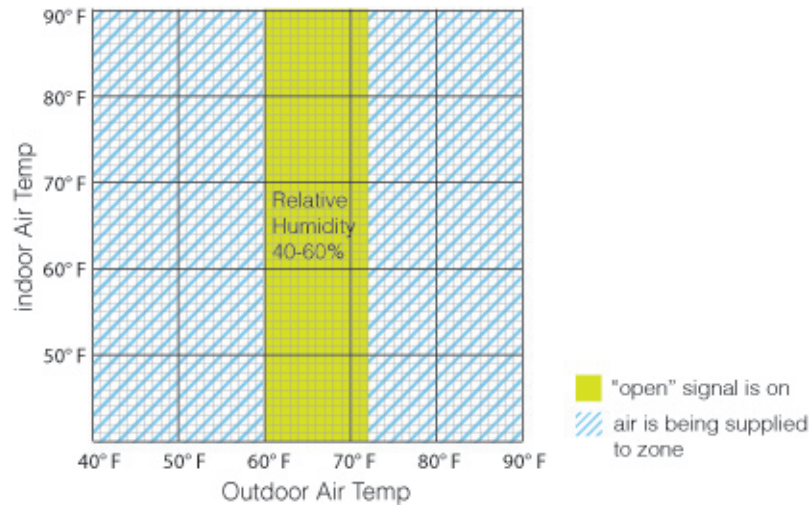

however, this building was previously surveyed by the CBE, and the operation of the signaling system was studied by the National Renewable Energy Laboratory, who found little persistence in occupant response to the signs; and by a graduate student at MIT, who recommended shifting the “open” signal setpoints down to 46-72 F to compensate for internal gains. (Chang, 2002)

The person in charge of operating the building during the first several years of its life did a lot to tweak the setpoints and worked with staff to see how low wide he could set the comfort range without having people complain. Thanks in part to the diligence of the building operator in continuous monitoring and tuning the building systems, the building is acclaimed as exceeding its energy saving goals, spending more hours than anticipated in natural ventilation mode. However, researchers we spoke with who have worked on the building agree that, based on anecdotal evidence, occupants have not been persistent in acting on the signals.

10. Kroon Hall, Yale School of Forestry, New Haven, CT

Group 3 Discontinued air supply, outdoor temperature control

Project Scope	56,000 ft ² , 4-story building housing faculty offices, classrooms and a student lounge area
Architect	Hopkins Architects and Centerbrook Architects and Planners
Mechanical Engineer	Arup
Year Completed	2009
Perimeter Program	Private and shared enclosed offices, open student lounge on fourth floor
Occupants	60

Intent of Signals

To allow the building to be purely naturally ventilated given outdoor air temperature, humidity and wind conditions. Signals intended to inform occupants about what the building is doing, but building operates independently of occupant behavior.

System Description

The design goals for Kroon Hall stemmed from an ambition to push the envelope of sustainable design practices and create a building that did not rely on the campus' chilled water or steam system. Narrow floor plates, effective exterior shading and the use of thermal mass was intended to keep cooling loads down. The building is served by four air handlers, which are coupled to ground-source heat pumps and deliver conditioned air via and under-floor plenum. Three of the four air handlers serve the office spaces with windows, and the central fans shut off during natural ventilation mode, reducing overall power consumption from 30 kW to 8 kW. Natural ventilation mode falls between 55 and 75 F outside air temperature, depending on humidity and wind speed criteria, and these conditions are all monitored by a dedicated weather station. The fourth air handler serves the classrooms, operates full-time, and slows to provide minimum outdoor air based on CO₂ levels. A set of green and amber lights, notifying occupants of natural ventilation mode, are installed in the central corridors at either end of each floor. They are installed high on the wall



Signals are installed at either end of each floor in public circulation areas.



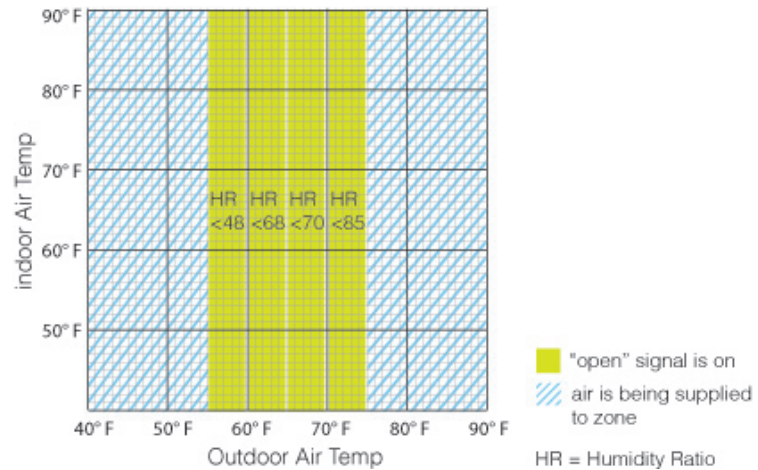

and are not accompanied by signage. However, the system emails staff automatically when the building enters and leaves “green light” mode.

Operating Conditions and Occupant Response

By design, this project is similar to the cases in group 1, except that the operable windows are intended to essentially replace the building’s economizer cycle in spaces where people have daily access to windows. However, this building differs from the buildings in group 4 because occupant behavior has no bearing on the status of the lights or the supply of air to the zone. If people fail to open their windows during the “open” mode, the consequences are comfort-related only, and survey results and informal interviews suggest that the mass of the building seems to do a good job regulating indoor temperatures. Whether or not occupants follow the green light is not of great concern to the building operator. However, similar to other buildings in Group 3, failure to observe the amber light could cause serious temperature control problems since the climate experiences both cold and hot-humid extremes.

When the system is working, Kroon Hall spends most of its operating hours in natural ventilation/”green light” mode during the swing seasons (April, May, September, October). However, the red light was on for the majority of 2010, either due to commissioning issues with the ground-loop system that resulted in adjustments to the humidity set-points, or a malfunctioning of the weather station. We were unable to confirm which one, but the weather station seems the most likely culprit.

The simplicity of the building’s overall design and the control logic for the green light provide a good model for future mixed-mode buildings with signaling controls. However, there are a number of lessons to be learned. First, the signals themselves are very easy to miss, especially for staff working in the middle of the hallway. According to staff interviews, email notifications turn into spam if received on a daily basis, as is the case during a typical fall day. In general, similar to Savery Hall, occupants are given very little reason to take the system seriously given that they are situated in their own, private offices, and have experienced other commissioning issues with the building. As a result, active response to the green and amber lights, awareness levels, and willingness to comply with the red light are all among the lowest in the study, despite overall positive indoor environmental quality satisfaction.

11. Zoomazium, Woodland Park Zoo, Seattle WA

Group 3 Discontinued air supply, outdoor temperature control

Project Scope	8,500 ft ² Interactive natural science exhibit space
Architect	Mithun
Mechanical Engineer	Flack + Kurtz
Year Completed	2006
Perimeter Program	Interactive nature “play space”
Occupants	1 full-time office staff, mostly transient staff and visitors.

Intent of Signals

To instruct staff to open manually operated windows intended to supplement automatic windows for natural ventilation and cooling.



System Description

The Zoomazium was designed to take advantage of the building’s small program and Seattle’s cool climate and use natural ventilation as much as possible. The building is served by a constant volume, variable temperature air handling unit and heat pump that delivers air via an underfloor plenum. The system maintains a cooling setpoint of 78 F and a heating setpoint of 72 F with a 4 degree deadband. When the outdoor temperature is between 60 F and 76 F, the green light turns on, indicating that opening the windows is allowed. When outdoor temperatures reach 66F, the air handler is disabled completely, and motorized transom level windows open to promote natural ventilation. The building also features a night flush mode between 1:00 and 4:00 am if the outdoor temperature is below 72 F and the indoor temperature is above 70 F.

Operating Conditions and Occupant Response

Because of the building’s unique program, we did not focus on this building in the study, but a few anecdotes from zoo staff and the building manager provide interesting lessons learned. Because of the nature of the building, staff see opening the windows as a part of their job, so the lights seldom go un-heeded; however, given the demands of the child-oriented, public interactive space, opening the windows can become a nuisance. Staff said they were confused about why all the windows could not be automated, and they reported



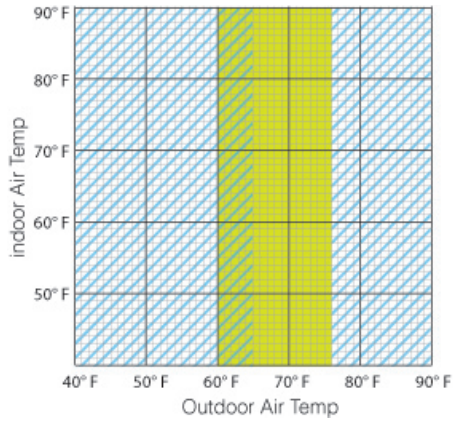

"open" signal is on
 air is being supplied to zone

Excerpt from Sequence of Operations, 2005

3.6 MANUAL OPERABLE WINDOW INDICATOR LIGHTS.

A. The Operable window indicator lights shall operate as follows:

1. When the outside air temperature is between 60°F (adj.) and 76°F (adj.) the green light shall be on and the amber light shall be off.
2. At all other times the amber light shall be on and the green light shall be off.

that the sytem works best in the summer, when the window opening task hits a predictable routine with one or more adjustments; during the swing seasons, when outdoor temperatures fluctuate more throughout the day, the signals can go on and off several times during the day, which gets cumbersome and annoying.

12. NBBJ Architects, Seattle WA

Group 4 Discontinued air supply, outdoor temperature control

Project Scope	New 5-story office/mixed-use development, designed by primary tenants, 2 floors leased to other tenants
Architect	NBBJ Architects
Mechanical Engineer	WSP Flack and Kurtz
Year Completed	2008
Perimeter Program	Large open office plan, three workstations deep
Occupants	315



Intent of Signals

Operable windows and signaling system are intended to provide cost-effective natural ventilation, and use HVAC energy only when necessary. Central air handler shuts off and window use is encouraged between 63-78°F outdoor temperature, or when indoor temperatures reach 78°, whichever comes first.



System Description

NBBJ Architects worked closely with the property developer and building engineer to push for an aggressive low-energy design that was 100% naturally ventilated. When the building owner discovered risk associated with leasing office space that didn't have air conditioning, the project shifted to a deep plan design with exterior fixed shades and a central air handling system serving all spaces via an under-floor plenum. The idea is that the building is naturally ventilated most of the year except for a few days when AC is needed. A low-profile green/amber light system is installed on the wall of the circulation corridor facing the office spaces, and is intended to enlist occupants in manually operating windows in place of a fan-powered economizer cycle. It was the first project where the engineers proposed a signaling system on such a large scale.



Operating Conditions and Occupant Response

In this project, the occupants include the architects involved in defining the goals of the project, and the building operator and office management are in close partnership educating occupants about

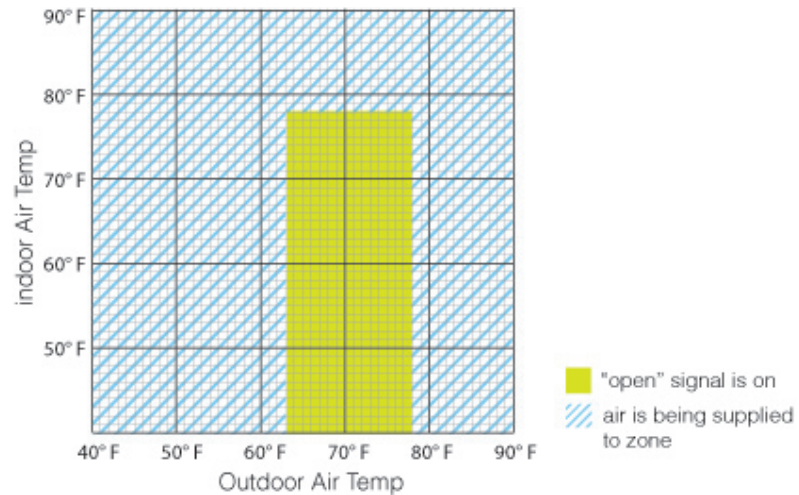
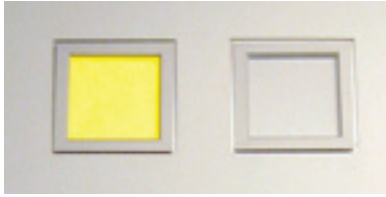

the system and addressing issues as they arise. As a result, survey results show very high awareness and active response rates (over 50% reporting “always” or “usually” acting on the green light).

Interestingly, occupant survey results show that the nuisance factor is also low; staff are not only more compliant but also more positive about the system than in other buildings, and are more likely to report that the system enhances their sense of personal control rather than interfering with it. Informal interviews in this and other buildings suggest this may be because signals favor window users in shared office settings who would otherwise be concerned about disturbing their coworkers.

From the perspective of management, however, the system is not flexible enough to meet the diverse expectations and preferences of different people in a large, open office, and speaking with occupants on site suggested general apathy about the system. Although survey results are positive, several comments point out ways the system could be improved. The main issue raised was a general over-cooling of the space and the complaint that the building shifts over to air conditioning mode too quickly. Indeed, because two floors are controlled by one air supply system, any one zone that reaches the relatively low indoor set-point of 78°F initiates the HVAC system throughout the spaces served by that air handler. Savery Hall and Boora Architects offices, which are also located in the Pacific Northwest and designed for natural ventilation, attempt upper set-points of 80-82°F. The width of the dead-band also affects how disruptive the signals are during the work-day. Survey comments suggested that the signals are a nuisance if the windows have to be adjusted more than twice a day, which happens during the swing seasons. Complicated window hardware and the tendency for windows to be left open over night were also concerns.

Overall, the success of the system in a building where there have been a number of operational and comfort issues points to the significance of occupant knowledge, culture and values in achieving design intent.

13. Savery Hall, University of Washington, Seattle WA

Group 4 Discontinued air supply, outdoor temperature control

Project Scope	Owner-occupied historic gut renovation/modernization
Architect	SRG Partnership
Mechanical Engineer	Wood-Harbinger
Year Completed	2009
Perimeter Program	Private faculty offices and classrooms
Occupants	120



Intent of Signals

To provide cost-effective natural ventilation, using HVAC energy only when necessary. Window use is allowed when outdoor temperature is within 60° and 75°F and indoor temperatures are within the comfort setpoints (68°-82° F). Once the cooling mode is initiated, the VRF will cool to 2° below the setpoint, allowing the green light to cycle back on.



System Description



During a recent gut renovation and modernization, the design team for Savery Hall was dedicated to enhancing natural ventilation to avoid the installation of a large air handling system. However, a number of circumstances made 100% natural ventilation difficult, including east-west exposure and restrictions on exterior solar control because of the building’s historic status. When CFD analysis showed risk of overheating on peak summer days, the design team decided to incorporate a small VAV system with distributed variable refrigerant flow (VRF) units for cooling and heating. To minimize the operation of the VRF system in cooling mode, red-green light indicators were installed to encourage occupants to use their windows. The signals are installed near or above the door to each office space and classroom and are accompanied by placards that explain the purpose of the red and green lights.

Operating Conditions and Occupant Response

Relative to other buildings in the study, it was common for occupants in Savery Hall to report

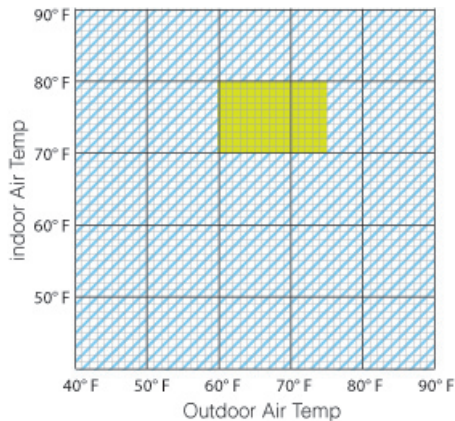



 "open" signal is on
 air is being supplied to zone

RED LIGHT/ GREEN LIGHT SEQUENCE OF OPERATION

1. THE RED LIGHT/GREEN LIGHT SYSTEM CONSISTS OF A PAIR OF LIGHTS MOUNTED IN EACH EXTERIOR SPACE. THE LIGHTS INDICATE TO THE OCCUPANT WHETHER OR NOT THE WINDOW IN THE SPACE SHOULD BE OPENED OR CLOSED. IF THE RED LIGHT IS ENERGIZED, THE WINDOW SHOULD BE CLOSED. IF THE GREEN LIGHT IS ENERGIZED, THE WINDOW SHOULD BE OPENED. THE DDC SYSTEM DETERMINES WHICH LIGHT SHOULD BE ENERGIZED BASED ON OUTDOOR AND INDOOR TEMPERATURE. DDC ALSO CONFIGURES THE INDOOR VRF UNITS FOR BOTH EXTERIOR AND INTERIOR SPACES IN CONJUNCTION WITH THE ABOVE TEMPERATURE READINGS.
2. VRF UNITS SERVING EXTERIOR SPACES: IF THE OUTDOOR AIR TEMPERATURE IS BETWEEN 60 DEG F AND 75 DEG F, AND THE INDOOR SPACE TEMPERATURE IS BETWEEN 68 DEG F AND 82 DEG F, COMMAND THE CORRESPONDING INDOOR VRF UNIT'S ON/OFF POINT TO OFF, AND ENERGIZE THE GREEN LIGHT. IF THE OUTDOOR AIR TEMPERATURE OR INDOOR SPACE TEMPERATURE MOVES OUTSIDE OF THE SPECIFIED RANGE BY 2 DEG F, COMMAND THE CORRESPONDING INDOOR VRF UNIT'S ON/OFF POINT TO ON, COMMAND ITS OPERATION MODE POINT TO AUTO, AND ENERGIZE THE RED LIGHT.
3. VRF UNITS SERVING INTERIOR SPACES: IF THE OUTDOOR AIR TEMPERATURE IS BETWEEN 60 DEG F AND 75 DEG F, AND THE INDOOR SPACE TEMPERATURE IS BETWEEN 68 DEG F AND 82 DEG F, COMMAND THE CORRESPONDING INDOOR VRF UNIT'S OPERATION MODE POINT TO FAN. IF THE OUTDOOR AIR TEMPERATURE OR INDOOR SPACE TEMPERATURE MOVES OUTSIDE OF THE SPECIFIED RANGE BY 2 DEG F, COMMAND THE CORRESPONDING INDOOR VRF UNIT'S OPERATION MODE POINT TO AUTO.

instances in which the red light was on when conditions outside seemed preferable to those inside (both cooler and warmer). This may be a function of factors such as cool surface temperatures or internal gains that cause variable thermal conditions not accounted for by the mechanical system, or it could be related to the control strategy for the lights.

To address the expected variation in loads among different spaces in the building, the control sequence for the green light includes indoor as well as outdoor temperature criteria, and each zone operates independently, which is unusual. Because indoor temperatures must be within the comfort range for the green light to be on, the mechanical system essentially assumes the responsibility for maintaining comfort. In Savery Hall, the cooling set-point is adjustable between 78° and 82°F, which is high, and thermal mass likely does a good job dampening gains during the summer, allowing the building to coast if people don't respond to the green signal. However, if internal gains are sufficient to raise the indoor temperature on a temperate day, it is possible for the red light and VRF to come on during hours that are theoretically still suitable for natural ventilation. One would have to monitor the operating hours in each mode to understand whether VRF units are operating for more hours than intended.

The fact that the building is large and occupants work in private offices on their own schedules is also an important factor. For the first year, general awareness of the system was low and communication about the meaning of the green and red lights was inconsistent. Since our study was conducted, a manual explaining the meaning of the signals was distributed to occupants. It tells them to regard the green light as an "option to satisfy temperature needs" within the wide comfort range defined by the building. The message for the red signal is stronger, that "it is important to close windows completely." Based on our findings regarding why people naturally use windows, we expect that a minority (~15 %) of occupants will still act on the green signal unless there's a stronger imperative; the majority will wait until they are uncomfortable; again, whether this matters to energy use isn't clear. It's also important to note that a bigger concern for management is how to ensure windows are not left open over night, particularly in classrooms. This is most likely the biggest energy question related to the operable windows, and it is unrelated to the signaling system.

14. Orinda City Hall, Orinda, CA

Group 4 Discontinued air supply, outdoor temperature control

Project Scope	Small, 2-story public building
Architect	Siegel and Strain
Mechanical Engineer	Taylor Engineering
Year Completed	2007
Perimeter Program	Combination of small open office space, shared workstation clusters and private offices
Occupants	40

Intent of Signals

Operable windows and signaling system intended to provide cost-effective natural ventilation. The “open” signal is controlled by outdoor temperature, and is on between 65° and 78°F. Air supply is shut off at the zone if temperature is within the acceptable comfort range (70 – 78°F).

System Description

The starting point for the design of Orinda City Hall was to eliminate compressor cooling by reducing internal lighting loads, using aggressive exterior solar control and high performance glass, and by providing occupants operable windows and ceiling fans to justify a wider range of acceptable indoor temperatures. The lower floor is partially earth-bermed to enhance passive nighttime cooling. When additional cooling is required, the building relies on an indirect evaporative cooling system.

The design team weighed several options for providing meaningful natural ventilation at low cost. A true change-over system with window interlock controls would have been ideal but was prohibitively expensive because it would have required each office space to be thermally compartmentalized. Instead, “open windows” signs were installed in corridors, where they are visible from open workstations, and hard to miss when leaving private offices. The “open” signal corresponds to outdoor air temperature, similar to the cases in group 1; however, even though the system is technically “concurrent,” allowing

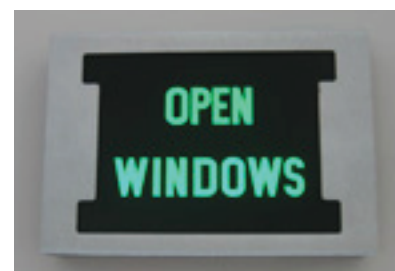

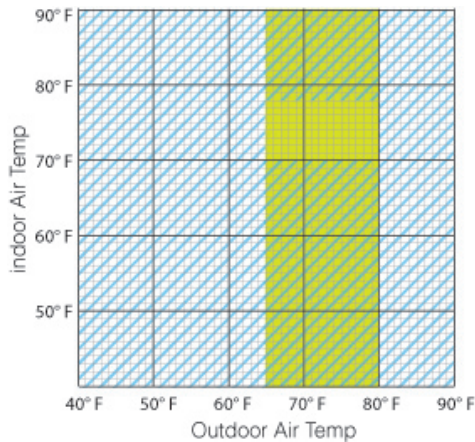

"open" signal is on
 air is being supplied to zone

Sequence of Operation, April 2005

3.02.C.6 Isolation Area operating modes

- b. Natural ventilation mode:
 - 1) An Isolation Area is in the Natural Ventilation Mode when all of the following are true:
 - a) The zone is in occupied mode
 - b) The outside air temperature is greater than 65°F (adjustable)
 - c) The outside air temperature is less than 78°F (adjustable)
 - d) The signal from the "manual close upper window & skylight" (disables natural ventilation) switch is not enabled
 - e) The isolation zone is above the heating setpoint
 - f) The isolation zone is below the cooling setpoint plus 2°F (adjustable)
 - 2) An Isolation Area is in the Natural Ventilation Mode when the associated window is proven open.

3.02.D.2. Setpoints

- a. Each zone shall have separate unoccupied, window open and occupied setpoints, and separate heating and cooling setpoint.
 - 1) As a default, the occupied heating setpoint shall be 70°F and the occupied cooling setpoint shall be 78°F.

3.02.E Dual-Duct VAV boxes (non-CO2 zones)

- 3.b. If the VAV box is tied to the natural ventilation mode, Vcool-max, Vheat-max and Vmin shall be zero when the room is in natural ventilation mode.

3.02.F Dual-Duct VAV boxes (CO2 zones)

- 3.c. During natural ventilation mode boxes serving zones that are served by operable windows shall operate with Vmin at zero unless the Natural Ventilation has been overridden. CO2 reset shall operate to reset Vmin, see 3.02F.3.e and 3.02F.3.fC. All zones will have Vmin at zero during Natural Ventilation mode except zones 1-3, 1-4, and 2-8.

the simultaneous use of central air supply and windows, ventilation energy is minimized by shutting off air supply at the VAV box when the zone temperature is within heating and cooling setpoints.

Operating Conditions

During its first year of operation, the building experienced overheating and humidity issues due to a series of heat waves combined with an undersized evaporative cooler that was mistakenly installed. Even after the problem was fixed, the building received very low thermal comfort and thermal control satisfaction scores in our survey, and it is unclear whether these responses have to do with the legacy of the first summer, ongoing issues, occupant attitudes, or a combination. Currently, the building operates with tighter set-points than in the initial design. Almost all areas are operated to a heating setpoint of 68-70°F heating during the winter, and 72-74°F cooling setpoint during the summer.

Occupant Response

Survey results for Orinda City Hall showed the highest percentage of survey respondents reporting "never" responding to the signals as well as being "very likely" to open the window if they want to, regardless of the sign. There are a number of circumstances that probably compound to produce these results. First, the green film used in the sign is fairly luminescent, and it can be hard to tell if the signs are on or off. Secondly, transom-level windows rarely get used and doors are often closed, which removes the notion that the windows benefit the building generally. Finally, there is very little social reinforcement of the type observed in other buildings in this study, which can be a function of interest level (architects, environmental researchers), office layout (big spaces shared by many people), and/or a coordinated education effort. There was an initial orientation and information card prepared for occupants and ongoing sporadic efforts by the building manager, but comfort issues early on may have produced a general apathy. During a site visit I perceived an attitude that the "open windows" signs are a nice idea, but more of a "green" gesture than something that is informative or otherwise of benefit to one's daily routine.

15. . Boora Architects Offices, Portland, OR

Group 5 Decoupled cooling and ventilation

Project Scope	Major LEED renovation of top floor in historically significant building, designed by tenants
Architect	Boora Architects
Mechanical Engineer	Arup
Year Completed	2008
Perimeter Program	Small open office, 2 workstations deep
Occupants	50

Intent of Signals

To lend visibility to the building's original design, so that comfort is maintained without ducted air supply and cooling energy is minimized. "Open Windows" signs illuminate when outdoor temperatures are within 62° and 80°.

System Description

When Boora was looking to expand and modernize their offices, they decided to remain on the top floor of a historic multi-story building, and undergo a renovation that would return the building to its original design and provide an example to other tenants. A reconfiguration of the office space into perimeter open workstations accompanied the replacement of mechanical equipment and the installation of daylighting controls and ceiling fans. The building is heated and cooled by a three-pipe hydronic system with perimeter fan-coil units. Occupants can manually change the temperature and fan settings of their units, and a central building management system turns off the fans at 6 pm every day to save energy. Because the tenants could not remove the cooling system altogether, they had to find a way to remind staff to take advantage of their windows and discourage using windows and cooling units simultaneously. One "open windows" sign is installed in the center of each office wing, and it is individually wired to an outdoor temperature sensor and indoor thermostat, making the controls the simplest and most legible among buildings in the study.

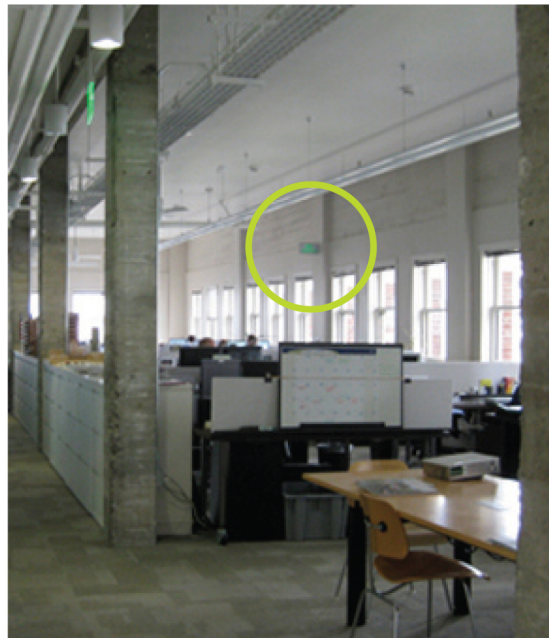

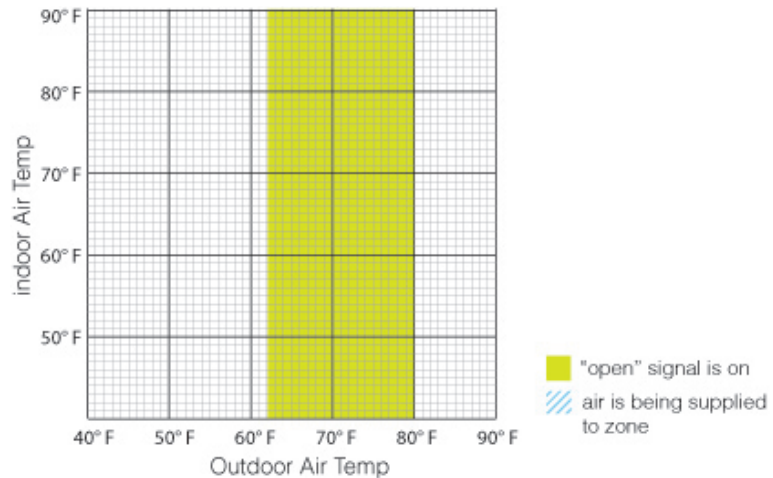

Occupant Response

Indoor environmental quality satisfaction is very high according to our survey. Similar to ZGF Architects (Group 1) and NBBJ Architects (Group 4), this project benefits from an occupant group that is very well-informed and positive about their space. The biggest issue noted by occupants is the tendency for the signs to go un-noticed because of their location (half the people on each wing face away from the sign), and their similarity to the exit signs. The next most common comments refer to unique personal temperature preferences, reports that the signs go on when conditions are either warmer or cooler than certain individuals would choose. A few people also commented that fresh air and air movement should be taken into account.

Based on these comments and interviews with the design team, there are two aspects of the system that could be refined. First, given their location on the 8th floor in a downtown area, the acceptability of the temperature set-points depends a great deal on wind, which isn't taken into account. Secondly, because the mechanical systems have already been downsized, further energy reduction opportunities may require staff education regarding the control of their fan-coil units and ceiling fans, rather than a focus on the windows alone. Overall, because the project is such a simple and successful application of signaling systems, it provides a unique opportunity to study how different educational strategies or adjustments to the control algorithms can maximize participation or reduce cooling energy.

16. Compton Union Building, Washington State University, Pullman, Eastern WA

Group 5 Decoupled cooling and ventilation

Project Scope	Major renovation and modernization of 1950s 250,000 s.f. student union building with original operable windows
Architect	Pfeiffer Partners, Integrus Architecture
Mechanical Engineer	WSP Flack and Kurtz
Year Completed	2008
Perimeter Program	Private and shared enclosed offices
Occupants	24

Intent of Signals

To remind people to use their windows for ventilation and to keep them closed above 76 F for maximum cooling benefit.



photo courtesy: Tim Griffith photographer



photo courtesy: Integrus Architecture

Casement-type operable windows are available to the small office space on the 4th floor.

System Description

The original 1950s building was designed to depend on a large central air-handling system. The goal during the renovation was to open up the building by reducing ductwork and relying on radiant heating and cooling where possible. Once it was determined that staff liked having operable windows, they were retained in office spaces and combined with radiant panels for the perimeter offices, reducing fan energy from 100 to 20 cfm/person. A set of green and amber lights are placed in common/circulation areas near the offices. Both the lights and the cooling system operate based on outdoor air temperature. Above 76, the cooling system does a better job at keeping people comfortable, so it goes on and people are told to keep their windows closed for maximum benefit.

Operating Conditions

The green mode range, originally designed to be 60-77 F, was adjusted by campus controls staff to 71-77 F, which is closer to the indoor temperature setpoint range. The building manager wasn't sure why this was done, probably because 60 F seemed too cold an outdoor temperature to let in. A potential consequence is that indoor



We were unable to collect images of the offices or the lights. This is a similar indicator used in a different project by the engineer.

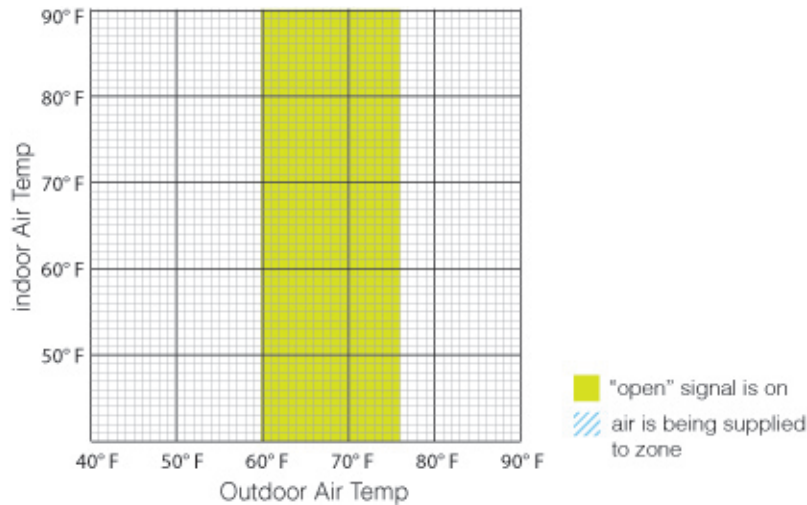

air temperatures might reach the 76 F sooner than they would otherwise, depending on the balance point of the building.

Occupant Response

Without having visited the building, there are not enough survey comments to get a clear picture of what conflicts are most common, but it seems that the signs are more likely to go unnoticed in this building than others both because of their placement and a lack of internal policy/reinforcement. This building has the largest percentage of “dismissive” comments, including the “I dont’ pay attention” as well as “i do what I want.” Three out of ten total comments noted fresh air as a main reason they open the window regardless of the lights. One respondent said that the light was counter-intuitive; that the light has been red when it could be green.