

UC Berkeley

Cross-Currents: East Asian History and Culture Review

Title

Triangulating Chōsen: Maps, Mapmaking, and the Land Survey in Colonial Korea

Permalink

<https://escholarship.org/uc/item/60z4p2nk>

Journal

Cross-Currents: East Asian History and Culture Review, 1(2)

Author

Fedman, David

Publication Date

2012-03-01

CROSS-CURRENTS



EAST ASIAN HISTORY AND CULTURE REVIEW

Triangulating Chōsen: Maps, Mapmaking, and the Land Survey in Colonial Korea

David Fedman, Stanford University

History records many foolish notions regarding the shape of the earth. Although it is stated that Pythagoras and Thales taught that the earth is spherical, their teaching was without avail, as for nine centuries the shape of the earth was the subject of all kinds of theories.... The triangulation and the astronomic observations.... made by the United States Coast and Geodetic Survey furnish the most valuable data for the determination of the figure of the earth that have been contributed by any one nation. *Each civilized nation maintains an organization for similar purposes.*

—Edward Richard Cary, *Geodetic Surveying*, 1916 (emphasis added)

Abstract

Drawing from an assortment of government reports, contemporary publications, and cartographic materials, this article examines the triangulation survey conducted by the Japanese government-general in Korea from 1910 to 1918. In addition to elucidating the mapmaking process, it explores the ways in which the triangulation survey both reflected and promoted Japan's colonial authority in Korea and abroad. By turns, the author provides a broad sketch of the planning and implementation of the survey, considers the tools and techniques that enabled it, traces the progress of the triangulation enterprise, and dwells on the legacy and limitations of the maps brought about by the triangulation survey.

Introduction

On September 21, 1909, the delegates to the sixteenth conference of the International Geodetic Association (IGA) assembled in the lecture room of the Institution of Civil Engineers in Westminster, London for a busy day of “presentations of Reports of geodetic work of various kinds done in different countries” (Helmert 1909, 375). Covering a broad sweep of topics and geographical terrain, the day's proceedings included a discussion of the potential linkage of the triangulation surveys of India and Russia via the northern frontier of the Himalayas, a

presentation on “the comparative merits of Invar wires and tapes for the measurement of base-lines,” and a progress report on the International Latitude Service, which was then hard at work consolidating the measurements of longitude and latitude provided by each participant nation. If the outlook of one observer, F. R. Helmert, is representative, the mood at the conference was marked by pride and optimism. “The efforts of the International Geodetic Association,” he wrote, “are...crowned with success in reducing to quite a small quantity the uncertainty in the form and dimensions of the Earth” (1909, 377).

Though perhaps oversized, Helmert’s confidence was not unfounded, for the geodetic sciences—those concerned with the measurement and mapping of the earth—were then in the midst of a veritable boom brought about by a host of scientific advancements. None of these advancements inspired more excitement or commanded more international attention than the triangulation survey: a mapmaking technique that, though old by the time of the 1909 conference, offered a level of precision previously unimaginable when coupled with the cutting-edge surveying instruments of the time. Not surprisingly, the IGA was at the vanguard of the international triangulation project. Founded in 1886 for the purpose of “forming an association through which the geodetic work carried on by various governments could be compared, harmonized, and rendered more efficient,” this body quickly established itself as the international hothouse for scientifically rigorous cartography.¹ Although standardizing the methods of mapmaking was not an explicit goal of the IGA, one contemporary expert commented that by “virtue of the active interchange of ideas” the body “exert[ed] a strong influence in making the methods used in various countries more nearly uniform and progressive” (Reinsch 1911, 68). This is especially true of the tools and techniques of the triangulation survey, which dominated the 1909 agenda.

If triangulation dominated the content of the 1909 conference, the world’s colonial powers (namely Great Britain, France, Germany, Russia, and the United States) dominated its composition. This is in no small part because, as this paper will show, colonialism and cartography were deeply intertwined undertakings. Scientifically rigorous maps, after all, were the lingua franca of international sovereignty, making them a sine qua non for the acquisition of and authority over colonial territories. Indeed, whatever the differences in the colonial policies and ambitions of the so-called Great Powers, all of these nations shared an awareness of the

instrumental role that cartographic knowledge played in the imperial project. As such, these nations often dispatched their brightest cartographic minds to their colonies, where they oversaw the production of cutting-edge maps, most of which were realized through the triangulation survey. One need only inspect the list of delegates to the 1909 conference to gain a sense of the close ties between the geodetic sciences and colonialism. Among those present were Colonel Sir W. Morris, chief surveyor of Great Britain's Geodetic Survey of South Africa; Major Lenox-Conyngham, then director of the Great Triangulation Survey of India; General Bassot of France, then president of the association and formerly a chief surveyor for the French Geodetic Survey in Algeria; and many others (Helmert 1909, 375).

Lesser known among these delegates was Terao Hisashi (1855–1923), one of Japan's preeminent astronomers and then chairman of its Imperial Geodetic Committee. Although his contributions to the conference remain obscure (his name appears sparsely in the proceedings), his presence was significant. As the first director of the Tokyo Astronomical Observatory, the first dean of the Tokyo College of Science, and the chief executive responsible for the development of land-surveying techniques in Japan, Terao knew better than anyone the credence that the geodetic sciences lent to Japan's status as a first-rank nation (*ittō koku*), one entitled to its colonies (Nakagiri 2009). This sentiment, of course, was not peculiar to Terao: the Japanese government had in fact moved early and vigorously in its pursuit of scientifically rigorous maps.² By 1909, on the eve of Japan's annexation of Korea, Japan had already established an impressive network of surveying schools, trained a cadre of professional surveyors, completed a triangulation survey of the Japanese archipelago, and conducted a land survey of Taiwan (Kobayashi 2011). That Japan was the only Asian nation present at the 1909 conference bespeaks its energetic pursuit of and contributions to the geodetic sciences. And just like the Great Powers that sat at the helm of the IGA, Japan was quick to dispatch its surveyors to its colonies. Embedded within military units, engineering projects, and colonial governments, these surveyors firmly established themselves as vigorous contributors to Japan's imperial project. With a compass in one hand and field glasses in the other, these mapmakers stood at the front lines of the empire.

Like railroads, telegraphs, and guns, maps were tools of empire (Addas 1990; Bayly 2000; Headrick 1981; Mitchell 2002; D. Yang 2011). Indispensable to governance, surveillance,

resource extraction, and countless other imperial initiatives, maps formed the lifeblood of the day-to-day operations of the colonial state. But the impetus behind colonial cartography was more than simply utilitarian, for, as a growing number of scholars have shown, the process of surveying was as important as the product (Atkins 2010; Burnett 2000; Edney 1990; Harley and Laxton 1998; Pratt 1992). The survey, after all, made for good science. And science, pregnant as it was with notions of civilization, development, and material progress, sat squarely at the heart of the imperial project. Statistics, blueprints, ethnographies: all formed building blocks upon which Japan's civilizing mission in Korea would be constructed (Henry 2006; Oh 2008). Maps were no different. Cloaked in the mantle of scientific precision, the triangulation survey served to showcase Japan's superior methods. The observations of Norbert Weber, a Benedictine monk who traveled to Korea in 1911, testify to this point: "At each instrument stand," he wrote, "three to four assistants and a crowd of wondering spectators, who gather in wonder at the undreamed of science no less than at the instrument with its pipes and glasses and spirit levels. What a great pleasure it must be for the local Japanese surveyors to be able to put their science on show like this" (Uden 2003, 58). As some of the first government-general employees to set foot in remote towns, moreover, land surveyors—who were sometimes accompanied by local police and officials—became for many Koreans the face of Japanese officialdom.

It is not hyperbole to state that the history of Japanese colonial cartography is terra incognita for English-language scholarship.³ While scholars writing in English have become attentive to the ways in which Japan immersed itself in the conventions of international law (Dudden 2004), criminal procedure (Botsman 2005), and other hallmarks of the modern nation-state (Ericson 1996; Frühstück 2003; Walker 2005), few have explored the ways in which it sought out and appropriated international cartographic norms. Fewer still have attended to the ways in which maps and mapmakers figured into Japan's administration of its colonies. In the case of Korea, only the cadastral survey (of which more later) has garnered significant scholarly attention, and existing studies maintain a laser-like focus on issues relating to the expropriation of Korean land by the government-general and settler colonialists. The geodetic aspects of Japan's land survey of Korea, as a result, have received precious little scholarly attention, despite a growing body of literature addressing mapmaking and imperialism in other colonial contexts (Bassett 1994; Edney 1990; B. Harley 1989; Mitchell 2002; Mundy 2000; Scott 1999; Thongchai

1994) and substantial literature on the subject in Japanese and Korean (in Japanese, Kobayashi 2009, 2011; Miyajima 1991; Takagi 1966; in Korean, Han'guk Yōksa Yōn'guhoe 2010; Kim 1997).

Taking colonial Korea as a case study, this article seeks to shed light on the methods, tools, bodies, and rhetoric employed by the Japanese state in its effort to produce cartographic knowledge of its colonies. The analysis proceeds in four phases, beginning with a broad overview of the planning process undertaken by the Provisional Land Survey Bureau (*Rinji tochi chōsa kyoku*; hereafter Land Survey Bureau) commissioned by the government-general of Korea (*Chōsen sōtokufu*). This overview provides a rough sketch of the triangulation survey as it fits within the larger cadastral survey project. Second, the article describes the methods and tools employed by the surveyors, and traces in broad strokes the progress of the survey from its commencement to its closing. A third section explores the physical construction of the maps, while the concluding section considers the limitations and lacunae of these maps and, more generally, the relationship between mapping, state-led development, and power in the colonial context.

Planning the Land Survey

The triangulation survey initiated in 1910 was not the Japanese government's first attempt to survey the Korean peninsula. As Yamachika Kumiko (2011) and Kobayashi Shigeru (in this volume) have shown, by the time of Korea's annexation in 1910 the Japanese had already amassed a rich body of cartographic materials through an assortment of commercial, military, and covert intelligence gathering. The greatest boon to mapmaking in Korea undoubtedly came with the First Sino-Japanese War (1894–1895) and the Russo-Japanese War (1904–1905), which spurred the systematic production of maps of Korea's interior. In contrast to the spotty nature of the coastal hydrographic surveys and covert travel surveys that yielded the earliest maps of fin-de-siècle Korea, the strategic military maps (*ryakuzu*) generated by these military campaigns provided a standardized and high-quality representation of much of the peninsula—one of use not only to the military but also to the government officials and colonial bureaucrats who were making their way to the peninsula in ever-increasing numbers (Kobayashi 2009, 2011; Nam 1997; Takagi 1966; Unno 1997).

Japan's establishment of a protectorate in 1905 opened the door to new cartographic possibilities. Indeed, with its political influence on the peninsula growing and the trickle of Japanese settler colonialists turning into a flood, the Japanese government's mapping agenda began to change. Although a wide array of cartographic plans were considered during this period, no mapping project was more eagerly pursued by Japanese administrators than the cadastral survey: a comprehensive land survey designed to produce a standardized set of land registers and accompanying maps that would ascribe ownership to every parcel of Korea's soil. Unlike previous surveys of strategic sites (e.g., conflict zones, port towns, major roadways, and so forth), this was to be a truly nationwide cadastral survey, one that would dispatch mapmakers and land surveyors to every corner of the peninsula. The changing political priorities of the government-general, the perceived need for tax reform, and the numerous development projects already under way in Korea demanded a synoptic view of the Korean landscape, and the cadastral survey provided just that.

The staunchest advocate for the cadastral survey came in the person of Megata Tanetarō (1853–1926), who served as a special financial advisor—effectively auditor-in-chief—in Korea from 1904 to 1907. Having overseen similar surveys in Okinawa and Taiwan, Megata was acutely aware of the importance a thorough cadastral survey held for the “rationalization” (*gōrika*) of taxes and economic development. At Megata's behest, the planning of the cadastral survey began in earnest in 1907 under the purview of the Department of Finance. In 1908, the Korean government took out an “undertaking loan” of approximately seventeen million yen from Europe in order to fund the survey, and it proffered a budget proposal that allocated funds for the roughly seven years that planners estimated the survey would take. Although bureaucratic inertia and more pressing political initiatives (such as the suppression of anti-Japanese guerilla fighters) held back the survey for two years, administrators continued to hammer out the logistics of the operation, using similar surveys conducted in India, Okinawa, and Taiwan as their models (Gragert 1994; Kobayashi and Kunitada 2007). During this period cartographers also began to prepare the base maps for the survey, a bulk of which were set at the scales of 1:50,000 and 1:25,000 (although other ratios were produced). This initial office work set out to prepare a basic skeleton of spatial information (e.g., latitudinal and longitudinal coordinates and basic toponyms) so that the surveyors could fluidly affix their measurements onto each original map sheet once

the measurements started pouring in to field offices and drafting stations (Rinji tochi chōsa kyoku [hereafter RTC] 1918, 454–455).

Shortly after annexation in August 1910, the government-general commenced the land survey. The work of the survey was handed over to the newly established Provisional Land Survey Bureau of the government-general, which assumed all responsibility for its operations. The official regulations of the land survey were set forth in Imperial Ordinance No. 361, codified in September 1910, just weeks after the Treaty of Annexation was inked. “A complete land survey of Korea,” stated a government-general report from 1910, “is of great importance in order to secure justice and equity in the levying of the land tax, and for accurately determining the cadastre of each region as well as protecting rights of ownership and thereby facilitating transactions of sale, purchase or other transfers. Otherwise, the productive power of land in the Peninsula can not be developed” (Government-General of Korea [hereafter GGK] 1911, 40). For the government-general, the land survey was thus the key to unleashing the productive power of Korean soil, and standardized maps—those that fashioned order out of perceived chaos (Scott 1999)—were the canvas upon which a new, rational, and productive Korea would be drawn.

No single individual contributed to the day-to-day management of the cadastral survey more energetically than Tawara Magoichi (1869–1944), the career bureaucrat appointed vice president of the Temporary Land Survey Bureau in 1910 and later selected as the director of its operations. Tawara was soon joined by a cadre of surveying experts from Japan’s Land Survey Department (*Rikuchi Sokuryōbu*), many of whom had cut their teeth mapping other parts of the Japanese empire. According to the official account, these surveyors “brought years of experience” (*tanen shigyō no keiken o yū shi*) and “progressive” surveying techniques (*saishinpō seru mono*) with them to the peninsula (RTC 1918, 453). A small group of Korean surveyors, many of whom were involved in the ex-Korean government’s Kwangmu land survey (1898–1903), were also folded into this operation, as were fragments of the organizational and operational infrastructure of this earlier surveying enterprise (Gragert 1994) (see figure 1).

Although secondary to the cadastral process, the triangulation survey of the peninsula was nevertheless a vital part of the work of the Land Survey Bureau. Without maps fixed to a grid of longitudinal and latitudinal coordinates, Japan’s efforts in Korea would remain detached from the geodetic grid of the international system, yielding maps not only of questionable

Figure 1. A surveying party gearing up for a day of fieldwork. Source: GGK (1911, 40).



accuracy but also utterly unimpressive by international standards. If former foreign minister Aoki Shūzō's 1890 recommendation that "Korea should be made a part of the Japanese map" (Hastings 1988, 24) expressed an abstract political goal, the process of triangulation provided the means to, quite literally, do just that. On a more practical level, the triangulation survey also provided the broader picture for surveyors and administrators alike: the base layer of spatial measurements against which more specific calculations (such as the cadastre) could be referenced. "Based on the process of triangulation," stated a report on the triangulation process, "the survey can schematically render land form and composition," making it possible for these surveyors to enhance the cadastral process and reduce error considerably (RTC 1918, 456). Both projects, in other words, were entwined: while cadastral investigators worked their way systematically from hamlet to hamlet and property to property, demarcating the boundaries and valuation of fields along the way, the geodetic survey section carried out a painstaking series of measurements to enable the consolidation of these individual plots onto one systematic spatial grid.

The early institutional composition of the Temporary Land Survey Bureau nicely reflects these twin cartographic imperatives. As of 1911, the bureau was comprised of 835 individuals, of

which 678 were engaged chiefly in land surveying: one as the chief surveyor, ten as inspectors, four as expert surveyors, and 661 as assistants (Unno 1997, 66). The bureau consisted of four primary sections: a general affairs section, which oversaw the political and administrative work of the survey; an investigation section, which conducted cadastral fieldwork; a survey section, which was charged with the production of maps through a variety of methods; and the land survey detached offices, which essentially served as local branch offices and data processing centers for the entire enterprise. A 1911 government-general report describes the division of labor as follows: “While the investigation section principally deals with investigating matters concerning ownership, location, boundaries, and also the compilation of reports of investigations, register books, etc., the survey section is charged with carrying out surveys by primary triangulation, secondary triangulation, plat survey and other measurements of lands, and with compiling maps of the districts surveyed” (GGK 1911, 42). The Land Survey Bureau had also by this point established a small number of training schools where it undertook the recruitment and training of Korean and Japanese surveyors who would contribute to the survey in myriad ways, as discussed below.

The Surveyor’s Fieldwork

To monitor the planning, commencement, and implementation of the land survey in Korea, one need only turn to its daily newspapers. Both the Japanese-language *Keijō Nippō* and the Korean-language *Maeil Sinbo* ran a steady stream of articles on the land survey from its commencement in 1910 through its conclusion in 1918. Although terse, these articles offered a wide range of information on the survey—from its rules and regulations to its objectives, from the composition of its board of directors to the movements of its surveyors (*Keijō Nippō* 1910, 1918; *Maeil Sinbo* 1911, 1918). So, too, did the monthly magazine *Chōsen* (which ran from 1908 to 1912 and was later rebranded as *Chōsen oyobi Manshū*), which in its July 1910 edition offered the following account:

.... the first step in the sequence of the survey is the establishment of signal stations between Tsushima (*Taishū*) and Pusan in order to establish baselines (*honsen*) that will connect with...signal stations already established in the vicinity of Keijō...Surveyors, who number approximately 160, will break into twenty smaller parties, five of which will oversee the preparation and collection of land

registers while the other fifteen, comprised of roughly 100 members, will undertake a detailed investigation (*shōsai no chōsa*) of these land plots (*Chōsen* 1910, 111).

The highly visible nature of the survey is exactly what administrators wanted. For the entire cadastral survey enterprise was predicated upon the willful participation of Koreans, making it imperative that Koreans understand the procedures of the survey and the movements of its surveyors.⁴ It was not uncommon, in fact, for land investigators to deliver public addresses on the objectives of the survey and to post public bills that described the process (Miyajima 1991; Wada 1967).

Official documents on the movements of the triangulation surveyors are fragmentary, but a patchwork of government-general reports and the research of Japanese and Korean scholars provides a rough sketch of their earliest activities. As the above passage from *Chōsen* suggests, one of the first actions of the triangulation survey was to establish a geodetic linkage between Korea and Japan by way of Tsushima, an island that sat squarely between the peninsula and the archipelago. A government-general report from 1911 stated:

In order to connect the geodetic triangulation of Japan proper with that of Korea, based upon the selection of principal points of triangulation in *Tsushima* island, Japan proper, the longitude and latitude of *Zetsuyei* (Chyōlyōng) island (near *Fusan*) and *Kyosai* (Kō-jyō) island (near *Masan*) in the extreme South of the Peninsula, and the distance between the two islands were surveyed (GGK 1911, 43).

Dryly technical though this statement might sound, it is hard to overstate its importance. As one of the first measurements taken by the surveyors, this geodetic linkage marked a critical step in Japan's effort to orient Korean space to the same spatial matrix as the Japanese homeland, and thus into alignment with Japan's own cartographic conventions. So it was that the former trading post of Tsushima became a cartographic linchpin of the Japanese empire.

As was standard practice, the lion's share of the surveyors' earliest efforts were devoted to two things: reconnaissance surveys and the construction of the baselines for the triangulation survey, the first two of which were determined in Ch'ungch'ōng and Kyōnggi Provinces. Essentially imaginary lines of measurement strung across a series of elevated points, these baselines formed the spine (or "primary system") of the survey to which all other measurements

would refer. The construction of a baseline was no easy task. Climbing a peak and establishing an unimpeded line of sight (which sometimes meant felling trees that stood in the way) demanded tremendous patience and physical strength. It also demanded the assistance of numerous Korean porters and guides, whose knowledge of local terrain was invaluable to the reconnaissance surveyors. Particularly painstaking was the erection of observation stations, some of which were massive in scale, on hilltops and mountain peaks so that surveyors could measure, using a theodolite, the distance from signal station to signal station, a string of which would form a baseline (see figure 2).

Figure 2. Surveyors constructing a signal pole atop a Korean peak. Source: GGK (1911 40).



Although the surveyors had at their disposal an impressive toolbox of equipment, no piece of hardware was more important than the theodolite (see figure 3). A moveable telescope mounted on two axes, the theodolite was used to measure angles in both horizontal and vertical planes. Japanese surveyors in Korea employed a modified theodolite known as a transit, which, as a result of numerous innovations and fine-tuning, reduced error considerably. Of particular

importance to the measurement recorded for primary triangulation was the Bamberg Transit: a state-of-the-art telescope that was put to the test in Korea. Equipped with advanced striding levelers and micrometer eyepieces, it provided for a previously impossible level of accuracy and quickly became a mainstay of Japanese surveying (Kobayashi 2011).⁵

Figure 3. An illustration of a theodolite. Source: Hayashi (1936, 22). Courtesy of The National Library of Korea Digital Archive.

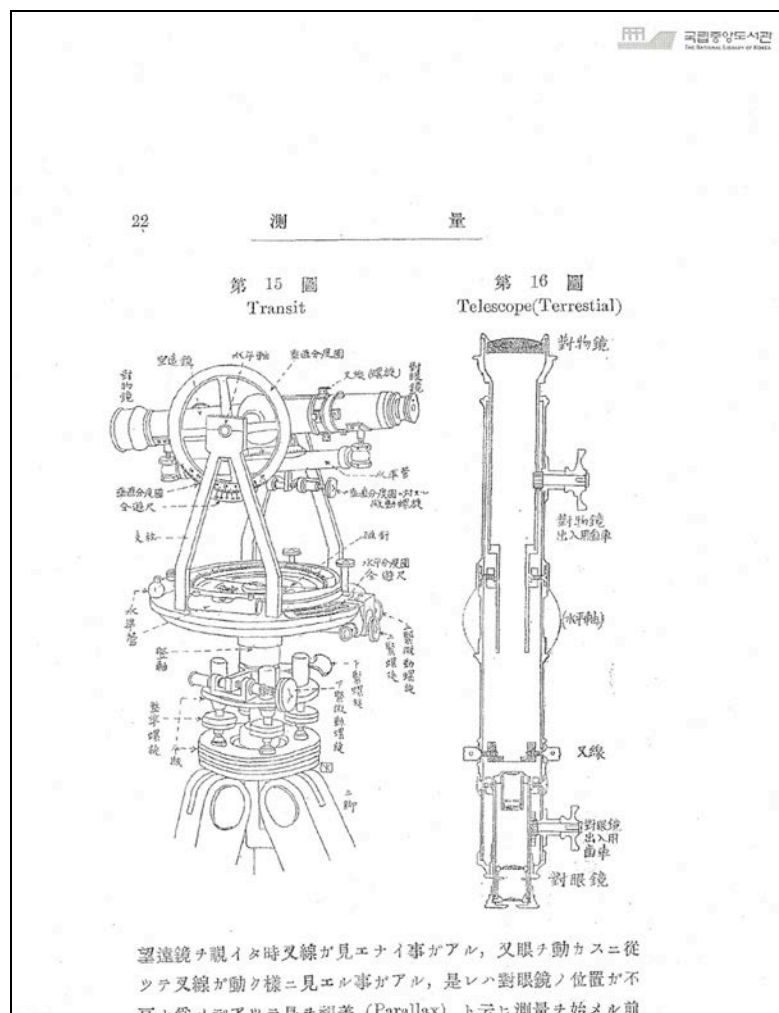

The baselines constructed by Japanese surveyors ranged from two thousand to forty-six-hundred meters in length, and were constructed in most cases along the spine of Korea's many mountain ranges. Initially, surveyors divided the peninsula into fifteen triangulation nets: subdivisions of the peninsula, determined by its natural topography, that parceled out the

triangulation process into smaller, locally contained units, all of which would eventually be aligned once enough data was collected. By the end of 1910, the surveyors had successfully constructed six baselines. By March of the following year they had established an “aggregate operative zone” of nearly seven thousand square *ri* in area and brought the number of baselines up to ten, which then cut through North and South Kyōngsang, Ch’ungch’ōng, South Chōlla, and North and South P’yōngan Provinces. Taken together, these baselines amounted to 11,327 meters in length (GGK 1914, 21). In 1912, with the surveying of the principal points of the geodetic or primary triangulation under way in all of Korea’s provinces except for the remote North Hamgyōng, the surveyors constructed three additional baselines, bringing the final number to thirteen. By 1913, primary surveys were under way in every province in Korea, and by some official estimates the primary triangulation survey would be completed by 1914 (GGK 1915, 10).

The erection of signal poles and the measurement of baselines was only the first step in a long and laborious set of measurements, however. The filling in—or “densification,” in surveyors’ terms—of the so-called triangulation nets formed the next step in the surveying process. Although far more complex than will be described here, this process entailed the painstaking execution of secondary triangulation surveys (or plane trigonometric surveys) and leveling line surveys, whereby surveyors would record measurements of vertical and horizontal angles over a much smaller area in order to calculate the position of smaller nets relative to the larger system (RTC 1918, 456–458). When compared to the primary system of triangulation, secondary surveys were less precise, but they did serve to enrich these maps with additional data points—all of which, crucially, were in reference to the primary system of triangulation (see figure 4). As more of this data poured into the processing centers, which were at this point scattered across the peninsula, mapmakers began to weave together a tighter web of spatial data—one that would eventually form the cartographic foundation upon which a diverse array of geographic information would be laid.

Once the primary systems of triangulation had been constructed, secondary or “subsidiary” observation and theodolite traverses (which were vital for plat surveys of cadastral holdings) became the central focus. The changing composition of the Land Survey Bureau’s personnel nicely reflects this shift. In early 1911, when the bureau was engaged chiefly in the construction of baselines and the measurement of a few foundational data points, it employed

Figure 4. A visualization of a typical triangulation net. Note the multiple scales and systems of measurements. Source: Hayashi (1938, 95). Courtesy of The National Library of Korea Digital Archive.

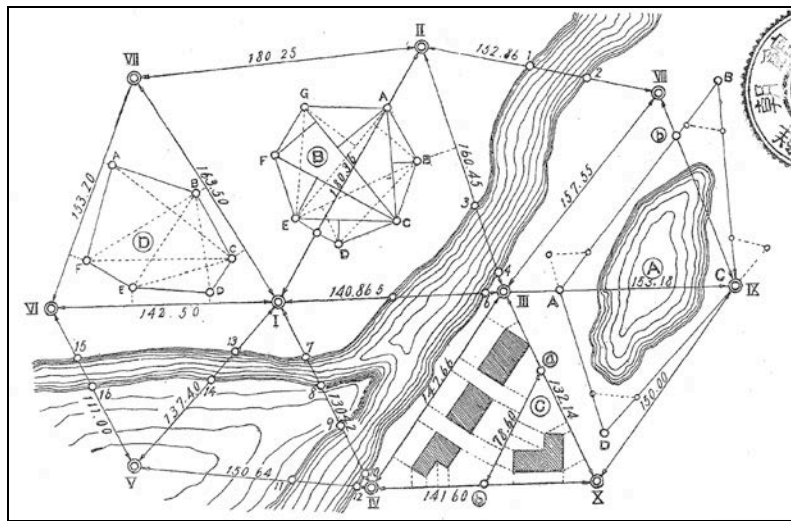

678 employees, of whom only a handful were surveying professionals (Unno 1997). By 1912, however, the bureau had changed markedly. In order to cope with the demands of theodolite traverses, secondary surveys, and the data processing necessitated by both, the total force of the bureau was increased to 2,253. Significantly, of this total work force, approximately 1,750 were Koreans, most of whom served as elementary surveyors, field assistants, porters, and clerks. The Land Survey Bureau also expanded its bureaucratic structure: in 1912 it opened up additional field offices, established an engineering section and a planning section, and increased the faculty and students at its training schools, which were then attached to several high schools in Keijō and a number of agricultural schools in other provinces (GGK 1914, 20).

The surveying priorities of the Land Survey Bureau were also often determined piecemeal by the engineering and construction projects under consideration by other agencies of the government-general. Accurate maps were essential planning documents for a wide range of public works project (dams, irrigation canals, and railroads chief among them), meaning that surveyors often had to shift their sights to the regions deemed of strategic importance to the colonial government and its planners. The construction of railroads and irrigation channels, in particular, shaped the agenda for surveyors, many of whom worked in concert with bureaucrats and planners. It is also noteworthy that the triangulation survey was far from the only mapmaking project under way on the peninsula during this time: a host of other surveys were

being conducted, many of them under the direction of other colonial agencies. The Forestry Bureau (*Sanrinkyoku*), for example, was mapping Korea's forests, while the Bureau of Agriculture, Commerce and Industry (*Nōshōkōbu*) was contemporaneously conducting a series of geological surveys concentrated in the mineral-rich areas of the northeast (Hagino 1965; McCune 1946; Nam 2006).

The year 1915 marked not only the peak in the size of the Land Survey Bureau's operations (which capped at 4,713 employees) but also an important transition in the triangulation survey. With primary triangulation for the most part achieved and a group of surveyors filling in the triangulation nets with additional data (with one estimate stating that the survey had completed roughly 22 percent of its triangulated maps), the Land Survey Bureau shifted its gears to enriching its topographical maps (RTC 1918, 468). Indeed, while mapmakers by this point may have received an impressive set of rigorously calculated spatial coordinates to inscribe onto the map, they had little in the way of topographical and geographical detail. The next major phase of the land survey was thus chiefly concerned with the mapping of an array of additional geographical features, such that the maps produced could convey the physical relief of the landscape. Around this time the Land Survey Bureau also ramped up its hydrographic surveys, which sought to map Korea's waterways, seabed, and coastline.

By the end of 1916, the Land Survey Bureau had nearly completed its primary triangulation, secondary triangulation, leveling line, and theodolite traverse surveys of the peninsula. While follow-up surveys and map revisions continued well into the 1920s, the surveying work slowed down considerably. The Land Survey Bureau downsized its operation accordingly, relieving 102 Japanese officials and 1,654 Korean employees of their duties (GGK 1918, 152). Some of the surveying experts were dispatched elsewhere in the empire, such as Manchuria, where they would oversee other mapmaking projects. Although it would be another two years before the triangulation survey would formally shut down its operations, the fieldwork component of the survey was for the most part complete. This does not mean, however, that the maps were complete, for the surveyor's fieldwork was only one part of a much larger operation. It remained for this outfit to process the data, draft the maps, and publish the finished product—what many documents aptly describe as the Land Survey Bureau's "indoor work" (*naigyō*) (RTC 1918, 469).

The Mapmaker's "Indoor Work"

It goes without saying that the process described above was heavy on computation. Indeed, whatever the sophistication of the tools and techniques employed by the surveyors, their maps were only as good as the trigonometric computations made by the mapmaker, which were nothing if not voluminous. The records of the Land Survey Bureau in fact overflow with trigonometric calculations and equations, and the library maintained by the Land Survey Bureau in Korea includes countless academic treatises on the subject. One such guide, *Sokuryō* (Surveying), a widely referenced manual on the geodetic sciences, discusses at great length the myriad trigonometric principles employed in triangulation. Perhaps most interestingly, this work also reveals, through its many citations, the myriad foreign-language works that formed the intellectual foundation of this surveying operation: Gillespie's *Treatise on Surveying I and II*, Weitbrech's *Lehrbuch der Vermessungskunde I and II* (Textbook of Surveying), and Breed and Hosmer's *Principles and Practice of Surveying I and II*, among others (Hayashi 1936, 1).

The principal challenge lay in translating data points into a map projection. As data poured into the processing centers (see figure 5), a cadre of employees worked to sort out this data in a timely and fluid fashion. Although Korean employees were more often tasked with filing the cadastral registers, they also contributed to the calculation component of the triangulation project, mostly as clerks. In the early stages of this operation, the draftsmen and professional cartographers were, with a few exceptions, Japanese.

Once a sufficient amount of data had been acquired for each map sheet, draftsmen moved forward with a multistep process that involved the construction of a projection, the plotting of data points onto the map grid, the sketching of contour lines to convey topography, the demarcation of geographical points of interest through the representational code established in the map legend, and, perhaps most vexing of all, the inscription of toponyms, rendered with Japanese glosses (RTC 1918, 459–465). After numerous revisions, some of which necessitated further surveying and new data points, the map was near completion. Once a draft was approved it was printed and, depending on its security classification, sent to administrators and military officials who quickly put it to work (RTC 1918, 469). The first round of seventy-nine map sheets was printed in 1915; an additional 157, 261, and 242 sheets were printed in 1916, 1917, and 1918 respectively (RTC 1918, 469).

Figure 5. Employees of the Land Survey Bureau hard at work. Source: GGK (1915, 11).



Two particular features of the finished product merit further consideration. The first is the fact that the triangulation process is visually etched onto the map. Figure 6, for example—a 1:50,000-scale map of Kwakchi, an area in northwestern Cheju Island (selected precisely because of its ordinariness)—reveals a web of primary triangulation, secondary triangulation, and leveling points. These points are coded into the map legend, as figure 7 shows, making it possible for the map reader to trace and pinpoint the movements and measurements of the surveyors. Close inspection of the triangulation points inscribed onto each map thus allows for something of a deconstruction of the mapmaking process (see figure 8). Although embedded within multiple layers of coding and imagery, these points form the anchor points of the map—the primary system of measurement that brought the cartographic project to fruition.

Figure 6. A 1:50,000-scale map of Kwakchi. Drafted in 1916; printed in 1918. Courtesy of Branner Earth Sciences Library, Stanford University.

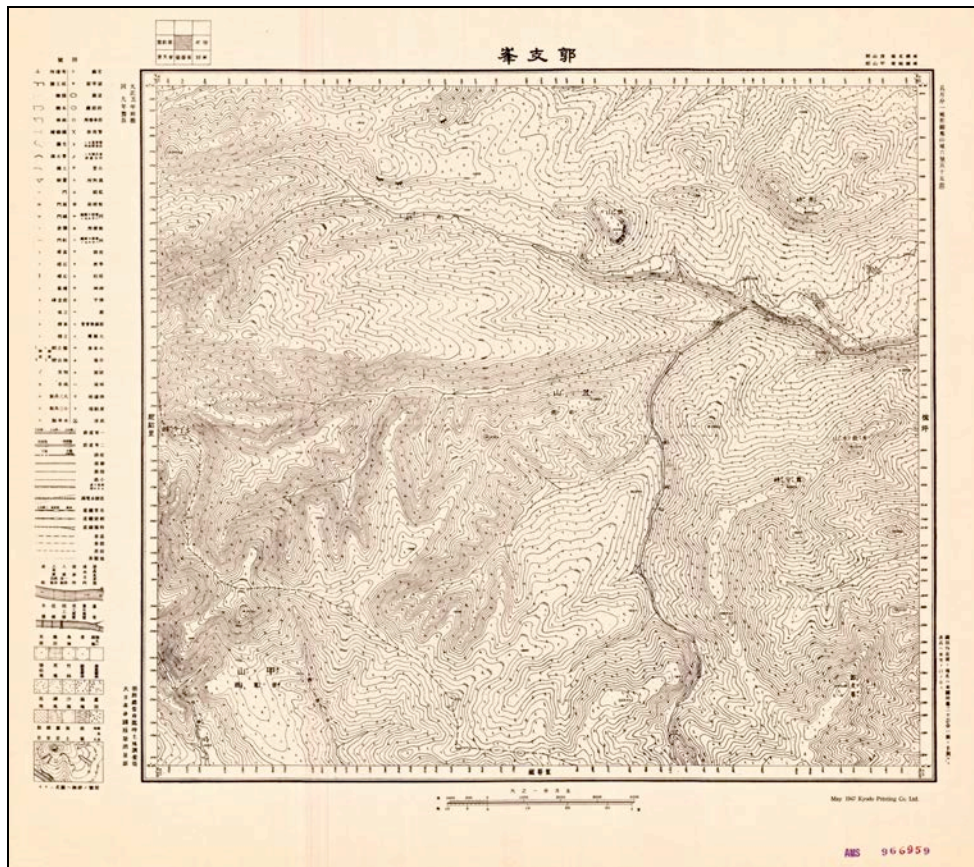
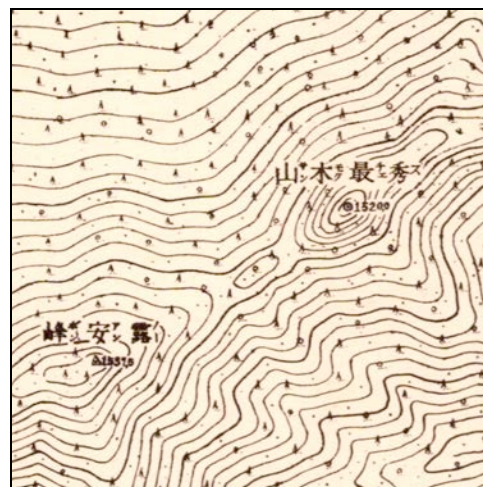
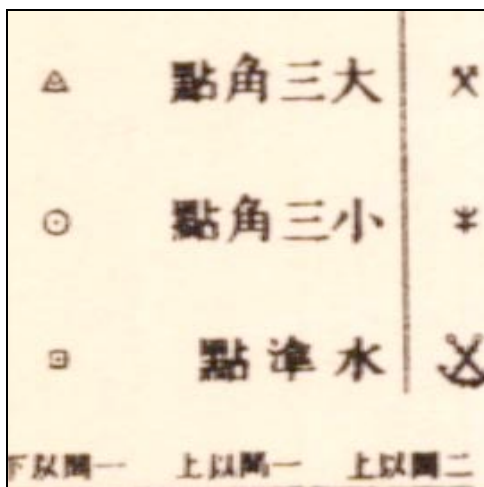

Figure 7 (left). Primary, secondary, and leveling points as they appear in the legend of figure 6. Figure 8 (right). A triangulation point as it appears on the map shown in figure 6.



The second salient feature of these maps is the complexity of their coding. As the legend reveals (see figure 9), these maps are extraordinarily rich sources, replete with information on infrastructure, physical morphology, the built environment, political borders, and other spatial data.⁶ One can only speculate as to how all of this information was gathered and processed, but it appears that the patchwork of information inscribed onto these maps was the product of multiple assessments of Korea's landscape. Although surveyors were ultimately accountable for all of this information, the collection and consolidation of this assortment of information surely depended on a host of actors, experts, and informants. Important, too, is the fact that the map legend stands as a revealing display of the ways in which Japanese colonial administrators constructed and conceived of space. If, as James Scott has suggested, the modern state sought to reconfigure space into hard, fast, and calculable categories so as to render it legible to its administrators, then the legends of the state's maps present a rough sketch of the contours of the state's vision (Scott 1999). The maps produced by the government-general in Korea are notable in this regard not only for the utility their coding holds for state-led development projects (focused as they are on soil conditions, infrastructure, and geomorphology), but also for the ways in which these maps served to naturalize the administrative architecture of the colonial government by fixing political boundaries and delineating the organs of state authority.

Figure 9. Iconography of the map legend in figure 6.

Administrative Office	Boundary	Smokestack
Consulate	School	Slaughterhouse
Provincial Office	Hospital	Riverbank Support
Government-General Office	Temple	Wading Area
Police Bureau	Fortress	Railroad
Police Box	Statue	Footbridge
Army Barracks	Memorial	Wooden Bridge
Gendarmerie Headquarters	Shrine	Orchard
Powder Magazine	Buoy	Rice Paddy
Court	Memorial Site	Reedland
Market	Stone Monument	Marshland
Prison	Christian Church	Mulberry Plot
Post Office	Mausoleum	Salt Plot
Postal Facility	Garden	Elfin Forest
Telegraph Station	Stand-Alone Tree	Cultivated Plot
Mailbox	Grove	Mudfield
Tax Station	High Tower	Bog
Primary Triangulation Point	Commercial Port Gate	Slash-and-Burn Area
Secondary Triangulation Point	Waterwheel	Denuded Area
Leveling Point	Windmill	Pine Forest

Bamboo Forest	Landslide	Mountain Road
Broadleaf Forest	Exposed Rock Outlay	Tunnel
Loam Soil	Scattered Rock Outlay	Electric Line
Eroded Soil	Town Border	Ferry Boat
Grainy Soil	Surface Border	Bank Height/Water Depth
Desiccated Soil	Provincial Border	Stream
Sedimentary Composition	Highway	Water Flow
Crag	Byway	River-Crossing Site

Conclusion

From a technical standpoint, the survey process adumbrated above not only met the cartographic standards and expectations of the international community but also surpassed them.⁷ Indeed, despite Japan's late arrival to the study of geodetic triangulation, it swiftly and firmly established itself as a key international player in the geodetic sciences. The following exchange between U.S. Secretary of Commerce William Redfield and William Bowie, then chief of geodesy in the United States, at a 1917 hearing of the House Congressional Appropriations Committee regarding America's own triangulation survey plans, throws this point into sharp relief:

Mr. Bowie: It will take about \$36,000 for the triangulation and \$140,000 for the precise leveling [of the United States]. I should hope that we may be able to get this work done very much more quickly than that, and this is what we feel is absolutely necessary. Now, I can show you by way of comparison some maps of Europe and of India.

Secretary Redfield: This map shows Japan?

Bowie: Yes; that is Japan, which is on the same scale as the United States.

Redfield: Is Japan more advanced than we are in that regard?

Bowie: Yes, sir; you can see that the areas in which they have no precise leveling are very much smaller than ours; in fact, we have some areas quite as large as Japan without a single precise level bench mark in it.

Redfield: Are we equal to other nations in this work or behind them?

Bowie: In accuracy we are the equal of the other nations.... As to the amount of work done we are very far behind.... Japan started its geodetic work later than we did, but they saw the economic advantage of it and pushed it to a rapid completion; that is, the framework. I would call it the backbone. It corresponds to the steelwork of a skyscraper and you have to put up your steelwork first in building a skyscraper. (United States Congress House Committee on Appropriations 1917, 1100–1101)

Bowie's words not only attest to the keen interest the international community had in Japan's cartographic endeavors but also to the vital importance these surveys held for statist development. A "backbone" for economic planning, these surveys provided the blueprints with which the state would draw up its modernizing agenda. It is unsurprising that the government-general in Korea hastened to produce a set of such maps. In addition to clarifying capital assets, landholding patterns, and administrative jurisdictions, these surveys facilitated a wide range of state-led planning projects that were central to Japan's vision for reforms and progress. Although planners and administrators also employed their own sets of specialized maps, the coherent and comprehensive spatial system provided by the triangulation survey doubtless served to expedite the planning and implementation of many such projects. In the years following the survey, state planners, bureaucrats, military officials, and police repeatedly turned their gaze to the maps and registers produced by the survey as they confronted the challenges of day-to-day governance and state-driven enterprise. In this way, the map, like the host of other ethnographic surveys conducted by the government-general (Henry 2006), informed a wide range of decisions about the application of resources, governance, and the exercise of state power.

One of the most striking features of the Japanese triangulation survey in Korea—and surely one of the most salient features for students of Japanese colonialism in general—was the way in which new surveying techniques and technologies were experimented with in the colonial context before being fully embraced in the metropole. The Bamberg surveying technique, aerial photography, photogrammetry: these and other mapmaking techniques were put to the test in the colonial laboratories of Taiwan, Korea, and Manchuria before firmly establishing themselves as mainstays of colonial cartography (Kobayashi 2011). Colonial cartography is indeed just one example of the numerous ways in which "the metropolitan dog" was "wagged by its colonial tail" (Uchida 2011, 44): agricultural practices, forestry techniques, and engineering methods also underwent significant and lasting transformations in the colonial context.

Two readily identifiable factors contributed to cartographic innovations in the Korean colonial context. The first is the perceived need by Japanese administrators for an overhaul of extant cartographic knowledge. In the eyes of the government-general, Korean cartography was, with only a few exceptions, insufficient to meet the needs of proper governance. Indeed, although the Japanese had long advised the Korean government to pursue a land survey of its own, the

limited body of cartographic knowledge produced by these efforts was passed over by the Japanese upon annexation. Instead, the Land Survey Bureau was given a free hand to draw up maps of the peninsula on its own terms, which doubtless facilitated experimentation. The second is the fact that, as one of the most pressing cartographic projects in the Japanese empire at the time, the Korean land survey was placed under the oversight of some of Japan's most capable cartographers, many of whom were tenacious in their pursuit of accuracy and innovation. As Taiwan was before it, Korea became a priority project for Japan's mapmaking institutions and a breeding ground for young, promising cartographers.

While this paper has done little in the way of explicating the close-knit network of individuals and institutions engaged in geodetic surveying, it is hard to overstate the importance these individuals played in the triangulation survey of Korea. The prevailing standards, conventions, and wisdom about surveying flowed swiftly through the institutional and interpersonal circuitry of the Land Survey Bureau, government-general, Japanese military, and many universities engaged in geodetic research. This network not only channeled ideas and information, but also was instrumental in determining the flow of human capital, the many surveyors and administrators who were dispatched across the empire where they contributed to the production of cartographic knowledge in a wide range of capacities—from fieldwork to data input to academic research and teaching. This network expanded well beyond Korea. In a sense, it expanded in tandem with the reaches of the empire itself: as Japan acquired new territories, mapmakers were dispatched to ever more distant regions of Asia, where they would not only produce map sheets but also train local surveyors and conduct their own research. By 1945, a vast web of mapmakers, mapping stations, schools, and collaborating institutions stretched across Japan's empire, then spanning the Asia-Pacific (Kobayashi 2009, 2011).

The history of the triangulation survey of Korea is also a human story—one replete with the complexities, frustrations, and setbacks that come with any task as intricate and taxing as a triangulation survey. In Korea, the remote, mountainous regions of the northeast proved resistant to easy mapping and many regions necessitated multiple surveys and revisions. These difficulties were compounded by the challenges of translation, human error, resistance, and weather—all of which conspired to tax the patience, resolve, and resources of these mapmakers. Yet the veneer of scientific precision and objectivity projected by these maps obscures the challenges and

complexities inherent to this process. It is therefore imperative that we also consider the rhetorical qualities of these maps—the ways in which these maps convey the values, assumptions, and worldviews of their creators. For no matter how thoroughgoing or precise Japanese surveyors thought their mapmaking enterprise, the surveying process was in its very essence an exercise in reduction. Far from comprehensive, objective, or neutral, these maps convey abstractions of reality, informed by the sort of “propositional logic” described here by Denis Wood (2010, 41):

Mapmakers are not cognitive agents parachuted into a pre-given world with a chain and theodolite, to measure and record what they find there. Rather they’re extraordinarily selective creators of a world—not *the* world, but *a* world—whose features they bring into being with a map.

Following Wood, many critical cartographers have challenged the notion of the scientific map as a neutral, benign, or objective representation, suggesting alternatively that we should treat it as a value-laden construction, one valuable not only for its conveyance of spatial information but also for its rhetorical and ideological strategies (Edney 1990; B. Harley 1989; Monmonier 1993). Perhaps the most striking rhetorical feature of these maps is the aesthetic finish of science: the premium placed on the precise, rigorous, and empirical representation of space. Stripped of artistry and embellishments, these maps evince nothing but cold, hard fact: a representational strategy that occludes the limitations and lacunae of these maps. The spiritual and geomantic topographies of Koreans’ everyday life are one such lacuna, but many others exist.⁸

Perhaps the greatest lacuna of all is reserved for historiography: the absence of critical analyses of Japanese colonial mapmaking as a process. As this paper has shown, Japanese colonial cartographic materials were born of an intricate process. These maps did not emerge from a vacuum; rather, they were constructed in a colonial context animated by the same aspirations, emotions, and power relations that ran latent throughout Korean society under Japanese rule. To take these maps as natural or neutral—to examine their content solely for what they tell us about space—is thus to overlook the ways in which the surveying process marked (and was marked by) social relations, power dynamics, and everyday interactions. This short paper has striven to lay the groundwork for a critical interpretation of these maps as both a product and a process, but much work remains.

David Fedman is a PhD student in history at Stanford University.

Notes

1. Present at the conference were delegates from Austria, Belgium, Chile, Denmark, France, Germany, Greece, Great Britain, Holland, Hungary, Italy, Japan, Mexico, the Netherlands, Norway, Portugal, Romania, Russia, Sweden, Switzerland, and the United States. The member nations also discussed a proposal to bring China and Brazil into the organization (*Nature* 1909, 351).
2. While the rise of the geodetic sciences in Japan lies outside the scope of this paper, suffice it to note that geodesy as a field of scientific inquiry in Japan well predates the advent of the triangulation survey. Many accounts of its rise begin with the studies of the Dutch Learning School (*rangakusha*) and its keen interest in astronomical observations. The first astronomical observatory was built by the shogunate in 1807 and a series of nationwide mapmaking projects followed, including, most notably, those by Inō Tadataka. It was not until after the Meiji Restoration in 1886, however, that the geodetic sciences became an institutionally backed, systematically studied field of scientific inquiry. The establishment in 1881 of the General Staff Headquarters Survey Bureau ushered forth the most concerted effort by the Japanese government to train experts in the geodetic sciences and to produce scientifically rigorous triangulated maps. For an overview of the development of the geodetic sciences in Japan see Kuroda, Berry, and Sugimoto (2001), Treiber (2004), and Wigen (2010).
3. To date, the most extensive treatments of this topic in English are Nam (1997) and Treiber (2004).
4. According to Edwin Gragert, the author of the most authoritative English-language work on the history of the Japanese cadastral survey in Korea, “within a village, survey officials announced that individuals claiming ownership to land in the village should report such claims within a fixed period of time, usually 20 days. Forms were distributed for this purpose, requesting the following information: full name of owner, location of each plot owned, type of land (paddy upland, residential, etc.), its registration number, its boundaries, its grade and its productivity. While each plot was being physically surveyed, these reports were compiled and compared to yang’an records” (1994, 24).
5. Interestingly, much of the hardware employed by the surveyors was imported from abroad, where the manufacturing of these complex instruments was far superior to that in Japan. The importation of French and German optics, in particular, allowed the Japanese to work with cutting-edge surveying instruments without having to produce these tools domestically. For an overview of the tools used by these surveyors and the origin of their production, see Hayashi (1936, 1938).
6. This map legend bears comparison with those produced in earlier periods by Japanese cartographers mapping the archipelago, especially those encoded onto what Kären Wigen calls the “geography of the state”: maps characterized by “a no-nonsense style, an industrial technique, an emphasis on mathematical rigor, and a standardized treatment of toponyms” (2010, 102). Such a comparison not only reveals how the cartographic conventions of Japanese maps have changed over time, but also how the categorization of space took its own particular forms in the colonial context.
7. It is noteworthy that by geodetic standards these maps are astoundingly accurate. Indeed, with but a few exceptions these maps hold up to the highest of cartographic standards: one need only

overlay one such map over a GIS-based map to see why. More recent GPS-driven mapping has in fact used the original triangulation points as control points for new GIS-based survey efforts. As Yang Chul-Soo has shown, the original set of coordinates and baselines constructed during the triangulation survey have been “updated” by Korean mapmakers for GPS observation. Interestingly, according to Yang, “80% of these triangulation points and original records were lost during the 3-year Korean War” (2005, 2).

8. A few words are in order about the ways in which Japanese colonial cartography left an imprint on Korea’s own cartographic traditions. Korean cartographies undoubtedly persisted, however quietly, into the colonial period. The deep-rooted tradition of geomantic mapmaking, in particular, carried on into the colonial period and, according to Yoon Hong-Key, sometimes served to orient Japanese surveyors in their earliest engagements on the peninsula (2006). Distinguished by their emphasis on mountains, waterways, and burial sites, Korean maps were impressive in their scope, volume, and quality. Indeed, despite a “lively curiosity about Western observation and cartographic sciences,” precolonial Korean maps, writes Gari Ledyard, “continued to develop on their own as if nothing had happened” (1995, 344). No single individual embodies this tradition more than Kim Chŏng-ho (1804–1866?), a cartographer and itinerant explorer who produced one of the most impressive sets of maps covering the entire peninsula. It is, of course, impossible to determine how, exactly, Korea’s mapmaking tradition was reshaped by the colonial state, but the question merits further consideration. Although the geomantically propitious sites of Korea might appear as geographical features on Japanese maps, these representations do little to reveal the spiritual topographies that continue to orient life for many in Korea into the present.

References

- Addas, Michael. 1990. *Machines as the Measure of Men: Science, Technology, and Ideologies of Western Dominance*. Ithaca, NY: Cornell University Press.
- Atkins, E. Taylor. 2010. *Primitive Selves: Koreana in the Japanese Colonial Gaze*. Berkeley: University of California Press.
- Bassett, Thomas J. 1994. “Cartography and Empire Building in Nineteenth-Century West Africa.” *Geographical Review* 84 (3): 316-335.
- Bayly, C.A. 2000. *Empire Information and Social Communication in India, 1780-1870*. Cambridge, UK: Cambridge University Press.
- Botsman, Daniel V. 2005. *Punishment and Power in the Making of Modern Japan*. Princeton, NJ: Princeton University Press.
- Burnett, D.G. 2000. *Masters of All they Surveyed: Exploration, Geography and a British El Dorado*. Chicago: University of Chicago Press.
- Cary, Edward Richard. 1916. *Geodetic Surveying*. New York: John Wiley and Sons.
- Chōsen. 1910. “Kankoku tochi chōsa junjo.” 29: 111.
- Dudden, Alexis. 2004. *Japan’s Colonization of Korea: Discourse and Power*. Honolulu: University of Hawaii Press.
- Edney, Matthew. 1990. *Mapping an Empire: The Geographical Construction of British India, 1765-1843*. Chicago and London: University of Chicago Press.
- Ericson, Steven. 1996. *The Sound of the Whistle: Railroads and the State in Meiji Japan*. Cambridge, MA: Harvard University Asia Center.

- Frühstück, Sabine. 2003. *Colonizing Sex: Sexology and Social Control in Modern Japan*. Berkeley: University of California Press.
- Government-General of Korea [GGK]. 1911. Annual Report of Progress and Reforms in Korea, 1910-1911. Seoul: Government-General of Chosen.
- . 1914. Annual Report of Progress and Reforms in Korea, 1912-13. Seoul: Government-General of Chosen.
- . 1915. Annual Report of Progress and Reforms in Korea, 1913-14. Seoul: Government-General of Chosen.
- . 1918. Annual Report of Progress and Reforms in Korea, 1916-17. Seoul: Government-General of Chosen.
- Gragert, Edwin. 1994. *Landownership Under Colonial Rule: Korea's Japanese Experience, 1900-1935*. Honolulu: University of Hawaii Press.
- Hagino, Toshio. 1965. *Chōsen, Manshū, Taiwan no ringyō hattatsu shiron*. Tokyo: Rin'ya Kōsaikai.
- Han'guk Yōksa Yōn'guhoe T'oji Taejang Yōn'guban p'yōn. 2010. *Taehan Cheguk ūi t'oji chedo wa kŭndae*. Seoul: Hyeon.
- Harley, Brian. 1989. "Deconstructing the map." *Cartographica* 26:1-20.
- Harley, B. and P. Laxton (Ed). 2001. *The New Nature of Maps: Essays in the History of Cartography*. Baltimore, MD: Johns Hopkins University Press.
- Hastings, Max. 1988. *The Korean War*. New York: Simon and Schuster.
- Hayashi, Ichigen, 1936. *Sokuryō*. Keijō: Maruzen kabushiki kaisha.
- . 1938. *Sokuryō tsūron*. Keijō: Publisher unknown.
- Headrick, Daniel. 1981. *The Tools of Empire: Technology and European Imperialism in the Nineteenth Century*. Oxford, UK: Oxford University Press.
- Helmert, F. R. 1909. "Meeting of the International Geodetic Association." *The Observatory* 32:375-378.
- Henry, Todd. 2006. *Keijō: Japanese and Korean Constructions of Colonial Seoul and the History of its Lived Spaces, 1910-1937*. PhD diss., University of California, Los Angeles.
- Keijō Nippō. 1910. "Tochi chōsa to tōkan." March 2.
- . 1918. "Tochi chōsa." January 5.
- Kim, Hong-sik. 1997. *Chosŏn t'oji chosa saōp ūi yōn'gu*. Seoul: Minŭmsa.
- Kobayashi, Shigeru. 2009. *Kindai nihon no chizu sakusei to Ajia taiheiyō chiiki—gaihōzu e no apurōchi*. Suita: Osaka Daigaku Shuppankai.
- . 2011. *Gaihōzu: Teikoku nihon no ajia chizu*. Tokyo: Chūō Kōron Shinsha.
- . 2012. "Japanese Mapping of Asia-Pacific Area, 1873-1945: An Overview." *Cross-Currents: East Asian History and Culture Review* 2, March. (<http://cross-currents.berkeley.edu/e-journal/issue-2>)
- Kobayashi, S. and Kunitada N. 2007. "Okinawa-ken ni okeru tochi seiri jigiyō no junbi katei." *Machikaneyama ronsō*. 41:1-24.
- Kuroda Hideo, Mary Elizabeth Berry, Sugimoto Fumiko, eds. 2001. *Chizu to ezu no seiji bunkashi*. Tokyo: University of Tokyo Press.
- Ledyard, Gari. 1995. "Cartography in Korea," In *The History of Cartography, Cartography in*

- the Traditional East and Southeast Asian Societies*, edited by J. B. Harley and David Woodward, 235-346. Chicago: University of Chicago Press.
- Maeil Sinbo. 1911. "Chosŏn samgak ch'ŭngnyang." August 15.
- . 1918. "Ch'ŭngnyang chedo." November 2.
- McCune, Shannon. 1946. "Maps of Korea." *The Far Eastern Quarterly* 5 (3):326-329.
- Mitchell, Timothy. 2002. *Rule of Experts: Egypt, Techno-politics, Modernity*. Berkeley: University of California Press.
- Miyajima, Hiroshi. 1991. *Chōsen tochi chōsa jigyōshi no kenkyū*. Tokyo: Kyūko Shoin.
- Monmonier, Mark. 1993. *Mapping it Out: Expository Cartography for the Humanities and Social Sciences*. Chicago: The University of Chicago Press.
- Mundy, Barbara. 2000. *The Mapping of New Spain: Indigenous Cartography and the Maps of Relaciones Geograficas*. Chicago: University of Chicago Press.
- Nakagiri, Masao. 2009. "Tōkyō Tenmondai shodai dancho Terao Hisashi no kakeizu o nyūtei." *Kokuritsu tenmondai tenmon jōhō sentaa, Tenmon Geppō* 102 (5): 332-342.
- Nam, Young-Woo. 1997. "Japanese Military Surveys of Korean Peninsula in the Meiji Era." In *New Directions in the Study of Meiji Japan*, edited by H. Hardacre and A. Kern, 335-342. Leiden: Brill.
- . 2006. "Kankoku ni okeru gaihōzu no igi to gakujiyutsu teki kachi." *Gaihōzu Kenkyū* Grūpu, *Gaihōzu Kenkyū Nyūzuretaa* 4:27-31.
- Nature*. 1909. "Notes." 2081 (81): 351.
- Oh, Se-Mi. 2008. *Consuming the Modern: The Everyday in Colonial Seoul, 1915-1937*. PhD diss., Columbia University.
- Pratt, Mary Louise. 1992. *Imperial Eyes: Travel Writing and Transculturation*. London: Routledge.
- Reinsch, Paul. 1911. *Public International Unions: Their Work and Organization*. Boston and London: Ginn and Company.
- Rinji tochi chōsa kyoku. 1918. *Chōsen tochi chōsa jigyō hōkokusho*. Seoul: Chōsen sōtokufu rinji tochi chōsa kyoku.
- Scott, James. 1999. *Seeing Like a State: How Certain Schemes to Improve the Human Condition Have Failed*. New Haven, CT: Yale University Press.
- Takagi, Kikusaburō. 1966. *Nihon ni okeru chizu sokuryō no hattatsu ni kan suru kenkyū*. Tokyo: Kazama Shobō.
- Thongchai, Winiachakul. 1994. *Siam Mapped: The History of a Geo-body of a Nation*, Honolulu: University of Hawaii Press.
- Treiber, John. 2004. *Mapping Manchuria: The Japanese Production of Knowledge in Manchuria-Manchukuo to 1945*. PhD diss., University of Hawaii.
- Uchida, Jun. 2011. *Brokers of Empire: Japanese Settler Colonialism in Korea, 1876-1945*. Cambridge, MA: Harvard University Asia Center.
- Uden, Martin. 2003. *Times Past in Korea: an Illustrated Collection of Encounters, Events, Customs and Daily Life Recorded by Foreign Visitors*. London: Routledge/Curzon.
- United States Congress House Committee on Appropriations. 1917. "Sundry Civil Bill, Part 2." Washington DC: Government Printing Office.
- Unno, Fukuju. 1997. "Chōsen sokuzu jigyō to chōsen minshū." *Meiji Daigaku, Sundai Historical Review, Kenkyū Nōto*, 49-72.

-
- Wada, Ichirō. 1967. *Chōsen tochi chizei seido chōsa hōkokusho*. Tokyo: Sōkō Shobō.
- Walker, Brett. 2005. *The Lost Wolves of Japan*. Seattle: University of Washington Press.
- Wigen, Kären. 2010. *A Malleable Map: Geographies of Restoration in Central Japan, 1600-1912*. Berkeley: University of California Press.
- Wood, Denis. 2010. *Re-Thinking the Power of Maps*. New York: Guildford Press.
- Yamachika, Kumiko. 2011. "Japanese Imperial Maps of the Meiji Era in the Library of Congress Collection: An Analysis of the Explanatory Notes and Legends." Unpublished paper presented at "Japanese Imperial Maps as Sources for East Asian History: A Symposium on the History and Future of the Gaihōzu," Stanford University, October 8th.
- Yang, Chul-Soo. 2005. "Updating and Re-establishment of Cadastral Control Points in Korea by Using GPS Observations," Working paper, available online.
- Yang, Daqing. 2011. *Technology of Empire: Telecommunications and Japanese Expansion in Asia, 1883-1945*. Cambridge, MA: Harvard University Asia Center.
- Yi, Ki-bong. 2011. *Chosŏn ui chido ch'ŏnjaedŭl*. Seoul: Saemunsa.
- Yi Kyōng-sik. 1986. *Chosŏn chŏn'gi t'oji chedo yŏn'gu: t'oji pun'gŭpche wa nongmin chibae*. Seoul: Ilchogak.
- Yokoyama, Yoshinori. 2001. "19 seiki nihon kinkai sokuyrō ni tsuite." In *Chizu to ezu no seiji bunkashi*, edited by Kuroda Hideo, M.E. Berry, and Fumiko Sugimoto, 269-344. Tokyo: Tokyo Daigaku Shuppankai.
- Yoon, Hong-Key, 2006. *The Culture of Feng-Shui in Korea: an Exploration of East Asian Geomancy*. Lanham, UK: Lexington Books.