

Lawrence Berkeley National Laboratory

Recent Work

Title

POLLUTANT EMISSION RATES FROM UNVENTED GAS-FIRED SPACE HEATERS: A LABORATORY STUDY

Permalink

<https://escholarship.org/uc/item/5zh185qt>

Author

Girman, J.R.

Publication Date

1983-04-01

c.2



Lawrence Berkeley Laboratory

UNIVERSITY OF CALIFORNIA

ENERGY & ENVIRONMENT DIVISION

RECEIVED
LAWRENCE
BERKELEY LABORATORY

JUN 8 1983

LIBRARY AND
DOCUMENTS SECTION

POLLUTANT EMISSION RATES FROM UNVENTED GAS-FIRED
SPACE HEATERS: A LABORATORY STUDY

J.R. Girman, J.R. Allen, M.G. Apte, V.M. Martin,
and G.W. Traynor

April 1983

TWO-WEEK LOAN COPY

*This is a Library Circulating Copy
which may be borrowed for two weeks.
For a personal retention copy, call
Tech. Info. Division, Ext. 6782.*

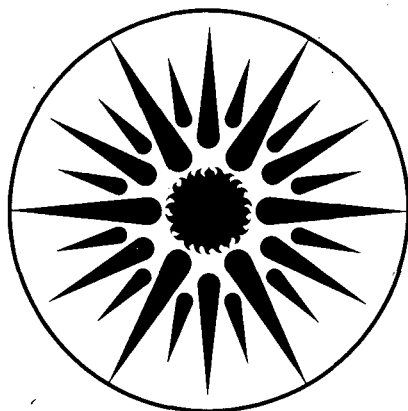

**ENERGY
AND ENVIRONMENT
DIVISION**

LBL-14502
c.2

DISCLAIMER

This document was prepared as an account of work sponsored by the United States Government. While this document is believed to contain correct information, neither the United States Government nor any agency thereof, nor the Regents of the University of California, nor any of their employees, makes any warranty, express or implied, or assumes any legal responsibility for the accuracy, completeness, or usefulness of any information, apparatus, product, or process disclosed, or represents that its use would not infringe privately owned rights. Reference herein to any specific commercial product, process, or service by its trade name, trademark, manufacturer, or otherwise, does not necessarily constitute or imply its endorsement, recommendation, or favoring by the United States Government or any agency thereof, or the Regents of the University of California. The views and opinions of authors expressed herein do not necessarily state or reflect those of the United States Government or any agency thereof or the Regents of the University of California.

Pollutant Emission Rates from Unvented Gas-fired Space Heaters:
A Laboratory Study

J.R. Girman, J.R. Allen, M.G. Apte, V.M. Martin, and G.W. Traynor

Building Ventilation and Indoor Air Quality Program
Lawrence Berkeley Laboratory
University of California
Berkeley, California 94720

April 1983

This work was supported by the Director, Office of Energy Research, Office of Health and Environmental Research, Human Health and Assessments Division of the U.S. Department of Energy under Contract No. DE-AC03-76SF00098, and by the Directorate for Health Sciences of the U.S. Consumer Products Safety Commission under Contract No. CPSC-IAG-81-1375.

ABSTRACT

Operation of an unvented combustion appliance indoors can elevate pollutant levels. We have determined the emission rates and source strengths of a variety of pollutants emitted from eight unvented gas-fired space heaters operated with well adjusted air shutters at partial and full input in a 27-m³ chamber under a range of ventilation conditions. Emission rates were also determined for some heaters with poorly adjusted air shutters. In addition to monitoring carbon monoxide, carbon dioxide, nitric oxide, nitrogen dioxide, formaldehyde, and respirable suspended particles, we also determined oxygen consumption rates. Results indicate that the emissions of nitrogen dioxide and carbon dioxide from all heaters were high enough to be of concern, both in single-room environments and, based upon calculation, in residential-sized buildings. Depending upon the particular heater and its specific air shutter adjustment, carbon monoxide and, to a lesser extent, formaldehyde emissions can be high enough to cause concern. The emission rates from this study can be used along with information about building characteristics to calculate pollutant levels in a wide variety of indoor environments.

Keywords: air shutter, combustion, carbon dioxide, carbon monoxide, emission rates, formaldehyde, indoor air quality, nitric oxide, nitrogen dioxide, nitrogen oxides, pollutants, respirable suspended particles, space heater, tuning, unvented.

INTRODUCTION

To deal with the risk of acute carbon monoxide exposure from unvented gas-fired space heaters (UVGSH), the U.S. Consumer Products Safety Commission (CPSC) has promulgated a standard requiring an oxygen-depletion sensing device (ODS) on all UVGSHs. Out of increasing concern about possible health effects from chronic exposure to CO and other pollutants produced by the heaters, CPSC contracted with the Building Ventilation and Indoor Air Quality (BVIAQ) group of Lawrence Berkeley Laboratory in July, 1981 to provide a technical study of pollutant emissions from UVGSHs that would ultimately provide a basis for predicting pollutant exposure from these appliances.

In this report, we cover the results obtained from the first phase of our two-phase investigation of UVGSHs -- laboratory determination of oxygen (O_2) consumption rates and emission rates of five selected gas-phase pollutants: carbon monoxide (CO); carbon dioxide (CO_2); nitric oxide (NO); nitrogen dioxide (NO_2); and formaldehyde (HCHO). Submicron particulate levels, temperature, and humidity were also monitored. A report on the second phase, a controlled field study of pollutant concentrations produced by these heaters in a research house, will follow.

EXPERIMENTAL

To cover the range of unvented gas-fired space heaters available to U.S. consumers, CPSC selected eight heaters from each of the three U.S. manufacturers for tests. Because they were unavailable at the time of testing, none of the heaters tested were equipped with an ODS. As rated by the manufacturers, fuel inputs for the heaters selected ranged from 12,700 kJ/h to 42,200 kJ/h (12,000 Btu/h to 40,000 Btu/h). Physically the heaters ranged in size (L x W x D) from 44.5 cm x 31.8 cm x 24.8 cm (17 1/2 in x 12 1/2 in x 9 3/4 in) to 66.7 cm x 63.8 cm x 38.7 cm (26 1/4 in x 25 1/8 in x 15 1/4 in). All heaters incorporated removable ceramic inserts positioned over the burner to serve as radiant elements. The radiant elements on all heaters were at least two cm. from the

burner assemblies.

Extensive emission rate testing was conducted on these eight heaters in four series of tests. The first series of tests was conducted on well-tuned heaters operated at full input, all eight under low-ventilation conditions and three under medium- and high-ventilation conditions. A second series of tests was conducted with the same heaters and ventilation conditions but at partial input. A third series was run on two of the heaters under two conditions of maltuning, with the air shutters fully open and fully closed. In a final series, three heaters were tested under equilibrium (steady-state) conditions at several O_2 levels (18%-20% O_2) and at several different air-shutter settings.

All emission rate tests were conducted with the heaters operating in the BVIAQ environmental chamber, and gas-phase pollutant concentrations (with the exception of formaldehyde) were monitored by the Mobile Atmospheric Research Laboratory (MARL) (see Figure 1).

Environmental Chamber

The BVIAQ environmental chamber is a 27-m^3 (950-ft^3) structure housed within a larger building that serves to buffer it from wind and temperature fluctuations, thus providing some measure of control over its external environment. The ventilation rate of the chamber can be varied mechanically from 0.25 to 7.0 air changes per hour. Forced convective mixing of the air in the chamber can be controlled by one to six miniature variable-speed fans appropriately placed throughout the chamber.

When testing combustion appliances that produce large amounts of heat, the temperature inside the chamber must be kept within reasonable bounds. The conventional method of cooling the chamber air (by an air conditioner) was not an option in this study because it could have a severe "scrubbing" effect on water-soluble pollutants such as CO_2 , NO_2 , and HCHO, and cause plateout of particles. Consequently we relied on thermal absorption of heat into the floor (which has a large thermal

mass), transfer of heat through the walls of the chamber (which has minimal insulation), and absorption of the heat from the UVGSHs into a "cold wall". (A water-cooled "cold wall", composed of two flat black, solar panels, was installed to remove radiant heat from the UVGSHs.) An air conditioner was also installed outside the chamber to cool the building housing the chamber.

To allow a fast startup and to avoid any contribution to pollutant concentrations from the pilot light before the main burner ignites, a nichrome wire coil wrapped around glass tubing was placed on the thermocouple of each heater. When heated, this coil prevented operation of the safety shutoff valve. In addition, to preclude emissions from a combustion source other than the UVGSHs (such as a match), a piezoelectric sparker was used to ignite the heaters.

Fuel-consumption measurements were made using a standard calibrated gas meter. Fuel-line pressure was controlled by an in-line pressure regulator which was set within manufacturer-specified limits for each heater.

Instrumentation

As indicated in Figure 1, most of the monitoring instrumentation is located in the MARL. For formaldehyde and particles, however, samplers were positioned immediately outside the chamber, in the case of HCHO, for the ease of servicing and, in the case of particles, to avoid sampling-line plateout. Particle concentrations were analyzed in a size range of 0.0056 to 0.56 μm in diameter using an electric mobility analyzer and assuming a particle density of 2.0 g/cm^3 . Temperature and humidity probes were positioned inside and outside the chamber. (A complete list of instrumentation used and the accuracy limits published by the manufacturer for each instrument is presented in Table 1.)

The MARL can continuously draw samples through Teflon tubing from four locations (three inside and one outside the chamber) and use a timing system to automatically switch from one site to the next at a preset intervals. Teflon prefilters fitted at the inlets of the sampling lines are changed daily to protect the instruments from particulate matter. Although the MARL can only monitor gases from a single location at a given time, all lines draw continuously so that the switch-over can be made without delay. Lines that are not being monitored are vented to the outside via an exhaust pump. A Teflon-lined pump supplies the sample from the site being monitored to the glass mixing manifold and maintains manifold pressure just above atmospheric. The gas analyzers draw the sample from the manifold by means of individual pumps. (Only non-reactive materials are used upstream of the gas analyzers to assure minimum degradation of the sample.) During a typical test the total sample flow was 9 L/min or less.

The MARL calibration system was designed for rigorous calibration of the gas analyzers (CO , CO_2 , NO , NO_2 , O_2). At a minimum, calibration was performed prior to testing each day. Certified gas mixtures are diluted with "ultrapure" air using a mass-flow controlled mixing system to produce a large range of concentrations used for calibration. To check for problems such as a bad pump diaphragm or leaky lines, a gas of known concentration is injected into the sampling lines.

Two data-acquisition systems connected to a central patchboard are used during sampling. One, a microprocessor-based system fabricated at LBL specifically for the MARL, logs primary data on magnetic tape at one-minute intervals. The second system provides back-up capability by printing data on paper tape. A chart recorder connected to the patchboard is used for real-time graphic display of an experiment in progress. Particulate data are printed on an LBL-built single-channel datalogger. At the end of an experiment, data from the magnetic tape are read into a mainframe computer for subsequent analysis. (Because HCHO analysis requires batch-system processing, these data are reduced by hand.)

Model

The model used to determine emission rates was developed by Traynor et al.¹ Much of this treatment is reproduced here to facilitate understanding the results reported. This model employs a mass-balance treatment of the basic physical/chemical processes that describe the behavior of pollutants in an enclosed chamber. Increases in indoor air pollutant levels occur as a result of the flow of outdoor pollutants into the interior environment (less the fraction that is removed by the building shell) and the rate at which pollutants are generated indoors. Decreases in indoor pollutant levels occur as a result of the flow of indoor air out of the interior environment and the rate at which indoor pollutants are removed via various chemical and physical removal processes that occur completely within the interior environment (e.g., wall adsorption). The mathematical expression for the change in indoor pollutant mass is:

$$dQ = Pq C_o dt + S dt - qC dt - \kappa Q dt \quad (1)$$

where:

Q = mass of interior pollutant (μg);

P = fraction of outdoor pollutants that penetrates the shell (unitless), (1.0 = 100% penetration);

q = volumetric ventilation/infiltration flow rate (m^3/h);

C_o = outdoor pollutant concentration ($\mu\text{g}/\text{m}^3$);

C = Q/V = average indoor pollutant concentration ($\mu\text{g}/\text{m}^3$);

S = generation rate of indoor pollutants, also called source strength ($\mu\text{g}/\text{h}$);

k = net rate of removal by processes other than air flow (h^{-1});

V = chamber volume (m^3);

a = q/V = air exchange rate in air changes per hour (ach) (h^{-1}); and

t = time (h).

For gases, C and C_o are in units of parts-per-million (ppm) and S is in units of cm^3/h . Dividing Equation 1 by V , we have:

$$dC = Pa C_o dt + \frac{S}{V} dt - (a+k) C dt \quad (2)$$

Solving for $C(t)$ we have:

$$C(t) = \frac{PaC_o + S/V}{(a+k)} \left[1 - e^{-(a+k)t} \right] + C(0)e^{-(a+k)t} \quad (3)$$

Equation 3 describes the average spatial concentration of a pollutant in an enclosed space of a given volume.

Many assumptions are implicit in this description. One is that the pollutant concentration of the air that flows out of the chamber is the same as the average indoor concentration. (The use of mixing fans helps ensure that this assumption is correct.) Another assumption is that S , C_o , P , a , and k are all constant over the time period employed. In our experiments, the pollutant source strength ranges from a non-zero value (when the appliance is turned on) to zero (when the appliance is turned off). Two separate equations linked by boundary conditions are needed to describe the concentration of a pollutant over the entire time period. Rearranging Equation 3 to isolate the non-zero source strength (expressed as S/V for convenience), and letting T equal the duration the appliance is operated, gives us:

$$\frac{S}{V} = (a + k) \frac{\left[C(T) - C(0)e^{-(a+k)T} \right]}{\left[1 - e^{-(a+k)T} \right]} - PaC_o \quad (4)$$

Finally, by multiplying Equation 3 by V and dividing by the fuel consumption rate, R (kJ/h), we can obtain the emission rate, E ($\mu\text{g}/\text{kJ}$ for particles and cm^3/kJ for gases):

$$E = \frac{S}{R} = \frac{V}{R}(a+k) \frac{[C(T) - C(O)e^{-(a+k)T}]}{[1 - e^{-(a+k)T}]} - \frac{VPaC_o}{R} \quad (4a)$$

For gases, E in cm³/kJ can be converted to μg/kJ by using the ideal gas law and the time-weighted average temperature and pressure in the chamber. Note that Equations 4 and 4a rely on the final average indoor pollutant concentration, C(T), rather than on the temporal concentration profile, suggesting that the use of a mixing fan is not necessarily required if all of the mentioned and implicit assumptions are met and C(T) can be reliably determined.

Once appropriate experimental conditions are established, Equation 4 can be simplified to solve for the following parameters:

Air Exchange Rate, a

After the combustion appliance is turned off (i.e., when S = 0), the air exchange rate, a, is determined for each experiment by using a non-reactive tracer gas (i.e., one with k = 0 and P = 1) such as CO or CO₂. Equation 4 can then be rewritten with t denoting the length of time the appliance is off, i.e.:

$$C(T+t) - C_o = [C(T) - C_o]e^{-at} \quad (5)$$

By taking the natural logarithm of both sides, a is easily determined through a multipoint linear regression.

Indoor Pollutant Reactivity, k

The indoor pollutant reactivity, k, is determined in a manner similar to that used to determine a. The combustion appliance is operated long enough to ensure that

$$C(T) \gg C_o \quad (6a)$$

and

$$C(T) \gg C(0) \quad (6b)$$

With $S = 0$, Equation 4 reduces to:

$$C(T+t) = C(T)e^{-(a+k)t} \quad (7)$$

By taking the natural logarithm of both sides, $(a + k)$ can be determined, again through a multipoint linear regression. Since a is known from the previous calculation, k can now be determined.

Peak Indoor Concentration, $C(T)$

The peak indoor concentration was determined from a multipoint fit of Equation 5 for CO , CO_2 and O_2 and of Equation 7 for NO , NO_2 , NO_x and submicron particles.

Steady-state Concentration, $C(\infty)$

For each pollutant, the steady-state concentration, $C(\infty)$, is reached when the flow of pollutants entering the chamber equals the flow of pollutants out of the chamber. By letting t approach infinity, Equation 4 reduces to:

$$C(\infty) = \frac{P_a C_o + S/V}{a + k} \quad (8)$$

For a nonreactive gas with a penetration factor of 1, such as CO , CO_2 , and O_2 , Equation 8 can be further reduced to:

$$C(\infty) = C_o + \frac{S}{aV} \quad (9)$$

Note that for a chamber with constant background concentration and source strength, the steady-state concentration is determined only by the ventilation rate.

Penetration Factor, P

The penetration factor, P, is determined when $S = 0$ and an equilibrium indoor/outdoor concentration is established. By inserting $S = 0$ and letting t approach infinity, Equation 4 reduces to:

$$C(\infty) = \frac{PaC_o}{(a+k)} \quad (10)$$

Since $C(\infty)/C_o$ can be measured and both a and k are known, P can now be calculated by rearranging Equation (8):

$$P = \frac{C(\infty)(a+k)}{C_o a} \quad (11)$$

Special procedures were used to calculate $C(T)$ and $(a + k)$ for HCHO. One-hour samples were collected after the heater was turned off. By integrating Equation 7 from t_1 to t_2 we obtain:

$$\bar{C}(T + t_1, T + t_2) = \bar{C}_1 = \frac{C(T)}{(a + k)(t_2 - t_1)} [e^{-(a + k)t_1} - e^{-(a + k)t_2}] \quad (12)$$

Based on the concentrations measured in two successive samples, \bar{C}_1 and \bar{C}_2 , sampled for equal time intervals, it can be shown that

$$(a + k) = \frac{\ln \bar{C}_1 - \ln \bar{C}_2}{(t_2 - t_1)} \quad (13)$$

A value for k was determined by inserting the air exchange rate, a , obtained from Equation 5 into Equation 13. $C(T)$ was determined from Equation 12.

Protocol - Dynamic Tests

The experimental protocol for dynamic tests of emission rates was based on the emission rate model parameters listed in Equation 4a. The volume (V) of the chamber was determined by measurement to be 27 m³. The fuel consumption rate (R, kJ/h) was measured using the gas meter and the combustion time (T). The heat of combustion of the natural gas was 31.4 kJ/L (1050 Btu/ft³), assumed constant during the laboratory testing. (The local gas utility confirms that the heat of combustion of the supplied natural gas is very constant and, at worst, varies by only a few percent.) Prior to testing emission rates, all heaters were tuned by adjusting the air shutter for a minimum output of carbon monoxide (as measured by a portable analyzer) and by visually observing the flame characteristics. For the partial input tests, fuel consumption rates were set by moving the regulator valve on the heaters to an intermediate setting between the "pilot" and "on" settings and adjusting the valve until the flame was approximately one half its normal height. After calibrating the instruments, the data-acquisition systems were started and pollutant monitoring was initiated. The particulate analyzer was set to take measurements at ten-minute intervals.

Figure 2 presents a typical pollutant profile for the UVGSH emission rate tests showing the five distinct time periods sampled. Outdoor concentrations, C_o, for all pollutants except HCHO were measured for fifteen minutes (Period 1) prior to the test. The initial indoor concentration, C(0), was then measured for fifteen minutes (Period 2). With the mixing fans on and the ventilation rate set for the particular test, the heater was ignited and allowed to consume 5 ft³ (5540 kJ) of natural gas (Period 3). After the heater was shut off, the decay of pollutant levels in the chamber was monitored for one hour (Period 4). Data from this decay period were used to calculate the air exchange rate, a, the reactivity constant, k, if appropriate, and the peak concentration, C(T), for each pollutant. Following the decay period, pollutant levels outside the chamber were measured for fifteen minutes (Period 5). At the completion of the test, the data on magnetic tape was transferred to

the computer.

As noted earlier, HCHO was measured differently from the other pollutants. Because HCHO can load up in sampling lines, the HCHO sampling lines were periodically purged with nitrogen. C(O), for HCHO, was measured periodically and generally agreed with the outside concentrations taken during the tests. A one-hour average measurement of HCHO concentration in the chamber was made during the decay portion of the test and simultaneously C_o , for HCHO, was measured outside the chamber.

Burning a constant amount of fuel simulates consumer use since a given space with known thermal properties requires a certain amount of heat to reach a prescribed temperature. A consumer will generally operate a heater until that amount of heat is produced rather than operating a heater for a fixed period of time or operating a heater to steady state. (Operation to steady state will produce too much heat under most conditions of use if the heater is appropriately sized.) Burning a constant amount of fuel in the same space, i.e., the chamber, has the added advantage of allowing comparisons of the pollutant concentrations produced by different heaters while delivering the same end product -- the same amount of heat. The amount of natural gas used in each test was chosen by balancing conflicting constraints: to obtain good data from which to determine emission rates, sufficient natural gas must be combusted to produce pollutant concentrations well above background concentrations; yet the chamber temperature should be maintained within reasonable bounds.

The experimental protocol used for the dynamic tests in this report differs from the method used by some other researchers such as Himmel and Dewerth.² They collected the appliance plume in a hood and measured the ratio of the pollutant of interest to the CO_2 concentration in the hood. Because the pollutant emission rate is then calculated by using the theoretical CO_2 emission rate of the natural gas, this method is dependent upon the composition of the natural gas. The method employed in this report actually measures the CO_2 emission rate for every test.

Therefore, the comparison of the measured CO_2 emission rate and the theoretical CO_2 emission rate provides a check on the validity of our method. This comparison is discussed in a subsequent section of this report, "Full Input Tests on Well-Tuned Heaters."

A further advantage of our test method is that combustion appliances are tested under more realistic conditions than those occurring when measuring pollutants in a hood. The hood itself may interfere with the flame characteristics of the appliance and thereby affect emission rates. The hood also removes combustion products from the space surrounding the appliance rather than allowing some fraction of the pollutants to be entrained into the combustion air as typically occurs during appliance use.

Protocol - Steady-state Tests

For steady-state tests, the pollutants were monitored while running the heater in the chamber at a low ventilation rate until the desired O_2 level was reached. The ventilation rate was then adjusted to maintain an equilibrium condition for O_2 at that level. In general, monitoring was continued until all pollutants being measured reached equilibrium.

Mixing Chamber Air

Prior to full-scale testing of the UVGSHs, we ran several tests to determine the mixing characteristics of the air in the environmental chamber and to identify the adjustments necessary to assure that the assumptions of the model were met. Low capacity fans, eight-cm in diameter, were used to improve the mixing. The fans were capable of producing no more than 17 L/s of air flow per fan. The fans were positioned to minimize the amount of time required for mixing yet still keep turbulence as low as possible to minimize particulate plateout. The minimum distance between the closest fan and an operating heater was 1.2 m. Each fan's axis was perpendicular to a line from the heater to the fan to prevent air from being blown directly at a heater.

Figure 3 shows a pollutant profile for Mixing Test 1. To assure efficient mixing throughout the chamber, four fans were mounted, one in the center of each wall, producing four opposing air-flow cells rather than a single air-flow cell centered at the middle of the chamber. Horizontal and vertical mixing were then checked by the MARL which sampled sequentially from the center of the chamber at breathing level, a high corner, and a low diagonally opposite corner. The air outside the chamber was sampled before and after the test. The mixing fans were set at slow speed. The abrupt changes in concentrations of gases that appear on the decay portion of the plot in Figure 3 simply reflect the switch from one sampling point to the next and indicate that the chamber air was not well mixed even an hour after the heater was shut off. In subsequent tests, mixing was improved considerably with the addition of two fans placed in "dead" air spaces around the cold wall and increasing the speed of the fans (see Figures 4 and 5). After well-mixed air was established, only one location was sampled.

RESULTS AND DISCUSSION

The concentration profiles for each dynamic test of all gaseous pollutants except HCHO are contained in the Appendix, together with explanatory notes on the tests. Both peak and average HCHO and particulate concentrations minus background concentrations during the decay region of the test are depicted as histograms rather than real-time concentration profiles. The peak HCHO concentration is not a measured concentration but a calculated concentration derived by the model. The average concentration, both for HCHO and particles, was averaged over the one-hour decay period.

Since all tests involved combusting the same amount of natural gas (with the exception of Tests 1 and 13) this Appendix allows quick comparisons of pollutant concentrations produced by different heaters under uniform conditions and by any given heater under different test conditions. In this Appendix and throughout the report, UVGSHs are identified by a number and letter designation, e.g., 40B, where the number

indicates the heater rating in thousands of Btu's per hour and the letter designates the manufacturer. (There are three U.S. manufacturers of UVGSHs coded in this report as A, B, and C.)

As illustrated in Figures 6 through 12, the air in the chamber was adequately mixed and the source strengths derived from Traynor's model can be used to accurately recreate the temporal concentration profiles for the pollutants. These figures, which compare the pollutant concentration profiles observed in a single test with those calculated from the model, show good agreement between measured and modeled values in all cases. The agreement in concentrations is best when sufficient time has elapsed to allow pollutants to mix uniformly throughout the chamber as is evident during the decay period. (For the concentrations to agree during the decay period the correct amount of pollutant must also necessarily have been injected, i.e., the emission rate must be correct, as well as using the correct air change rate, chamber size and, when appropriate, reactive decay constant.)

As tests were completed all data were reviewed by checking the ratios of pollutant concentrations and the correlation coefficient of the linearized decay for each pollutant except HCHO and submicron particles. If data sets had missing data blocks or instrumental transient signals caused by switching ranges, these were dealt with on an individual basis. In addition, replicate tests were run periodically to assess the reproducibility of test results. Prior to examining test results, it was important to assess the reproducibility of the emission rates determined in order to provide a basis for evaluating whether variations in emission rates are due to test methods or factors affecting heater operation, e.g., partial vs. full input, tuning, etc.

Reproducibility of Tests

Table 2 presents the pollutant emission rates determined from replicate tests. Replicate tests were those tests for a given heater where all test conditions, i.e., air shutter setting, fuel input rate, and ventilation rate, were either unchanged or reproduced as closely as possible. The relative standard deviations were calculated for each pollutant from the seven sets of experiments listed in Table 2. The means of the relative standard deviation of the emission and consumption rates are: 35% for CO; 3.0% for CO₂; 2.6% for O₂; 14% for NO; 15% for NO₂; 7.7% for N (of NO_x); 25% for HCHO; 53% for submicron particles; and 1.7% for the fuel consumption rate. (Because many emission rates for particles were below the limit of detection, only three data sets could be used in the precision estimate for particles; only six data sets could be used to calculate the fuel consumption rate because the final data set for heater 40C was a partial input test and partial input cannot be set reproducibly.) The range of the relative standard deviations are: 5.3 to 80% for CO; 0.3 to 5.0% for CO₂; 1.0 to 5.3% for O₂; 2.2 to 35% for NO; 6.2 to 27% for NO₂; 2.0 to 16% for N (of NO_x); 17 to 39% for HCHO; and 6.6 to 83% for submicron particles.

Based on the low variation of the CO₂ and O₂ replicate measurements, the precision of the overall emission rate determination technique used in this report appears to be excellent. It appears that varying emissions from the heaters themselves account for the relatively large variations observed in the CO, NO, NO₂, N (of NO_x), HCHO, and submicron particulate emission rate measurements since the observed variation is greater than the precision of their instruments and greater than the coefficients of variation for the CO₂ and O₂ emission rates. Nonetheless, it is worth noting that a high CO-emitter remains a high CO-emitter and a low CO-emitter (such as the 40C) remains a low CO-emitter in all tests with the same tuning and input. If the variation in CO emission rates were due to a failure of the model or of the assumptions implicit in the model (e.g., air in the chamber was inadequately mixed), then we would expect similar variations to occur in other pollutant

emission rates -- and they were not observed. The variation could involve the CO analyzer; however, the manufacturer reports a precision of ± 0.5 ppm for the range typically used, and we have demonstrated its linearity. It is likely that the variability in CO emission rates is inherent in these particular appliances.

Since presumably the burner assemblies are designed and engineered for uniform flow of the combustion gases through the burner ports or slots, it is expected that CO₂ and NO₂ are both produced with a relatively high degree of spatial uniformity across the whole burner assembly. (O₂ is also consumed with equivalent uniformity.) On the other hand, visual indications of incomplete combustion, such as flame lifting, flame fluttering, and yellow flame tips are usually evident only in certain regions of the burner especially when a heater is only slightly mistuned. We suspect that these regions may produce the majority of incomplete combustion products such as CO. Even with the highest CO-emitting, well-tuned heater, our tests indicate that only about 0.5% of the methane from the natural gas reacts to form CO and other products of incomplete combustion (e.g., HCHO and particles), based upon a mass balance comparing the CO₂ emitted with the HCHO, CO, and particles emitted. In other words, minor changes in combustion characteristics could significantly change the emission rate of CO. It is speculative but may serve as a basis for further investigation to suggest that small randomly occurring variations which can occur when the heater is ignited (e.g., due to the speed with which the heater valve is rotated from "pilot" to "on", to a draft impinging on the burner as it is ignited, or to slight changes in the gas pressure as it exits the burner jet) could significantly change emission rates of CO. If the heater's air shutter is adjusted such that a section of the flame is unstable with respect to production of CO, then when the heater is ignited these transients may be the final factor sufficient to determine whether or not the flame will produce large amounts of CO. Alternatively, some heaters may produce varying amounts of CO only shortly after ignition, before steady-state flame characteristics are established. This will be discussed further in the section on steady-state tests.

To further check the reliability of our results, we ran two tests on the same heater (20C) using the same input and chamber ventilation rate but in the first test combusted 5 ft³ of natural gas in 15 minutes (standard procedure) and in the second test combusted 10 ft³ in 30 minutes. Pollutant emission rates from these two tests, presented in Table 3, provide information as to whether the relatively short duration of the dynamic tests created any change in the emission rates observed. CO₂ emission rates and O₂ consumption rates for both tests fall within the range of rates observed in other tests, although both rates from the test combusting 10 ft³ are at the low end of the range. The variation observed in emission rates for the remaining pollutants -- CO, NO, NO₂, HCHO, and particles -- is reasonably consistent with the precision of the instrumentation used and the variation observed from replicate tests (see Table 2).

Full Input Tests on Well-tuned Heaters

Table 4 presents the test results for well-tuned heaters operating at full input at a low ventilation rate. "Well tuned" or "good tuning," except when otherwise indicated, denotes the intention of the test rather than an assessment of the results. That is, we attempted to optimize the tuning of a heater by adjusting the air shutter (see Protocol-Dynamic Tests); however, after the test was completed, it was sometimes evident that the heater was not optimally tuned. Except in the case of the 30A heater to be discussed in greater detail later, no re-adjustments were made since the state of tuning would not be known to a consumer and, consequently, would not be readjusted. As expected, the CO₂ emission rates (average of individual tests incorporated in Table 4 is 51,100 µg/kJ) and the O₂ consumption rates (average of individual tests incorporated in Table 4 is 70,900 µg/kJ) were relatively constant for all UVGSHs. The relative standard deviation of the measurements for both CO₂ and O₂ was 3%. Based on a spot check of the composition of the natural gas used (Pacific Gas and Electric, San Francisco, CA) we calculated a theoretical emission rate of 51,000 µg/kJ for CO₂ and a theoretical consumption rate of 73,200 µg/kJ for O₂, both values consistent

with those measured. However, this agreement should be viewed only as an indicator of accuracy, since the composition of natural gas varies periodically by a few percent and was not routinely checked.

The NO and NO₂ emission rates of these eight heaters averaged 17.3 µg/kJ and 14.1 µg/kJ respectively. The average emission rate for nitrogen oxides (NO_x = NO + NO₂) was higher than that associated with a gas-fired range,¹ the most commonly used unvented combustion appliance and an appliance often associated with elevated indoor levels of nitrogen oxides.³ Although the NO_x emission rates were fairly consistent among heaters, averaging 12.4 µg/kJ of N (in NO_x) for all eight well-tuned heaters in these tests run at low ventilation rates, the individual heater rates for NO and NO₂ showed more variation. Reasons for this variation will be discussed in the section dealing with results of tuning tests.

As noted, the CO emission rates (Table 4) were much more variable than those of other pollutants. Five heaters had CO emission rates of less than 30 µg/kJ and the other three heaters had much higher rates, up to 165 µg/kJ. Other researchers of natural gas combustion appliances have observed that the CO emission rates across appliances appear to be log-normally distributed.² Our results are consistent with this observation. The geometric mean of the CO emission rate is 34 µg/kJ.

HCHO emission rates presented in Table 4 were also assumed to follow a log-normal distribution since, like CO, HCHO is a product of incomplete combustion. The geometric mean emission rate was 0.81 µg/kJ. Heater 12A had the highest HCHO emission rate -- 4.2 µg/kJ, based upon three tests. This heater was also the only heater to operate below its rated input.

Heater 12A also had the highest particulate emission rate, 0.32 µg/kJ, in a size range of 0.0056 to 0.56 µm in diameter. The particulate emission rates from all UVGSHs followed a log-normal distribution with a geometric mean of 0.038 µg/kJ.

Variable Ventilation Tests on Well-tuned Heaters

Three UVGSHs the 30A, 16B, and 40C, were subjected to more extensive testing, i.e., with ventilation rates varying from as low as 0.2 ach to as high as 5.1 ach and operating at both full and partial inputs. Tables 5, 6, 7, 8, and 9 contain results from these tests. Table 10 presents selected data extracted from these tables for CO and NO₂ from heaters with greatly different CO emission rates. As noted previously, despite some variation in the measured CO emission rates, in general, a low CO-emitter remains low, a moderate CO-emitter remains moderate, and a high CO-emitter remains high. While there is less variation, this pattern obviously holds true for the NO₂ emission rates as well. As expected in tests where the O₂ level remained above 20%, the ventilation rate of the chamber had no direct systematic effect upon the emission rates observed; however because the correlation coefficients of the linearized pollutant decays are generally better when the ventilation rate is low, it is believed that emission rates are more accurately measured under low ventilation conditions. This certainly appears to be true for CO₂ and O₂ rates and is most probably true for others as well. With the high ventilation rates obtained through use of mechanical ventilation, it is possible for pollutants from the UVGSH to reach the ducts of the exhaust fan before sufficiently mixing with the air in the chamber, thus violating the model's assumption of well-mixed air.

Partial Input Tests on Well-tuned Heaters

As noted earlier, our tests were conducted on UVGSHs operating at full and partial input. Although all three manufacturers contacted insisted that these heaters were not designed to be used at partial input, we found that all heaters tested were capable of being operated at partial input without difficulty or deterioration in performance. The range of input adjustment, while not large, allows the user to obtain a steady-state temperature obviating the need to turn the heater off and on and thereby producing large variations in temperature. Although deemed by the manufacturers to be a misuse of the product, operating at

partial input is perhaps not uncommon among users.

Table 11 compares pollutant emission rates obtained while operating the UVGSHs at full and partial input at low ventilation rates. Although obviously not true for every heater, on average for every pollutant measured (except CO₂), the emission rate (the mass of pollutant per caloric value of fuel consumed) was lower during partial input operation than during full input operation. This finding is significant for two reasons: (1) pollutant emissions per unit of time can thereby often be reduced even beyond the reduction associated with lowering fuel consumption, and (2) manufacturers may have optimized the natural gas flow of some burners to increase heat output without regard for pollutant emissions.

Tuning Tests

The variability of CO emissions prompted a series of tests on the sensitivity of emission rates to adjustments of the air shutter. All heaters had previously been tuned with a portable CO analyzer and inspected visually for flame characteristics. With adjustment of the air shutter as the only variable, we measured peak CO, NO₂, and NO concentrations from heater 30A, after combusting 5 ft³ of natural gas under constant ventilation conditions (0.4 ach). The results of these tests are shown in Figure 13. This plot is similar to an emission versus air/fuel ratio plot with the abscissa representing the percent opening of the air shutter. Throughout the range of shutter settings depicted, 0 to 42% of fully open, the visual flame characteristics are good. The flame characteristics begin to deteriorate only when the shutter is opened beyond 42%. With the air-shutter opening increased from 21% to 32% of full open, the CO concentration increased by a factor of nine. This increase in the air-shutter opening required less than a 10 degree rotation of the shutter, underscoring the sensitivity of CO emissions to tuning.

Although NO_x emissions are not as sensitive to tuning, (see Figure 13), in the excess primary air regime (air shutter open more than 21%) the NO_2 -to- NO ratio appears to be extremely sensitive to tuning--increasing from 0.3 at a 21% opening to greater than 300 at a 42% opening with virtually all NO_x in the form of NO_2 . Figure 13 also illustrates that, as expected, NO_x emissions are at a maximum very near the CO minimum. (The production of NO_x is primarily a function of local flame temperature, and the flame is hottest, to a first approximation, when combustion is complete.)

The NO_2 emissions are moderately sensitive to the air shutter adjustment, varying by a factor of two when the air shutter is varied from 0% to 42% of full open. The NO_2 emissions are at a minimum near the CO minimum and peak in the excess air regime when the shutter is about 35% open.

After applying the knowledge obtained from the tuning curve, heater 30A shifted from being one of the highest CO-emitting heaters to one of the four lowest. The three other low CO-emitting heaters (20C, 30C, 40C), all from the same manufacturer, were also among the lowest emitters of HCHO and NO_x . In contrast to emission rate test results for the 30A, these heaters were found to be relatively insensitive to tuning. This insensitivity is illustrated by the results in Table 12 which compares emission rates from the 30A and 40C heaters under two conditions, one with the air shutter fully opened and one with the shutter fully closed. Manufacturer C incorporates a very different burner design in its heaters compared to the other two manufacturers. Instead of having many small circular ports in a flat, rectangular burner that produce many small "flamelets," this burner has relatively few slots cut across a cylindrically-shaped burner which produce a softer "feathered" flame. It is likely that this burner design accounts for both the lower emission rates and insensitivity to tuning.

Steady-state Tests

One concern that developed during the course of the study was whether pollutant emission rates determined from short-duration operation of the heaters at O_2 levels between 20 and 21% could be used as a basis for predicting concentrations from longer term operation of the heaters and from their operation in an O_2 -deficient environment. In this connection, it should be noted that the CO concentration profiles from heater 12A (see Tests 16, 17, and 19 in the Appendix) and perhaps to a lesser extent, heaters 20A and 20C in Tests 4, 5, and 6 exhibited an abrupt change in the slope during the portion of the profile corresponding to when the heater was operating. This could indicate a change in the CO emission rate as the heater warms up or it could indicate that for a small heater (and the 12A heater was the smallest heater in the study) there is a delay before convectively-induced mixing occurs. However, a change in the slope of the CO concentration profile was not observed for the 16B, while operating at an even lower input -- 9,100 Btu/h (9,600 kJ/h).

Ultimately, the second phase of this study, the controlled field study of pollutant concentrations produced by these heaters in a research house, should demonstrate whether emission rates determined from short-term tests can be successfully applied to longer term operation of these heaters under realistic conditions. However, to address this concern, a series of steady-state tests were run on three heaters, one from each manufacturer, at different O_2 levels. During these tests the ventilation of the chamber was adjusted and the heater operated long enough (except as indicated) to obtain steady-state levels of the gases monitored: O_2 ; CO_2 ; CO; NO; and NO_2 . In general, measurements during steady-state tests were made after the heaters had operated for several hours with a minimum operating time prior to measurement of one half hour. Unlike the dynamic tests when only traces of condensation were present, during the steady state tests large amounts of condensation were often present. To calculate the ventilation rate, the measured CO_2 and O_2 concentrations were used in Equation 9, along with the chamber

volume and the respective source strengths as determined from short-duration tests for the specific heater under well-tuned conditions (see Table 4). These ventilation rates, developed from CO₂ and O₂, are listed in Table 13. While the two ventilation rates derived from CO₂ and O₂ measurements had an average relative standard deviation of less than 9%, some ventilation rates differed by as much as 30%, especially at high ventilation rates, and for this reason the CO₂- and O₂-derived ventilation rates were averaged for these steady-state tests. The average ventilation rate was used in Equation 8 or 9, as appropriate, with the source strengths for CO, NO, NO₂ and NO_x as previously determined from short duration tests (see Table 4), the chamber volume and, when appropriate, the reactive decay constant to calculate "predicted" steady-state concentrations. The reactive decay constants used for these calculations were 0.00 h⁻¹ for NO, 0.31 h⁻¹ for NO₂, and 0.11 h⁻¹ for NO_x as determined from previous chamber experiments. The dynamic-test emission rates were determined near room temperature while the steady-state concentrations were typically measured at higher temperatures. However because the temperature correction was 5% or less, it was not applied to the calculated concentrations.

These calculated concentrations are compared in Table 13 with the observed concentrations minus backgrounds for the three heaters. The difference between calculated and observed concentrations for CO₂ and O₂ reflects, in part, the error in the calculated ventilation rate. For heater 16B, a high CO-emitter, there is good agreement between calculated and observed concentrations for all pollutants except NO and NO_x and, even in these cases, the disparity occurs only for the tests run at 18% and 19% O₂. We are unable to explain this lack of agreement.

The other two heaters were low CO-emitting heaters. For the 30C, observed and calculated concentrations of NO differed significantly only for the test run at 18% O₂. Not only were the observed CO concentrations low, but accurate measurement was further complicated by the high and variable CO backgrounds of 3.5 to 4.6 ppm (which caused a negative CO concentration for the 20% O₂ test when the background was subtracted).

However, while the relative error in CO concentrations was large for the 19% and 20% O₂ tests, the actual error was only a few ppm of CO even in the worst case. The agreement for all other pollutants was good.

The remaining heater, the 30A, was tested while well tuned only at the 18% O₂ level. For all pollutants, calculated concentrations were generally higher than observed concentrations in this single test. A review of the test data for this heater indicates that pollutants other than CO₂ may not have reached steady state. Although the ventilation rate for the chamber had been set some time earlier and the heater was operating for a relatively long time, because the air shutter was being adjusted periodically, the concentrations of pollutants other than CO₂ may not have had time to reach steady state. (The O₂ concentration appeared to be at steady state.)

To account for the effect that different O₂ levels may have on heaters with poorly adjusted air shutters, we conducted additional steady-state tests on these three heaters. In these tests, the heaters were operated at one of two or three O₂ levels while varying the air shutter. The resulting concentrations minus background concentrations for O₂, CO, CO₂, NO, NO₂, and NO_x are listed in Tables 14, 15, and 16. As an emission rate index, we also list the volumetric ratio of the change in CO to the change in O₂, because it removes the effect of changes in the ventilation rate and reveals changes occurring in CO emissions alone.

For the 30A, the CO concentrations at 18% O₂, as expected, are higher than those at 20% O₂ for any given shutter setting. With a closed shutter (shutter opening, 0%), the emission rate index is higher at 18% O₂ than at 20% O₂. At shutter openings of 47 and 52% the index is much lower at 18% O₂ than it was at 20% O₂, indicating several important facts about the 30A: its emissions are very sensitive to the air shutter adjustment; it can be a high or low CO-emitting heater; and its emission rate can either increase or decrease as the O₂ level decreases, depending upon its original air shutter setting. Referring back to Figure 13,

developed from tests on this heater, when this heater is operated with a shutter opening of less than about 15%, as the level of O_2 is decreased the heater will emit more CO since it is operating in the O_2 -deficient region. When the heater was operated with excess air (shutter open more than about 21%) decreasing the O_2 level also decreased the emission rate index. It is not apparent just how this reduction is related to tuning and O_2 levels. However, it is obvious from the test results that even though CO concentrations do increase as the O_2 levels decrease, high concentrations of CO can result from operation of these heaters even when the O_2 level is 20%.

The CO concentrations produced by the 16B and the 30C also increased as the O_2 level decreased for any given air shutter setting. The emission rate index for the 16B changed very little, indicating that most of the increase in CO concentration was due to the change in the ventilation rate and not in combustion characteristics. Moreover, pollutant emission rates from this heater were not very sensitive to adjustment of the air shutter. This heater, as is evident from the emission rate index, was a persistently high CO-emitter.

In contrast, the 30C was a persistently low CO-emitter despite being somewhat more sensitive to air-shutter adjustment and O_2 level.

A Perspective on Pollutant Emission Rates for UVGSH

While it is impossible to describe all the conditions of use for unvented gas-fired space heaters and all environments where they are used, a simple example illustrates the indoor concentrations of pollutants that might result from their use. This example will not represent a "worst case" scenario. With the exception of the length of operation when operated at steady state, all conditions of use -- the heater size, the emission rates, the size of the heated space, and the ventilation rate -- are moderate. Instead the example will lend perspective about the pollutant concentrations one might expect from specific emission rates.

Let us assume that the heater is used in a 130 m^2 (1400 ft^2) house with a 2.4-m (8-ft) ceiling with well-mixed interior air; all outdoor pollutant concentrations are zero; the air exchange rate for the house is 1 ach, somewhat higher than the U.S. average⁴; and the unvented gas-fired space heater used is a well-tuned 21,100 kJ/h (20,000 Btu/h) heater. The heater is operated at full input for a fairly long time (in accordance with manufacturers' recommendations that these particular models be operated only at full input and sized according to house volume and climatic zone). In all cases, the emission rate used is the mean of the eight heaters under well-tuned conditions (see Tables 4 and 11): for NO_2 , $13.9 \text{ } \mu\text{g/kJ}$; for CO_2 , $51,100 \text{ } \mu\text{g/kJ}$; for CO , $34 \text{ } \mu\text{g/kJ}$; and for HCHO , $0.81 \text{ } \mu\text{g/kJ}$. Unlike CO and CO_2 , both NO_2 and HCHO are reactive gases and this reactivity would reduce the actual concentrations observed. In an extensively tested research house, NO_2 was observed to have a reactive decay constant of 1.3 h^{-1} .⁵ The reactive decay constant of HCHO -- 0.4 h^{-1} --was measured in our environmental chamber.¹ While it is unknown whether either of these values would apply to other environments, for the purpose of our example we will assume they do.

Ideally, the pollutant concentrations from this example should be evaluated against established indoor air quality guidelines or standards. However, no national non-occupational indoor air quality standards exist in the United States for the pollutants measured. Because of this lack of standards and guidelines, the pollutant concentrations from this example will be compared to outdoor air quality standards and occupational air standards.

With these assumptions and conditions we can proceed using Equation 3 as written previously. After one hour of continuous operation, the HCHO concentration would be 24 ppb, the CO concentration would rise above 1 ppm, the NO_2 concentration would be 0.196 ppm, and the CO_2 concentration would be 1200 ppm. Even if the heater were operated continuously under these conditions, the steady-state HCHO concentration would increase to 32 ppb, less than the most stringent indoor guideline for HCHO , 100 ppb.⁶ The steady-state CO concentration of 2 ppm would be much

lower than EPA's outdoor long-term (eight-hour) standard of 9 ppm.⁷ The steady-state NO₂ concentration from this well-tuned heater (recall that NO₂ is only one-fourth of NO_x) would be 0.217 ppm, 86% of the California short-term (one-hour) outdoor standard of 0.25 ppm.⁸ It is not clear from this example whether repeated exposures to such NO₂ concentrations would be sufficient to cause an individual's exposure to exceed the EPA long-term (annual) outdoor standard for NO₂ of 0.05 ppm⁹. CO₂, at 1890 ppm, approaches but does not exceed the ASHRAE guideline of 2500 ppm.⁶

In the above example, note that the pollutant concentrations calculated are specific to the size of the heater, its state of tuning, the length of operation, the volume of the heated space, and the ventilation rate. It is apparent that the potential for CO and HCHO concentrations to reach problem levels in an indoor environment depends very much on the volume of the heated space and the ventilation rate, as well as the heater-specific factors listed above. This is not the case with NO₂; NO₂ concentrations are likely to reach a significant fraction of existing outdoor standards under a wide range of conditions.

In contrast to the previous example which used average emission rates, in Table 17 we present a list of specific heaters, both well tuned and poorly tuned, for which we calculated steady-state pollutant concentrations from the emission rates specific to each heater (see Tables 4 and 12). (The assumptions of a 317 m³ (11,200 ft³) house at 1 ach with well-mixed air and appropriate decay constants remained.)

For the well-tuned heaters, most results are similar to the previous example, i.e., NO₂ concentrations remained high and HCHO concentrations low. For two of these well-tuned heaters, CO concentrations approach the EPA eight-hour outdoor standard of 9 ppm;⁷ CO₂ concentrations are high relative to the ASHRAE standard⁶ and, as expected, scale with heater input. O₂ levels do not fall below 20.2% (assuming an outside O₂ concentration of 20.9%).

In the case of the poorly tuned heaters, NO₂ concentrations remain largely unchanged -- that is, still high compared with guidelines. The HCHO concentration, however, varies under different conditions, e.g., in the 30A with an open shutter, it is quite high. CO concentrations in these heaters are also highly variable and, as shown, can approach U.S. OSHA's eight-hour standard of 50 ppm¹⁰ and exceed EPA's outdoor standards. (The emissions from the 40C heater, stated previously, are remarkably insensitive to tuning.)

However, it should be noted that in the above examples the pollutants are assumed to be distributed throughout the home. If, for example, a heater were used in a room with an interior door only partially open, the pollutant concentrations would be elevated.

CONCLUSIONS

In the laboratory, we have measured the emission rates for CO, CO₂, NO, NO₂, HCHO, and submicron particles emitted by unvented gas-fired space heaters and the consumption rate of O₂. Particulate emission rates were found to be uniformly low and NO₂ emission rates uniformly high relative to their ability to elevate pollutant levels to concentrations approaching air quality guidelines. HCHO emissions while generally low, can be high in specific heaters, particularly those that are poorly tuned. CO emission rates are highly variable and, depending on the burner design and the state of tuning, can be quite high. CO₂ emissions per unit of time can also be high depending on the fuel consumption rate of the heater. High CO₂ concentrations may be of concern both because of the intrinsic health effects and their effect on increasing respiratory rates, i.e., increased respiration increases the dose occupants may receive from other pollutants. This consideration underscores the need to assess the health effects of all pollutant emissions in concert, rather than on a pollutant-by-pollutant basis.

It also appears that pollutant emission rates obtained from short-term dynamic tests can be successfully applied to steady-state conditions (and even to operation at O_2 levels as low as 18%). We expect that our controlled field study, the second phase of this project, will confirm these laboratory findings.

We have demonstrated that proper tuning of the heaters (by adjustment of the air shutter) is critical with respect to their emissions of CO, NO, NO_2 and HCHO. In addition to indicating the importance of tuning, these tests also demonstrate that steady-state O_2 concentrations alone are poor predictors of steady-state CO concentrations.

On the other hand, one of the three manufacturers represented in this study uses a different burner design from the others, and tests on these heaters show them to be insensitive to tuning and lower in pollutant emissions than the heaters from the other two manufacturers. From these findings, we conclude that improvements in burner design should be pursued. In this connection, tests of heaters operating at partial input indicated that lower pollutant emission rates often result from the lower flows of natural gas to the burner under these operating conditions. Burner designs might be modified to take advantage of this.

Our laboratory studies indicate that unvented gas-fired space heaters can produce sufficiently high concentrations of pollutants to be of concern when compared to existing guidelines, both in single-room environments and, based on calculations, have the potential to produce sufficiently high concentrations to be of concern in residential-sized buildings. Although our findings suggest that these heaters can pose a health risk when used in spaces where ventilation is reduced, the NO_2 emissions may be high enough to warrant concern even under relatively high ventilation conditions. These findings underscore the need for careful review of the use of these appliances in terms of health risk.

Finally, if we are to determine the degree to which occupants are exposed to combustion-generated pollutants and thus the risk to occupants, we need information on the distribution of (1) appliance usage patterns by consumers, (2) use conditions such as air-shutter settings of the heaters as actually used by consumers, and (3) such characteristics as heated volumes and ventilation rates where heaters are used. The foregoing data are not presently available. A survey of this type should be supplemented by field studies to amass data on pollutant concentrations in a variety of indoor environments and over a wide range of usage patterns.

ACKNOWLEDGEMENTS

This work was supported by the Director, Office of Energy Research, Office of Health and Environmental Research, Human Health and Assessments Division of the U.S. Department of Energy under Contract No. DE-AC03-76SF00098, and by the Directorate for Health Sciences, of the U.S. Consumer Products Safety Commission under Contract No. CPSC-IAG-81-1375. This paper reflects the views of the authors and not necessarily those of the supporting agencies.

The authors also wish to acknowledge the contributions of several members of the CPSC staff, Dr. Rita Orzel, Sid Greenfeld, and Paul White. Our many, extensive discussions with them were extremely useful and beneficial to the study. We would also like to acknowledge the contributions of several members of the LBL staff: Laurel Cook for her assistance in editing the text; Nancy Morrison for word processing the text and tables; Andy Carruthers for his assistance in data reduction; Buck Koonce, Lloyd David and Al Robb for their assistance in fabrication of necessary equipment; Jim Dillworth for his advice on statistical problems; and David Grimsrud and Bill Nazaroff for reviewing the report.

REFERENCES

1. Traynor, G.W., Anthon, D.W., and Hollowell, C.D., Technique for Determining Pollutant Emissions from a Gas-Fired Range, Atmospheric Environment 16, 2979 (1982).
2. Himmel, R.L. and Dewerth, D.W., Evaluation of the Pollutant Emissions from Gas-fired Ranges, Report No. 1492, American Gas Association Laboratories, Cleveland, Ohio (1974).
3. Dockery, D.W., Spengler, J.D., Reed, M.P., and Ware, J., Relationships among Personal, Indoor and Outdoor NO₂ Measurements, Environment International 5, 101(1981).
4. Grimsrud, D.T., Sherman, M.H., and Sonderegger, R.C., Calculating Infiltration: Implication for a Construction Quality Standard, Lawrence Berkeley Laboratory Report LBL-9416, Berkeley, CA (1982).
5. Traynor, G.W., Apte, M.G., Dillworth, J.F., Hollowell, C.D., and Sterling, E.M., The Effect of Ventilation on Residential Air Pollution Due to Emissions from a Gas-fired Range, Environment International 8, 447 (1982).
6. American Society of Heating, Refrigerating, and Air-conditioning Engineers, Ventilation for Acceptable Indoor Air Quality, ASHRAE 62-1981, Atlanta, GA (1981).
7. U.S. Government, Code of Federal Regulations, Title 40, Section 50.8 (1979).
8. State of California, California Administrative Code, Title 17, Subchapter 1.5, Section 70100, Sacramento, CA (1977).
9. U.S. Government, Code of Federal Regulations, Title 40, Section 50.11 (1979).

10. U.S. Government, Code of Federal Regulations, Title 29, Section
1910.1000 (1979).

Table 1. Instrumentation for gas appliance emission testing.

Purpose	Method/Instrument	Ranges	Precision	Manufacturer/Model
<u>Continuous monitoring of the following parameters:</u>				
Fuel Metering	Diaphragm gas meter	5-425 L/min	± 1%	Singer AL-425
Gas				
CO ₂	NDIR	0-2.5%	± 1% full scale	MSA Lira 303
CO	NDIR	0-50 ppm	± 1% full scale	Bendix 8501-5SCA
NO, NO ₂ , NO _x	Chemiluminescence	0-5 ppm, 0-10 ppm	± 1% full scale	Thermo Electron 14D
O ₂	Paramagnetism	16%-21%	± 1% full scale	Beckman 755
<u>Time averaged monitoring:</u>				
HCHO	Refrigerated Bubblers Colorimetry	---	± 15% ^a	LBL ^{b,c}
Particles (0.0056-0.562 μm)	Electrical Mobility	0-1000 μg/m ³	--- ^d	Thermo Systems Inc. Model 3030
<u>Temperature & Humidity:</u>				
Dry bulb Temperature	Thermistor	0-50°C	± 0.4°C	Yellow Springs Inc. 701/LBL
Dewpoint Temperature	Lithium Chloride Probe	-12°C to +42°C	± 0.5°C	Yellow Springs Inc. 91 HC/LBL
<u>Data Acquisition:</u>				
Gases, Temperature, Dewpoint, Sampling Locator	Microprocessor Multiplexer A/D			Intel System 80/20-4 Burr Brown Micromux Receiver MM6016AA Remote MM6401
Particles	Tape Drive Microprocessor A/D			Columbia Data Products 300D LBL

^aEstimate

^bMiksch, R.R., Anthon, D.W., Fanning, L.Z., Hollowell, C.D., Revzan, K., and Glanville, J., (1981) "Modified Pararosaniline for the Determination of Formaldehyde in Air," Anal. Chem., 53, 2118.

^cFanning, L.Z., Allen, J.R., and Miksch, R.R., (1980) "Instructions for Operating LBL Formaldehyde Sampler," Lawrence Berkeley Laboratory Report No. LBL-10629, Berkeley, CA.

^dNA

Table 2. Reproducibility of pollutant emission rates from tests of unvented gas-fired space heaters.

Heater ^a	Test No.	Air Exchange Rate (h ⁻¹)	Fuel Consumption (kJ/h)	CO (µg/kJ)	CO ₂ (µg/kJ)	NO (µg/kJ)	NO ₂ (µg/kJ)	N (of NO _x) (µg/kJ)	O ₂ (µg/kJ)	HCHO (µg/kJ)	Particles ^b (µg/kJ)
12A	16	0.5	10,300	193	48,400	5.8	22.8	9.6	-67,400	6.1	0.34
	17	0.4	10,100	60	51,200	12.1	17.3	10.9	-66,400	3.2	0.30
	19	0.5	10,100	89	50,400	10.8	19.0	10.8	-68,500	3.3	0.31
20A	4	0.7	22,900	16	50,300	24.3	12.2	15.1	-73,000	0.36	0.10
	5	0.7	23,900	58	52,600	22.4	9.3	13.3	-70,200	0.24	0.034
30A ^c	37	0.4	33,900	566	41,200	0.031	9.1	2.8	-56,000	15	<0.004
	38	0.4	34,300	516	43,500	0.040	11.5	3.5	-57,900	20	<0.004
16B ^c	24	4.2	17,000	341	52,700	10.5	30.3	14.1	-75,000	4.1	0.021
	25	4.5	16,900	344	51,800	10.9	31.5	14.7	-70,700	4.1	0.018
	26	4.5	17,000	312	50,000	10.5	25.7	12.7	-73,300	2.1	<0.004
40B	15	0.4	44,000	67	51,100	14.4	24.3	14.1	-70,300	1.1	<0.004
	18	0.4	45,000	60	50,900	18.7	16.4	13.7	-68,000	0.86	0.008
40C	8	0.6	44,000	18	53,400	16.9	11.1	11.2	-70,800	0.69	0.023
	9	0.9	42,100	9	55,800	21.1	9.0	12.6	-71,800	0.53	0.006
40C ^d	32	1.1	25,200	9	51,600	13.4	7.2	8.4	-66,400	0.24	<0.004
	31	2.0	23,800	15	48,100	12.7	6.6	7.9	-61,600	0.31	<0.004

^aIdentification code: 40B = 40,000 Btu/h (42,200 kJ/h) heater rating from manufacturer B. Heat content of the natural gas used was 31.4 kJ/L.

^bMass of particles from 0.0056 to 0.56 µm in diameter analyzed by an electrical mobility detector assuming a particle density of 2.0 g/cm³.

^cTests of poorly tuned heaters.

^dPartial input tests.

Table 3. Comparison of pollutant emission rates ($\mu\text{g}/\text{kJ}$) and oxygen consumption rates ($\mu\text{g}/\text{kJ}$) obtained from an unvented gas-fired space heater combusting either 5 ft^3 or 10 ft^3 of natural gas.

Species	5 ft^3	10 ft^3
CO_2	51,900	46,500
O_2	-75,600	-65,300
CO	4.7	7.5
NO	20.2	17.4
NO_2	5.6	6.6
$\text{N}(\text{NO}_x)$	11.1	10.1
HCHO	0.35	0.22
Particles ^a	0.065	0.10

^aMass of particles from 0.0056 to 0.56 μm in diameter analyzed by an electrical mobility detector assuming a particle density of 2.0 g/cm^3 .

Table 4. Pollutant emission rates from eight well-tuned, unvented gas-fired space heaters operated at full input in an environmental chamber with low ventilation.

Heater ^a	Percent of Rated Input	Shutter Setting ^b (%)	No. of Tests	Air Exchange Rate (h ⁻¹)	CO (µg/kJ)	NO (µg/kJ)	NO ₂ (µg/kJ)	N (of NO _x) (µg/kJ) ^x	CO ₂ (µg/kJ)	O ₂ (µg/kJ)	HCHO (µg/kJ)	Particles ^c (µg/kJ)
12A	80	25	3	0.5	114	9.6	19.7	10.5	50,000	-67,400	4.2	0.32
20A	108	26	3	0.7	29	22.5	12.9	14.4	50,100	-71,700	0.61	0.039
30A ^d	112	18	1	0.6	25	21.7	11.4	13.6	49,900	-72,900	0.59	0.006
16B	106	66	1	0.5	165	13.9	18.1	12.0	51,500	-71,900	0.55	0.049
40B	106	97	2	0.4	63	16.5	20.4	13.9	51,000	-68,900	0.96	0.009
20C	108	98	2	0.4	14	16.2	10.9	10.9	50,100	-73,700	0.91	0.079
30C	101	90	1	0.6	11	19.3	9.6	11.9	52,600	-73,700	0.43	0.064
40C	102	63	2	0.7	13	19.0	10.0	11.9	54,600	-71,000	0.61	0.024

^aIdentification code: 40B = 40,000 Btu/h (42,200 kJ/h) heater rating from manufacturer B. Heat content of the natural gas used was 31.4 kJ/L.

^bPercent of full open.

^cMass of particles from 0.0056 to 0.56 µm in diameter analyzed by an electrical mobility detector, assuming a particle density of 2.0 g/cm³.

^dHeater subjected to extensive tuning and considered optimally tuned.

Table 5. Pollutant emission rates from three well-tuned, unvented gas-fired space heaters operated at full input in an environmental chamber with moderate ventilation.

Heater ^a	Percent of Rated Input	Shutter Setting ^b (%)	No. of Tests	Air Exchange Rate (h ⁻¹)	CO (µg/kJ)	NO (µg/kJ)	NO ₂ (µg/kJ)	N (of NO _x) (µg/kJ) ^x	CO ₂ (µg/kJ)	O ₂ (µg/kJ)	HCHO (µg/kJ)	Particles ^c (µg/kJ)
30A ^d	113	18	1	1.0	23	21.1	10.0	12.9	51,100	-67,500	0.62	<0.004
16B	105	66	1	1.1	287	10.1	26.3	12.7	53,200	-73,000	2.4	0.058
40C	100	63	1	1.1	10	18.3	9.4	11.4	52,000	-68,600	0.72	0.020

^aIdentification code: 40C = 40,000 Btu/h (42,200 kJ/h) heater rating from manufacturer C. Heat content of the natural gas used was 31.4 kJ/L.

^bPercent of full open.

^cMass of particles from 0.0056 to 0.56 µm in diameter analyzed by an electrical mobility detector, assuming a particle density of 2.0 g/cm³.

^dHeater subjected to extensive tuning and considered optimally tuned.

Table 6. Pollutant emission rates from three well-tuned, unvented gas-fired space heaters operated at full input in an environmental chamber with high-ventilation.

Heater ^a	Percent of Rated Input	Shutter Setting ^b (%)	No. of Tests	Air Exchange Rate (h ⁻¹)	CO (µg/kJ)	NO (µg/kJ)	NO ₂ (µg/kJ)	N (of NO _x) (µg/kJ) ^x	CO ₂ (µg/kJ)	O ₂ (µg/kJ)	HCHO (µg/kJ)	Particles ^c (µg/kJ)
30A ^d	111	18	1	5.1	23	23.6	13.2	15.0	53,000	-75,900	0.83	0.004
16B	101	66	3	4.3	332	10.5	25.7	12.7	50,000	-73,000	3.4	0.019
40C	102	63	1	4.5	12	22.0	9.7	13.2	50,600	-71,000	0.34	0.026

^aIdentification code: 40C = 40,000 Btu/h (42,200 kJ/h) heater rating from manufacturer C. Heat content for the natural gas used was 31.4 kJ/L.

^bPercent of full open.

^cMass of particles from 0.0056 to 0.56 µm in diameter analyzed by an electrical mobility detector, assuming a particle density of 2.0 g/cm³.

^dHeater subjected to extensive tuning and considered optimally tuned.

Table 7. Pollutant emission rates from eight well-tuned, unvented gas-fired space heaters operated at partial input in an environmental chamber with low ventilation.

Heater ^a	Percent of Rated Input	Shutter Setting ^b (%)	No. of Tests	Air Exchange Rate (h ⁻¹)	CO (µg/kJ)	NO (µg/kJ)	NO ₂ (µg/kJ)	N (of NO _x) (µg/kJ) ^x	CO ₂ (µg/kJ)	O ₂ (µg/kJ)	HCHO (µg/kJ)	Particles ^c (µg/kJ)
12A	51	25	1	0.3	11	12.5	7.8	8.2	53,900	-68,300	0.06	<0.004
20A	52	26	1	0.3	20	14.0	11.3	10.0	51,400	-65,700	0.65	<0.004
30A ^d	57	18	1	0.3	17	15.4	12.4	11.0	52,400	-75,200	1.7	<0.004
16B	57	66	1	0.4	87	11.0	13.7	9.3	50,900	-68,900	2.6	<0.004
40B	55	97	1	0.3	9	15.4	9.9	10.2	52,000	-75,300	0.30	<0.004
20C	53	98	1	0.4	18	9.9	10.5	7.8	52,800	-67,900	0.46	0.009
30C	44	90	1	0.3	16	11.9	9.1	8.3	53,200	-74,000	0.90	0.019
40C	64	63	1	0.2	9	13.8	7.1	8.6	50,300	-69,300	0.24	<0.004

^aIdentification code: 40B = 40,000 Btu/h (42,200 kJ/h) heater rating from manufacturer B. Heat content of the natural gas used was 31.4 kJ/L.

^bPercent of full open.

^cMass of particles from 0.0056 to 0.56 µm in diameter analyzed by an electrical mobility detector, assuming a particle density of 2.0 g/cm³.

^dHeater subjected to extensive tuning and considered optimally tuned at full input.

Table 8. Pollutant emission rates from three well-tuned, unvented gas-fired space heaters operated at partial input in an environmental chamber with moderate ventilation.

Heater ^a	Percent of Rated Input	Shutter Setting ^b (%)	No. of Tests	Air Exchange Rate (h ⁻¹)	CO (µg/kJ)	NO (µg/kJ)	NO ₂ (µg/kJ)	N (of NO _x) (µg/kJ)	CO (µg/kJ)	O ₂ (µg/kJ)	HCHO (µg/kJ)	Particles ^c (µg/kJ)
30A ^d	69	18	1	1.6	6	18.2	7.6	10.8	48,600	-72,800	0.18	<0.004
16B	54	66	1	0.8	124	13.5	12.0	10.0	55,300	-70,400	0.27	<0.004
40C	58	63	2	1.6	12	13.1	6.9	8.2	49,900	-64,000	0.27	<0.004

^aIdentification code: 40C = 40,000 Btu/h (42,200 kJ/h) heater rating from manufacturer C. Heat content of the natural gas used was 31.4 kJ/L.

^bPercent of full open.

^cMass of particles from 0.0056 to 0.56 µm in diameter analyzed by an electrical mobility detector, assuming a particle density of 2.0 g/cm³.

^dHeater subjected to extensive tuning and considered optimally tuned at full input.

Table 9. Pollutant emission rates from three well-tuned, unvented gas-fired space heaters operated at partial input in an environmental chamber with high ventilation.

Heater ^a	Percent of Rated Input	Shutter Setting ^b (%)	No. of Tests	Air Exchange Rate (h ⁻¹)	CO (µg/kJ)	NO (µg/kJ)	NO ₂ (µg/kJ)	N (of NO _x) (µg/kJ) ^x	CO ₂ (µg/kJ)	O ₂ (µg/kJ)	HCHO (µg/kJ)	Particles ^c (µg/kJ)
30A ^d	39	18	1	3.6	16	13.3	8.2	8.7	49,100	-62,800	0.87	<0.004
16B	60	66	1	3.5	93	14.8	17.6	12.3	47,500	-67,300	1.5	<0.004
40C	37	63	1	5.0	12	10.3	8.0	7.2	49,000	-90,700	1.3	<0.004

^aIdentification code: 40C = 40,000 Btu/h (42,200 kJ/h) heater rating from manufacturer C. Heat content of the natural gas used was 31.4 kJ/L.

^bPercent of full open.

^cMass of particles from 0.0056 to 0.56 µm in diameter analyzed by an electrical mobility detector, assuming a particle density of 2.0 g/cm³.

^dHeater subjected to extensive tuning and considered optimally tuned at full input.

Table 10. Selected pollutant emission rates from three unvented gas-fired space heaters operating at full input in a chamber with different ventilation rates.

Heater ^a	CO ($\mu\text{g}/\text{kJ}$)			NO ₂ ($\mu\text{g}/\text{kJ}$)		
	Ventilation			Ventilation		
	Low	Moderate	High	Low	Moderate	High
30A ^b	25	23	23	11.4	10.0	13.2
16B	165	287	332	18.1	26.3	25.7
40C	13	10	12	10.0	9.4	9.7

^aIdentification code: 40C = 40,000 Btu/h (42,200 kJ/h) heater rating from manufacturer C. Heat content of the natural gas used was 31.4 kJ/L.

^bHeater subjected to extensive tuning and considered optimally tuned.

Table 11. Pollutant emission rates from eight well-tuned unvented gas-fired space heaters operated at full and partial input in a chamber with low ventilation.

Heater ^a	CO (µg/kJ)		NO (µg/kJ)		NO ₂ (µg/kJ)		N (of NO _x) (µg/kJ)		HCHO (µg/kJ)		Particles ^b (µg/kJ)	
	partial	full	partial	full	partial	full	partial	full	partial	full	partial	full
12A	11	114	12.5	9.6	7.8	19.7	8.2	10.5	0.06	4.2	<0.004	0.32
20A	20	29	14.0	22.5	11.3	12.9	10.0	14.4	0.65	0.61	<0.004	0.039
30A ^c	17	25	15.4	21.7	12.4	11.4	11.0	13.6	1.7	0.59	<0.004	0.006
16B	87	165	11.0	13.9	13.7	18.1	9.3	12.0	2.6	0.55	<0.004	0.049
40B	9	63	15.4	16.5	9.9	20.4	10.2	13.9	0.30	0.96	<0.004	0.009
20C	18	14	9.9	16.2	10.5	10.9	7.8	10.9	0.46	0.91	0.009	0.079
30C	16	11	11.9	19.3	9.1	9.6	8.3	11.9	0.90	0.43	0.019	0.064
40C	9	13	13.8	19.0	7.1	10.0	8.6	11.9	0.24	0.61	<0.004	0.024
Average	17 ^d	34 ^d	13.0	17.3	10.6	14.1	9.2	12.4	0.52 ^d	0.81 ^d	<0.005 ^d	0.038 ^d
Average - std. dev.	8 ^e	12 ^e	11.0	13.1	7.8	9.6	8.0	11.0	0.16 ^e	0.40 ^e	-----	0.011 ^e
Average + std. dev.	36 ^e	95 ^e	15.0	21.6	13.4	18.6	10.3	13.8	1.7 ^e	2.5 ^e	-----	0.132 ^e

^aIdentification code: 40B = 40,000 Btu/h (42,200 kJ/h) heater rating from manufacturer B. Heat content of the natural gas used was 31.4 kJ/L.

^bMass of particles from 0.0056 to 0.56 µm in diameter analyzed by an electrical mobility detector assuming a particle density of 2.0 g/cm³.

^cHeater subjected to extensive tuning and considered optimally tuned at full input.

^dGeometric mean.

^eGeometric standard deviation.

Table 12. Pollutant emission rates from two poorly tuned, unvented gas-fired space heaters operated at full input in an environmental chamber with low ventilation.

Heater ^a	Percent of Rated Input	Shutter Setting ^b (%)	No. of Tests	Air Exchange Rate (h ⁻¹)	CO (µg/kJ)	NO (µg/kJ)	NO ₂ (µg/kJ)	N (of NO _x) (µg/kJ) ^x	CO ₂ (µg/kJ)	O ₂ (µg/kJ)	HCHO (µg/kJ)	Particles ^c (µg/kJ)
30A	108	100	1	0.4	517	0.04	11.5	3.5	43,500	-57,900	20.3	<0.004
40C	104	100	1	0.4	8	19.9	8.4	11.8	59,100	-66,200	0.49	<0.004
30A	106	0	1	0.4	159	15.1	13.7	11.2	52,500	-70,800	1.11	<0.004
40C	104	0	1	0.4	35	13.7	11.2	9.8	49,000	-67,200	0.22	0.007

^aIdentification code: 40C = 40,000 Btu/h (42,200 kJ/h) heater rating from manufacturer C. Heat content of the natural gas used was 31.4 kJ/L.

^bPercent of full open.

^cMass of particles from 0.0056 to 0.56 µm in diameter analyzed by an electrical mobility detector, assuming a particle density of 2.0 g/cm³.

Table 13. Measured and calculated steady-state concentrations minus background concentrations for three well-tuned, unvented gas-fired space heaters operating in a 27-m³ chamber at different oxygen levels.

O ₂ Level (%)	Gas	Air Exchange Rate ^b (h ⁻¹)		Concentration from Heater 30A ^a (ppm)		Air Exchange Rate ^b (h ⁻¹)		Concentration from Heater 16B ^a (ppm)		Air Exchange Rate ^b (h ⁻¹)		Concentration from Heater 30C ^a (ppm)	
		Measured ^c	Calculated	Measured ^c	Calculated	Measured ^c	Calculated	Measured ^c	Calculated	Measured ^c	Calculated		
20	O ₂		d			3.68		-10,100	-7,990	6.69		-9,970	9,730
	CO ₂		d			5.69		3,410	4,180	6.88		4,530	5,070
	CO		d					18.6	21.1			-1.3 ^e	1.67
	NO		d					1.47	1.66			3.48	2.81
	NO ₂		d					1.44	1.32			0.874	0.87
	NO _x		d					2.91	3.13			4.35	3.66
19	O ₂		d			1.87		19,900	-18,000	3.39		-19,400	19,400
	CO ₂		d			2.28		8,520	9,400	3.41		10,110	10,100
	CO		d					52.3	47.5			1.7 ^e	3.37
	NO		d					2.23	3.74			5.75	5.56
	NO ₂		d					2.78	2.76			1.61	1.65
	NO _x		d					5.02	7.07			7.36	7.36
18	O ₂	2.43	-29,500	-31,300	1.23	-30,200	28,500	2.23	28,500	2.23	28,500	28,900	
	CO ₂	2.53	15,460	16,300	1.39	13,970	14,900	2.33	15,460	2.33	15,460	15,100	
	CO		7.2 ^f	11.9		86.9	75.1		5.4		5.4	5.06	
	NO		6.62 ^f	9.60		3.00	5.91		6.64		6.64	8.34	
	NO ₂		2.63 ^f	2.92		3.91	4.05		2.05		2.05	2.39	
	NO _x		9.25 ^f	13.3		6.91	11.2		8.70		8.70	11.0	

^aIdentification code: 30A = 30,000 Btu/h (31,700 kJ/h) heater from manufacturer A.

^bVentilation rate used in calculating concentrations is average of ventilation rates derived from O₂ and CO₂ steady-state concentrations.

^cMeasured values are the average of approx. 10 data points one minute apart. The relative standard deviations about the mean were less than 5% except where indicated.

^dWell tuned heater not tested at this O₂ level.

^eBackground CO concentrations were very high -- 3.5 to 4.6 ppm. Relative standard deviations about the mean were less than 8%.

^fNear steady-state.

Table 14. Pollutant concentration increases above background from a 30,000 Btu/h unvented gas-fired space heater (30A) operating near steady state in a 27-m³ chamber. Measured values are the average of approximately 10 data points one minute apart. Relative standard deviations about the mean were less than 6% with the exception of the five near-zero Δ NO measurements.

Equilibrium O ₂ [%]	Shutter Opening [%]	Δ O ₂ [%]	Δ CO ₂ [ppm]	Δ CO [ppm]	Δ NO [ppm]	Δ NO ₂ [ppm]	Δ NO _x [ppm]	$-\Delta$ CO/ Δ O ₂ [ppm/%]
20	0	-1.11	5,660	2.6	3.48	1.12	4.50	2.3
	47	-1.04	5,340	75.5	0.00 ^a	2.03 ^a	2.03 ^a	73
	52	-1.07	5,500	90.9	0.01 ^a	2.37 ^a	2.38 ^a	85
18	0	-2.95	15,730	14.8 ^a	5.47 ^a	2.62 ^a	8.09 ^a	5.0
	18	-2.95	15,460	7.2 ^a	6.62 ^a	2.63 ^a	9.25 ^a	2.4
	47	-2.94	15,370	140 ^a	-0.02 ^a	3.68 ^a	3.67 ^a	48
	47	-2.99	15,580	138 ^a	-0.01 ^a	3.68 ^a	3.67 ^a	46
	52	-2.98	15,500	155 ^a	-0.02 ^a	2.37 ^a	2.38 ^a	52

^aNear steady-state.

Table 15. Pollutant concentration increases above background from a 16,000 Btu/h unvented gas-fired space heater (16B) operating near steady state in a 27-m³ chamber. Measured values are the average of 10 data points one minute apart. Relative standard deviations around the mean were less than 6%.

Equilibrium O ₂ [%]	Shutter Opening [%]	Δ O ₂ [%]	Δ CO ₂ [ppm]	Δ CO [ppm]	Δ NO [ppm]	Δ NO ₂ [ppm]	Δ NO _x [ppm]	-Δ CO/Δ O ₂ [ppm/%]
20	0	-0.90	4,860	31.8	1.66	2.04	3.70	35.3
	10	-0.92	4,860	25.9	1.81	1.97	3.77	28.0
	25	-1.02	5,070	35.0	1.50	1.99	3.49	34.3
	45	-1.06	4,760	28.6	1.69	1.80	3.49	27.0
	70	-0.76	4,700	31.5	1.91	2.02	3.97	41.4
	95	-1.01	3,410	18.6	1.47	1.44	2.91	18.4
19	0	-1.94	10,040	73.6	2.21	3.50	5.71	38.3
	10	-1.92	10,250	65.0	2.72	3.59	6.31	38.9
	25	-2.02	9,300	69.4	2.32	3.06	5.39	34.4
	45	-2.02	9,620	64.7	2.69	3.14	5.83	32.0
	70	-1.70 ^a	10,140 ^a	68.8 ^a	3.35 ^a	3.77 ^a	7.15 ^a	40.5 ^a
	95	-1.99	8,520	52.3	2.23	2.78	5.02	26.3
18	0	-2.90	15,420	115.2	2.45	4.57	7.02	39.7
	10	-2.91	15,900	119.6	2.44	4.77	7.21	41.1
	25	-3.05	14,480	108.9	2.74	4.06	6.80	35.7
	45	-3.02	15,380	106.5	3.10	4.43	7.53	35.3
	95	-3.02	13,970	86.9	3.00	3.91	6.91	28.8

^aDid not attain steady state. Concentration given is value obtained closest to steady state. No relative standard deviations were computed for these values.

Table 16. Pollutant concentration increases above background from a 30,000 Btu/h unvented gas-fired space heater (30C) operating near steady state in a 27-m³ chamber. Measured values are the average of approximately 10 data points one minute apart. Relative standard deviations about the mean were less than 6% except where indicated.

Equilibrium O ₂ [%]	Shutter Opening [%]	ΔO ₂ [%]	Δ CO ₂ [ppm]	Δ CO [ppm]	Δ NO [ppm]	Δ NO ₂ [ppm]	Δ NO _x [ppm]	-Δ CO/Δ O ₂ [ppm/%]
20	0	-0.94	4,860	5.9	2.42	1.21	3.63	6.3
	10	-0.99	4,990	4.6	2.52	1.07	3.59	4.7
	25	-0.87	4,660	3.3	2.42	1.07	3.50	3.8
	45	-0.91	4,710	2.0	3.03	1.07	4.10	2.2
	60	-0.88	4,760	2.1	3.14	0.98	4.12	2.3
	75	-0.84	4,160	3.0	2.96	0.80	3.76	3.6
	90	-1.00	4,530	-1.3 ^a	3.48	0.87	4.35	-1.3 ^a
19	0	-1.96	10,210	13.1	4.25	2.18	6.43	6.7
	10	-1.89	9,880	11.2	4.15	1.92	6.07	5.9
	25	-1.87	9,930	9.1	4.29	2.26	6.55	4.9
	45	-1.82	9,390	4.6	4.92	1.77	6.69	2.5
	60	-1.89	10,320	5.4	5.46	1.93	7.39	2.9
	75	-1.87	9,630	5.2	5.17	1.80	6.77	2.8
	90	-1.94	10,110	1.7 ^a	5.75	1.61	7.36	0.88 ^a
18	0	-2.93	15,490	23.1	5.01	2.98	7.99	7.9
	10	-2.87	15,400	20.5	4.94	2.65	7.59	7.1
	25	-2.87	15,390	17.9	4.81	3.15	7.96	6.2
	45	-2.84	16,400	11.0	6.14	2.54	8.70	3.9
	60	-2.87	16,290	10.6	6.71	2.42	9.13	3.7
	75	-2.87	15,410	6.3	6.34	2.13	8.47	2.2
	90	-2.85	15,460	5.4	6.64	2.05	8.70	1.9

^aExceptionally high background values for CO relative to ΔCO value -- 3.5 to 4.6 ppm. Relative standard deviations about the means of the ΔCO measurements were less than 8%.

Table 17. Calculated steady-state pollutant concentrations from specific unvented gas-fired space heaters operating continuously in a 1400 ft² (130 m²) house (1.0 ach) with well mixed air.

Heater ^a	CO ^b (ppm)	CO ₂ ^b (ppm)	O ₂ (%)	HCHO ^{b,c} (ppm)	NO ₂ ^{b,d} (ppm)
Well Tuned					
12A	3.2	880	20.7	0.080	0.13
16B	8.1	1,570	20.6	0.018	0.24
20C	0.9	2,000	20.5	0.039	0.18
30A	2.4	2,730	20.3	0.039	0.29
40B	7.8	4,000	20.2	0.081	0.67
40C	1.5	4,120	20.2	0.049	0.31
Poorly Tuned					
30A ^e	49	2,610	20.4	1.30	0.29
40C ^e	1.0	4,550	20.2	0.040	0.27
30A ^f	15	3,090	20.3	0.070	0.34
40C ^f	4.2	3,770	20.2	0.018	0.36

^aIdentification code: 40B = 40,000 Btu/h (42,200 kJ/h) heater rating from manufacturer B. Heat content of the natural gas used was 31.4 kJ/L.

^bBackground concentrations assumed to be zero.

^cA reactive decay constant of 0.4h⁻¹ was assumed.

^dA reactive decay constant of 1.3h⁻¹ was assumed.

^eFully open shutter.

^fFully closed shutter.

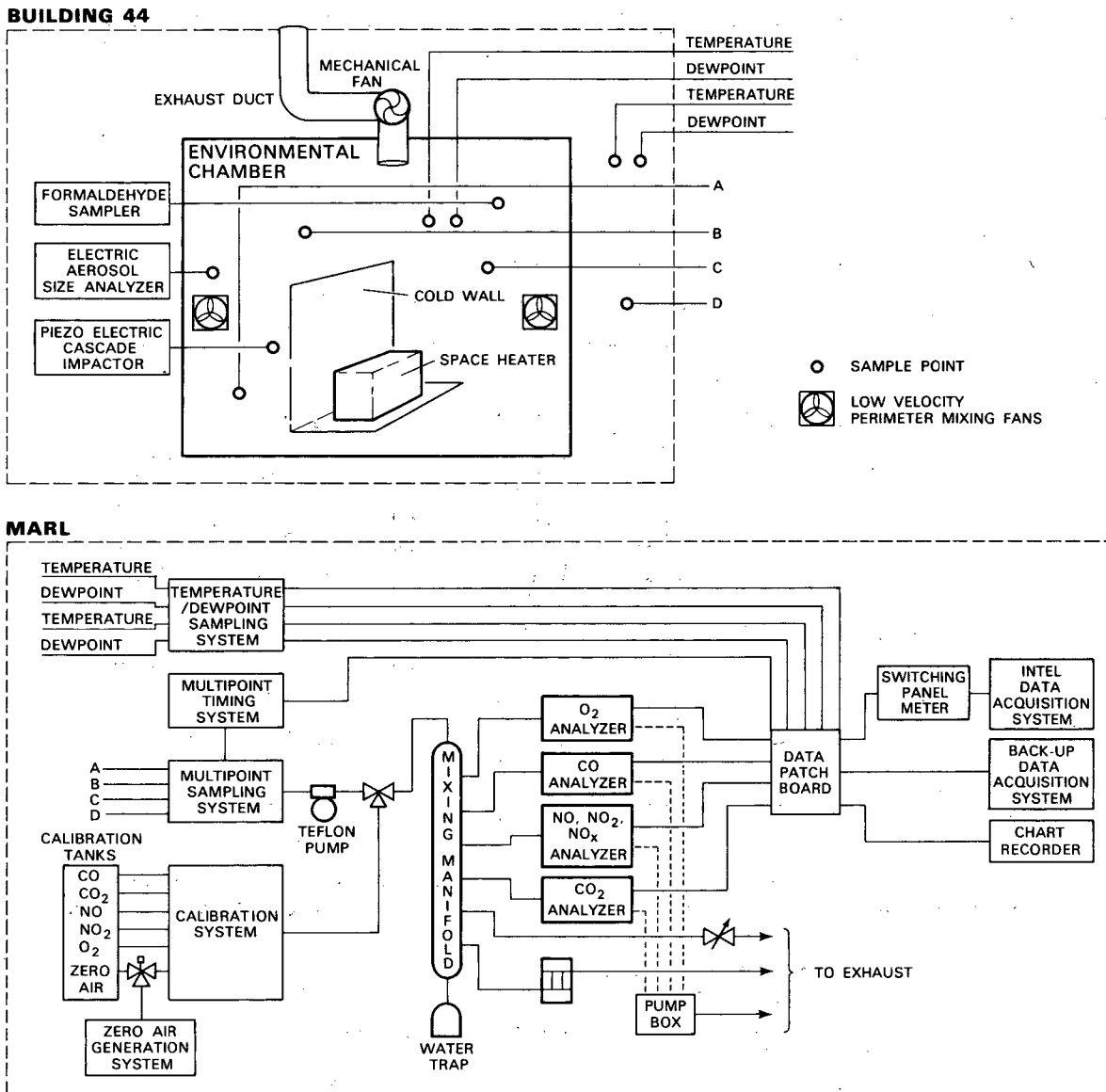

XBL 8110-1378A

Figure 1. Schematic diagram of Lawrence Berkeley Laboratory's Environmental Chamber and Mobile Atmospheric Research Laboratory (MARL).

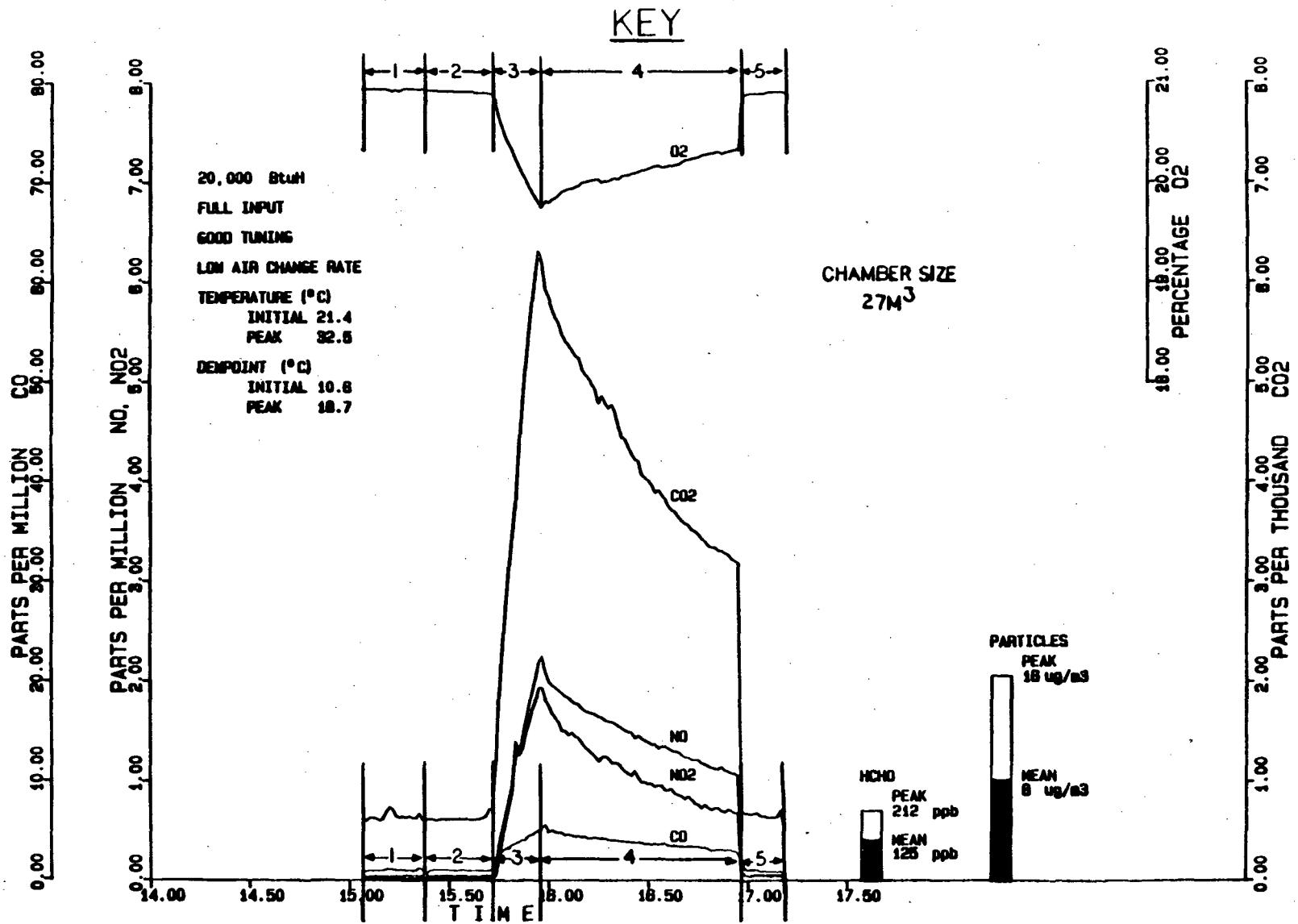

- Region 1: Sampling air external to the chamber (background).
- Region 2: Sampling air in chamber prior to ignition of UVGSH.
- Region 3: Sampling air in chamber while UVGSH is operating.
- Region 4: Sampling air in chamber with UVGSH off (decay).
- Region 5: Sampling air external to chamber (background check).

For formaldehyde and particles, peak is peak chamber concentration minus background ; the mean is the average over the decay portion of the data minus background .

Figure 2. Key illustrating different regions of concentration profiles as delineated by sampling.

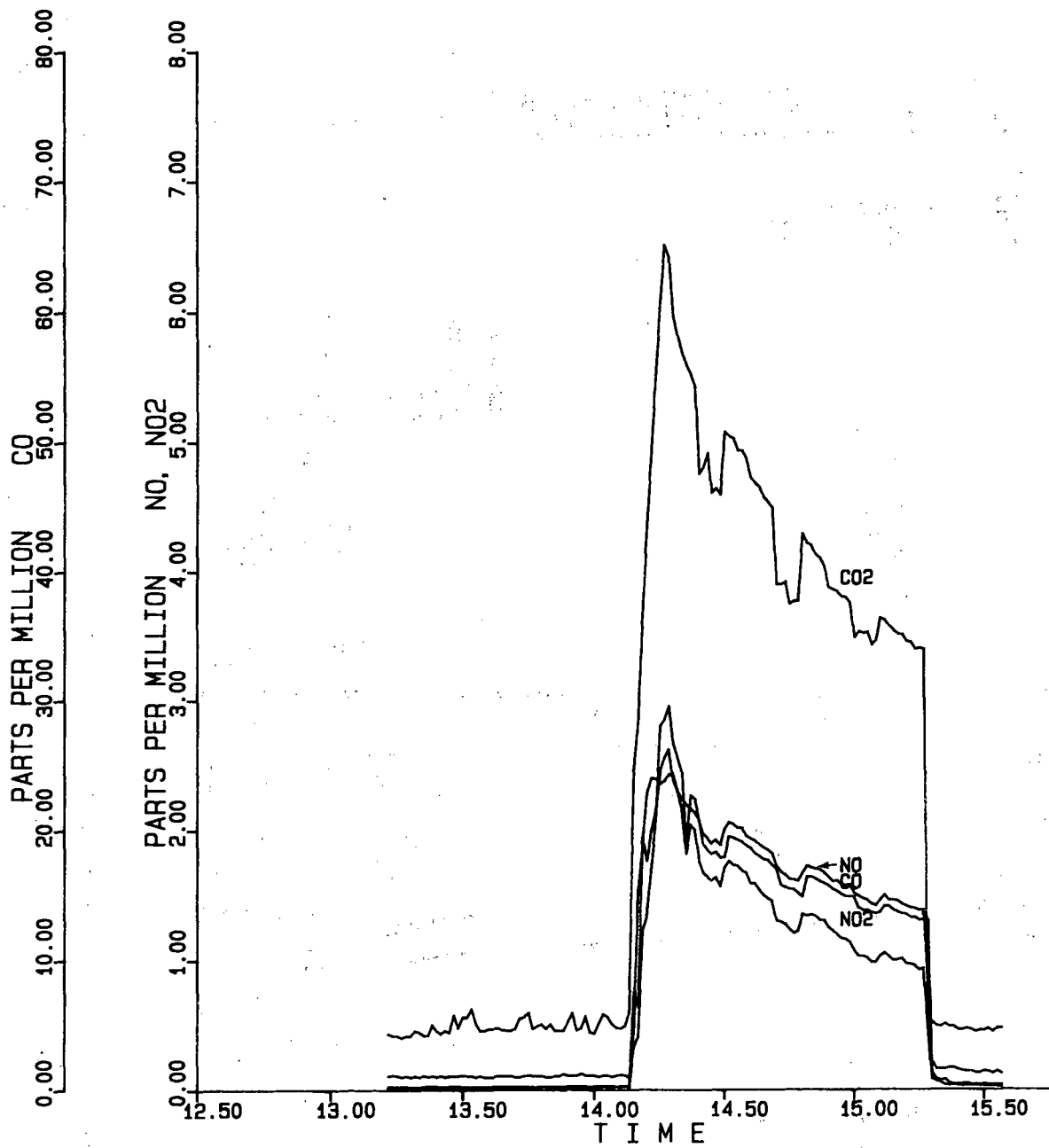

XBL 824-479

Figure 3. Mixing Test 1. Pollutant concentration profiles produced by the operation of an unvented gas-fired space heater in a 27-m³ chamber where four mixing fans operated a low speed. The effect in the decay region of the concentration profile of switching among three separated sampling probes is evident. Mixing is poor.

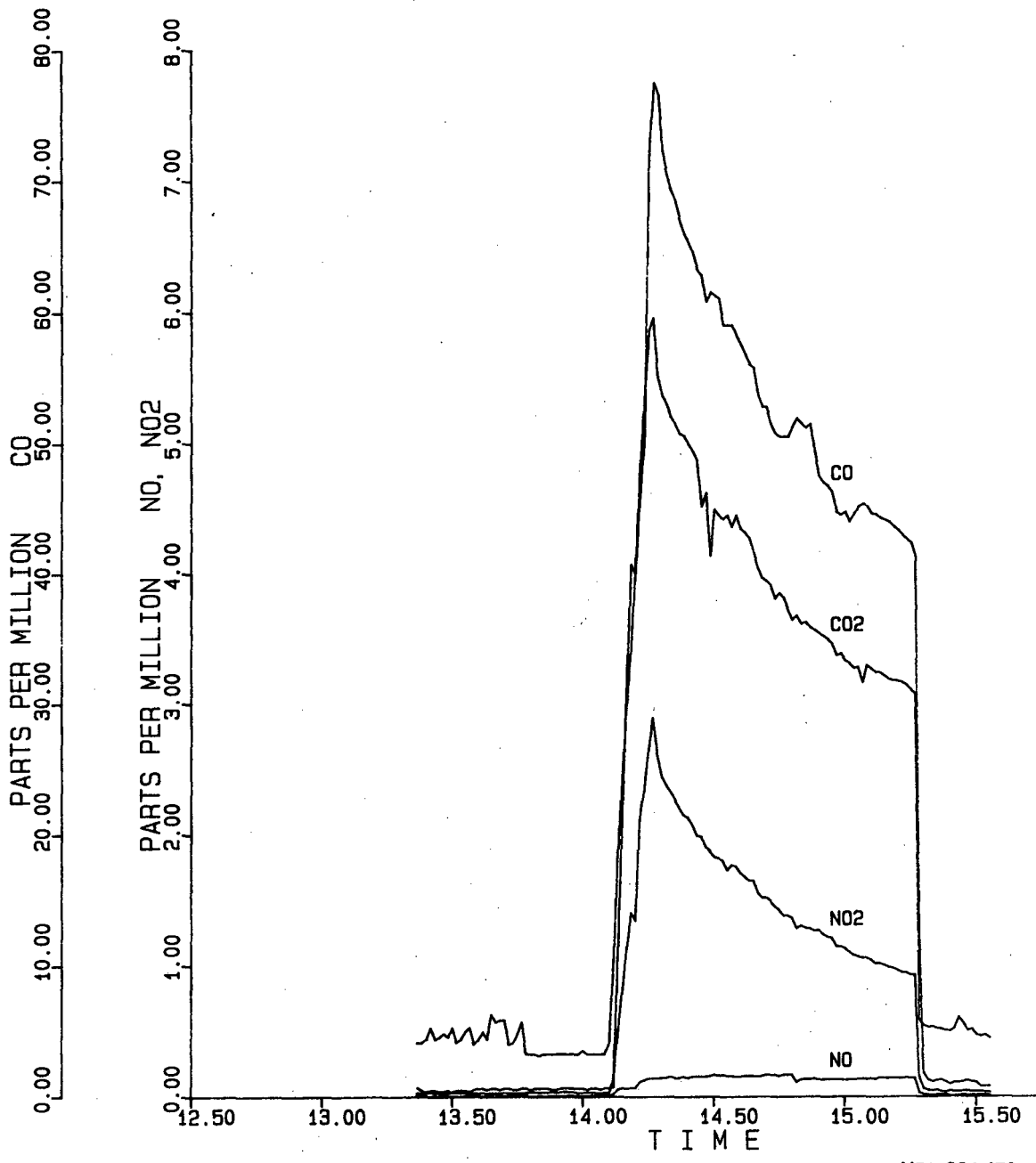

Figure 4. Mixing Test 2. Pollutant concentration profiles produced by the operation of an unvented gas-fired space heater in a 27-m³ chamber where six mixing fans operated at low speed. The effect in the decay region of the concentration profile of switching among three separated sampling probes is less evident. Mixing is improved.

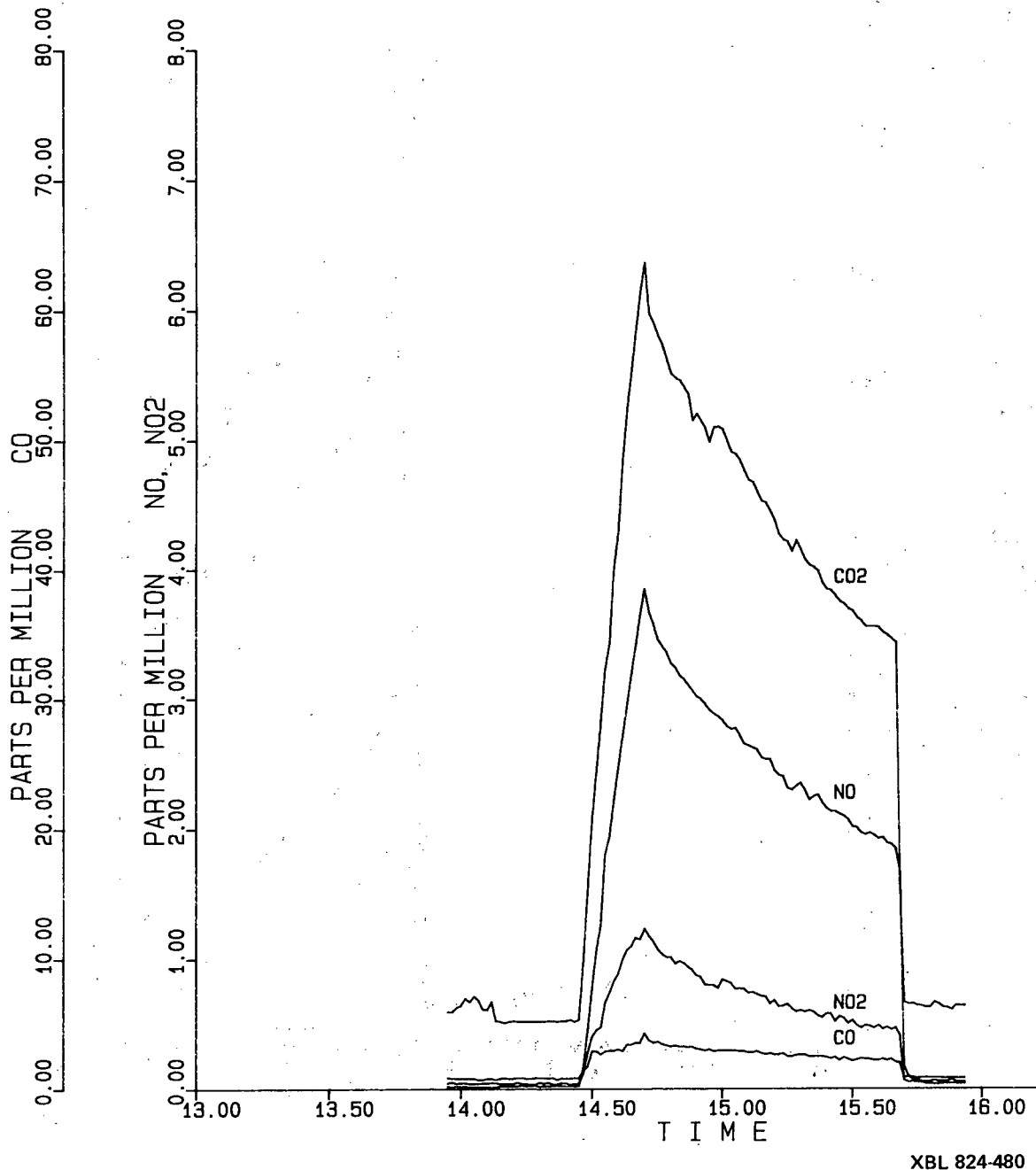
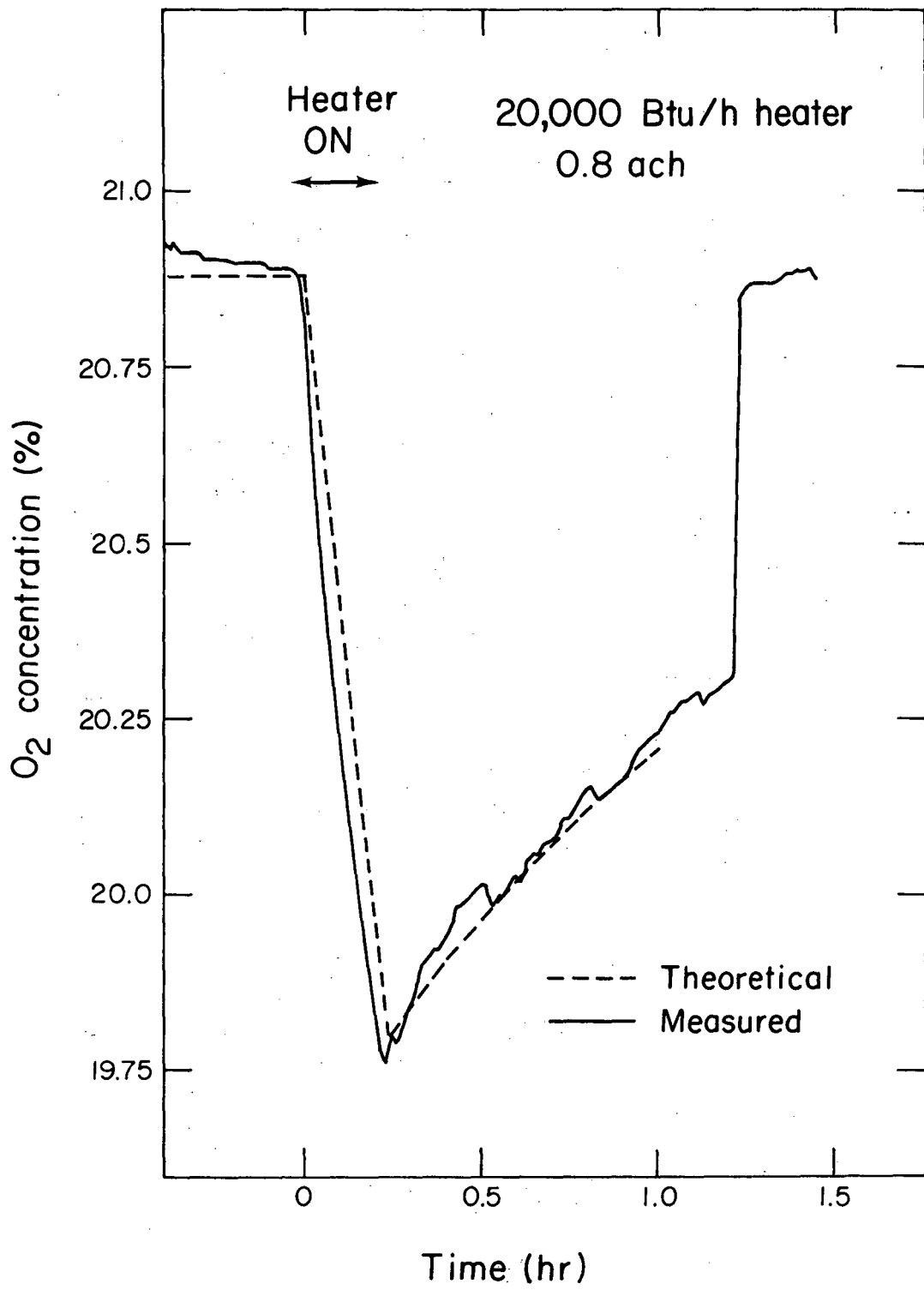
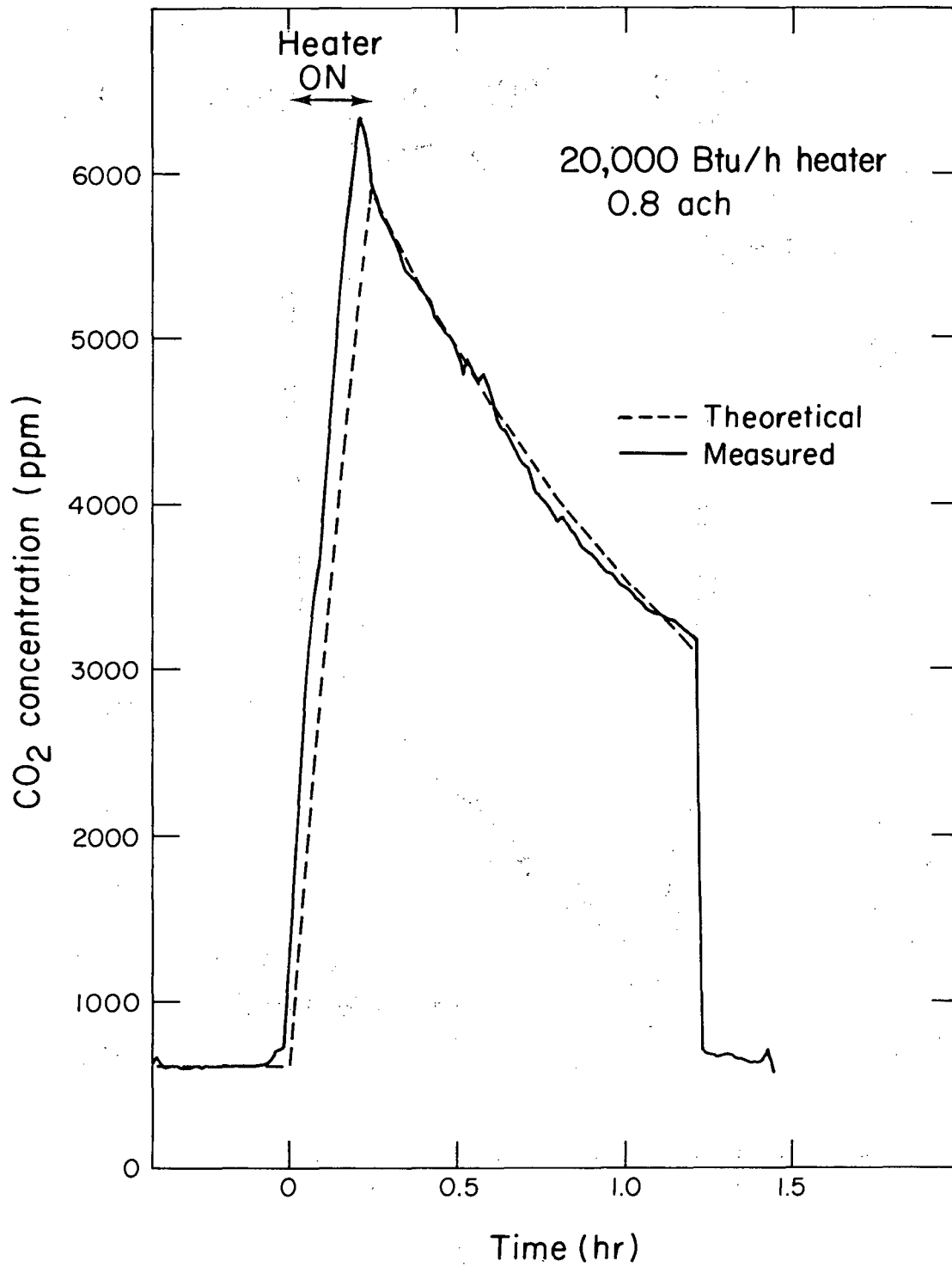

Figure 5. Mixing Test 3. Pollutant concentration profiles produced by the operation of an unvented gas-fired space heater in a 27-m³ chamber where six mixing fans operated at high speed. The effect in the decay region of the concentration profile of switching among three separated sampling probes is not evident. Mixing is good.



XBL 824-424

Figure 6. Calculated and measured O₂ concentration profiles produced by a 20,000 Btu/h unvented gas-fired space heater in a 27-m³ chamber.



XBL 824-428

Figure 7. Calculated and measured CO₂ concentration profiles produced by a 20,000 Btu/h unvented gas-fired space heater in a 27-m³ chamber.

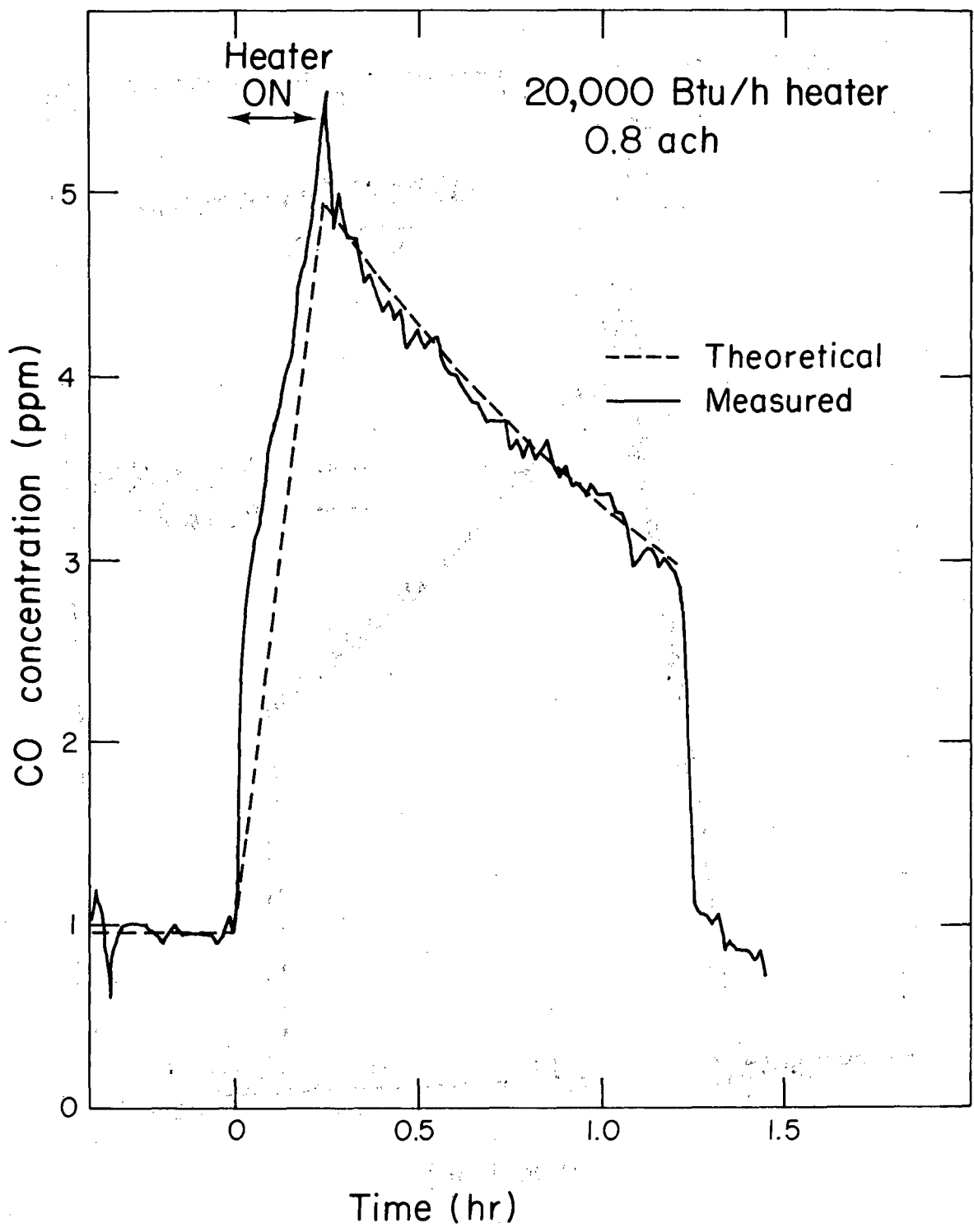

XBL 824-427

Figure 8. Calculated and measured CO concentration profiles produced by a 20,000 Btu/h unvented gas-fired space heater in a 27-m chamber.

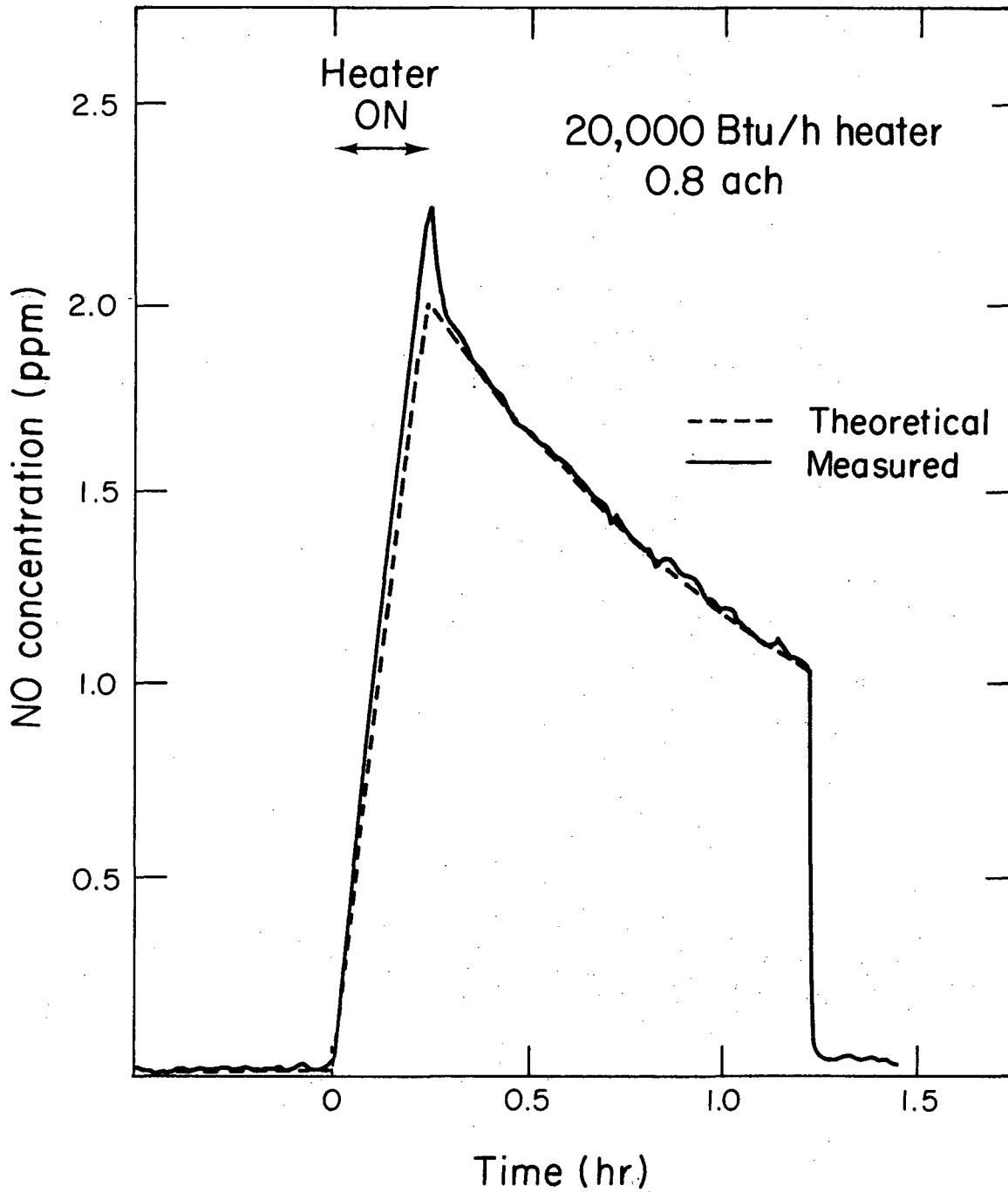

XBL 824-423

Figure 9. Calculated and measured NO concentration profiles produced by a 20,000 Btu/h unvented gas-fired space heater in a 27-m³ chamber.

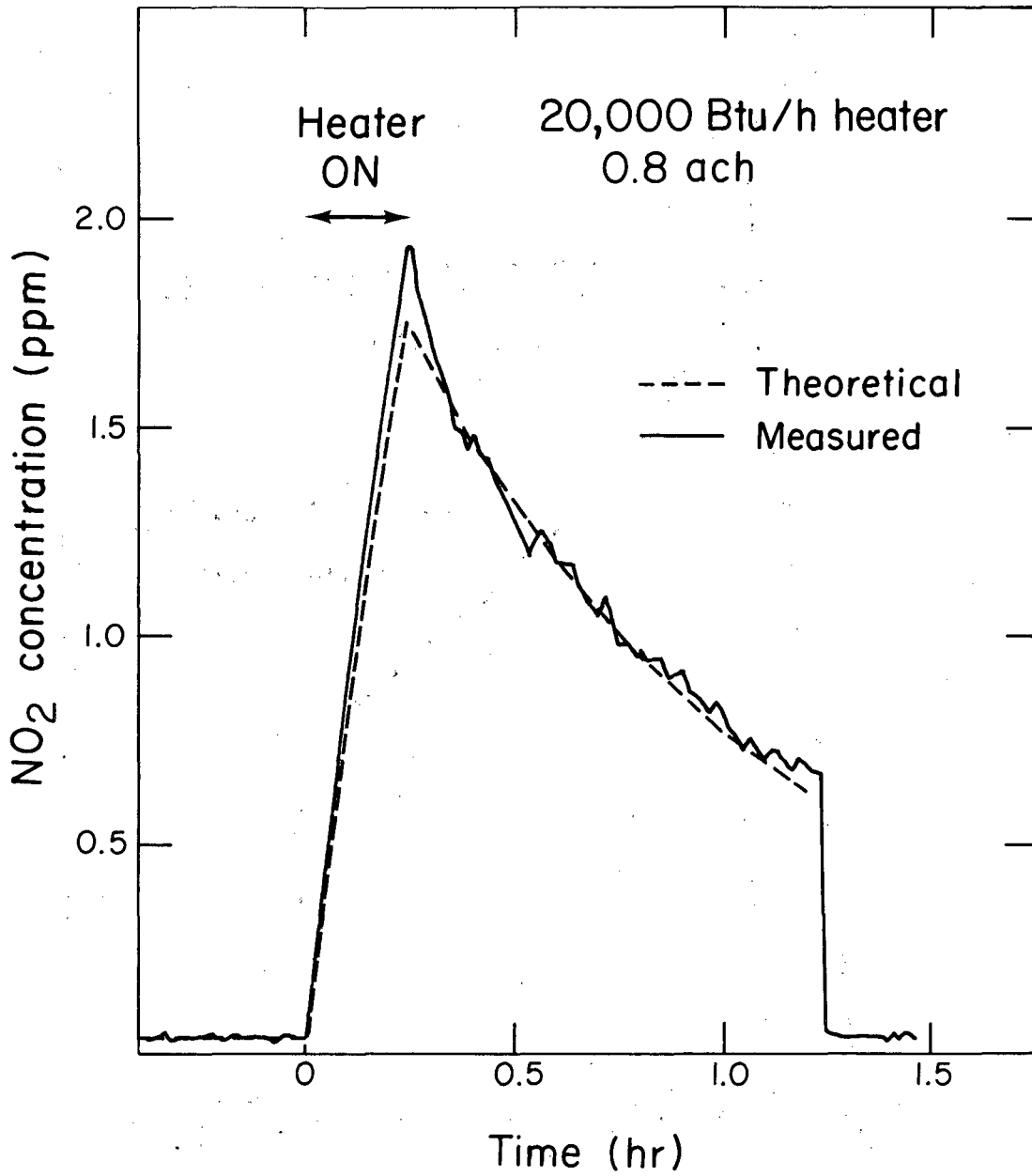

XBL 824-425

Figure 10. Calculated and measured NO₂ concentration profiles produced₃ by a 20,000 Btu/h unvented₂ gas-fired space heater in a 27-m³ chamber.

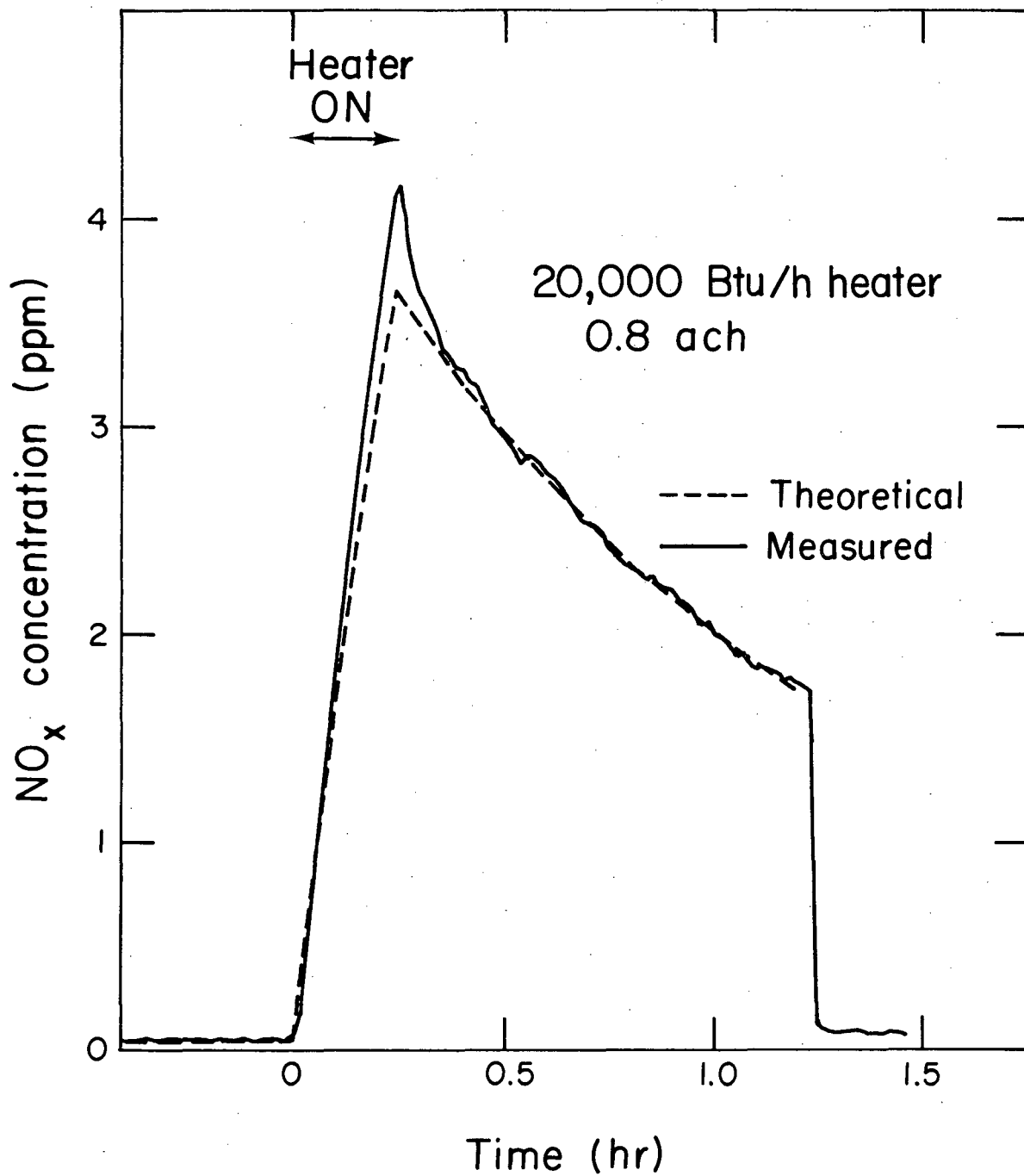

XBL 824-426

Figure 11. Calculated and measured NO_x concentration profiles produced by a 20,000 Btu/h unvented^x gas-fired space heater in a 27-m³ chamber.

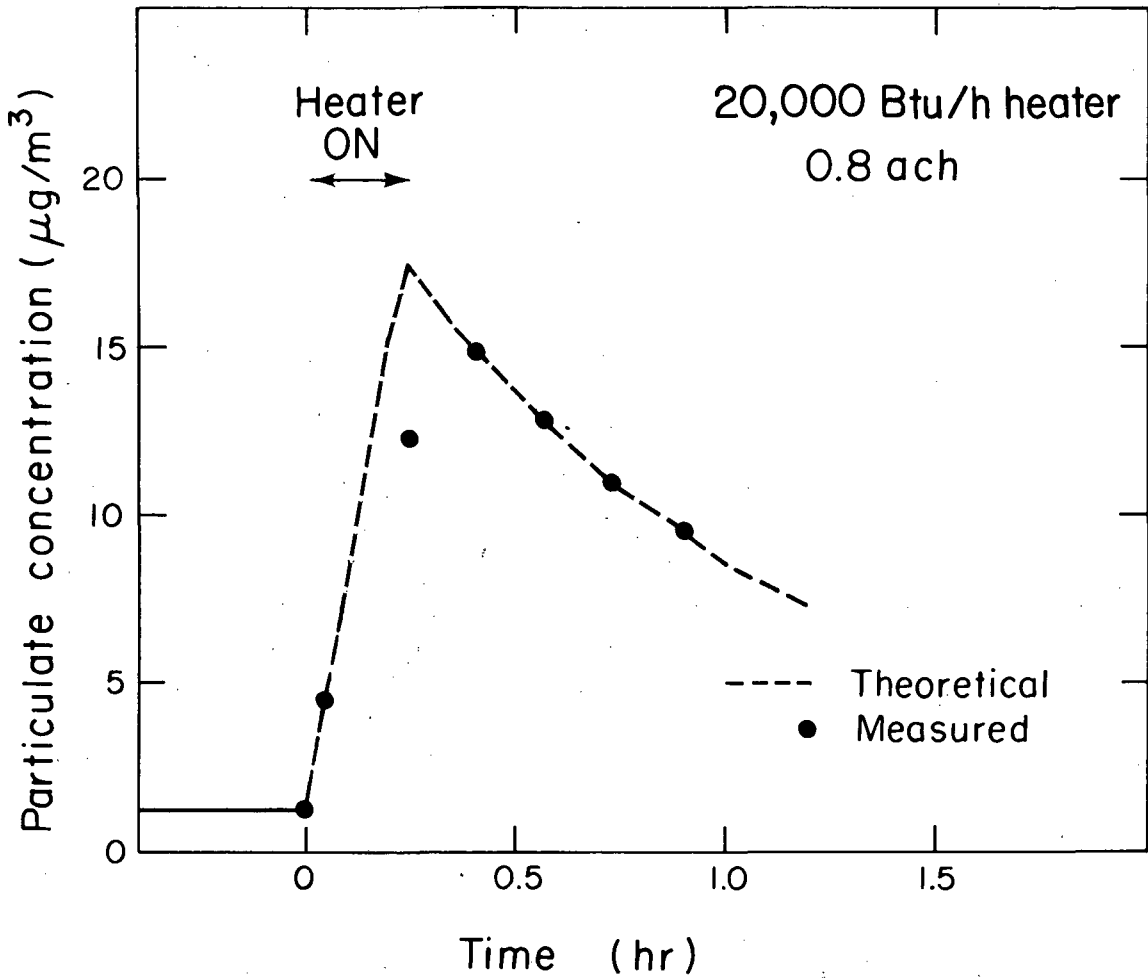

XBL 824-422

Figure 12. Calculated and measured particulate concentration profiles produced by a 20,000 Btu/h unvented gas-fired space heater in a 27-m³ chamber.

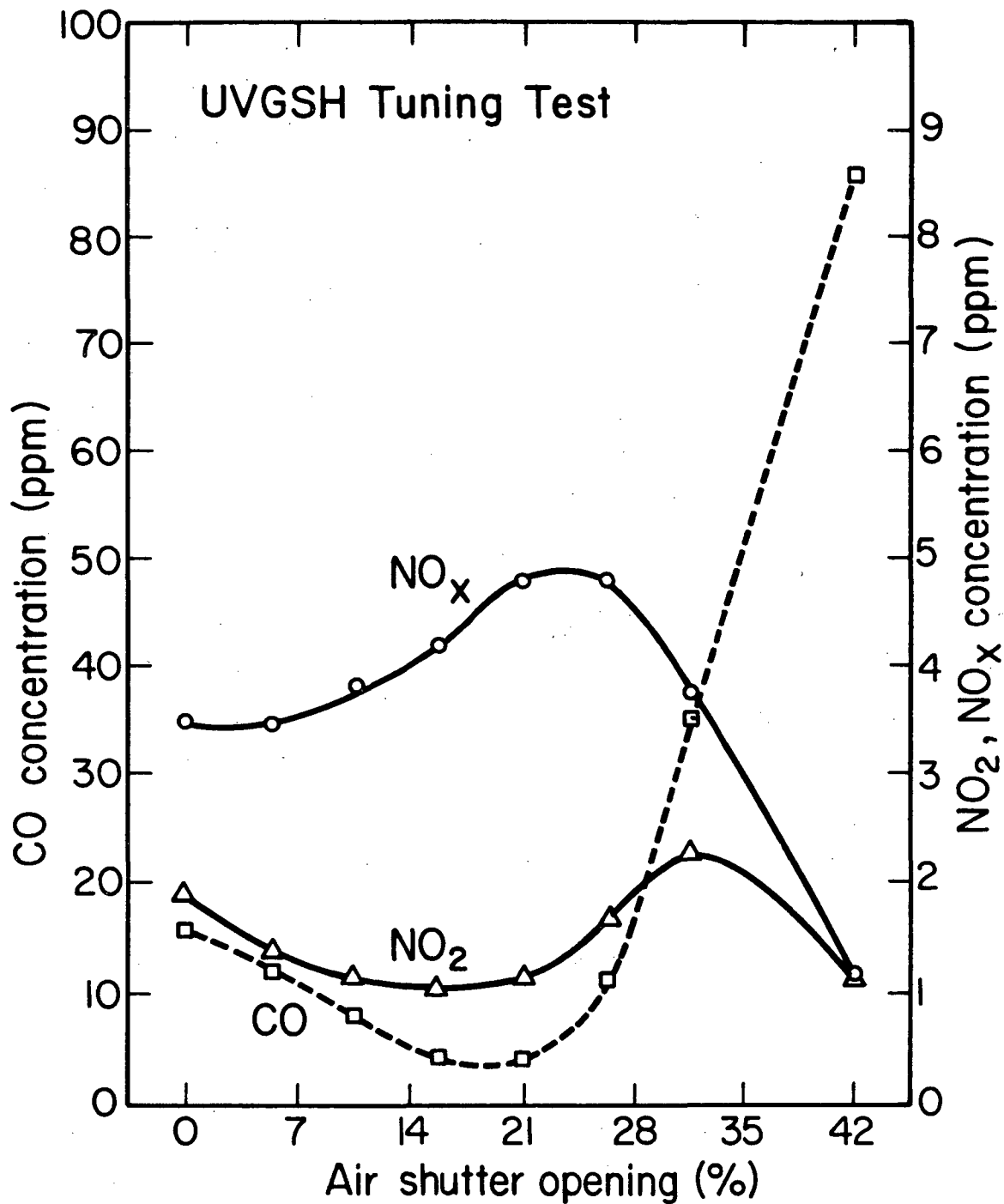

XBL 8210-1303

Figure 13 Peak CO, NO₂, and NO_x concentrations versus the air-shutter opening for a 31,700 kJ/h (30,000 Btu/h) unvented gas-fired space heater after combusting 5 ft³ of natural gas in a 27-m³ environmental chamber with a ventilation rate of approximately 0.4 ach.

Appendix

Test No.

Notes on Tests

-
- 1 Combusted 7.3 ft³ natural gas instead of 5 ft³.
 - 2 Three sampling probes were switched alternately every six minutes after the heater was shut off; perimeter mixing fans at low speed.
 - 3 Same as No. 2 but speed of mixing fans increased.
 - 4 Same as No. 3 but added one additional mixing fan and further increased speed of all mixing fans.
 - 5 Peak and mean value of particles are the same due to rounding of low values.
 - 10 Peak and mean value of particles are the same due to rounding of low values.
 - 13 Combusted 10.0 ft³ natural gas (double the normal amount) as a check of the model and protocol. Data missing from 12.4 to 13.1, CO₂ peak 11,100 ppm.
 - 14 Data missing from 17.7 to 18.1.
 - 18 Peak and mean value of particles are the same due to rounding of low values.
 - 29 Failure of data logger.
 - 34 Failure of data logger.
 - 37 CO peak 99.3 ppm.
 - 38 Formaldehyde histogram off scale CO peak 102.9 ppm.
 - 39 Peak and mean value of particles are the same due to rounding of low values.
 - 40 Data missing from 16.7 to 17.0.
 - 44 Data missing from 13.5 to 14.1.
 - 45 Data missing from 12.8 to 13.2.
 - 47 Peak and mean value of particles are the same due to rounding of low values.

Peak concentrations of gases.^a

Test No.	CO (ppm)	CO ₂ (ppm)	N(NO _x) (ppm)	O ₂ (%)
1	34.5	7000	6.5	18.9
2	20.7	5370	4.2	20.0
3	68.0	5120	2.5	20.0
4	3.5	6000	4.6	19.8
5	4.3	5640	4.6	19.8
6	4.9	5900	3.7	19.8
7	2.3	6350	4.2	19.9
8	3.7	6410	4.0	19.9
9	1.8	6710	4.4	19.9
10	69.5	6060	33.0	19.9
11	11.6	6450	5.3	19.7
12	2.5	6250	4.0	19.7
13	2.8	10410	7.3	19.0
14	28.8	6070	4.2	19.9
15	15.0	7570	6.1	19.7
16	32.1	5370	3.0	20.0
17	10.3	5830	3.5	20.0
18	11.5	6350	5.0	19.8
19	14.8	5630	3.4	20.0
20	5.5	6160	4.9	19.8
21	4.7	5960	4.5	19.9
22	2.1	6920	4.0	19.7
23	45.7	5810	3.9	19.8
24	34.7	3870	2.8	20.2
25	33.8	3660	2.7	20.2
26	29.9	3550	2.4	20.2
27	4.1	4970	3.8	20.0
28	2.3	4960	3.7	20.1
30	2.1	6120	3.1	19.9
31	2.6	4960	2.4	20.1
32	2.1	5820	2.8	19.9
33	23.1	3160	1.4	20.2
35	6.9	6190	3.5	19.8
36	2.6	6240	4.4	19.8
37	97.5	4920	1.0	20.1
38	92.3	5270	1.2	20.0
39	28.5	6290	4.0	19.7
40	3.3	6290	4.0	19.6
41	1.8	5070	3.2	19.7
42	2.5	3390	1.7	20.4
43	14.7	5810	3.0	19.9
44	18.6	5490	2.8	20.0
45	9.5	2870	1.8	20.3
46	2.4	5920	2.5	20.0
47	3.4	5990	2.5	19.8
48	3.8	5850	3.2	20.0
49	3.1	6260	2.8	19.8
50	2.1	6510	3.7	19.6

^aCalculated by linear regression of data from pollutant decay.

Ancillary Test Data

Test	Heater	Gas	Gas	Δt (min:sec)	Gas Combusted	
		On (hr:min:sec)	Off (hr:min:sec)		ft ³	kJ
1	30A	14:52:00	15:07:00	15:00	7.34	8140
2	30A	14:07:20	14:16:38	9:18	5.03	5560
3	30A	14:06:08	14:15:20	9:12	4.98	5520
4	20A	14:27:00	14:41:35	14:35	5.02	5560
5	20A	11:50:00	12:04:00	14:00	5.02	5570
6	20C	15:43:35	15:57:37	14:02	5.00	5540
7	30C	13:07:40	13:18:08	10:28	5.02	5570
8	40C	11:46:35	11:54:10	7:35	5.01	5540
9	40C	15:03:57	15:11:50	7:53	4.99	5530
10	30A	13:42:40	13:52:40	10:00	5.03	5570
11	20A	15:51:48	16:07:20	15:32	5.02	5570
12	20C	11:01:40	11:17:03	15:23	5.02	5570
13	20C	12:58:49	13:29:12	30:23	10.20	11110
14	16B	17:02:54	17:21:34	18:40	5.01	5550
15	40B	13:29:20	13:38:22	9:02	5.01	6660
16	12A	12:58:48	13:31:00	32:12	4.99	5530
17	12A	12:55:00	13:28:05	33:05	5.01	5560
18	40B	15:12:47	15:20:12	7:25	5.02	5570
19	12A	14:40:49	15:13:45	32:56	5.03	5570
20	30A	12:57:07	13:06:35	9:28	5.02	5540
21	30A	12:39:30	12:48:52	9:22	5.03	5580
22	40C	16:00:38	16:08:33	7:55	5.02	5560
23	16B	14:31:04	14:49:55	18:51	5.00	5550
24	16B	14:57:36	15:17:13	20:37	5.02	5560
25	16B	14:29:32	14:49:18	19:46	5.02	5570
26	16B	13:15:09	13:34:26	19:17	4.92	5450
27	30A	16:07:45	16:17:18	9:33	5.02	5570
28	40C	13:10:20	13:18:08	7:48	5.03	5580
29	40C	12:05:25	12:12:57	7:32	5.00	5530
30	40C	14:23:34	14:36:00	12:26	5.03	5580
31	40C	14:14:19	14:28:16	13:57	4.99	5530
32	40C	13:11:43	13:24:58	13:15	5.02	5560
33	40C	11:47:50	12:08:57	21:07	5.01	5560
34	40C	15:01:29	15:08:56	7:37	5.02	5560
35	40C	12:37:00	12:44:41	7:41	5.01	5560
36	40C	15:47:00	15:54:35	7:35	4.99	5550
37	30A	10:57:40	11:07:30	9:50	5.01	5550
38	30A	14:28:50	14:38:40	9:45	5.02	5570
39	30A	10:54:28	11:04:24	9:56	5.02	5560
40	30A	15:41:42	16:00:16	18:34	5.01	5550
41	30A	13:11:11	13:26:35	15:14	5.01	5560
42	30A	11:24:26	11:51:10	26:44	5.09	5560
43	16B	15:44:15	16:19:10	34:55	5.02	5560
44	16B	11:59:50	12:36:18	36:28	5.01	5560
45	16B	11:13:28	11:46:15	32:47	5.01	5550
46	12A	11:06:32	11:57:55	51:23	5.01	5560
47	20C	12:12:30	12:42:23	29:53	5.01	5550
48	20A	11:55:20	12:25:40	30:20	4.91	5560
49	30C	15:24:40	15:48:50	24:10	5.02	5560
50	40B	15:04:25	15:19:05	14:40	5.14	5700

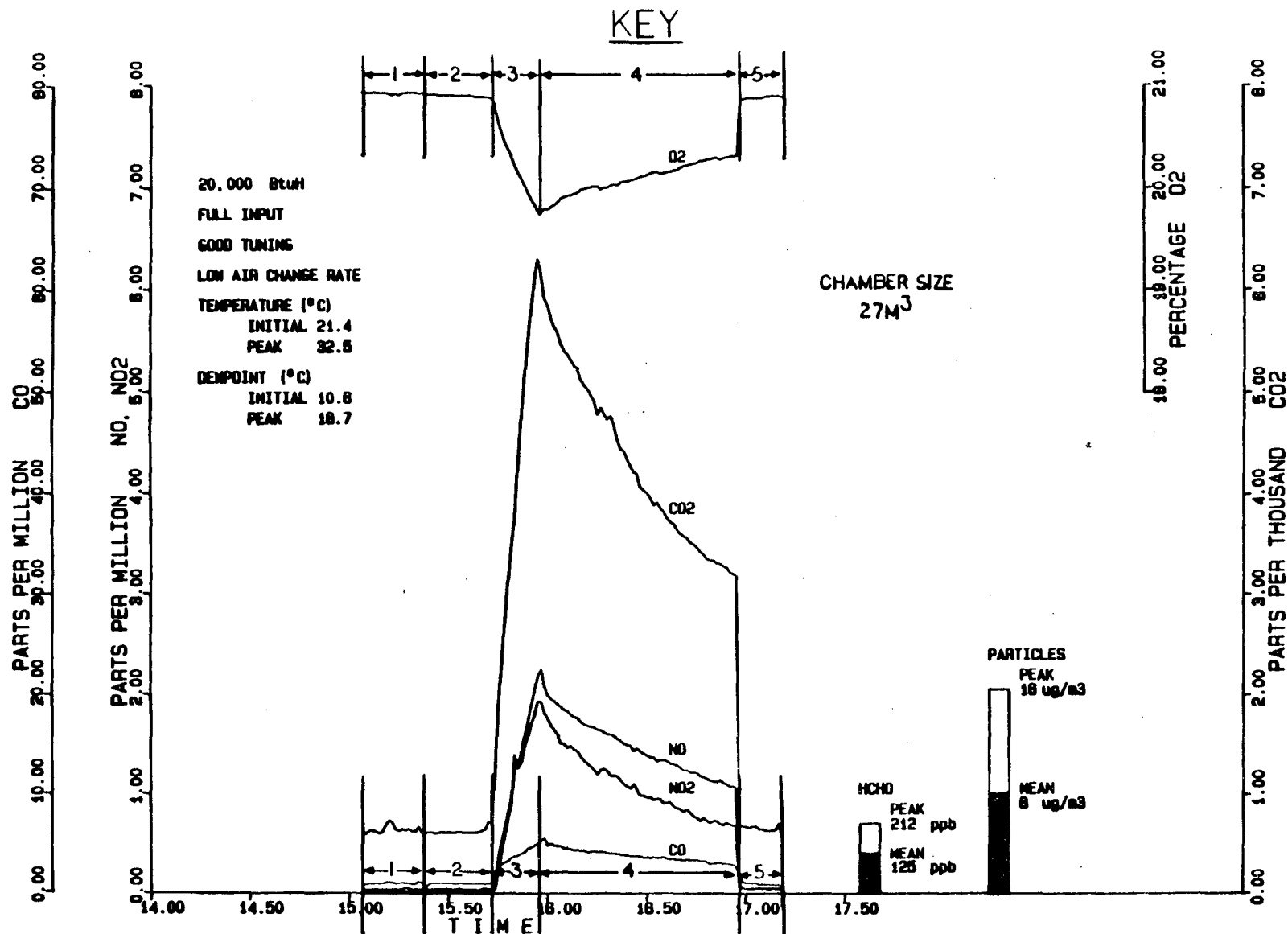

- Region 1: Sampling air external to the chamber (background).
- Region 2: Sampling air in chamber prior to ignition of UVGSH.
- Region 3: Sampling air in chamber while UVGSH is operating.
- Region 4: Sampling air in chamber with UVGSH off (decay).
- Region 5: Sampling air external to chamber (background check).

For formaldehyde and particles, peak is peak chamber concentration minus background ; the mean is the average over the decay portion of the data minus background .

-A7-

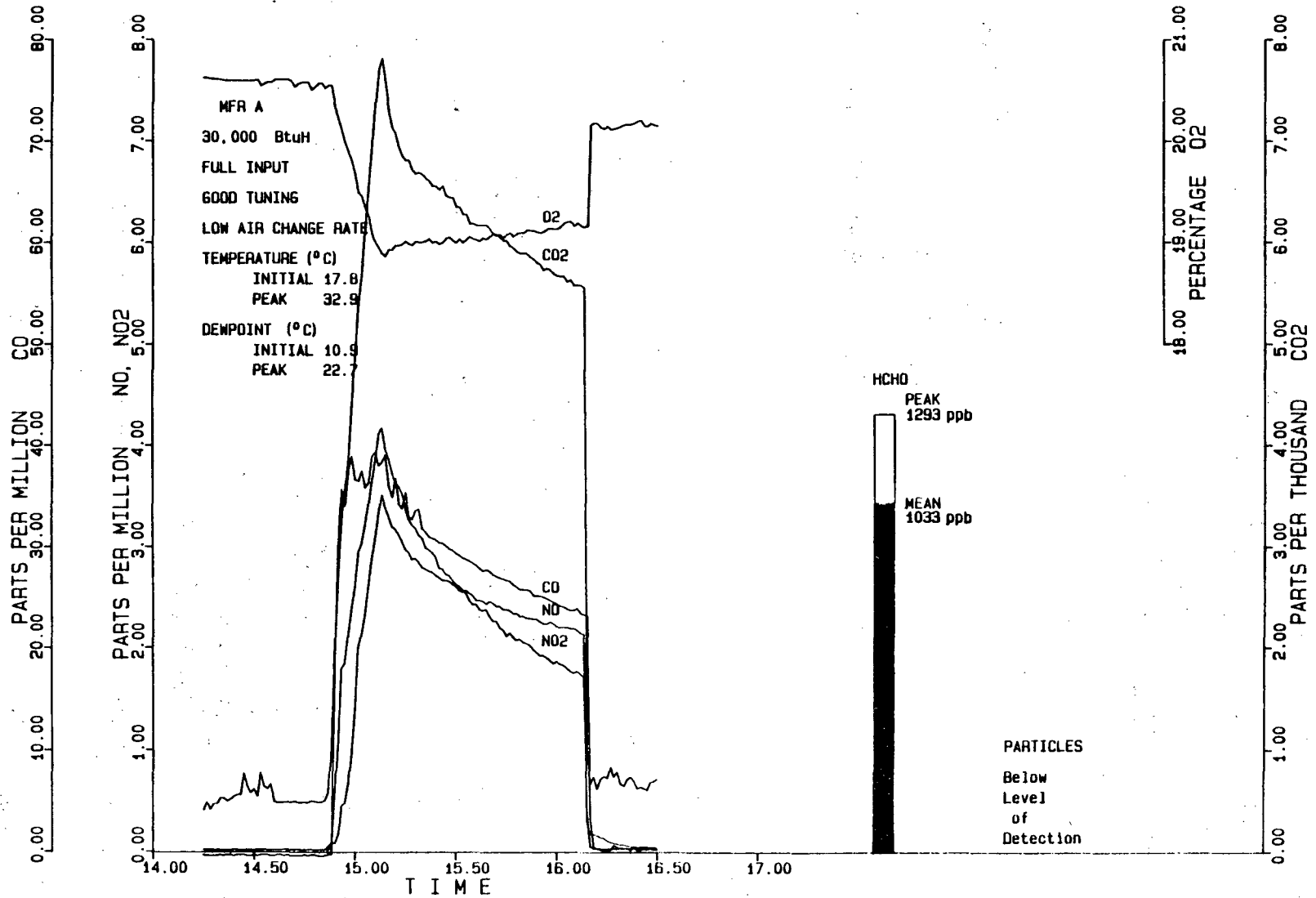

2

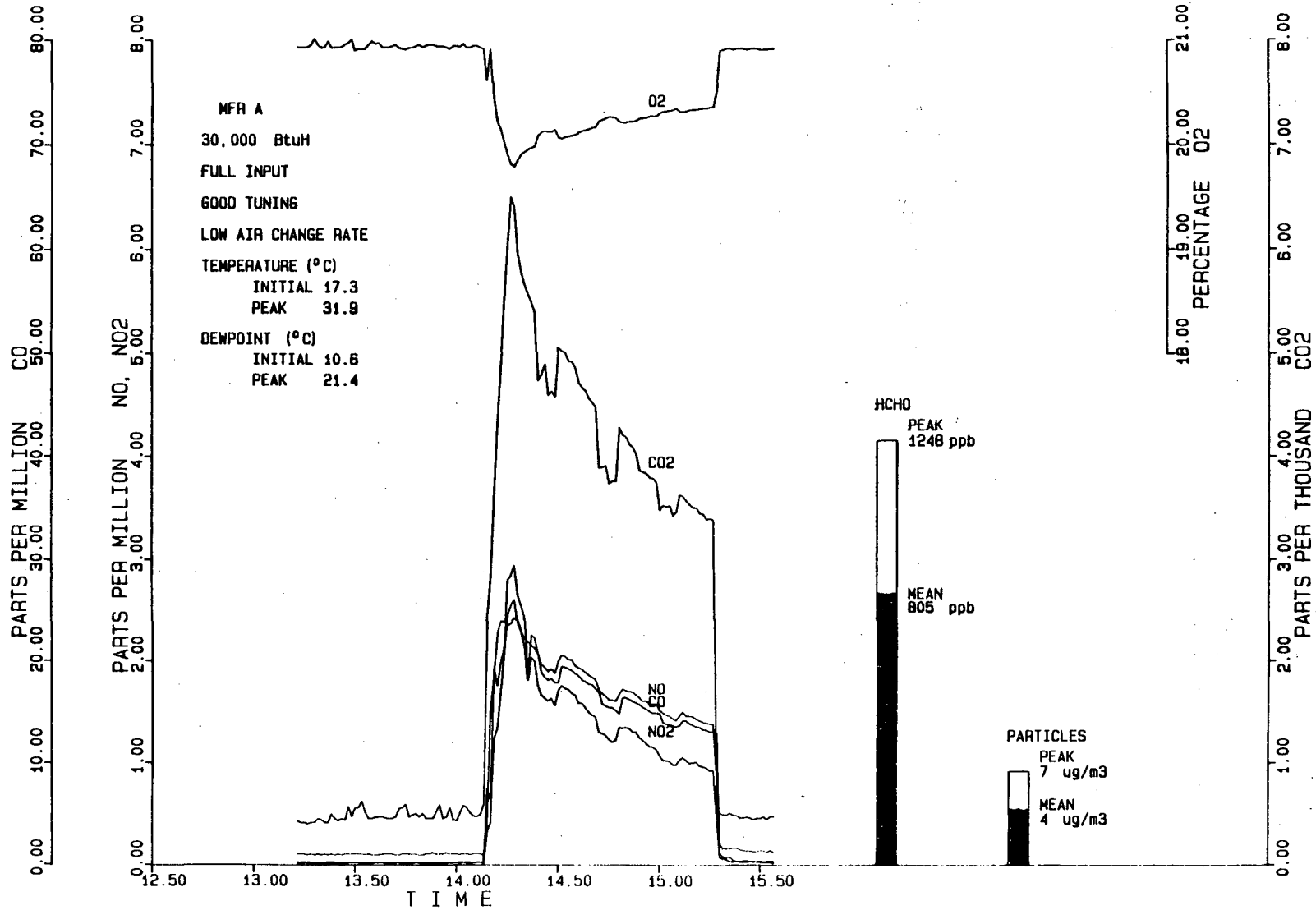

3

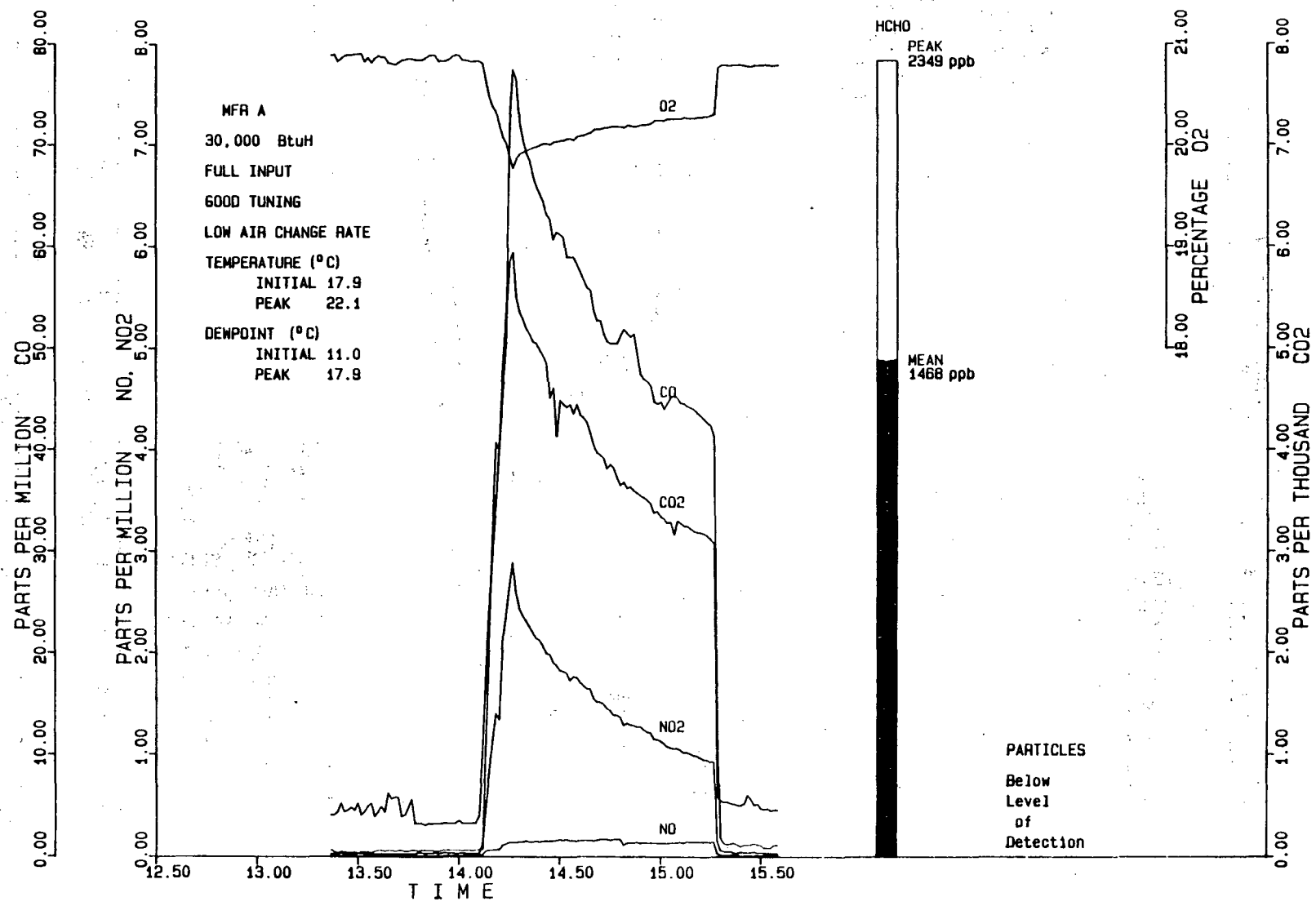

-A10-

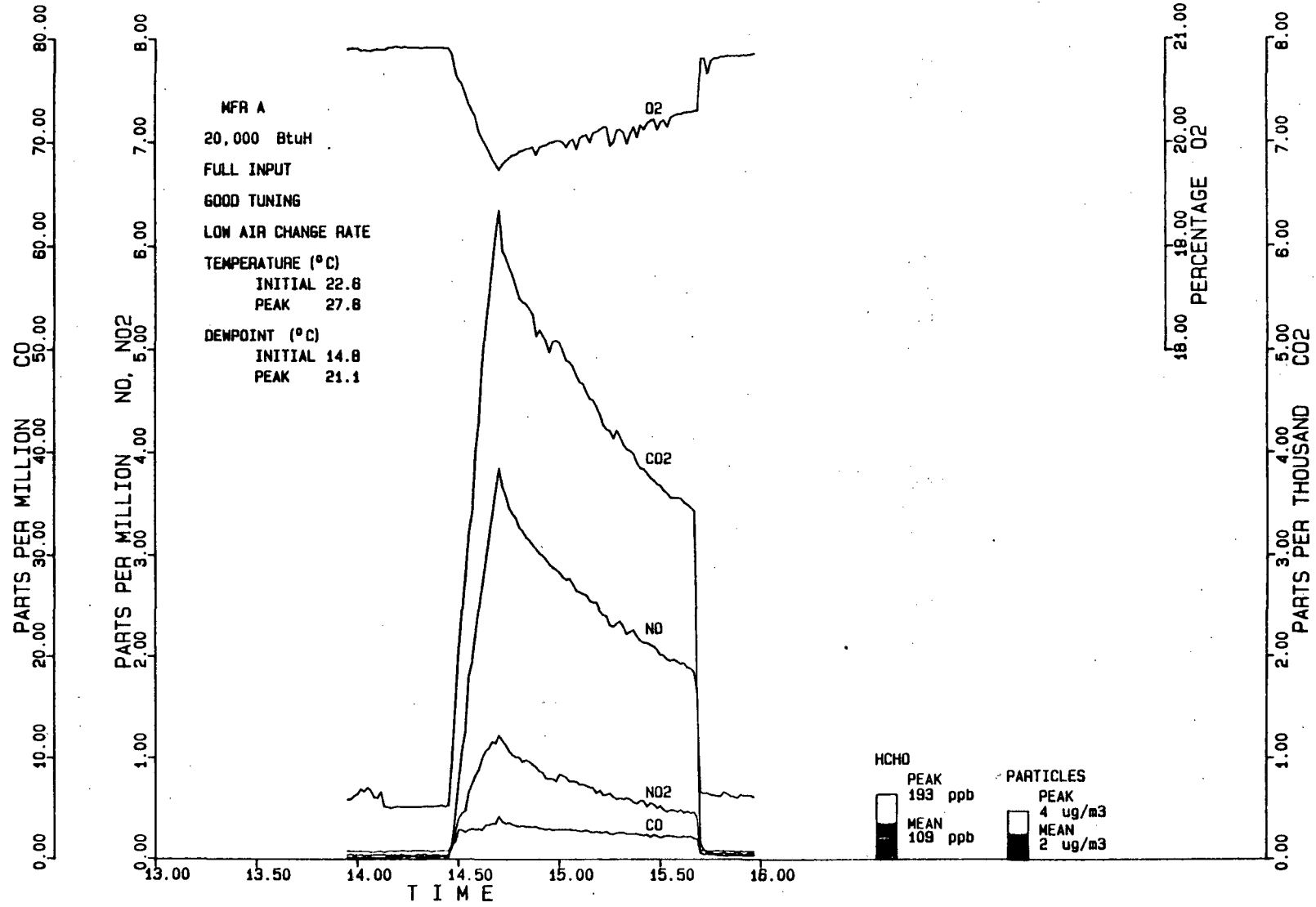

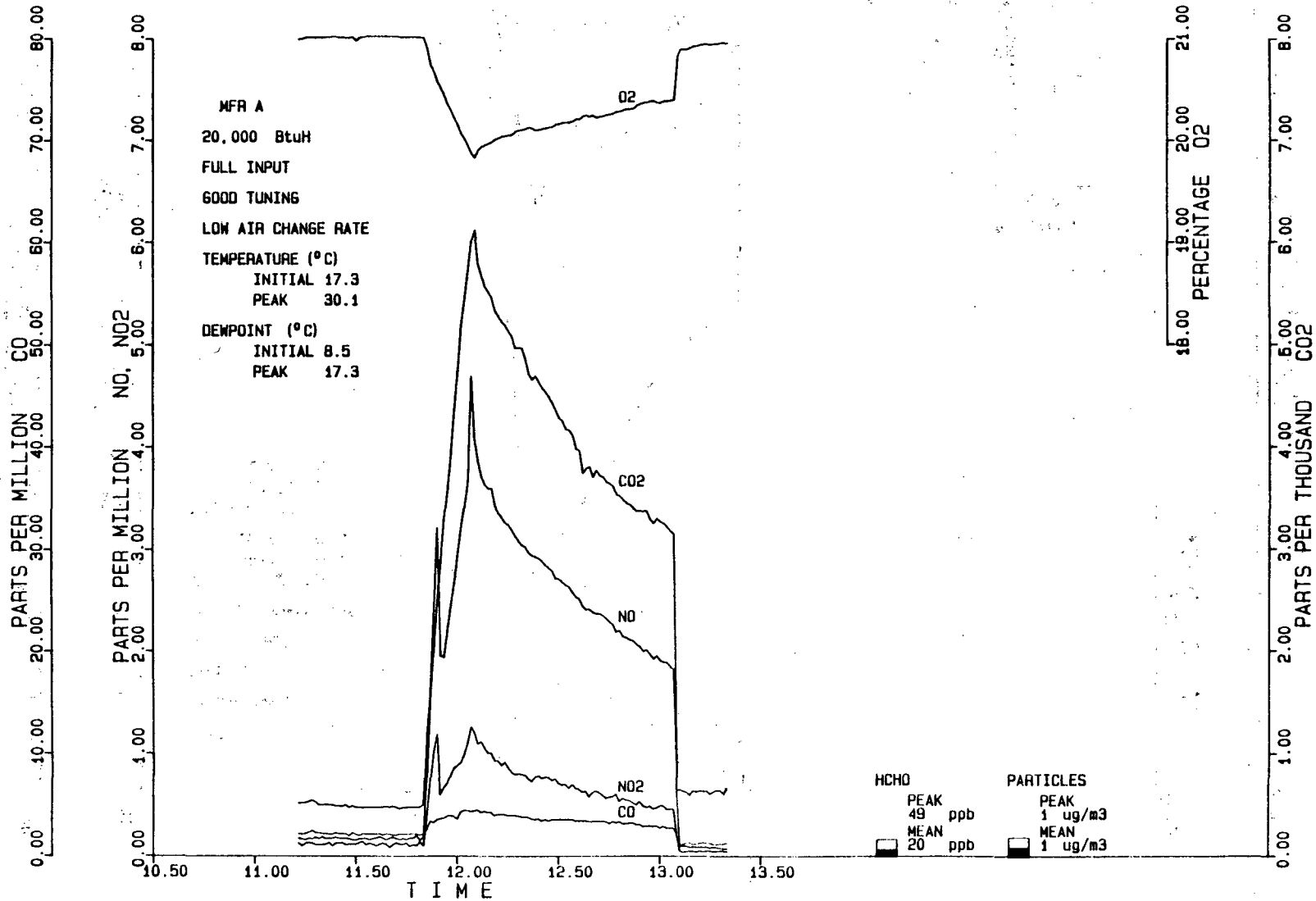

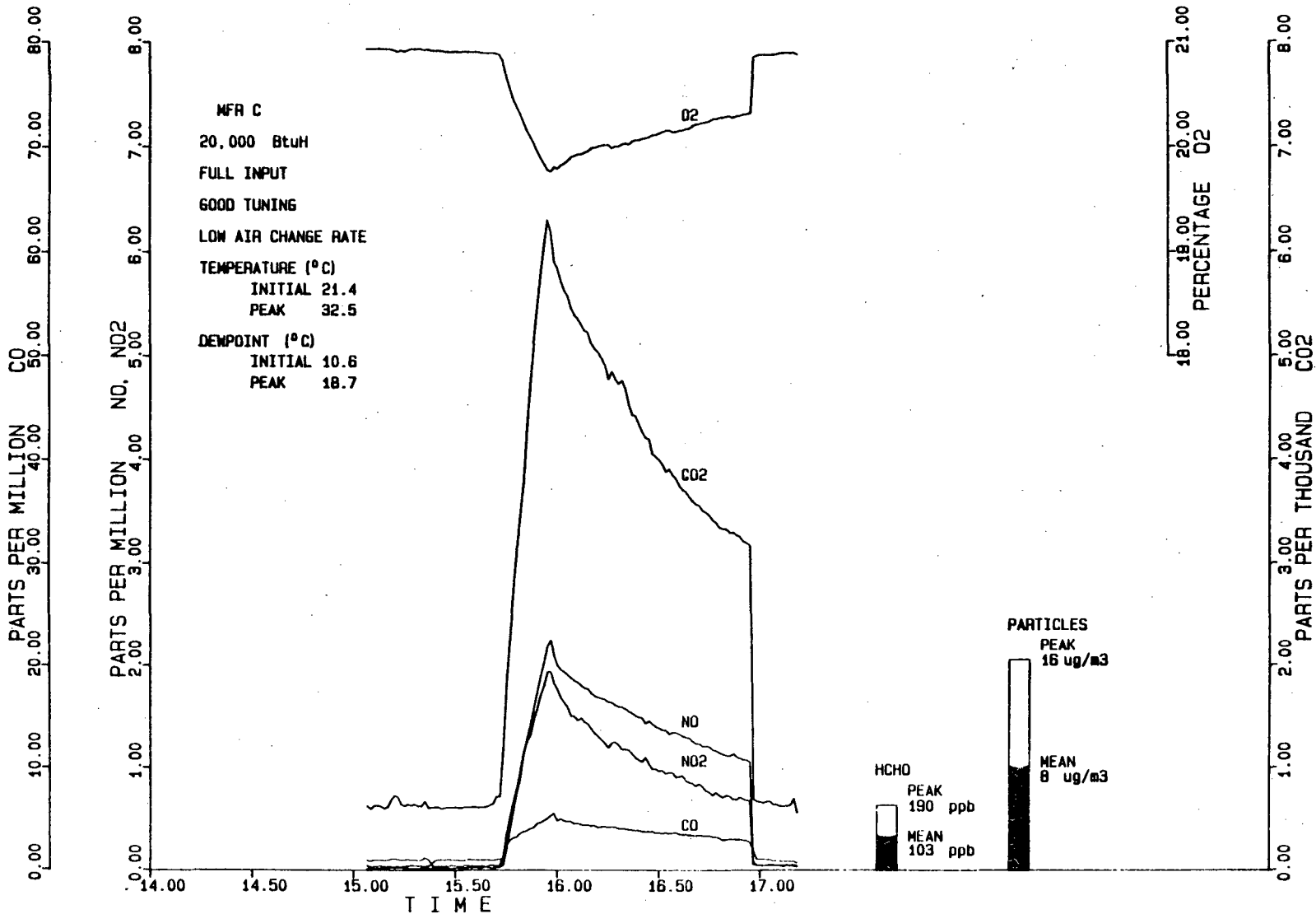

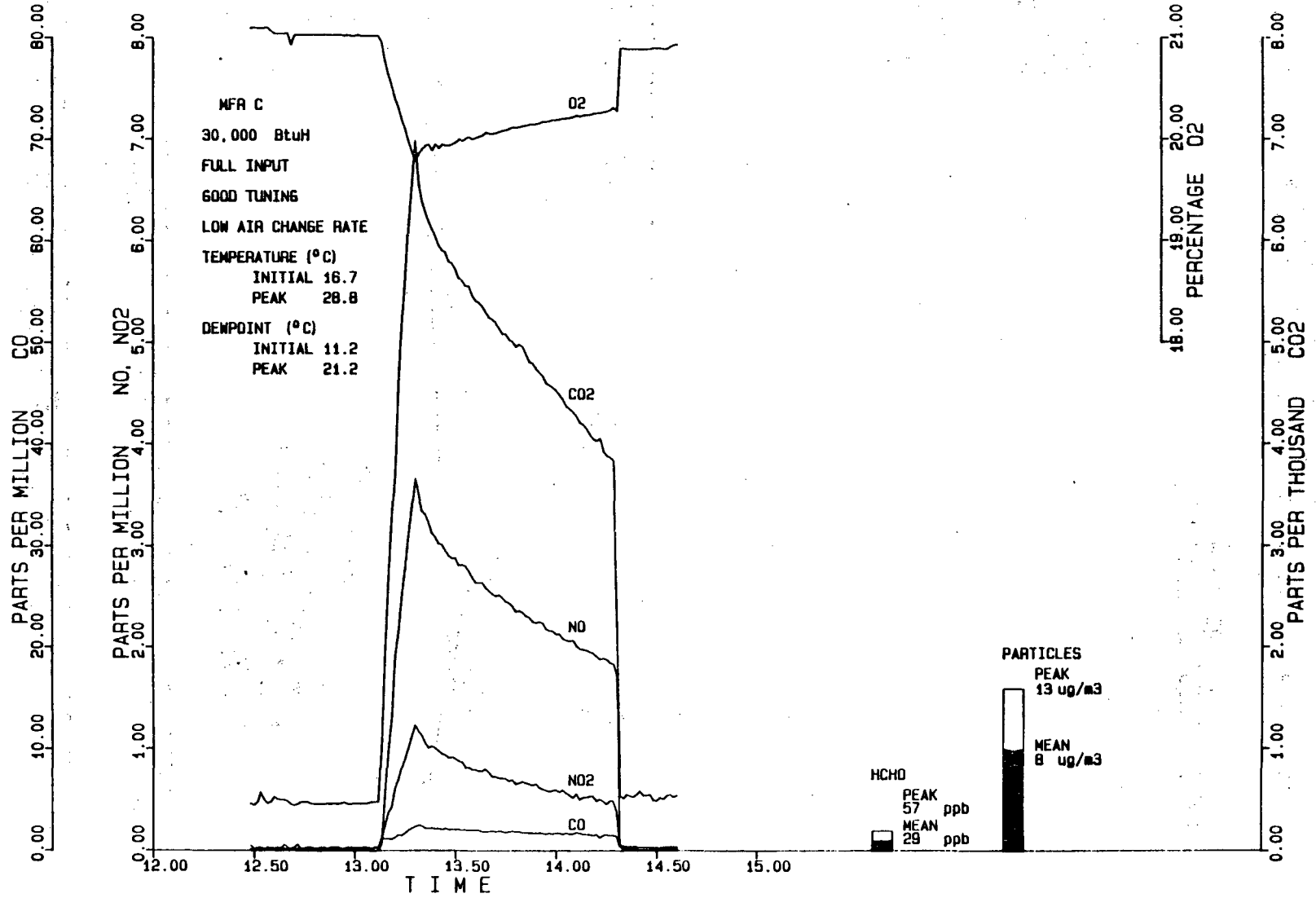

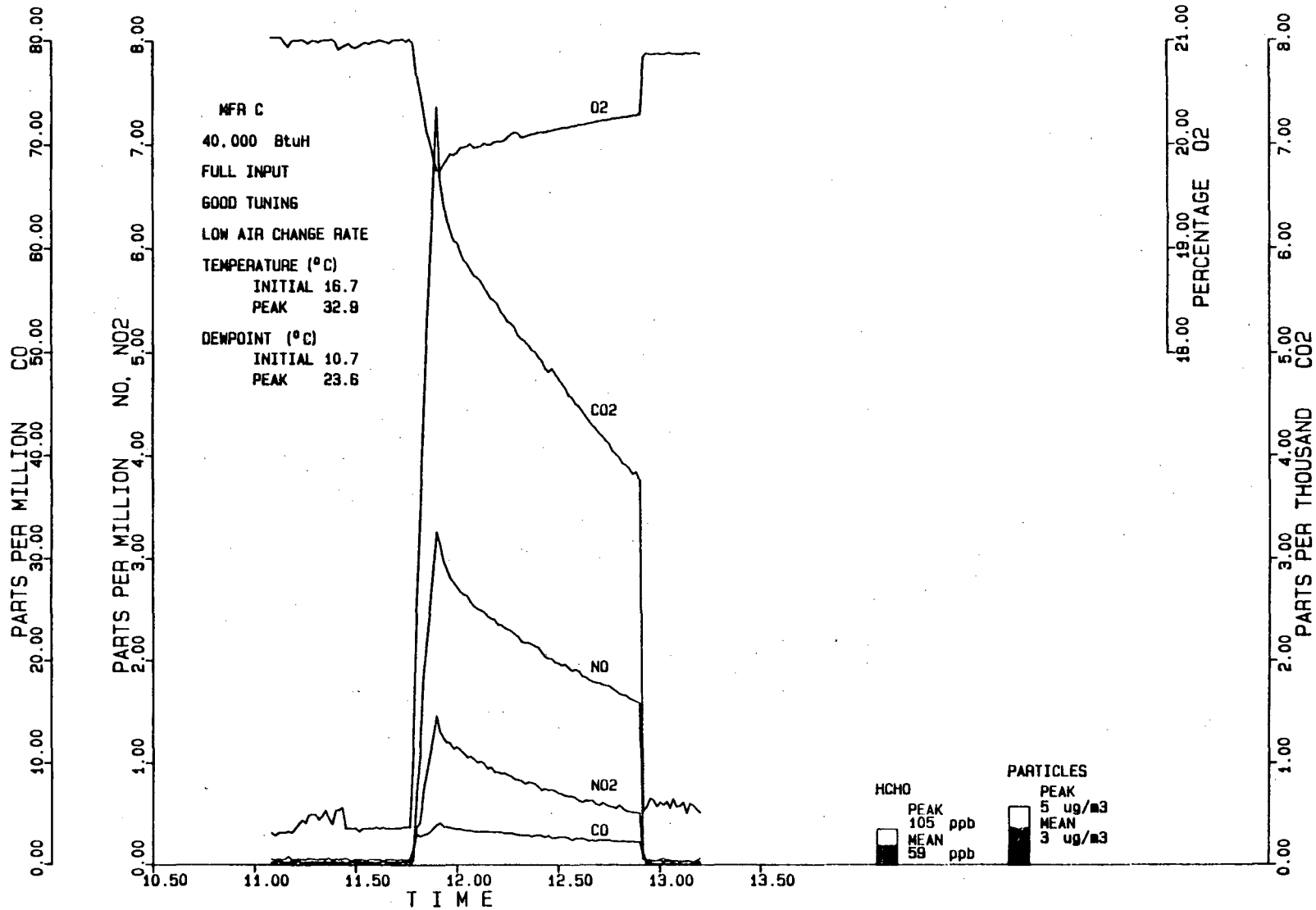

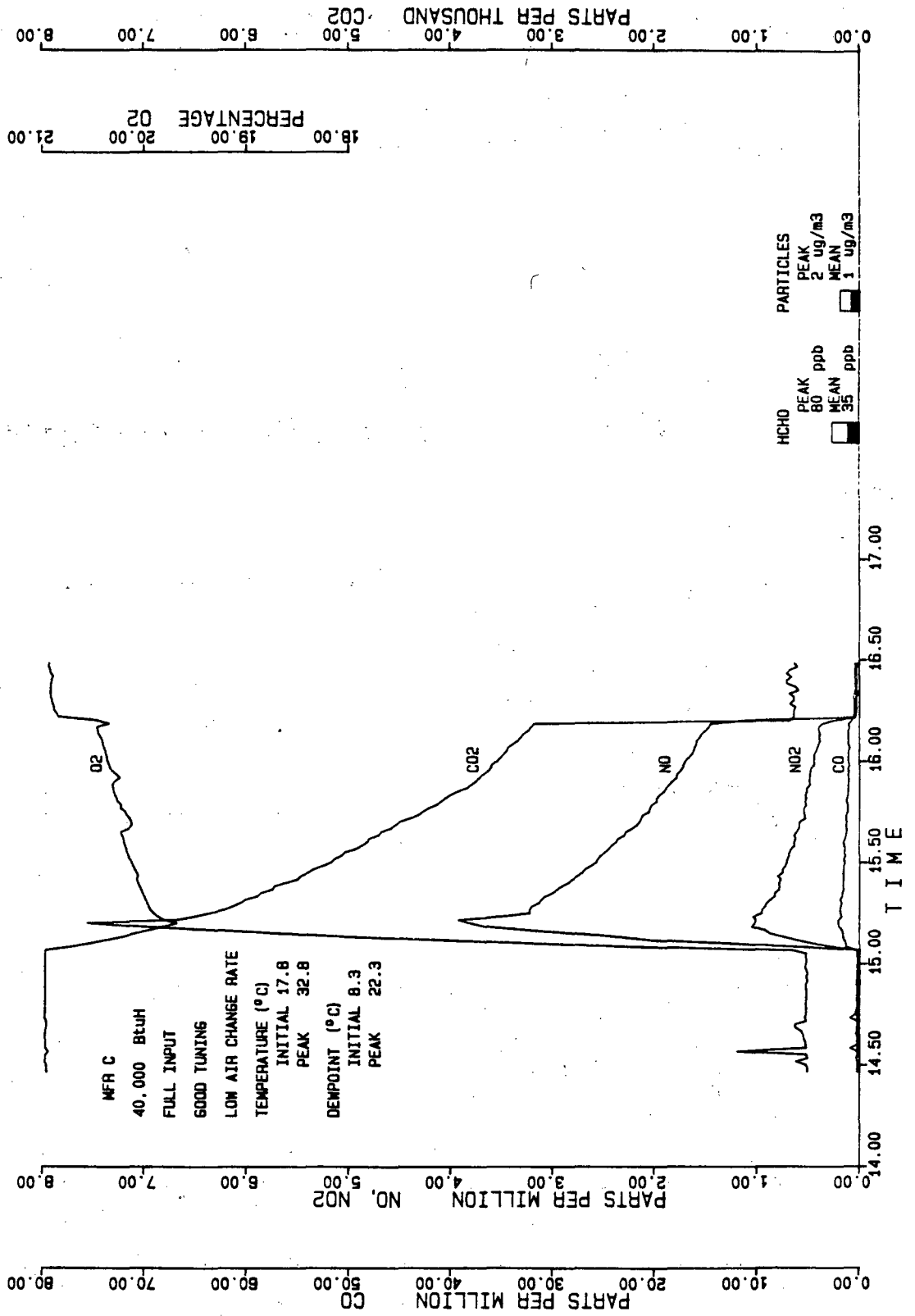

6

-91V-

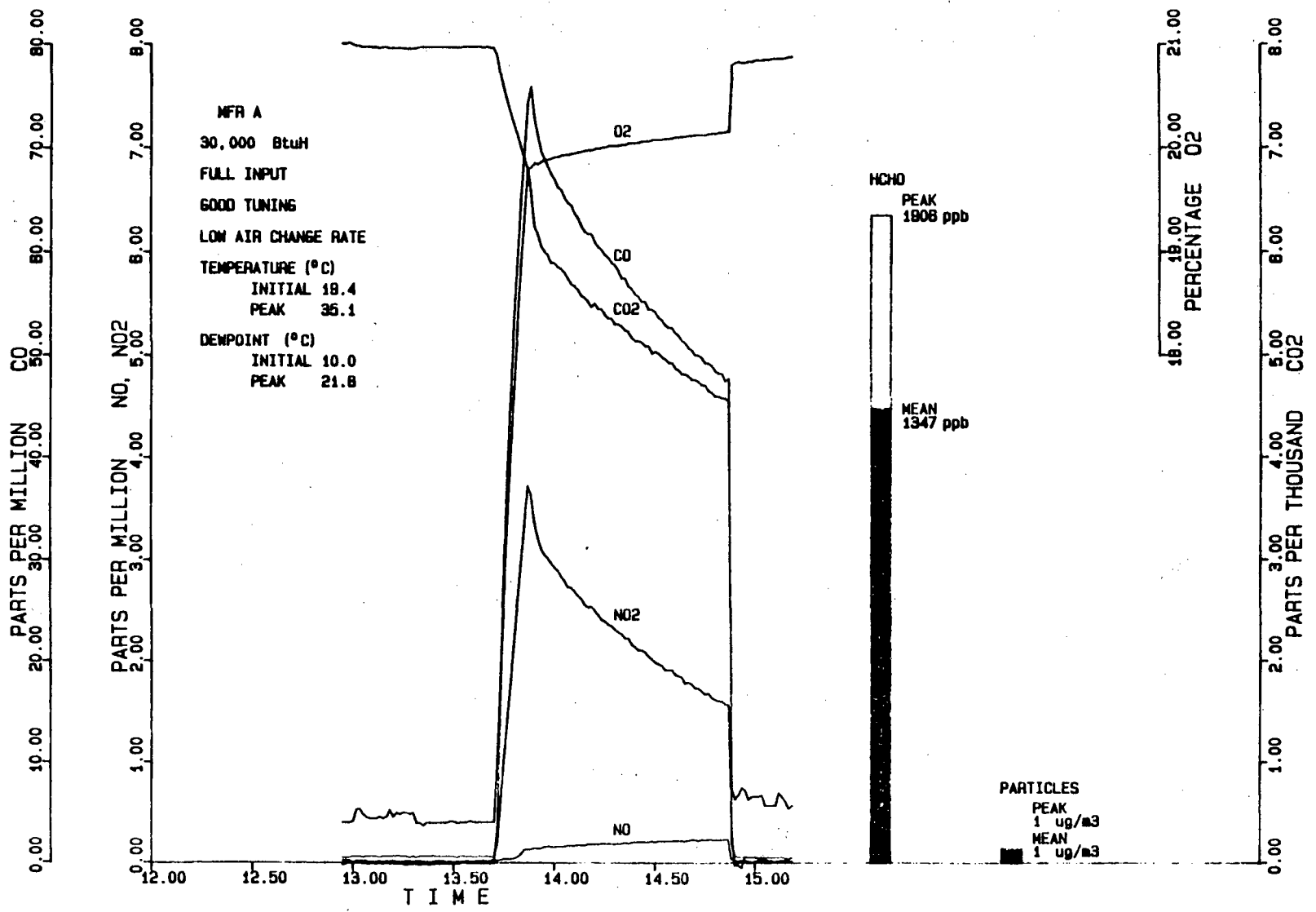

-A17-

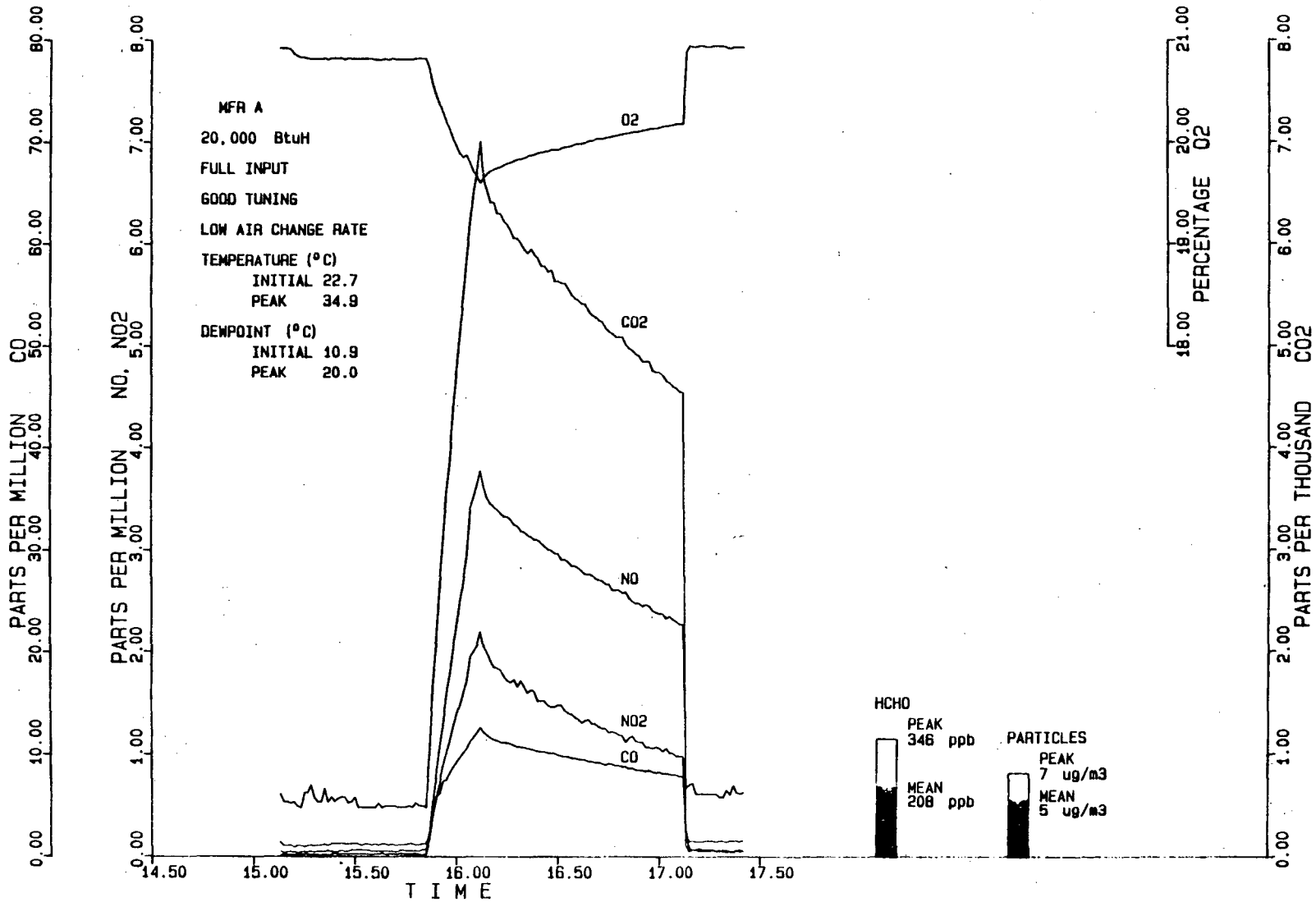

-A18-

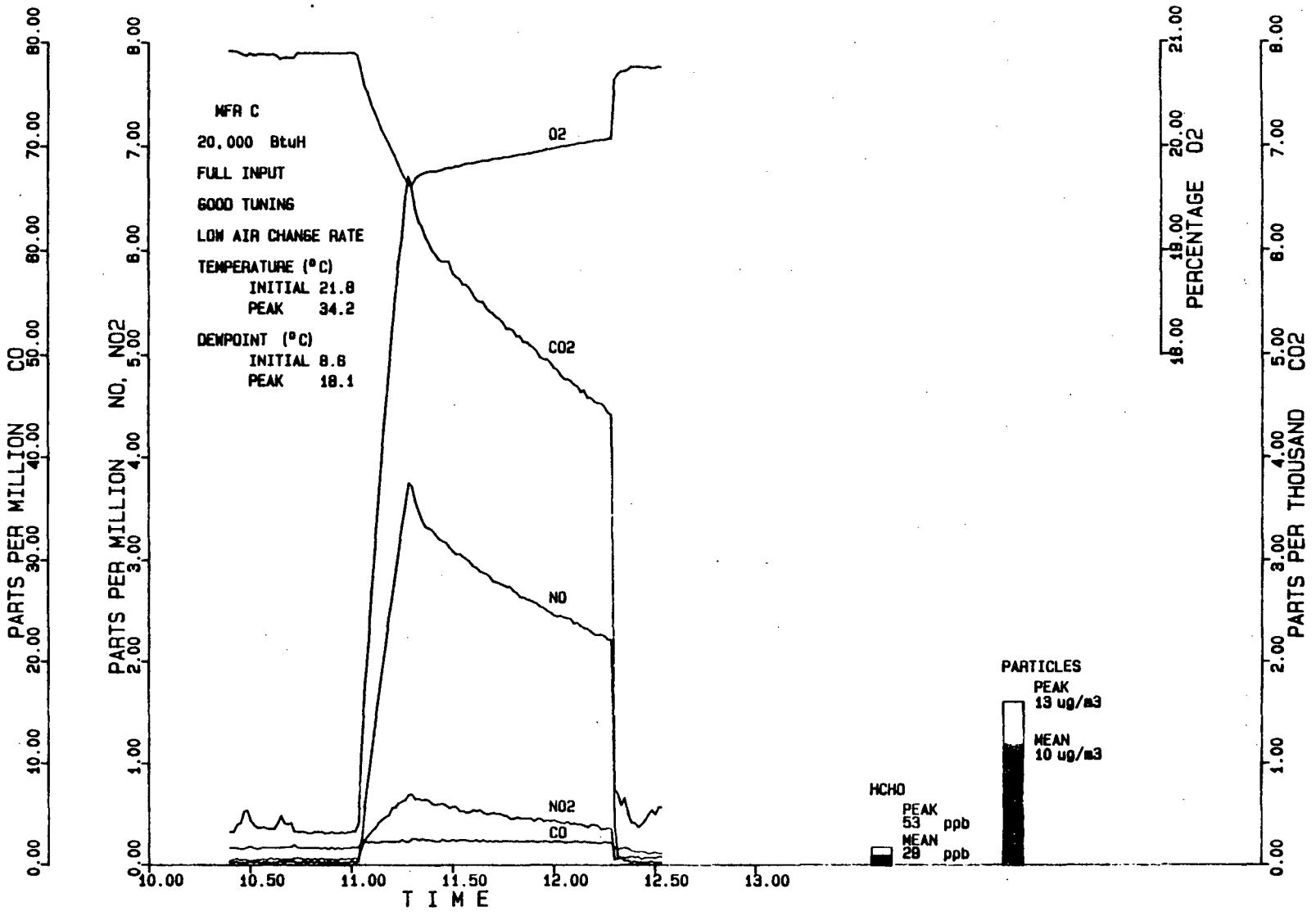

-61V-

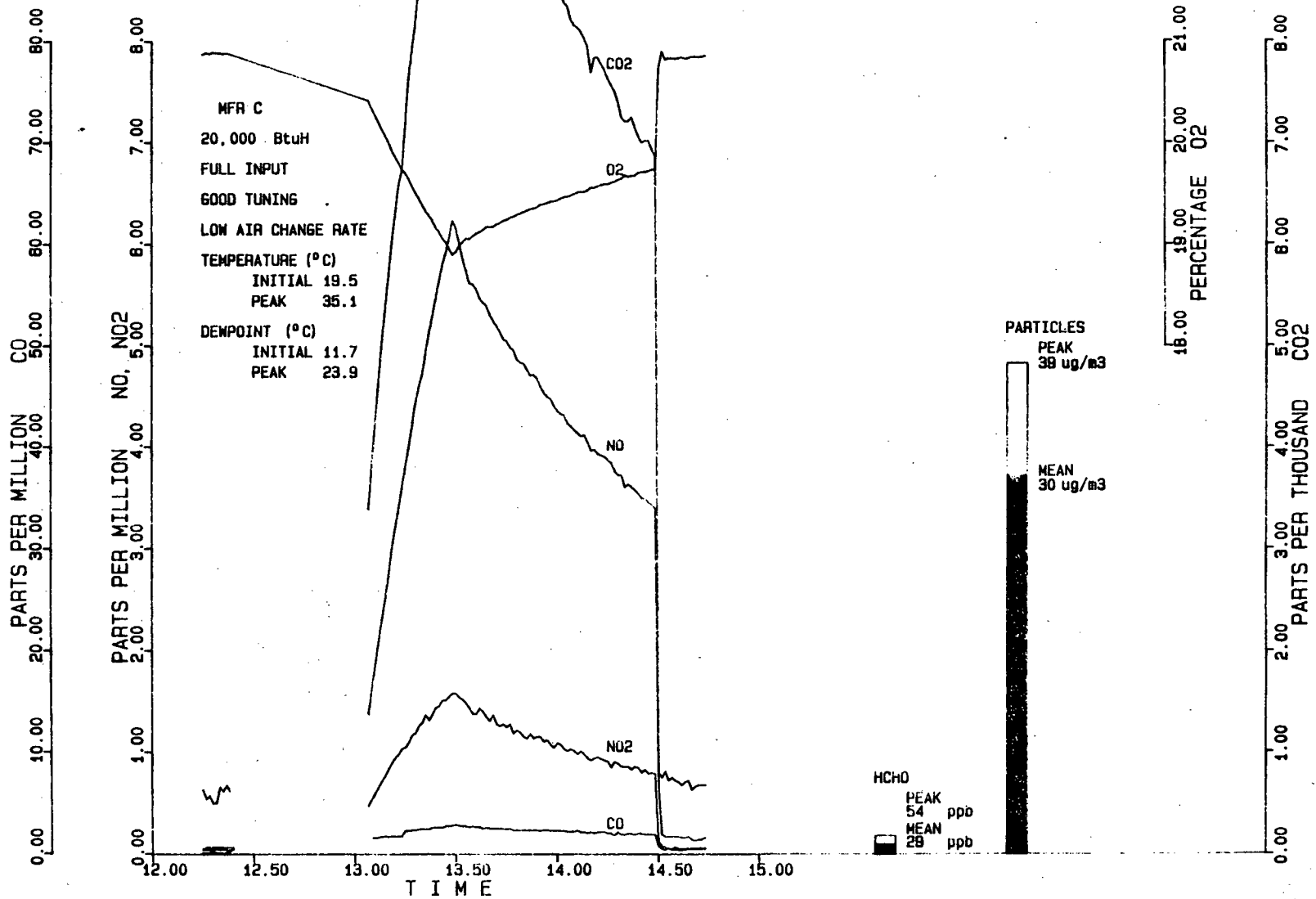

-A20-

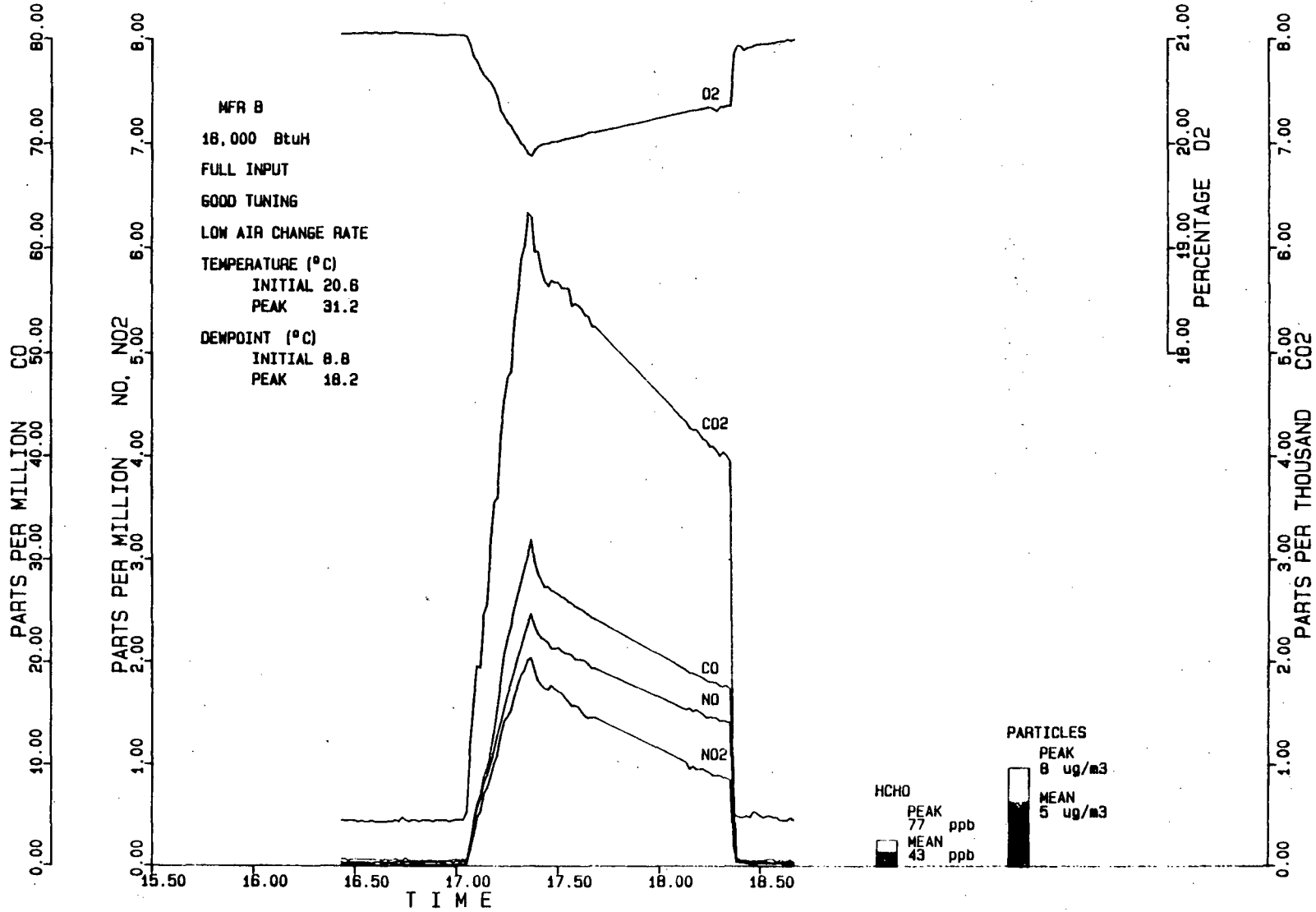

-A21-

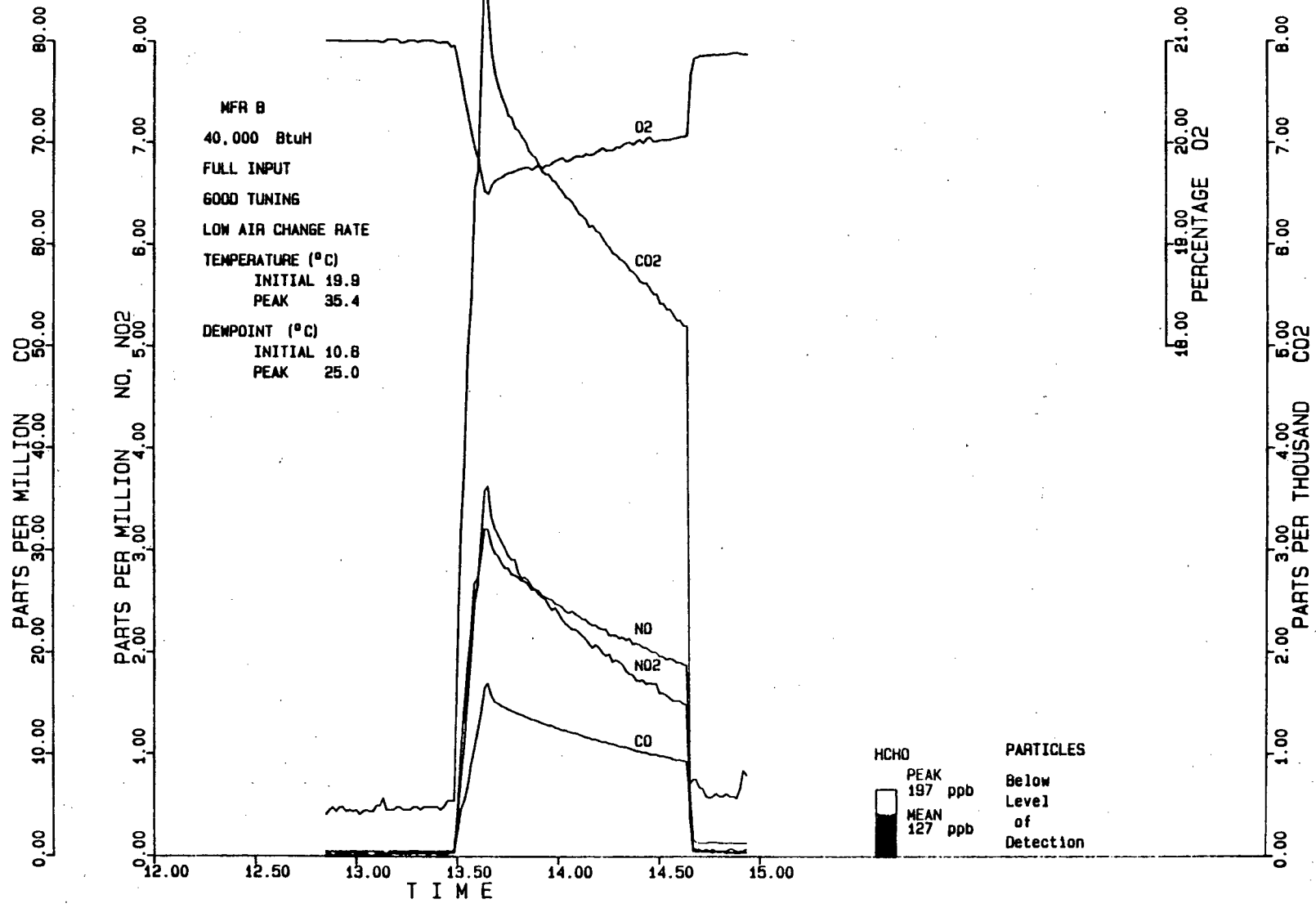

-A22-

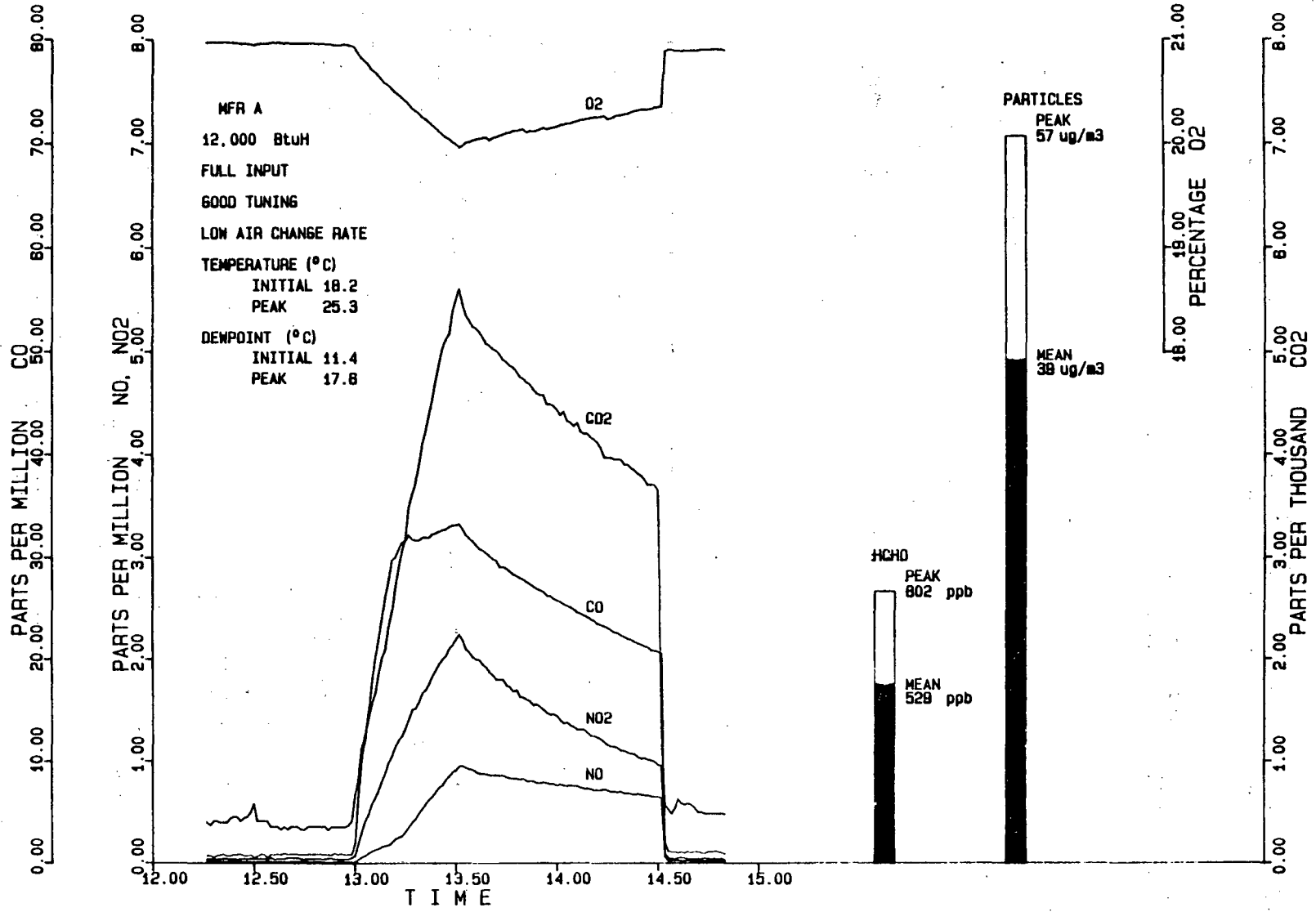

-A23-

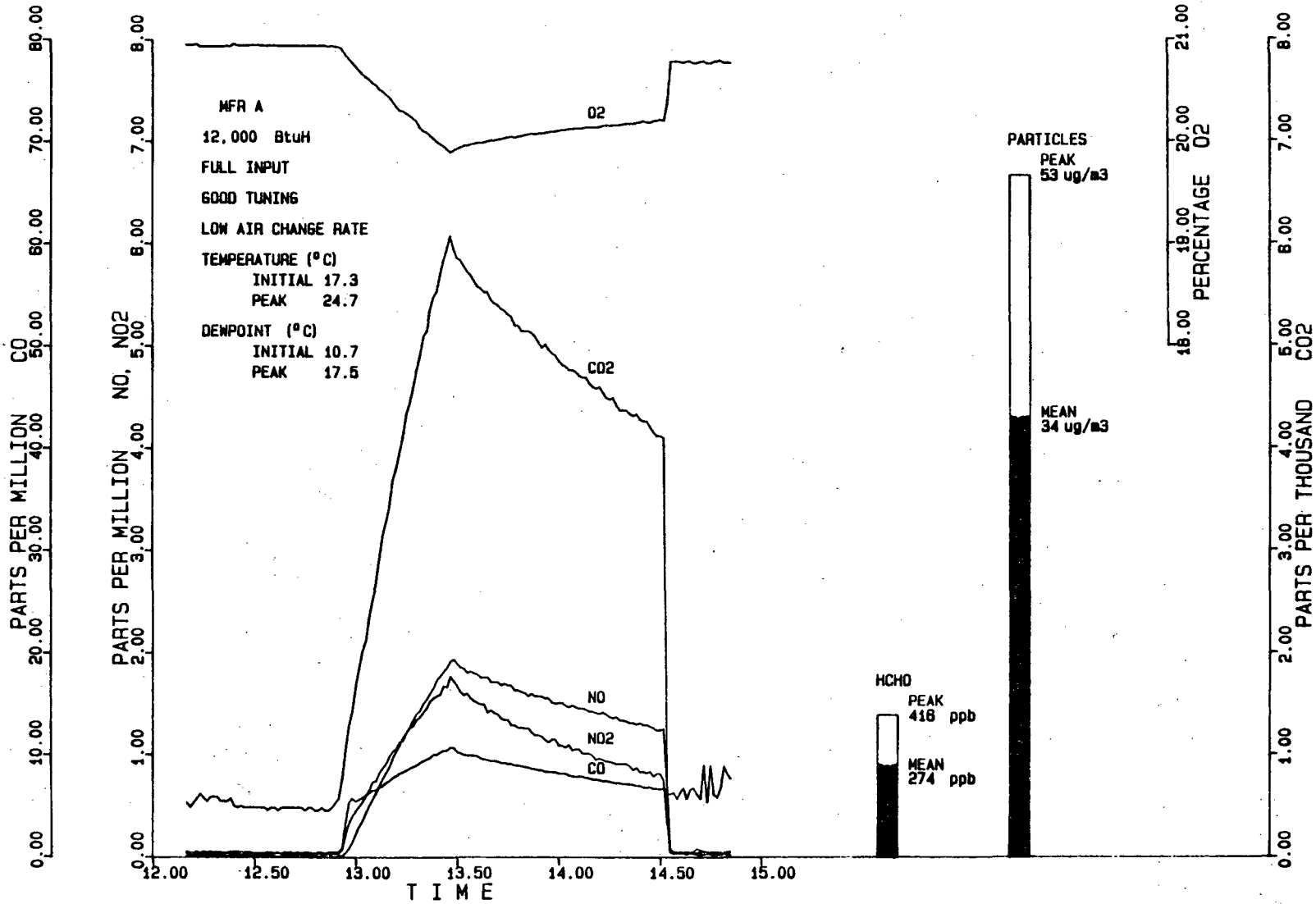

-A24-

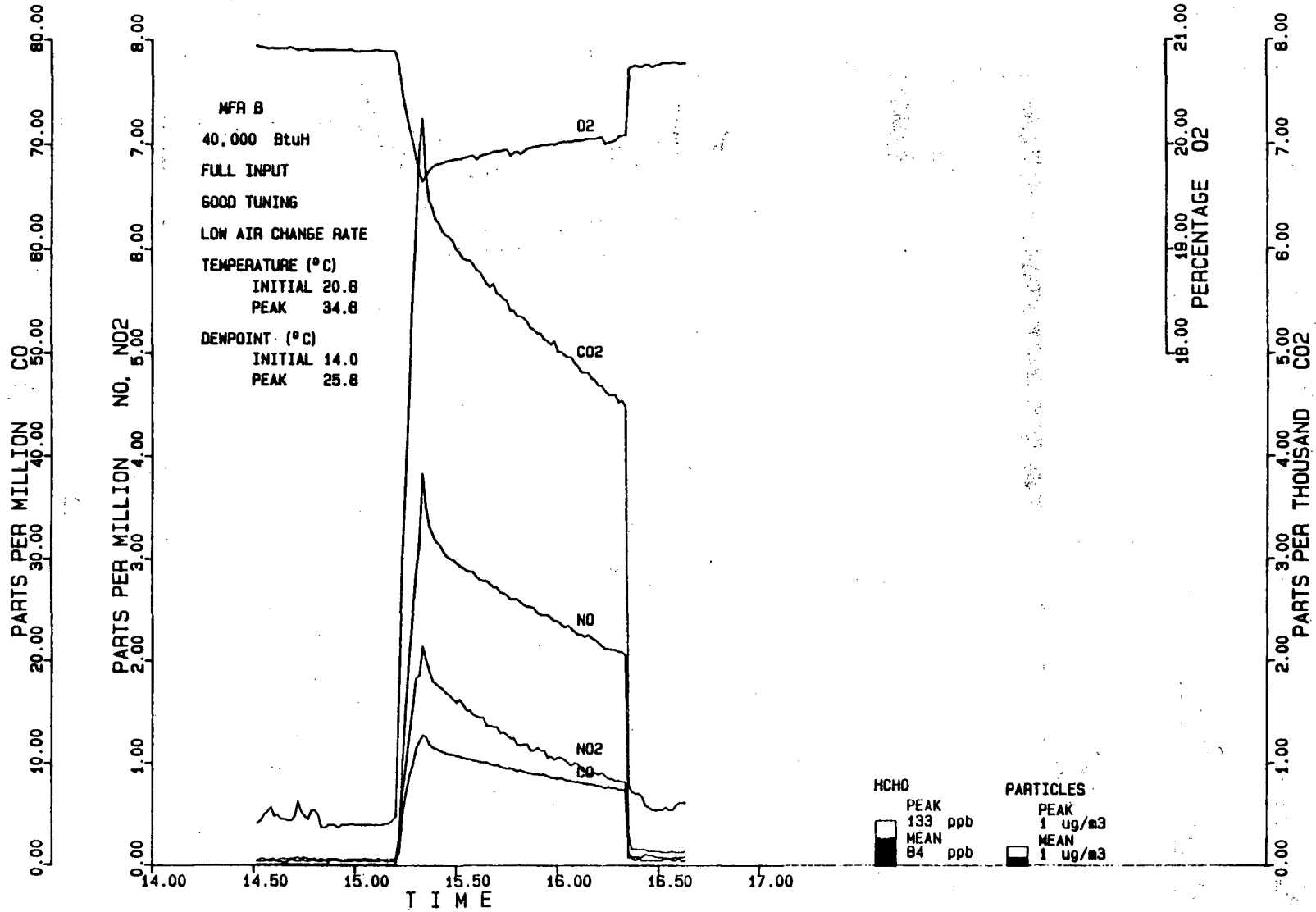

-A25-

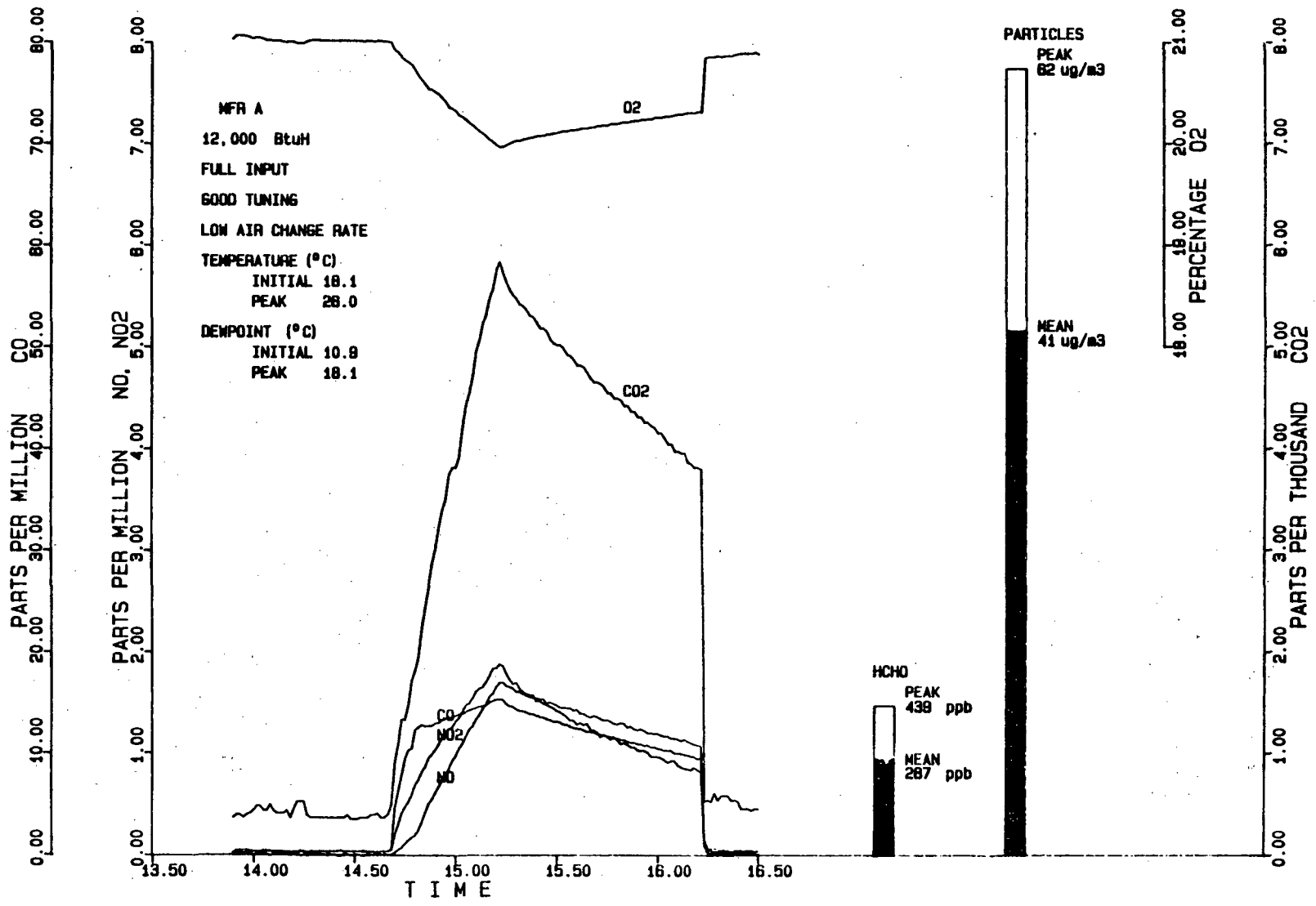

-A26-

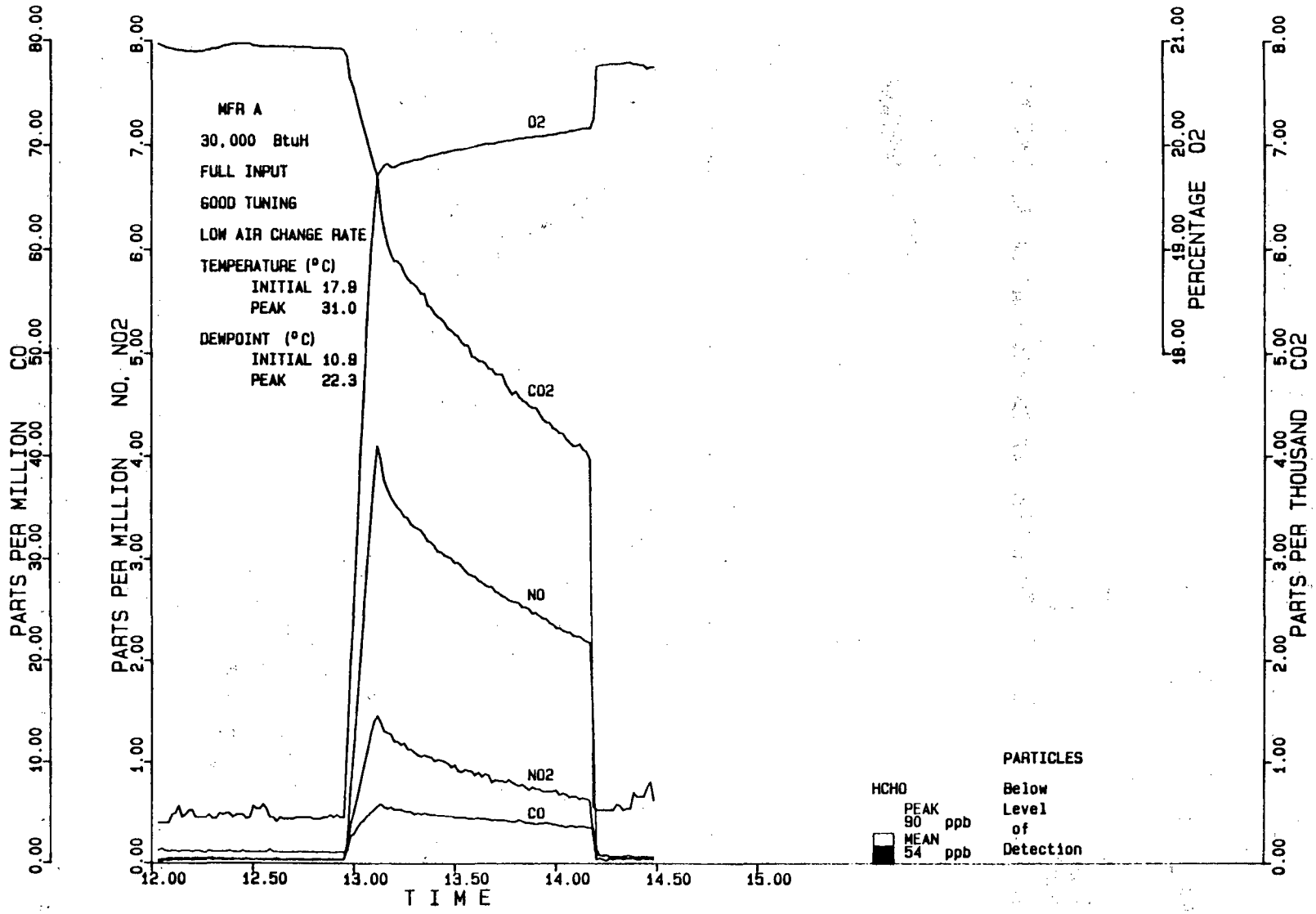

-A27-

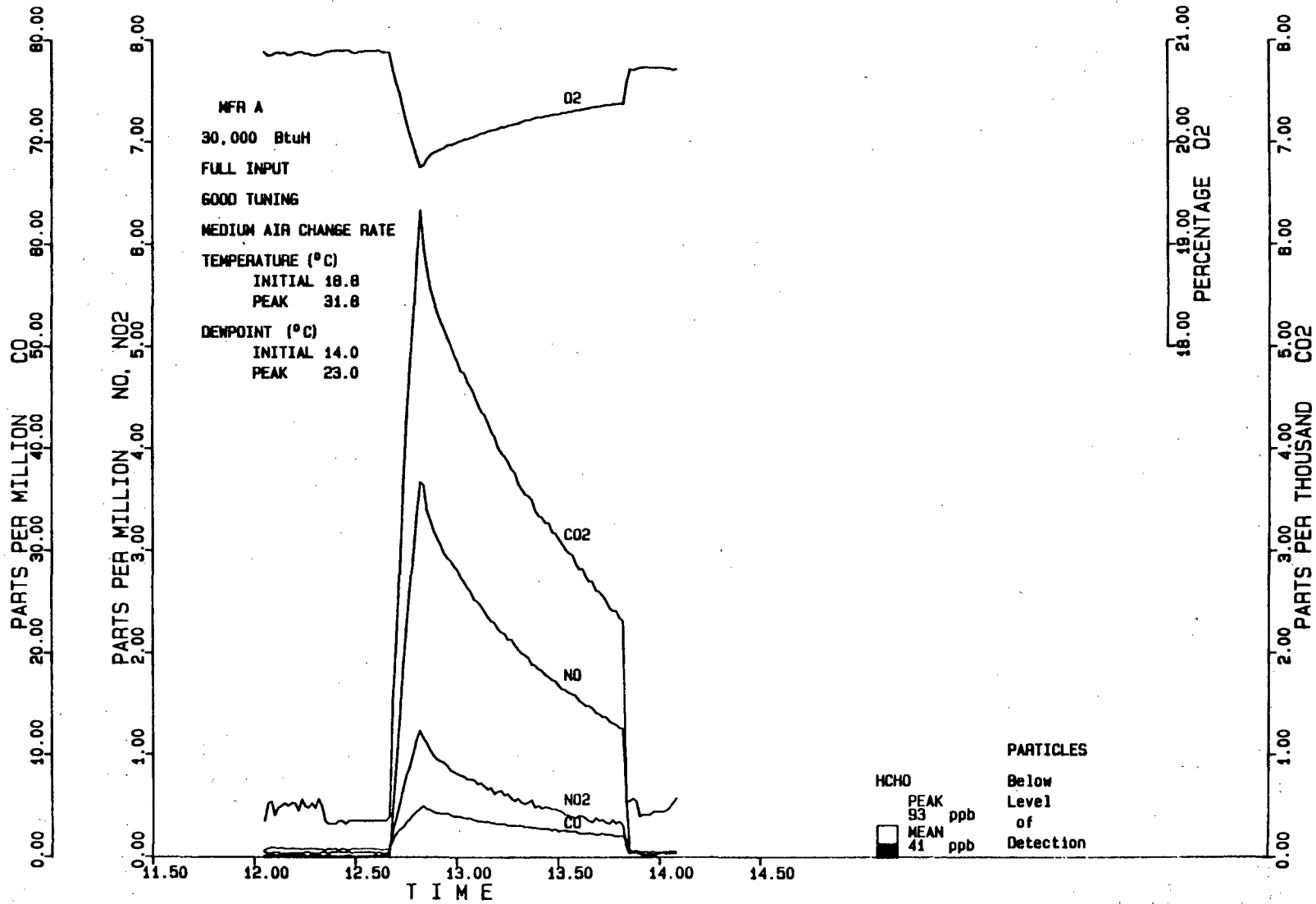

22

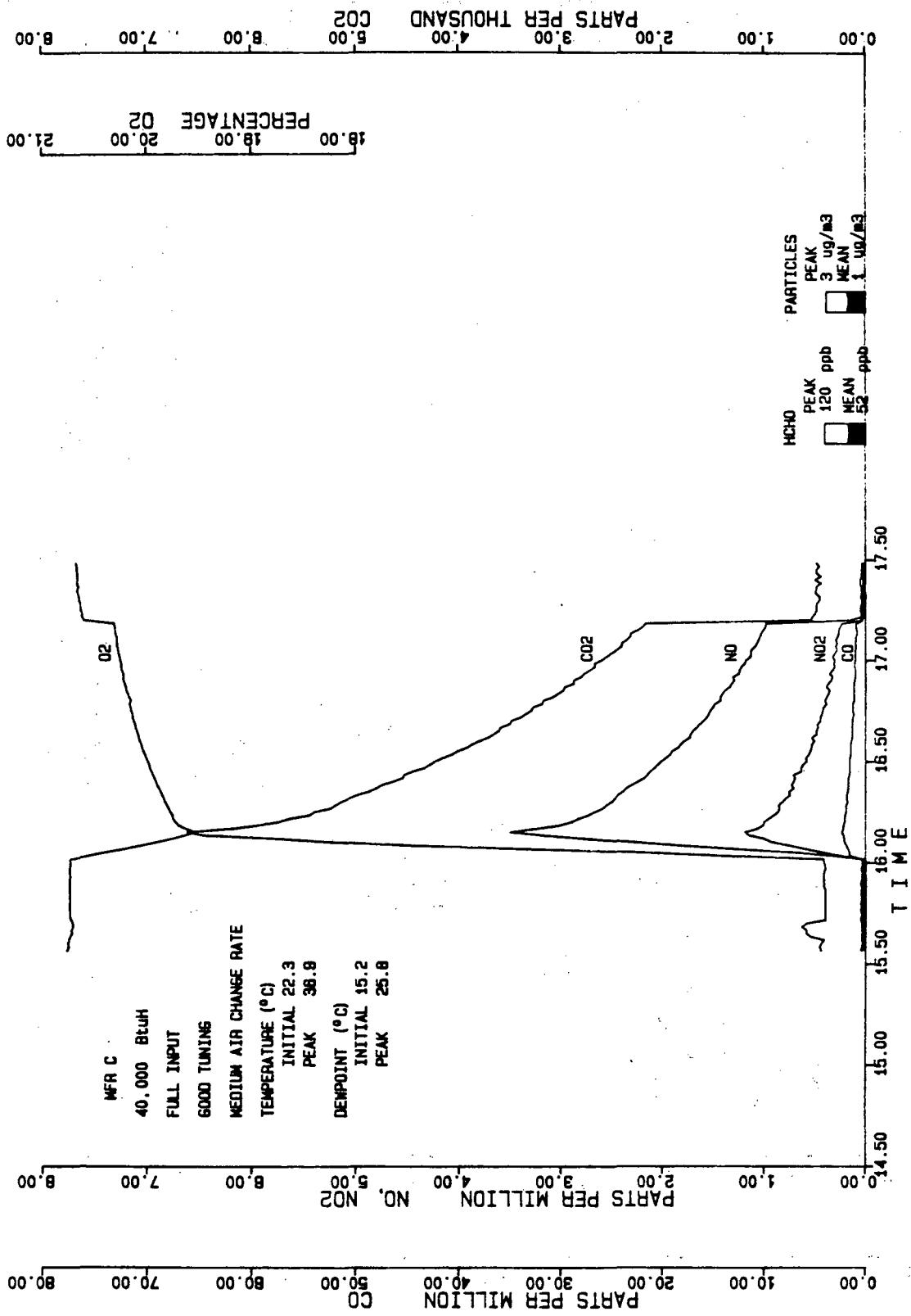

23

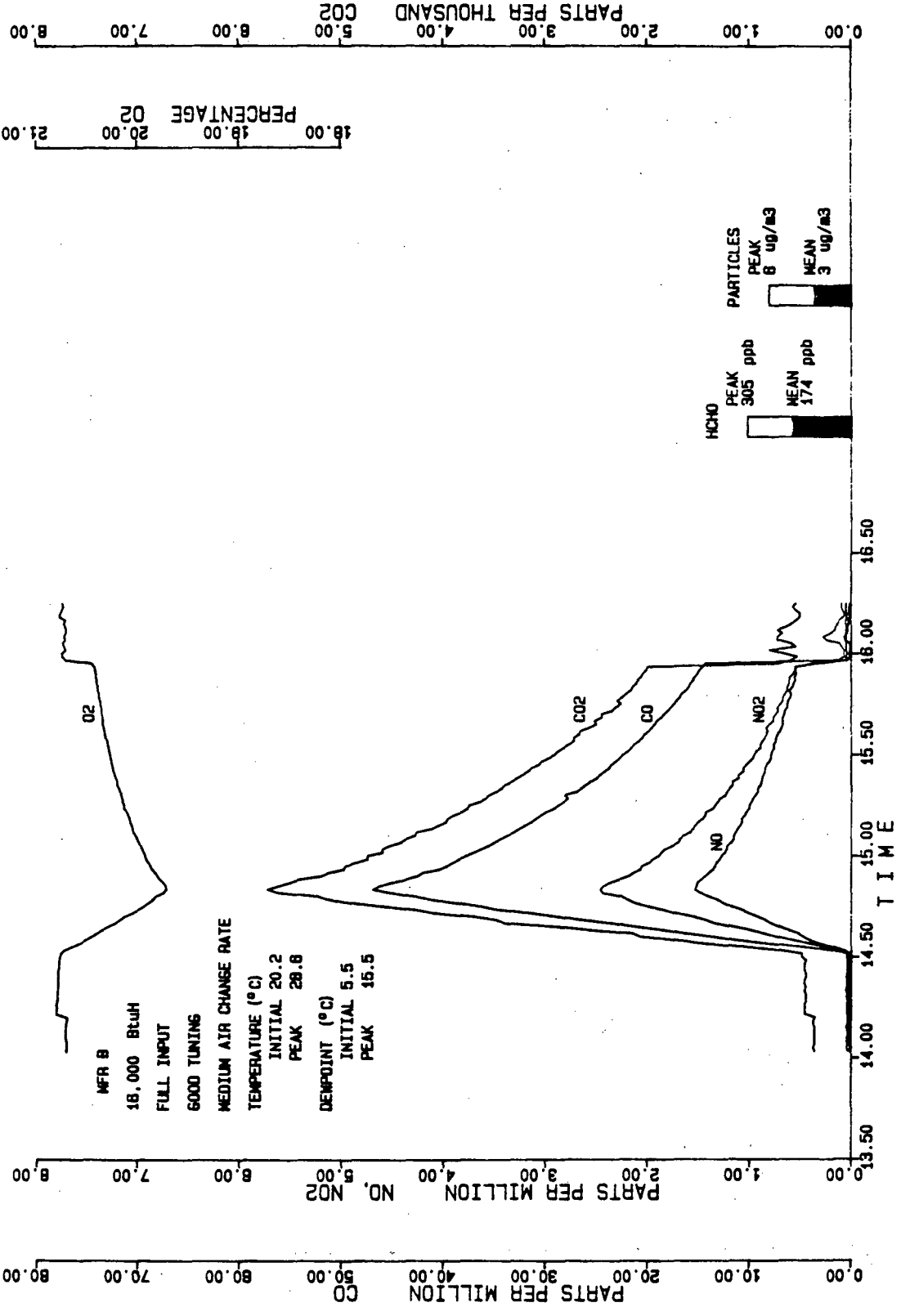

-A30-

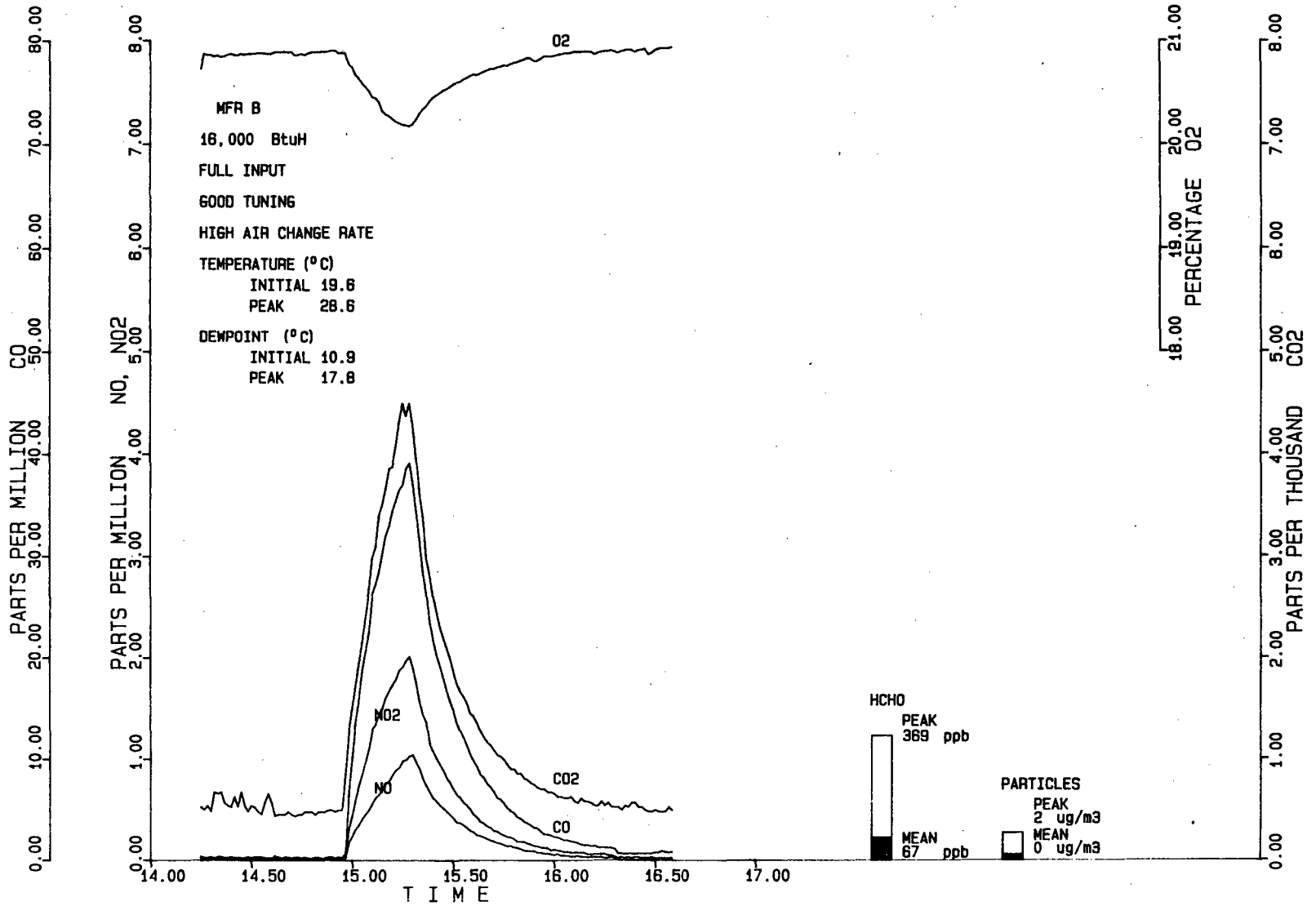

-131-

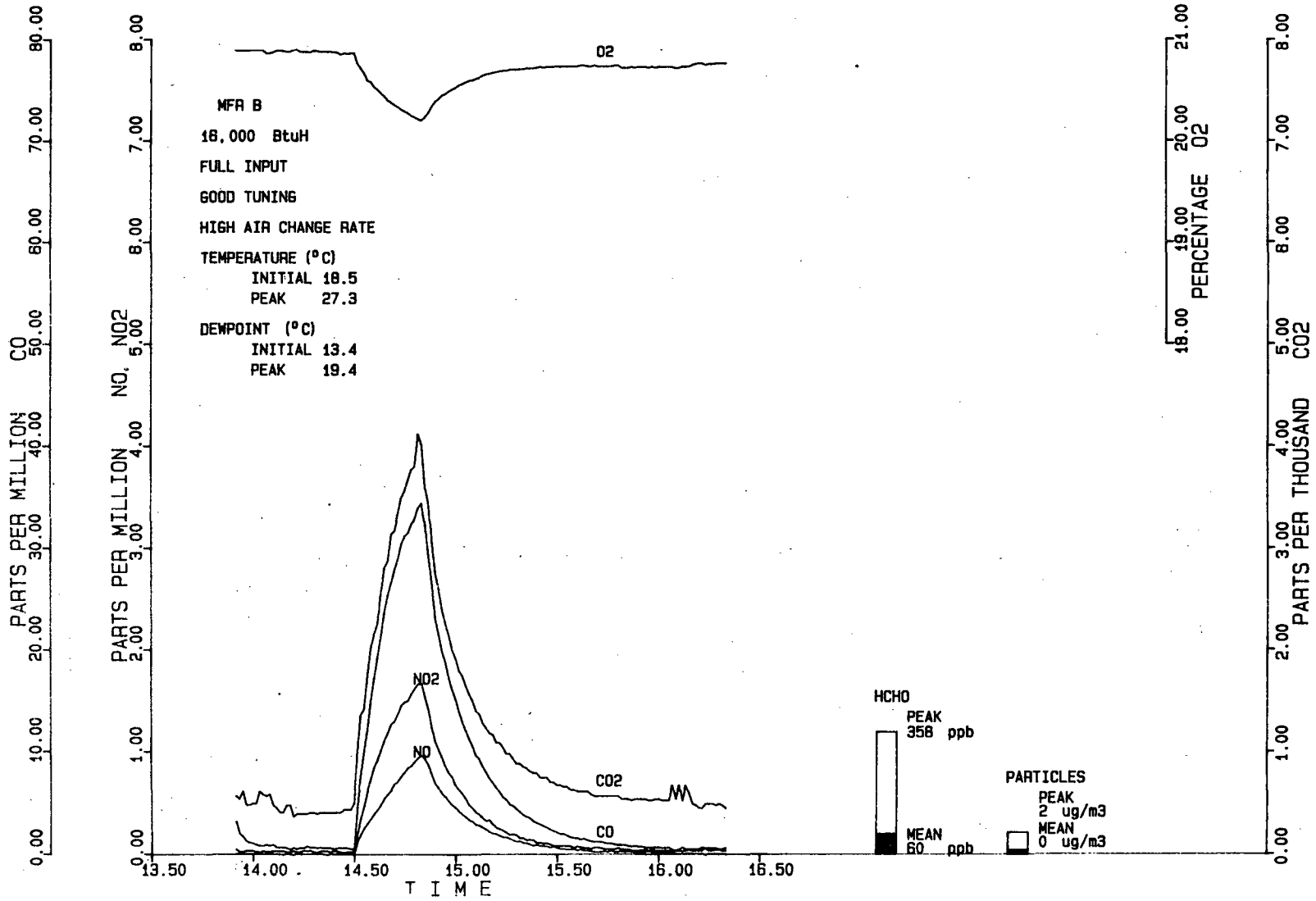

-A32-

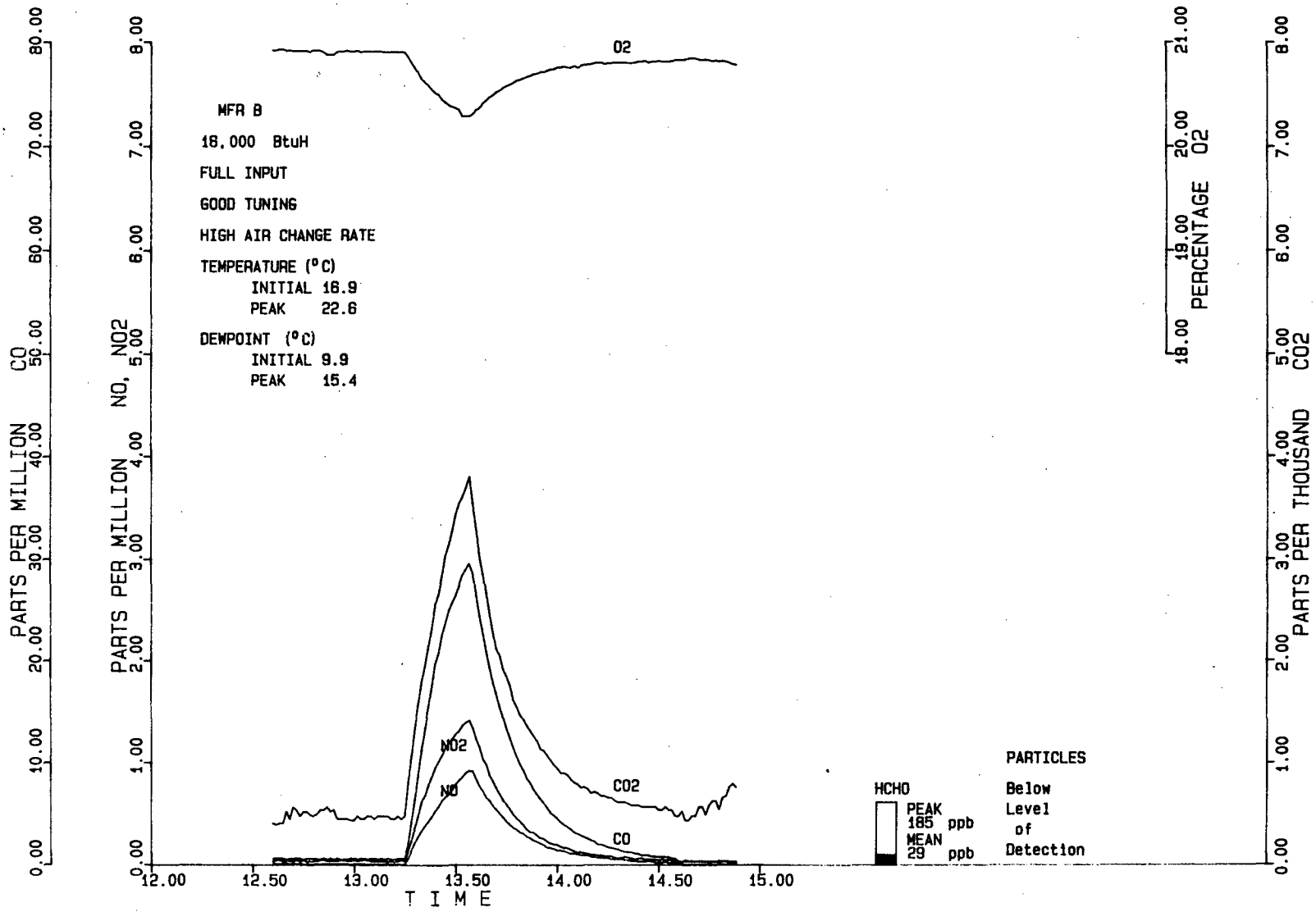

-A33-

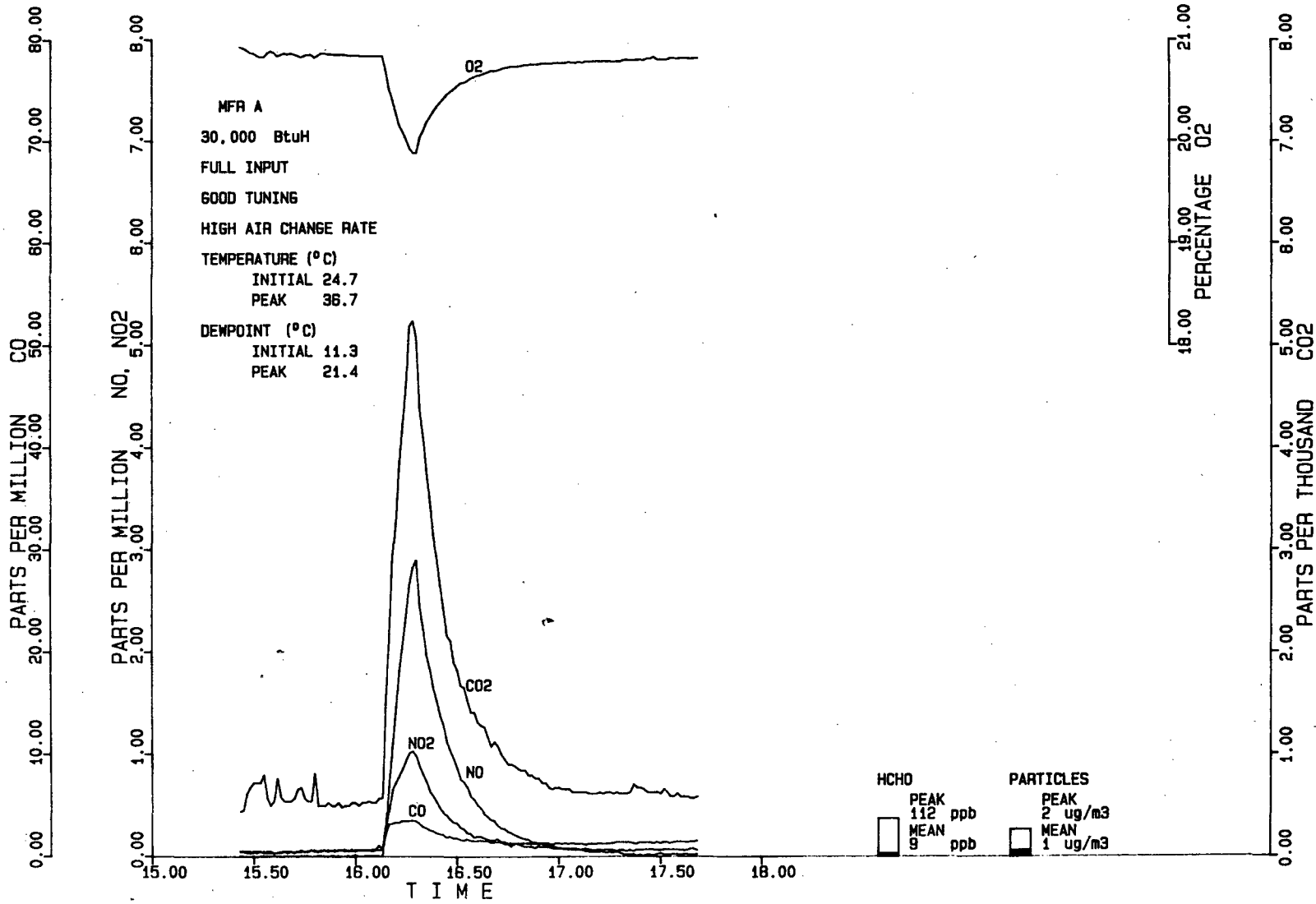

-A34-

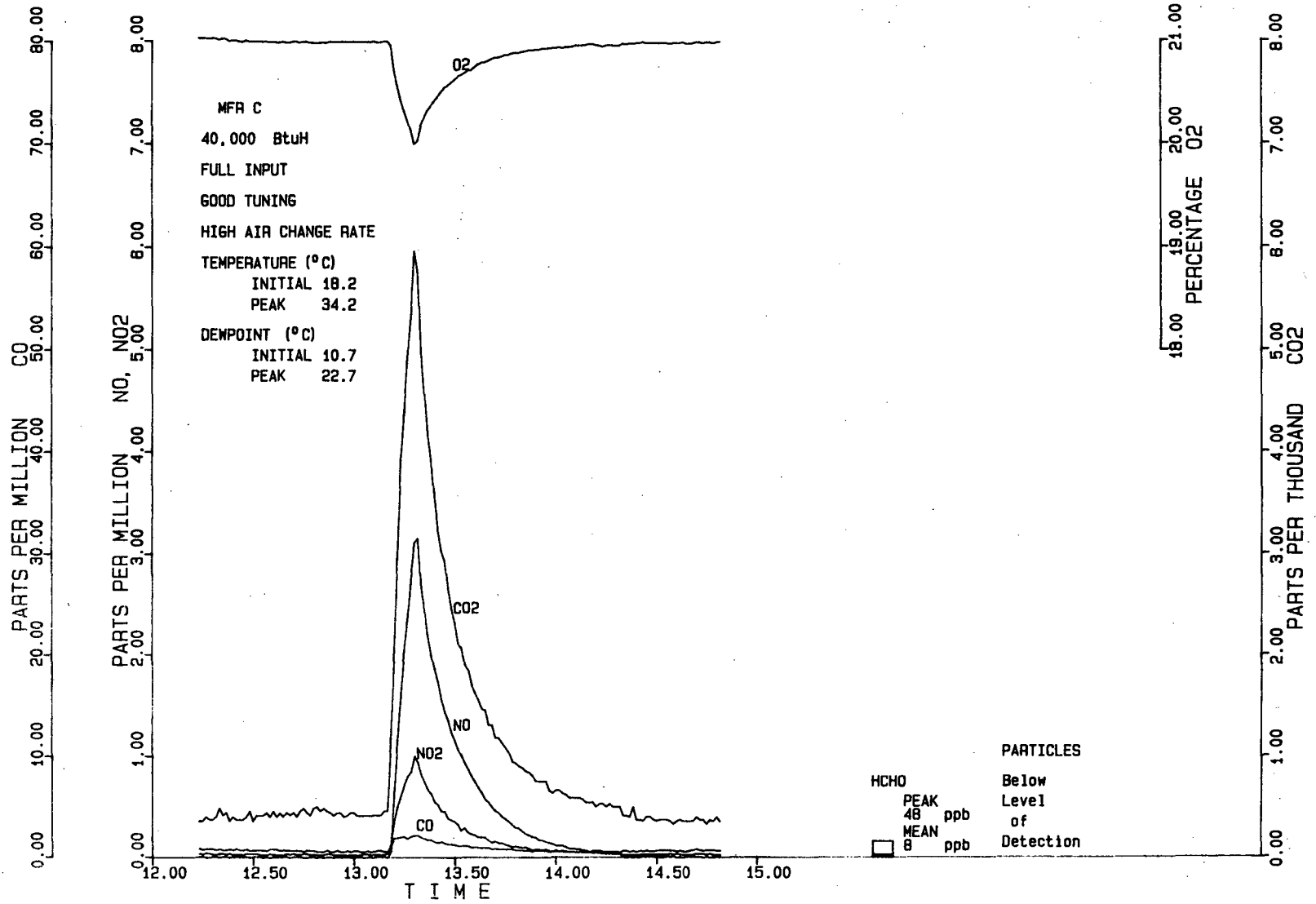

-A35-

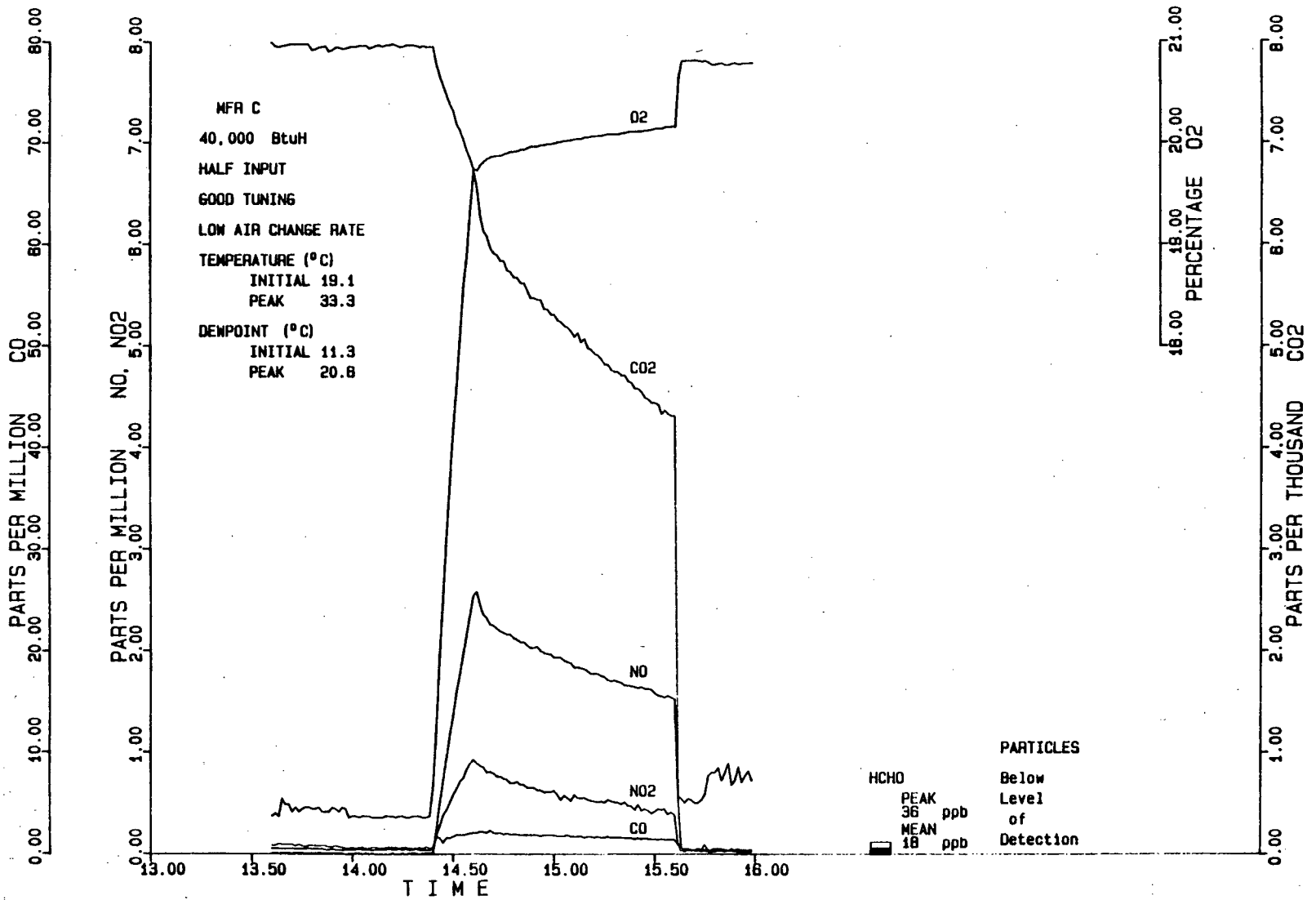

-A36-

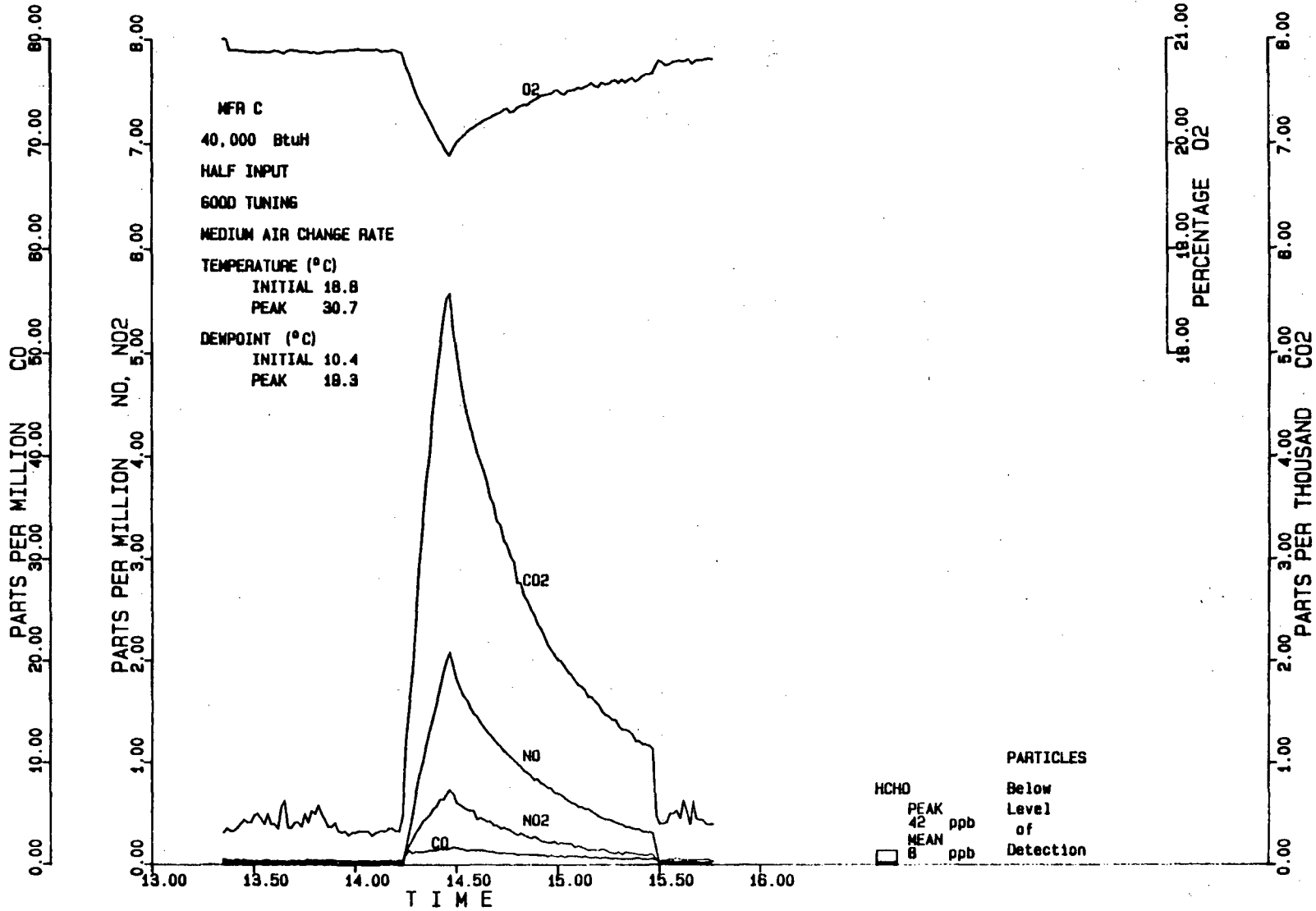

-A37-

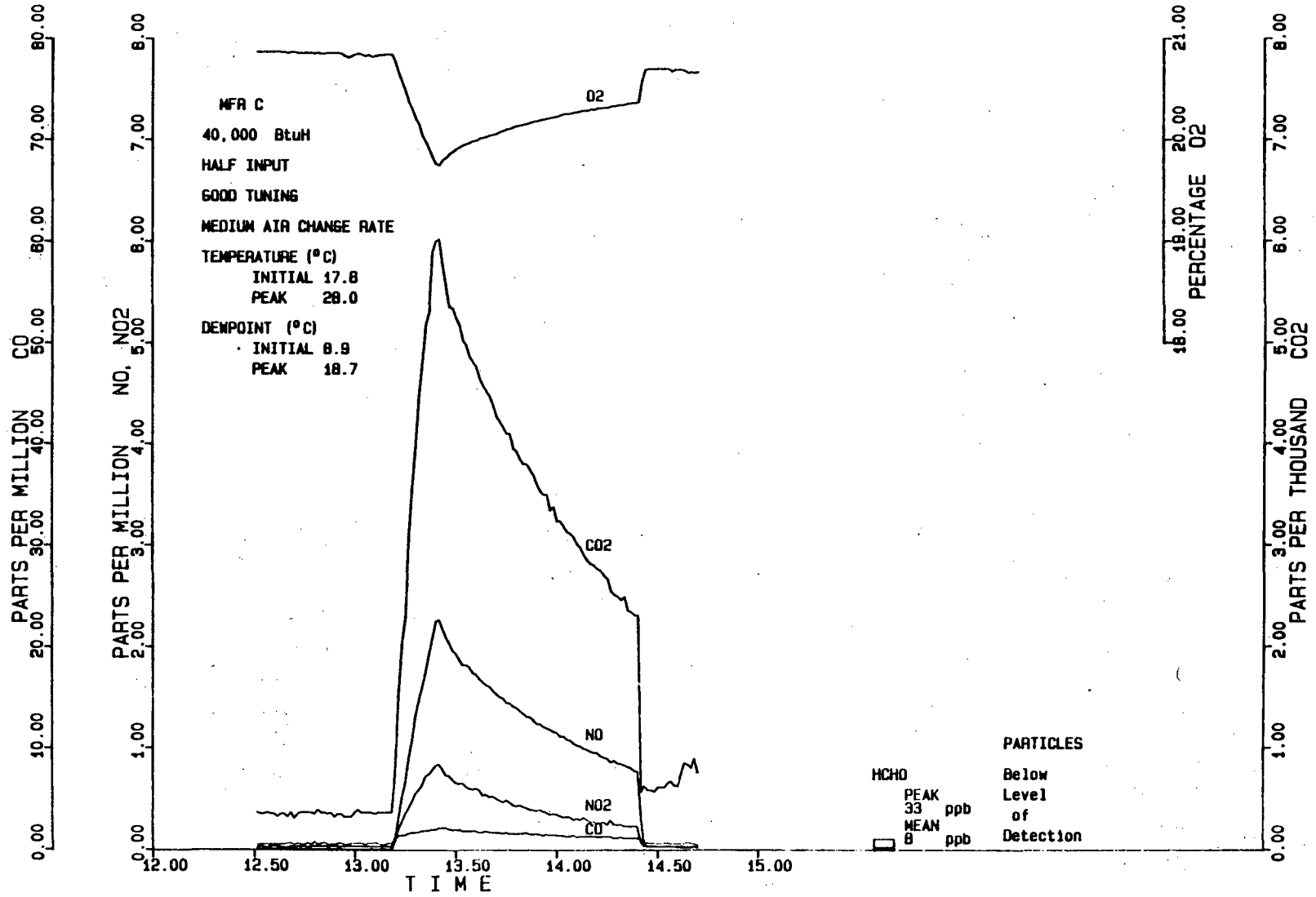

33

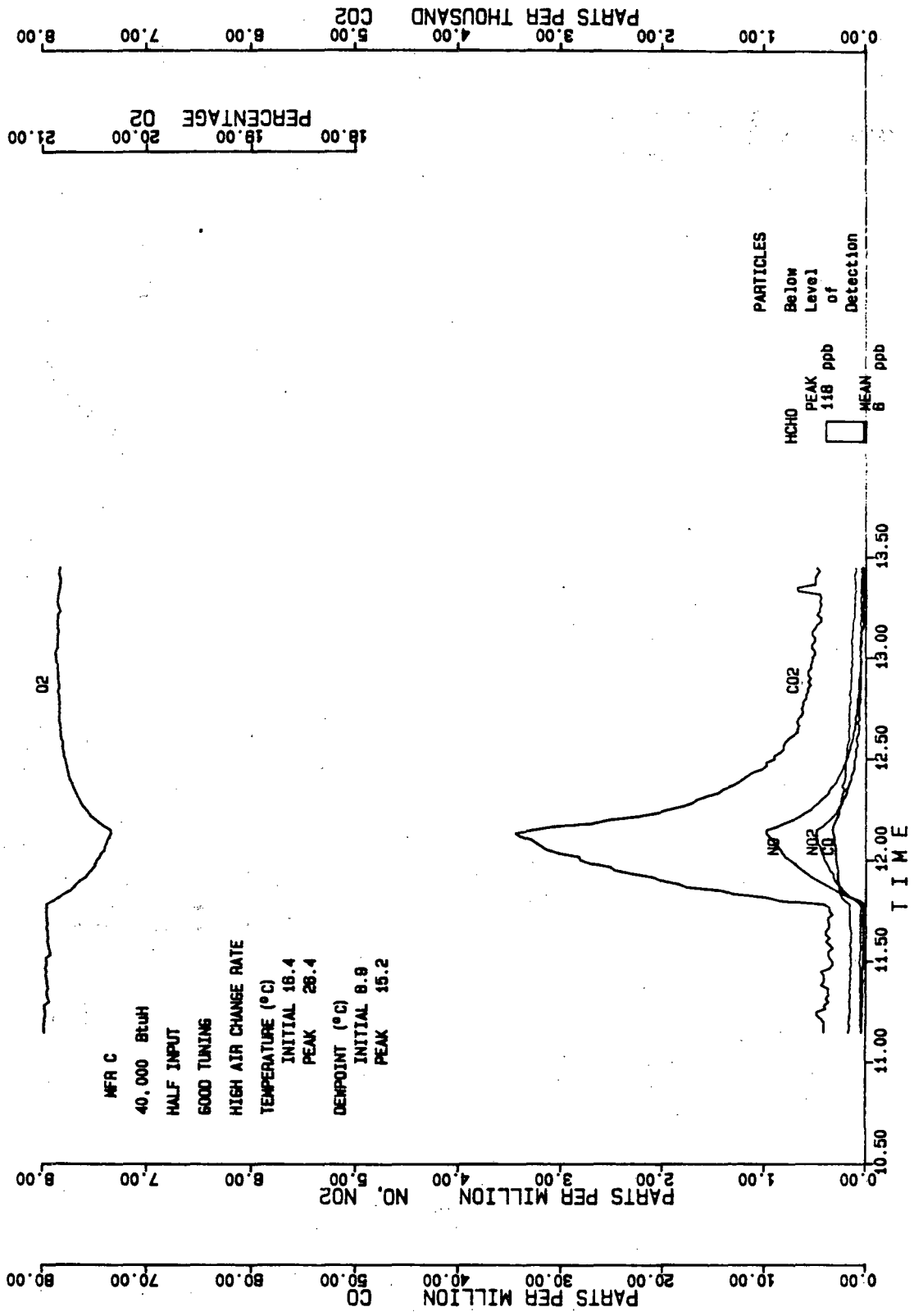

35

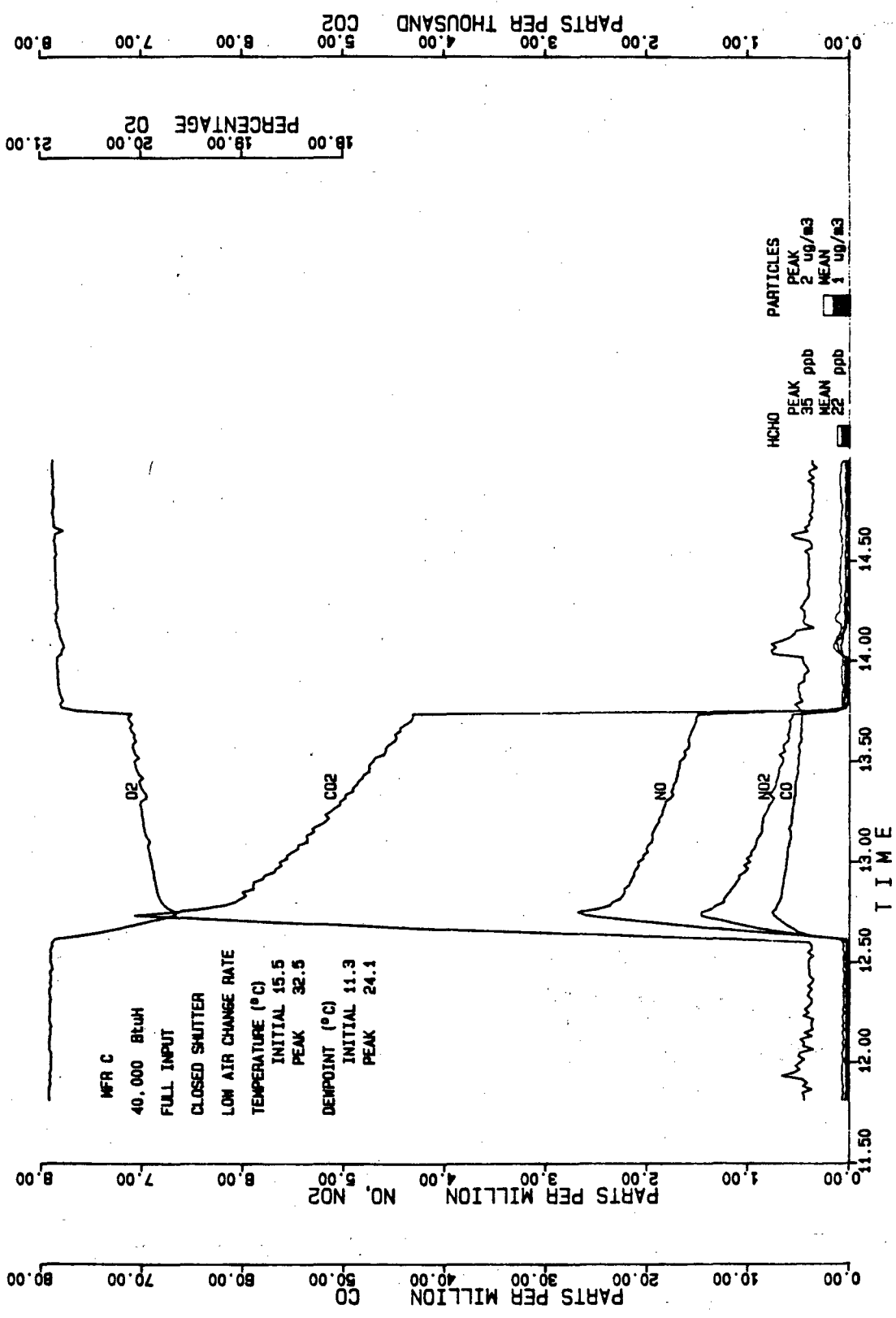

36

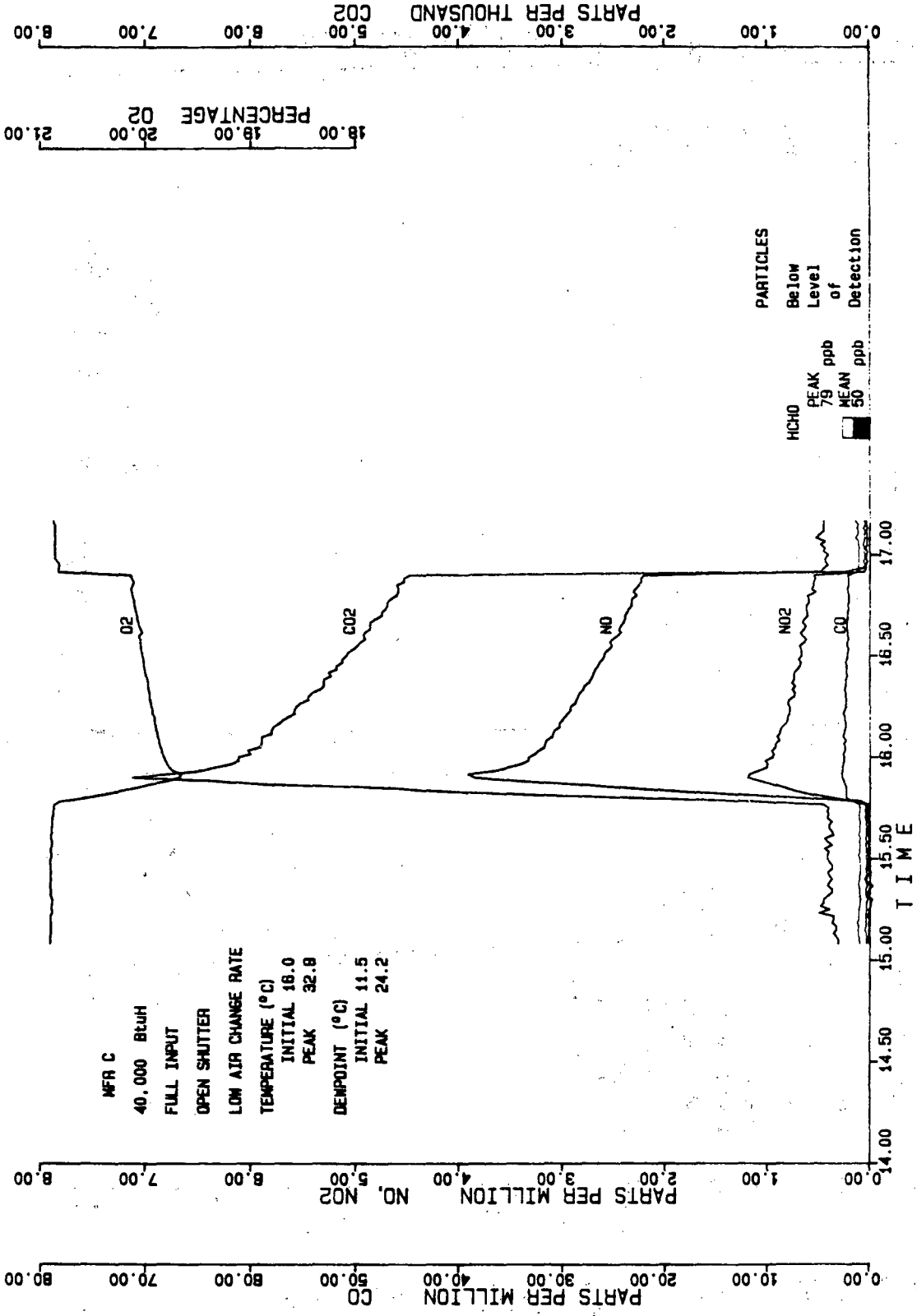

37

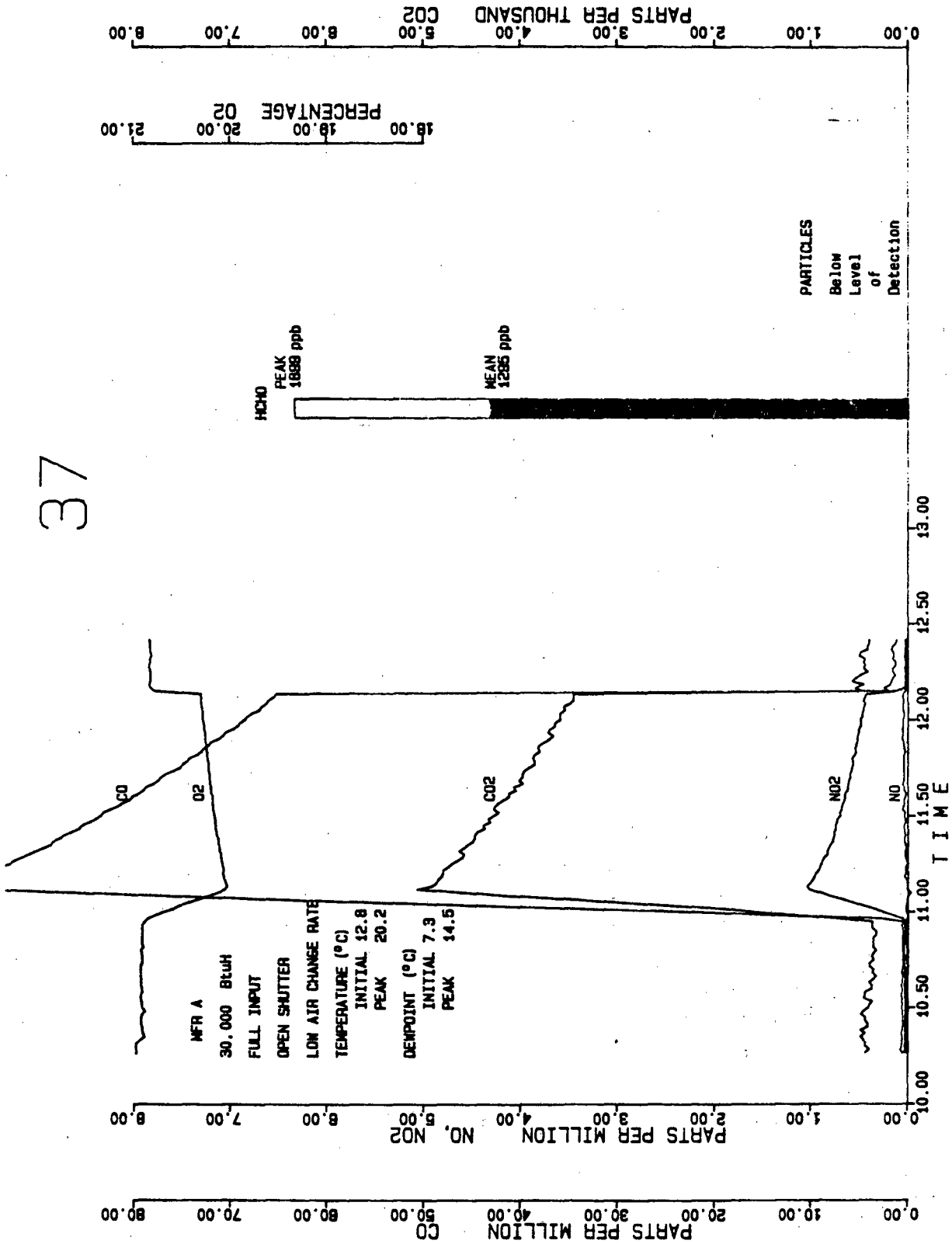

-A42-

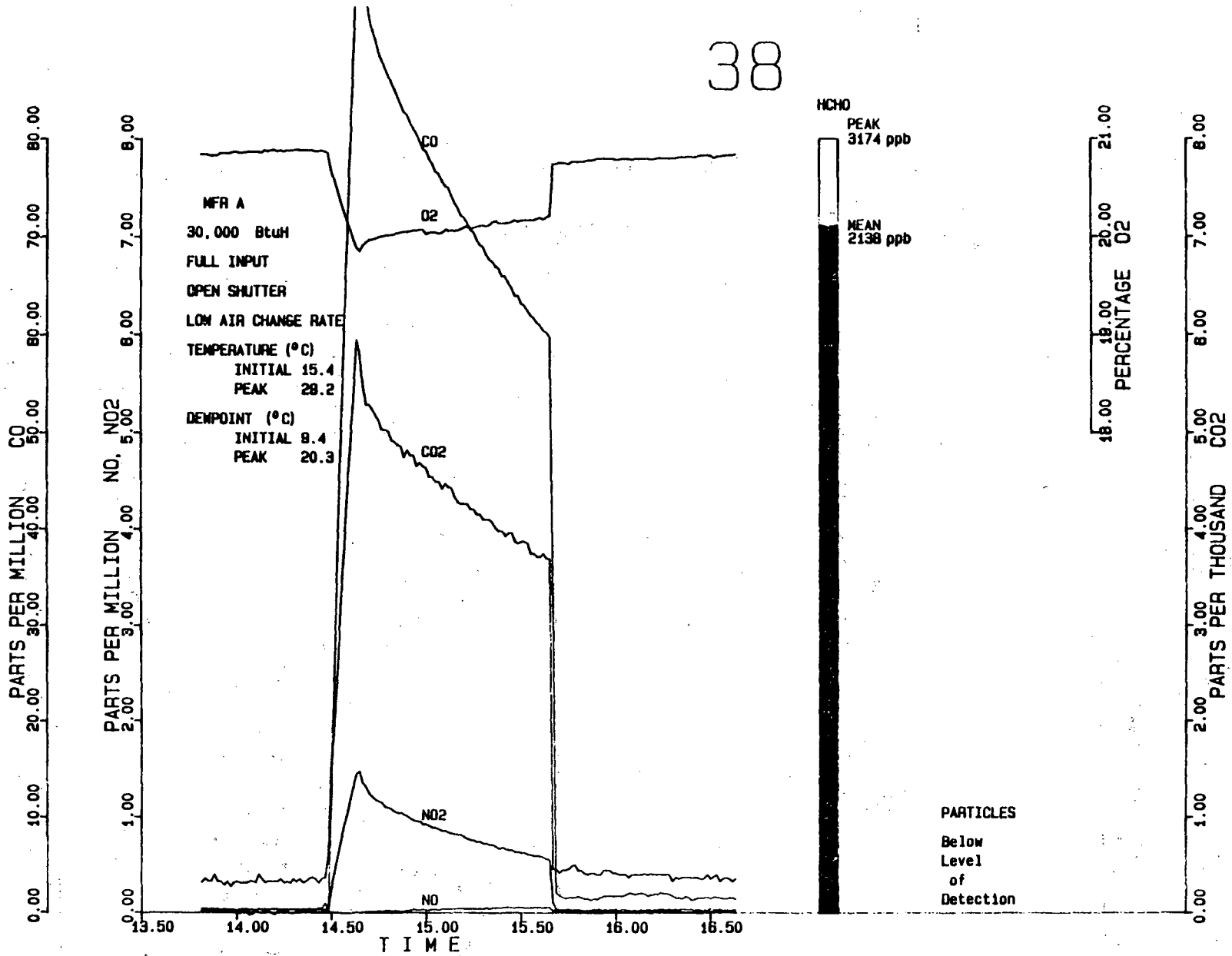

-A43-

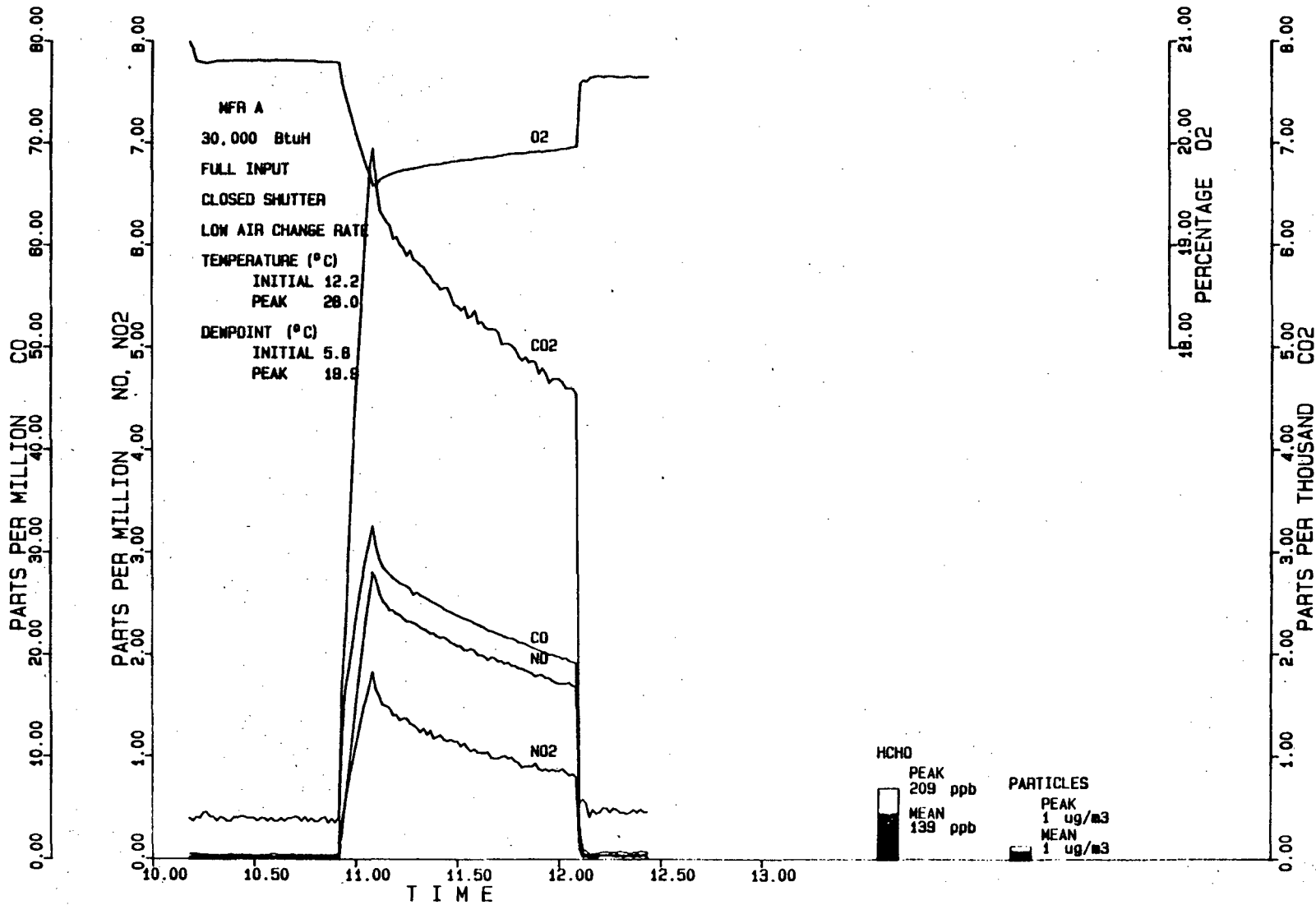

-44V-

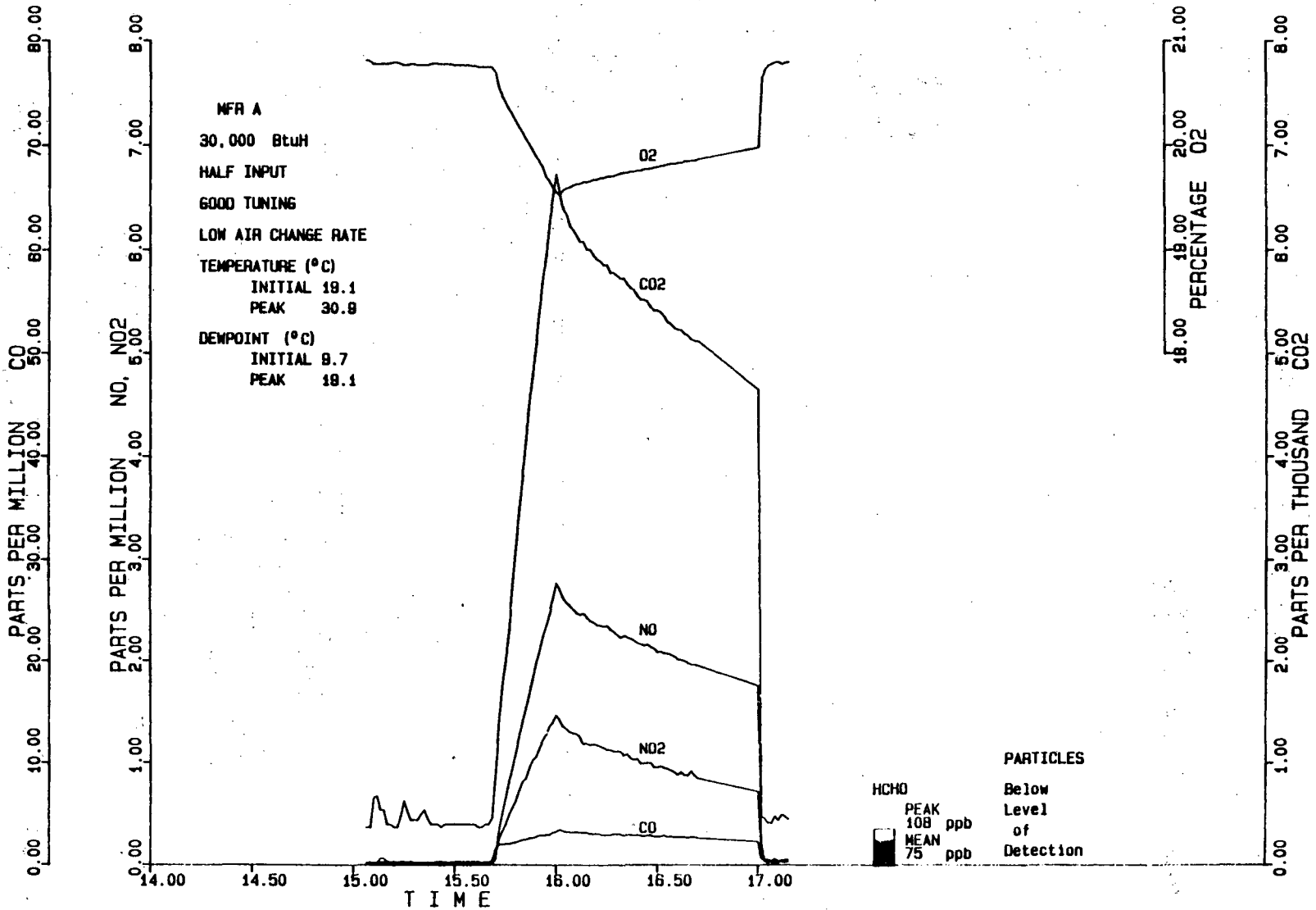

-A45-

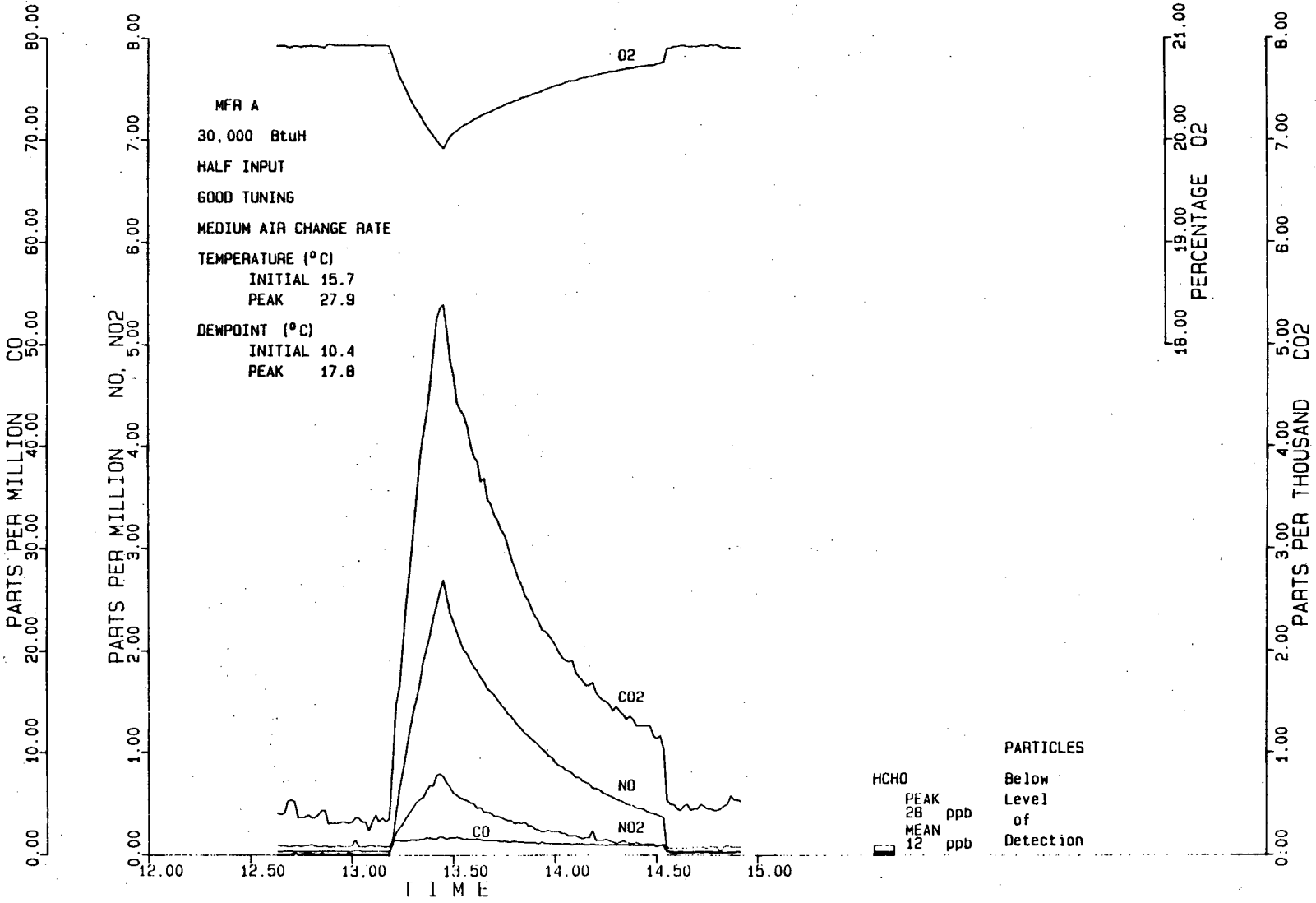

42

-A46-

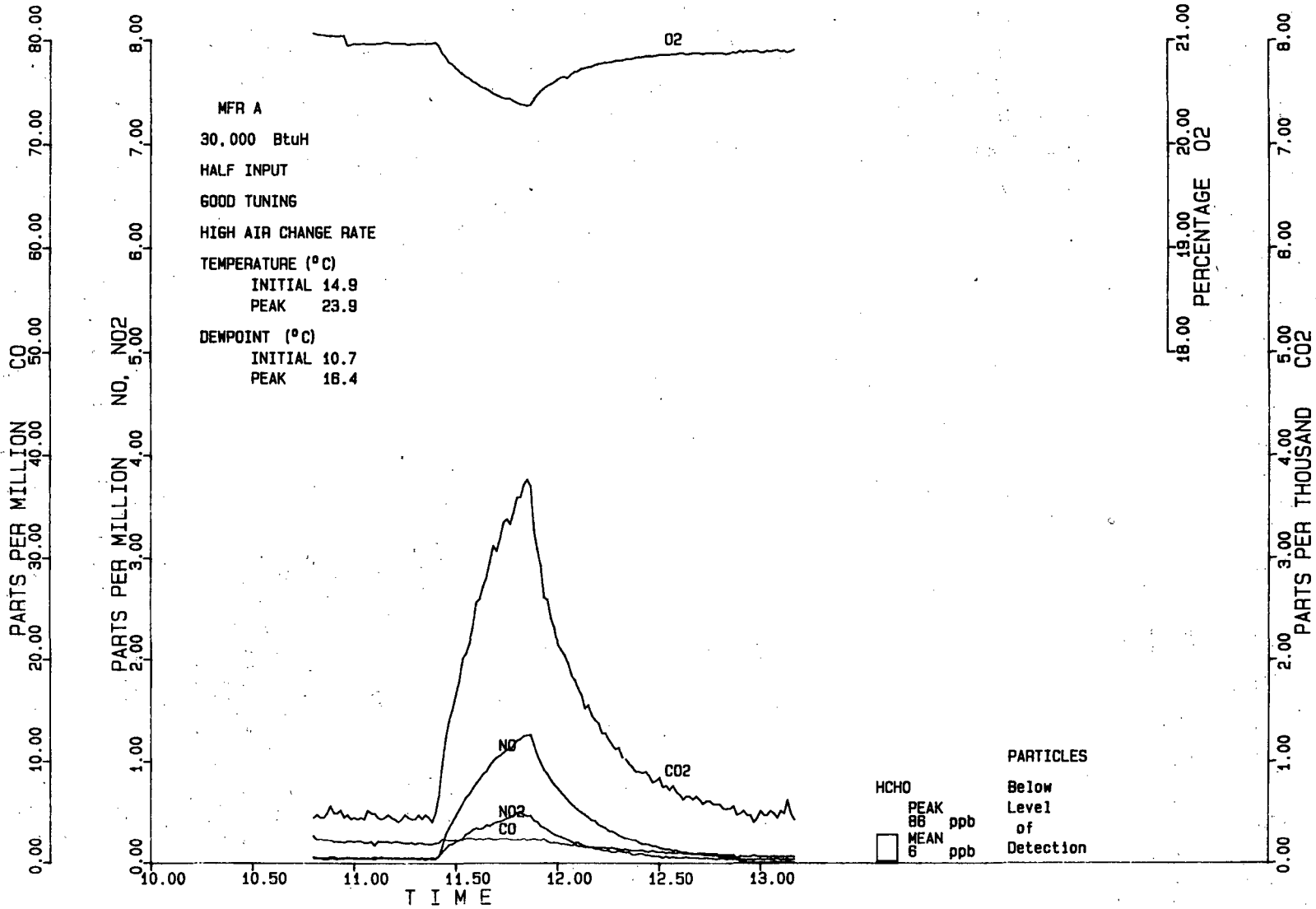

43

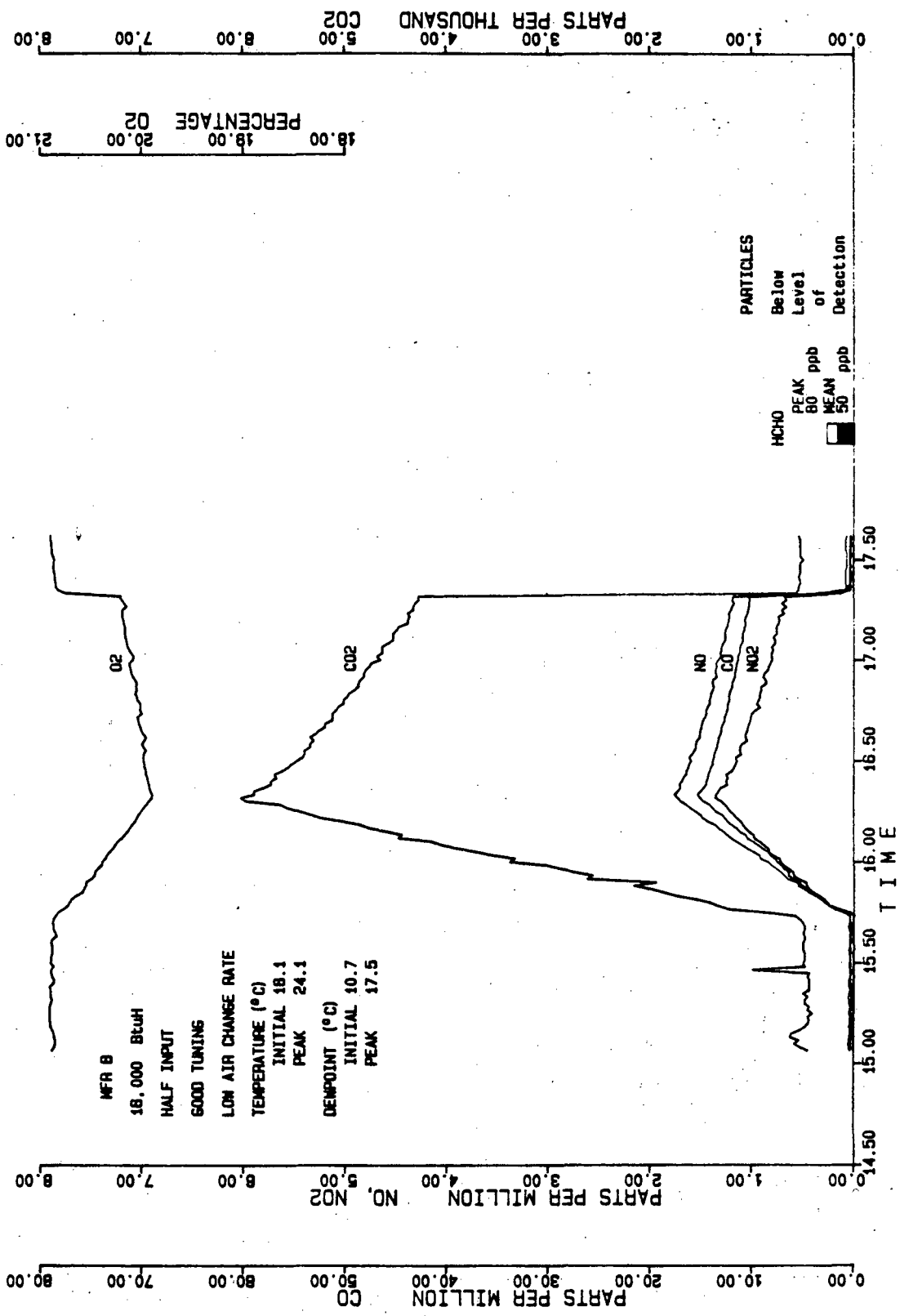

44

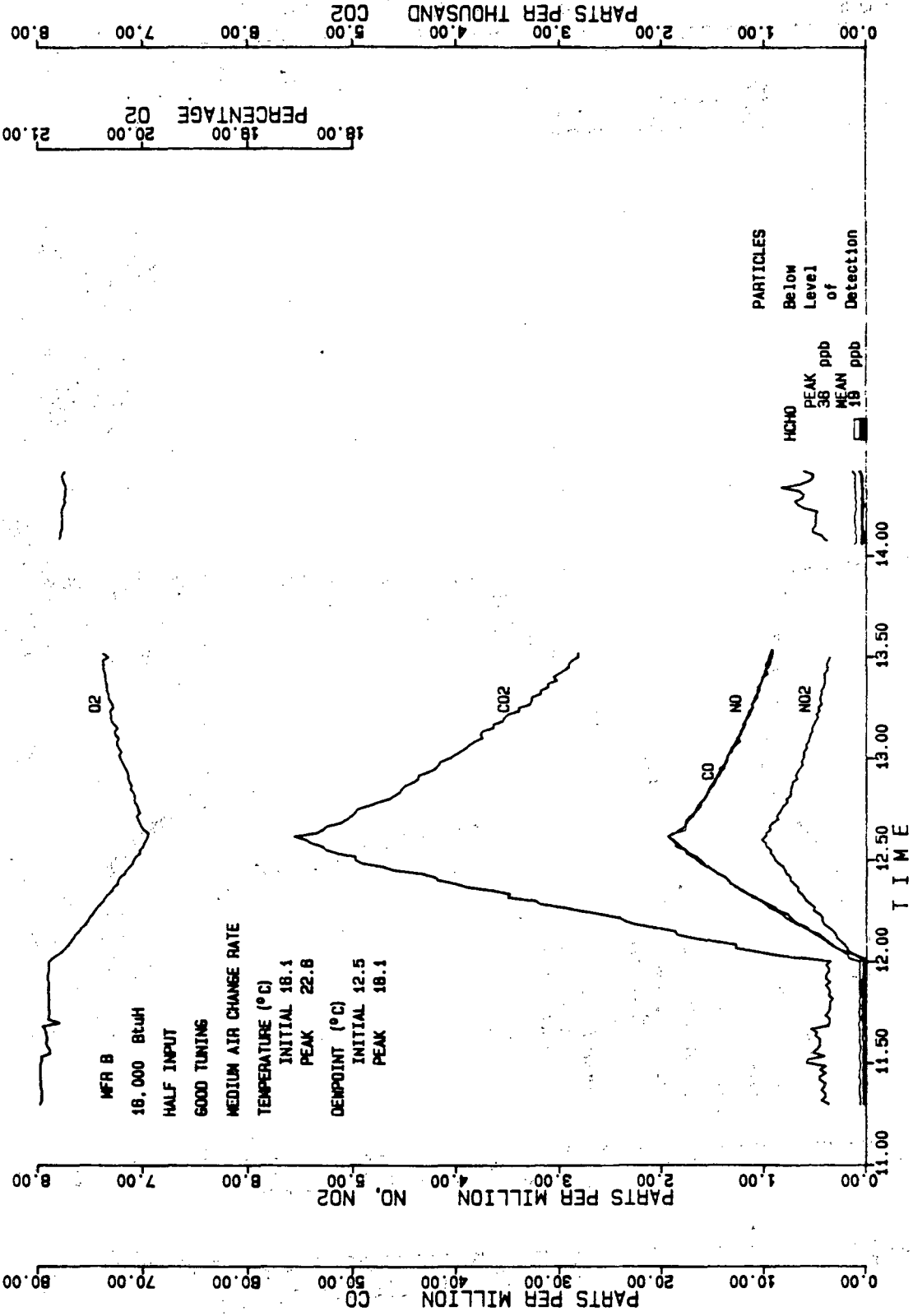

45

-A49-

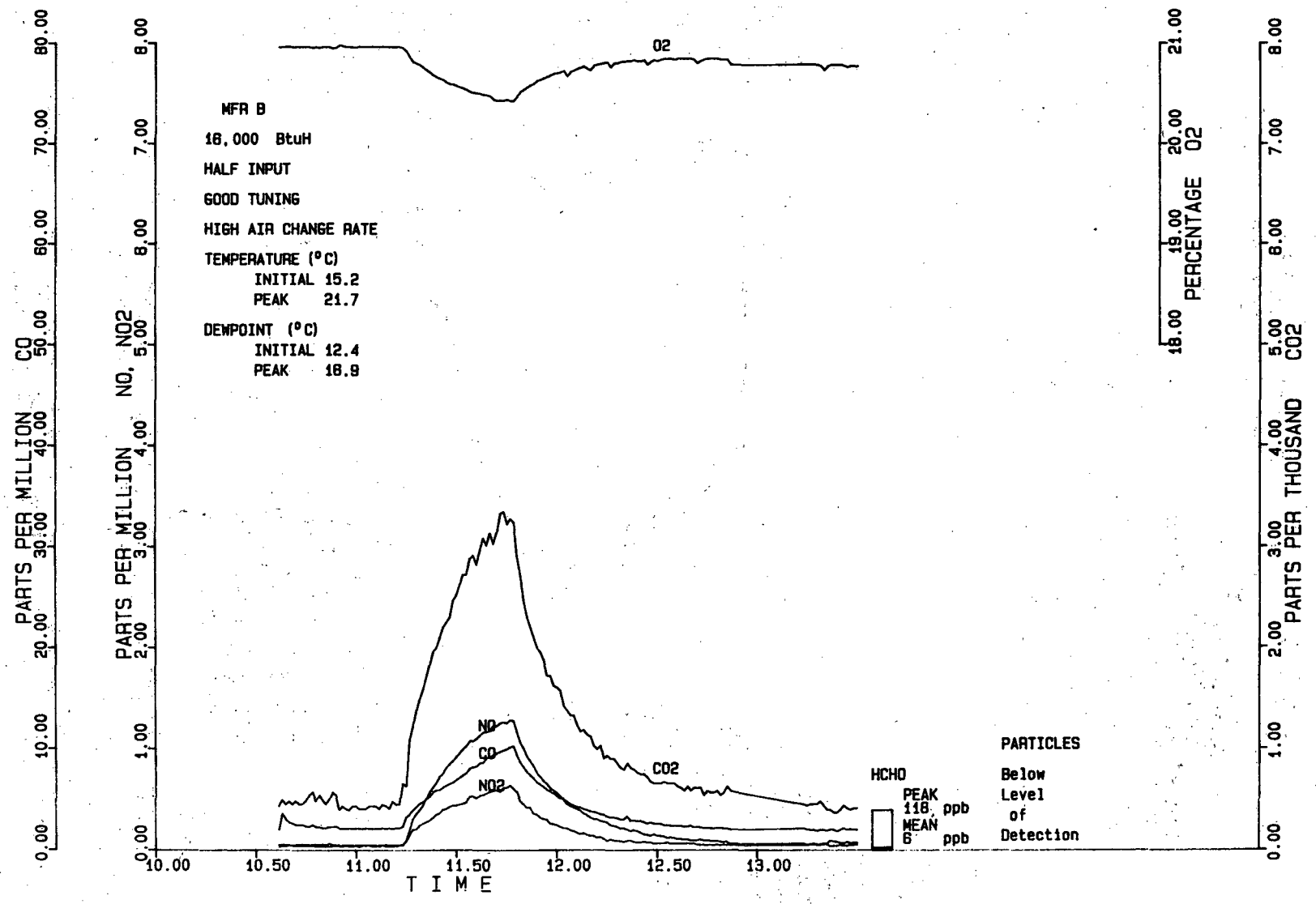

-A50-

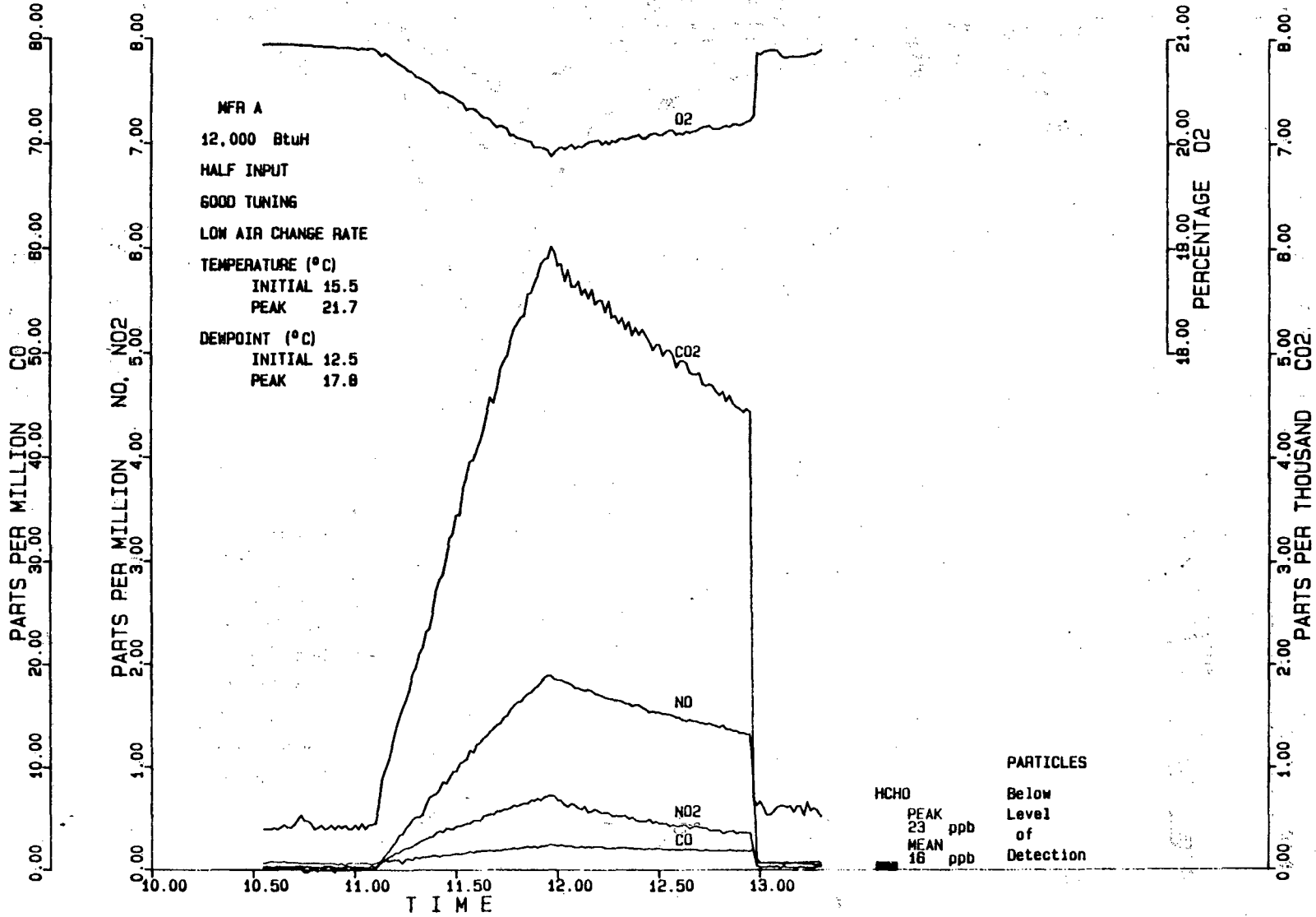

47

-AS1-

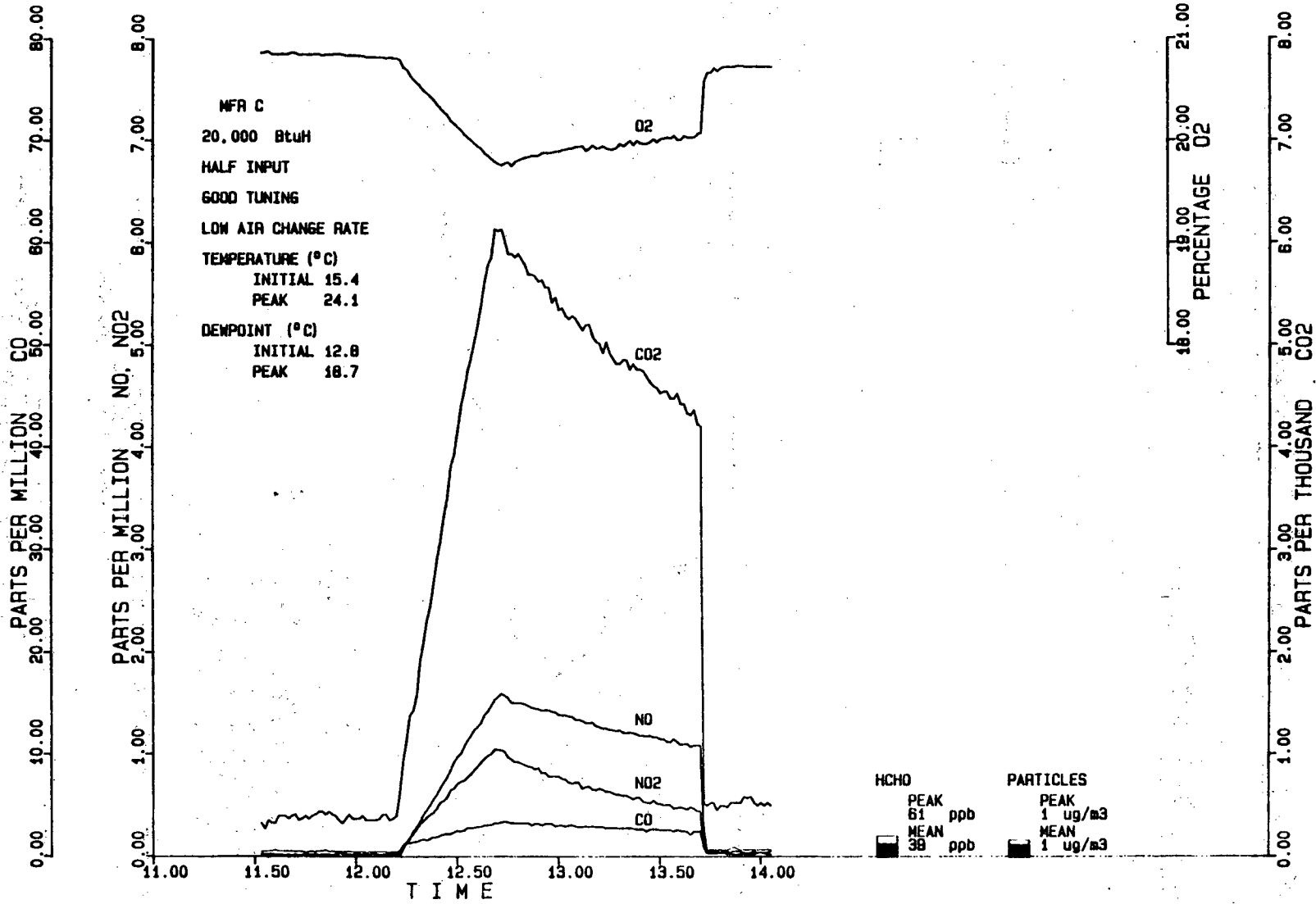

-A52-

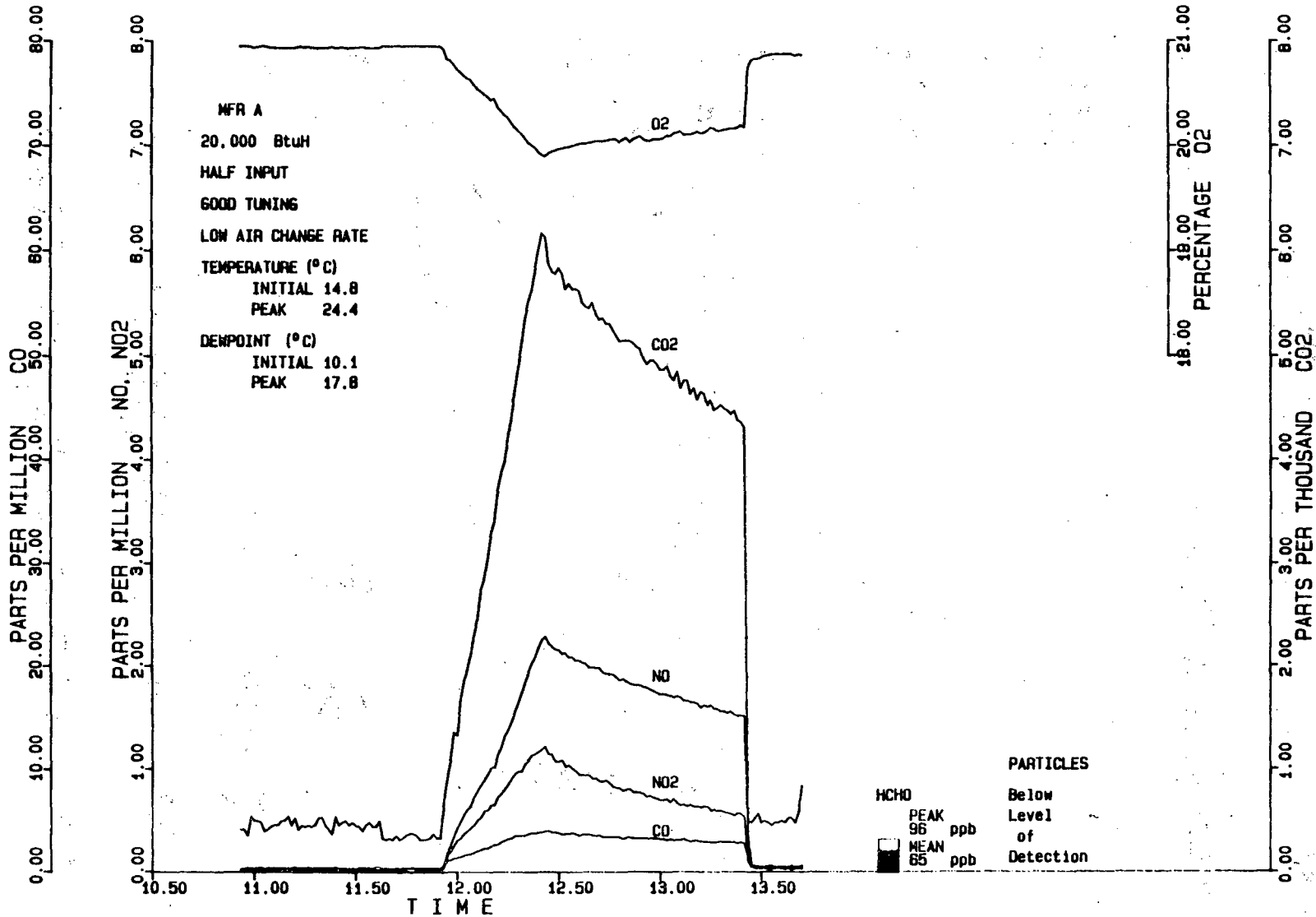

-A53-

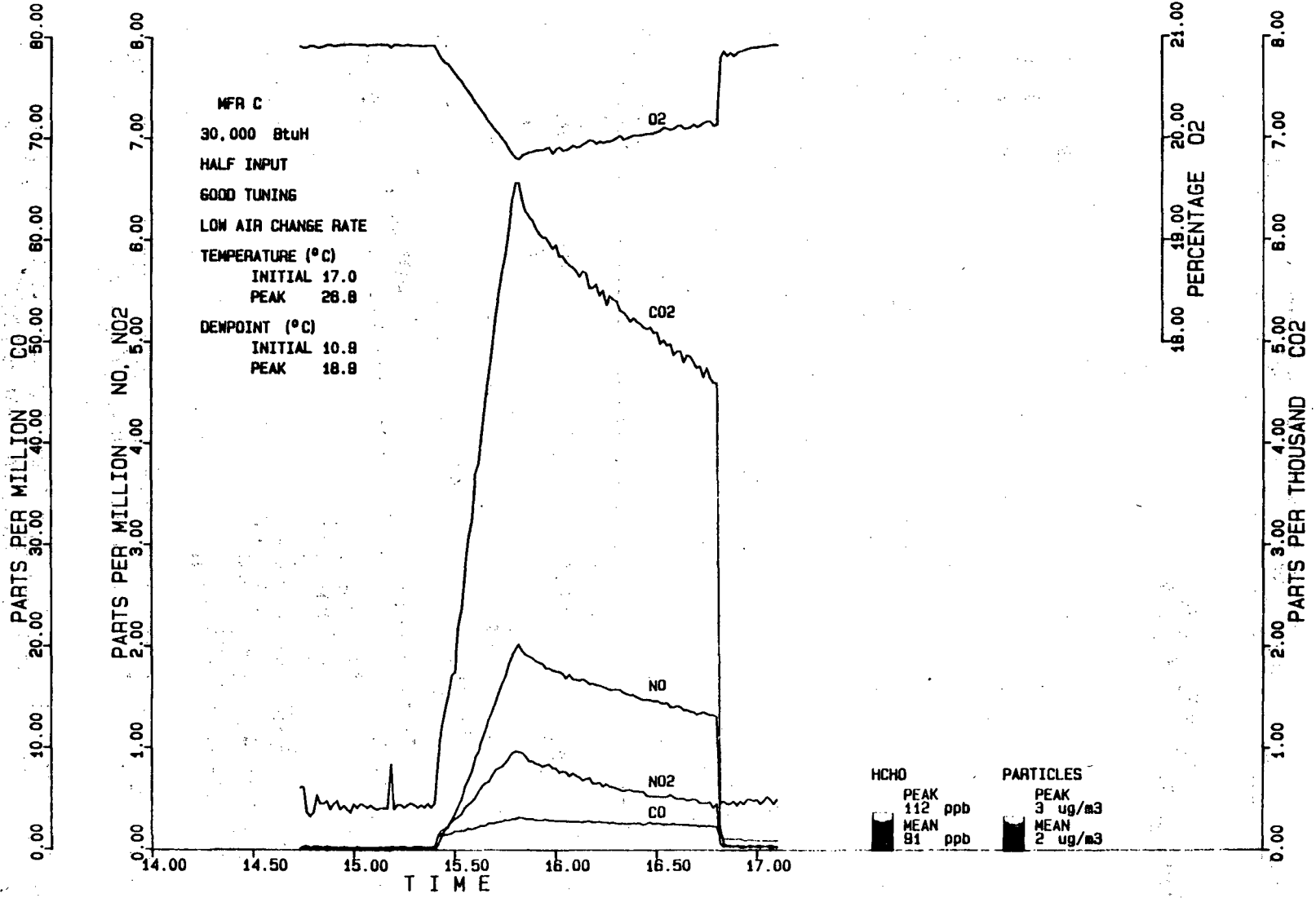

-A54-

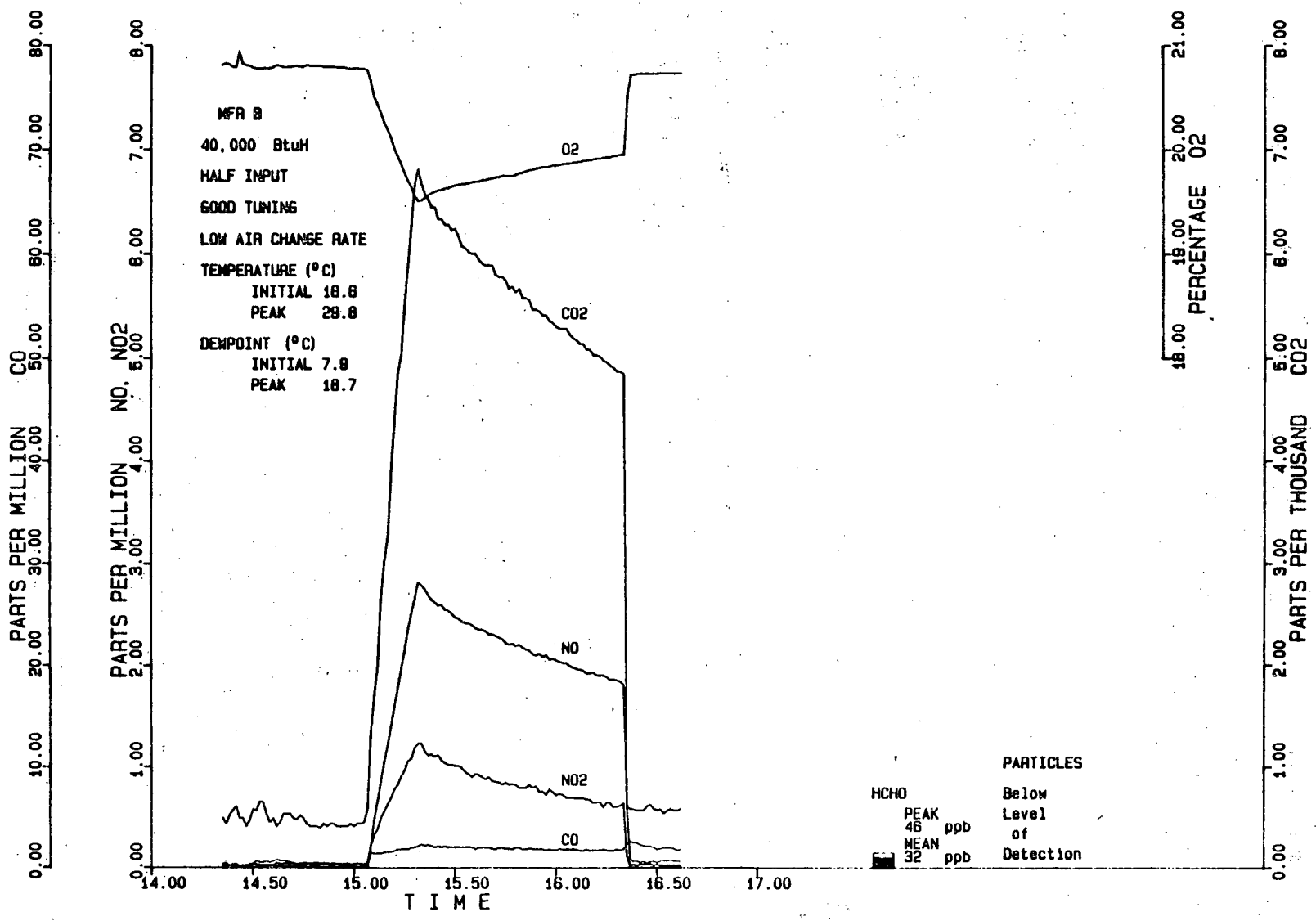

This report was done with support from the Department of Energy. Any conclusions or opinions expressed in this report represent solely those of the author(s) and not necessarily those of The Regents of the University of California, the Lawrence Berkeley Laboratory or the Department of Energy.

Reference to a company or product name does not imply approval or recommendation of the product by the University of California or the U.S. Department of Energy to the exclusion of others that may be suitable.

TECHNICAL INFORMATION DEPARTMENT
LAWRENCE BERKELEY LABORATORY
UNIVERSITY OF CALIFORNIA
BERKELEY, CALIFORNIA 94720