



# Solarflair

## Team Members:

Cristobal Flores	Julissa Rios
Daniel Wong	Charles Sandoval
Inkiad Ahmed	Jeremy Walker
Kimberly Uhls	Matthew Aguilar
Pretan Tabag	Jessica Chin
Leonardo Acosta	Jesse Navarrete
Daniel Gasca	Jumana Alamamreh
Cedric Lim	Daniela Uriostegui
Estin Liu	Laurice Brown
Spencer Kammerman	



# Table of Contents

<b>Table of Contents</b>	<b>2</b>
<b>Overview</b>	<b>3</b>
<b>Goal</b>	<b>5</b>
<b>Objectives</b>	<b>5</b>
<b>Design Specifications</b>	<b>6</b>
<b>System Connectivity</b>	<b>28</b>
<b>Bill of Materials</b>	<b>30</b>
<b>Eco-Friendly Power Supply Bill of Materials</b>	<b>37</b>
<b>Conclusion</b>	<b>38</b>
<b>Works Cited</b>	<b>40</b>



## Overview

The challenge that we designed for was to make a building that combines eco-friendly power and architecture, as well as intelligent systems management that is functional, integrated, environmentally-friendly, and efficient. The building is designed to withstand the seismic activity of Orange County by utilizing a single Friction Pendulum Bearing. The demand of insulation was conquered with respect to natural solutions, resulting in the mass use of smart windows across 77.7% of the surface area. The optimized structure will consider minimal material and cost analysis of environmentally-friendly substance use while maintaining the integrity of the structure through the use of steel-embedded reinforced concrete columns. The unique factor of the Solarflair is the significant savings in lighting and HVAC costs without sacrificing comfortable temperature and brightness. Along with seismic activity, solar energy, energy conservation, and smart technology will be integrated together in order to create one centralized system. This system will accommodate preferences for each employee within the offices as well as provide a safe work environment. Also, an interior delivery system will be used in order to automatically deliver packages directly to the office of the recipient. Overall, the building combines eco-friendly and efficient architectural design, a conveyor belt-driven internal delivery system, a solar and hydro power focused energy generation and conservation system with an intelligent, machine learning-based device management system in order to achieve our goal of an integrated design.



## Goal

Our goal was to make a building that integrates eco-friendly power and architecture, as well as intelligent systems management, that is functional, environmentally-friendly, and efficient.

## Objectives

- Create a smart, energy efficient building where the majority of digital components are synchronized via IoT and ethernet connection
- Determine the hardware and software components necessary for managing the energy consumption of each floor within the building and use a machine learning API to allocate power efficiently
- Use a combination of RFID tags and sensors to maintain a comfortable work environment while keeping checks and failsafes in place to conserve energy
- Design a sample layout of our proposed building, complete with sensors
- Integrate a smart fire prevention network to effectively control and prevent fire while preventing water damage
- Maximize the lighting of the building by having smart windows use up to 80-85% of the walls to produce that given light while simultaneously working as an insulator to keep the building at a set temperature.
  - Summer: keep it cool
  - Winter: keep it warm



# Design Specifications

**Device Controls** The system we designed uses 4 RFID Hub readers, individual RFID tags for each employee's keycard, 53 smoke detectors with one transceiver, 12 motion sensors, 28 light and motion combination sensors, and 29 temperature sensors which all contribute to the real-time management of building lighting, temperature, security, and safety. In addition to our sensors, the Google Machine Learning software we chose, combined with a MySQL database, is also vital to managing the building conditions in a predictive and efficient way. RFID also contributes by allowing employees to input their preferences on a mobile application which are then stored on a cloud-based system as well as their own personal RFID tag. The RFID tag will be programmed to send a specific frequency to a receiver located on the floor the employee is located so the artificial intelligence can accommodate the employee in their work space. The RFID reader, upon detecting the presence of an employee in a room will then signal the rest of our system to activate and adjust the room's conditions to accommodate that employee. Our design focuses on preventing the waste of energy by turning off lights and ceasing HVAC activity on a per-room basis so that no resources are spent on unoccupied space.

Regarding software, the information received by the sensors is analyzed by a learning artificial intelligence which results in making proper adjustments for efficiency as well as detecting patterns. The API will be connected to most digital components in the building and will control climate within the building using sensors measuring temperature, motion, smoke, and light. RFIDs will also be utilized to maximize building security and collect data on employee climate preferences and schedules backed up to an SQL server that includes cloud backup, transparent data encryption, enterprise backup (local data in building sent to cloud), integration with group replication, mySQL router and shell, scalability, authentication, enterprise encryption, firewall, audit, monitoring for maintenance, enterprise manager (system performance), mysql router, workbench, and tech support.



### Projected Energy Usage for Lighting

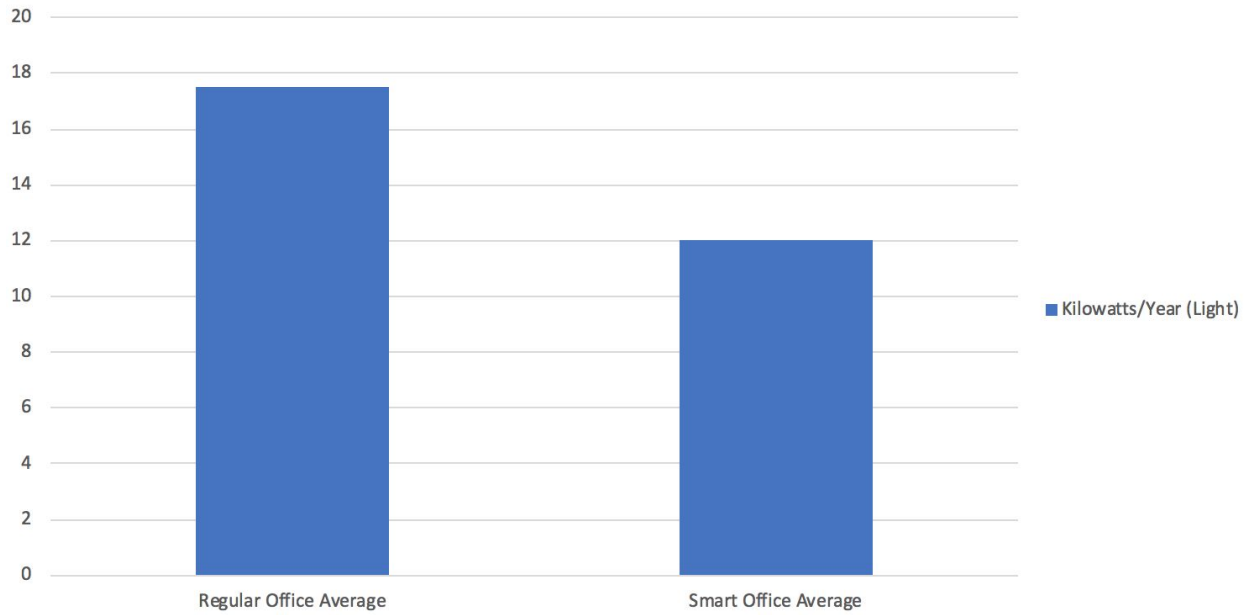

### Projected Energy Usage for HVAC System

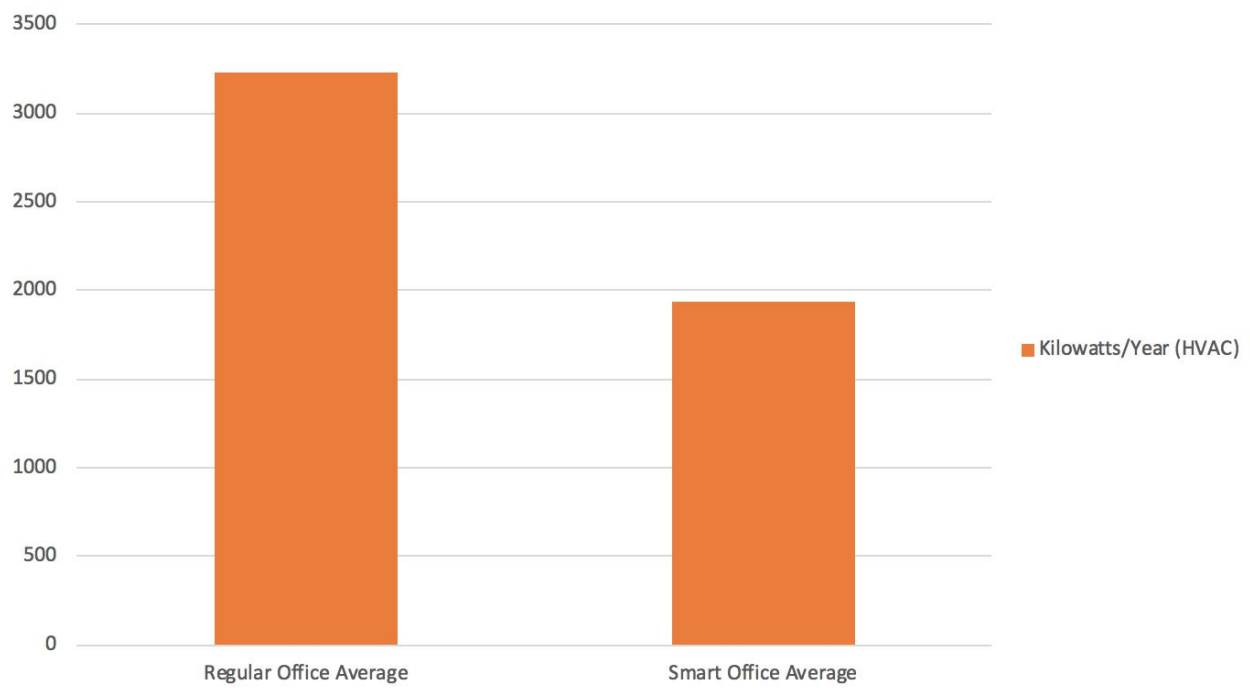



**Zero-Waste:**

**Seismic:** The seismic design meets the requirement of the ASCE 7-10 standard. The shear force ( $V$ ), seismic acceleration, and the coefficients were calculated by using the seismic equations given by the ASCE 7-10. With the Friction Pendulum, the seismic, lateral acceleration on the structure is decreased by approximately 55% giving a total of 0.17g of acceleration saving materials needed to withstand lateral shear forces experienced by the building during seismic activity. To be conservative, the seismic constants used in the calculations counted the Seismic Risk factor as a category IV.

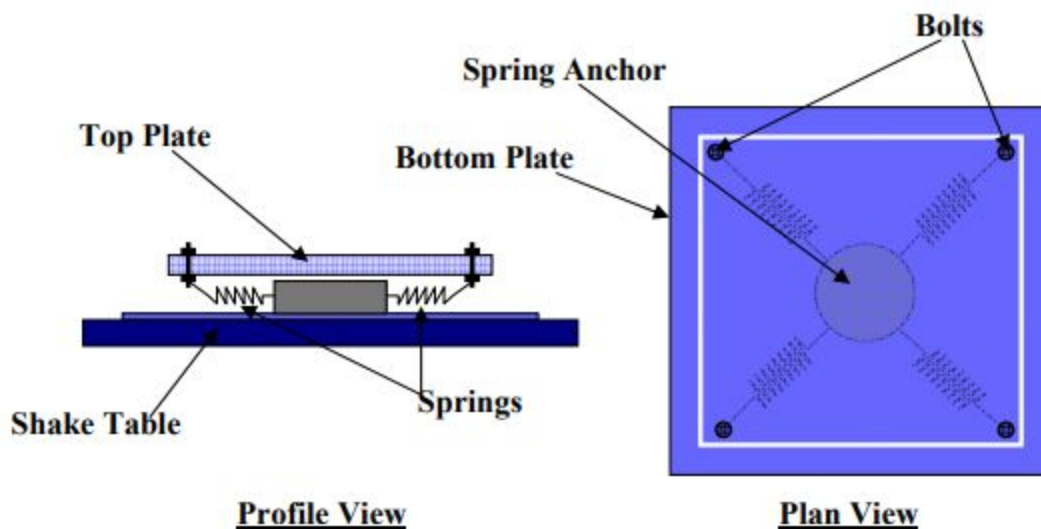

Note: Basic Mechanism of the friction pendulum bearing system. Decreases seismic acceleration by more than 55%, reducing amount of materials needed to withstand horizontal shear forces and ultimately lowers cost of entire building.



**Building Code Reference Document** ASCE 7-10 Standard  
(which utilizes USGS hazard data available in 2008)

**Site Coordinates** 33.64954°N, 117.842°W

**Site Soil Classification** Site Class D – “Stiff Soil”

**Risk Category** IV (e.g. essential facilities)

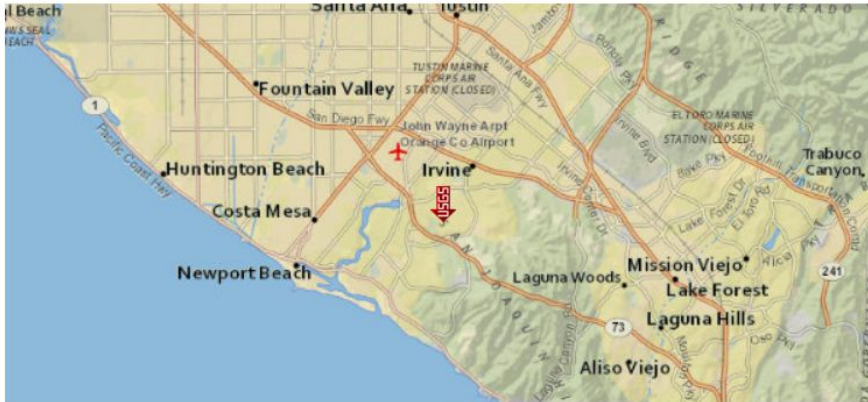

**USGS–Provided Output**

$S_s = 1.583 \text{ g}$        $S_{MS} = 1.583 \text{ g}$        $S_{Ds} = 1.055 \text{ g}$   
 $S_1 = 0.578 \text{ g}$        $S_{M1} = 0.867 \text{ g}$        $S_{D1} = 0.578 \text{ g}$

fc	2500
R	5
$I_e$	1.5
S	1.055 g (gravity)
Cs	0.3165 g (gravity)
V	471711.6 N
Cs(w/Bearing)	0.174075 g (gravity)
V(w/Bearing)	259441.4 g (gravity)

**Design Response Spectrum**

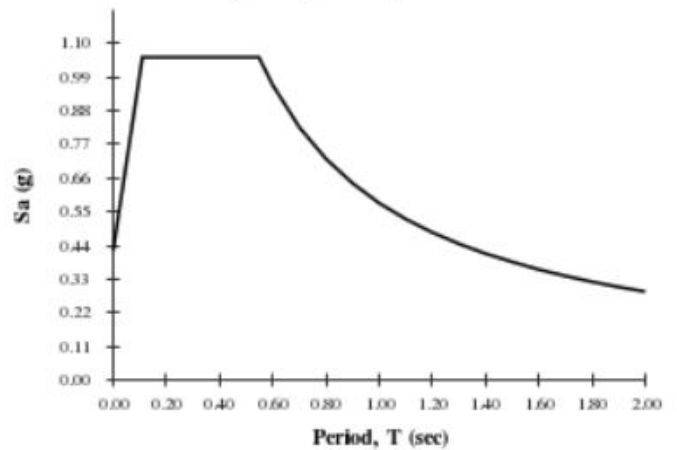

V w/o B	V w/ B
103685.4	57026.97
189140.4	104027.22
323589.6	177974.28
471711.6	259441.38
1088127	598469.85





**Parameters and load:** The parameters of the building was restrained to 2,880  $ft^2$  . The floor designs were created to be 20 ft for the two bottom floors and the two top floors were each 10 ft in height. Each floor had its own unique resistance on how much they would be able to withstand depending on the perimeter and height of each floor. The psf for each was calculated and varied depending on the dead weight and live weight of each floor. The shear area was calculated by using the equations given on the ASCE page along with it's load as seen above. The the redox flow battery will be placed outside with no extension added to the buildings and its just placed outside in the container it was shipped in.

Building:

	Height
4th	10 ft
3rd	10 ft
2nd	20 ft
Lobby	20 ft

Area of Floor	2880 ft
Length	48 ft
Width	60 ft

Loads Used:

	Height	Total load	Wall load	Floor load
4th	10 ft	327600 lb	54000 lb	273600 lb
3rd	10 ft	597600 lb	54000 lb	216000 lb
2nd	20 ft	1022400 lb	108000 lb	316800 lb
Lobby	20 ft	1490400 lb	108000 lb	360000 lb
		3438000 lb		
		1559449.296 kg		

	PSF (live)	V Area	column (in)	Column (ft)	Dead Load	25 psf
4th floor	70 psf	570.2697	11.98045588	0.998371324		
3rd floor	50 psf	1040.2722	16.05358333	1.337798611		
2nd floor	85 psf	1779.7428	21.18741429	1.765617857		
Lobby	100 psf	2594.4138	25.43542941	2.119619118		
		5984.6985				



**Quantities:** Each floor had its volume calculated by the materials we used. Each was separated by the glass, concrete and steel as those are the components. The amount of steel and concrete needed in each floor depended on the load that the floor needed to support. The lobby, for example, require significantly more reinforced concrete surface area than higher floors because it needs to support the shear force of its own weight as well as the weight of the floors above it. After calculating the area needed for shear force, the volume of concrete, and consequently the volume of steel, needed for the project could be estimated. The glass was measured for each floor since each floor had varying heights along with the lobby needing a cut out for a front door.

a) Quantities

Glass	Total used
Lobby	3384 ft <sup>2</sup>
2nd	3480 ft <sup>2</sup>
3rd + 4th	3480 ft <sup>2</sup>
	10344 ft <sup>2</sup>

Volume:

Steel in Column	4.501708417 ft <sup>3</sup>
Steel in Slab	71.97 ft <sup>3</sup>
	76.47170842 ft <sup>3</sup>
Concrete in Colum	180.0683367 ft <sup>3</sup>
Concrete in Slab	7125 ft <sup>3</sup>
	7305.068337 ft <sup>3</sup>

**Pricing:** Each material had its own price per unit and we first needed to determine the volume in order to calculate the total cost. The smart window glass was sold by square feet and also on the long run would save us around \$59,000 per year for using them. The steel was sold by pounds and the concrete by cubic meter. Also, by using the pendulum, that lowered the total cost by 20%.



b) Pricing

Smart Window Glass : 48' x 48' = 2,304 ft<sup>2</sup> → \$ 700 each  
2304 ft<sup>2</sup> / \$700 → \$ 3.29 per sq. ft  
\$3.24 \* 10344 ft<sup>2</sup> → \$ 33,514.56

Total Cost: \$33,515

Savings: \$155,404.80 per year- unoptimized  
\$96,393.60 per year- optimized  
\$59,011.20 per year- our savings

Total Savings by using Smart Windows: \$59,011.20

Bar Reinforcing Steel: \$1.81 per pound

Total Steel: 76.47170842 ft<sup>3</sup> → 37,394.67 lb  
Density of steel: 489 lb/ft<sup>3</sup>

\$1.81 per pound x 220,035.33 = \$67,684.34

Portland Cement Concrete: \$998.39 per cubic meter

Total Concrete: 7305.07 ft<sup>3</sup> → 206.88 m<sup>3</sup>  
\$998.39 per cubic meter → 206.88 m<sup>3</sup> \* \$998.39 = \$206,550.76

Total Cost: \$307,749.66

Total Savings with Bearings:  
It would reduce the total cost by Savings: \$61,549.93 New total cost: \$246,199.73

Total Savings (All combined) : \$120,561.13



### **Interior Delivery Systems:**

The delivery system utilizes five conveyor belt systems: one short horizontal belt for placing the package, one vertical conveyor for moving the package between the floors, and three long horizontal belts on each floor that wrap around the office buildings. To power the conveyor belts, eight brushless DC motors are used to power them: one for the first short belt, one for the vertical, and two on each floor for the horizontal belts.

Both the conveyor belts and the framing will be made of aluminum alloy 6061 which is cheap and also quite durable for our purposes. For one floor, the total weight of the conveyor belt is calculated from its density. With the weight and the desired speed, the total kinetic energy can be computed the following way:

$$E_K = \frac{1}{2}mv^2 = \frac{1}{2} \cdot 420 \cdot 0.5^2 \approx 60J$$

Power can be estimated from the time the system takes to accelerate up to that speed plus some losses so the final power chosen for the motors has been 150W, however the motor chosen is more powerful, at a 1hp (180W).

For the motors lifting the packages from the lobby to the offices, the assumption made has been similar, since the weight of conveyor going up is the same as the weight going down, the same power for the motor has been specified.

The system consists of 7 motors, two for each floor (on for each direction) and a last one that is in charge of lifting the packages from the lobby.

Assuming a workday of 10 hours and the motors working at full power the whole time, the total energy consumed by the design in a day is roughly 13KW.

The material used for the horizontal conveyor belt is aluminum 6061, its validity for the job has been proven using ANSYS, for a weight of 100lbs, the stresses on the body look like in the following figure:



**A: Static Structural**  
Total Deformation  
Type: Total Deformation  
Unit: m  
Time: 1  
5/27/2018 8:31 PM

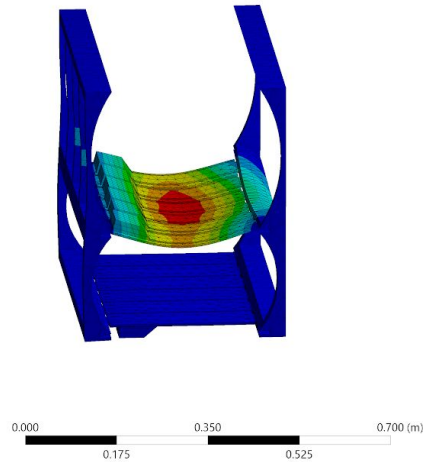
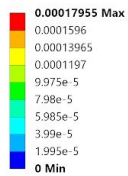

*Deformation Simulation for a horizontal conveyor belt. Factor of safety ~ 8*

The maximum deformation suffered by the structure is safe enough, so the material chosen is able to do the job.

However for the lifting conveyor belt, based on some simulations is able to lift at most 50 lbs per each slot, the deformation obtained in the simulations is the following:

**B: Static Structural**  
Total Deformation  
Type: Total Deformation  
Unit: m  
Time: 1  
5/27/2018 8:52 PM

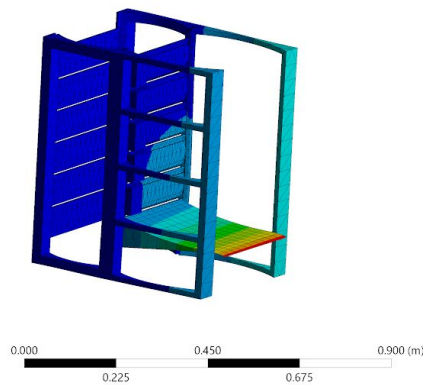
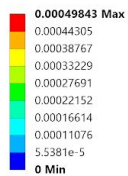



*Deforming Simulation for a vertical conveyor belt. Factor of safety ~ 3.5*

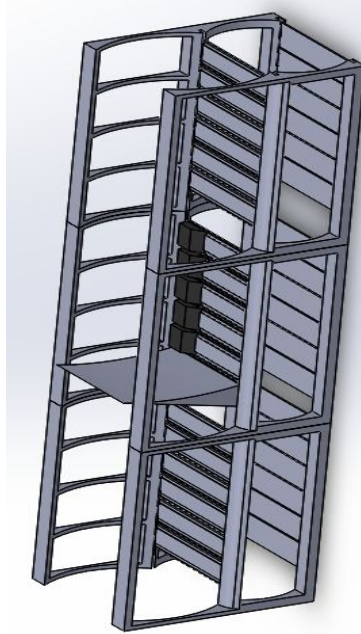

*This is the vertical conveyor belt that delivers the package to the desired floor. There are shoe sorters that push the package to the horizontal conveyor belt.*

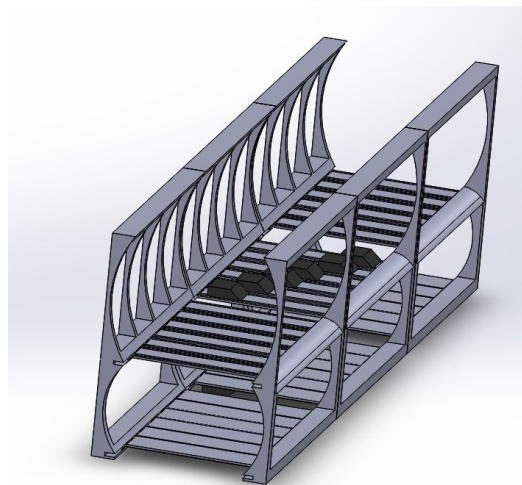

*The image above is that of the horizontal conveyor belt which receives the package from the vertical belt and then delivers it to its specified office with the shoe sorters. It is located just underneath the ceiling.*



### **Eco-Friendly Power Supply:**

The Solar Energy group of the Eco-Friendly Power Supply committee used 60 SolarWorld solar panels and 60 DualSun solar thermal panels are that are placed on the roof. The DualSun solar panels heat water which will travel through pipes distributed throughout the building. To heat the building in the case that the water is not hot enough, it will be run through a boiler to heat the water to 99 degrees celsius. 48g H<sub>2</sub>O/m<sup>3</sup> can be used to raise the temperature by 5 degrees celsius. This assumes that the water is in direct contact with the air, but determines that the idea is completely feasible. To cool the building, water will be run through the ground and pumped back up through copper pipes. On the sides of the building, 250 solar tiles will be placed on a solar tracking mechanism to allow for maximum sun exposure. At 75% efficiency, 60 thermal panels should produce 30kW. In conjunction with solar panels at 25% efficiency, 3.6kW should be produced. With 1,000 solar tiles, an additional 3.96kW should be produced. A grand total of 7.56kW will be produced consistently. The following diagram shows a schematic of the placement of the solar panels.

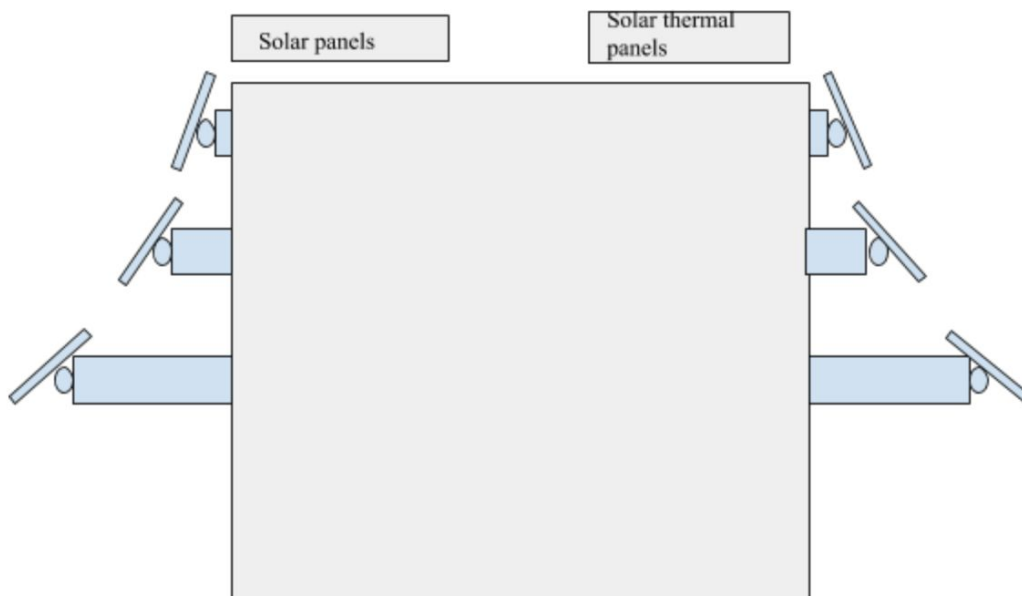

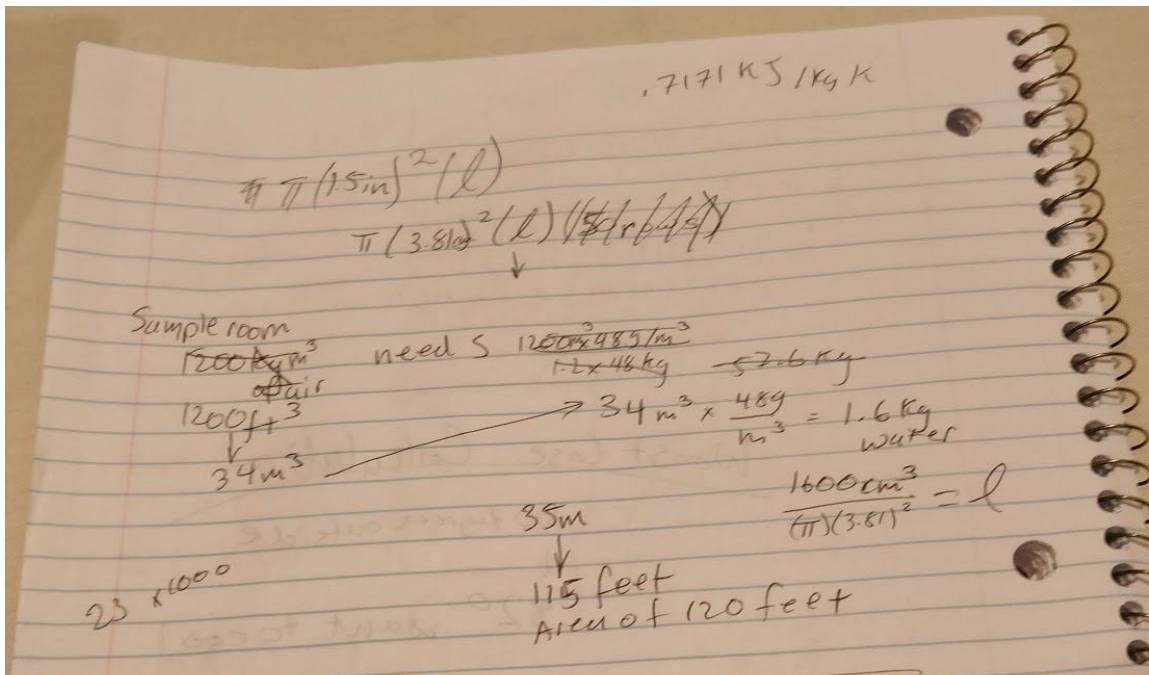
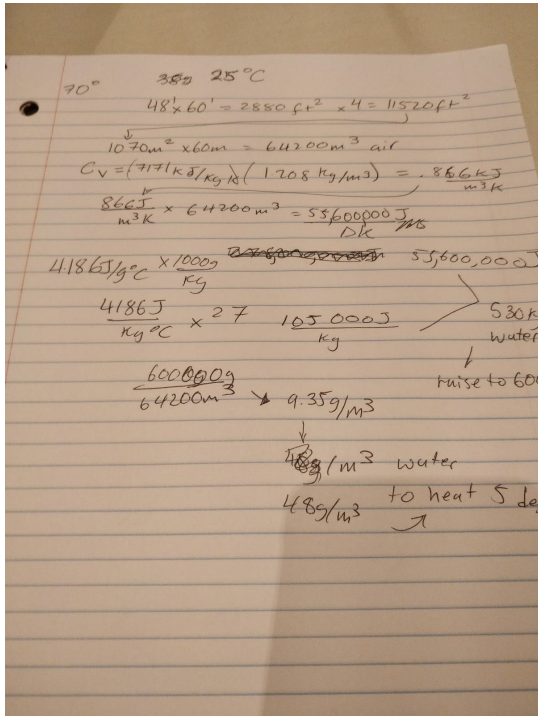

(These are calculations for the piping that is needed in the building.)





# Design Breakdown

## Zero-Waste:

AutoCAD and Sketchup were used to generate the layout and the exterior design.. The images below represent the floors 2, 3 and 4, and the base floor lobby. The non-structural wall component is reserved for the placement of windows. The columns are filled with solar panels along with the roof.

/

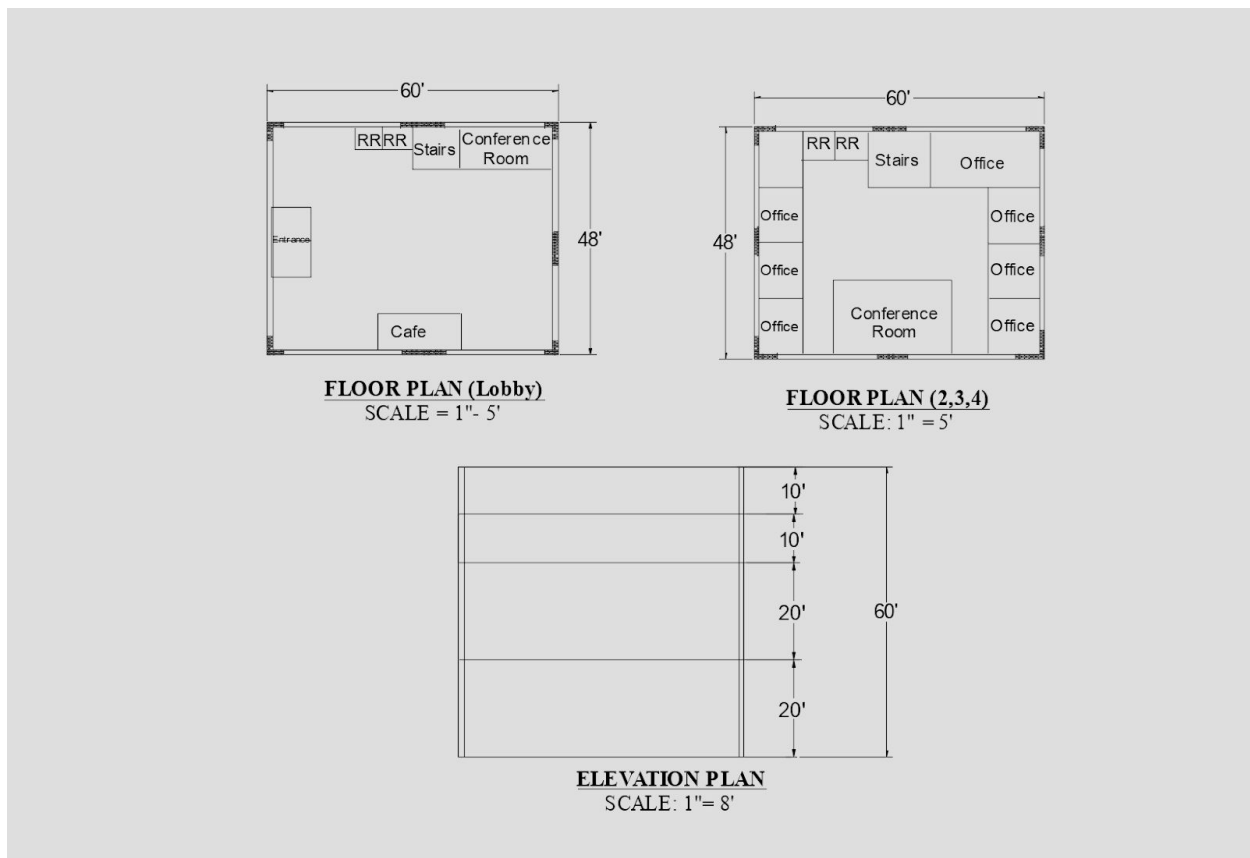

For the upper floors, they utilize less material. The loads are less and each floor was accounted for the same deadweight. Steel Reinforcements are needed because concrete, although strong, is only effective when in compression. Steel adds tensile strength to concrete allowing it to withstand higher bending moments and engineers to see deformation over time as opposed to brittle, concrete without reinforcement which can give away suddenly with little to no warning.

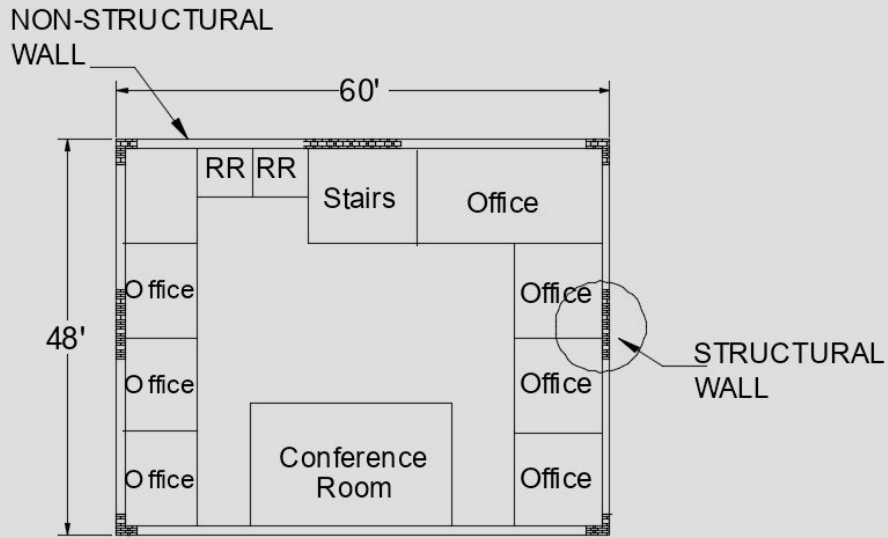

**FLOOR PLAN (All)**  
SCALE: 1" = 5'

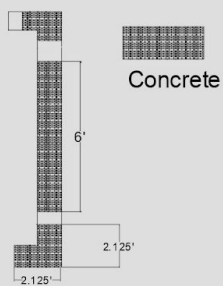

**WALL THICKNESS (FIRST FLOOR)**  
FIRSCALE: 1" = 1

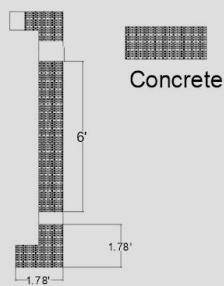

**WALL THICKNESS (2nd FLOOR)**  
FIRSCALE: 1" = 1

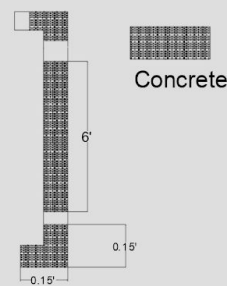

**WALL THICKNESS (3rd FLOOR)**  
FIRSCALE: 1" = 1

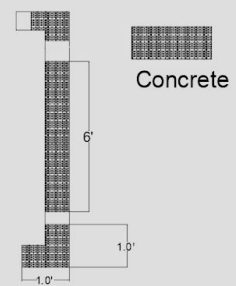

**WALL THICKNESS (4th FLOOR)**  
FIRSCALE: 1" = 1

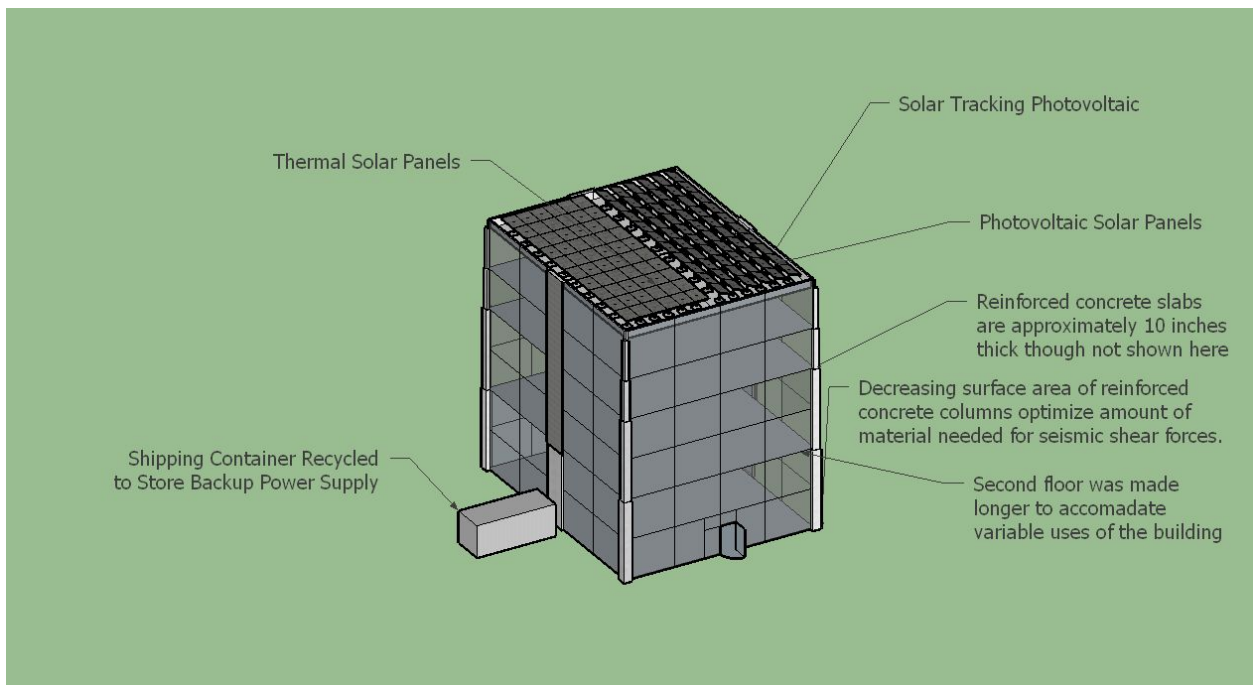
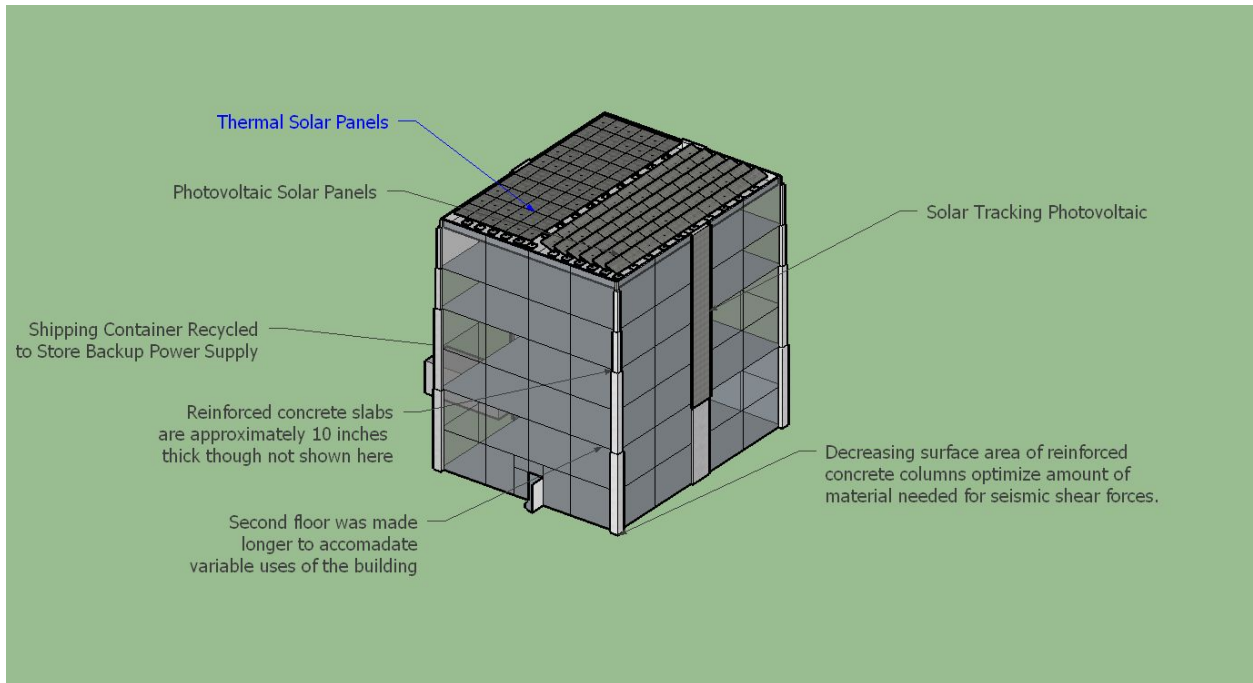

Note: Not to scale. Simplified version provided for basic overview.



The device control system is designed to take input from various sensors located throughout the building and use the data that they read to make decisions about building conditions and management using a machine learning algorithm. We chose light sensors that would detect the amount of sunlight both inside and outside of the building to manage our interior lighting and to calculate the optimal position of the external solar panels for energy collection. RFID tags are used to track employee locations for both security and accessibility purposes. Profiles stored on the RFID tags allow for specific rooms to be customized to the preferences of the occupants. Motion sensors are used in conjunction to these RFID tags to make sure no rooms are being adjusted when unoccupied as well as to detect possible unauthorized personnel inside of the buildings. Temperature is measured by thermosensors, and to meet a target temperature, the machine learning software will adjust the hydro-HVAC system. Fire safety is accounted for via temp and heat-sensing smoke detectors that will alert our software system as to where exactly a fire is located so that sprinklers can be activated locally and no unnecessary damage is caused. Smart piping sensors alert the software system to the status of the hydro-cooling system and the building's general piping.

This design's smart pathways manage the building's lighting, temperature, safety, security, preventative maintenance and power generation. The illumination of the building will be adjusted based on employee RFID profile preferences and will also be either decreased or increased according to the amount of sunlight outside, allowing us to rely more on natural lighting and cutting down on overall lighting costs. The lights are also disabled in rooms without detected RFID presence so that no energy is wasted on unoccupied rooms. The HVAC system is controlled similarly, with employee preferences affecting specific rooms for customizability, while the general building temperature is monitored by out thermal sensors so that an optimal temperature can be maintained at all times. Fire safety uses the smoke detectors to locate exactly where a fire is and dispatch sprinklers so that only the specific area with the fire is doused. The preventive maintenance system in the smart piping systems will constantly monitor in order to detect possible leaks or flow issues and report this data into the database. Finally, security is managed with the RFID system, which calls the front door to unlock when employees approach and also allows employees to be tracked location-wise around the building.



Failsafes for this system are additionally implemented. Such failsafes include the ability for the controller to ping the AI to verify that all systems are online, if it does not receive a response after a preset amount of pings, the controller will revert to a backup system allowing for the fire system in particular to still be active.

The machine learning algorithm uses both a database of the employee preferences and data taken from sensors in order to improve the overall energy efficiency of the building. By utilizing unsupervised learning and k-means clustering with a neural network implementation, the algorithm will be able to create perceptrons based on conditions taken from the state of the office and provided data to come to a calculated prediction of how to best maintain optimal energy usage.

### **Eco-Friendly Power Supply:**

#### **The Ball and Socket Mechanism**



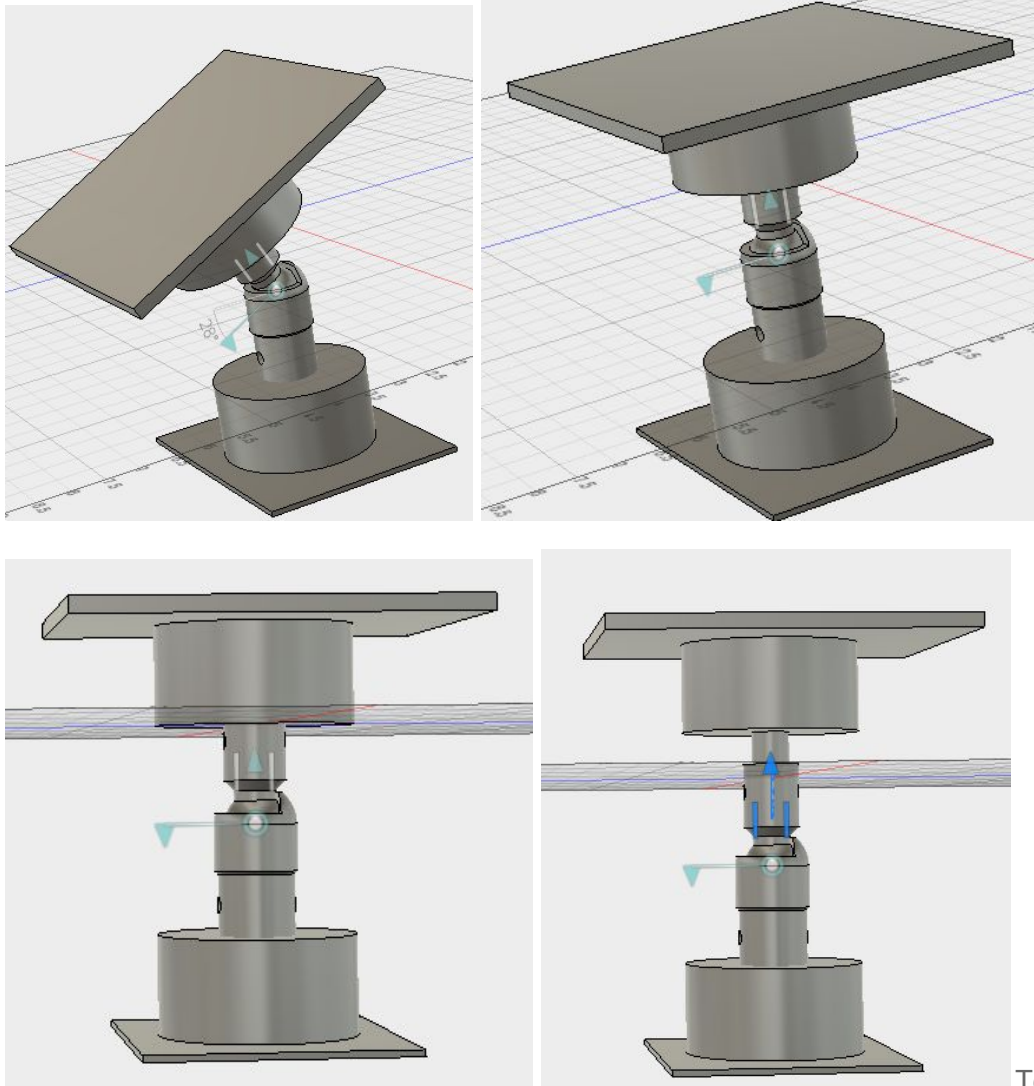

Tesla solar tiles

are connected to the ball and socket device

- Integrating this mechanism with the device controls system, the solar panels can track the sun and pivot according to the sun's position
- Theta Range:  $0^{\circ}$  to  $30^{\circ}$ ; able to support a torque of 2930 in/lb
- Vertical Movement controlled using a linear actuator controlled via Raspberry Pi able to provide 250 psi
- 275 tiles will be placed on each side of the building, covering only a total of 10% of the surface area
- Each tile gives 3.6 W of energy, producing a total of 3690 W



- Tesla's solar tiles can withstand the impact of a 2" hailstone at 100 mph, making them much sturdier in comparison to normal tiles
- The ball and socket device allows for maximum sun exposure as the tiles move according to the sun's position
- An additional benefit is providing shade to the building, lowering the effect of heat.

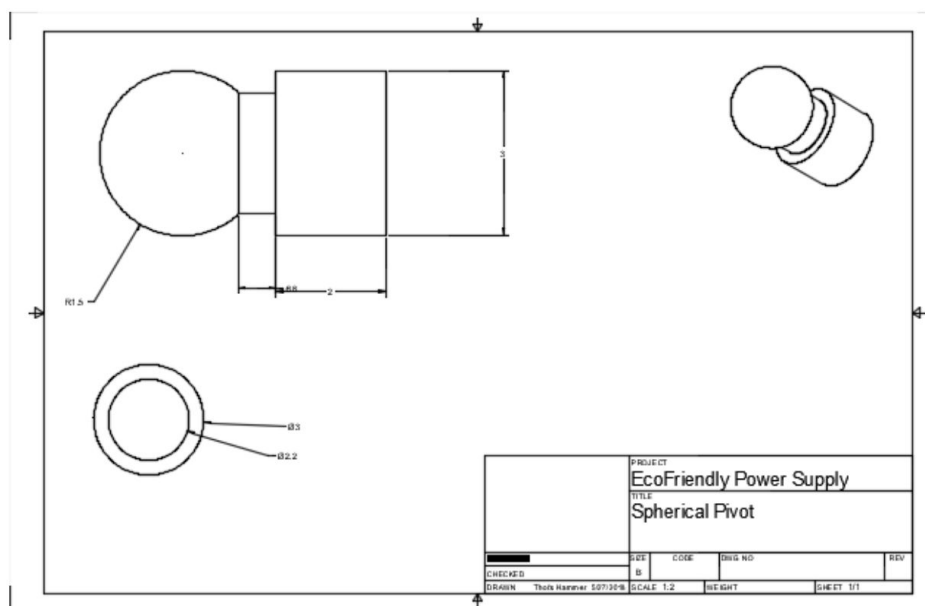
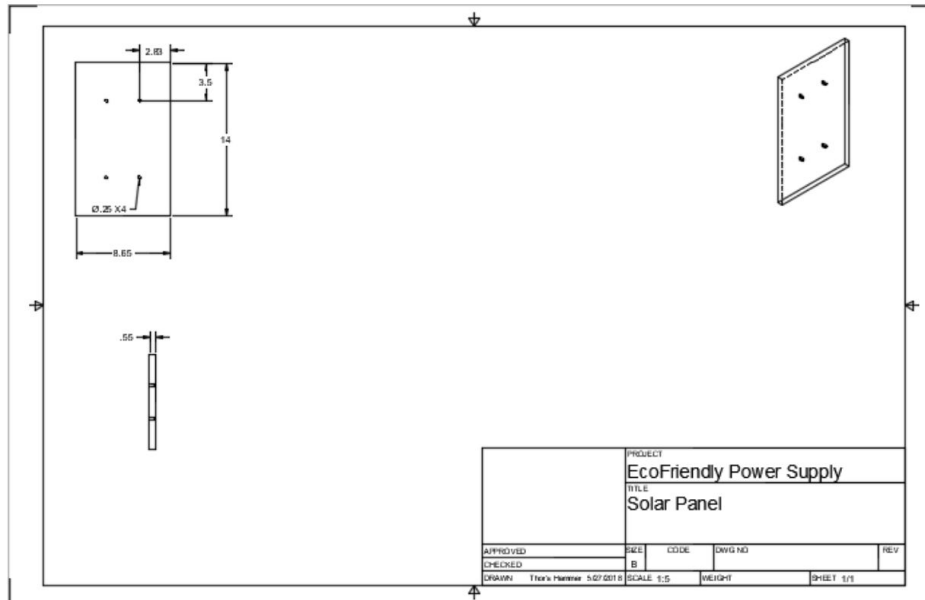

## Solar Thermal Energy



- The solar thermal panels will heat tubes containing water up to high temperatures
- The heated water is passed through the pipes to either a heating or cooling system
- The water is then recycled and redistributed using pumps

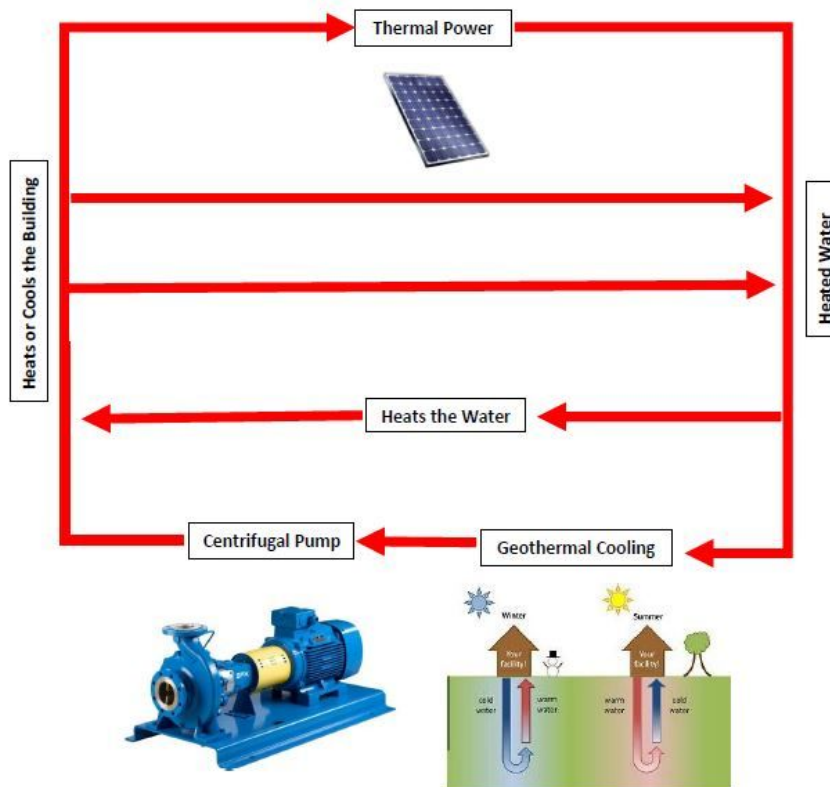

## Heating

- Hot water runs through copper pipes and through the ceiling to help increase the temperature of the air surrounding it.
- To raise the temperature of 1 m<sup>3</sup> of air by 7 °C, 26.2 g can be used theoretically
- 100 rows of pipes must be situated like Fig. 5, which will handle ~30 kg of water. 30 kg > 26.2 kg, which is sufficient to heat the building by 7 °C
- This system allows for water to be simply heated by the sun and used throughout the building



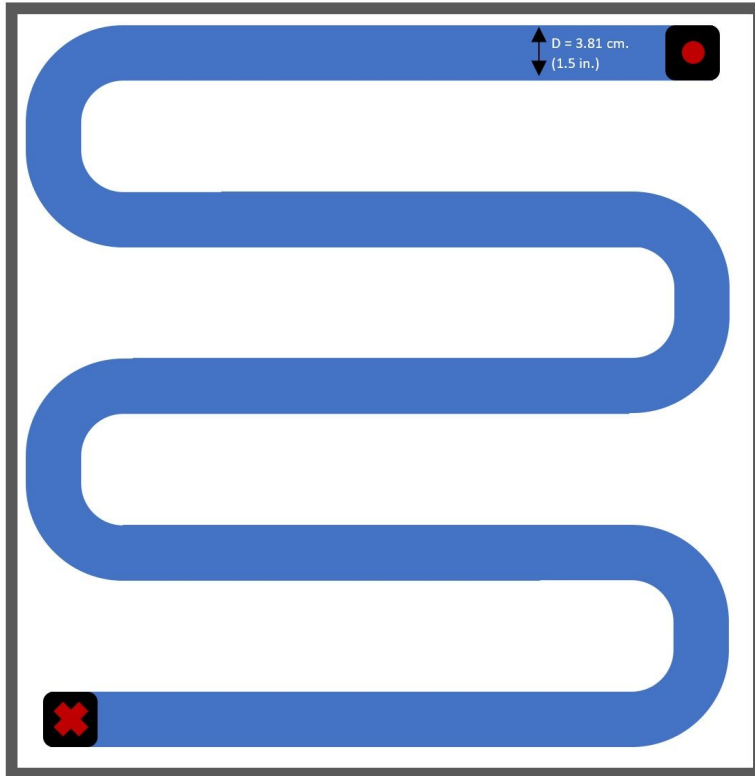

### Cooling

- Copper pipes will be run on the side of the building and into the ground to allow for geothermal cooling

### Energy storage

- Rechargeable Lithium Ion Batteries
- Batteries store a total of 96 kW hrs
  - Two 12-hour days worth of electricity



### **Interior Delivery System:**

The design of the conveyor belts utilizes  $\frac{1}{4}$  hp DC brushless motors to power the movement of aluminum belts at a certain speed. As the package moves along the system of conveyor belts, sliding shoes check for the location that is desired of where the package should be delivered and send pushes it onto the floor or room when the location is correct. By utilizing energy calculations in the “Design Specifications” sections, we calculated the approximate minimum power of the motors needed.

Number of Shoes vs. Max Wait Time

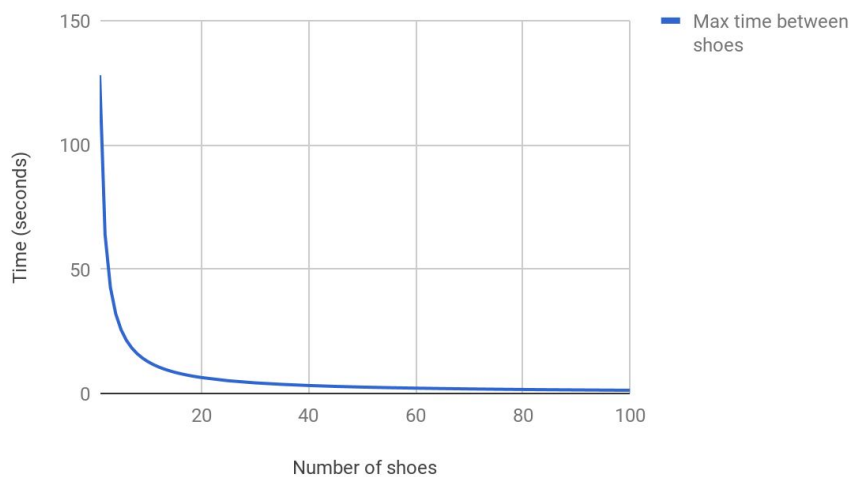

### *Number of Shoes vs. Max Wait Time*

Based on the optimization of comparing the time saved compared to the number of sliding shoes, we have decided that the optimal number of shoes before the time saved is not worth the price is at approximately 90 shoes, where further increasing the number of shoes results in negligible increases in the amount of time saved. As such, we will be utilizing 90 shoes per floor of conveyor belts, and the remaining 30 shoes will be utilized in the vertical conveyor to push them onto the horizontal conveyor. In addition, the minimal amount of purchased sliding shoes before bulk price is reduced is at a quantity of 300, which creates the perfect scenario for both optimizing the time and the price.



## System Connectivity

The data flow of the device management system utilizes a MySQL database as a reference point for every command that might be given in our building. The sensors constantly feed the current conditions of the building into the database so that the information can be called upon as historical data. Then the machine learning API, provided by Google, uses the building condition data within the database to formulate predictions to optimize energy usage. Finally, the predictions are sent to the EagleAX controller, which then orders the lighting, HVAC, fire prevention, and security systems of the building to adjust their settings in order to optimize energy efficiency and employee comfort, and keep the building safe. The machine learning program also inputs the commands it issues to the controller and information back into the database so that they can be stored and used in the future to accelerate the machine learning process and improve the efficiency of the energy system.

In terms of hardware for device management, the sensors are critical to every decision being made by the smart building. The conditions of the building, including temperature, light intensity, and number of people in the building are recorded by the various sensors. This data is transmitted to the database and controller through two main types of connection, Ethernet and wireless. Every sensor uses Ethernet connection with the exception of the RFID receivers and the smoke alarms which transmit their signals to their specific transceiver; this translates to a robust, swift, and efficient connection established between the data collection and storage components of the smart building.

The building as a whole uses the design of the device management system to interact with the other core systems in the building. The delivery system is managed by a single ethernet capable PLC (Programmable Logic Controller) that will direct the package along the conveyor belt system. Our machine learning software will work with external light sensors to find the optimal position of the solar panels used by the eco-friendly power team at all times of the day. Smart pipe sensors monitor the condition of the eco team's hydro cooling system to assure it is working correctly and efficiently at all times, and that it can maintain temperature throughout the building.



All systems are integrated seamlessly to work with the vast surface area of the Efficantis. Use of natural light is not compromised by the lateral solar panels, and floors are lined with wiring to integrate delivery and AI. The tall height of lobby and gallery allow for control rooms to be concise and leaves plentiful space for the delivery system to take place. Office floor walls are not floor to ceiling in order to allow delivery systems to optimize without hindrance.

### **Eco-Friendly Power Supply:**

We start with a hybrid solar *DualSun* panel that simultaneously produces electricity and hot water on the rooftop. The thermal panel will distribute hot water throughout the building using copper pipes. These pipes will run downstream towards the bottom of the building. At the bottom, if the temperature in the building needs to be increased, the stream of hot water will run through a boiling system in the basement. If the temperature of the building needs to be lowered, the water will run underground and dissipate heat. Whether the water goes through the boiling or cooling system is determined by a *Temperature Probe*. In either scenario the water will pass through a centrifugal pump where it will travel upstream in the building with about 20-30 psi. The water, either hot or cold, will be redistributed through pipes in the building and back into the thermal panels as well. The solar panel system on the roof will not be able to produce enough electrical energy throughout the building so an additional 1100 photovoltaic solar tiles will be attached on the sides of the building using a modified mounting system that we will call the *sunflour*. This mounting system includes a ball and socket mechanism that allows the panels to pivot according to the sun's position allowing for maximum sun exposure. These solar panels are Tesla solar panels that have a tracking feature that will move with the direction of the sun.

### **Interior Delivery System:**

After choosing a floor level and room to send the package to via a controls system, the box is placed on a short conveyor belt on the first floor. This conveyor belt leads to a vertical conveyor belt that has attached plates that can carry the box to any of the three floors. The vertical pulley system has sliding shoe sorters that are connected wirelessly to the control system. These sorters will push the package to a separate conveyor if the desired room level is reached. Once the



desired floor is reached, the box will be pushed onto the room's conveyor belt system. Located on each floor is a conveyor belt system that runs just beneath the ceiling, supported by an aluminum alloy frame. Within this frame is a conveyor belt system that also utilizes the sliding shoe sorters, and runs just around the outside of the office rooms. Once the desired room is reached, the sliding shoes will push the package through a trapdoor near the top of the rooms alongside the wall that contains the door. The trapdoor allows the box to slide down a short distance onto a cushioned spot where the package will land.

## Bill of Materials

### Bill of Materials - Interior Delivery System

<i>Item</i>	<i>Description</i>	<i>Link</i>	<i>Manufacturer</i>	<i>Price per unit</i>	<i>Quantity</i>	<i>Total price</i>
DC Motors	<i>Rotates the conveyor belts</i>	<a href="#">Link</a>	<i>ATO</i>	<i>\$445.47</i>	<i>8</i>	<i>\$3563.76</i>
Conveyor Belts	<i>Makes up the belt of the</i>	<a href="#">Link</a>	<i>Shanghai Hengtie Steel Trading Co., Ltd.</i>	<i>\$0.95/lb</i>	<i>3195 lb</i>	<i>\$3,035.25</i>
Frame and supports	<i>Makes up the support</i>	<a href="#">Link</a>	<i>Shanghai Hengtie Steel</i>	<i>\$0.95/lb</i>	<i>3408 lb</i>	<i>\$3,237.60</i>



	<i>system of the conveyor belt system</i>		<i>Trading Co., Ltd.</i>			
<i>Shoe Sliders</i>	<i>Pushes the package to desired location</i>	<a href="#">Link</a>	<i>Ningbo Leison Motor Co., Ltd.</i>	<i>\$5.98</i>	<i>300</i>	<i>\$1,794.00</i>
<b>Grand Total</b>	<b>\$11,630.61</b>					

## Software Bill of Materials - Device Control

<i>Item</i>	<i>Description</i>	<i>Link</i>	<i>Manufacturer</i>	<i>Price per unit</i>	<i>Quantity</i>	<i>Total price</i>
<i>mySQL Enterprise Edition</i>	<i>Database software used to store occupant preferences for work space</i>	<a href="#">Link</a>	<i>Oracle Corporation</i>	<i>\$5000/year</i>	<i>1</i>	<i>\$5000/year</i>
<i>Google Machine Learning</i>	<i>Machine Learning algorithm</i>	<a href="#">Link</a>	<i>Google Inc.</i>	<i>\$0.48/month</i>	<i>1</i>	<i>\$0.48/month</i>



<i>Service</i>	<i>used to optimize energy efficiency</i>					
<i>Google Internet of Things Core</i>	<i>Core that connects all sensors and devices to the machine learning algorithm</i>	<a href="#">Link</a>	<i>Google Inc.</i>	<i>\$0.0045/megabyte</i>	<i>1</i>	<i>\$0.0045/megabyte</i>
<i>Admiral Blue Communication Service</i>	<i>Integrates all smartpipe sensors and transmits into machine learning</i>	<a href="#">Link</a>	<i>Sigfox</i>	<i>\$2/year</i>	<i>1</i>	<i>\$2/year</i>
<b>Grand Total</b>	<b>\$5,010.46/year</b>					

## Hardware Bill of Materials - Device Control

<i>Item</i>	<i>Description</i>	<i>Link</i>	<i>Manufacturer</i>	<i>Price per unit</i>	<i>Quantity</i>	<i>Total price</i>
<i>Zebra Dart Hub RFID</i>	<i>RFID reader that</i>	<a href="#">Link</a>	<i>Zebra</i>	<i>\$2000</i>	<i>4</i>	<i>\$8000</i>



<i>reader</i>	<i>incorporates UWB (ultra wide band) and RTLS (real time locating system) and</i>					
<i>Zebra Dart tags</i>	<i>RFID tags to be carried by employees to gain entrance into building and implement employee preferences</i>	<a href="#">Link</a>	<i>Zebra</i>	<i>\$10</i>	<i>100</i>	<i>\$1000</i>
<i>Bolt + Keypad with bridge and bolt</i>	<i>Smart lock for front door that will open automatically with close RFID proximity, has keypad entry and physical key options for failsafes</i>	<a href="#">Link</a>	<i>Lockitron</i>	<i>\$228</i>	<i>1</i>	<i>\$228</i>
<i>Elk 6050</i>	<i>Photoelectric</i>	<a href="#">Link</a>	<i>Elk</i>	<i>\$128</i>	<i>53</i>	<i>\$6784</i>





<i>smoke detector</i>	<i>Smoke Detector with heat sensor for location based fire prevention</i>					
<i>Elk-M1XRF TW two way transceiver for Elk 6050 Smoke detectors</i>	<i>Will be able to receive data from an ELK smoke detector that is going off and direct the sprinkler system to put out the fire in only that location to prevent water damage</i>	<a href="#">Link</a>	<i>Elk</i>	<i>\$115</i>	<i>1</i>	<i>\$115</i>
<i>Smart-thing Motion Sensor (3 pack)</i>	<i>Samsung IoT Connected Motion Sensor</i>	<a href="#">Link</a>	<i>Samsung</i>	<i>\$71.99</i>	<i>4</i>	<i>\$287.96</i>
<i>LMS SE HE PIR MULTI</i>	<i>Light and Motion Combination Sensor</i>	<a href="#">Link</a>	<i>SLEprojects</i>	<i>\$60</i>	<i>28</i>	<i>\$1680</i>



<i>EagleAX Plant Controller</i>	<i>Main Controller unit, also comes with energy monitoring and HVAC optimization software to incorporate into machine learning software</i>	<a href="#">Link</a>	<i>Honeywell</i>	<i>\$500</i>	<i>4</i>	<i>\$2000</i>
<i>CoinT</i>	<i>RFID Temperature and Humidity Sensor</i>	<a href="#">Link</a>	<i>ELA Innovation</i>	<i>\$50</i>	<i>29</i>	<i>\$1450</i>
<i>APC BE850M2 Back-UP</i>	<i>Circuit Protection and battery backup for EagleAX controller</i>	<a href="#">Link</a>	<i>APC</i>	<i>\$109.99</i>	<i>1</i>	<i>\$109.99</i>
<i>NI202 RS485 &amp; PULSE</i>	<i>Thermal sensor for HVAC</i>	<a href="#">Link</a>	<i>Next Industries</i>	<i>~\$355</i>	<i>27</i>	<i>\$9585</i>
<i>Turnkey IoT Home</i>	<i>Earthquake monitor</i>		<i>Raspberry Shake</i>	<i>\$374.99</i>	<i>1</i>	<i>\$374.99</i>



<i>Earthquake Monitor</i>						
<i>FX3G Series Logic Module</i>	<i>Control conveyor belts for parcel delivery</i>	<a href="#">Link</a>	<i>Mitsubishi</i>	<i>\$409.35</i>	<i>1</i>	<i>\$409.35</i>
<i>Smart Temperature Transmitters</i>	<i>Measures temperature at any given time</i>	<a href="#">Link</a>	<i>Omni Instruments</i>	<i>\$50</i>	<i>27</i>	<i>\$1350</i>
<i>Variable Area Vane-Style Flow Meter for 0.5-20 GPM</i>	<i>Controls flow of water up to 20 GPM</i>	<a href="#">Link</a>	<i>Universal Flow Motors</i>	<i>\$500</i>	<i>27</i>	<i>\$13,500</i>
<i>Aquamonitor Greenstar Wireless Water Meter</i>	<i>Measures water usage with wireless communication</i>	<a href="#">Link</a>	<i>Reduction Revolution</i>	<i>\$279.95</i>	<i>27</i>	<i>\$7558.65</i>
<i>Grand Total</i>						<i>\$31,239.95</i>



## Bill of Materials Zero-Waste Building

<i>Item</i>	<i>Description</i>	<i>Link</i>	<i>Manufacturer</i>	<i>Price per Unit</i>	<i>Quantity</i>	<i>Price</i>
Portland Cement Concrete	Normal Weight, reinforced.	<a href="#">Link</a>		\$998.39 per cubic meter	206.88 $m^3$	\$206,550.76
Bar Reinforcing Steel	Reinforced, otherwise basic.	<a href="#">Link</a>		\$1.81 per pound	37,394.67 lb	\$67,684.34
Smart Windows	Deflect 53% of sunlight and 77% of heat	<a href="#">Link</a>	Guardian Glass-ClimaGuard 53/23	\$3.29 per sq. ft	10344 $ft^2$	\$33,515
<i>Grand Total</i>						\$307,750.10

## Eco-Friendly Power Supply Bill of Materials

<i>Item</i>	<i>Description</i>	<i>Link</i>	<i>Manufacturer</i>	<i>Price per unit (\$)</i>	<i>Quantity</i>	<i>Total price (\$)</i>
Thermal	Used to heat	<a href="#">Link</a>	DualSun	320/panel	60	\$19,200



<i>Panels</i>	<i>water</i>					
<i>Solar Panels</i>	<i>Used to generate electricity</i>	<a href="#">Link</a> <a href="#">Link</a>	<i>SolarWorld</i>	<i>320/panel</i>	<i>60</i>	<i>\$19,200</i>
<i>Solar Tiles</i>	<i>Same as above</i>	<a href="#">Link</a>	<i>Tesla</i>	<i>36/ft^2</i>	<i>1100</i>	<i>\$40,000</i>
<i>Solar Trackers</i>	<i>Guides the Solar Tiles</i>	<a href="#">Link</a>	<i>Newport</i>	<i>1000</i>	<i>4</i>	<i>\$4,000</i>
<i>Pump</i>	<i>Pump water up the building</i>	<a href="#">Link</a>	<i>Sanlian</i>	<i>1000</i>	<i>1</i>	<i>\$1,000</i>
<i>Copper Piping (3.81-cm)</i>	<i>Carry water</i>	<a href="#">Link</a>	<i>Grainger</i>	<i>3/ft</i>	<i>40000</i>	<i>\$120,000</i>
<i>Copper Piping (7.62-cm)</i>	<i>Transport Water</i>	<a href="#">Link</a>	<i>Grainger</i>	<i>25/ft</i>	<i>150</i>	<i>\$3,750</i>
<i>Electricity Storage</i>	<i>Backup Energy</i>	<a href="#">Link</a>	<i>Larson Electronics</i>	<i>120000</i>	<i>1</i>	<i>\$120,000</i>
<i>Linear Slides</i>	<i>Motor and Actuation of Trackers</i>	<a href="#">link</a>	<i>McMaster Carr</i>	<i>23</i>	<i>1000</i>	<i>\$23,000</i>
<b><i>Grand Total</i></b>						<b><i>\$350,150</i></b>



## Conclusion

The Solarflair has had the unique opportunity to integrate state-of-the-art materials and systems to update UCI's overall efficiency. Separately all considering energy and efficiency, the nickname has become the Efficientis, as energy use was already lowered by 38%. Addition of solar panels, AI, and delivery systems has only lowered the use of energy. All integrated systems were considered with the structure's integrity and dead loads, and will not affect the safety of this Risk IV building. Seismic activity has also been lowered so significantly that all systems were be minutely to not at all affected by the typical earthquakes of Orange County. The Friction Pendulum Bearing system saves resources, including money, in that material used in the surface area to brace against seismic shear forces is reduced.



## Works Cited

- “Highlights.” *Sunwater Solar What Is Solar Thermal Comments*,  
sunwatersolar.com/solar-thermal/what-is-solar-thermal.
- Matasci, Sara. “2018 Average Cost of Solar Panels in the U.S. | EnergySage.” *Solar News*,  
EnergySage, 9 May 2018,  
news.energysage.com/how-much-does-the-average-solar-panel-installation-cost-in-the-u-  
s/.
- “Portable Solar Power Battery Pack.” *Larson Electronics*.  
*www.larsonelectronics.com/p-146391-.aspx?keyword=&gclid=CjwKCAjwrqnYBRB-Eiw  
AthnBFkkZ-ILKBpz3-RqduOyCYdlQJddoSMKacBmYTaX\_0UFP-62ounUOlRoCI5AQA  
vD\_BwE*
- “Solar Photovoltaic Technology Basics.” *Research Team Engineers a Better Plastic-Degrading  
Enzyme | News | NREL*, [www.nrel.gov/workingwithus/re-photovoltaics.html](http://www.nrel.gov/workingwithus/re-photovoltaics.html).
- “SolarWorld SW295W Mono Solar Panel Clear Frame.” *SunSpark 260W Solar Panel - Made in  
the USA - Solar Panels For Home Solar Panels*,  
[www.gogreensolar.com/products/solarworld-sw295w-mono-solar-panel-clear-frame](http://www.gogreensolar.com/products/solarworld-sw295w-mono-solar-panel-clear-frame).
- Benson, Adam. “Retrofitting Commercial Real Estate: Current Trends and Challenges in  
Increasing Building Energy Efficiency.” 2011. *UCA Institute of the Environment and  
Sustainability*. Web. [www.ioes.ucla.edu](http://www.ioes.ucla.edu). Accessed: 27 May 2018
- Kravchuk, Nickolay & Colquhoun, Ryan & Porhaba, Ali. “Development of a Friction Pendulum  
Bearing Base Isolation System for Earthquake Engineering Education.” *CSU  
Sacramento*. 2008. Page 4. Print
- Unknown. “Climaguard 53/23.” *Guardian ClimaGuard*. Web. [www.guardianclass.com](http://www.guardianclass.com).  
Accessed: 27 May 2018
- Unknown. “Price Index for Selected Highway Construction Items.” *California Department of*



- Transportation. Web. 2017. Accessed: 27 May 2018
- Unknown. "Solar & Thermal Control Glasses in Burj Khalifa." *Glazette*. 2012. Web. Accessed: 27 May 2018.
- Warner, Jefferey L. "Utility and Economic benefits and Electrochromic Smart Windows." *American Council for an Energy Efficient Economy, Southern California Edison Company*. 1992. Web. [www.aceee.org](http://www.aceee.org). Accessed 27 May 2018
- "Conveyor Belt,2Ply 100,RMV Wht,16InW." *Grainger - For the Ones Who Get It Done.*, [www.grainger.com/product/APACHE-INC-Conveyor-Belt-36TA68](http://www.grainger.com/product/APACHE-INC-Conveyor-Belt-36TA68).
- "General Purpose AC Motors." *Grainger - For the Ones Who Get It Done.*, [www.grainger.com/category/general-purpose-ac-motors/general-purpose-ac-motors/motors/ecatalog/N-ls8](http://www.grainger.com/category/general-purpose-ac-motors/general-purpose-ac-motors/motors/ecatalog/N-ls8).
- Jiang, Jess. "The Price Of Electricity In Your State." *NPR*, NPR, 28 Oct. 2011, [www.npr.org/sections/money/2011/10/27/141766341/the-price-of-electricity-in-your-state](http://www.npr.org/sections/money/2011/10/27/141766341/the-price-of-electricity-in-your-state).