

# UC Berkeley

## UC Berkeley Previously Published Works

### Title

Optimal design with probabilistic objective and constraints

### Permalink

<https://escholarship.org/uc/item/5pv8m4mv>

### Journal

Journal of Engineering Mechanics-ASCE, 132(1)

### ISSN

0733-9399

### Authors

Royset, J O  
Kiureghian, A D  
Polak, E

### Publication Date

2006

Peer reviewed

## Optimal Design with Probabilistic Objective and Constraints

Johannes O. Royset<sup>1</sup>, Associate Member, ASCE

Armen Der Kiureghian<sup>2</sup>, Member, ASCE

and Elijah Polak<sup>3</sup>

### ABSTRACT

Significant challenges are associated with solving optimal structural design problems involving the failure probability in the objective and constraint functions. In this paper, we develop gradient-based optimization algorithms for estimating the solution of three classes of such problems in the case of continuous design variables. Our approach is based on a sequence of approximating design problems, which is constructed and then solved by a semi-infinite optimization algorithm. The construction consists of two steps: First, the failure probability terms in the objective function are replaced by auxiliary variables resulting in a simplified objective function. The auxiliary variables are determined automatically by the optimization algorithm. Second, the failure probability constraints are replaced by a parameterized first-order approximation. The parameter values are determined in an adaptive manner based on separate estimations of the failure probability. Any computational reliability method, including FORM, SORM and Monte Carlo simulation, can be used for this purpose. After repeatedly solving the approximating problem, an approximate solution of the original design problem is found, which satisfies the failure probability constraints at a precision level corresponding to the selected reliability method. The approach is illustrated

---

<sup>1</sup>Research Assistant Professor, Dept. of Operations Research, Naval Postgraduate School, 239 Glasgow Hall, Monterey, CA 93943. E-mail: joroyset@nps.edu.

<sup>2</sup>Taisei Professor, Dept. of Civ. & Env. Engrg., Univ. of California, 721 Davis Hall, Berkeley, CA 94720. E-mail: adk@ce.berkeley.edu.

<sup>3</sup>Emeritus Professor, Dept. of Elect. Engrg. & Comp. Sciences, Univ. of California, Berkeley, CA 94720. E-mail: polak@eecs.berkeley.edu.

by a series of examples involving optimal design and maintenance planning of a reinforced concrete bridge girder.

**Keywords:** Reliability-based optimal design, optimal maintenance strategies, optimization algorithms, semi-infinite optimization, successive approximations.

## INTRODUCTION

Uncertainty, feasibility, and optimality are major considerations in structural design. Uncertainty, arising from randomness in structural materials and applied loads as well as from errors in behavioral models, is inevitable and must be properly accounted to assure safety and reliability. Feasibility is achieved when a design satisfies practical and codified constraints, and hence is an essential requirement. Optimality is desirable in order to maximize benefits and make effective use of resources. Thus, optimal design under uncertainty, which also addresses feasibility, is a topic of significant practical interest in structural engineering. Due to the challenges present in both probabilistic analysis and optimal design of structures, the combined problem poses significant difficulties as well as opportunities for research and innovation.

The theory of structural reliability (see, e.g., Ditlevsen and Madsen 1996) leads to a general but mathematically problematic definition of the failure probability of a structure. Specifically, the failure probability is usually expensive to estimate and there is no simple expression for its gradient with respect to design variables. This situation renders standard gradient-based nonlinear programming algorithms, such as NLPQL (Schittkowski 1985), LANCELOT (Conn et al. 1992), and NPSOL (Gill et al. 1998) inapplicable for the solution of optimization problems involving the failure probability. In an effort to construct alternative algorithms, a large number of researchers have derived theory and/or heuristics for various optimization problems involving the failure probability. In the following, some of the most important results are summarized. See Royset et al. (2002) for a more comprehensive review.

Gradient-free optimization algorithms are theoretically applicable to most optimal design

problems with failure probabilities in the objective function and/or as constraints (e.g., Itoh and Liu 1999, Nakamura et al. 2000, and Beck et al. 1999). However, such algorithms tend to be computationally expensive and impractical for problems with continuous design variables. This is particularly the case when the problems involve functions that are costly to evaluate and have more than a few design variables. On the other hand, gradient-free algorithms can be efficient when applied to discrete optimization problems, but such problems are not discussed in this paper.

Optimal design problems can be dealt with by using smooth response surfaces (e.g., Gasser and Schueller 1998, Igusa and Wan 2003) or surrogate functions (e.g., Torczon and Trosset 1998, Eldred et al. 2002) combined with standard nonlinear programming algorithms. These approaches can be numerically robust, but their accuracy and efficiency strongly depend on the quality of the approximating surfaces and functions and the computational cost of establishing them.

Other attempts to solve optimal design problems with probabilistic functions employ the First-Order Reliability Method (FORM) (see Ditlevsen and Madsen (1996) and the next section). In Enevoldsen and Sorensen (1994), the failure probability is expressed in terms of the reliability index obtained from FORM analysis. However, the reliability index may not have continuous gradients with respect to the design variables even for simple cases (see Royset et al. (2004) for an example) and, hence, in such an approach gradient-based optimization algorithms are not guaranteed to obtain a solution. In Madsen and Friis Hansen (1992) and Kuschel and Rackwitz (2000), the failure probability is replaced by the optimality conditions associated with the design point. This eliminates the need for computing the reliability index during the design optimization. However, the approach requires second-order sensitivities of the structural response, which are rarely available, and it may also lead to ill-conditioned optimization problems (see Royset et al. (2001b) for an explanation). For the use of the FORM approximation in multi-disciplinary design optimization, see Agarwal et al. (2003).

The approaches developed by Kirjner-Neto et al. (1998) and Royset et al. (2001a) are also based on first-order approximations. However, these approaches employ a reformulation of the problem, which avoids the need for the gradient of the reliability index. Furthermore, by adjusting certain parameters, these formulations lead to approximate optimal design solutions for higher-order reliability methods, e.g., the Second-Order Reliability Method (SORM) or the Monte Carlo Simulation (MCS) method. The reformulated problem is a semi-infinite optimization problem, for which several well known algorithms exist (see Polak 1997 Chapter 3.5). By definition, problems involving a finite number of design variables and an infinite number of constraints are called semi-infinite optimization problems (Polak 1997 Chapter 3). For example, the optimization problem to minimize  $c(x_1, x_2, \dots, x_n)$  subject to the constraints  $g(x_1, x_2, \dots, x_n, u) \leq 0$  for all  $u \in [-1, 1]$  is semi-infinite. A formulation similar to that of Kirjner-Neto et al. (1998) was derived independently by Tu and Choi (1997) and Tu et al. (1999). However, in these references the connection to semi-infinite optimization was not made clear and an efficient algorithm was not proposed.

Kirjner-Neto et al. (1998) and Royset et al. (2001a) address optimization problems involving failure probabilities in the objective *or* constraint set definitions. Royset et al. (2001b) contains an initial study on problems with failure probabilities in *both* the objective and the constraint set definitions. This is the topic of the present study. However, we follow a different path from the one in Royset et al. (2001b). The approach in this paper builds on the ideas in Kirjner-Neto et al. (1998) and Royset et al. (2001a).

Many researchers have studied applications of reliability-based optimal design in various disciplinary areas. In Lin and Frangopol (1996) the focus is on reinforced concrete girders. Mahadevan (1992) and Liu and Moses (1992) address frame and truss structures, respectively. An overview of applications can be found in Thoft-Christensen (1991).

The objective of this paper is to present new gradient-based algorithms for reliability-based optimal design for three classes of problems involving two-state structural components and systems. Specifically, we consider the important case with component or series system

failure probabilities appearing in both the objective and the constraint set. Through a series of reformulations, we construct approximating problems which can be solved by semi-infinite optimization algorithms. By solving these approximating problems, we obtain a design that is guaranteed to satisfy structural and failure probability constraints and is approximately optimal. An important advantage of the approach is that the reliability and optimization calculations are decoupled, thus allowing flexibility in the choice of the method for computing failure probabilities.

The following section gives an overview of the necessary elements in structural reliability theory. This is followed by the definition of the optimal design problems considered. The main part of the paper consists of two sections with derivations of optimization algorithms. The paper ends with a comprehensive set of numerical examples from the area of highway bridge design and maintenance.

## ELEMENTS OF STRUCTURAL RELIABILITY

In accordance with Ditlevsen and Madsen (1996), we express the reliability of a two-state structure by means of a time-invariant probabilistic model defined in terms of an  $m$ -dimensional vector of random variables  $\mathbf{V}$ . Let  $\mathbf{x}$  be an  $n$ -dimensional vector of deterministic design variables, e.g., member sizes, maintenance times, or parameters in the distribution of  $\mathbf{V}$ . The state of the structure is defined in terms of one or more real-valued limit-state functions  $G_k(\mathbf{x}, \mathbf{v})$ ,  $k \in \mathbf{K} = \{1, 2, \dots, K\}$ , where  $\mathbf{v}$  is a realization of the random vector  $\mathbf{V}$ . By convention, each  $G_k(\mathbf{x}, \mathbf{v})$  is formulated such that  $G_k(\mathbf{x}, \mathbf{v}) \leq 0$  describes the failure of the structure with respect to a specific performance requirement.

Several computational reliability methods require a bijective transformation of realizations  $\mathbf{v}$  of the random vector  $\mathbf{V}$  into realizations  $\mathbf{u}$  of a standard normal random vector  $\mathbf{U}$ . Such transformations can be defined under weak assumptions. For a given design vector  $\mathbf{x}$ , let  $\mathbf{u} = \mathbf{T}_{\mathbf{x}}(\mathbf{v})$  represent this transformation. Replacing  $\mathbf{v}$  by  $\mathbf{T}_{\mathbf{x}}^{-1}(\mathbf{u})$  defines the equivalent limit-state functions  $g_k(\mathbf{x}, \mathbf{u}) = G_k(\mathbf{x}, \mathbf{T}_{\mathbf{x}}^{-1}(\mathbf{u}))$ .

A limit-state function  $g_k(\mathbf{x}, \mathbf{u})$ , together with the rule that  $g_k(\mathbf{x}, \mathbf{u}) \leq 0$  defines failure,

is referred to as a component. A component may or may not be associated with a physical member of the structure. For structural reliability problems of interest here,  $g_k(\mathbf{x}, \mathbf{0}) > 0$  for all realistic designs.

We define the failure probability of the  $k$ -th component by

$$p_k(\mathbf{x}) = \int_{\Omega_k(\mathbf{x})} \varphi(\mathbf{u}) d\mathbf{u}, \quad (1)$$

where  $\varphi(\mathbf{u})$  is the  $m$ -dimensional standard normal probability density function and

$$\Omega_k(\mathbf{x}) = \{\mathbf{u} \in \mathbb{R}^m \mid g_k(\mathbf{x}, \mathbf{u}) \leq 0\} \quad (2)$$

is the failure domain. The boundary of  $\Omega_k(\mathbf{x})$  is referred to as the limit-state surface. For a given design  $\mathbf{x}$ , we define the *critical component* to be the component with the largest failure probability  $p_k(\mathbf{x})$ .

A collection of components, together with a rule defining combinations of component failures as system failure, is referred to as a structural system. The system failure probability of the structure is defined by

$$p(\mathbf{x}) = \int_{\Omega(\mathbf{x})} \varphi(\mathbf{u}) d\mathbf{u}, \quad (3)$$

where  $\Omega(\mathbf{x})$  is the failure domain for the system. We say the probabilistic model of the structure is a series structural system, whenever the failure domain is given by

$$\Omega(\mathbf{x}) = \bigcup_{k \in \mathbf{K}} \{\mathbf{u} \in \mathbb{R}^m \mid g_k(\mathbf{x}, \mathbf{u}) \leq 0\}. \quad (4)$$

This paper deals exclusively with series structural systems. It is well known that for such systems  $\max_{k \in \mathbf{K}} p_k(\mathbf{x}) \leq p(\mathbf{x}) \leq \sum_{k \in \mathbf{K}} p_k(\mathbf{x})$ . Thus, the critical component makes a dominant contribution to the series system failure probability.

A FORM approximation to  $p_k(\mathbf{x})$  is obtained by linearizing the limit-state function  $g_k(\mathbf{x}, \mathbf{u})$  with respect to  $\mathbf{u}$  at the point on the limit-state surface  $\{\mathbf{u} \in \mathbb{R}^m \mid g_k(\mathbf{x}, \mathbf{u}) = 0\}$

closest to the origin. Let  $\mathbf{u}_k^*(\mathbf{x})$  be such a closest point, i.e.,

$$\mathbf{u}_k^*(\mathbf{x}) \in \arg \min_{\mathbf{u} \in \mathbb{R}^m} \{ \|\mathbf{u}\| \mid g_k(\mathbf{x}, \mathbf{u}) = 0 \}. \quad (5)$$

Such closest points are referred to as design points. It can be shown that the FORM approximation of the component failure probability takes the form

$$p_k(\mathbf{x}) \approx \Phi(-\beta_k(\mathbf{x})), \quad (6)$$

where  $\beta_k(\mathbf{x}) = \|\mathbf{u}_k^*(\mathbf{x})\|$  is the reliability index and  $\Phi(\cdot)$  is the standard normal cumulative distribution function. Equality holds in (6) when  $g_k(\mathbf{x}, \mathbf{u})$  is affine in  $\mathbf{u}$ , i.e.,  $g_k(\mathbf{x}, \mathbf{u}) = b_{0,k}(\mathbf{x}) + \mathbf{b}_k(\mathbf{x})^T \mathbf{u}$  for some positive-valued function  $b_{0,k}(\mathbf{x})$  and vector-valued function  $\mathbf{b}_k(\mathbf{x})$ . Other reliability approximation methods include SORM, MCS, response surface and various importance sampling methods (Ditlevsen and Madsen 1996). In this paper, in addition to FORM, we make use of MCS.

## PROBLEM STATEMENT

This paper addresses three broad classes of reliability-based optimal structural design problems frequently arising in practice. The three problems are denoted  $\mathbf{P}_3$ ,  $\mathbf{P}_{3,\text{sys}}$  and  $\mathbf{P}_{3,\text{por}}$  and are defined below. These problems are generalizations of the reliability-based optimal design problems  $\mathbf{P}_1$ ,  $\mathbf{P}_{1,\text{sys}}$ ,  $\mathbf{P}_2$  and  $\mathbf{P}_{2,\text{sys}}$  defined and solved in Royset et al. (2001a).

$\mathbf{P}_3$  is defined as

$$\mathbf{P}_3 \quad \min_{\mathbf{x} \in \mathbb{R}^n} \left\{ c_0(\mathbf{x}) + \sum_{k=1}^K c_k(\mathbf{x}) p_k(\mathbf{x}) \mid p_k(\mathbf{x}) \leq \hat{p}_k, k \in \mathbf{K}, \mathbf{x} \in \mathbf{X} \right\}, \quad (7)$$

where  $\mathbf{x} \in \mathbb{R}^n$  is the design vector,  $\mathbf{X} = \{\mathbf{x} \in \mathbb{R}^n \mid f_j(\mathbf{x}) \leq 0, j \in \mathbf{q}\}$  is a deterministic constraint set,  $f_j(\mathbf{x}), j \in \mathbf{q} = \{1, 2, \dots, q\}$ , are real-valued deterministic constraint functions,  $c_k(\mathbf{x}), k \in \{0, 1, \dots, K\}$ , are real-valued cost functions, and the values  $\hat{p}_k, k \in \mathbf{K}$ , are pre-defined acceptable upper bounds on the component failure probabilities.



Depending on the form of the cost functions  $c_k(\mathbf{x})$ ,  $k \in \{0, 1, \dots, K\}$ ,  $\mathbf{P}_3$  and its objective function  $c_0(\mathbf{x}) + \sum_{k=1}^K c_k(\mathbf{x})p_k(\mathbf{x})$  can be interpreted in various ways. For example, if  $c_0(\mathbf{x})$  is the initial design cost and  $c_k(\mathbf{x}) = 0$ ,  $k \in \mathbf{K}$ , then  $\mathbf{P}_3$  is the problem of minimizing the initial cost. When  $c_k(\mathbf{x})$  is the failure cost of the  $k$ -th component and the cost of no failure is zero, the expected failure cost of the  $k$ -th component becomes  $c_k(\mathbf{x})p_k(\mathbf{x}) + 0(1 - p_k(\mathbf{x}))$ . Hence, when the expected failure costs of the components are additive, the objective function  $c_0(\mathbf{x}) + \sum_{k=1}^K c_k(\mathbf{x})p_k(\mathbf{x})$  is the initial cost plus the expected failure cost. Consequently, in this case  $\mathbf{P}_3$  can be interpreted as the problem to minimize the initial cost plus the expected failure cost, subject to reliability and deterministic constraints. Of course the initial cost,  $c_0(\mathbf{x})$ , and the failure costs,  $c_k(\mathbf{x})$ ,  $k \in \mathbf{K}$ , could themselves be functions of other random variables, such as uncertain costs of materials and labor. In such cases, we define these cost functions to be expected values over the distributions of these random variables. Note that these expectations can be computed outside our optimization algorithm.

$\mathbf{P}_{3,\text{sys}}$  is defined as

$$\mathbf{P}_{3,\text{sys}} \quad \min_{\mathbf{x} \in \mathbb{R}^n} \{c_0(\mathbf{x}) + c(\mathbf{x})p(\mathbf{x}) \mid p(\mathbf{x}) \leq \hat{p}, \mathbf{x} \in \mathbf{X}\}, \quad (8)$$

where  $p(\mathbf{x})$  is the system failure probability as defined in (3) and (4),  $c(\mathbf{x})$  is a cost function, and  $\hat{p}$  is a pre-defined acceptable upper bound on the system failure probability. As in the case of  $\mathbf{P}_3$ ,  $\mathbf{P}_{3,\text{sys}}$  can be interpreted in various ways depending on the form of the cost functions. For example, if  $c(\mathbf{x})$  is the cost of system failure and the cost of no system failure is zero, then the objective function  $c_0(\mathbf{x}) + c(\mathbf{x})p(\mathbf{x})$  can be interpreted as the initial cost plus the expected cost of system failure. Consequently, in this case  $\mathbf{P}_{3,\text{sys}}$  defines the problem to minimize the initial cost plus the expected cost of system failure, subject to system reliability and deterministic constraints. Practical examples of  $\mathbf{P}_{3,\text{sys}}$  are found in the section with numerical examples below.

The problem  $\mathbf{P}_{3,\text{sys}}$  can be generalized to include more than one structural system. Consider the simultaneous design of  $L$  structures, where  $\mathbf{x} \in \mathbb{R}^n$  is the vector containing the

design variables for all the structures. An example of an optimization problem involving several structures would be the design of retrofit strategies for a collection of bridges. Let each structure be modelled as a series system and the corresponding failure probability  $p^{(l)}(\mathbf{x}), l \in \mathbf{L} = \{1, \dots, L\}$ , of the  $l$ -th structure be defined by (3) and (4). The  $k$ -th limit-state function of the  $l$ -th structure is denoted  $g_k^{(l)}(\mathbf{x}, \mathbf{u}), k \in \mathbf{K}_l = \{1, \dots, K_l\}, l \in \mathbf{L}$ . We refer to such collections of structural systems as portfolios of structures. The corresponding design optimization problem, denoted  $\mathbf{P}_{3,\text{por}}$ , is defined by

$$\mathbf{P}_{3,\text{por}} \quad \min_{\mathbf{x} \in \mathbb{R}^n} \left\{ \sum_{l=1}^L c_0^{(l)}(\mathbf{x}) + \sum_{l=1}^L c^{(l)}(\mathbf{x}) p^{(l)}(\mathbf{x}) \mid p^{(l)}(\mathbf{x}) \leq \hat{p}^{(l)}, l \in \mathbf{L}, \mathbf{x} \in \mathbf{X} \right\}, \quad (9)$$

where  $c_0^{(l)}(\mathbf{x})$  and  $c^{(l)}(\mathbf{x}), l \in \mathbf{L}$ , are cost functions associated the  $l$ -th structure and  $\hat{p}^{(l)}, l \in \mathbf{L}$ , are predefined acceptable upper bounds. As for the previous problems, the cost functions in  $\mathbf{P}_{3,\text{por}}$  can be interpreted in various ways to reflect different decision making situations. In the following, we focus primarily on  $\mathbf{P}_3$  and  $\mathbf{P}_{3,\text{por}}$ . The solution strategy for  $\mathbf{P}_{3,\text{sys}}$  follows as a special case of the one for  $\mathbf{P}_{3,\text{por}}$  with  $L = 1$ .

The problems  $\mathbf{P}_3, \mathbf{P}_{3,\text{sys}}$ , and  $\mathbf{P}_{3,\text{por}}$  involve the failure probability, and hence, standard nonlinear programming algorithms are inapplicable for the following two reasons: (i)  $p(\mathbf{x})$  and  $p_k(\mathbf{x})$  cannot be computed exactly and, hence, must be estimated, and (ii) there are no simple expressions for the gradients of  $p(\mathbf{x})$  and  $p_k(\mathbf{x})$  or their approximations. For example, the failure probability approximations based on FORM and SORM may not be continuously differentiable because the design point may make a jump as a design parameter is varied. Consequently, the use of a standard nonlinear programming algorithm for solving the above problems, implemented in some ad-hoc manner, is not guaranteed to find a solution.

### ALGORITHM FOR $\mathbf{P}_3$

Since  $\mathbf{P}_3$  cannot generally be solved using standard nonlinear programming algorithms, we aim to construct an approximating problem for  $\mathbf{P}_3$  that can be solved by some other optimization algorithm. Our derivation consists of two steps, including the definition of one

intermediate optimization problem. The intermediate problem is obtained by replacing the failure probabilities in the objective function of  $\mathbf{P}_3$  with variables. The variables are included in an augmented design vector and their values are automatically determined as part of the minimization.

Let  $\bar{\mathbf{x}} = (\mathbf{x}, \mathbf{a}) \in \mathbb{R}^{n+K}$  be the augmented design vector, where  $\mathbf{x} \in \mathbb{R}^n$  is the original design vector and  $\mathbf{a} = (a_1, \dots, a_K) \in \mathbb{R}^K$  is a vector of  $K$  variables. We define the intermediate optimization problem as

$$\bar{\mathbf{P}}_3 \quad \min_{(\mathbf{x}, \mathbf{a}) \in \mathbb{R}^{n+K}} \left\{ c_0(\mathbf{x}) + \sum_{k=1}^K c_k(\mathbf{x})a_k \mid p_k(\mathbf{x}) \leq a_k, 0 \leq a_k \leq \hat{p}_k, k \in \mathbf{K}, \mathbf{x} \in \mathbf{X} \right\}. \quad (10)$$

The equivalence between  $\mathbf{P}_3$  and  $\bar{\mathbf{P}}_3$  is clear from the following argument, where we assume that  $c_k(\mathbf{x}) > 0$  for all  $\mathbf{x} \in \mathbf{X}$ . Suppose that at least one of the constraints  $p_k(\mathbf{x}) \leq a_k, k \in \mathbf{K}$ , is inactive, i.e.,  $p_{k^*}(\mathbf{x}) < a_{k^*}$  for some  $k^* \in \mathbf{K}$ . Then, because  $c_{k^*}(\mathbf{x}) > 0$ , the objective function in  $\bar{\mathbf{P}}_3$  can be reduced in value by decreasing  $a_{k^*}$  without violating the constraints. Hence, every local and global optimal solution of  $\bar{\mathbf{P}}_3$  must have all the constraints  $p_k(\mathbf{x}) \leq a_k, k \in \mathbf{K}$ , active, i.e.,  $p_k(\mathbf{x}) = a_k$  for all  $k \in \mathbf{K}$ . When all the constraints  $p_k(\mathbf{x}) \leq a_k, k \in \mathbf{K}$ , are active, the objective functions in  $\mathbf{P}_3$  and  $\bar{\mathbf{P}}_3$  are identical. In addition, the constraints in  $\bar{\mathbf{P}}_3$  allow the failure probabilities  $p_k(\mathbf{x})$  to vary between 0 and  $\hat{p}_k$ , which is exactly the constraints in  $\mathbf{P}_3$ . Consequently,  $\mathbf{P}_3$  and  $\bar{\mathbf{P}}_3$  have identical solutions. A formal statement with proof can be found in Appendix A. Since  $c_k(\mathbf{x})$  is a cost, the assumption that  $c_k(\mathbf{x}) > 0$  for all  $\mathbf{x} \in \mathbf{X}$  is usually satisfied. One exception occurs when  $c_k(\mathbf{x}) = 0$  for some  $k$  for all designs. In this case, the corresponding auxiliary variables  $a_k$  become superfluous and the reformulation of  $\mathbf{P}_3$  takes the form

$$\min_{(\mathbf{x}, \mathbf{a}) \in \mathbb{R}^{n+K}} \left\{ c_0(\mathbf{x}) + \sum_{k \in \mathbf{K}^*} c_k(\mathbf{x})a_k \mid p_k(\mathbf{x}) \leq a_k, 0 \leq a_k \leq \hat{p}_k, k \in \mathbf{K}^*, \right. \\ \left. p_k(\mathbf{x}) \leq \hat{p}_k, k \in \mathbf{K}^{**}, \mathbf{x} \in \mathbf{X} \right\}, \quad (11)$$

where  $\mathbf{K}^*$  are those  $k \in \mathbf{K}$  with  $c_k(\mathbf{x}) > 0$  for all  $\mathbf{x} \in \mathbf{X}$  and  $\mathbf{K}^{**}$  are those  $k \in \mathbf{K}$  with  $c_k(\mathbf{x}) = 0$  for all designs. The equivalence between (11) and  $\mathbf{P}_3$  can be shown using the same arguments as in the case of  $\mathbf{P}_3$  and  $\overline{\mathbf{P}}_3$ , and the following derivations hold with trivial modifications. For simplicity in the following presentation, we focus on  $\overline{\mathbf{P}}_3$  and not (11).

Since the failure probabilities appear only as constraints and not in the objective function of  $\overline{\mathbf{P}}_3$ ,  $\overline{\mathbf{P}}_3$  is simpler to analyze than  $\mathbf{P}_3$ . However,  $\overline{\mathbf{P}}_3$  still involves failure probabilities and, hence, we proceed by constructing an approximating optimization problem for  $\overline{\mathbf{P}}_3$  (and  $\mathbf{P}_3$ ). For any vector of parameters  $\mathbf{t} = (t_1, \dots, t_K) \in \mathbb{R}^K$ , with positive components, we define

$$\overline{\mathbf{P}}_{3,\mathbf{t}} \quad \min_{\overline{\mathbf{x}}=(\mathbf{x},\mathbf{a}) \in \mathbb{R}^{n+K}} \left\{ c_0(\mathbf{x}) + \sum_{k=1}^K c_k(\mathbf{x})a_k \mid \psi_{k,t_k}(\overline{\mathbf{x}}) \leq 0, 0 \leq a_k \leq \hat{p}_k, k \in \mathbf{K}, \mathbf{x} \in \mathbf{X} \right\}, \quad (12)$$

where

$$\psi_{k,t_k}(\overline{\mathbf{x}}) = \max_{\mathbf{u} \in \mathbb{B}(\mathbf{0},1)} \{-g_k(\mathbf{x}, -\Phi^{-1}(a_k)t_k\mathbf{u})\}, \quad k \in \mathbf{K}, \quad (13a)$$

with  $\Phi^{-1}(\cdot)$  being the inverse of the standard normal cumulative distribution function and, for any  $r > 0$ ,  $\mathbb{B}(\mathbf{0}, r) = \{\mathbf{u} \in \mathbb{R}^m \mid \|\mathbf{u}\| \leq r\}$  being all the points in a ball of radius  $r$ . Since  $\overline{\mathbf{P}}_{3,\mathbf{t}}$  involves a finite number of design variables  $(x_1, x_2, \dots, x_n)$  and an infinite number of constraints  $(-g_k(\mathbf{x}, -\Phi^{-1}(a_k)t_k\mathbf{u}) \leq 0$  for all  $\mathbf{u} \in \mathbb{B}(\mathbf{0}, 1)$ , etc.),  $\overline{\mathbf{P}}_{3,\mathbf{t}}$  is a semi-infinite optimization problem. Such optimization problems are computationally tractable and can be solved by well-tested and convergent semi-infinite optimization algorithms (Polak 1997 Chapter 3.5). Note that in the approximating problem  $\overline{\mathbf{P}}_{3,\mathbf{t}}$ , the failure probability constraints are replaced by constraints on the functions  $\psi_{k,t_k}(\overline{\mathbf{x}})$ . The relation between the two sets of constraints are described in the following.

Using a linear transformation in the radial direction of the  $\mathbf{u}$ -space and the relation between minimization and maximization, we see that

$$\psi_{k,t_k}(\overline{\mathbf{x}}) = - \min_{\mathbf{u} \in \mathbb{B}(\mathbf{0}, -\Phi^{-1}(a_k)t_k)} g_k(\mathbf{x}, \mathbf{u}). \quad (13b)$$

Note that  $-\Phi^{-1}(a_k) > 0$  because  $a_k \leq \hat{p}_k$  and  $\hat{p}_k$  is assumed to be less than 0.5. Suppose for now that  $t_k = 1$ . If  $\psi_{k,1}(\mathbf{x}, \mathbf{a}) \leq 0$ , then by (13b), the limit-state function must be non-negative for all realizations  $\mathbf{u}$  in a ball of radius  $-\Phi^{-1}(a_k)$ . In view of (5), this effectively implies that the distance from the origin to the closest point on the limit-state surface, i.e., the reliability index, is equal to or greater than the radius of the ball, i.e.,  $\beta_k(\mathbf{x}) \geq -\Phi^{-1}(a_k)$ . Hence, in view of (6), we have for the FORM approximation of the  $k$ -th component failure probability  $p_k(\mathbf{x}) \approx \Phi(-\beta_k(\mathbf{x})) \leq a_k$ . The consequence of this finding is twofold: (a) if the limit-state functions  $g_k(\mathbf{x}, \mathbf{u}), k \in \mathbf{K}$ , are affine in their second arguments, then the solutions of  $\bar{\mathbf{P}}_{3,\mathbf{t}}$  with  $t_k = 1, k \in \mathbf{K}$ , are identical to the solutions of  $\bar{\mathbf{P}}_3$  and  $\mathbf{P}_3$ . Clearly, limit-state functions are rarely affine in practice, but this result motivates our approach. (In fact, affine limit-state functions simplify (7) to a standard nonlinear program.) (b) If the limit-state functions  $g_k(\mathbf{x}, \mathbf{u}), k \in \mathbf{K}$ , are nonlinear in their second arguments, then the solution of  $\bar{\mathbf{P}}_{3,\mathbf{t}}$  with  $t_k = 1, k \in \mathbf{K}$ , is identical to the solution of  $\bar{\mathbf{P}}_3$  and  $\mathbf{P}_3$  with the probability terms replaced with their FORM approximations. Consideration for higher-order reliability approximations, e.g., SORM, MCS, can be made by adjusting the parameters  $t_k$ . Specifically, if for a particular solution of  $\bar{\mathbf{P}}_{3,\mathbf{t}}$  the FORM approximation overestimates the failure probability  $p_k(\mathbf{x})$ , the parameter  $t_k$  is adjusted downward, whereas if it underestimates the parameter  $t_k$  is adjusted upward. The solution of  $\bar{\mathbf{P}}_{3,\mathbf{t}}$  with the adjusted parameters must then be checked with the selected higher-order reliability method to make sure that the probability constraints are all satisfied. Further adjustments in the parameters  $t_k$  may be effected to improve the approximation. A specific rule for these iterative adjustments is described in Step 3 of the following algorithm:

**Algorithm 1. (For  $\mathbf{P}_3$ )**

**Data.** Provide an initial design  $\mathbf{x}_0 \in \mathbb{R}^n$  and a sequence of strictly increasing integers

$$N_0, N_1, N_3, \dots$$

**Step 0.** Set  $i = 0, \mathbf{a}_0 = (\hat{p}_1, \dots, \hat{p}_K), \mathbf{t}_0 = (1, \dots, 1) \in \mathbb{R}^K, \bar{\mathbf{x}}_0 = (\mathbf{x}_0, \mathbf{a}_0)$ .

**Step 1.** Set  $\bar{\mathbf{x}}_{i+1} = (\mathbf{x}_{i+1}, \mathbf{a}_{i+1})$  to be the last iterate after  $N_i$  iterations of a semi-infinite optimization algorithm on the problem  $\bar{\mathbf{P}}_{3,t_i}$  with initialization  $\bar{\mathbf{x}}_i$ .

**Step 2.** Compute “appropriate estimates” (see below)  $\tilde{p}_k(\mathbf{x}_{i+1})$  of  $p_k(\mathbf{x}_{i+1})$  for all  $k \in \mathbf{K}$ . If probability estimates are to be based on the FORM approximation, **Stop**. Otherwise, go to **Step 3**.

**Step 3.** For  $k \in \mathbf{K}$ , set

$$(t_k)_{i+1} = \frac{\Phi^{-1}((a_k)_{i+1})}{\Phi^{-1}(\tilde{p}_k(\mathbf{x}_{i+1}))} (t_k)_i, \quad (14a)$$

where  $(a_k)_{i+1}$  is the  $k$ -th component of  $\mathbf{a}_{i+1}$ .

**Step 4.** Replace  $i$  by  $i + 1$  and go to **Step 1**. □

With the phrase “appropriate estimate” in Step 2 of Algorithm 1, we imply that the user must select a suitable computational reliability method, e.g., FORM, SORM, MCS (the latter with a specified precision level, e.g., a maximum 5% coefficient of variation, c.o.v., of the estimate). This selection depends on how precisely the user wishes to compute the probability terms in  $\mathbf{P}_3$ . For example, if the user is satisfied with SORM probability estimates, then  $\tilde{p}_k(\mathbf{x})$  in Step 2 must be computed by means of the SORM. Similarly, if the user wishes to use 5%-c.o.v. probability estimates by MCS, then  $\tilde{p}_k(\mathbf{x})$  in Step 2 must be computed by means of MCS with a 5%-c.o.v. Note that if the FORM estimate is acceptable to the user, then Algorithm 1 stops at Step 2.

Algorithm 1 starts out by solving  $\bar{\mathbf{P}}_{3,t_0}$  with  $\mathbf{t}_0 = \mathbf{1}$ . This yields a “first-order” estimate  $\mathbf{x}_1$  of the optimal design in  $\mathbf{P}_3$  (and values of the auxiliary variables  $\mathbf{a}_1$ ). Then, the failure probabilities  $p_k(\mathbf{x}_1), k \in \mathbf{K}$ , are estimated using any computational reliability method found appropriate for the given application and precision requirements. Using this estimate, Step 3 adjusts  $t_k$  so that, hopefully, the next iteration  $(\mathbf{x}_2, \mathbf{a}_2)$  satisfies  $\tilde{p}_k(\mathbf{x}_2) = (a_k)_2 \leq \hat{p}_k$ . If this is *not* satisfied,  $t_k$  is adjusted again at that time. As Algorithm 1 progresses, the relations  $\tilde{p}_k(\mathbf{x}_i) = (a_k)_i \leq \hat{p}_k$  tend to be satisfied more and more accurately due to the adjustments

of  $t_k$ . It can be shown that for  $t_k \geq -\sqrt{\chi^{-1}(1 - \hat{p}_k)}/\Phi^{-1}(\hat{p}_k)$ , where  $\chi^{-1}(\cdot)$  is the inverse of the chi-square cumulative probability distribution with  $m$  degrees of freedom, every feasible design of  $\bar{\mathbf{P}}_{3,\mathbf{t}}$  is also feasible for  $\mathbf{P}_3$ . Hence,  $t_k$  will not be adjusted upwards indefinitely and the failure probability constraints can be guaranteed to be satisfied.

The motivation behind the rule in (14a) is related to  $\psi_{k,t_k}(\bar{\mathbf{x}})$  (see (13b)): if  $\tilde{p}_k(\mathbf{x}_i) > (a_k)_i$ , then the constraint  $\psi_{k,(t_k)_i}(\bar{\mathbf{x}}_i) \leq 0$  allows the limit-state surface  $\{\mathbf{u} \in \mathbb{R}^m \mid g_k(\mathbf{x}_i, \mathbf{u}) = 0\}$  to come too close to the origin in the  $\mathbf{u}$ -space and the radius of the ball associated with  $\psi_{k,(t_k)_i}(\bar{\mathbf{x}}_i)$  must be increased. The increase of the ball radius is obtained by increasing  $(t_k)_i$  (see (13b)). If  $p_k(\mathbf{x}_i) < (a_k)_i$ , then the constraint  $\psi_{k,(t_k)_i}(\bar{\mathbf{x}}) \leq 0$  forces the limit-state surface to be too far away from the origin in the  $\mathbf{u}$ -space and the size of the ball must be reduced by reducing  $(t_k)_i$ . The appropriate scaling of the increase/decrease of  $(t_k)_i$  in (14a) is obtained by using the ratio of normal variates associated with the probability values. The last step of Algorithm 1 increases the iteration counter and the process is repeated.

In Algorithm 1, it is left to the user to select a semi-infinite optimization algorithm for solving  $\bar{\mathbf{P}}_{3,\mathbf{t}}$ . Many such algorithms can be found in Section 3.5 of Polak (1997) and in references therein. Descriptions of some of these algorithms are also found in Royset et al. (2002). In our numerical examples, we adopt the semi-infinite algorithm in Gonzaga and Polak (1979), which is based on discretization. A simplified version of this algorithm can be described as follows. First, note that  $\bar{\mathbf{P}}_{3,\mathbf{t}}$  can be written as

$$\min_{(\mathbf{x}, \mathbf{a}) \in \mathbb{R}^{n+K}} \left\{ c_0(\mathbf{x}) + \sum_{k=1}^K c_k(\mathbf{x}) a_k \mid \begin{aligned} &g_k(\mathbf{x}, -\Phi^{-1}(a_k)t_k \mathbf{u}) \geq 0 \quad \forall \mathbf{u} \in \mathbb{B}(\mathbf{0}, 1), \\ &0 \leq a_k \leq \hat{p}_k, \quad k \in \mathbf{K}, \quad \mathbf{x} \in \mathbf{X} \end{aligned} \right\}. \quad (14b)$$

We observe that  $\bar{\mathbf{P}}_{3,\mathbf{t}}$  has an infinite number of constraints due to the infinite number of points in  $\mathbb{B}(\mathbf{0}, 1)$ . As an approximation,  $\mathbb{B}(\mathbf{0}, 1)$  is replaced by a finite number of points

$\{\mathbf{u}_k^1, \mathbf{u}_k^2, \dots, \mathbf{u}_k^d\}$  for each limit-state function  $k \in \mathbf{K}$ . This results in an approximate problem

$$\min_{(\mathbf{x}, \mathbf{a}) \in \mathbb{R}^{n+K}} \left\{ c_0(\mathbf{x}) + \sum_{k=1}^K c_k(\mathbf{x})a_k \quad \left| \quad \begin{aligned} g_k(\mathbf{x}, -\Phi^{-1}(a_k)t_k\mathbf{u}_k^j) &\geq 0, \quad j = 1, 2, \dots, d, \\ 0 \leq a_k &\leq \hat{p}_k, \quad k \in \mathbf{K}, \quad \mathbf{x} \in \mathbf{X} \end{aligned} \right. \right\}, \quad (14c)$$

which for a large number of points in the relevant region of  $\mathbb{B}(\mathbf{0}, 1)$  is a good approximation of  $\bar{\mathbf{P}}_{3,t}$ . Under the assumption that the limit-state functions, cost functions and constraint functions have continuous gradients, we see that (14c) is a standard nonlinear program and can be solved using solvers such as NLPQL (Schittkowski 1985), LANCELOT (Conn et al. 1992), and NPSOL (Gill et al. 1998). However, it remains to compute  $\{\mathbf{u}_k^1, \mathbf{u}_k^2, \dots, \mathbf{u}_k^d\}, k \in \mathbf{K}$ . In Gonzaga and Polak (1979), this computation is integrated with the solution of (14c). Conceptually, the algorithm in Gonzaga and Polak (1979) takes the following form when applied to  $\bar{\mathbf{P}}_{3,t}$ : (i) Initialize  $\mathbf{x}'_1, \mathbf{a}'_1$  and set  $j = 1$ . (ii) For each  $k \in \mathbf{K}$ , compute  $\mathbf{u}_k^j$  as the solution of  $\min_{\mathbf{u} \in \mathbb{B}(\mathbf{0}, 1)} g_k(\mathbf{x}'_j, -\Phi^{-1}((a'_k)_j)t_k\mathbf{u})$ . (iii) Compute  $\mathbf{x}'_{j+1}$  and  $\mathbf{a}'_{j+1}$  by performing one iteration of a nonlinear programming algorithm applied to (14c) with  $d = j$ . (iv) Replace  $j$  by  $j + 1$  and go to (ii). Note that since  $d$  is increasing, (14c) is gradually becoming a better approximation of  $\bar{\mathbf{P}}_{3,t}$ . The semi-infinite algorithm in Gonzaga and Polak (1979), which we use in the numerical examples, is much more efficient than indicated by the conceptual description above. In particular, the algorithm in Gonzaga and Polak (1979) includes an adaptive termination test in step (ii) and constraint trimming in step (iii).

Note that for semi-infinite optimization algorithms to be applicable, the functions  $c_0(\mathbf{x})$ ,  $c_k(\mathbf{x})$ ,  $k \in \mathbf{K}$ ,  $f_j(\mathbf{x})$ ,  $j \in \mathbf{q}$ , and  $g_k(\mathbf{x}, \mathbf{u})$ ,  $k \in \mathbf{K}$ , must have continuous gradients, which is assumed in this paper. This is usually not a restrictive assumption in practice.

### **ALGORITHM FOR $\mathbf{P}_{3,\text{por}}$**

With one exception, the development of an algorithm for  $\mathbf{P}_{3,\text{por}}$  is essentially parallel to the two-step process described in the previous section. Let  $\bar{\mathbf{x}} = (\mathbf{x}, \mathbf{a}) \in \mathbb{R}^{n+L}$  be the



augmented design vector, where  $\mathbf{x} \in \mathbb{R}^n$  is the original design vector and  $\mathbf{a} = (a_1, \dots, a_L) \in \mathbb{R}^L$  is a vector of  $L$  variables, one for each structure. We define the intermediate optimization problem by

$$\bar{\mathbf{P}}_{3,\text{por}} \min_{(\mathbf{x}, \mathbf{a}) \in \mathbb{R}^{n+L}} \left\{ \sum_{l=1}^L c_0^{(l)}(\mathbf{x}) + \sum_{l=1}^L c^{(l)}(\mathbf{x})a_l \mid p^{(l)}(\mathbf{x}) \leq a_l, 0 \leq a_l \leq \hat{p}^{(l)}, l \in \mathbf{L}, \mathbf{x} \in \mathbf{X} \right\}. \quad (15)$$

The equivalence between  $\mathbf{P}_{3,\text{por}}$  and  $\bar{\mathbf{P}}_{3,\text{por}}$  follows the same arguments as the equivalence between  $\mathbf{P}_3$  and  $\bar{\mathbf{P}}_3$  (see the discussion above and Appendix A).

For any  $\mathbf{t} = (t_1, \dots, t_L) \in \mathbb{R}^L$ , with positive components, we define the approximating problem for  $\bar{\mathbf{P}}_{3,\text{por}}$  and  $\mathbf{P}_{3,\text{por}}$ :

$$\bar{\mathbf{P}}_{3,\text{por},\mathbf{t}} \min_{\bar{\mathbf{x}} = (\mathbf{x}, \mathbf{a}) \in \mathbb{R}^{n+L}} \left\{ \sum_{l=1}^L c_0^{(l)}(\mathbf{x}) + \sum_{l=1}^L c^{(l)}(\mathbf{x})a_l \mid \psi_{t_l}^{(l)}(\bar{\mathbf{x}}) \leq 0, 0 \leq a_l \leq \hat{p}^{(l)}, l \in \mathbf{L}, \mathbf{x} \in \mathbf{X} \right\}, \quad (16)$$

where

$$\psi_{t_l}^{(l)}(\bar{\mathbf{x}}) = \max_{k \in \mathbf{K}_l} \max_{\mathbf{u} \in \mathbb{B}(\mathbf{0}, 1)} \{-g_k^{(l)}(\mathbf{x}, -\Phi^{-1}(a_l)t_l\mathbf{u})\}. \quad (17)$$

It is noted that (17) involves a maximization over all components in the  $l$ -th structure. The relation between  $\bar{\mathbf{P}}_{3,\text{por}}$  and  $\bar{\mathbf{P}}_{3,\text{por},\mathbf{t}}$  is not as straightforward as in the previously discussed case of  $\bar{\mathbf{P}}_3$  and  $\bar{\mathbf{P}}_{3,\mathbf{t}}$ . Consequently, this is the point where we depart from the derivations in the previous section. Here, we rely on the following argument: suppose that the limit-state functions  $g_k^{(l)}(\mathbf{x}, \mathbf{u}), k \in \mathbf{K}_l, l \in \mathbf{L}$ , are affine in their respective second arguments. Then  $\psi_{t_l}^{(l)}(\bar{\mathbf{x}}) \leq 0$  implies that, for design  $\mathbf{x}$ , the limit-state function of the critical component, say  $k'_l$ , of the  $l$ -th structure is at least the distance  $-\Phi^{-1}(a_l)t_l$  away from the origin in the  $\mathbf{u}$ -space and the failure probability of this component  $p_{k'_l}^{(l)}(\mathbf{x}) \leq \Phi(-\Phi^{-1}(a_l)t_l)$ . Hence, when  $t_l = 1$ ,  $p_{k'_l}^{(l)}(\mathbf{x}) \leq a_l$ . This does not guarantee that the constraint  $p^{(l)}(\mathbf{x}) \leq a_l$  is satisfied. However, since the critical component makes the dominant contribution to the system failure probability, design changes are expected to result in similar variations

in  $p_{k_i}^{(l)}(\mathbf{x})$  as in  $p^{(l)}(\mathbf{x})$ . As in the previous section, every feasible design of  $\bar{\mathbf{P}}_{3,\text{por},\mathbf{t}}$  with  $t_l \geq -\sqrt{\chi^{-1}(1 - \hat{p}^{(l)})}/\Phi^{-1}(\hat{p}^{(l)})$  is feasible for  $\mathbf{P}_{3,\text{por}}$  even for nonlinear limit-state functions. Hence,  $p^{(l)}(\mathbf{x}) \leq a_l$  is guaranteed to be satisfied for sufficiently large  $\mathbf{t}$ .

Consequently,  $\bar{\mathbf{P}}_{3,\text{por},\mathbf{t}}$  is a good approximation to  $\bar{\mathbf{P}}_{3,\text{por}}$  for a suitable selection of  $\mathbf{t} = (t_1, \dots, t_L)$ . It is important to note that the design so obtained is an approximate one, even when the limit-state functions are affine in their respective second arguments.

For a given  $\mathbf{t}$ , problem  $\bar{\mathbf{P}}_{3,\text{por},\mathbf{t}}$  can be solved by applying a semi-infinite optimization algorithm. As described above, adjustments in the parameters  $\mathbf{t}$  must be made to satisfy system probability constraints. The following algorithm accomplishes these objectives:

**Algorithm 2. (For  $\mathbf{P}_{3,\text{por}}$ )**

**Data.** Provide an initial design  $\mathbf{x}_0 \in \mathbb{R}^n$  and a sequence of strictly increasing integers  $N_0, N_1, N_3, \dots$

**Step 0.** Set  $i = 0$ ,  $\mathbf{a}_0 = (\hat{p}^{(1)}, \dots, \hat{p}^{(L)})$ ,  $\mathbf{t}_0 = (1, \dots, 1) \in \mathbb{R}^L$ ,  $\bar{\mathbf{x}}_0 = (\mathbf{x}_0, \mathbf{a}_0)$ .

**Step 1.** Set  $\bar{\mathbf{x}}_{i+1} = (\mathbf{x}_{i+1}, \mathbf{a}_{i+1})$  to be the last iterate after  $N_i$  iterations of a semi-infinite optimization algorithm on the problem  $\bar{\mathbf{P}}_{3,\text{por},\mathbf{t}_i}$  with initialization  $\bar{\mathbf{x}}_i$ .

**Step 2.** Compute “appropriate estimates”  $\tilde{p}^{(l)}(\mathbf{x}_{i+1})$  of  $p^{(l)}(\mathbf{x}_{i+1})$  for all  $l \in \mathbf{L}$ .

**Step 3.** For  $l \in \mathbf{L}$ , set

$$(t_l)_{i+1} = \frac{\Phi^{-1}((a_l)_{i+1})}{\Phi^{-1}(\tilde{p}^{(l)}(\mathbf{x}_{i+1}))} (t_l)_i, \quad (19)$$

where  $(a_l)_{i+1}$  is the  $l$ -th component of  $\mathbf{a}_{i+1}$ .

**Step 4.** Replace  $i$  by  $i + 1$  and go to **Step 1**. □

An “appropriate estimate” in Step 2 of Algorithm 2 is essentially the same as an appropriate estimate in Algorithm 1, i.e., an estimate of the system failure probability computed

by a reliability method using the same precision level as used to verify the design with respect to the constraints  $p^{(l)}(\mathbf{x}) \leq \hat{p}^{(l)}$  in  $\mathbf{P}_{3,\text{por}}$ . Algorithm 2 works in a manner similar to Algorithm 1, and the discussion after Algorithm 1 remains valid with appropriate changes in notation.

We cannot guarantee that Algorithms 1 and 2 converge to the true optimal solutions of  $\mathbf{P}_3$  and  $\mathbf{P}_{3,\text{por}}$ , respectively, in general cases. Nevertheless, the designs found by Algorithms 1 and 2 are guaranteed to satisfy structural and reliability constraints, which is of significant practical interest, and, at least for moderately nonlinear limit-state functions, are also expected to be close to locally optimal solutions due to the relation between reliability constraints and corresponding semi-infinite constraints in  $\bar{\mathbf{P}}_{3,t}$  and  $\bar{\mathbf{P}}_{3,\text{por},t}$ .

## NUMERICAL EXAMPLE

Consider a highway bridge with reinforced concrete girders of the type shown in Figures 1 and 2. In this example, we design one such girder using the material and load data from Lin and Frangopol (1996) and Frangopol et al. (1997). The design variables are collected in the vector  $\mathbf{x} = (A_s, b, h_f, b_w, h_w, A_v, S_1, S_2, S_3) \in \mathbb{R}^9$ , where  $A_s$  is the area of the tension steel reinforcement,  $b$  is the width of the flange,  $h_f$  is the thickness of the flange,  $b_w$  is the width of the web,  $h_w$  is the height of the web,  $A_v$  is the area of the shear reinforcement (twice the cross-section area of a stirrup), and  $S_1, S_2$ , and  $S_3$  are the spacings of shear reinforcements in intervals 1, 2, and 3, respectively, see Figure 2.

The random variables describing the loading and material properties are collected in the vector  $\mathbf{V} = (f_y, f'_c, P_D, M_L, P_{S1}, P_{S2}, P_{S3}, W) \in \mathbb{R}^8$ , where  $f_y$  is the yield strength of the reinforcement,  $f'_c$  is the compressive strength of concrete,  $P_D$  is the dead load excluding the weight of the girder,  $M_L$  is the live load bending moment,  $P_{S1}, P_{S2}$  and  $P_{S3}$  are the live load shear forces in intervals 1, 2 and 3, respectively, see Figure 2, and  $W$  is the unit weight of concrete. Following Lin and Frangopol (1996), all the random variables are considered to be independent and normally distributed with the means and c.o.v.'s listed in Table 1. Let the girder length be  $L_g = 18.30$  m, and the distance from the bottom fiber to the centroid

of the tension reinforcement be  $\alpha = 0.1$  m, see Figure 1.

The objective is to design the girder according to the specifications in AASHTO (1992). However, as they stand, these specifications do not lead to well-defined optimization problems for two reasons. First, some of the constraints specified by AASHTO (1992) are not continuous functions, but of the form  $f(\mathbf{x}) \leq 1$  whenever  $h(\mathbf{x}) \leq 0$  and otherwise  $f(\mathbf{x}) \leq 2$ , where  $f(\mathbf{x})$  and  $h(\mathbf{x})$  are continuous functions. Second,  $h(\mathbf{x})$  may also depend on the random variables of the problem. In the following, the first difficulty is overcome by considering different cases. For example, Case 1 has the constraints  $f(\mathbf{x}) \leq 1$  and  $h(\mathbf{x}) \leq 0$ , while Case 2 has the constraints  $f(\mathbf{x}) \leq 2$  and  $h(\mathbf{x}) \geq 0$ . The optimal design for each case is found independently, and the design with the smallest value of the objective function is our solution. The second difficulty is overcome by replacing the random variables in the definition of  $h(\mathbf{x})$  by their mean values. In Appendix B, we define four cases corresponding to the different specifications in AASHTO (1992). To find the optimal design, an optimization problem is solved for each of the four cases.

The girder is assumed to have four failure modes corresponding to the bending moment in the mid span and the shear forces in intervals 1, 2, and 3 (see Figure 2). Each failure mode is represented by a component with an associated limit-state function given by (B.1) and (B.2) in Appendix B. The failure probability of the girder is defined as that of a series system with the four components.

### **Example 1. Design for Minimum Initial Cost**

Suppose that the objective is to minimize a deterministic initial cost of the reinforced concrete girder, while ignoring other costs. The design is subject to the system failure probability constraint  $p(\mathbf{x}) \leq 0.00135$  and the deterministic constraints according to AASHTO (1992) described in Appendix B. This is a design problem of the type  $\mathbf{P}_{3,\text{sys}}$ , as defined in (8), with  $c(\mathbf{x}) = 0$ . Let  $C_s = 50$  and  $C_c = 1$  be the unit costs of the steel reinforcement and concrete per cubic meter, respectively. As in Lin and Frangopol (1996), we define the initial

cost to be

$$c_0(\mathbf{x}) = 0.75C_sL_gA_s + C_s n_S A_v (h_f + h_w - \alpha + 0.5b_w) + C_c L_g (bh_f + b_w h_w), \quad (20)$$

where  $n_S = L_g(1/S_1 + 1/S_2 + 1/S_3)/3$  is the total number of stirrups. In (20), the first term represents the cost of the bending reinforcement. The factor 0.75 appears due to the assumption that the total amount of bending reinforcement is placed only within a length  $L_g/2$  centered at the middle point of the girder, and the remaining part is reinforced with  $0.5A_s$ . The second and third terms in (20) represent the costs of shear reinforcement and concrete, respectively.

We solve  $\mathbf{P}_{3,\text{sys}}$  by using Algorithm 2, with the index  $l$  ignored due to the fact that we are dealing with only one structure. The semi-infinite optimization algorithm described as Algorithm 3.3.2 in Royset et al. (2002), which is originally due to Gonzaga and Polak (1979), is used in Step 1 of Algorithm 2. MCS with 1%-c.o.v. is used to compute the system failure probability in Step 2. Case 1 defined in Appendix B yields the lowest cost, and the optimal design is given in the second column of Table 2, where the design vector  $\mathbf{x}$ , the initial cost, and the system failure probability  $p(\mathbf{x})$  are listed. Some of the entries in Table 2 are not applicable (N/A) to Example 1.

### **Example 2. Design for Minimum Cost**

Suppose that we extend Example 1 by including the expected cost of failure, such that the objective is to minimize the initial cost plus the expected failure cost of the reinforced concrete girder, subject to the same constraints as in Example 1. When the cost of no failure is assumed to be zero, this problem takes the form of  $\mathbf{P}_{3,\text{sys}}$ . Let the cost of failure be  $c(\mathbf{x}) = 500c_0(\mathbf{x})$ . As in Example 1, we solve this problem by using Algorithm 2. Case 1 defined in Appendix B yields the lowest cost, and the result for this case is given in the third column of Table 2. The system failure probability is evaluated using MCS with 1%-c.o.v. Relative to Example 1, a significant increase in the initial cost of the design is observed due

to the consideration of the failure cost. On the other hand, the design failure probability is almost one order of magnitude smaller than that of Example 1.

### Example 3. Design for Minimum Cost of Deteriorating Girder

Suppose that the girder is subject to corrosion of its longitudinal reinforcement. We adopt a corrosion model similar to that used in Frangopol et al. (1997), where the diameter  $D_b(t)$  of a longitudinal reinforcing bar at time  $t$  is given by

$$D_b(t) = \begin{cases} D_{b0} - 2\nu(t - T_I), & t > T_I \\ D_{b0}, & \text{otherwise} \end{cases} \quad (21)$$

where  $D_{b0} = 0.025\text{m}$  denotes the initial diameter,  $\nu$  is the corrosion rate, and  $T_I$  is the corrosion initiation time. The factor 2 in (21) takes into account that the reinforcing bar is subject to corrosion from all sides. We assume  $T_I = A + Bc_a$ , where  $A$  is a lognormal random variable with mean 5 years and c.o.v. equal to 0.20, representing the time it takes to initiate corrosion with a 0.010 m concrete cover,  $B$  is a lognormal random variable with mean 300 years/m and c.o.v. equal to 0.20, representing the additional time it takes to initiate corrosion per meter additional concrete cover, and  $c_a$  is the concrete cover in meters in addition to the 0.010 m minimum cover. The additional concrete cover  $c_a$  is considered a design variable and is included in the design vector  $\mathbf{x}$ , i.e.,  $\mathbf{x} = (A_s, b, h_f, b_w, h_w, A_v, S_1, S_2, S_3, c_a) \in \mathbb{R}^{10}$ . We assume that the corrosion rate  $\nu$  is lognormally distributed with mean  $4.0 \cdot 10^{-5}$  m/years and c.o.v. 0.30. The random variables  $A, B$ , and  $\nu$ , together with the variables in Table 1, are assumed to be statistically independent.

As seen from (21), the area of bending reinforcement is reduced over time. The remaining bending reinforcement area after time  $t$  is  $A'_s(t) = n_b \pi D_b(t)^2 / 4$ , where  $n_b$  is the number of reinforcing bars and  $D_b(t)$  is given in (21). Then, we obtain that  $A'_s(t) = A_s R_c(t)$ , where the reduction factor  $R_c(t) = (1 - 2\nu(t - T_I) / D_{b0})^2$ .

The reinforced concrete girder is now a time-varying structure with  $A_s$  replaced by  $A'_s(t)$  in the four limit-state functions in (B.1) and (B.2). Let  $T_L = 60$  years be the lifetime of the

girder. We assume that the system failure probability in the time interval  $[0, T_L]$  is equal to the point-in-time system failure probability at  $T_L$ , which is reasonable due to the monotone deterioration of the structure. This results in an optimal design problem of the form  $\mathbf{P}_{3,\text{sys}}$ , where  $p(\mathbf{x})$  is the system failure probability at time  $T_L$ , the initial cost is

$$c_0(\mathbf{x}) = 0.75C_sL_gA_s + C_s n_S A_v (h_f + h_w - \alpha + 0.5b_w) + C_c L_g (bh_f + b_w h_w) + C_c L_g b_w c_a, \quad (22)$$

the cost of failure is  $c(\mathbf{x}) = 500c_0(\mathbf{x})$ , and the deterministic constraints are as in Example 1 with two changes. First,  $A_s$  is replaced by  $\bar{A}'_s(T_L) = A_s \bar{R}_c(T_L)$  in the constraint definitions (see Appendix B), where  $\bar{R}_c(T_L)$  is equal to  $R_c(T_L)$  with  $A$ ,  $B$ , and  $\nu$  replaced by their respective mean values. Second, we include the following two additional constraints bounding the new design variable  $c_a$ :

$$c_a - 0.05 \leq 0, \quad (23)$$

$$-c_a \leq 0. \quad (24)$$

The first of these constraints imposes an upper limit of 0.05 m on  $c_a$ . The constraint on the system failure probability remains as in Example 1, i.e.,  $p(\mathbf{x}) \leq 0.00135$ .

We ignore the effect of the small additional load caused by the weight of the additional concrete cover, but include the added cost. As above, we solve  $\mathbf{P}_{3,\text{sys}}$  by using Algorithm 2 with the semi-infinite optimization algorithm described in Royset et al. (2002) and MCS with 1%-c.o.v.. Case 1 defined in Appendix B yields the lowest cost, and the result for this case is given in the fourth column of Table 2. We see from the fourth column of Table 2 that constraint (23) is active, i.e., the use of maximum concrete cover is most cost effective. Relative to Examples 1 and 2, the total expected cost of the design is much higher due to the effect of deterioration in the strength with time.

#### Example 4. Design of Maintenance Plan for the Girder

Suppose that it is decided to maintain the structure in intervals of 20 years, i.e., at 20 and 40 years after its construction. The time of maintenance can be incorporated as a design variable, but in this example we have fixed those times for simplicity. Let  $m_i \in [0, 1]$ ,  $i = 1, 2$ , be two design variables characterizing the maintenance effort at 20 years and 40 years, respectively. Let  $m_i = 0$  denote no maintenance and  $m_i = 1$  denote full maintenance, i.e., restoration to the initial state of the structure. Furthermore, we consider  $m_1$  as the fraction of the aging of the structure from initial construction ( $t = 0$ ) to the first maintenance action ( $t = 20$  years), which is restored to its initial condition. Thus,  $40 - 20m_1$  years is the effective age of the structure before the second maintenance action at  $t = 40$  years. Similarly,  $m_2$  is the fraction of the aging of the structure from initial construction ( $t = 0$  years) to the second maintenance action ( $t = 40$  years), which is mitigated by the second maintenance effort, i.e.,  $20 + (40 - 20m_1)(1 - m_2)$  years is the effective age of the structure at  $t = T_L = 60$  years. We add  $m_1$  and  $m_2$  to the vector of design variables, i.e.,  $\mathbf{x} = (A_s, b, h_f, b_w, h_w, A_v, S_1, S_2, S_3, c_a, m_1, m_2) \in \mathbb{R}^{12}$ .

We ensure the safety of the girder by imposing the constraint  $p(\mathbf{x}) \leq 0.00135$  on the system failure probability over the 60 years lifetime. This probability is obtained as the probability of the union of the failure events during the intervals 0 - 20 years, 20 - 40 years, and 40 - 60 years. For the reasons mentioned earlier, the event of failure within each interval is identical to the failure event at the end of the interval. Thus, the problem is defined as a series system with  $3 \cdot 4 = 12$  limit-state functions. The design is subject to the same deterministic constraints as in Example 3, with the additional constraints

$$m_j - 1 \leq 0, \quad j = 1, 2, \quad (25)$$

$$-m_j \leq 0, \quad j = 1, 2. \quad (26)$$



Furthermore, let the cost of maintenance be

$$c_m(\mathbf{x}) = c_y[20m_1 + (40 - 20m_1)m_2], \quad (27)$$

where  $c_y = 0.15$  represents the cost of complete restoration of the girder after one year's worth of corrosion. Note that the factor in front of  $m_2$  represents the effective age of the structure at 40 years. The initial cost and the cost of failure are as above. Since  $c_m(\mathbf{x})$  does not depend on the failure probability, in formulating the objective function, it is incorporated into  $c_0(\mathbf{x})$ . The problem is solved by applying Algorithm 2 and the result is given in the fifth column of Table 2.

We observe from Table 2 that the expected total cost of the design is smaller for the example with the option of maintenance (Example 4) than for the example without this option (Example 3). Also in the example with maintenance, there is a significant decrease in the initial cost, at the expense of a subsequent maintenance cost. The optimal design suggests a larger maintenance effort at 40 years than at 20 years.

## CONCLUSIONS

Two algorithms are developed for solving a class of optimal structural design problems with component or series system failure probabilities in the objective function and the constraint set definition.

Motivated by a first-order approximation to the failure probability, parameterized approximating problems are constructed that can be solved repeatedly to obtain an approximation to a solution of the original design problem. Higher-order failure probability approximations, e.g., SORM, MCS, can be used by adjusting the parameters of the algorithm. Thus, a significant advantage of the new algorithms is the flexibility in the selection of the method for computing failure probabilities. The approximating problems are semi-infinite optimization problems that can be solved by well-tested and convergent algorithms from the literature.

Numerical examples demonstrate that the new algorithms can be used in design and

maintenance planning and with models involving both time-invariant and time-variant failure probabilities.

The algorithms are derived with careful attention to the underlying assumptions and approximations to ensure a rigorous mathematical foundation. This, together with the fact that any computational reliability method can be employed, makes the algorithms efficient, robust and versatile tools for solving reliability-based optimal structural design problems.

## ACKNOWLEDGEMENTS

Financial support from the Taisei Chair in Civil Engineering at UC Berkeley, the National Science Foundation under grant No. ECS-9900985, and the UC Berkeley Space Sciences Laboratory and Lockheed Martin Advanced Technology Center Mini-grant Program is acknowledged. The authors thank doctoral student Morteza Mahyari for assistance in computing the examples.

## REFERENCES

- Agarwal, H., Renaud, J. E., and Mack, J. D. (2003). “A decomposition approach for reliability-based multidisciplinary design optimization.” *Proceedings of the 44th AIAA/ASME/ASCE/AHS/ASC Structures, Structural Dynamics and Materials (SDM) Conference, Norfolk, VA*.
- American Association of State Highway and Transportation Officials (1992). *Standard specifications for highway bridges*. Washington, D.C. 15th edition.
- Beck, J. L., Chan, E., Irfanoglu, A., and Papadimitriou, C. (1999). “Multi-criteria optimal structural design under uncertainty.” *Earthquake Engineering & Structural Dynamics*, 28(7), 741–761.
- Conn, A. R., Gould, N. I. M., and Toint, P. (1992). *LANCELOT: a Fortran package for large-scale nonlinear optimization (Release A)*. Springer-Verlag, Heidelberg, Germany. Springer Series in Computational Mathematics, Vol. 17.
- Ditlevsen, O. and Madsen, H. O. (1996). *Structural reliability methods*. Wiley, New York, New York.

- Eldred, M. S., Giunta, A. A., Wojtkiewicz, S. F., and Trucano, T. G. (2002). “Formulations for surrogate-based optimization under uncertainty.” *Proceedings of the 9th AIAA/ISSMO Symposium on Multidisciplinary Analysis and Optimization*, Paper AIAA-2002-5585, Atlanta, Georgia.
- Enevoldsen, I. and Sorensen, J. D. (1994). “Reliability-based optimization in structural engineering.” *Structural Safety*, 15(3), 169–196.
- Frangopol, D. M., Lin, K. Y., and Estes, A. C. (1997). “Life-cycle cost design of deteriorating structures.” *J. Structural Engineering*, 123(10), 1390–1401.
- Gasser, M. and Schueller, G. I. (1998). “Some basic principles in reliability-based optimization (RBO) of structures and mechanical components.” *Stochastic programming methods and technical applications*, K. Marti and P. Kall (Eds.), Lecture Notes in Economics and Mathematical Systems 458, Springer-Verlag, Berlin, Germany.
- Gill, P., Murray, W., Saunders, M., and Wright, M. H. (1998). “User’s guide to NPSOL 5.0: A Fortran package for nonlinear programming.” *Report No. SOL-86-1*, System Optimization Laboratory, Stanford University, Stanford, California.
- Gonzaga, C. and Polak, E. (1979). “On constraint dropping schemes and optimality functions for a class of outer approximations algorithms.” *SIAM J. Control and Optimization*, 17(4), 477–493.
- Igusa, T. and Wan, Z. (2003). “Response surface methods for optimization under uncertainty.” *Proceedings of the 9th International Conference on Application of Statistics and Probability*, A. Der Kiureghian, S. Madanat, and J. Pestana (Eds.), San Francisco, California.
- Itoh, Y. and Liu, C. (1999). “Multiobjective optimization of bridge deck maintenance.” *Case Studies in Optimal Design and Maintenance Planning of Civil Infrastructure Systems*, D. M. Frangopol (Ed.), ASCE, Reston, Virginia.
- Kirjner-Neto, C., Polak, E., and Der Kiureghian, A. (1998). “An outer approximations approach to reliability-based optimal design of structures.” *J. Optimization Theory and*

- Application*, 98(1), 1–17.
- Kuschel, N. and Rackwitz, R. (2000). “Optimal design under time-variant reliability constraints.” *Structural Safety*, 22(2), 113–127.
- Lin, K. Y. and Frangopol, D. M. (1996). “Reliability-based optimum design of reinforced concrete girders.” *Structural Safety*, 18(2-3), 239–258.
- Liu, Y. W. and Moses, F. (1992). “Truss optimization including reserve and residual reliability constraints.” *Computers & Structures*, 42(3), 355–363.
- Madsen, H. O. and Friis Hansen, P. (1992). “A comparison of some algorithms for reliability-based structural optimization and sensitivity analysis.” *Reliability and Optimization of Structural Systems, Proceedings IFIP WG 7.5*, R. Rackwitz and P. Thoft-Christensen (Eds.), Springer-Verlag, Berlin, Germany.
- Mahadevan, S. (1992). “Probabilistic optimum design of framed structures.” *Computers & Structures*, 42(3), 365–374.
- Nakamura, H., Miyamoto, A., and Kawamura, K. (2000). “Optimization of bridge maintenance strategies using GA and IA techniques.” *Reliability and Optimization of Structural Systems, Proceedings IFIP WG 7.5*, A. S. Nowak and M. M. Szerszen (Eds.), Ann Arbor, Michigan.
- Polak, E. (1997). *Optimization. Algorithms and consistent approximations*. Springer-Verlag, New York, New York.
- Polak, E., Wets, R. J.-B., and Der Kiureghian, A. (2000). “On the approach to optimization of problems with probabilistic cost and constraints.” *Nonlinear Optimization and Related Topics*, G. Di Pillo and F. Gianessi, (Eds.). 299–316.
- Royset, J. O., Der Kiureghian, A., and Polak, E. (2001a). “Reliability-based optimal design of series structural systems.” *J. Engineering Mechanics*, 127(6), 607–614.
- Royset, J. O., Der Kiureghian, A., and Polak, E. (2001b). “Reliability-based optimal structural design by the decoupling approach.” *J. Reliability Engineering and System Safety*, 73(3), 213–221.

- Royset, J. O., Der Kiureghian, A., and Polak, E. (2002). “Reliability-based design optimization of series structural systems.” *Report No. UCB/SEMM-2002/15*, Department of Civil and Environmental Engineering, University of California, Berkeley, Berkeley, California.
- Royset, J. O., Der Kiureghian, A., and Polak, E. (2004). “Algorithms for reliability-based optimal design.” *AMAS Course on Reliability-Based Design and Optimization, September 2003*, Warsaw, Poland. 177–206.
- Schittkowski, K. (1985). *User’s guide to nonlinear programming code, handbook to optimization program package NLPQL*. University of Stuttgart, Stuttgart, Germany.
- Thoft-Christensen, P. (1991). “On reliability-based structural optimization.” *Reliability and Optimization of Structural Systems, Proceedings of IFIP WG 7.5*, A. Der Kiureghian and P. Thoft-Christensen (Eds.), Lecture Notes in Engineering, Vol. 61, Springer-Verlag, New York, New York.
- Torczon, V. and Trosset, M. W. (1998). “Using approximations to accelerate engineering design optimization.” *Proceedings of the 7th AIAA/USAF/NASA/ISSMO Symp. on Multidisciplinary Analysis and Optimization*, AIAA Paper 98-4800, St. Louis, Missouri.
- Tu, J. and Choi, K. K. (1997). “A performance measure approach in reliability based structural optimization.” *Technical Report 97-02*, Center for Computer-Aided Design, University of Iowa, Iowa City, IA.
- Tu, J., Choi, K. K., and Park, Y. H. (1999). “A new study on reliability-based design optimization.” *ASME Journal of Mechanical Design*, 121, 557–564.

## APPENDIX A. THEOREMS AND PROOFS

Here we present formal statements about the equivalence between  $\mathbf{P}_3$  and  $\bar{\mathbf{P}}_3$ , and between  $\mathbf{P}_{3,\text{por}}$  and  $\bar{\mathbf{P}}_{3,\text{por}}$ .

**Assumption 1.** We assume that

- (i) the cost functions  $c_0(\mathbf{x}), c_k(\mathbf{x}), k \in \mathbf{K}, c_0^{(l)}(\mathbf{x}), c^{(l)}(\mathbf{x}), l \in \mathbf{L}$ , the limit-state functions  $g_k(\mathbf{x}, \mathbf{u}), k \in \mathbf{K}, g_k^{(l)}(\mathbf{x}, \mathbf{u}), k \in \mathbf{K}_l, l \in \mathbf{L}$ , and the deterministic constraint functions

$f_j(\mathbf{x}), j \in \mathbf{q}$ , are continuous,

- (ii)  $M(\{\mathbf{u} \in \mathbb{R}^m \mid g(\mathbf{x}, \mathbf{u}) = 0\}) = 0$  for any limit-state function  $g(\mathbf{x}, \mathbf{u})$  and  $\mathbf{x} \in \mathbf{X}$ , where, for any set  $\mathbf{S} \subset \mathbb{R}^m$ ,  $M(\mathbf{S}) = \int_{\mathbf{S}} \varphi(\mathbf{u}) d\mathbf{u}$ , with  $\varphi(\mathbf{u})$  being the standard multi-variate normal probability density function,
- (iii) the deterministic constraint set  $\mathbf{X}$  is bounded, and
- (iv) the costs  $c_k(\mathbf{x}) > 0$ ,  $k \in \mathbf{K}$ , and  $c^{(l)}(\mathbf{x}) > 0$ ,  $l \in \mathbf{L}$ , for all  $\mathbf{x} \in \mathbf{X}$ . □

Assumption 1(ii), essentially, requires that the interval (for  $m = 1$ ), area (for  $m = 2$ ), volume (for  $m = 3$ ), etc., in which the limit-state function vanishes, has length, area, volume, etc., equal to zero, respectively. This is normally satisfied in realistic design problems.

In the following, for any integer  $d$ ,  $\mathbf{y} \in \mathbb{R}^d$ , and  $\rho > 0$ , we define  $\mathbb{B}(\mathbf{y}, \rho) = \{\mathbf{y}' \in \mathbb{R}^d \mid \|\mathbf{y}' - \mathbf{y}\| \leq \rho\}$ .

**Theorem 1.** *Suppose that Assumption 1 is satisfied. Then,  $\mathbf{P}_3$  and  $\overline{\mathbf{P}}_3$  are equivalent in the following sense:*

- (i) *If  $(\hat{\mathbf{x}}, \hat{\mathbf{a}})$  is a local optimal solution of  $\overline{\mathbf{P}}_3$  with optimal value  $\hat{f}$  and domain of attraction<sup>1</sup>  $\mathbb{B}(\hat{\mathbf{x}}, \hat{\rho}) \times \mathbb{B}(\hat{\mathbf{a}}, \hat{\rho})$ , then there exists a  $\hat{\rho}_0 > 0$  such that  $\hat{\mathbf{x}}$  is a local optimal solution of  $\mathbf{P}_3$  with optimal value  $\hat{f}$  and domain of attraction  $\mathbb{B}(\hat{\mathbf{x}}, \hat{\rho}_0)$ .*
- (ii) *If  $\hat{\mathbf{x}}$  is a local optimal solution of  $\mathbf{P}_3$  with optimal value  $\hat{f}$  and domain of attraction  $\mathbb{B}(\hat{\mathbf{x}}, \hat{\rho})$ , then  $(\hat{\mathbf{x}}, (p_1(\hat{\mathbf{x}}), p_2(\hat{\mathbf{x}}), \dots, p_K(\hat{\mathbf{x}})))$  is a local optimal solution of  $\overline{\mathbf{P}}_3$  with optimal value  $\hat{f}$  and domain of attraction  $\mathbb{B}(\hat{\mathbf{x}}, \hat{\rho}) \times [0, 1]^K$ .*

**Proof.** By Corollary 1 in Polak et al. (2000), Assumption 1(i,ii) implies that  $p_k(\mathbf{x}), k \in \mathbf{K}$ , are continuous functions. This fact and Assumption 1(iii) ensure that  $\mathbf{P}_3$  and  $\overline{\mathbf{P}}_3$  have optimal solutions.

---

<sup>1</sup>A domain were all feasible points have objective values no smaller than the local minimizer.

First, consider (i). Suppose that  $(\hat{\mathbf{x}}, \hat{\mathbf{a}})$  is a local optimal solution of  $\bar{\mathbf{P}}_3$  with domain of attraction  $\mathbb{B}(\hat{\mathbf{x}}, \hat{\rho}) \times \mathbb{B}(\hat{\mathbf{a}}, \hat{\rho})$ . For the sake of a contradiction, suppose that there exists a  $\hat{k} \in \mathbf{K}$  such that  $p_{\hat{k}}(\hat{\mathbf{x}}) < \hat{a}_{\hat{k}}$ . Then, there exists an  $\epsilon > 0$  such that  $p_{\hat{k}}(\hat{\mathbf{x}}) \leq \hat{a}_{\hat{k}} - \epsilon$  and  $(\hat{a}_1, \hat{a}_2, \dots, \hat{a}_{\hat{k}-1}, \hat{a}_{\hat{k}} - \epsilon, \hat{a}_{\hat{k}+1}, \dots, \hat{a}_K) \in \mathbb{B}(\hat{\mathbf{a}}, \hat{\rho})$ . Consequently,  $(\hat{\mathbf{x}}, (\hat{a}_1, \hat{a}_2, \dots, \hat{a}_{\hat{k}-1}, \hat{a}_{\hat{k}} - \epsilon, \hat{a}_{\hat{k}+1}, \dots, \hat{a}_K)) \in \mathbb{B}(\hat{\mathbf{x}}, \hat{\rho}) \times \mathbb{B}(\hat{\mathbf{a}}, \hat{\rho})$ , is feasible for  $\bar{\mathbf{P}}_3$ , and, because  $c_{\hat{k}}(\hat{\mathbf{x}}) > 0$ , has a smaller objective value for  $\bar{\mathbf{P}}_3$  than  $(\hat{\mathbf{x}}, \hat{\mathbf{a}})$ . This contradicts the fact that  $(\hat{\mathbf{x}}, \hat{\mathbf{a}})$  is a local minimum for  $\bar{\mathbf{P}}_3$  and, hence,  $p_k(\hat{\mathbf{x}}) = \hat{a}_k$  for all  $k \in \mathbf{K}$ .

For the sake of another contradiction, suppose that there is no  $\rho > 0$  such that  $\hat{\mathbf{x}}$  is a local optimal solution of  $\mathbf{P}_3$  with domain of attraction  $\mathbb{B}(\hat{\mathbf{x}}, \rho)$ . Then, for all  $\rho > 0$  there must exist a feasible design  $\mathbf{x}_\rho \in \mathbb{B}(\hat{\mathbf{x}}, \rho)$  with lower objective value for  $\mathbf{P}_3$ , i.e.,  $p_k(\mathbf{x}_\rho) \leq \hat{p}_k, k \in \mathbf{K}$ ,  $\mathbf{x}_\rho \in \mathbf{X}$ , and

$$c_0(\mathbf{x}_\rho) + \sum_{k=1}^K c_k(\mathbf{x}_\rho) p_k(\mathbf{x}_\rho) < c_0(\hat{\mathbf{x}}) + \sum_{k=1}^K c_k(\hat{\mathbf{x}}) p_k(\hat{\mathbf{x}}). \quad (\text{A.1})$$

Since  $p_k(\hat{\mathbf{x}}) = \hat{a}_k$  and  $p_k(\mathbf{x})$  is continuous for all  $k \in \mathbf{K}$ , there exists a  $\rho_0 \in (0, \hat{\rho}]$  such that  $(p_1(\mathbf{x}), p_2(\mathbf{x}), \dots, p_K(\mathbf{x})) \in \mathbb{B}(\hat{\mathbf{a}}, \hat{\rho})$  for all  $\mathbf{x} \in \mathbb{B}(\hat{\mathbf{x}}, \rho_0)$ . Now suppose that  $\rho \in (0, \rho_0]$ . Then, the point  $(\mathbf{x}_\rho, (p_1(\mathbf{x}_\rho), p_2(\mathbf{x}_\rho), \dots, p_K(\mathbf{x}_\rho))) \in \mathbb{B}(\hat{\mathbf{x}}, \hat{\rho}) \times \mathbb{B}(\hat{\mathbf{a}}, \hat{\rho})$  and it is also feasible for  $\bar{\mathbf{P}}_3$ . Using (A.1), Assumption 1(iv), and the fact that  $p_k(\hat{\mathbf{x}}) \leq \hat{a}_k$  for all  $k \in \mathbf{K}$ , we see that

$$c_0(\mathbf{x}_\rho) + \sum_{k=1}^K c_k(\mathbf{x}_\rho) p_k(\mathbf{x}_\rho) < c_0(\hat{\mathbf{x}}) + \sum_{k=1}^K c_k(\hat{\mathbf{x}}) p_k(\hat{\mathbf{x}}) \leq c_0(\hat{\mathbf{x}}) + \sum_{k=1}^K c_k(\hat{\mathbf{x}}) \hat{a}_k. \quad (\text{A.2})$$

Hence, the objective value for  $\bar{\mathbf{P}}_3$  is smaller at  $(\mathbf{x}_\rho, (p_1(\mathbf{x}_\rho), p_2(\mathbf{x}_\rho), \dots, p_K(\mathbf{x}_\rho)))$  than at  $(\hat{\mathbf{x}}, \hat{\mathbf{a}})$ , which contradicts the assumption that  $(\hat{\mathbf{x}}, \hat{\mathbf{a}})$  is a local minimum for  $\bar{\mathbf{P}}_3$ . Consequently, there exists a  $\hat{\rho}_0 > 0$  such that  $\hat{\mathbf{x}}$  is a local optimal solution of  $\mathbf{P}_3$  with domain of attraction  $\mathbb{B}(\hat{\mathbf{x}}, \hat{\rho}_0)$ .

Furthermore, since  $p_k(\hat{\mathbf{x}}) = \hat{a}_k$  for all  $k \in \mathbf{K}$ , the objective value for  $\bar{\mathbf{P}}_3$  at  $(\hat{\mathbf{x}}, \hat{\mathbf{a}})$  is  $c_0(\hat{\mathbf{x}}) + \sum_{k \in \mathbf{K}} c_k(\hat{\mathbf{x}}) p_k(\hat{\mathbf{x}})$ , which is identical to the objective value for  $\mathbf{P}_3$  at  $\hat{\mathbf{x}}$ .

Second, consider (ii). Suppose that  $\hat{\mathbf{x}}$  is a local optimal solution of  $\mathbf{P}_3$  with domain of attraction  $\mathbb{B}(\hat{\mathbf{x}}, \hat{\rho})$ . For the sake of a contradiction, suppose that  $(\hat{\mathbf{x}}, (p_1(\hat{\mathbf{x}}), p_2(\hat{\mathbf{x}}), \dots, p_K(\hat{\mathbf{x}})))$

is *not* a local optimal solution of  $\bar{\mathbf{P}}_3$  with domain of attraction  $\mathbb{B}(\hat{\mathbf{x}}, \hat{\rho}) \times [0, 1]^K$ . Then, there must exist another feasible design  $(\mathbf{x}^*, \mathbf{a}^*) \in \mathbb{B}(\hat{\mathbf{x}}, \hat{\rho}) \times [0, 1]^K$  with lower objective value for  $\bar{\mathbf{P}}_3$ , i.e.,  $p_k(\mathbf{x}^*) \leq a_k^*$ ,  $0 \leq a_k^* \leq \hat{\rho}_k$ ,  $k \in \mathbf{K}$ ,  $\mathbf{x}^* \in \mathbf{X}$ , and

$$c_0(\mathbf{x}^*) + \sum_{k=1}^K c_k(\mathbf{x}^*)a_k^* < c_0(\hat{\mathbf{x}}) + \sum_{k=1}^K c_k(\hat{\mathbf{x}})p_k(\hat{\mathbf{x}}). \quad (\text{A.3})$$

The point  $\mathbf{x}^* \in \mathbb{B}(\hat{\mathbf{x}}, \hat{\rho})$  is a feasible point for  $\mathbf{P}_3$ . Using (A.3), Assumption 1(iv), and the fact that  $p_k(\mathbf{x}^*) \leq a_k^*$  for all  $k \in \mathbf{K}$ , we see that

$$c_0(\mathbf{x}^*) + \sum_{k=1}^K c_k(\mathbf{x}^*)p_k(\mathbf{x}^*) \leq c_0(\mathbf{x}^*) + \sum_{k=1}^K c_k(\mathbf{x}^*)a_k^* < c_0(\hat{\mathbf{x}}) + \sum_{k=1}^K c_k(\hat{\mathbf{x}})p_k(\hat{\mathbf{x}}). \quad (\text{A.4})$$

Hence, the objective value for  $\mathbf{P}_3$  is smaller at  $\mathbf{x}^*$  than at  $\hat{\mathbf{x}}$ , which contradicts the assumption that  $\hat{\mathbf{x}}$  is a local minimum for  $\mathbf{P}_3$ . Consequently,  $(\hat{\mathbf{x}}, (p_1(\hat{\mathbf{x}}), p_2(\hat{\mathbf{x}}), \dots, p_K(\hat{\mathbf{x}})))$  is a local optimal solution of  $\bar{\mathbf{P}}_3$  with domain of attraction  $\mathbb{B}(\hat{\mathbf{x}}, \hat{\rho}) \times [0, 1]^K$ . Furthermore, the objective value for  $\mathbf{P}_3$  at  $\hat{\mathbf{x}}$  is identical to the objective value for  $\bar{\mathbf{P}}_3$  at  $(\hat{\mathbf{x}}, (p_1(\hat{\mathbf{x}}), p_2(\hat{\mathbf{x}}), \dots, p_K(\hat{\mathbf{x}})))$ .  $\square$

**Theorem 2.** *Suppose that Assumption 1 is satisfied. Then,  $\mathbf{P}_{3,\text{por}}$  and  $\bar{\mathbf{P}}_{3,\text{por}}$  are equivalent in the following sense:*

- (i) *If  $(\hat{\mathbf{x}}, \hat{\mathbf{a}})$  is a local optimal solution of  $\bar{\mathbf{P}}_{3,\text{por}}$  with optimal value  $\hat{f}$  and domain of attraction  $\mathbb{B}(\hat{\mathbf{x}}, \hat{\rho}) \times \mathbb{B}(\hat{\mathbf{a}}, \hat{\rho})$ , then there exists a  $\hat{\rho}_0 > 0$  such that  $\hat{\mathbf{x}}$  is a local optimal solution of  $\mathbf{P}_{3,\text{por}}$  with optimal value  $\hat{f}$  and domain of attraction  $\mathbb{B}(\hat{\mathbf{x}}, \hat{\rho}_0)$ .*
- (ii) *If  $\hat{\mathbf{x}}$  is a local optimal solution of  $\mathbf{P}_{3,\text{por}}$  with optimal value  $\hat{f}$  and domain of attraction  $\mathbb{B}(\hat{\mathbf{x}}, \hat{\rho})$ , then  $(\hat{\mathbf{x}}, (p^{(1)}(\hat{\mathbf{x}}), p^{(2)}(\hat{\mathbf{x}}), \dots, p^{(L)}(\hat{\mathbf{x}})))$  is a local optimal solution of  $\bar{\mathbf{P}}_{3,\text{por}}$  with optimal value  $\hat{f}$  and domain of attraction  $\mathbb{B}(\hat{\mathbf{x}}, \hat{\rho}) \times [0, 1]^L$ .*

**Proof.** By following a similar argument to the one in Corollary 1 in Polak et al. (2000), Assumption 1(i,ii) can be shown to imply that  $p^{(l)}(\mathbf{x})$ ,  $l \in \mathbf{L}$ , are continuous functions. This fact and Assumption 1(iii) ensure that  $\mathbf{P}_{3,\text{por}}$  and  $\bar{\mathbf{P}}_{3,\text{por}}$  have optimal solutions. The remain-



ing parts of the proof now follows by the same arguments as in Theorem 1.  $\square$

## APPENDIX B. DETAILS ABOUT REINFORCED CONCRETE GIRDER

For the optimal design problem of the reinforced concrete girder to be well-defined, we consider four different cases corresponding to different specifications in AASHTO (1992). Only the first case is presented here in full detail. This is also the case corresponding to the lowest cost in all the examples. The three other cases are described in Royset et al. (2002).

Case 1 corresponds to the situation where the force in the tension reinforcement can be balanced by a compression force in the flange, i.e.,  $0.85f'_c b h_f \geq f_y A_s$ , and the shear capacity in the shear reinforcement is less than or equal to a value related to the cross-section area and the strength of concrete, i.e.,  $A_v f_y / S_1 \leq 4b_w (\gamma f'_c)^{0.5}$ , where  $\gamma = 6.89 \cdot 10^3$  and the variables are given in SI units (i.e., meter, Newton, etc). Hence, these two conditions, with  $f'_c$  and  $f_y$  replaced by their mean values  $\bar{f}_y$  and  $\bar{f}'_c$ , respectively, are imposed as constraints for Case 1 together with other specifications from AASHTO (1992). Consequently, we have the following deterministic constraint functions (all variables in SI units):  $f_1(\mathbf{x}) = -0.85\bar{f}'_c b h_f + \bar{f}_y A_s$ ,  $f_2(\mathbf{x}) = A_v \bar{f}_y / S_1 - 4b_w (\gamma \bar{f}'_c)^{0.5}$ ,  $f_j(\mathbf{x}) = S_{j-2} - A_v \bar{f}_y / (50\gamma b_w)$ ,  $j = 3, 4, 5$ ,  $f_j(\mathbf{x}) = S_{j-5} - (h_f + h_w - \alpha)/2$ ,  $j = 6, 7, 8$ ,  $f_j(\mathbf{x}) = S_{j-8} - 0.6096$ ,  $j = 9, 10, 11$ ,  $f_{12}(\mathbf{x}) = b_w/2 - h_f$ ,  $f_{13}(\mathbf{x}) = b - 4b_w$ ,  $f_{14}(\mathbf{x}) = b_w - b$ ,  $f_{15}(\mathbf{x}) = 1 - A_s/0.001$ ,  $f_{16}(\mathbf{x}) = b - 1.22$ ,  $f_{17}(\mathbf{x}) = 0.15 - h_f$ ,  $f_{18}(\mathbf{x}) = 0.15 - b_w$ ,  $f_{19}(\mathbf{x}) = h_w/b_w - 4$ ,  $f_{20}(\mathbf{x}) = 1 - A_v/0.0001$ ,  $f_{21}(\mathbf{x}) = -h_w$ ,  $f_j(\mathbf{x}) = -S_{j-21}$ ,  $j = 22, 23, 24$ ,  $f_{25}(\mathbf{x}) = h_f + h_w - 1.2$ ,  $f_{26}(\mathbf{x}) = A_v \bar{f}_y / (2\gamma S_3 b_w (\bar{f}'_c / \gamma)^{0.5}) - 4$ ,  $f_{27}(\mathbf{x}) = \rho(\mathbf{x}) - 0.75\rho_b(\mathbf{x})$ , and  $f_{28}(\mathbf{x}) = \rho_0 - \rho(\mathbf{x})$ , where  $\rho(\mathbf{x}) = A_s / (b(h_f + h_w - \alpha))$ ,  $\rho_b(\mathbf{x}) = (0.85^2 \bar{f}'_c / \bar{f}_y) 87000 / (87000 + \bar{f}_y / \gamma)$ , and  $\rho_0 = 200\gamma / \bar{f}_y$ .

These 28 functions define the constraint set  $\mathbf{X}$  (see (7) and (8)) in Examples 1 and 2. In Example 3, the additional constraints (23) and (24) are also included. In Example 4, the additional constraints (23), (24), (25), and (26) are also imposed.

For Examples 1-3, the girder is considered a series structural system with four components

defined as follows: the failure in flexure is specified by the limit-state function

$$G_1(\mathbf{x}, \mathbf{v}) = 1 - \frac{M_L}{\omega(\mathbf{x}, \mathbf{v})} - \frac{P_D L_g^2}{8\omega(\mathbf{x}, \mathbf{v})} - \frac{(bh_f + b_w h_w) W L_g^2}{8\omega(\mathbf{x}, \mathbf{v})}, \quad (B.1)$$

where  $\omega(\mathbf{x}, \mathbf{v}) = A_s f_y (h_f + h_w - \alpha - \eta(\mathbf{x}, \mathbf{v})/2)$  and  $\eta(\mathbf{x}, \mathbf{v}) = A_s f_y / (0.85 f'_c b)$ . Failure in shear in interval  $j \in \{1, 2, 3\}$  is defined by the limit-state functions

$$G_{j+1}(\mathbf{x}, \mathbf{v}) = 1 - \frac{P_{Sj}}{\kappa_j(\mathbf{x}, \mathbf{v})} - \frac{P_D L_g}{6\kappa_j(\mathbf{x}, \mathbf{v})/j} - \frac{(bh_f + b_w h_w) W L_g}{6\kappa_j(\mathbf{x}, \mathbf{v})/j}, \quad (B.2)$$

where  $\kappa_j(\mathbf{x}, \mathbf{v}) = 8.45 b_w (h_f + h_w - \alpha) (f'_c / \gamma)^{0.5} / 0.0254^2 + A_v f_y (h_f + h_w - \alpha) / S_j$ , with all variables in SI units. For Example 4, the four limit-state functions apply in each of three time periods resulting in a series structural system with 12 components. The reader should consult Lin and Frangopol (1996) regarding background information on the above constraints and limit-state functions, which originate from AASHTO (1992) rules.

**List of Tables**

1	Statistics of normal random variables. . . . .	35
2	Optimal design of reinforced concrete girder. . . . .	36

**TABLE 1. Statistics of normal random variables.**

Variable	Description	Mean	c.o.v.
$f_y$	Yield strength of reinforcement	$413.4 \cdot 10^6$ Pa	0.15
$f'_c$	Compressive strength of concrete	$27.56 \cdot 10^6$ Pa	0.15
$P_D$	Dead load excluding girder	$13.57 \cdot 10^3$ N/m	0.20
$M_L$	Live load bending moment	$929 \cdot 10^3$ Nm	0.243
$P_{S1}$	Live load shear in interval 1	$138.31 \cdot 10^3$ N	0.243
$P_{S2}$	Live load shear in interval 2	$183.39 \cdot 10^3$ N	0.243
$P_{S3}$	Live load shear in interval 3	$228.51 \cdot 10^3$ N	0.243
$W$	Unit weight of concrete	$22.74 \cdot 10^3$ N/m <sup>3</sup>	0.10

**TABLE 2. Optimal design of reinforced concrete girder.**

	Example 1	Example 2	Example 3	Example 4
$A_s$	0.00983 m <sup>2</sup>	0.0116 m <sup>2</sup>	0.0161 m <sup>2</sup>	0.0144 m <sup>2</sup>
$b$	0.418 m	0.492 m	0.686 m	0.612 m
$h_f$	0.415 m	0.415 m	0.415 m	0.415 m
$b_w$	0.196 m	0.196 m	0.197 m	0.196 m
$h_w$	0.785 m	0.785 m	0.785 m	0.785 m
$A_v$	0.000186 m <sup>2</sup>	0.000227 m <sup>2</sup>	0.000255 m <sup>2</sup>	0.000255 m <sup>2</sup>
$S_1$	0.508 m	0.502 m	0.549 m	0.550 m
$S_2$	0.224 m	0.226 m	0.246 m	0.247 m
$S_3$	0.140 m	0.142 m	0.154 m	0.155 m
$c_a$	N/A	N/A	0.050 m	0.050 m
$m_1$	N/A	N/A	N/A	0.105
$m_2$	N/A	N/A	N/A	0.243
Initial cost	13.664	15.558	20.434	18.678
Failure cost	N/A	1.459	2.514	1.824
Maintenance cost	N/A	N/A	N/A	1.699
$p(\mathbf{x})$	0.00131	0.000188	0.000246	0.000195
Total expected cost	13.664	17.017	22.948	22.201

**List of Figures**

1	Cross-section of reinforced concrete girder. . . . .	38
2	Reinforced concrete girder with shear reinforcement. . . . .	39

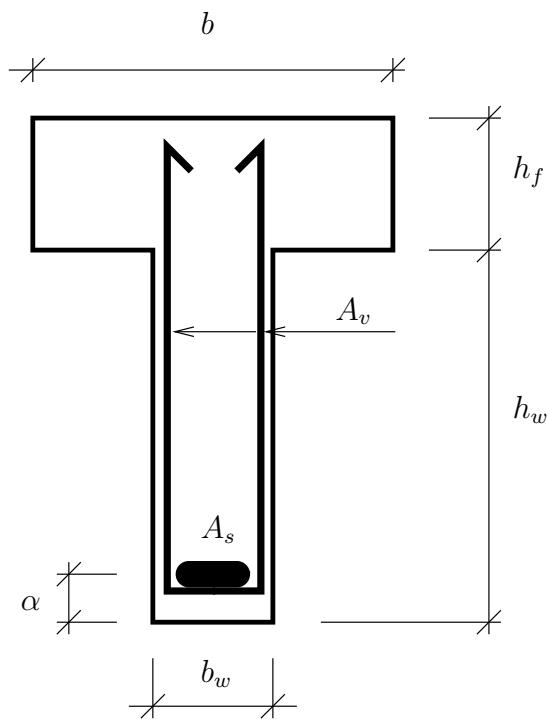

**FIG. 1.** Cross-section of reinforced concrete girder.

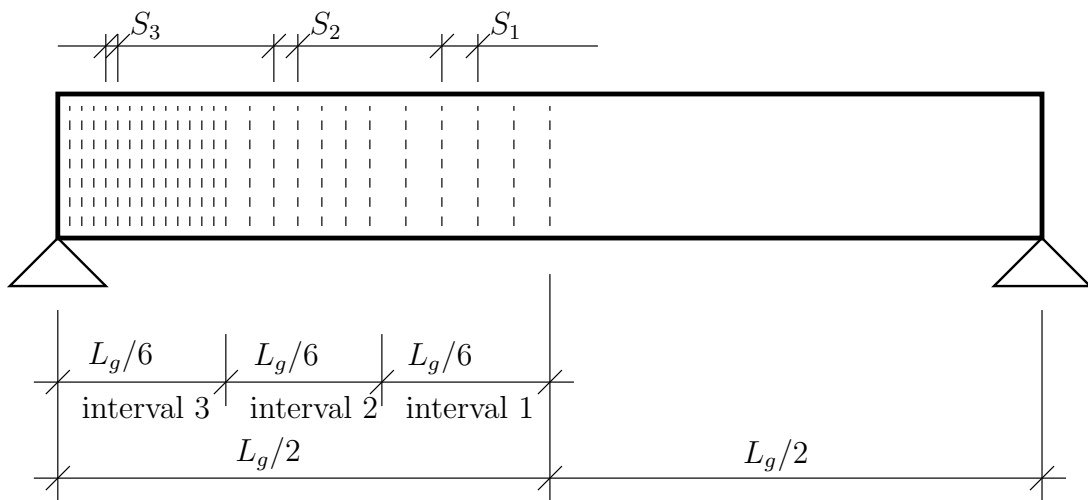

**FIG. 2. Reinforced concrete girder with shear reinforcement.**