

Lawrence Berkeley National Laboratory

Recent Work

Title

ESR SPECTROMETER FOR GASEOUS MEDIA PART 1. PRELIMINARY DESIGN

Permalink

<https://escholarship.org/uc/item/5kn38751>

Author

Lamers, Kenneth W.

Publication Date

1967-10-01

cy. 2

University of California

Ernest O. Lawrence Radiation Laboratory

ESR SPECTROMETER FOR GASEOUS MEDIA
PART I. PRELIMINARY DESIGN

Kenneth W. Lamers

October 1967

TWO-WEEK LOAN COPY

This is a Library Circulating Copy
which may be borrowed for two weeks.
For a personal retention copy, call
Tech. Info. Division, Ext. 5545

Berkeley, California

RECEIVED
LAPPA
UNIVERSITY

LIBRARY AND
DOCUMENTATION

UCRL-17306
cy. 2

DISCLAIMER

This document was prepared as an account of work sponsored by the United States Government. While this document is believed to contain correct information, neither the United States Government nor any agency thereof, nor the Regents of the University of California, nor any of their employees, makes any warranty, express or implied, or assumes any legal responsibility for the accuracy, completeness, or usefulness of any information, apparatus, product, or process disclosed, or represents that its use would not infringe privately owned rights. Reference herein to any specific commercial product, process, or service by its trade name, trademark, manufacturer, or otherwise, does not necessarily constitute or imply its endorsement, recommendation, or favoring by the United States Government or any agency thereof, or the Regents of the University of California. The views and opinions of authors expressed herein do not necessarily state or reflect those of the United States Government or any agency thereof or the Regents of the University of California.

UCRL-17306
UC-37 Instruments
TID-4500 (51th Ed.)

UNIVERSITY OF CALIFORNIA

Lawrence Radiation Laboratory
Berkeley, California

AEC Contract No. W-7405-eng-48

ESR SPECTROMETER FOR GASEOUS MEDIA
PART I. PRELIMINARY DESIGN

Kenneth W. Lamers

October 1967

Printed in the United States of America
Available from
Clearinghouse for Federal Scientific and Technical Information
National Bureau of Standards, U.S. Department of Commerce
Springfield, Virginia 22151
Price: Printed Copy \$3.00; Microfiche \$0.65

Contents

Abstract v

I. Introduction 1

II. Theory of Electron Spin Resonance Absorption 1

III. Design Philosophy

 A. Magnetic Field Strength. 4

 B. Microwave Frequency 4

 C. Cavity Mode 4

 D. Reflection vs Transmission Schemes 4

 E. Detector Choice vs Modulation Frequency 7

IV. System Description 8

V. Theory of Operation

 A. Automatic Frequency Control 11

 B. Spectra Recovery 15

VI. Circuit Description

 A. Automatic Frequency Control Unit

 1. General 16

 2. Lock-In Amplifier, 12 kHz 21

 3. Sweep Amplifier 21

 4. Klystron 21

 B. Signal Channel Control Unit

 1. General 21

 2. Lock-In Amplifier, 560 Hz 21

 3. Frequency Doubler 21

 C. Field Control Unit 21

 D. Axial-Field Power Amplifier 30

VII. Operation

 A. Mode Sweep

 1. Theory of Operation 30

 2. Using the Mode Sweep 34

 B. Automatic Frequency Control

 1. Cavity Resonator Theory 34

 2. Exciting the Cavity at the Correct Mode 42

 3. Locking the Klystron to the Cavity 44

 C. Obtaining a Spectrum 46

 D. Tables of Operating Controls 47

VIII. Maintenance Adjustments

- A. Automatic Frequency Control Unit 46
- B. Signal Channel Control Unit 48

IX. Performance 48

X. Future Considerations 48

Acknowledgments 49

Appendices

- A. Cavity
 - 1. Q Measurements 50
 - 2. Frequency Stability 50
 - 3. Modes 50
 - 4. Coupling Loops 54
 - 5. Magnetic Field Attenuation 54
- B. Klystron
 - 1. Power Output and Frequency vs Reflector Voltage . . . 54
 - 2. Loading Effects 57
 - 3. Frequency vs Klystron Cavity Dial-Setting 57
 - 4. Frequency Drift vs Warmup Time 57
- C. Automatic Frequency Control 59
 - 1. Loop Gain Measurements 59
- D. Helmholtz Coils
 - 1. General 61
 - 2. Field Strength Measurements 61
 - 3. Inductance, Resistance, and Q Measurements 61

References and Footnotes 63

ESR SPECTROMETER FOR GASEOUS MEDIA
PART I. PRELIMINARY DESIGN

Kenneth W. Lamers

Lawrence Radiation Laboratory
University of California
Berkeley, California

October 1967

ABSTRACT

The spectrometer described here is designed to measure the rate of change of very small concentrations of hydrogen atoms. It has not yet been tested with regard to the design objective, and so this report considers design philosophy, operating procedures, and electronic performance only. This report is intended as an instruction manual with design philosophy emphasized in the event that improvements become necessary. Our spectrometer is designed to recover absorption spectra directly, as opposed to the customary derivative. The cavity resonator (1420 MHz) is connected in a transmission scheme that uses barretter detection. The field modulation frequency is 280 Hz; the magnetic field strength is approximately 2 gauss.

I. INTRODUCTION

We plan to measure the rate of change of very small concentrations of hydrogen atoms. Hydrogen gas temperature is 300°C, with the degree of disassociation uncertain. Absolute pressure is 0.5 torr, corresponding to an expected concentration of 10^9 to 10^{13} atoms per cc. The hydrogen is confined to a volume with all dimensions greater than 10 cm in order to reduce surface-effect errors.

We intend to make this measurement with an electron-spin-resonance (ESR) spectrometer.¹ Commercial units are not suitable because: (a) They are designed for liquid samples of very small dimensions. These small dimensions cause surface-effect errors; (b) Our sample is gas, so the spin density is much less than with liquids. The number of spins in the volume provided by most spectrometers would be too small to detect; (c) We wish to examine line widths very much narrower than are usually detected; (d) We prefer to monitor absorption rather than its derivative, and (e) We may operate at 1200°C; the upper limit of most spectrometers is only 300°C. In view of the above, we decided to develop our own spectrometer, increasing sample dimensions to values consistent with the problem. Such a spectrometer offers promise in other experiments involving small concentrations of free radicals.

II. THEORY OF ELECTRON SPIN RESONANCE ABSORPTION

We discuss ESR absorption only enough to convey a physical picture of the mechanism involved and the manner in which the spectrometer must excite that mechanism. Referring to Fig. 1, note that an electron spins about its axis, creating a magnetic field that can be likened to that from a tiny bar magnet. If this spinning electron is subjected to an external magnetic field (H_0) oriented at an angle θ , it experiences a force that acts to decrease the angle θ . The spinning electron resists alignment, however, and precesses at a frequency that is related to its gyromagnetic properties and to the strength of H_0 . If this precessing electron is exposed to a rotating magnetic field at right angles to H_0 (H_1 of Fig. 1), one that rotates at the precession frequency and in the proper sense, the electron flips over, absorbing energy in the process.

Concerning H_1 , we have indicated that it is a rotating field. In practice, it is a linearly oscillating field, but it can be considered to be the resultant of two components that rotate in opposite directions,² as shown in Fig. 2. Only one component rotates in the proper direction for imparting energy to the precessing electron, however, and so the other component can be ignored.

It should be pointed out that H_1 is not always applied at right angles to H_0 . It is sometimes applied parallel to H_0 ,³ as it is in our experiment. The proper direction is dictated by quantum mechanics, and it depends upon the transition to be detected. Physically, H_1 must be in a direction to exert a torque that flips the electron. If $M_F = 0$ ($\theta = 90$ deg), such a torque prevails when H_1 parallels H_0 .

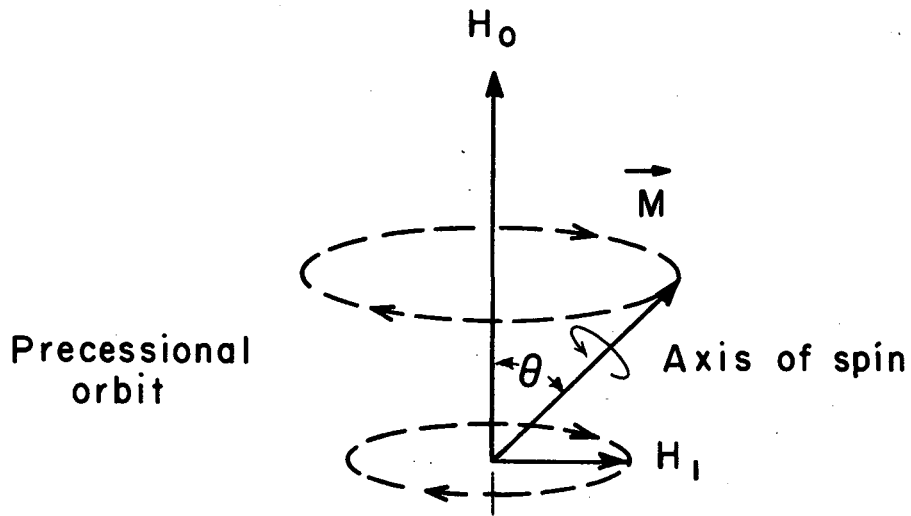

XBL675 - 2980

Fig. 1. Precession of an electron in a magnetic field, H_0 . Absorption occurs if the electron precesses at the frequency of a rotating field, H_1 , applied at right angles to H_0 , as shown.

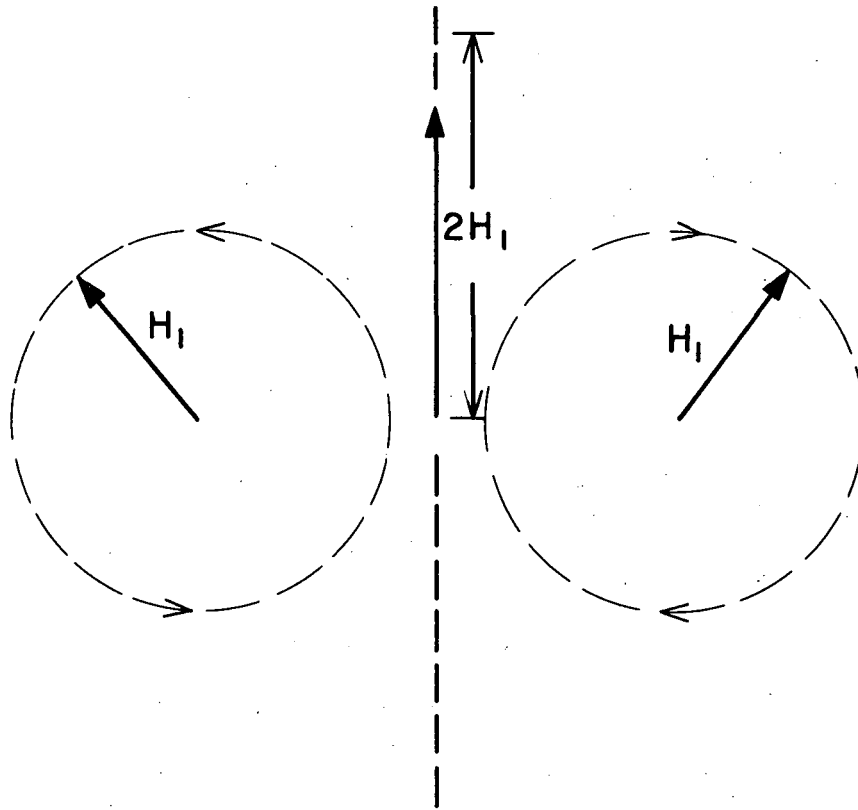

XBL675-2983

Fig. 2. The resolution of a linearly oscillating field into two fields rotating in opposite directions.

III. DESIGN PHILOSOPHY

A. Magnetic Field Strength

If the sample dimensions are large, field homogeneity requirements become stringent. Our spectrometer operates at small field strengths to reduce the absolute gradient resulting from a given percentage nonuniformity. We intend to operate at approximately 2 gauss, as compared with 3000 gauss for many commercial spectrometers. This field is obtained with Helmholtz coils,⁴ and is therefore relatively uniform. Lesser field strengths also reduce magnet-current stabilization requirements. Since regulation and homogeneity requirements are both relaxed, the overall cost of the magnet and its current source can be appreciably less than one of greater field strength.

B. Microwave Frequency

The microwave frequency must match the Larmor (precession) frequency,⁵ which is approximately 6 MHz for a free electron exposed to a 2 gauss field. The electrons to be detected in this experiment are strongly coupled to nuclei, however, which increases their Larmor frequency to approximately 1420 MHz.³

C. Cavity Mode

Since our spectrometer operates at 1420 MHz, it is practical to use a cavity resonator as an absorbing cell. Cavity resonators increase the density of electromagnetic energy by a value proportional to their Q , increasing sensitivity accordingly.⁶ Our cavity, a right circular cylinder, is excited at the TE 0,1,2 mode⁷ because:

- (a) Cavity volume is greater for this mode than for the normal modes.⁸ Assuming that spin density remains constant, a greater volume confines more spins, and therefore improves the signal-to-noise ratio.
- (b) Currents at the cavity walls are circular and in such direction that there is little interchange of current between the cylinder and the end plates (see Fig. 3). This permits us to make the cavity length adjustable without reducing its Q appreciably. An adjustable cavity permits us to accommodate experiments on free radicals such as bromine.
- (c) We can introduce the gas through apertures at either end plate with less field perturbation than would occur with some modes.⁹ Currents at the end plates are circular, and they are not disrupted by a small discontinuity at radii where current density is low.
- (d) The electric field is zero along the cavity axis, which permits us to insert a heating element there with minimum reduction in Q . The heating element would be used for disassociation, but alternative methods are being considered.
- (e) Resonator losses in this mode are very low, which compensates for other losses, such as those due to the adjustable end plate or to an internal heating element.

D. Reflection vs Transmission Schemes

Cavity resonators are usually connected in one of two basic schemes, transmission or reflection⁶ (see Fig. 4). If connected as a transmission

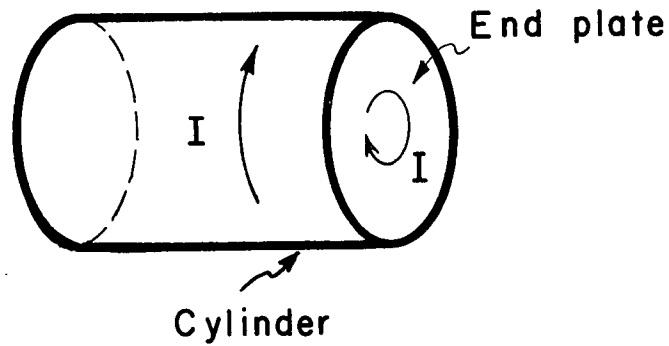

XBL 675-2984

Fig. 3. Cavity resonator, illustrating the direction of circulating currents induced in its walls when excited at the TE $0,1,2$ mode. There is little interchange of current between the cylinder and the two end plates from which the cavity is formed.

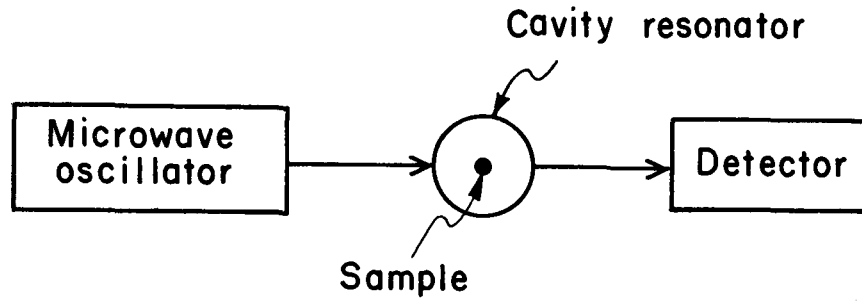

(a) Transmission type

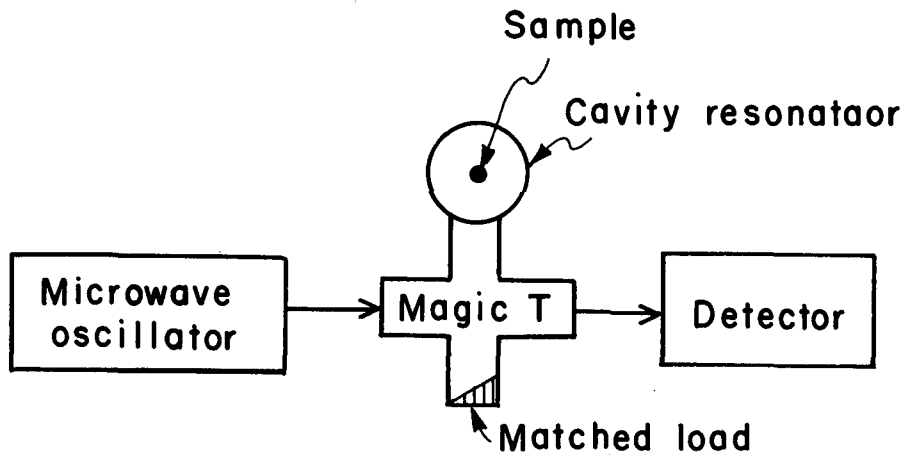

(b) Reflection type

XBL675-2981

Fig. 4. Simplified block diagrams, illustrating the basic differences between transmission and reflection schemes.

resonator, the cavity conducts microwave energy, the amount being modified by sample absorption at resonance. If used as a reflection resonator, the cavity is connected to one leg of a microwave bridge, the bridge being adjusted so that the detector responds to energy reflected from the cavity. Most spectrometers use a reflection scheme because these are generally more sensitive than transmission types; i. e., they can detect fewer spins. We chose a transmission scheme instead because:

(a) We excite the Helmholtz coils with alternating current only (see Sect. V.B). The modulated field resulting induces eddy currents in the cavity walls that attenuate the magnetic field penetrating the cavity. The attenuation is proportional to frequency,¹⁰ which limits the modulation frequency to a low value. When the modulation frequency is low, the sensitivity of transmission schemes using square-law detectors approaches that of reflection schemes using linear detectors.⁶

(b) Transmission schemes do not require a special adjustment to ensure that they respond to the absorption component of susceptibility.¹¹

E. Detector Choice vs Modulation Frequency

Conventional lock-in techniques¹² are used to detect the absorption changes which are generally small in relation to the ambient noise level. Much of this noise is due to microwave amplitude changes. The effect of these changes can be reduced by using field modulation,¹³ a technique applied in our spectrometer.

Assuming field modulation, let us turn our attention to frequency. Some spectrometers modulate at a high frequency (100 kHz typical) in order to minimize $1/f$ noise generated by the crystal detector.¹⁴ If the sample line width is very narrow, different techniques are used. For example, the modulation frequency is reduced (to something less than 1000 Hz) and superheterodyne techniques¹⁵ are used to minimize crystal noise. Another approach involves modulating the microwave energy reflected from the cavity,¹⁶ a technique that permits modulating at a high frequency even though the line width is very narrow (the field cannot be modulated at a high frequency). The latter approach is simpler than superheterodyne schemes, but it is somewhat more complicated than the approach that we now describe.

Our spectrometer uses a barretter detector in lieu of the conventional crystal. Barretters do not exhibit the low-frequency noise common to crystal detectors,¹⁷ and so they permit us to obtain reasonable sensitivity when modulating at a low frequency. Bresler shows⁶ that if the modulating frequency is on the order of hundreds of Hz or less, a transmission scheme using barretter detection (hereafter called transbar) can be more sensitive than a reflection scheme with linear crystal detector (hereafter called reflex). The substance of his article can be summarized as follows.

If one considers detector noise only, both schemes are equally sensitive when the modulation frequency is high (assume 1 MHz). If klystron noise is considered, transbar schemes can be modulated at a lower frequency than can reflex types. Elaborating, square-law detectors are less sensitive to klystron frequency fluctuations than are linear types. With square-law detectors, the limiting factor becomes detector, rather than klystron, noise. Barretter detectors are less noisy than crystal types at low frequencies, and so they permit us to reduce the modulation frequency to a lower value.

Amplitude fluctuations are not a problem with reflex schemes because the microwave bridge cancels them out. Even with transbar schemes, amplitude noise is not appreciably greater than the thermal noise of the barretter, and so it can generally be ignored. If not, a compensation bolometer can be used to cancel it out. Alternatively, the modulation frequency can be increased to 600 Hz or greater (klystron noise is principally low-frequency).

Concerning frequency fluctuations, high-Q cavity resonators translate microwave frequency changes into power changes at the detector. A square-law detector is less sensitive to these changes than is a linear detector, and so the transbar scheme is less responsive to frequency fluctuations.

In summary, most of the noise results from klystron frequency fluctuations, which occur at a slow rate. Transbar schemes are less sensitive to these frequency fluctuations than are reflex schemes, and so they permit us to modulate at a low frequency where detector noise predominates and where barretter detectors are less noisy.

Our modulation frequency is 280 Hz. This frequency was chosen because:

- (a) it is high enough to minimize $1/f$ noise generated by the signal pre-amplifier¹⁸ and to reduce microphonics;¹⁹
- (b) it is remote from 60 Hz and harmonics thereof; and
- (c) eddy currents induced in the cavity walls attenuate the magnetic field less than they would if the frequency were higher.

IV. SYSTEM DESCRIPTION

Basically, our spectrometer consists of a microwave source of energy, a sample gas which absorbs some of that energy when exposed to a magnetic field of proper intensity and direction, and the appropriate detection system. A block diagram of the spectrometer, Fig. 5, reveals that it comprises two principle subsystems, an automatic frequency control and a signal channel.

The automatic frequency control (AFC) locks the klystron's frequency to that of the resonant cavity. This ensures maximum energy transfer between them, and it reduces noise due to microphonics and frequency fluctuations that might mask or distort the spectra sought.

The signal channel responds to microwave energy changes in the cavity that result from sample absorption. This absorption occurs only when the sample is exposed to a magnetic field of the proper strength and direction. The magnetic field of our spectrometer is created by two pairs of Helmholtz coils, one pair mounted axially, the other orthogonally, as shown in Fig. 6. Both pairs are driven by sinusoidally varying currents derived from the 280-Hz reference, but the current exciting one pair differs 90 deg in phase from that exciting the other. This results in a magnetic field of constant amplitude (if not scanning) whose direction can be described by a vector that rotates at 280 Hz. This rotation occurs in a plane that is perpendicular to the orthogonal coils and that passes through the cavity axis. We use this type of field modulation in order to obtain absorption spectra directly, as

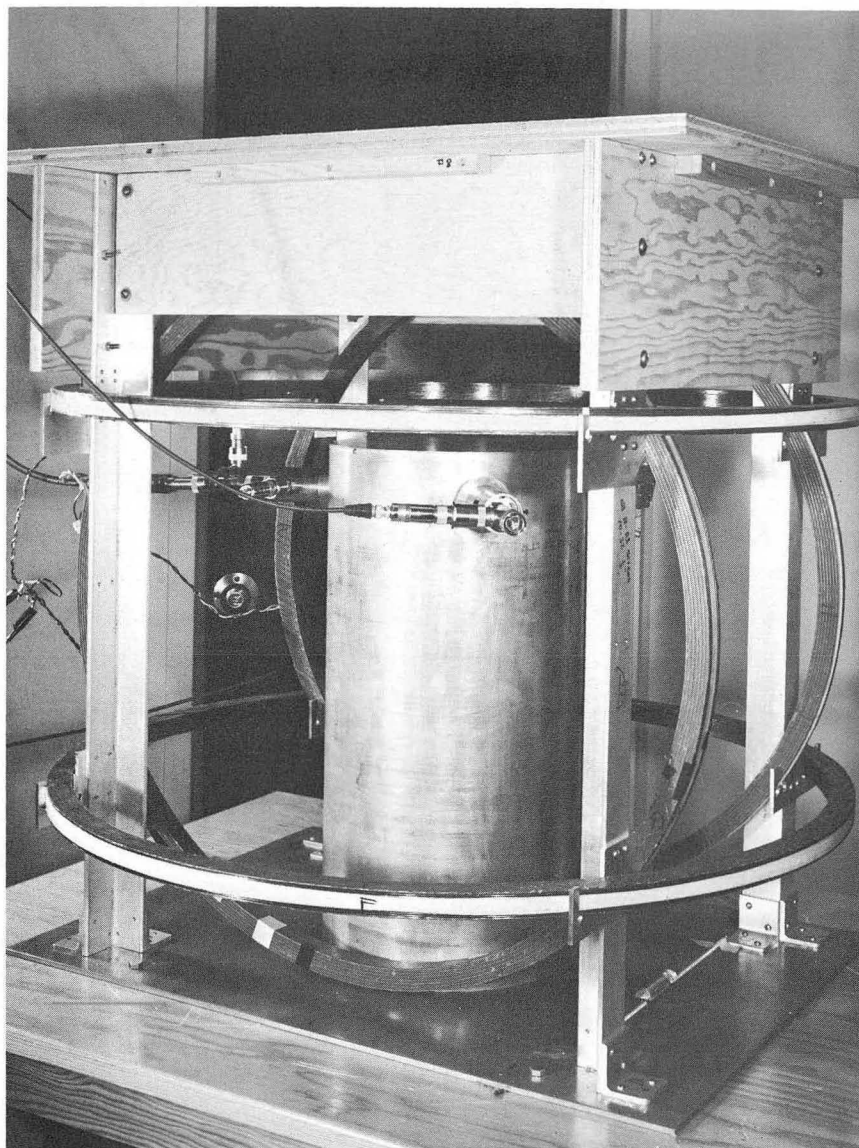

XBB 670-5965

Fig. 6. The Helmholtz coils and their positioning in relation to the cavity. One pair is mounted axially, the other orthogonally, as shown.

discussed in Section V. B. It results in a barretter signal that is twice the modulation frequency, which explains why the signal lock-in amplifier operates at 560 Hz; it also explains the need for a frequency doubler.

When scanning a spectrum, the sinusoidally varying field currents are increased slowly by a motor-driven potentiometer. The H_0 vector rotates just as it does when not scanning, but the magnitude of this vector increases linearly with time.

The cavity (Fig. 7) was formed from a brass cylinder 12.218 in. o. d., 11-15/16 in. i. d., and 24 in. long. The end plates, also brass, are 0.25 in. and 0.5 in. thick for the fixed and adjustable plates, respectively. The cylinder and end plates were silver-plated (0.0004-in. plating -- cost \$ 38), then wiped with a silicone²⁰ that resists corrosion. The cavity is loop-coupled, each loop being attached to a mechanism that permits adjustment of its penetration. Microwave energy is conveyed to the cavity with a coaxial line.²¹ An intervening attenuator²² isolates the klystron from cavity susceptance, reducing the possibility of frequency discontinuities²³ (see Appendix B.2).

The cavity houses a quartz envelope (see Fig. 8) that confines the sample gas to a region where electromagnetic energy density is high, which increases the filling factor²⁴ accordingly. Quartz is used because it offers little attenuation to microwave energy.

V. THEORY OF OPERATION

A. Automatic Frequency Control

As mentioned above, the AFC locks the klystron's frequency to that of the resonant cavity. If either frequency changes (owing to such changes as cavity temperature or klystron drift), the system senses the direction of error and provides a correction voltage to the klystron that brings them back into correspondence. Klystron frequency is continually adjusted to cavity resonance.

Frequency errors are sensed as follows (see Fig. 9). The klystron is frequency-modulated (12 kHz), and so microwave energy accepted by the cavity fluctuates accordingly. Energy within the cavity is detected, producing a 12-kHz error signal with a phase relative to the modulating sinusoid that depends on which side of the cavity resonance peak the klystron is operating on. In essence, the phase of this error signal depends upon the slope of the cavity resonance curve at the frequency about which the klystron swings. If the mean klystron frequency is greater than the resonant frequency of the cavity, the error signal is opposite in phase from that resulting if the klystron frequency is less. The cavity functions as a frequency discriminator, translating microwave frequency errors into a 12-kHz error signal of appropriate phase.

In practice, the klystron is tuned to the peak of the cavity resonance curve so that the error signal is twice the modulating frequency, as shown in Fig. 9(c). The AFC lock-in amplifier does not respond to this second harmonic, however, and its output is zero when the klystron is tuned to the cavity frequency. If the klystron or cavity frequency changes, the AFC lock-in amplifier responds to the error signal, now 12 kHz, producing a

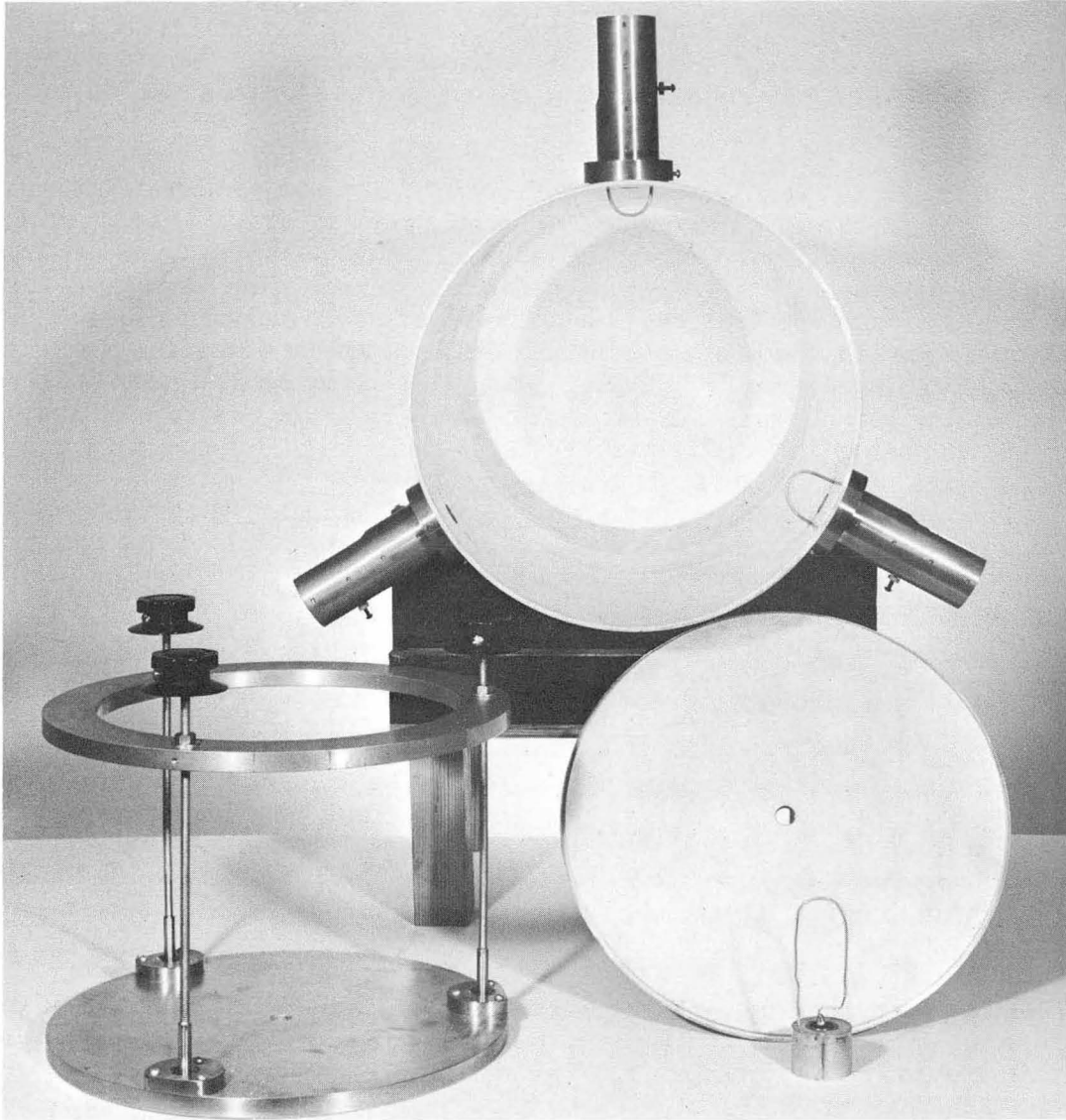

XBB 670-5771

Fig. 7. The cavity resonator, disassembled to reveal (a) the adjustable end plate and its associated mechanism, (b) the fixed end plate, (c) coupling loop location and orientation, and (d) coupling loop mechanism.

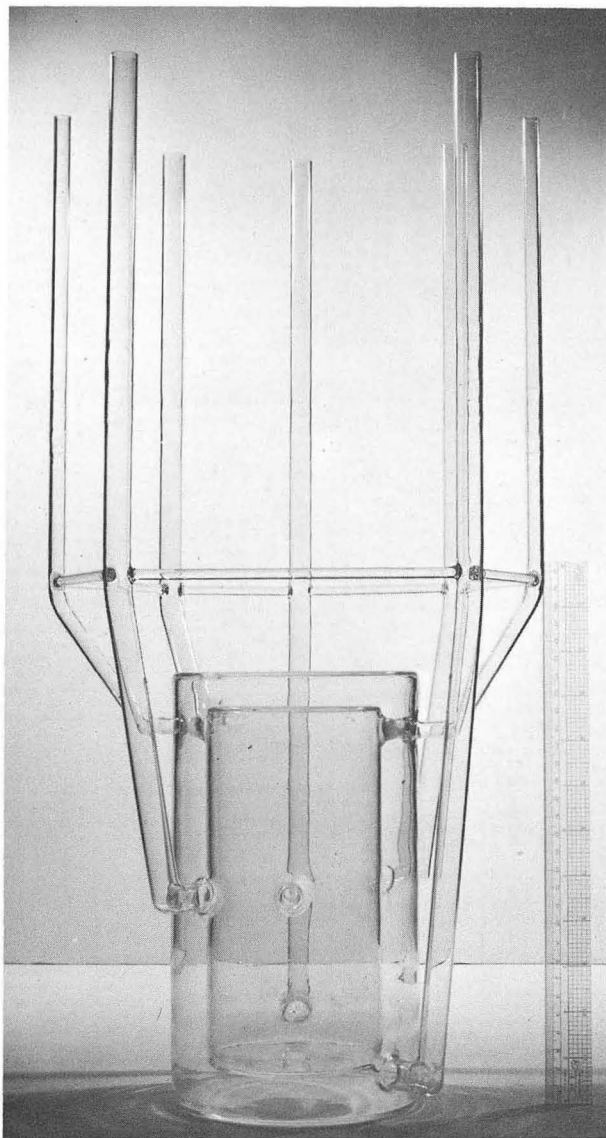

XBB 670-5966

Fig. 8. The reaction cell, a quartz envelope that confines the sample gas to a region where electromagnetic energy density is high.

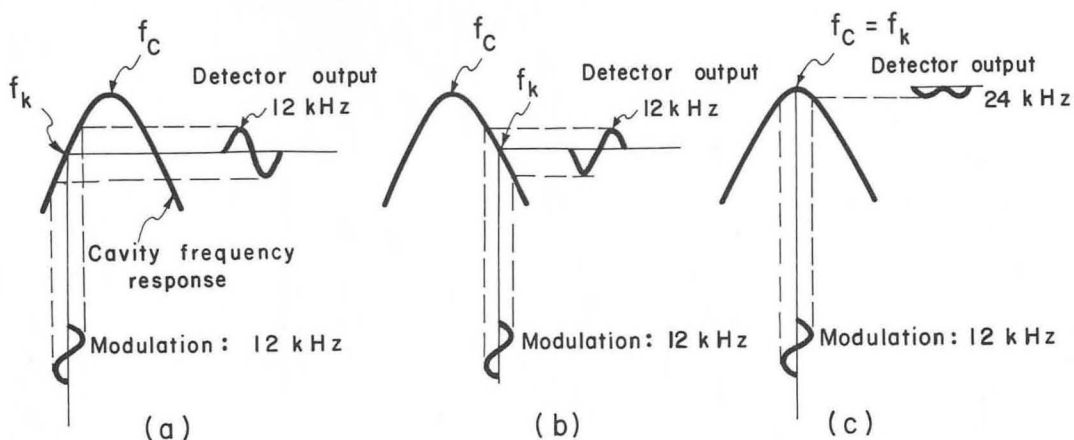

XBL675-2982-A

Fig. 9. The cavity resonator functions as a frequency discriminator, translating microwave frequency errors into an audio-frequency error signal of the appropriate phase. The klystron is frequency-modulated at 12 kHz. (a) mean klystron frequency (f_k) less than the cavity frequency (f_c). Detector output is 12 kHz, the same as the modulating frequency (f_m); (b) $f_k > f_c$, detector output is still 12 kHz, but out of phase with (a); (c) $f_k = f_c$, detector output is 24 kHz ($2 f_m$), the AFC does not respond to this frequency.

corrective voltage that restores the klystron frequency to the resonance peak.

As indicated above, the klystron is modulated at 12 kHz. A high frequency was chosen

- (a) to regulate fast frequency changes;
- (b) to permit a modulation index that concentrates microwave power in the carrier rather than in the sidebands.²⁵ This enhances the authentic absorption signal and reduces the amplitude of spurious responses resulting from sample response to the sideband frequencies;
- (c) because frequency separation between the carrier and its sidebands is directly proportional to the modulating frequency. Spurious responses, if any, are dispersed more if the modulating frequency is increased. Dispersion can preclude the line broadening that results if the sample responds to the carrier and its sidebands collectively; and
- (d) to increase frequency separation between the AFC and signal channels, improving isolation accordingly.

We have indicated that spurious responses can result if the sample absorbs energy from the sidebands created in the process of modulation. The amplitude of these responses can be reduced by adjusting the modulation index to a suitable value.²⁶ Their likelihood can be diminished by modulating at a high frequency so as to increase frequency separation between the carrier and its sidebands. These spurious responses can be eliminated completely by amplitude-modulating microwave energy reflected from the cavity,¹⁶ then combining the sidebands resulting with the carrier to obtain an output signal at the modulating frequency. Since the klystron itself is not modulated, there is no sideband energy within the cavity to which the sample is exposed. This technique is not used here, but it will be considered if spurious responses prove troublesome.

B. Spectra Recovery

As mentioned earlier, lock-in techniques are used to recover the absorption signals, which are generally small in relation to the ambient noise level with which they compete. Lock-in techniques are very effective because they

- (a) minimize noise generated by the amplifying devices used;²⁷
- (b) permit the use of much narrower bandwidths than are usually possible, reducing white noise associated with the signal inversely as the square root of bandwidth (the degree to which bandwidth can be reduced is related to the highest frequency of the information sought); and
- (c) discriminate against noise at the operating frequency but of random phase.

Lock-in techniques minimize noise generated by the amplifying devices used because

- (a) the information sought (signal) is amplitude-modulated to translate its spectra from a band centered around zero frequency to a band centered about a higher frequency (the modulation frequency);²⁸
- (b) most amplifying devices have noise spectra that vary as the reciprocal of frequency;¹² and
- (c) translation to a higher frequency moves the signal to a frequency at which less noise is introduced by the amplifying devices used. In general,

the modulating frequency should be greater than 100 Hz when vacuum-tube amplifiers are used in the early stages of amplification and greater than 1000 Hz when transistor amplifiers are used.

We have just pointed out the advantages of modulating the information sought. We previously indicated that field modulation reduces the effects of microwave amplitude changes. Field modulation, if applied as described in Sec. IV, recreates absorption spectra in lieu of the customary derivative, and we now discuss the reasons why.

Assume, for the moment, that H_0 is not rotating, that H_0 is parallel to H_1 , and that H_0 increases with time. As H_0 increases, the electrons under study precess faster and faster. When their precession frequency approaches that of H_1 , they absorb energy. Suppose that we now substitute a rotating H_0 of equivalent magnitude. The precessing electrons absorb energy as before, but the amount of energy absorbed at any instant is related to the direction of the H_0 vector in relation to the direction of H_1 . Maximum energy is absorbed when they are in alignment; the energy absorbed when they are not is related to $\cos^2\theta$,²⁹ where θ is the angular difference between the vectors representing the instantaneous directions of H_0 and H_1 . The rotating field therefore modulates the absorption, generating a signal with amplitude proportional to that part of the absorption curve being studied. H_0 influences signal amplitude only in the sense that it determines which part of the absorption curve is under scrutiny. Compare this with the case wherein H_0 is amplitude-modulated, generating a signal with amplitude proportional to the slope, or derivative of the absorption line, as illustrated by Fig. 10. In the latter case, signal amplitude is also influenced by the modulation amplitude applied to the magnetic field.

Concerning the need for a frequency doubler to gate the signal channel lock-in amplifier, this can be explained as follows. H_1 reverses direction at the microwave frequency. H_0 , on the other hand, rotates at a relatively slow rate; i. e., 280 Hz. H_0 and H_1 therefore fall into alignment twice for each revolution of H_0 , and so absorption reaches a maximum 560 times per second.

VI. CIRCUIT DESCRIPTION

A. Automatic Frequency Control Unit

1. General

This unit (schematic Fig. 11) comprises the klystron, the 12-kHz lock-in amplifier, a frequency-modulation amplifier, and a sweep amplifier. It also includes the controls for a mode sweep that displays klystron output as a function of reflector voltage. This mode sweep facilitates frequency locking, and it is useful in ascertaining that the klystron operates at maximum output. The frequency-modulation amplifier, driven by reference output from the 12-kHz lock-in amplifier, modulates klystron reflector voltage, thereby providing frequency modulation. This amplifier increases reference output from the lock-in amplifier to a level suitable for generating a mode sweep. The sweep amplifier, also driven by reference output from the 12-kHz lock-in amplifier, furnishes horizontal deflection to the oscilloscope (Lissajous presentation). Construction is illustrated in Figs. 12 and 13.

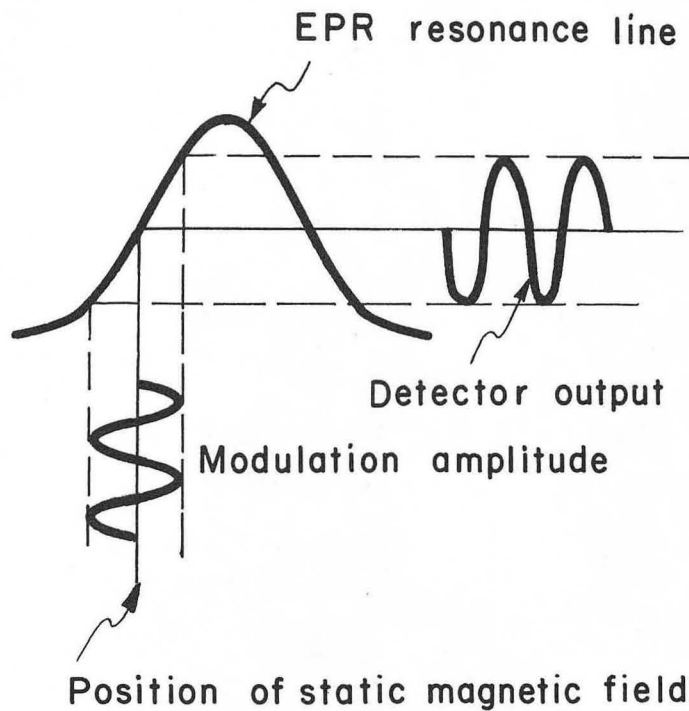

XBL675-2985

Fig. 10. Amplitude modulation of H_0 and phase-sensitive detection yields the derivative of a resonance line. The system responds to the slope of the resonance.

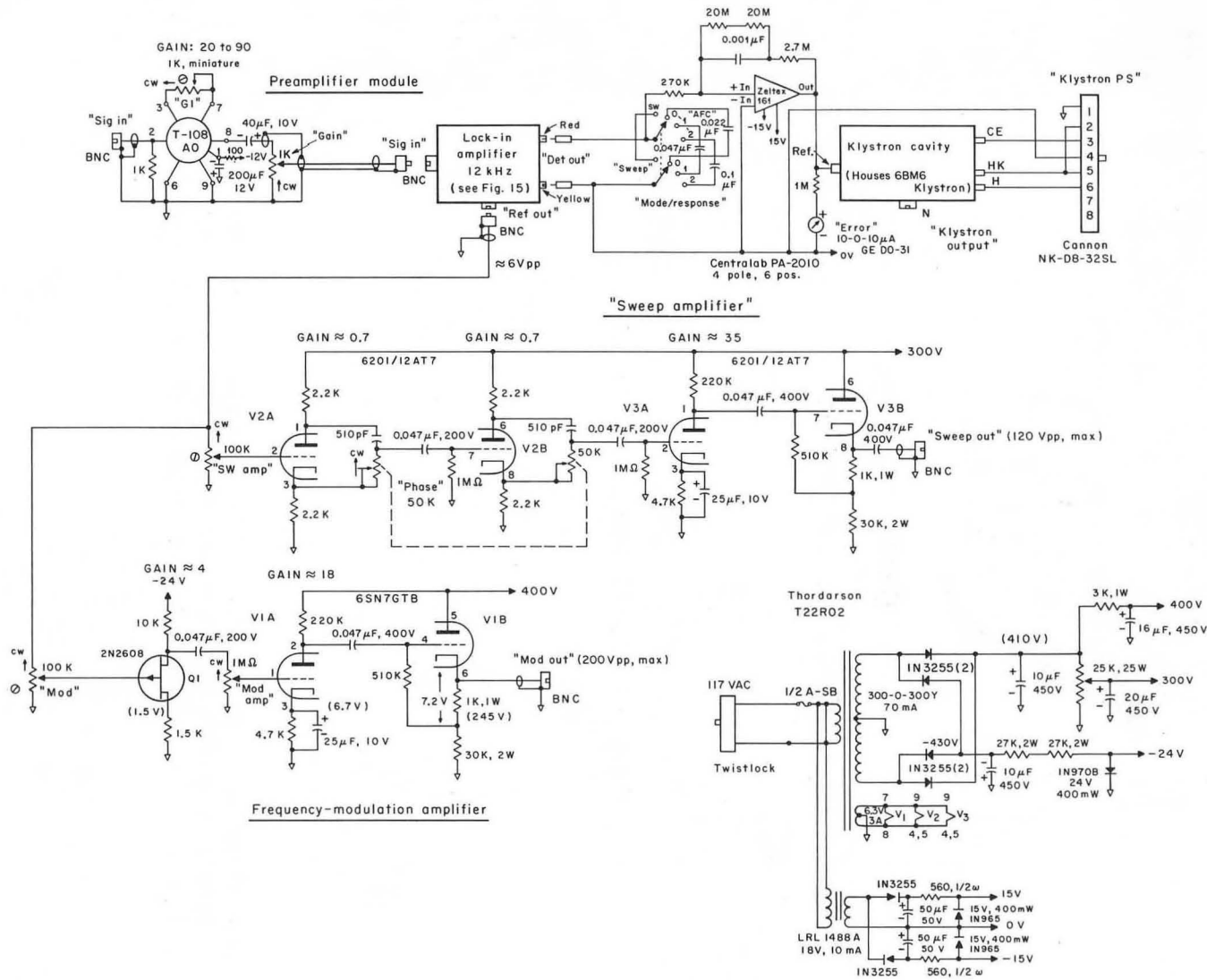

XBL 676-3382-A

Fig. 11. Schematic diagram of the AFC unit. MOD OUT is connected to the klystron power supply (EXT MOD jack); SWEEP OUT furnishes horizontal deflection for an oscilloscope (Lissajous display). All resistors are 0.25 W, 5% carbon, unless indicated otherwise.

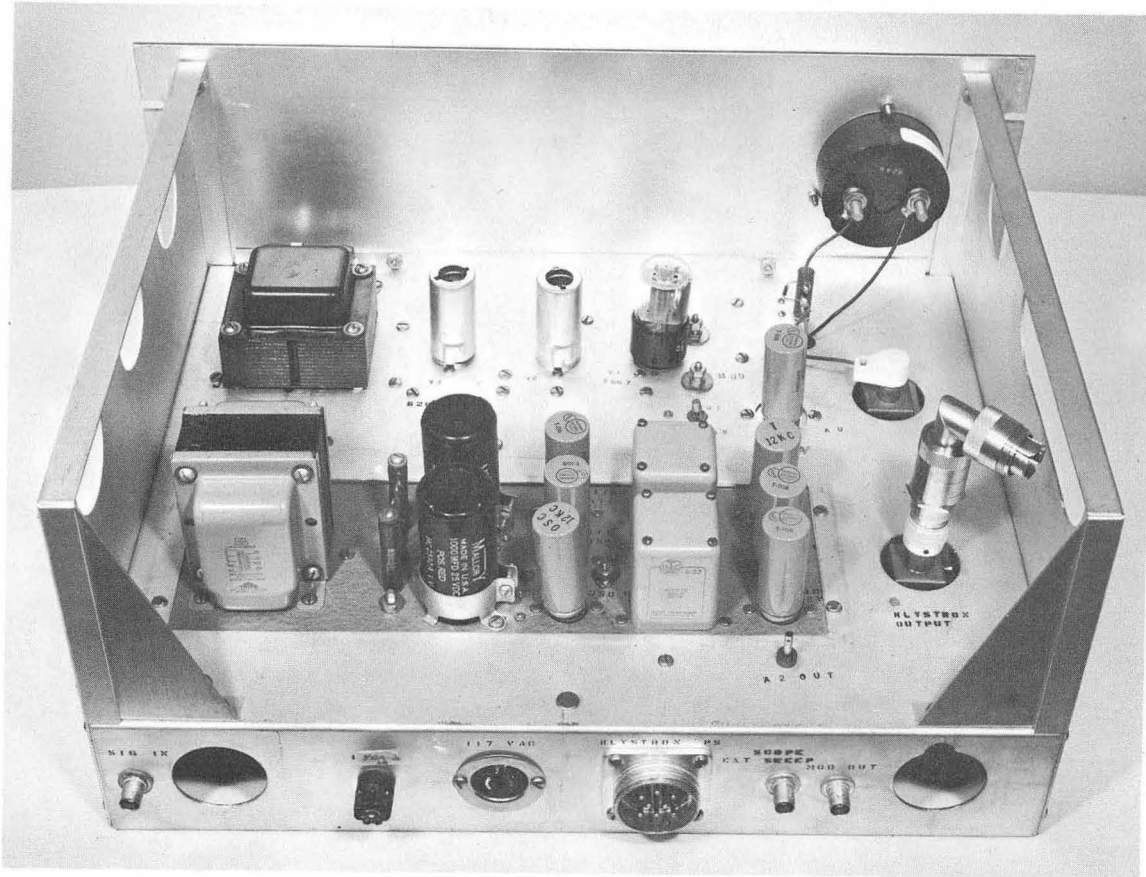

XBB 670-5781

Fig. 12. Automatic frequency control unit. Top rear view, showing the 12-kHz lock-in amplifier in foreground, the preamplifier module (A₀), the sweep and frequency-modulation amplifiers near panel.

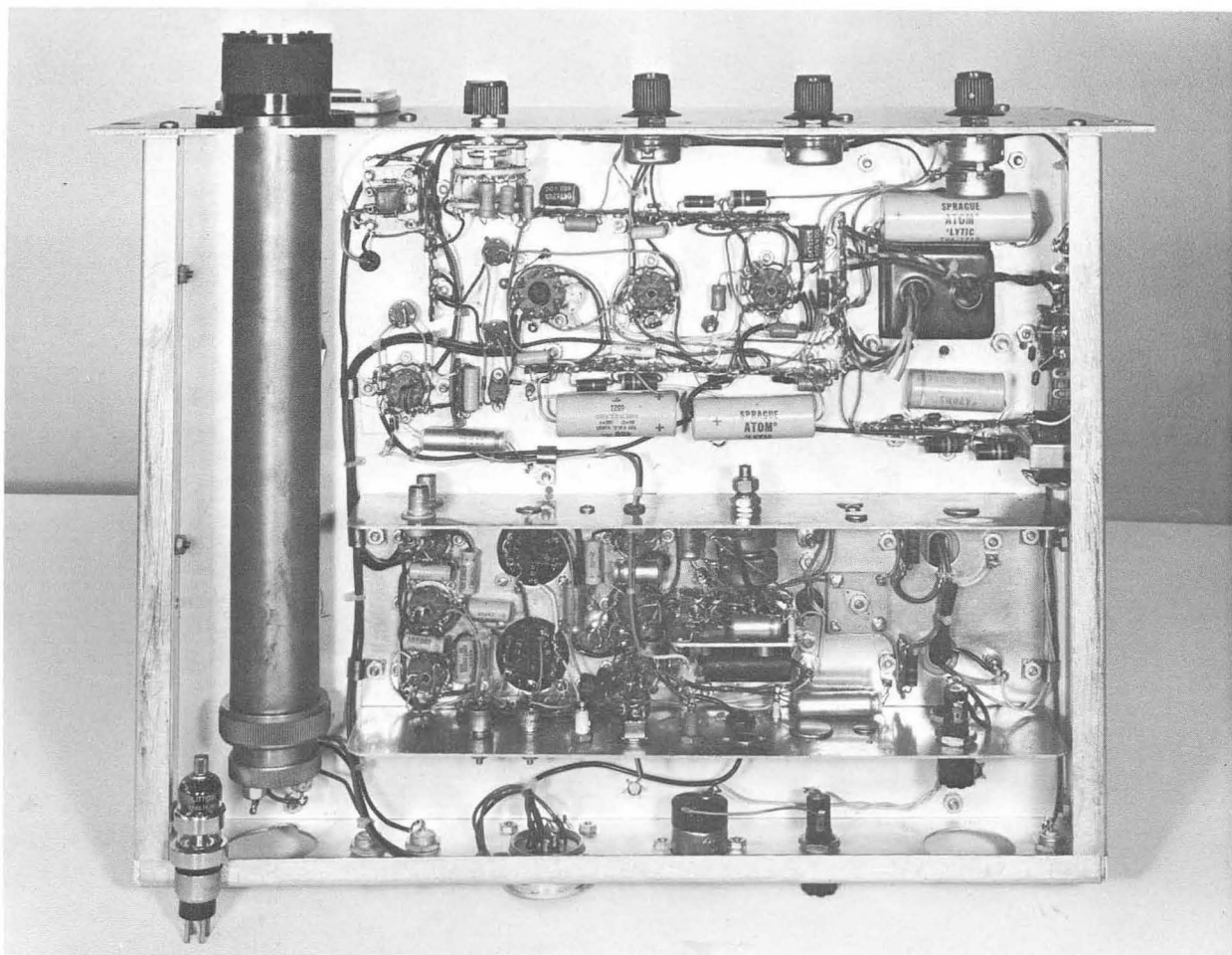

CBB 670-5782

Fig. 13. Automatic Frequency Control Unit. Bottom rear view, showing the klystron cavity at left, the operational amplifier to its right near panel, the frequency-modulation and sweep amplifiers (top). A 6BM6 reflex klystron is shown at lower left.

2. Lock-in Amplifier, 12 kHz

The basic lock-in amplifier has been described in detail,³⁰ so we discuss only those considerations pertinent to AFC. This amplifier was originally designed for operation at 560 Hz. When it was converted to 12 kHz (schematic Fig. 14), the synchronous detector was difficult to balance. This unbalance caused the zero output level to change with setting of the phase control. The problem stemmed from capacity unbalance of transformer T_1 (Fig. 14), the effect being such that each half of the transformer secondary presented a different series impedance when viewed from the gating source. Performance was improved considerably by changing transformer T_1 from UTC type A-19 to A-22. We also substituted an operational amplifier for the source follower and connected its output in series with the klystron reflector voltage supply. Further, we added a small preamplifier module (A_0 , Fig. 11).

3. Sweep Amplifier

This amplifier is conventional except for the phase shifters, which are patterned after those employed in the lock-in amplifier.

4. Klystron

The klystron, reflex type 6BM6, requires an external cavity.³¹ Typical output from the combination (klystron plus external cavity) is approximately 200 mW. Klystron voltages are obtained from a commercial power supply.³²

B. Signal Channel Control Unit

1. General

This unit (schematic Fig. 15) is photographed in Figs. 16 and 17. It includes a lock-in amplifier and a frequency doubler to gate it. It also controls and indicates bolometer current.^{33, 34}

2. Lock-in Amplifier (560 Hz)

Schematic for the signal channel lock-in amplifier is given in Fig. 15. A commercial preamplifier³⁵ will be used to drive it.

3. Frequency Doubler

Frequency doubling (see Fig. 15) is effected with a full-wave rectifier. The rectified output is tuned for purity of waveform.

C. Field Control Unit

This unit (schematic Fig. 18 photographs Figs. 19 and 20) controls the currents to the Helmholtz coils. Both sets of coils, the axial and the orthogonal, are excited by sinusoidal currents of the same frequency (280 Hz), but they are excited 90 deg out of phase. A motor-driven potentiometer³⁶ increases the amplitude of these sinusoidal currents slowly, creating an H_0 field that can be described by a vector that rotates at a uniform rate, but

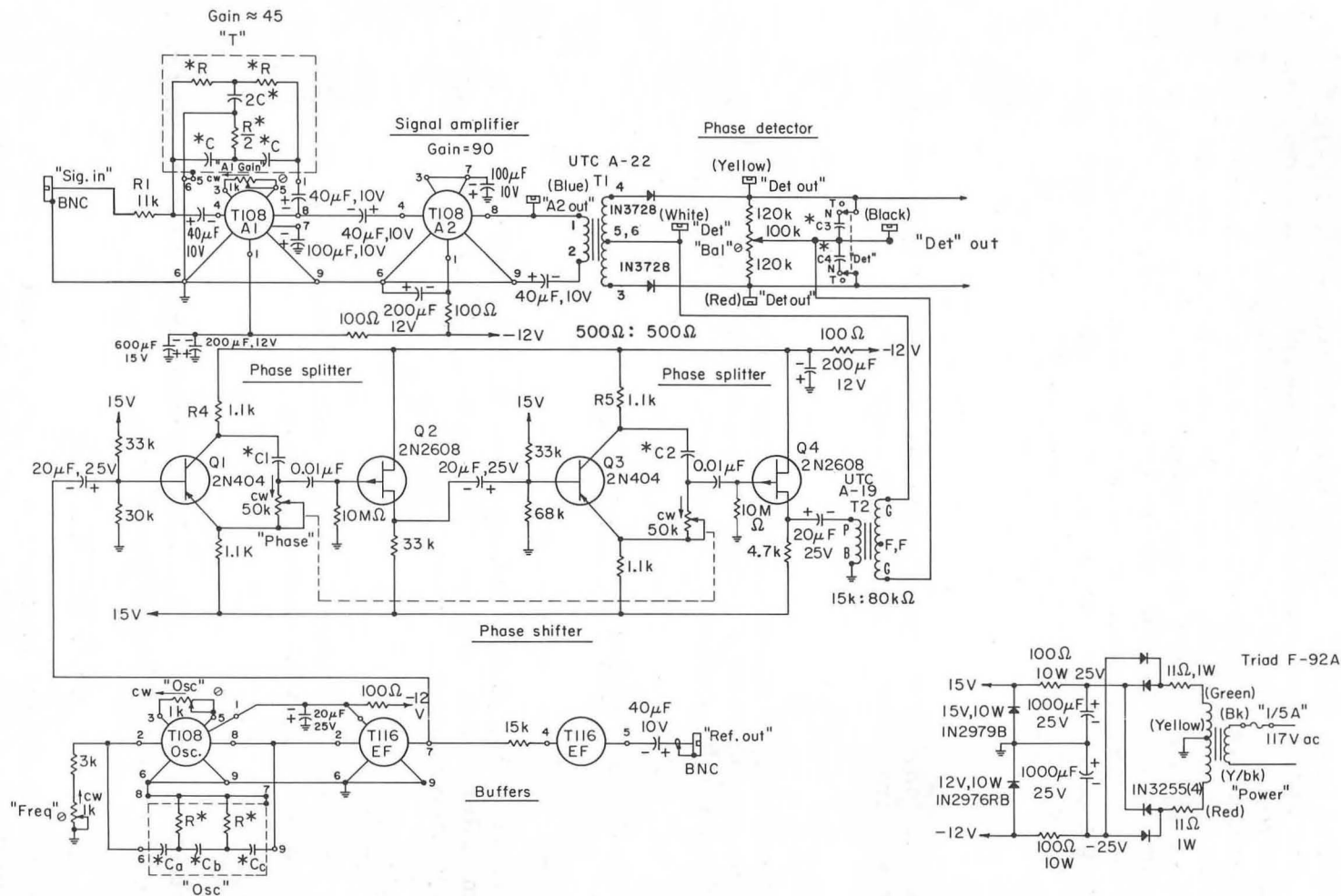

MUB-9585-A

Fig. 14. Schematic diagram for the AFC lock-in amplifier. Components indicated by an * are frequency-sensitive; their values are indicated in Table I. Modules T-108 and T-116 are manufactured by Engineered Electronics Company. All resistors are 0.25 W, 5% carbon, unless indicated otherwise. Phase control is a two-gang 2W Ohmite CCU-5031. All capacitors not polarized are Mylar or mica. BNC connectors are insulated from ground, DAGE 4890-1.

Table I. Values for frequency-sensitive components of Fig. 14 (12-kHz lock-in amplifier).

Component	R (k Ω)	C (μ F)	R/2 (k Ω)	Ca (μ F)	Cb (μ F)	Cc (μ F)
Parallel-T network	3	0.0047	1.5 in parallel with 4.7			
Oscillator network	3.6			0.001 in parallel with 360 pF	0.001 in parallel with 120 pF	0.002
C ₁ and C ₂		3×10^{-4}				
C ₃ and C ₄		5.60×10^{-4}				

Table II. Values for frequency-sensitive components of Fig. 15 (560-Hz lock-in amplifier).

Component	R (k Ω)	C (μ F)	R/2 (k Ω)	Ca (μ F)	Cb (μ F)	Cc (μ F)
Parallel-T network	3	0.100	1.3 in parallel with 15			
Oscillator network	3.6			2×0.033	2×0.033	2×0.033 in parallel with 0.022
C ₁ and C ₂		0.0068 and 0.01 respectively				
C ₃ and C ₄		0.0068				

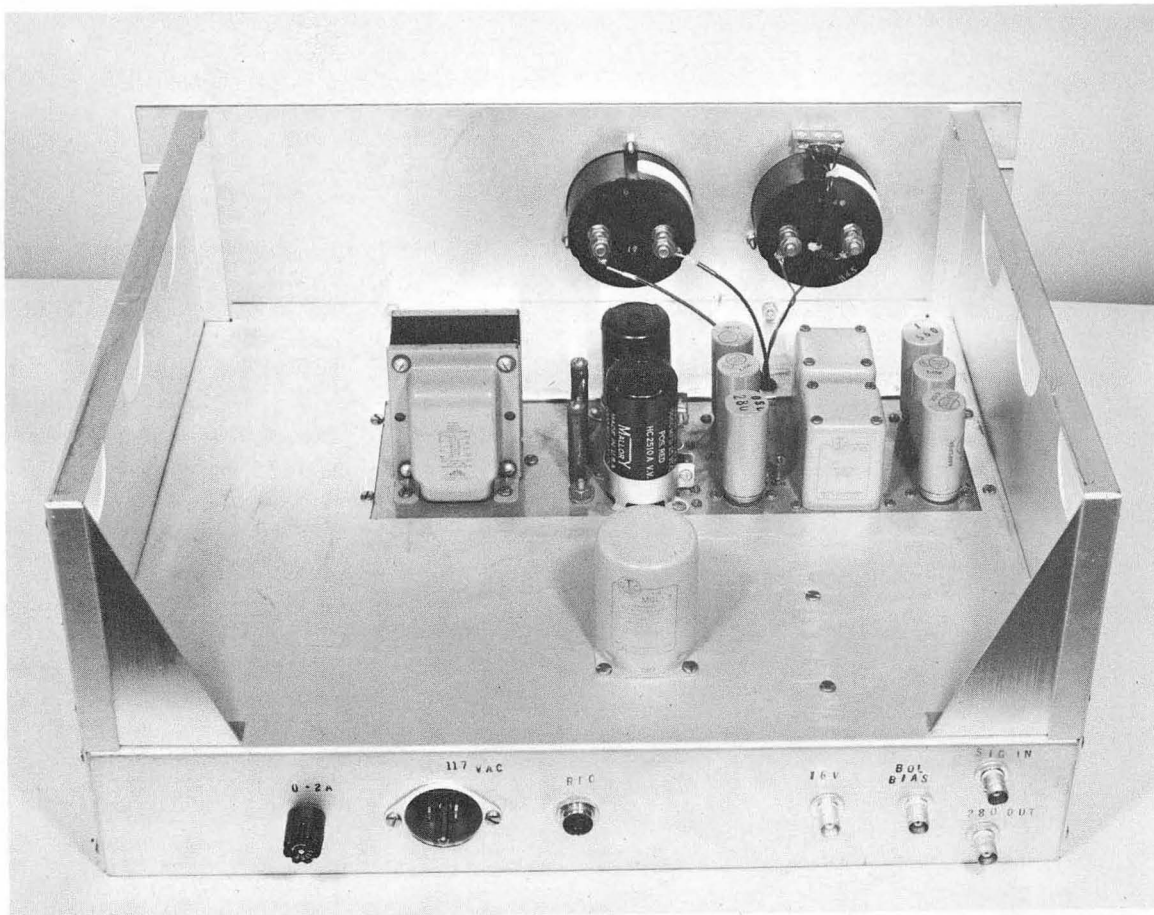

XBB 670-5776

Fig. 16. Signal channel control unit. Top rear view showing the 560-Hz lock-in amplifier (near panel) and the frequency-doubling transformer (foreground).

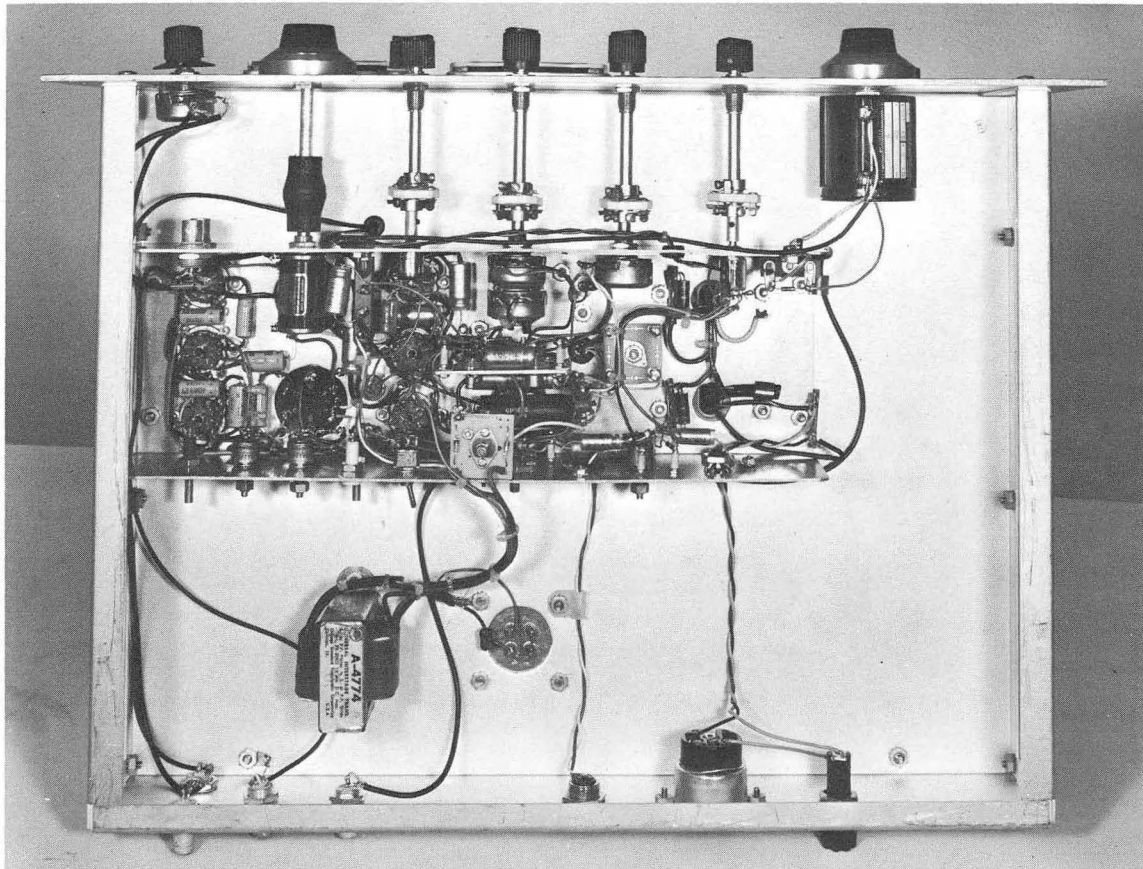

XBB 670-5775

Fig. 17. Signal channel control unit. Bottom rear view showing the 560-Hz lock-in amplifier.

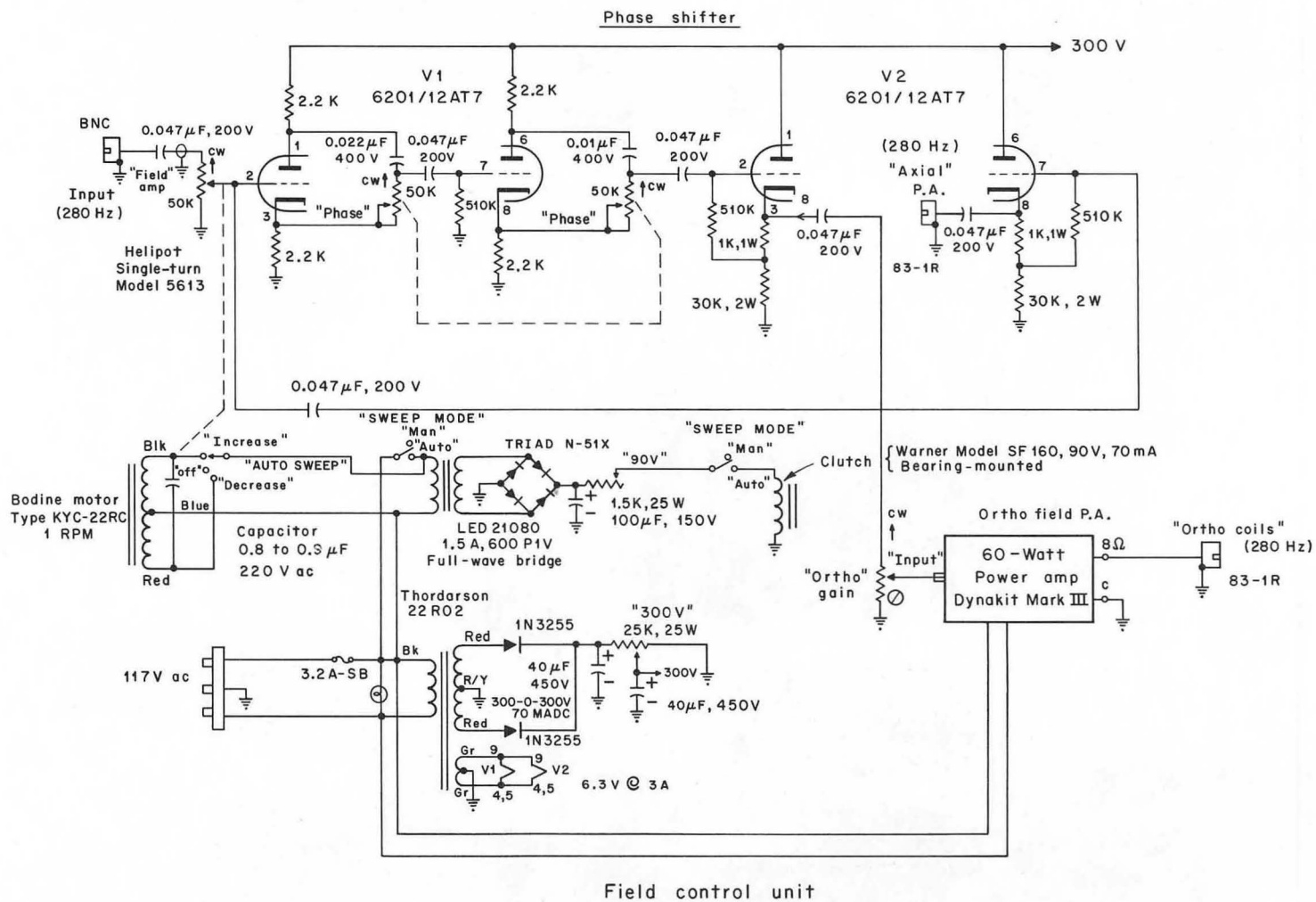

XBL6710-5327

Fig. 18. Schematic diagram for the field control unit. All resistors are 0.25 W, 5% carbon, unless indicated otherwise. A capacitor must be added in series with the amplifier output--it tunes out the reactive component of the Helmholtz coils.

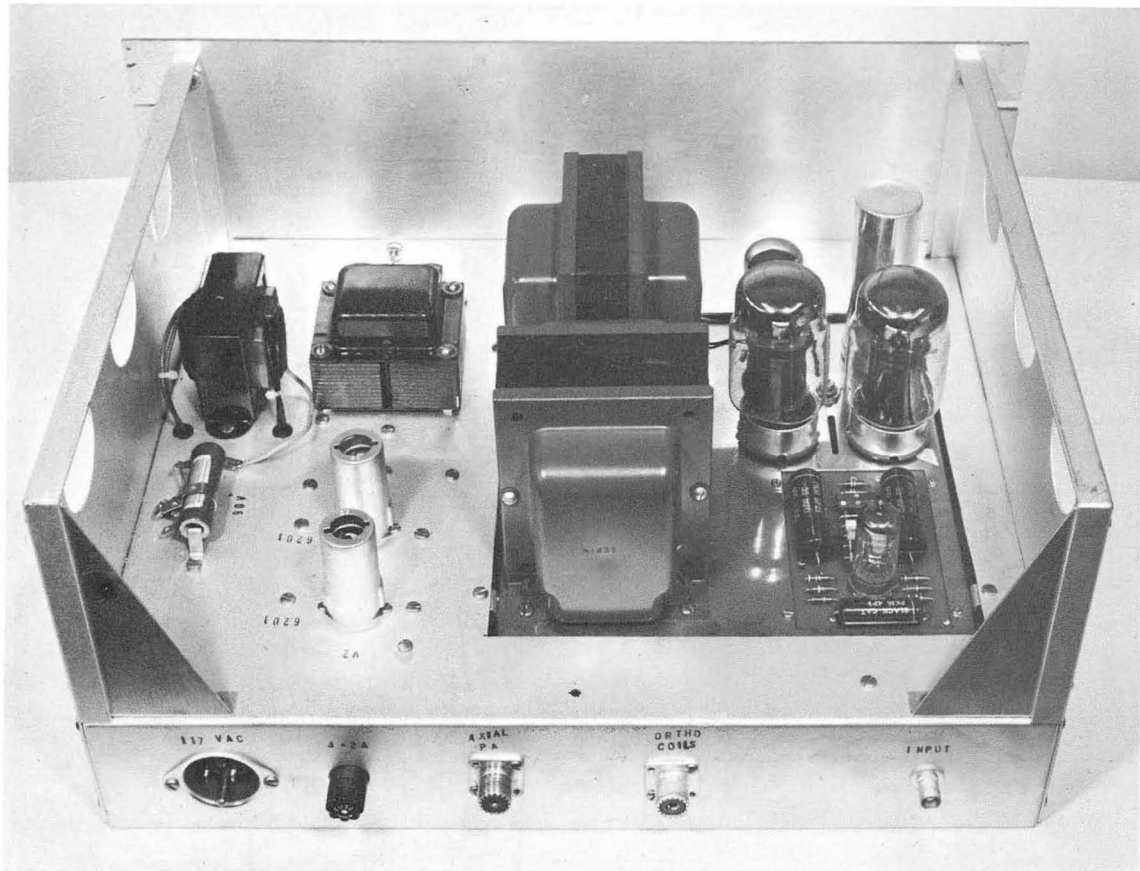

XBB 670-5779

Fig. 19. Field control unit. Top rear view, showing the ortho-field power amplifier (right), the phase shifter and its power supply (left).

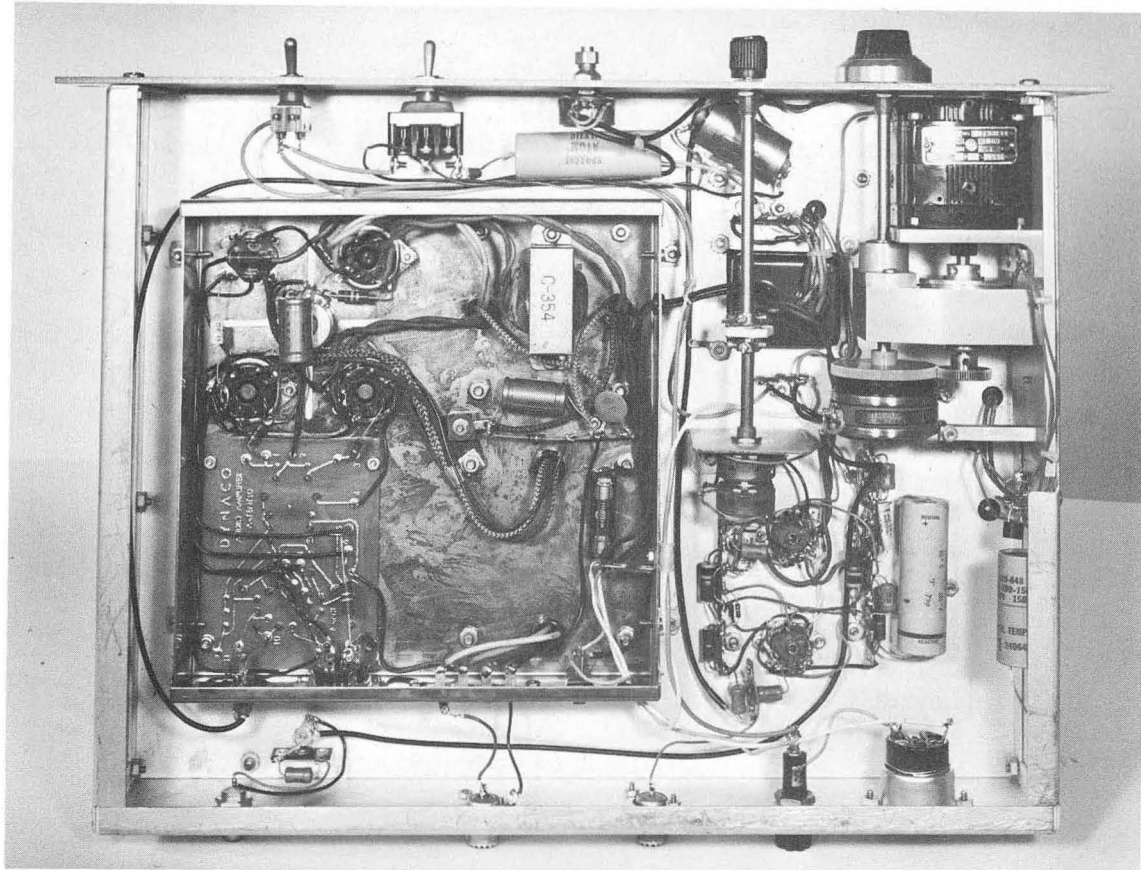

XBB 670-5777

Fig. 20. Field control unit. Bottom rear view, showing the ortho-field power amplifier (left) and the motor-driven potentiometer (right).

with a magnitude that increases linearly with time.

Two sweep modes are available, AUTO and MANUAL. When the scan is set for AUTO, an electrically-operated clutch engages, connecting the current-determining potentiometer to the drive motor. When the scan is set for MANUAL, the clutch is deenergized, which permits us to set the potentiometer (FIELD AMP control) manually.

The unit includes a commercial power amplifier³⁷ (schematic Fig. 21) to drive the orthogonal coils (the axial coils are driven by an identical amplifier mounted separately). The coils were designed to have a resistive component that matches the output impedance of the amplifier; their reactive component is tuned out with a series capacitor.

D. Axial-Field Power Amplifier

This amplifier is identical to that employed in the field control unit. Axial-coil inductance is different from that of the orthogonal coils, and so the resonating capacitor must be selected accordingly.

VII. OPERATION

Note: These operating instructions are interspersed with sections on theory so that the operator can visualize what he is doing rather than performing a number of meaningless adjustments. Once the relevant theory is understood, the operator can bypass the theoretical sections.

A. Mode Sweep

1. Theory of Operation

As discussed earlier, the spectrometer includes a mode sweep that facilitates frequency locking. An idealized sweep, illustrated in Fig. 22, shows klystron output as a function of reflector voltage. Output reaches a maximum at some voltage (V_0), then falls off, dropping to zero as shown (V_1 and V_2). Figure 22 reveals that the klystron oscillates only if the reflector voltage lies between certain limits, and that power output is greatest in the vicinity of V_0 . The actual values of V_0 , V_1 , and V_2 depend upon voltages applied to the other klystron electrodes, but typical values are listed in Appendix B.1.

Referring again to Fig. 22: each reflector voltage within the range of oscillation corresponds to some frequency, the value of which depends upon the setting of the KLYSTRON CAVITY control. If the reflector is swept over a range of voltages, the klystron sweeps over a band of frequencies determined by the KLYSTRON CAVITY setting.

It should be pointed out that reflex klystrons can operate in several modes.³⁸ This is shown in Fig. 23, which shows klystron output if the reflector voltage is changed over wider limits than shown in Fig. 22. The frequencies swept by each mode are somewhat the same, but klystron output is greater for some modes than for others. Most spectrometers (including

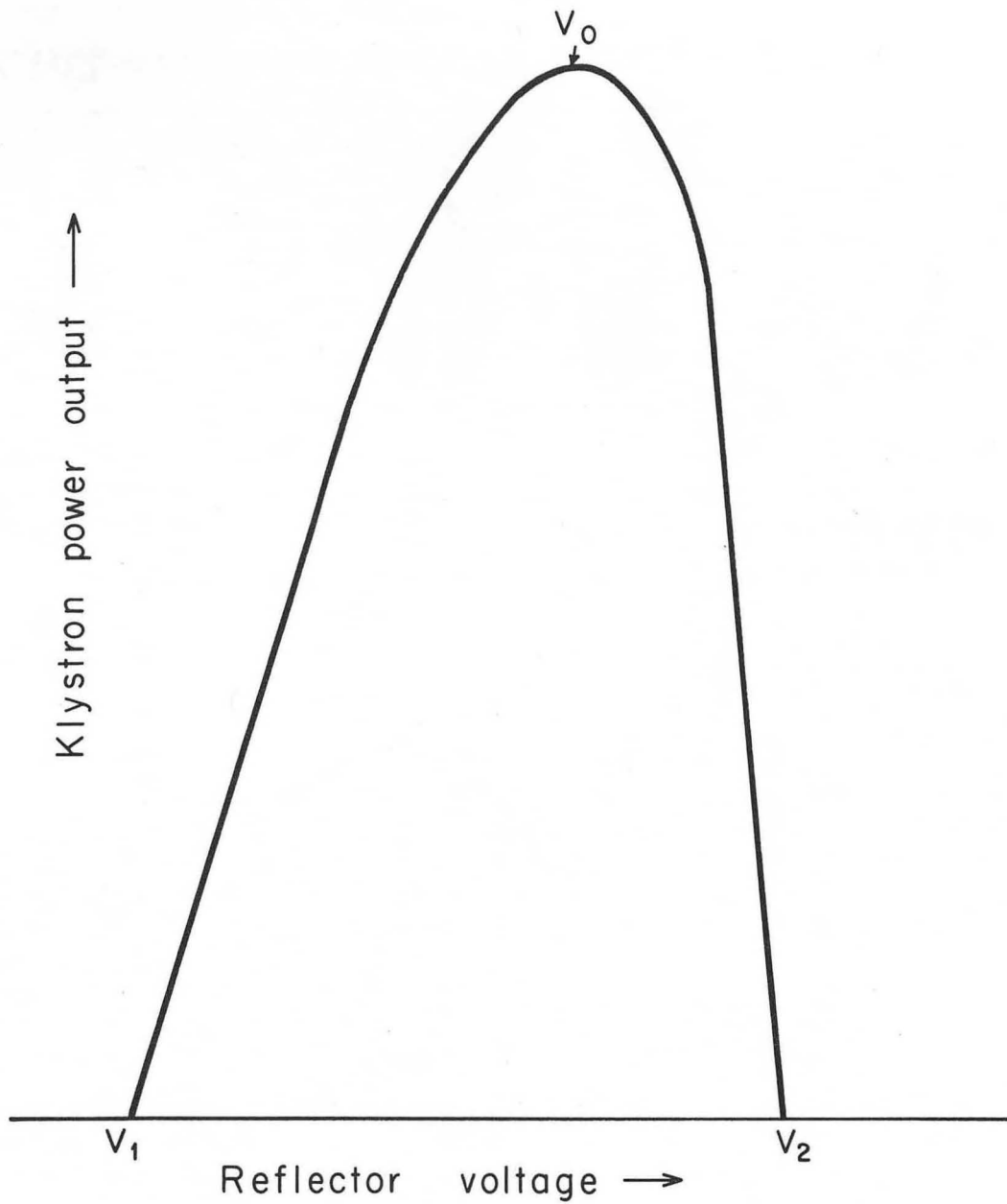

XBL675 - 2986

Fig. 22. An idealized mode sweep showing klystron power output as a function of reflector voltage. The klystron oscillates only if the reflector voltage lies between certain limits. Each reflector voltage within the range of oscillation corresponds to some frequency, the value of which depends upon the setting of the KLYSTRON CAVITY control.

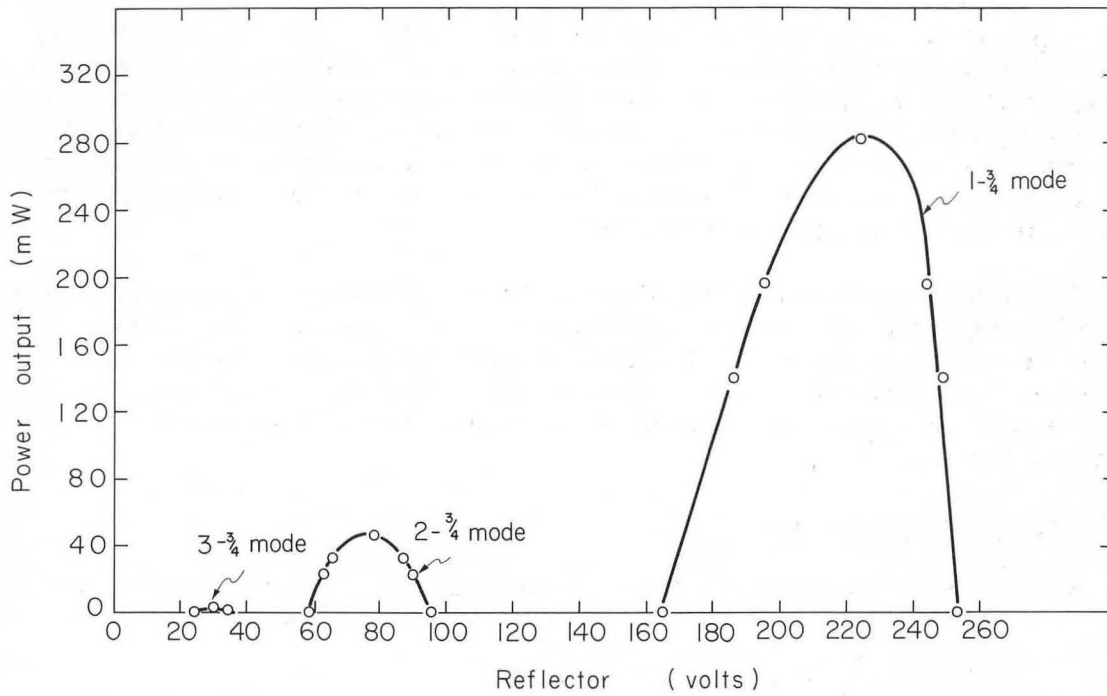

XBL675-2989

Fig. 23. Klystron power output versus reflector voltage for the principal reflector modes.

ours) operate at the mode for which klystron output is greatest.

Referring again to Fig. 23: note that our klystron can oscillate in any one of three reflector modes. We always operate at the mode (1-3/4) for which klystron output is greatest. The reflector voltage when operating at peak output within that mode is approximately 225 V (see Appendix B.1). Figure 23 reveals that reflector voltage is a convenient mode indicator. The optimum voltage within a given mode can be found with the mode sweep. Our mode sweep does not change the reflector voltage sufficiently to display all three modes simultaneously, but it is more than ample to display them individually. If desired, one can observe all three modes by increasing the mean reflector voltage from zero to 225 V while sweeping.

As mentioned previously, Fig. 22 is an idealized sweep. In practice, the mode sweep forms a pattern similar to that shown in Fig. 24(a). Note that the waveforms generated by the forward and return sweeps differ from each other considerably. These waveforms are different because the klystron, which sweeps into and out of oscillation, finds it easier to sustain oscillation than to initiate it.³⁹

2. Using the Mode Sweep

- a. Connect the system as shown in Fig. 25. Set the operating controls (see Figs. 26 and 27 and Table III) as follows:

KLYSTRON POWER SUPPLY

- (1) HV switch at OFF, LINE switch at ON
- (2) BEAM VOLTAGE at 325-V
- (3) GRID VOLTAGE at zero
- (4) REFLECTOR VOLTAGE at 225-V
- (5) AMPLITUDE VOLTS at maximum clockwise
- (6) SELECTOR switches at REFLECTOR and EXT

AUTOMATIC FREQUENCY CONTROL UNIT

- (1) KLYSTRON CAVITY at 5300
- (2) MODE/RESPONSE at SWEEP
- (3) MOD AMP at maximum clockwise
- (4) OSCILLOSCOPE PHASE at 55

- b. Change HV switch, klystron power supply, to ON (high voltage does not come on until the LINE switch has been on for 60 sec).
- c. Monitor the detected signal (Point A, Fig. 25) with an oscilloscope. The pattern resulting should resemble that shown in Fig. 24(a). If not, adjust the OSCILLOSCOPE PHASE control (AFC unit) until it does.

B. Automatic Frequency Control

1. Cavity Resonator Theory

Since the cavity must be excited at a particular mode, and since many modes are possible, it is important that the operator understand the fundamentals of cavity resonance. Basically, a cavity resonator does much the same thing as a conventional tuned circuit, but does it quite differently.

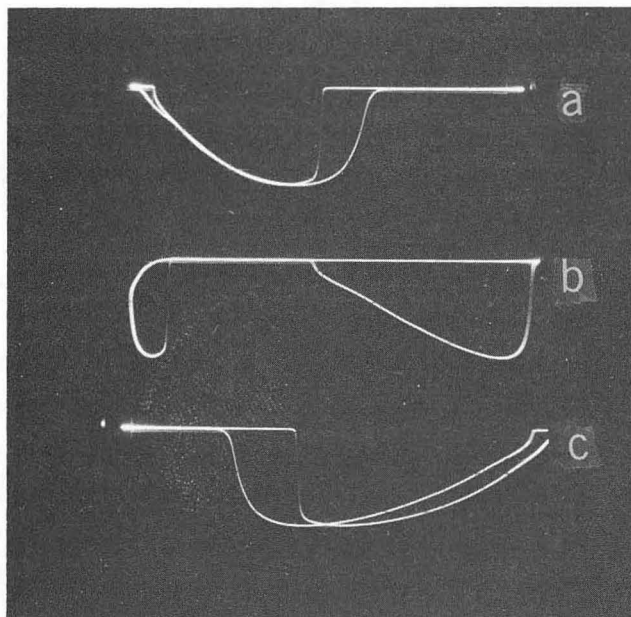

XBB 6712-6816

Fig. 24. Oscilloscope traces showing the mode sweep waveforms that are found in practice. All three traces represent the same conditions except for the OSCILLOSCOPE PHASE control setting, which is (a) 57, (b) 35, and (c) zero. The waveforms generated by the forward and return sweeps are different from each other [see (a)] because the klystron, which sweeps into and out of oscillation, find it easier to sustain oscillation than to initiate it. Vertical sensitivity is 0.2 V/cm. KLYSTRON CAVITY set at 5300.

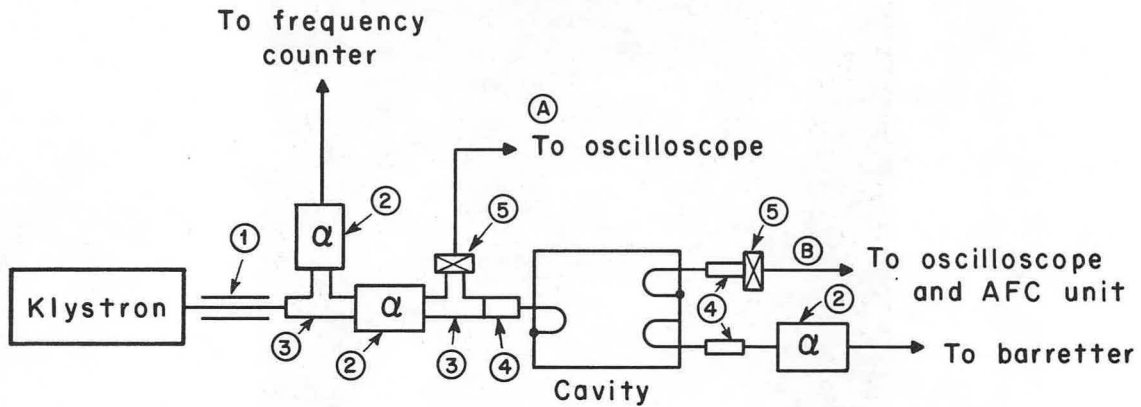

XBL67II-5323

Fig. 25. Simplified diagram of radio frequency system showing the interconnection of components. Numbered components are: (1) Patch cord, *GR type 874-R20LA, 3', (2) attenuator, *GR type 874-G10L, fixed 10 db, (3) Tee, *GR type 874-TL, (4) Panel connector (modified), *GR type 874-P8, (5) crystal detector, Hewlett Packard type 420A. *GR indicates General Radio,

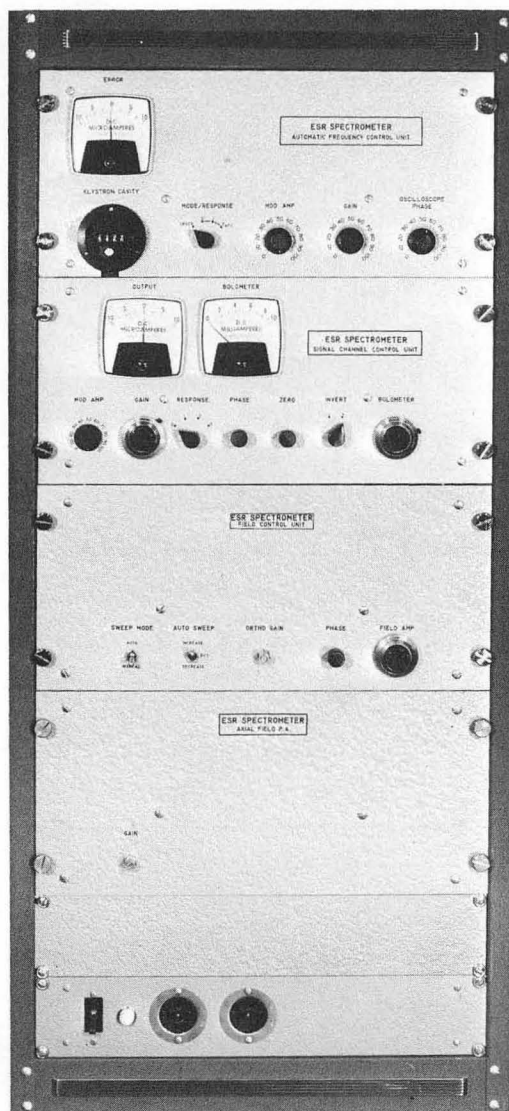

XBB 670-5773

Fig. 26. Control console. It includes (from top to bottom): automatic frequency control unit, signal channel control unit, field control unit, and axial field P. A.

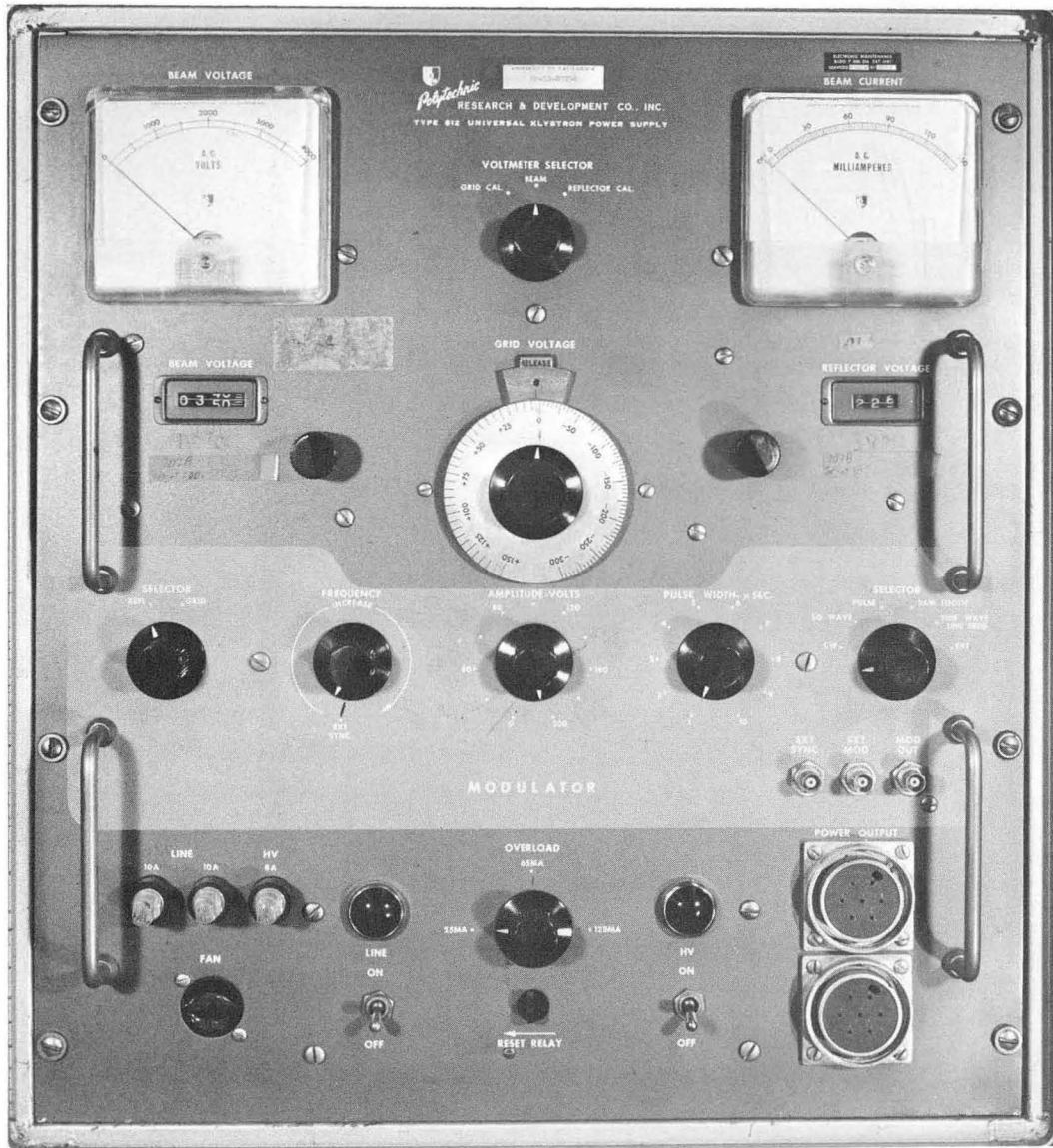

XBB 670-5772

Fig. 27. Klystron power supply.

Conventional tuned circuits rely on the resonance resulting from the mutual exchange of energy between lumped parameters, namely capacitors and inductors. Circulating currents result that favor one frequency and discriminate against others. Cavity resonators, on the other hand, rely on the resonant properties of electrostatic and electromagnetic fields when confined by a suitable enclosure.

Inasmuch as cavity resonators rely on the resonant properties of confined fields, and since the fields in a given enclosure can take many different distributions, it follows that a given cavity can resonate at many different frequencies. The frequency at which it actually does resonate depends upon its dimensions and the field configuration (mode) resulting when it is excited.

Concerning terminology, each mode can be described symbolically. Our cavity is excited at the TE 0,1,2, mode, the prefix TE (transverse electric) denoting that the electrostatic (E) field is always transverse to the cavity axis. The three subscripts, as applied to a cylindrical resonator excited at a TE mode, indicate the number of E field variations along each of the three parameters shown in Fig. 28 (θ , radius, and length).⁴⁰

The first subscript (0) refers to the number of full-cycle variations with respect to θ . If the subscript is zero, the field is circular for TE modes.⁴¹

The second subscript (1) indicates the number of half-cycle variations with respect to radius, but it does not provide a reference radius to which these variations can be referred. This reference can be deduced from knowledge that the cavity walls short out any parallel gradient in their immediate vicinity, and that the field is circular. In view of this, we can conclude that the field vanishes at the walls. The cylinder wall serves as a reference radius, revealing that the field vanishes at the axis, and that it is maximum in the region of half-radius.

The third subscript (2) represents the number of half-cycle variations along the axis. Since the field is zero at both end plates, and since it varies one full cycle along the length of the cavity, we can conclude that it vanishes at a region halfway between the end plates. We can also conclude that the field is maximum in a region $L/4$ distant from each end plate.

Summarizing, the E field is circular, as shown in Fig. 29(a). Radially, it is maximum in the region of half radius, and it vanishes at the axis and at the walls. Longitudinally, it is maximum at two planes, each $L/4$ distant from the center; it vanishes at the center and at both end plates.

Concerning the electromagnetic field pattern, it is defined by equations⁴² that indicate the patterns shown in Fig. 29(b).⁴³ Note that the H field is tangential to all walls.

As mentioned earlier, a given cavity can resonate at many different frequencies, depending upon the mode excited. In most cases, each mode resonates at a different frequency, but not always. For example, the TM 1,1,2 and TE 0,1,2 modes resonate at the same frequency.⁴² We couple to the cavity in a manner that favors the TE 0,1,2 mode.

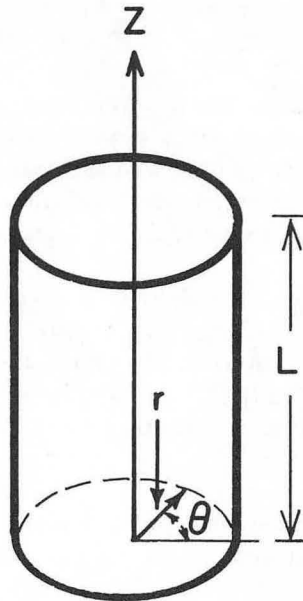

XBL675-2987

Fig. 28. Parameters used for describing the field configuration of a right circular cylinder.

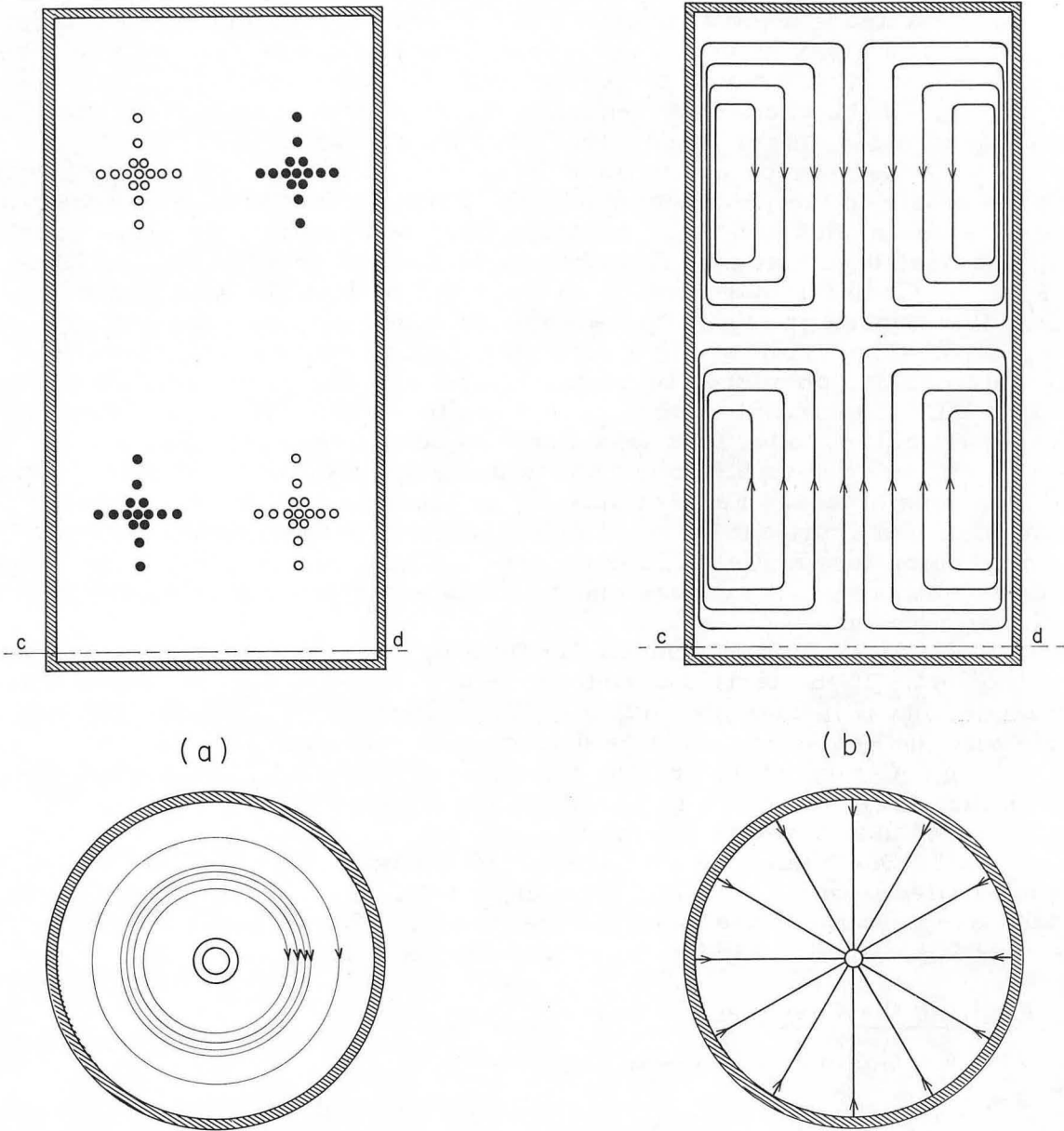

XBL 675-2988

Fig. 29. Cavity resonator field configurations for the TE 0,1,2, mode. (a) E field, (b) H field.

From a practical viewpoint, it is not difficult to excite a particular mode if the following points are kept in mind:

a. The resonant frequency is determined by cavity dimensions and by the mode excited. If the dimensions are known, one can compute the resonant frequency at a given mode. Conversely, if operation is desired at a given frequency and mode, cavity dimensions can be calculated.

b. If the excitation frequency matches that of the cavity resonator at the desired mode, other modes are less likely to be excited.

c. Each mode has definite field configurations. If energy is coupled into the cavity in the proper manner, the coupling mechanism can discriminate against some modes and favor others. Our spectrometer employs coupling loops, oriented so that the H field passes through their planes as illustrated in Fig. 7. Coupling magnitude is determined by loop position relative to that where flux density is high; it is also determined by loop area and orientation.

d. The fields within a resonator induce currents in its walls.⁹ These currents can be considered to be associated with the magnetic flux adjacent to the wall. If the cavity offers opposition to the flow of current associated with a particular mode, it is less likely to be excited at that mode.

e. It is possible to introduce mode suppressors that favor some modes and suppress others. For example, if an electric conductor is strategically located, it can short out the E field associated with an undesired mode without disturbing the E field of the desired mode. Our coupling loops double as mode suppressors; i. e., they short out the electric field of modes with a radial component.

f. One can probe the cavity field in order to find out the mode at which it is excited. If an electric conductor is positioned to suppress some particular mode, but if it does not suppress the resonance in question, one can conclude that the resonance must be due to some other mode.

g. Cavity Q is greater for some modes than for others. Resonator Q for the TE 0,1,2 mode is generally higher than for the other modes, and so the resonance curve is sharper.

h. One cannot be sure that a given cavity is excited at the proper mode from knowledge of its resonant frequency only. This is because different modes can have the same resonant frequency. The resonant frequency for the TM 1,1,2 mode is identical to that for the TE 0,1,2 mode.

2. Exciting the Cavity at the Correct Mode

a. Compute cavity length from⁴⁴

$$L = 11.8/(f^2 - 1.45)^{1/2}, \quad (1)$$

where L is the inside length of the cavity in inches and f is the frequency in gigacycles. Set the adjustable end plate accordingly.

b. Obtain a mode sweep, as described in Section VII.A.2.

c. Change SELECTOR (klystron PS) to CW, monitor klystron frequency with the counter, adjust KLYSTRON CAVITY dial for the frequency desired, and return SELECTOR to EXT.

d. Vary KLYSTRON CAVITY 200 divisions (more if necessary), each side of the dial-setting resulting in 2.c, searching for a dip due to cavity resonance, as shown in Fig. 30. If a dip cannot be found, increase input coupling to the cavity. If several dips are found (see Fig. 30), record the corresponding KLYSTRON CAVITY dial settings for future reference.

e. Monitor the cavity output (Point B of Fig. 25) with an oscilloscope, then tune the KLYSTRON CAVITY control through the same

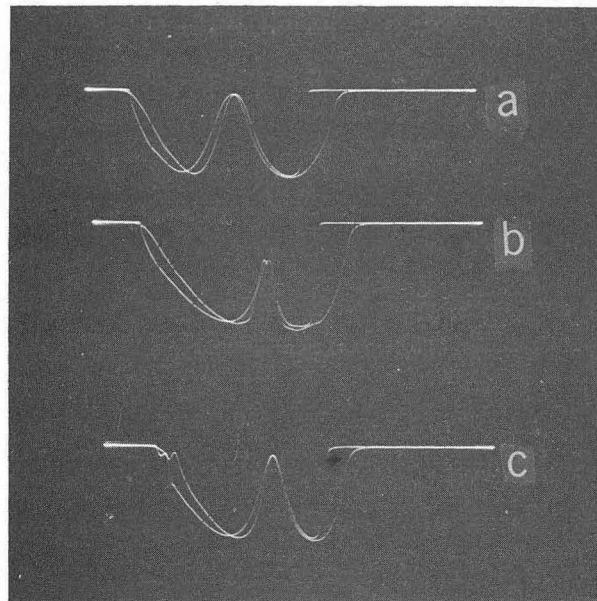

XBB 6712-6817

Fig. 30. Oscilloscope traces showing three cavity resonances, each due to a different mode. Cavity dimensions were fixed; each resonance was obtained by adjusting the KLYSTRON CAVITY control for a dip at the cavity input. KLYSTRON CAVITY settings were: (a) 5405, (b) 5460, the desired resonance, and (c) 5499.

range again (2.d above), searching for resonances (see Fig. 31). Some (at least one) should occur at settings approximating those obtained in 2.d above; others will not be coupled through the cavity. If no resonances can be found, increase output coupling at the cavity.

- f. Assuming that several resonances are found, measure the frequency of each as follows. Set the klystron power supply for CW operation, adjust the KLYSTRON CAVITY control for maximum transmission through the cavity (maximum dc output from the detector monitoring cavity output), then measure the klystron frequency resulting.
- g. Return SELECTOR to EXT, then adjust the KLYSTRON CAVITY control for peak amplitude of the resonance whose frequency most nearly conforms to that computed from Eq. 1. The TE 0,1,2 resonance is generally sharper (higher Q).
- h. If uncertain as to the mode excited, probe the cavity as described in Appendix A.3. The probing procedure can be omitted in most cases.
- i. Check the frequency as described in (f), adjusting the cavity if necessary.
- j. Adjust both coupling loops for maximum output.

3. Locking the Klystron to the Cavity

NOTE: The detailed procedure presented in this section is preceded by a general description of the procedure.

General Procedure

Obtain a mode sweep, adjust KLYSTRON CAVITY for maximum transmission as the klystron sweeps through the desired resonance. Reduce frequency deviation (MOD AMP and AMPLITUDE VOLTS), and adjust REFLECTOR VOLTAGE so that the klystron sweep is centered about the resonance. Change MODE/RESPONSE to AFC; this locks the klystron to the resonance. Set frequency deviation to the smallest value required for lock. Advance GAIN to the highest stable setting. The capacity to minimize frequency changes is dependent upon the gain, higher settings generally giving better regulation. If the setting is too high, the AFC becomes unstable. Warm up the equipment until the frequency drift settles down to an acceptable value.

- a. Excite the cavity at the correct frequency and mode, as described in Section VII.B.2.
- b. Adjust OSCILLOSCOPE PHASE so that the forward and return sweeps coincide, as shown in Fig. 31(b).
- c. Adjust REFLECTOR VOLTAGE* so that the resonance peak is centered about zero horizontal voltage on the oscilloscope, adjusting OSCILLOSCOPE PHASE as necessary.
- d. Change AMPLITUDE VOLTS* to 40, readjust REFLECTOR VOLTAGE* and OSCILLOSCOPE PHASE to keep the resonance peak centered on the oscilloscope.

*The asterisk indicates that a control is at the klystron power supply; all others are located at the AFC Control Unit.

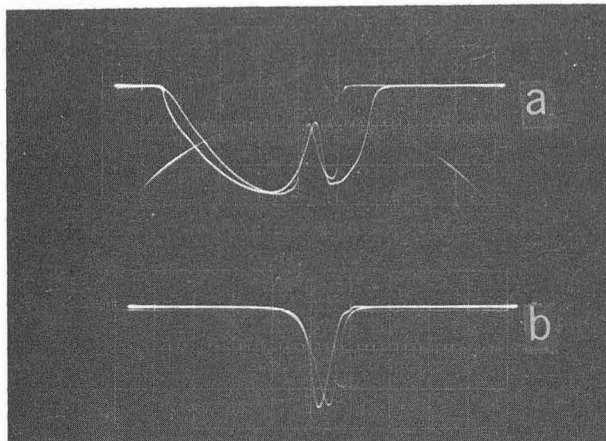

XBB 6712-6818

Fig. 31. Mode sweep showing the desired resonance as it appears at: (a) cavity input (point A of Fig. 25), vertical sensitivity 0.2-V/cm, and (b) cavity output (point B of Fig. 25), vertical sensitivity 0.05-V/cm.

- e. Set MOD AMP at 20, GAIN at 10. Monitor the blue test point at the AFC lock-in amplifier (see Fig. 14) with an oscilloscope probe, and adjust REFLECTOR VOLTAGE* for minimum signal (null amplitude increases both sides of resonance).
- f. Change MODE/RESPONSE to 2.
- g. Increase REFLECTOR VOLTAGE* until ERROR meter indicates zero current.
- h. Decrease MOD AMP setting until ERROR meter kicks off zero. Advance MOD AMP control slightly so that meter reads zero again.
- i. Advance GAIN until the blue test point is just short of saturation (approximately 4 V, p-p).
- j. Test to see that the system sustains lock when REFLECTOR VOLTAGE* is varied over a 20-V range. Adjust for zero current on the ERROR meter. This is the desired operating point.

C. Obtaining a Spectrum

Since a spectrum has not been obtained yet, detailed instructions are not delineated. Tables III through V outline the functions of the various controls, but the best procedure will have to be determined experimentally. Salient points of interest are:

- a. One sets the cavity to the appropriate frequency, then locks the klystron to it.
- b. The Helmholtz coils must be excited in quadrature. The axial and ortho gains must be adjusted for equal contributions from each pair of coils. Cavity attenuation is probably different for each pair, and so it may become necessary to empirically determine the relative current required by each set of coils.
- c. The accuracy with which the cavity frequency must be set is related to the dynamic range that can be swept by the magnetic field. The cavity will be subject to temperature considerations which could require temperature control or an increased field.

VIII. MAINTENANCE ADJUSTMENTS

A. Automatic Frequency Control Unit

1. Lock-in Amplifier, 12 kHz

- a. Test the amplifier as described in Section III.D of Ref. 30.
- b. Adjust the PHASE control as follows:
 - (i) Set GAIN at maximum clockwise.
 - (ii) Monitor the blue test point (Fig. 14) with an oscilloscope probe, apply an attenuated signal from REF OUT to SIG IN, and adjust the attenuator so that the monitored signal is 2 V peak-to-peak (see Ref. 30, p. 49, for attenuator).
 - (iii) Adjust PHASE for maximum negative ERROR current on meter.

*The asterisk indicates that a control is at the klystron power supply; all others are located at the AFC Control Unit.

D. Tables of Operating Controls

Table III. Automatic frequency control unit, control function chart

<u>Control</u>	<u>Function</u>
Klystron cavity	Determines frequency range that can be swept by klystron.
Mode/Response	Selects type of operation, klystron mode display (SWEEP), or automatic frequency control. Also determines AFC time constant.
Mod Amp	Controls klystron frequency deviation.
Gain	Controls frequency stabilization, higher settings giving better regulation. If control is advanced too far, the regulating circuit sometimes becomes unstable.
Oscilloscope phase	Controls phase of sinusoid applied to the horizontal deflection plates of the oscilloscope.

Table IV. Signal channel control unit, control function chart

<u>Control</u>	<u>Function</u>
Mod Amp	Controls amplitude of the sinusoidal voltage applied to the field control unit. Determines sweep range.
Gain	Controls signal level applied to lock-in amplifier.
Response	Determines time constant of lock-in amplifier.
Phase	Controls phase of gating signal to synchronous detector.
Zero	Balances output from lock-in amplifier when signal is absent.
Invert	Reverses polarity of current through OUTPUT meter, also the recorder.
Bolometer	Controls bias current to the bolometer. Set to 8.75 mA on BOLOMETER meter.

Table V. Field control unit, control function chart.

<u>Control</u>	<u>Function</u>
Sweep mode	Selects source of field control, motor (AUTO) or manual.
Auto sweep	Determines direction of motor controlling field current.
Ortho gain	Controls amplitude of current to orthogonal coils.
Phase	Controls phase of current in axial coils relative to that in orthogonal coils. Set for 90 deg.
Field amp	Controls field current amplitude when SWEEP MODE is at MANUAL, indicates relative amplitude when SWEEP MODE is at AUTO.

2. Frequency-Modulation Amplifier

- a. Monitor the waveform at MOD OUT with an oscilloscope.
- b. Set MOD AMP at maximum clockwise.
- c. Adjust MOD (Fig. 11) for 200-V, peak-to-peak.

3. Sweep Amplifier

- a. Monitor the waveform at EXT SWEEP with an oscilloscope.
- b. Adjust SW AMP (Fig. 11) for 120 V peak-to-peak.

4. Preamplifier Module, A₀

- a. Set G₁ (Fig. 11) at maximum counterclockwise.

B. Signal Channel Control Unit

Test the 560-Hz lock-in amplifier as described in Section III.D of Ref. 30.

IX. PERFORMANCE

Total performance cannot yet be evaluated, but electronic performance can be expressed in a limited way. The AFC, for example, stabilizes the klystron's frequency to that of the cavity to approximately 1 ppm. The cavity frequency changes with temperature, however, and that appears to be the limiting consideration. Performance can best be deduced through use of the appendices, which treat the various components in detail.

X. FUTURE CONSIDERATIONS

Since this is a preliminary design, it is obviously subject to change. Sensitivity requirements are severe, and it may become necessary to improve the signal-to-noise ratio. If so, one would probably optimize the various subsystems, perhaps add a compensating bolometer.⁶ Superheterodyne and other techniques¹⁶ might prove superior, but our initial approach is

directed towards a simple instrument. Computer techniques can average out noise,⁴⁵ but a high-sensitivity spectrometer offers more promise.

As indicated earlier, the cavity is temperature-sensitive, and so it is somewhat difficult to set its frequency with precision. Also, the cavity walls attenuate the magnetic field appreciably, which reduces the dynamic range over which the field can be swept with the audio power available. These considerations indicate that the desired resonance will be somewhat difficult to find unless the cavity environment is temperature-controlled. Such a problem could be ameliorated by reducing the frequency at which the magnetic field is modulated, but that would impair the noise figure.

Concerning automatic frequency control, the klystron is frequency-modulated, generating sidebands that can cause line broadening and spurious responses, as discussed earlier. If the sample line width cannot be reduced to 5 kHz or less, it may become necessary to increase the frequency at which the AFC is modulated. As an alternative approach, one might experiment with various modulation indices, searching for one that reduces low-order side-band components to a negligible value.

ACKNOWLEDGMENTS

This spectrometer was developed under the direction of Professor Harold S. Johnston, Inorganic Materials Research Division. Many of the ideas presented here were conveyed to me by Mr. Phillip Dow, who, in collaboration with Professor Johnston, conceived the instrument described. Mr. Kenneth Ransdell assisted with the design and construction of the cavity and sweep mechanisms. The power amplifier schematic is reproduced through the courtesy of the Dyna Company, Philadelphia, Pennsylvania. All work was done under auspices of the U. S. Atomic Energy Commission.

APPENDICES

A. Cavity1. Q measurements

Referring to the test setup shown in Fig. 32, we adjusted both coupling loops for maximum power transfer through the cavity. When the loops were so adjusted, power output from the cavity measured 1.4 mW at resonance ($f_0 = 1444$ MHz). The frequency separation between half-power frequencies (bandwidth) measured 800 kHz, indicating a loaded $Q(Q_L)$ of 1800.

We reduced the coupling at both loops considerably, adjusting them so that only $6\ \mu\text{W}$ was coupled through the cavity at resonance. The separation between half-power frequencies measured only 30 kHz, which indicates that the unloaded Q is approximately 48000.

2. Frequency Stability

These tests were not extensive; we simply measured the resonant frequency of the cavity at various time intervals after turning the equipment on. To do this, we adjusted the reflector voltage for maximum transmission through the cavity, then measured the klystron frequency resulting. Figure 33 indicates the frequency change with time. It shows that the cavity frequency decreased approximately 60 kHz during the 60-minute warmup period. When we repeated this test at a later date, the cavity frequency decreased approximately 100 kHz during the 60-minute warmup. Cavity frequency is sensitive to temperature, and so it is influenced by all the variables that contribute to room temperature.

3. Modes

The electric field distribution must correspond to that shown in Fig. 29(a). Note that the E field is circular, that it is maximum in the region of half-radius, and that it vanishes at the axis and at the walls. Longitudinally, it is maximum at two planes, each $L/4$ distant from the center; it vanishes at the center and at both end plates.

Determine that the cavity is excited at the proper mode as follows. Insert a long wire through its axis; this should not appreciably affect the resonance signal (see Fig. 31(b)). Insert a radial probe through a coupling-loop porthole. This, too, should cause little change. Remove the fixed end plate, and insert a probe of the type shown in Fig. 34 through the hole at its center. Replace the end plate, observe the resonance signal, and position the probe along the cavity's length so that it changes the resonance signal appreciably. Maximum perturbation should occur when the probe wire is $L/4$ distant from each end plate. Rotate the probe to determine if the E field is circular.

Concerning the H field, the configuration corresponds to that shown in Fig. 29(b). The coupling loops are oriented so that the plane of each loop is normal to the flux that it intercepts.

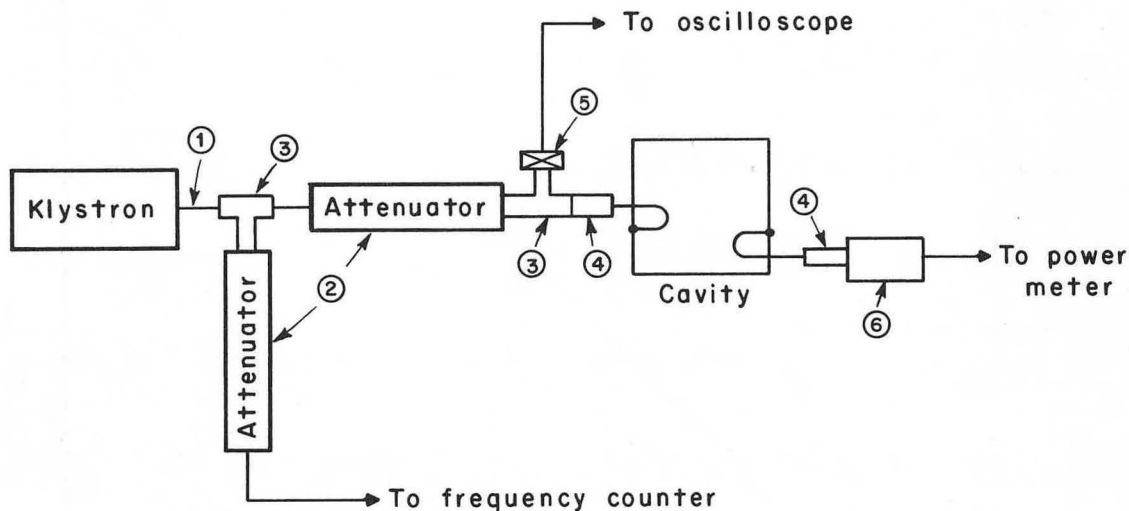

XBL6710-5324

Fig. 32. Test setup for measuring cavity Q . Numbered components are: (1) Patch cord, *GR (General Radio) type 874-R20LA, 3 ft; (2) attenuator, *GR type 874-G10L, fixed, 10 db; (3) Tee, *GR type 874-TL; (4) panel connector (modified), *GR type 874-P8; (5) crystal detector, Hewlett-Packard type 420A; (6) thermistor mount, Hewlett-Packard type 478 A. The power meter is **HP 431C, and the frequency counter is **HP type 5246L with **HP 5254B frequency converter. *GR indicates General Radio, **HP indicates Hewlett Packard.

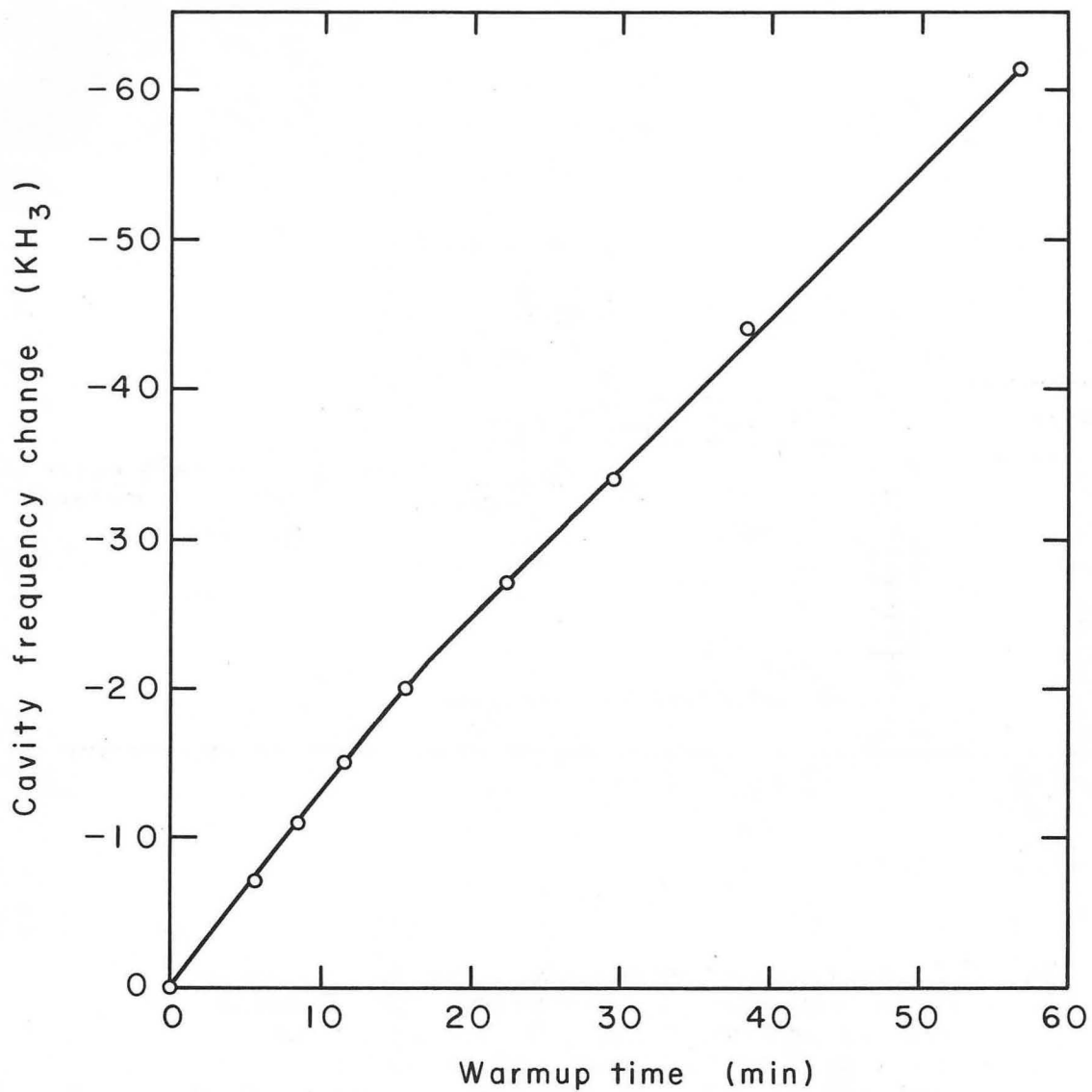

XBL676-3379

Fig. 33. Frequency change of resonant cavity versus warm-up time.

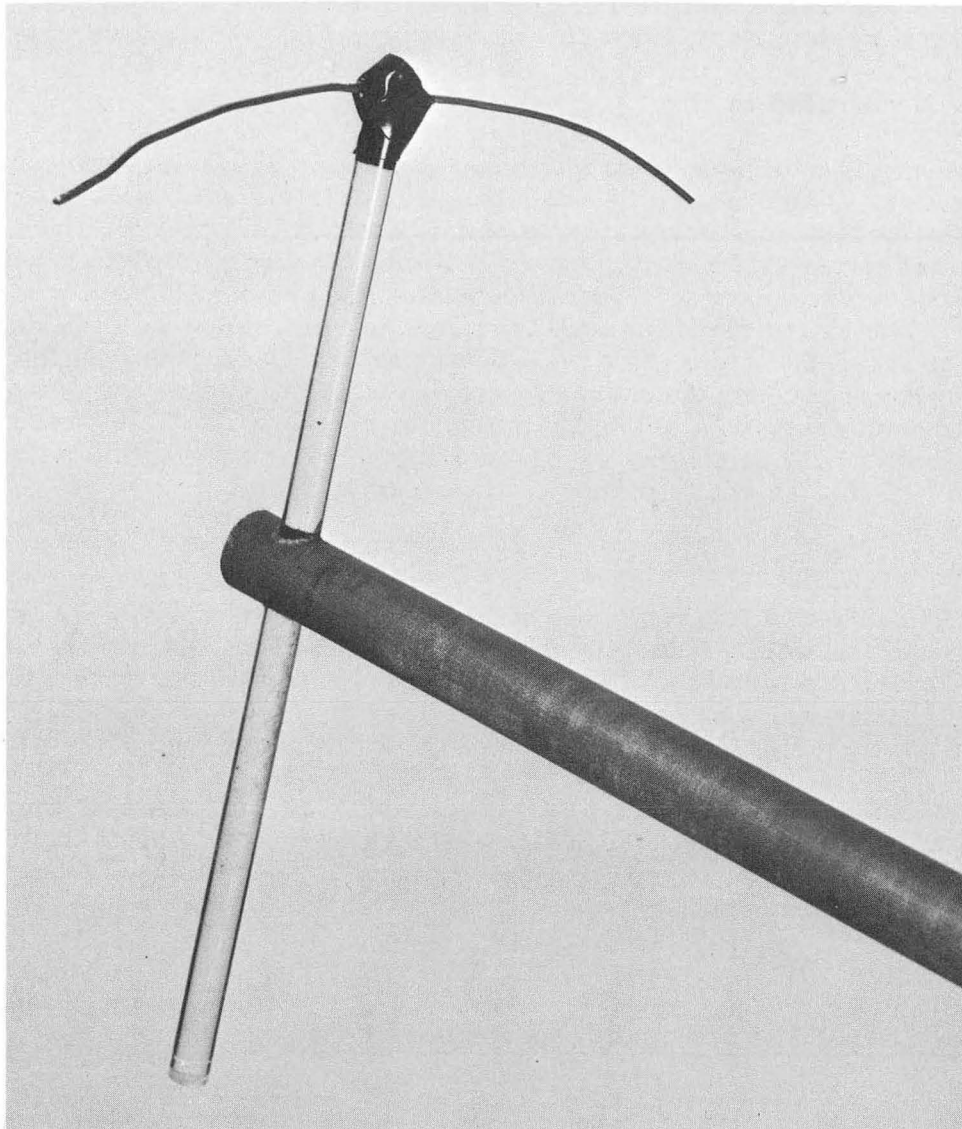

XBB 670-5967

Fig. 34. Probe for testing cavity E field. Maximum perturbation should occur when the wire is $L/4$ distant from each end plate, where L is the inside length of the cavity.

4. Coupling Loops

Energy may be fed into or taken from a cavity resonator with a probe, a loop, or a slit.⁴⁶ We chose to couple with loops because they are very effective in discriminating against some modes while favoring others. In particular, we wish to excite the TE 0,1,2 mode and to reject the TM 1,1,2 mode, which resonates at the same frequency. To do this, we orient each coupling loop so that it intercepts the H field associated with the TE 0,1,2 mode, as illustrated in Fig. 7.

Coupling loops are impedance-matching devices, much the same as transformers. When used in a transmission scheme such as ours, they transform the load and generator impedances in a way that reduces transmission losses through the cavity. The input coupling loop effects an impedance match between the generator impedance and the shunt resistance of the cavity.⁴⁷ The latter is influenced by the load resistance and the degree of coupling to it; i. e., coupling at the output loop. Each coupling loop effects an impedance transformation that is equal to the square of the ratio of the coupled to uncoupled flux. The transformation ratio can be altered by changing loop area, position, or orientation. Our coupling loops were formed from 7 in. of No. 16 wire (mandrel diameter 1.25 in.).

5. Magnetic Field Attenuation

The 280-Hz field induces eddy currents in the cavity walls that attenuate the magnetic field within the cavity. This attenuation increases with frequency, cavity diameter, and wall thickness; it decreases with resistivity.¹⁰ Our cavity is brass, and so it attenuates less than one of copper. Silver plating improves the Q, but it has negligible influence upon the attenuation.

Measurements with a search coil (680 000 cm² area) indicated an attenuation of 7 at 250 Hz; it increased to 15 at 550 Hz, to 22 at 780 Hz. These values were measured with only one axial coil, and with one end plate removed from the cavity.

B. Klystron

1. Power Output and Frequency vs Reflector Voltage

With the test setup shown in Fig. 35, we recorded klystron output as a function of reflector voltage (see Table VI). The resulting plot, Fig. 23, reveals that the klystron oscillates only if the reflector voltage lies within certain limits, and that power output is greatest in the vicinity of 225 V. Figure 23 also reveals that the klystron can oscillate in any one of three different modes. Our spectrometer is operated at the reflector mode for which klystron output is greatest, which corresponds to the 1-3/4 mode.

We also measured the frequencies at which power output was 50% of the maximum value obtained for each reflector mode. These frequencies, tabulated in Table VII, reveal that the frequency range covered by each reflector mode is approximately the same. The range of frequencies covered is dependent upon the setting of the KLYSTRON CAVITY control.

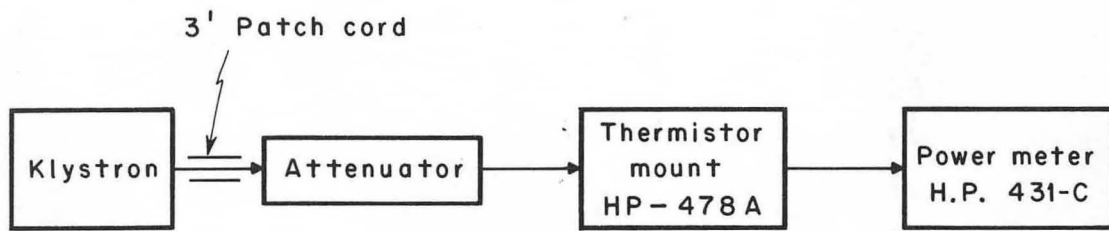

XBL6710-5326

Fig. 35. Test setup for measuring klystron output as a function of reflector voltage. The klystron was operated CW for the measurements.

Table VI. Klystron power output vs reflector voltage. ^a

Reflector volts	Power output (mW)
24	1.18
27	2.35
35	1.18
59	0
63	23.5
65.5	33
78	47
87.5	33
90	23.5
95	0
165	0
186	141
195	197
224.5	282
244	197
248	141
253	0

a. Klystron cavity dial setting at 5380, beam voltage at 325 V, and grid voltage at zero.

Table VII. Klystron half-power frequencies vs mode.

Mode	Half-power frequencies ^a (MHz)
1-3/4	1410.7 and 1419.1
2-3/4	1410.9 and 1422.2
3-3/4	1413.6 and 1419.2

a. Frequencies at which power output is 50% of the maximum value obtained at the mode listed.

We made additional measurements at the intended operating point in order to determine klystron modulation sensitivity; i. e., frequency sensitivity to reflector voltage. These measurements indicate that sensitivity to be approximately 110 kHz/V. This measurement is useful in calculating the AFC loop gain.

2. Loading Effects

In Fig. 25, note the 10-db attenuator included between klystron output and cavity input. This attenuator isolates the klystron from cavity susceptance, and it serves to prevent frequency discontinuities. The minimum attenuation required is related to the "pulling figure" of the oscillator and to the loaded Q of the cavity.²³ The maximum attenuation permissible is determined by klystron output capability and by the power level that must be delivered to the cavity for satisfactory recovery of the spectrum sought.

3. Frequency versus Klystron Cavity Dial-Setting

With the test setup shown in Fig. 36, we set the klystron power supply for CW operation and 225 V at the reflector. We then recorded klystron frequency for various KLYSTRON CAVITY dial settings. The resulting values are tabulated in Table VIII. These frequencies change with loading and other factors, but Table VIII is useful for indicating the approximate frequency change to be expected for a given change in the KLYSTRON CAVITY dial-setting. Table VIII indicates that the klystron frequency changes approximately 260 kHz for each dial division when the klystron is operated near 1440 MHz.

4. Frequency Drift versus Warmup Time

We locked the klystron to the cavity, then measured the klystron's frequency at various time intervals after turning the AFC on. The graph, Fig. 37, indicates that the klystron required approximately 1 hour to stabilize. The frequency drift levels off to a value determined by the frequency stability of the cavity (see Fig. 33).

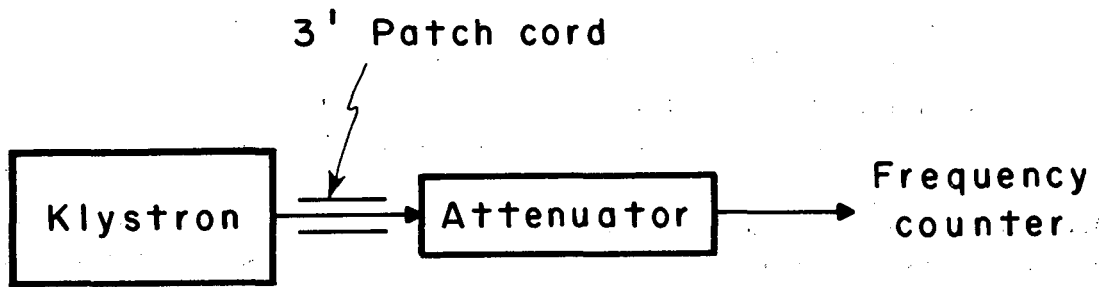

XBL6710-5325

Fig. 36. Test setup for measuring klystron frequency as a function of KLYSTRON CAVITY dial setting.

Table VIII. Klystron frequency vs klystron cavity dial setting.

Dial setting	Klystron frequency ^a (MHz)
5400	1424.662
5410	1427.169
5420	1430.497
5430	1433.115
5440	1435.788
5450	1438.423
5460	1441.023
5470	1443.633
5480	1446.381
5490	1448.961
5500	1450.216

a. Reflector voltage at 225 V, beam voltage at 325 V, and grid voltage at 0.

We then added the operational amplifier shown in Fig. 11. This reduced the warmup time to about 10 min, at which time cavity stability becomes the principal source of drift.

C. Automatic Frequency Control

1. Loop Gain Measurements

We locked the klystron to the cavity as described in Section VII.B.3, changed the reflector power supply output 10 volts, and determined that the klystron frequency changed about 200 Hz. If we compare this frequency change with the open-loop value (measured 110 kHz/V), we find that the AFC reduced the influence of reflector voltage changes at the power supply by a factor of 5500. This correction factor, termed loop gain, is a useful figure in defining AFC performance. Loop gain is controlled by such factors as GAIN setting and cavity Q. It is a measure of the AFC's ability to regulate out unwanted frequency changes, higher values generally resulting in better regulation.

The AFC must sometimes regulate frequency changes that occur quite rapidly. In order to do so effectively, its speed of response must be faster than the change to be regulated. If this response is extended appreciably more than is necessary, noise perturbations can depreciate regulator performance. The effects of those perturbations can sometimes be reduced if the frequency response is lowered. For this reason, we include a selector switch (MODE/RESPONSE) that permits us to control the time constant.

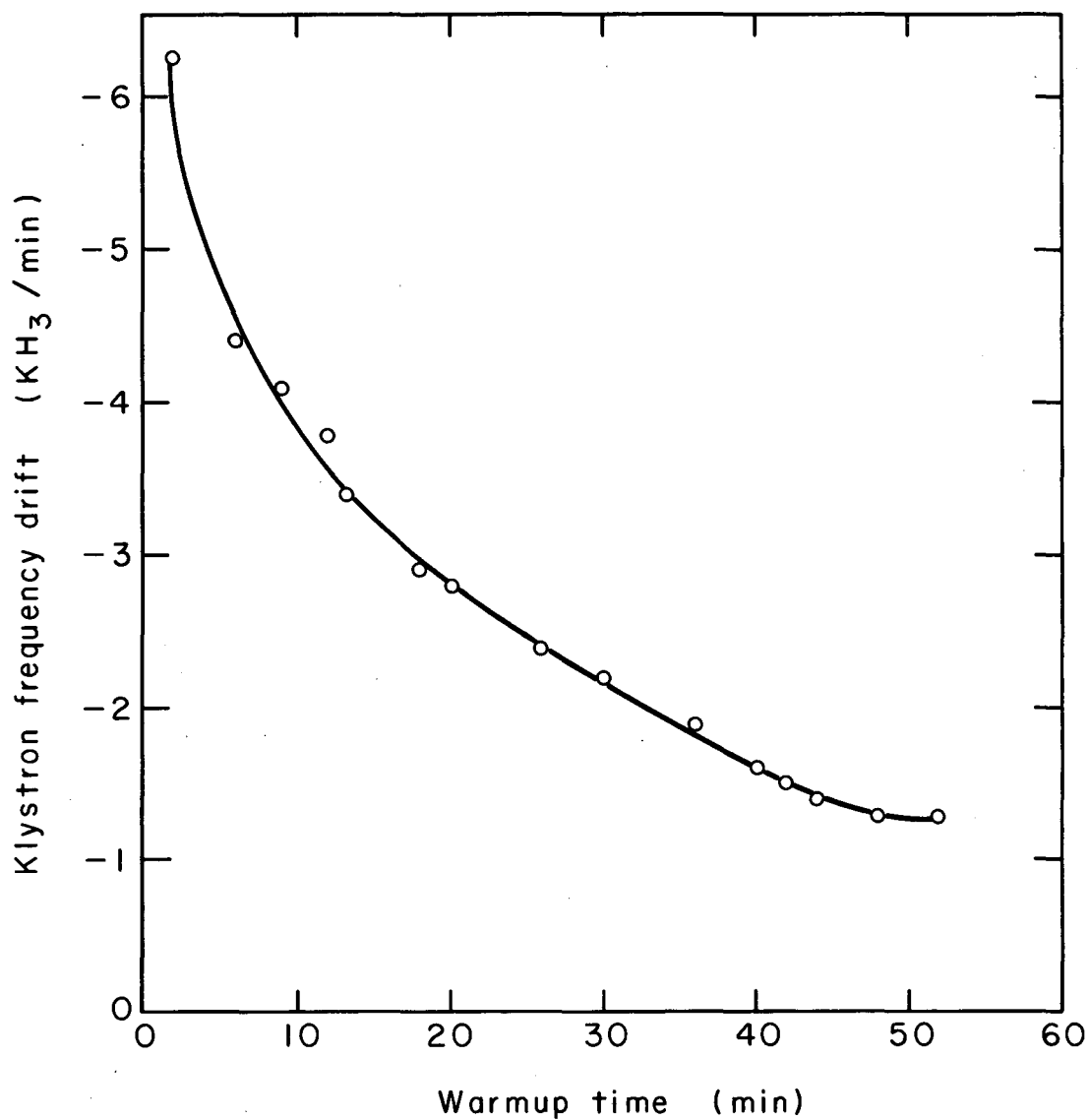

XBL676-3378

Fig. 37. Klystron frequency drift vs warmup time, AFC on, and previous to adding operational amplifier.

The operational amplifier (see Fig. 11) extends the dynamic range over which lock is possible. Clarifying its output is ± 10 V, five times that of the phase detector. Amplifier output sustains lock when the reflector power supply changes more than 20 V.

D. Helmholtz Coils

1. General

We designed the Helmholtz coils so that they can be driven by commercial audio-frequency power amplifiers. To do this, we made their ac resistance compatible with the impedance taps available at the amplifier output. This ac resistance is a function of frequency, higher frequencies increasing its value. We found that aluminum frames increase the resistance, and so we use epoxy coils instead. This construction permits us to drive more current through them when using an amplifier of a given power capability. We tune out the coil reactance with a series capacitor of the appropriate value.

The 280-Hz modulation induces eddy currents in the cavity that attenuate the axial field by a factor of 8.¹⁰ This is in agreement with our measurements taken with a search coil (680 000 cm²).

2. Field Strength Measurements

We excited one coil (46 cm radius) with the axial field power amplifier and a 10- μ F series capacitor. The resonant frequency measured 200 Hz. We adjusted the current for 1 A peak-to-peak through the coil, then measured the magnetic field strength with a search coil positioned at its center. We measured 16.5 V, p-p, across the search coil. Sensitivity of the latter is 12 V/G at 280 Hz. Correcting for frequency, we find that the magnetic field strength is 1.92 G/A.

We repeated this measurement with one of the smaller coils, 40 cm radius. The resonant frequency measured 245 Hz, the search coil output was 20 V p-p. Solving for magnetic field strength, we find that it is 1.91 G/A. These measurements indicate that a 1-A current produces essentially the same field strength in either coil, large or small.

3. Inductance, Resistance, and Q Measurements

a. 40 cm radius:

1. Measured with General Radio Impedance Bridge, Type No. 1650-A, and an external generator (HP-200AB).

Frequency (Hz)	L _{meas} (mH)	Q _{meas}	Q _{theoret}
1000	43	57	129
500	43	46	65
250	43	30	32

2. The dc resistance measured 2.1 ohms on the GR impedance bridge.

b. 46 cm radius:

1. Measured with General Radio Impedance Bridge, Type No. 1650-A, and an external generator (HP-200AB).

Frequency (Hz)	L_{meas} (mH)	Q_{meas}	Q_{theoret}
1000	65	60	152
500	65	48	76
250	65	31	38

2. The dc resistance measured 2.7 ohms on the GR impedance bridge.

3. MUTUAL INDUCTANCE MEASUREMENTS

- a. $L_1 = 64$ mH, $L_2 = 60$ mH,
- b. Series aiding, $L_t = 136$ mH,
- c. Series opposing, $L_t = 113$ mH,
- d. Conclusion: $M = 6$ mH.

FOOTNOTES AND REFERENCES

1. The NMR-EPR Staff of Varian Associates, NMR and EPR Spectroscopy (Pergamon Press, Inc., New York, 1960).
2. L. M. Jackman, Applications of Nuclear Magnetic Resonance Spectroscopy in Organic Chemistry (Pergamon Press, Inc., New York, 1959), p. 32.
3. J. P. Wittke and R. H. Dicke, Redetermination of the Hyperfine Splitting in the Ground State of Atomic Hydrogen, Phys. Rev. 103, 620 (1956).
4. Kenneth D. Granzow, Homogeneity of the Magnetic Field of a Helmholtz Coil, Sandia Corporation Monograph, SCR-193, July 1960.
5. See Ref. 1, p. 50.
6. S. E. Bresler, E. M. Saminskii, and E. N. Kazbekov, A Paramagnetic Resonance Microwave Spectrometer for the Study of Chemical Reactions, Zh. Tekh. Fiz. 27, 2535 (1957).
7. C. G. Montgomery, Technique of Microwave Measurements, Radiation Laboratory Series (Boston Technical Publishers, Inc., Lexington, Massachusetts, 1964), Vol. 11, p. 297.
8. F. E. Terman, Radio Engineer's Handbook, First Edition (McGraw-Hill Book Co., Inc., New York, 1943), p. 265.
9. J. P. Kinzer and I. G. Wilson, End Plate and Side Wall Currents in Circular Cylinder Cavity Resonator, Bell System Tech. J. 26, 31 (1947).
10. William R. Smythe, Static and Dynamic Electricity (McGraw-Hill Book Co., Inc., New York, 1950), p. 411.
11. G. Feher, Sensitivity Considerations in Microwave Paramagnetic Resonance Absorption Techniques, Bell System Tech. J. 36, 449 (1957), see p. 452.
12. R. D. Moore and O. C. Chaykowsky, Modern Signal Processing Technique for Optimal Signal to Noise Ratios, Princeton Applied Research, Technical Bulletin 109, 1963.
13. See Ref. 11, p. 459.
14. P. H. Miller, Jr., Noise Spectrum of Crystal Rectifiers, Proc. I. R. E. 35, 252 (1947).
15. See Ref. 11, p. 475.
16. E. A. Faulkner and P. W. Whippey, Electron-Spin-Resonance Spectrometer Using High-Frequency Amplitude Modulation, Proc. I. E. E. 113 [7], 1159 (1966).

17. R. Beringer and J. G. Castle, Jr., Magnetic Resonance Absorption in Nitric Oxide, *Phys. Rev.* 78, 581 (1950).
18. The lock-in technique minimizes noise generated by devices that precede it, provided that these noises are not modulated by the reference.
19. See Ref. 11, p. 465.
20. Ucarsil R-101 metal protectant, manufactured by Silicones Div., Union Carbide, New York, N. Y. Since the TE 0,1,2 mode does not require good contact between the cylinder and the end plates, one can apply the silicone to the entire surface of these parts.
21. Patch cord, 3 ft, General Radio Type 874-R20 LA.
22. General Radio Type 874-G10L, Fixed, 10 db.
23. R. V. Pound, Frequency Stabilization of Microwave Oscillators, *Proc. I. R. E.* 35, 1405 (1947).
24. See Ref. 11, p. 451.
25. F. E. Terman, Radio Engineering, Third Edition (McGraw-Hill Book Company, Inc., New York, 1947), p. 484.
26. *Ibid*, p. 487.
27. R. D. Moore, Lock-In Amplifiers for Signals Buried in Noise, *Electronics* 35 [23], 40 (1962).
28. H. S. Black, Modulation Theory, (D. Van Nostrand Company, Inc., New York, 1953), p. 39.
29. J. P. Wittke, A Redetermination of the Hyperfine Splitting in the Ground State of Atomic Hydrogen (University Microfilms, Ann Arbor, Michigan, Doctoral Dissertation Series, Publication No. 13,741), p. III - 24.
30. Kenneth W. Lamers, "Do-It-Yourself" Lock-in Amplifiers, Radio and Audio Frequency, Lawrence Radiation Laboratory Report UCRL-16632, Jan. 1966.
31. Amerac Inc., Model 198, Beverly, Mass.
32. Universal Klystron Power Supply, Polytechnic Research and Development Co., Type 812, Brooklyn, New York.
33. Filmohm Type CWV-875-100, New York, N. Y. (two used).
34. Coaxial bolometer-thermistor mount, Narda Model 560B, Plainview, L. I., N. Y.

35. Princeton Applied Research Corp. , Model CR-4A, with Model AM-1 input transformer.
36. Helipot, Single Turn, 50 k Ω , Model 5613.
37. Dynakit Mark III, Dyna Co. , 3916 Powelton Ave. , Philadelphia, Pa.
38. See Ref. 25, p. 449.
39. See Ref. 7, p. 30.
40. See Ref. 7, p. 297.
41. See Ref. 25, p. 131.
42. See Ref. 7, p. 299.
43. S. Ramo and J. Whinnery, Fields and Waves in Modern Radio (John Wiley and Sons, Inc. , New York), 2nd edition, Table 9.05.
44. See Ref. 7, p. 297 (the design parameters have been substituted in the equation).
45. M. Klein and B. Barton, Enhancement of Signal-to-Noise Ratio by Continuous Averaging: Application to Magnetic Resonance, Rev. Sci. Instr. 34[7], 754 (1963).
46. Department of the Army Technical Manual, TM 11-673, Generation and Transmission of Microwave Energy, Department of the Army, June 1953, p. 90.
47. See Ref. 25, p. 147.

This report was prepared as an account of Government sponsored work. Neither the United States, nor the Commission, nor any person acting on behalf of the Commission:

- A. Makes any warranty or representation, expressed or implied, with respect to the accuracy, completeness, or usefulness of the information contained in this report, or that the use of any information, apparatus, method, or process disclosed in this report may not infringe privately owned rights; or
- B. Assumes any liabilities with respect to the use of, or for damages resulting from the use of any information, apparatus, method, or process disclosed in this report.

As used in the above, "person acting on behalf of the Commission" includes any employee or contractor of the Commission, or employee of such contractor, to the extent that such employee or contractor of the Commission, or employee of such contractor prepares, disseminates, or provides access to, any information pursuant to his employment or contract with the Commission, or his employment with such contractor.

