

# UC San Diego

## UC San Diego Electronic Theses and Dissertations

### Title

Index Coding: Fundamental Limits, Coding Schemes, and Structural Properties

### Permalink

<https://escholarship.org/uc/item/5jj8f93m>

### Author

Arbabjolfaei, Fatemeh

### Publication Date

2017

Peer reviewed|Thesis/dissertation

UNIVERSITY OF CALIFORNIA, SAN DIEGO

**Index Coding  
Fundamental Limits, Coding Schemes, and Structural Properties**

A dissertation submitted in partial satisfaction of the  
requirements for the degree  
Doctor of Philosophy

in

Electrical Engineering  
(Communication Theory and Systems)

by

Fatemeh Arbabjolfaei

Committee in charge:

Professor Young-Han Kim, Chair  
Professor Daniel Mertz Kane  
Professor Jeffrey Remmel  
Professor Paul H. Siegel  
Professor Kenneth A. Zeger

2017

Copyright  
Fateme Arbabjolfaei, 2017  
All rights reserved.

The dissertation of Fatemeh Arbabjolfaei is approved,  
and it is acceptable in quality and form for publication  
on microfilm and electronically:

---

---

---

---

---

---

Chair

University of California, San Diego

2017

## DEDICATION

*To my lovely parents, Pari and Ali, and my beloved spouse, Mahmood,  
for their unconditional support  
and my sweetheart, Saba, who added endless love and joy to my life.*

## EPIGRAPH

*You are not a drop in the ocean, you are the entire ocean in a drop.*

–Jalaluddin Rumi

## TABLE OF CONTENTS

Signature Page	. . . . .	iii
Dedication	. . . . .	iv
Epigraph	. . . . .	v
Table of Contents	. . . . .	vi
List of Figures	. . . . .	viii
List of Tables	. . . . .	x
Acknowledgements	. . . . .	xi
Vita	. . . . .	xvi
Abstract of the Dissertation	. . . . .	xviii
Chapter 1	Introduction . . . . .	1
	1.1 Motivation and the Problem Definition . . . . .	1
	1.2 Historical Remarks . . . . .	7
	1.A Capacity Region Under Average Error Probability Criterion	8
	1.B Proof of Lemma 1.1 . . . . .	10
Chapter 2	Mathematical Preliminaries . . . . .	11
	2.A Proof of Lemma 2.4 . . . . .	20
Chapter 3	Multiletter Characterization of the Capacity . . . . .	21
	3.A Proof of Lemma 3.1 . . . . .	29
	3.B Proof of Lemma 3.2 . . . . .	29
	3.C Proof of Proposition 3.4 . . . . .	30
	3.D Proof of Theorem 3.2 . . . . .	31
	3.E Proof of Proposition 3.5 . . . . .	32
Chapter 4	Structural Properties of Index Coding Capacity . . . . .	34
	4.A Proof of Lemma 4.1 . . . . .	44
	4.B Proof of Theorem 4.1 . . . . .	46
Chapter 5	Performance Limits . . . . .	49
	5.1 Maximum Acyclic Induced Subgraph (MAIS) Bound . . . . .	49
	5.2 Polymatroidal Bound . . . . .	51
	5.3 Information Inequalities and Lower Bounds . . . . .	58
	5.A Proof of Proposition 5.2 . . . . .	64

	5.B Proof of Lemma 5.1 . . . . .	65
	5.C Proof of Proposition 5.4 . . . . .	66
	5.D Proof of Proposition 5.7 . . . . .	67
Chapter 6	Coding Schemes . . . . .	74
	6.1 MDS Code . . . . .	74
	6.2 Clique Covering . . . . .	76
	6.3 Fractional Clique Covering . . . . .	77
	6.4 Fractional Local Clique Covering . . . . .	79
	6.5 Fractional Local Partial Clique Covering . . . . .	80
	6.6 General Linear Codes . . . . .	82
	6.7 Flat Coding . . . . .	85
	6.8 Composite Coding . . . . .	88
	6.9 Recursive Codes . . . . .	98
	6.A Proof of Proposition 6.8 . . . . .	102
	6.B Proof of Proposition 6.9 . . . . .	103
	6.C Proof of Proposition 6.10 . . . . .	106
Chapter 7	Criticality . . . . .	107
	7.1 A Sufficient Condition . . . . .	108
	7.2 Necessary Conditions . . . . .	111
	7.3 Application . . . . .	115
	7.A Proof of Proposition 7.4 . . . . .	118
	7.B Proof of Lemma 7.1 . . . . .	119
	7.C Proof of Lemma 7.2 . . . . .	120
Chapter 8	Index Coding Capacity For Small Problems . . . . .	121
Chapter 9	Approximate Capacity for Some Classes . . . . .	124
	9.1 Ramsey Numbers . . . . .	124
	9.2 Approximate Capacity for Some Index Coding Classes . .	128
	9.A Proof of Theorem 9.1 . . . . .	132
Chapter 10	Index Coding Versus Distributed Storage and Guessing Games	133
	10.1 Locally Recoverable Distributed Storage Problem . . . . .	134
	10.2 Guessing game on Directed Graphs . . . . .	137
	10.3 Equivalence Between Distributed Storage and Guessing Games . . . . .	141
	10.4 Complementarity Between Index Coding and Distributed Storage . . . . .	142
	10.A Proof of Proposition 10.3 . . . . .	145
Bibliography	. . . . .	150



## LIST OF FIGURES

Figure 1.1:	An index coding example with three receivers. . . . .	2
Figure 1.2:	The index coding problem. . . . .	3
Figure 1.3:	The graph representation for the index coding problem with $A_1 = \{2, 3\}$ , $A_2 = \{1\}$ , and $A_3 = \{1, 2\}$ . . . . .	6
Figure 2.1:	(a) A 6-node graph that is the lexicographic product $G_0 \circ G_1$ of two smaller graphs $G_0$ and $G_1$ . (b) The 3-node graph $G_0$ . (c) The 2-node graph $G_1$ . . . . .	17
Figure 3.1:	The graph representation for the index coding problem with $A_1 = \{2, 3\}$ , $A_2 = \{1\}$ , and $A_3 = \{1, 2\}$ . . . . .	22
Figure 3.2:	Confusion graphs for the directed graph $G$ shown in Figure 3.1 corresponding to the integer tuple $\mathbf{t} = (t_1, t_2, t_3) = (1, 1, 1)$ . (a) $\Gamma_{\mathbf{t}}^{(11)}(G)$ . (b) $\Gamma_{\mathbf{t}}^{(21)}(G)$ . (c) $\Gamma_{\mathbf{t}}^{(31)}(G)$ . (d) $\Gamma_{\mathbf{t}}(G)$ . . . . .	23
Figure 4.1:	Graph examples with (a) no interaction, (b) one-way interac- tion, (c) complete one-way interaction, and (d) complete two- way interaction among its two parts. . . . .	35
Figure 4.2:	(a) A 6-node graph that is the generalized lexicographic product $G_0 \circ (G_1, G_2, G_3)$ (b) The 3-node graph $G_0$ (c) The 2-node graph $G_1$ (d) The 2-node graph $G_2$ (e) The 2-node graph $G_3$ . . . . .	35
Figure 4.3:	(a) A two-node graph with no edge, (b) a two-node graph with one edge, (c) a two-node graph with two edges. . . . .	37
Figure 4.4:	A 4-node acyclic graph. . . . .	39
Figure 4.5:	Construction of an index code for index coding problem $G_0 \circ$ $(G_1, \dots, G_m)$ by concatenating the index codes for problems $G_1, \dots, G_m$ as the inner codes and the index code for problem $G_0$ as the outer code. . . . .	43
Figure 4.6:	(a) A 6-node graph that is the lexicographic product $G_0 \circ G_1$ of two smaller graphs $G_0$ and $G_1$ . (b) The 3-node graph $G_0$ . (c) The 2-node graph $G_1$ . . . . .	44
Figure 5.1:	An index coding instance with three messages. . . . .	51
Figure 5.2:	A 5-node index coding problem . . . . .	57
Figure 6.1:	A 3-message index coding problem with $\beta = 2$ , which is achiev- able by a $(5, 3)$ MDS code. . . . .	75
Figure 6.2:	A three message side information graph with $\beta = 2$ that is achievable by the clique covering scheme. . . . .	76
Figure 6.3:	A five-message side information graph with $\beta = 2.5$ that is achievable by the fractional clique covering scheme. . . . .	78

Figure 6.4:	A six-message side information graph for which $\beta_{\text{FL}} = 2 < \beta_{\text{comp}} = 3$ . . . . .	79
Figure 6.5:	An index coding problem with $\beta_{\text{FLP}} = 7/2 < \beta_{\text{FL}} = 4$ . . . . .	81
Figure 6.6:	A 3-message index coding instance for which the flat coding is optimal. . . . .	85
Figure 6.7:	A 4-node index coding instance for which the flat coding scheme is not optimal. . . . .	89
Figure 6.8:	Composite coding scheme . . . . .	92
Figure 6.9:	The “dual” index coding problem. . . . .	94
Figure 6.10:	An index coding problem with $\beta'_R = 3 < \beta_{\text{FLP}} = 7/2$ . Here the bounds are computed by solving the respective linear programs. . . . .	100
Figure 6.11:	An index coding problem with $\beta = 3 < \beta(\mathcal{R}_{\text{LTS}}) = \beta_{\text{LTS}} = 7/2$ . Here $\beta$ is achieved by composite coding. . . . .	101
Figure 6.12:	A summary of the coding schemes. . . . .	101
Figure 7.1:	(a) $G _{\{1,2,3\}}$ is a unicycle, but $G$ is not a unicycle. (b) $G _{\{1,2,3\}}$ and $G _{\{1,3,4\}}$ are both unicyles. . . . .	108
Figure 7.2:	A critical 5-message index coding problem. Although the edge $2 \rightarrow 5$ does not belong to any unicycle, it is critical. The capacity region is achieved by composite coding with or without the edge $2 \rightarrow 5$ . . . . .	110
Figure 7.3:	A 5-message noncritical index coding problem that satisfies all the three necessary conditions in Theorem 7.2. The capacity region is the same with or without the edge $4 \rightarrow 1$ and is achieved by the composite coding scheme. . . . .	114
Figure 7.4:	A noncritical 6-message index coding problem with nondegraded side information sets. The edges $5 \rightarrow 3$ , $3 \rightarrow 1$ , and $6 \rightarrow 5$ lie on a directed cycle, but do not belong to any unicycle. . . . .	117
Figure 9.1:	(a) A 4-node planar graph (the edge $\{1, 3\}$ can be drawn such that it does not cross $\{2, 4\}$ ). (b) A 5-node nonplanar graph. . . . .	126
Figure 9.2:	(a) A 4-node graph with 5 edges. (b) The corresponding 5-node line graph. . . . .	126
Figure 9.3:	(a) The complement of $C_6$ . (b) The fuzzy circular interval model of $\overline{C_6}$ where the intervals are shown by dotted arcs and $\phi(1) = \phi(2) = a$ , $\phi(3) = \phi(4) = b$ , $\phi(5) = d$ , and $\phi(6) = c$ . . . . .	127
Figure 10.1:	The relationship between index coding, distributed storage, optimal guessing number, and optimal complementary guessing number. . . . .	145

## LIST OF TABLES

Table 8.1: The number of 6-message index coding instances that satisfy properties $P_1$ - $P_4$ . . . . .	122
Table 9.1: Ramsey numbers for planar graphs . . . . .	126
Table 9.2: Ramsey numbers for line graphs . . . . .	127
Table 9.3: Ramsey numbers for fuzzy circular interval graphs . . . . .	128

## ACKNOWLEDGEMENTS

I would like to express my sincere and profound gratitude to my advisor, Professor Young-Han Kim, for his continuous and generous support in the course of my Ph.D. studies. This dissertation would not have been possible without his invaluable insight in network information theory and persistent guidance. I am highly indebted to him for giving me the opportunity to work with him, providing a friendly research environment, and teaching me how to think about a problem, how to face difficulties, and how to write and present my work. He teaches from his heart, whether it is a basic writing rule or a deep information theoretic concept. Young-Han has had an impact that goes far beyond my academic life; I hope I can emulate his patience and optimism in the relationship with others. I am specifically full of gratitude for his support and understanding during the last year of my Ph.D. when in addition to my research, I was involved in taking care of my baby.

Besides Professor Young-Han Kim, I would like to thank Professor Mohammed Salah Baouendi, Professor Ken Kreutz-Delgado, Professor Tara Javidi, Professor Alon Orlitsky, Professor Jason Schweinsberg, and Professor Paul Siegel for being wonderful teachers. Also worthy of thanks are Professor Tara Javidi and Professor Ramesh Rao for their generous support at the beginning of my Ph.D.

I would also like to sincerely thank Professor Daniel Kane, Professor Jeffrey Remmel, Professor Paul H. Siegel, Professor Jacques Verstraete, and Professor Kenneth A. Zeger, for kindly accepting to be a committee member of my exams.

I was so lucky to be surrounded by so many smart and nice colleagues who made grad life at UCSD fun and memorable. I am thankful to Saharnaz Baghdadchi, Bernd Bandemer, Alankrita Bhatt, Chiao-Yi Chen, Najmeh Ebrahimi, Shouvik Ganguly, Nadim Ghaddar, Fatemeh Hosseini, Somayeh Imani, Mercedeh Khajavikhan, Sudeep Kamath, Anusha Lalitha, Jing Li, Mahta Mousavi, Moham-

mad Naghshvar, Bakhtiyar Neyman, Hosung Park, Sankeerth Rao, Jongha Ryu, Eren Sasoglu, Shiva Shahin, Pinar Sen, Lele Wang, Yu Xiang, and Menglin Zeng as well as former visitors of Professor Kims group Professor Xianglan Jin and Professor Sang-Hyo Kim. I had a lot of fun sharing puzzles and mathematical problems at Professor Kims group meetings. My special thanks go to Lele, who is always there for any kind of help. I would also like to thank Bernd in particular for helping me with my research. I like his systematic way of thinking and appreciate his ability in conveying his knowledge to others.

Most importantly, I would like to thank my family for their unconditional love and support which warmed my heart, especially during the time that I was living far from home. I am so thankful to my beloved spouse, Mahmood, for encouraging me to pursue my interests and listening to my complaints and frustrations. This journey was filled with enormous joy and love with you. The last but not the least, I am thankful for having my cute baby Saba, who made our lives more joyful and fun and cooperated in writing this dissertation!

Chapter 1, in full, is a reprint of the material in the paper: Fatemeh Arbabjolfaei and Young-Han Kim, “Elements of index coding”, to be submitted to *Foundations and Trends in Communications and Information Theory*. The dissertation author was the primary investigator and author of this paper.

Chapter 2, in part, is a reprint of the material in the paper: Fatemeh Arbabjolfaei and Young-Han Kim, “Elements of index coding”, to be submitted to *Foundations and Trends in Communications and Information Theory*. The dissertation author was the primary investigator and author of this paper.

Chapter 3, in part, is a reprint of the material in the papers: Fatemeh Arbabjolfaei and Young-Han Kim, “Structural properties of index coding capacity using fractional graph theory”, *Proceedings of the IEEE International Symposium*

on *Information Theory*, Hong Kong, June 2015; and Fatemeh Arbabjolfaei and Young-Han Kim, “Generalized lexicographic products and the index coding capacity”, submitted to *IEEE Transactions on Information Theory*; and Fatemeh Arbabjolfaei and Young-Han Kim, “Elements of index coding”, to be submitted to *Foundations and Trends in Communications and Information Theory*. The dissertation author was the primary investigator and author of this paper.

Chapter 4, in full, is a reprint of the material in the papers: Fatemeh Arbabjolfaei and Young-Han Kim, “Structural properties of index coding capacity using fractional graph theory”, *Proceedings of the IEEE International Symposium on Information Theory*, Hong Kong, June 2015; and Fatemeh Arbabjolfaei and Young-Han Kim, “Generalized lexicographic products and the index coding capacity”, submitted to *IEEE Transactions on Information Theory*; and Fatemeh Arbabjolfaei and Young-Han Kim, “Elements of index coding”, to be submitted to *Foundations and Trends in Communications and Information Theory*. The dissertation author was the primary investigator and author of this paper.

Chapter 5, in full, is a reprint of the material in the papers: Fatemeh Arbabjolfaei, Bernd Bandemer, Young-Han Kim, Eren Sasoglu, Lele Wang, “On the capacity region for index coding”, *Proceedings of the IEEE International Symposium on Information Theory*, Istanbul, Turkey, July 2013; and Fatemeh Arbabjolfaei and Young-Han Kim, “Elements of index coding”, to be submitted to *Foundations and Trends in Communications and Information Theory*. The dissertation author was the primary investigator and author of this paper.

Chapter 6, in part, is a reprint of the material in the papers: Fatemeh Arbabjolfaei, Bernd Bandemer, Young-Han Kim, Eren Sasoglu, Lele Wang, “On the capacity region for index coding”, *Proceedings of the IEEE International Symposium on Information Theory*, Istanbul, Turkey, July 2013; and Fatemeh Arbab-

jolfaei, Bernd Bandemer, Young-Han Kim, “Index coding via random coding”, *Proceedings of the Iran Workshop on Communication and Information Theory*, Tehran, Iran, May 2014; and Fatemeh Arbabjolfaei and Young-Han Kim, “Local time sharing for index coding”, *Proceedings of the IEEE International Symposium on Information Theory*, Honolulu, HI, USA, July 2014; and Fatemeh Arbabjolfaei and Young-Han Kim, “Elements of index coding”, to be submitted to *Foundations and Trends in Communications and Information Theory*. The dissertation author was the primary investigator and author of this paper.

Chapter 7, in full, is a reprint of the material in the papers: Fatemeh Arbabjolfaei and Young-Han Kim, “On critical index coding problems”, *Proceedings of the IEEE Information Theory Workshop*, Jeju Island, Korea, Oct. 2015; and Fatemeh Arbabjolfaei and Young-Han Kim, “Elements of index coding”, to be submitted to *Foundations and Trends in Communications and Information Theory*. The dissertation author was the primary investigator and author of this paper.

Chapter 8, in full, is a reprint of the material in the paper: Fatemeh Arbabjolfaei and Young-Han Kim, “Elements of index coding”, to be submitted to *Foundations and Trends in Communications and Information Theory*. The dissertation author was the primary investigator and author of this paper.

Chapter 9, in full, is a reprint of the material in the papers: Fatemeh Arbabjolfaei and Young-Han Kim, “Approximate capacity of index coding for some classes of graphs”, *Proceedings of the IEEE International Symposium on Information Theory*, Barcelona, Spain, July 2016; and Fatemeh Arbabjolfaei and Young-Han Kim, “Elements of index coding”, to be submitted to *Foundations and Trends in Communications and Information Theory*. The dissertation author was the primary investigator and author of this paper.

Chapter 10, in full, is a reprint of the material in the papers: Fatemeh

Arbabjolfaei and Young-Han Kim, “Three stories on a two-sided coin: index coding, locally recoverable distributed storage, and guessing games on graphs”, *Proceedings of the 53rd Annual Allerton Conference on Communication, Control, and Computing*, Monticello, Illinois, Oct. 2015; and Fatemeh Arbabjolfaei and Young-Han Kim, “Elements of index coding”, to be submitted to *Foundations and Trends in Communications and Information Theory*. The dissertation author was the primary investigator and author of this paper.



## VITA

- 2007 B. S. in Electrical Engineering (Communication), Isfahan University of Technology, Isfahan, Iran
- 2010 M. S. in Electrical Engineering (Communication), Isfahan University of Technology, Isfahan, Iran
- 2017 Ph. D. in Electrical Engineering (Communication Theory and Systems), University of California, San Diego

## PUBLICATIONS

Fatemeh Arbabjolfaei and Young-Han Kim, “Generalized lexicographic products and the index coding capacity”, submitted to *IEEE Transactions on Information Theory*, 2016.

Fatemeh Arbabjolfaei and Young-Han Kim, “Elements of index coding”, to be submitted to *Foundations and Trends in Communications and Information Theory*.

Yucheng Liu, Parastoo Sadeghi, Fatemeh Arbabjolfaei, Young-Han Kim “On the capacity for distributed index coding”, to be submitted to *IEEE Transactions on Information Theory*.

Fatemeh Arbabjolfaei and Young-Han Kim, “Approximate capacity of index coding for some classes of graphs”, *IEEE International Symposium on Information Theory (ISIT 2016)*, Barcelona, Spain, July 2016.

Fatemeh Arbabjolfaei and Young-Han Kim, “Three stories on a two-sided coin: index coding, locally recoverable distributed storage, and guessing games on graphs”, *53rd Annual Allerton Conference on Communication, Control, and Computing*, Monticello, Illinois, Oct. 2015.

Fatemeh Arbabjolfaei and Young-Han Kim, “Structural properties of index coding capacity using fractional graph theory”, *IEEE International Symposium on Information Theory (ISIT 2015)*, Hong Kong, June 2015.

Fatemeh Arbabjolfaei and Young-Han Kim, “On critical index coding problems”, *IEEE Information Theory Workshop (ITW 2015)*, Jeju Island, Korea, Oct. 2015.

Fatemeh Arbabjolfaei and Young-Han Kim, “Local time sharing for index coding”, *IEEE International Symposium on Information Theory (ISIT 2014)*, Honolulu, HI, USA, July 2014.

Fatemeh Arbabjolfaei, Bernd Bandemer, Young-Han Kim, “Index coding via random coding”, *Iran Workshop on Communication and Information Theory (IWCIT 2014)*, Tehran, Iran, May 2014.

Fatemeh Arbabjolfaei, Bernd Bandemer, Young-Han Kim, Eren Sasoglu, Lele Wang, “On the capacity region for index coding”, *IEEE International Symposium on Information Theory (ISIT 2013)*, Istanbul, Turkey, July 2013.

Parastoo Sadeghi, Fatemeh Arbabjolfaei, Young-Han Kim “Distributed index coding”, *IEEE Information Theory Workshop (ITW 2016)*, Cambridge, UK, September 2016.

Yucheng Liu, Parastoo Sadeghi, Fatemeh Arbabjolfaei, Young-Han Kim “On the capacity for distributed index coding”, *IEEE International Symposium on Information Theory (ISIT 2017)*, Aachen, Germany, June 2017 B.C.

ABSTRACT OF THE DISSERTATION

**Index Coding  
Fundamental Limits, Coding Schemes, and Structural Properties**

by

Fatemeh Arbabjolfaei

Doctor of Philosophy in Electrical Engineering  
(Communication Theory and Systems)

University of California, San Diego, 2017

Professor Young-Han Kim, Chair

Originally introduced to minimize the number of transmissions in satellite communication, index coding is a canonical problem in network information theory that studies the fundamental limit and optimal coding schemes for broadcasting multiple messages to receivers with different side information. The index coding problem provides a simple yet rich model for several important engineering problems in network communication, such as content broadcasting, peer-to-peer communication, distributed caching, device-to-device relaying, and interference

management. It also has close relationships to network coding, distributed storage, and guessing games.

This dissertation aims to provide a broad overview of this fascinating problem, focusing on the simplest form of unicast index coding. A unified view on coding schemes based on algebraic, graph-theoretic, and information-theoretic approaches is presented. Although the optimal communication rate, namely, the capacity is open in general, several bounds and structural properties are established. The relationships between index coding, distributed storage, and guessing game on directed graphs are also discussed.

# Chapter 1

## Introduction

### 1.1 Motivation and the Problem Definition

Consider the wireless communication system consisting of one server and three receivers, as depicted in Figure 1.1. The server has three distinct messages  $x_1, x_2$ , and  $x_3$ . Receiver  $i \in \{1, 2, 3\}$  is interested in message  $x_i$  and has some of the other messages as side information. In particular, receiver 1 has message  $x_2$ , receiver 2 has  $x_1$  and  $x_3$ , and receiver 3 has  $x_1$  as side information. We wish to communicate all the messages to designated receivers using the minimum possible number of broadcast transmissions.

One naive strategy is to send one message at a time, which takes overall three transmissions. Alternatively, if the server transmits two coded messages  $x_1 + x_2$  and  $x_3$  (assuming that the messages can be represented in a common finite field), then every receiver can recover its desired message using the received coded messages and its side information. Indeed, receiver 1 can recover  $x_1$  from the received message  $x_1 + x_2$  and its side information  $x_2$ . Similarly, receiver 2 can recover  $x_2$  from  $x_1 + x_2$  and  $x_1$ . Receiver 3 can clearly This simple example

shows that sending coded messages may decrease the number of needed broadcast transmissions.

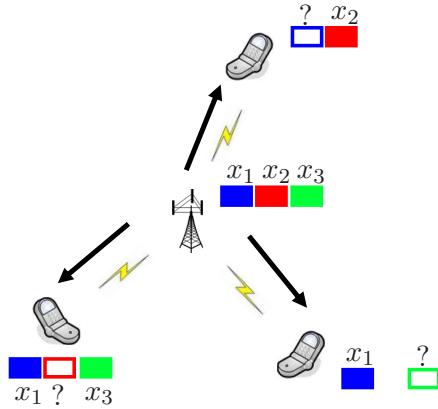
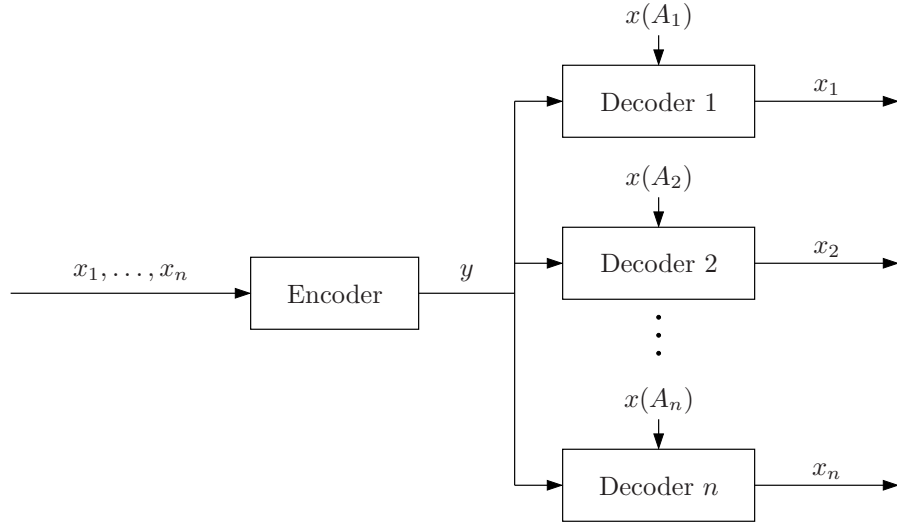

**Figure 1.1:** An index coding example with three receivers.

Generalizing the above example, we study the communication problem depicted in Figure 1.2, which is commonly referred to as the index coding problem. In this canonical problem in network information theory, a server has a tuple of  $n$  messages  $x^n = (x_1, \dots, x_n)$ ,  $x_i = (x_{i1}, \dots, x_{it_i}) \in \mathbb{F}_q^{t_i}$ , for some finite field  $\mathbb{F}_q$ , and is connected to  $n$  receivers via a noiseless broadcast channel. Receiver  $i \in [n] := \{1, 2, \dots, n\}$  is interested in message  $x_i$  and has a set of other messages  $x(A_i) := (x_j, j \in A_i)$ ,  $A_i \subseteq [n] \setminus \{i\}$  as side information. Assuming that the server knows side information sets  $A_1, \dots, A_n$ , one wishes to characterize the minimum amount of information to be broadcast from the server, and to find the optimal coding scheme that achieves this minimum.

More precisely, a  $(t_1, \dots, t_n, r)$  *index code* is defined by

- an encoder  $\phi : \prod_{j=1}^n \mathbb{F}_q^{t_j} \rightarrow \mathbb{F}_q^r$  that maps the message  $n$ -tuple  $x^n$  to an index  $y = (y_1, \dots, y_r) \in \mathbb{F}_q^r$  and
- $n$  decoders, where the decoder at receiver  $i \in [n]$ ,  $\psi_i : \mathbb{F}_q^r \times \prod_{j \in A_i} \mathbb{F}_q^{t_j} \rightarrow \mathbb{F}_q^{t_i}$ , maps the received index  $\phi(x^n)$  and the side information  $x(A_i)$  back to  $x_i$ .



**Figure 1.2:** The index coding problem.

Thus, for every  $x^n \in \prod_{j=1}^n \mathbb{F}_q^{t_j}$ ,

$$\psi_i(\phi(x^n), x(A_i)) = x_i, \quad i \in [n].$$

A  $(t, \dots, t, r)$  code is written as a  $(t, r)$  code. If the encoder of a code is a linear function of  $x_{ij}$ ,  $i \in [n]$ ,  $j \in [t_i]$ , and the decoders are linear functions of  $x_{ij}$ ,  $i \in [n]$ ,  $j \in [t_i]$ , and  $y_j$ ,  $j \in [r]$ , the code is referred to as a *linear index code*. If  $t_i = 1$  for all  $i \in [n]$ , then the linear index code is said to be a *scalar linear index code*. Otherwise, the code is referred to as a *vector linear index code*.

A rate tuple  $(R_1, \dots, R_n)$  is said to be *achievable* for the index coding problem if there exists a  $(t_1, \dots, t_n, r)$  index code such that

$$R_i \leq \frac{t_i}{r}, \quad i \in [n].$$

The *capacity region*  $\mathcal{C}$  of the index coding problem is defined as the closure of the

set of all achievable rate tuples. One can also define the *vanishing error capacity region* which is identical to the capacity region of the index coding problem (see Appendix 1.A for rigorous definition and details).

Note that the definition of the capacity region depends on the finite field  $\mathbb{F}_q$  on which the messages are defined and it may well be denoted by  $\mathcal{C}^{(q)}$  to emphasize this dependence. However, as we will prove in Appendix 1.B, the choice of  $\mathbb{F}_q$  is irrelevant to the actual capacity region itself.

**Lemma 1.1.** *For any two finite fields  $\mathbb{F}_q$  and  $\mathbb{F}_{q'}$ ,*

$$\mathcal{C}^{(q)} = \mathcal{C}^{(q')}.$$

Therefore, for the rest of this manuscript, we assume WLOG that  $\mathbb{F}_2$  is used in a given index code.

One can define *linearly achievable* rate tuple and *linear capacity region*  $\mathcal{C}_L$  similarly. As opposed to the capacity region, the linear capacity region of the index coding problem may depend on the chosen finite field  $\mathbb{F}_q$ .

Let  $\boldsymbol{\lambda} = (\lambda_1, \dots, \lambda_n)$  be a nonnegative real tuple. Define the  $\boldsymbol{\lambda}$ -directed capacity  $C(\boldsymbol{\lambda})$  of the index coding problem as

$$C(\boldsymbol{\lambda}) = \max\{R: R\boldsymbol{\lambda} \in \mathcal{C}\}. \quad (1.1)$$

**Remark 1.1.** The capacity region can be written in terms of  $\boldsymbol{\lambda}$ -directed capacities.

$$\mathcal{C} = \bigcup_{\boldsymbol{\lambda}} \{(R_1, \dots, R_n): R_i \leq C(\boldsymbol{\lambda})\lambda_i, i \in [n]\}. \quad (1.2)$$

Note that if  $\boldsymbol{\lambda} = c\boldsymbol{\lambda}'$  for some constant  $c$ , then  $C(\boldsymbol{\lambda})\boldsymbol{\lambda} = C(\boldsymbol{\lambda}')\boldsymbol{\lambda}'$  and thus in (1.2), it suffices to take the union only over normalized vectors, e.g., over  $\boldsymbol{\lambda}$  such that



$$\sum_{j=1}^n \lambda_j = n.$$

The  $\mathbf{1}$ -directed capacity of the index coding problem is referred to as the *symmetric capacity* (or the *capacity* in short), that is

$$C_{\text{sym}} = C(\mathbf{1}) = \max\{R: (R, \dots, R) \in \mathcal{C}\}.$$

The symmetric capacity can be equivalently defined as

$$C_{\text{sym}} = \sup_r \sup_{(t,r) \text{ codes}} \frac{t}{r} = \lim_{r \rightarrow \infty} \sup_{(t,r) \text{ codes}} \frac{t}{r}, \quad (1.3)$$

where equality follows by Fekete's lemma [1] and the superadditivity

$$\sup_{(t,r_1+r_2) \text{ codes}} t \geq \sup_{(t_1,r_1) \text{ codes}} t_1 + \sup_{(t_2,r_2) \text{ codes}} t_2.$$

The reciprocal of the symmetric capacity,  $\beta = 1/C_{\text{sym}}$ , is referred to as the *broadcast rate*, which can be alternatively defined as

$$\beta = \inf_t \inf_{(t,r) \text{ codes}} \frac{r}{t} = \lim_{t \rightarrow \infty} \inf_{(t,r) \text{ codes}} \frac{r}{t}. \quad (1.4)$$

Any instance of the index coding problem is fully determined by the side information sets  $A_1, \dots, A_n$ , and is represented compactly by a sequence  $(i|A_i), i \in [n]$ . For example, the 3-message index coding problem with  $A_1 = \{2\}$ ,  $A_2 = \{1, 3\}$ , and  $A_3 = \{1\}$  in Figure 1.1 is represented as

$$(1|2), (2|1, 3), (3|1).$$

An instance of the problem can be equivalently specified by a directed graph with  $n$  vertices, commonly referred to as the *side information graph*. Each vertex of

the side information graph  $G = (V, E)$  corresponds to a receiver (and its desired message) and there is a directed edge  $j \rightarrow i$  if and only if (iff) receiver  $i$  knows message  $x_j$  as side information, i.e.,  $j \in A_i$  (see Figure 1.3). Hence, the number of index coding problems with  $n$  messages is equal to the number of nonisomorphic directed graphs with  $n$  vertices [2, Seq. A000273], which blows up quickly with  $n$ . Throughout, we identify an instance of the index coding problem with its side information graph  $G$  and often write “index coding problem  $G$ .” We also denote the broadcast rate and the capacity region of problem  $G$  with  $\beta(G)$  and  $\mathcal{C}(G)$  respectively. Dependence on  $G$  may be omitted if it does not cause any ambiguity. The goal is to characterize the capacity region or the symmetric capacity for the general index coding problem and to determine the coding scheme that can achieve it.

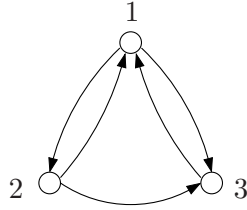

**Figure 1.3:** The graph representation for the index coding problem with  $A_1 = \{2, 3\}$ ,  $A_2 = \{1\}$ , and  $A_3 = \{1, 2\}$ .

This dissertation is organized as follows. Section 2 reviews some mathematical preliminaries. In Section 3, we characterize the capacity of a general index coding problem via asymptotic expressions involving graph theoretic quantities. In Section 4, we investigate basic structural properties of index coding capacity. In Section 5, we overview performance bounds and their relationships. In Section 6, we discuss several coding schemes based on algebraic, graph-theoretic, and information-theoretic tools. In Section 7, we introduce the notion of criticality and present necessary and sufficient conditions for a problem to be critical. In

Section 8, we exploit the coding schemes and structural properties to investigate problems with small number of messages. In Section 9, we approximate the capacity for some classes of the index coding problem. In Section 10, we explore the relationship between index coding, locally recoverable distributed storage and guessing games.

Throughout the manuscript, the base of logarithm is 2.

## 1.2 Historical Remarks

The problem of broadcasting to multiple receivers with different side information was first considered in the context of satellite communication by Birk and Kol [3, 4] and later was named as index coding by Bar-Yossef, Birk, Jayram, and Kol [5]. Slightly different formulations were also studied in the work by Celebiler and Stette [6], Wyner, Wolf, and Willems [7, 8], and Yeung [9]. In addition to satellite communication, index coding has applications in diverse areas such as multimedia distribution [10], interference management [11], and coded caching [12, 13]. This problem has also been shown to be closely related to many other important problems such as network coding [14, 15, 16], locally recoverable distributed storage [17, 18, 19], guessing games on directed graphs [14, 20, 19], matroid theory [21], and zero-error capacity of channels [22].

Due to this significance, the index coding problem has been broadly studied over the past two decades. Tools from various disciplines including graph theory, coding theory, and information theory are utilized to propose numerous interesting coding schemes [3, 23, 24, 25, 26, 27, 28, 29, 30, 31, 32, 11, 33, 20, 34] as well as several performance bounds on the capacity region and the broadcast rate [25, 35, 36, 37, 38, 33]. However, the problem is still open in general and the capacity is

only known for some special cases.

Chapter 1, in full, is a reprint of the material in the paper: Fatemeh Arbab-jolfaei and Young-Han Kim, “Elements of index coding”, to be submitted to *Foundations and Trends in Communications and Information Theory*. The dissertation author was the primary investigator and author of this paper.

## 1.A Capacity Region Under Average Error Probability Criterion

Let  $X_i$  and  $\hat{X}_i$  be random variables representing the  $i$ -th message and its estimate, respectively. Assume that  $(X_1, \dots, X_n)$  is uniformly distributed over  $[q^{t_1}] \times \dots \times [q^{t_n}]$ , i.e., the messages are uniformly distributed and independent of each other. A rate tuple  $(R_1, \dots, R_n)$  is said to be *vanishing error achievable* if there exists a sequence of  $(\lceil rR_1 \rceil, \dots, \lceil rR_n \rceil, r)$  index codes such that the average probability of error

$$\mathbf{P}^{(r)}\{(\hat{X}_1, \dots, \hat{X}_n) \neq (X_1, \dots, X_n)\} \rightarrow 0 \quad (1.5)$$

as  $r \rightarrow \infty$ . The *vanishing error capacity region*  $\mathcal{C}_v$  of the index coding problem is the closure of the set of all vanishing error achievable rate tuples  $(R_1, \dots, R_n)$ .

For a general network communication problem, the vanishing error capacity region and the (zero error) capacity region are not the same [39]. However, for a single server broadcasting multiple messages these two regions are identical [40], which is rediscovered by Langberg and Effros [41] for index coding.

**Lemma 1.2** (Langberg and Effros [41]).

$$\mathcal{C} = \mathcal{C}_v.$$

One can similarly define a *vanishing error linearly achievable* rate tuple. The *vanishing error linear capacity region*  $\mathcal{C}_{L_v}$  is then defined to be the closure of the set of these rate tuples which is also the same as (zero error) linear capacity region.

**Lemma 1.3.**  $\mathcal{C}_L = \mathcal{C}_{L_v}$ .

To prove Lemma 1.3, we first prove the following.

**Lemma 1.4.** *For any linear index code, if the probability of error  $P_e > 0$ , then  $P_e = 1$ .*

*Proof:* For any linear encoder  $\phi$  there exists a matrix  $A \in \mathbb{F}_q^{r \times \sum_{i \in [n]} t_i}$  that encodes the vector of concatenated messages  $\mathbf{x} \in \mathbb{F}_q^{\sum_{i \in [n]} t_i}$  into an index  $\mathbf{y} = \mathbf{A}\mathbf{x}$ . If  $P_e > 0$ , then there exist distinct  $\mathbf{x}_1, \mathbf{x}_2 \in \mathbb{F}_q^{\sum_{i \in [n]} t_i}$  such that  $\mathbf{A}\mathbf{x}_1 = \mathbf{A}\mathbf{x}_2$  and  $\mathbf{x}_1(A_i) = \mathbf{x}_2(A_i)$  for some  $i \in [n]$ . Let  $\mathbf{x}_e = \mathbf{x}_2 - \mathbf{x}_1$ . Then  $\mathbf{x}_e \neq \mathbf{0}$  and  $\mathbf{x}_e(A_i) = \mathbf{0}$ . Then for every  $\mathbf{x}$ , there exists  $\mathbf{x}' = \mathbf{x} + \mathbf{x}_e$  for which  $\mathbf{A}\mathbf{x} = \mathbf{A}\mathbf{x}'$  and  $\mathbf{x}(A_i) = \mathbf{x}'(A_i)$  and thus the error probability is 1.  $\square$

Now we are ready to prove Lemma 1.3. Clearly  $\mathcal{C}_L \subseteq \mathcal{C}_{L_v}$ . Thus, it suffices to show that  $\mathcal{C}_{L_v} \subseteq \mathcal{C}_L$ . Let  $\mathbf{R}$  be a vanishing error linearly achievable rate tuple. Then, by definition, there exists a sequence of  $(\lceil rR_1 \rceil, \dots, \lceil rR_n \rceil, r)$  index codes for which (1.5) is satisfied. By Lemma 1.4, there exists a sufficiently large  $r$  such that the error probability of the index code  $(\lceil rR_1 \rceil, \dots, \lceil rR_n \rceil, r)$  is zero and thus,  $\mathbf{R}$  is also a (zero-error) linearly achievable rate tuple. Hence, we have  $\mathcal{C}_{L_v} \subseteq \mathcal{C}_L$ , which completes the proof.

## 1.B Proof of Lemma 1.1

Let  $\mathcal{I}$  and  $\mathcal{I}'$  be index coding instances defined over finite fields  $\mathbb{F}_q$  and  $\mathbb{F}_{q'}$ , respectively, and let  $\mathcal{A}_q$  and  $\mathcal{A}_{q'}$  be the associated sets of achievable rate tuples. We consider two cases.

Case 1:  $\log_q q'$  is a rational number, i.e.,  $\log_q q' = \frac{a}{b}$  for some  $a, b \in \mathbb{N}$ . To show that the capacity regions are equal, it suffices to show  $\mathcal{A}_q = \mathcal{A}_{q'}$ . Assume  $\mathbf{R} = (R_1, \dots, R_n) \in \mathcal{A}_q$ . Then, by definition, there exists a  $(\mathbf{t}, r)$  code for problem  $\mathcal{I}$  such that  $R_i \leq t_i/r, i \in [n]$ . Repeat the  $(\mathbf{t}, r)$  code  $a$  times to construct a  $(a\mathbf{t}, ar)$  index code for problem  $\mathcal{I}$ . Since the two instances are both defined on the same set of side information, and  $q^a = q'^b$ , this leads to a  $(b\mathbf{t}, br)$  code for problem  $\mathcal{I}'$ . Therefore,  $\mathbf{R} \in \mathcal{A}_{q'}$ , and thus  $\mathcal{A}_q \subseteq \mathcal{A}_{q'}$ . By similar steps we can show  $\mathcal{A}_{q'} \subseteq \mathcal{A}_q$ , which completes the proof.

Case 2:  $\log_q q'$  is an irrational number. First, we show that  $\mathcal{A}_{q'} \subseteq \mathcal{C}_q$ . Assume  $\mathbf{R} \in \mathcal{A}_{q'}$ . Then, by definition, there exists a  $(\mathbf{t}, r)$  index code for problem  $\mathcal{I}'$  such that  $R_i \leq t_i/r, i \in [n]$ . For any  $\delta > 0$ , there exists  $a, b \in \mathbb{N}$  such that  $a/b < \log_q q' < a/b + \delta$ . Construct a  $(b\mathbf{t}, br)$  index code for problem  $\mathcal{I}'$  by repeating the  $(\mathbf{t}, r)$  code  $b$  times. Since  $q^a < q'^b < q^{a+\delta b}$  and the two problems are defined on the same set of side information, a  $(a\mathbf{t}, (a + \delta b)r)$  code for problem  $\mathcal{I}$  can be constructed from the  $(b\mathbf{t}, br)$  code for problem  $\mathcal{I}'$ . Letting  $\delta \rightarrow 0$  proves that  $\mathbf{R} \in \mathcal{C}_q$ , and thus  $\mathcal{A}_{q'} \subseteq \mathcal{C}_q$ . Since  $\mathcal{C}_q$  is convex, we have  $\mathcal{C}_{q'} \subseteq \mathcal{C}_q$ . By similar steps we can show  $\mathcal{C}_q \subseteq \mathcal{C}_{q'}$ , which completes the proof.

# Chapter 2

## Mathematical Preliminaries

Throughout, unless specified otherwise, a graph  $G = (V, E)$  shall mean a directed, finite, and simple graph, where  $V = V(G)$  is the set of vertices (nodes) and  $E = E(G) \subseteq V \times V$  is the set of directed edges. A graph  $G = (V, E)$  is said to be *unidirectional* if  $(i, j) \in E$  implies  $(j, i) \notin E$ . Similarly,  $G$  is said to be *bidirectional* if  $(i, j) \in E$  implies  $(j, i) \in E$ . Given  $G$ , its associated undirected graph  $U = U(G)$  is defined by identifying  $V(U) = V(G)$  and  $E(U) = \{\{i, j\} : (i, j) \in E(G)\}$ . A bidirectional graph  $G$  is sometimes identified with its undirected graph. The *complement*  $\bar{G}$  of a graph  $G$  is defined by  $V(\bar{G}) = V(G)$  and  $(i, j) \in E(\bar{G})$  iff  $(i, j) \notin E(G)$ . For any  $J \subseteq V(G)$ ,  $G|_J$  denotes the subgraph induced by  $J$ , i.e.,  $V(G|_J) = J$  and  $E(G|_J) = \{(i, j) \in E : i, j \in J\}$ . A graph  $G = (V, E)$  is referred to as a *cycle* if the set of vertices  $V$  can be listed in the order  $i_1, \dots, i_{n+1}$  such that  $i_{n+1} = i_1$  and  $E = \{(i_j, i_{j+1}), j \in [n]\}$ . A graph is said to be *acyclic* if no induced subgraph is a cycle. A *tournament* is a unidirectional graph in which every pair of distinct vertices is connected by a single directed edge.

**Lemma 2.1** (Stearns [42], Erdős and Moser [43]). *Every tournament on  $n$  vertices contains an acyclic induced subgraph on  $1 + \lfloor \log_2 n \rfloor$  vertices.*

An *independent set* of a graph  $G$  is a set of vertices with no edge among them. The *independence number*  $\alpha(G)$  is the size of the largest independent set of the graph  $G$ . A *clique*  $K$  of a graph  $G$  is a set of vertices such that there is a (directed) edge from every vertex in  $K$  to every other vertex in  $K$ . Thus,  $K$  is a clique of  $G$  iff it is an independent set of  $\bar{G}$ . The *clique number*  $\omega(G)$  is the size of the largest clique of the graph  $G$ . It is easy to see that

$$\omega(G) = \alpha(\bar{G}). \quad (2.1)$$

For an undirected graph  $U$ , graph complement  $\bar{U}$ , independent set, independence number  $\alpha(U)$ , clique, and clique number  $\omega(U)$  are similarly defined and (2.1) also holds. Two vertices  $i$  and  $j$  of an undirected graph  $U$  are said to be *adjacent* if  $\{i, j\} \in E(U)$ . An *automorphism* of an undirected graph  $U$  is a bijective function  $\sigma : V(U) \rightarrow V(U)$  such that for any two vertices  $i, j \in V(U)$  we have  $\sigma(i)$  and  $\sigma(j)$  are adjacent iff  $i$  and  $j$  are adjacent. An undirected graph  $U$  is said to be *vertex transitive* if for any two vertices  $i$  and  $j$  of  $U$ , there exists an automorphism  $\sigma : V(U) \rightarrow V(U)$  such that  $\sigma(i) = j$ .

A (vertex) coloring of an undirected (finite simple) graph  $U$  is a mapping that assigns a color to each vertex such that no two adjacent vertices share the same color. The *chromatic number*  $\chi(U)$  is the minimum number of colors such that a coloring of the graph exists. More generally, a  $b$ -fold coloring assigns a set of  $b$  colors to each vertex such that no two adjacent vertices share the same color. The  $b$ -fold chromatic number  $\chi^{(b)}(U)$  is the minimum number of colors such that a  $b$ -fold coloring exists. The *fractional chromatic number* of the graph is defined as

$$\chi_f(U) = \lim_{b \rightarrow \infty} \frac{\chi^{(b)}(U)}{b} = \inf_b \frac{\chi^{(b)}(U)}{b},$$



where the limit exists by Fekete's lemma [1] since  $\chi^{(b)}(U)$  is subadditive, i.e.,  $\chi^{(b_1+b_2)}(U) \leq \chi^{(b_1)}(U) + \chi^{(b_2)}(U)$ . Consequently,

$$\chi_f(U) \leq \chi(U). \quad (2.2)$$

Let  $\mathcal{I}$  be the collection of all independent sets in  $U$ . The chromatic number and the fractional chromatic number are also characterized via the following optimization problem

$$\begin{aligned} & \text{minimize } \sum_{J \in \mathcal{I}} \rho_J \\ & \text{subject to } \sum_{J \in \mathcal{I}: i \in J} \rho_J \geq 1, \quad i \in V. \end{aligned}$$

When the optimization variables  $\rho_J$ ,  $J \in \mathcal{I}$ , take values in  $\{0, 1\}$ , then the (integral) solution to the integer programming is the chromatic number. If this constraint is relaxed and  $\rho_J \in [0, 1]$ , then the (rational) solution to this linear programming is the fractional chromatic number [44]. As no independent set contains two vertices of a clique,

$$\omega(U) \leq \chi_f(U) \leq \chi(U) \quad (2.3)$$

for any undirected graph  $U$ . The fractional chromatic number can be also related to the independence number.

**Lemma 2.2** (Scheinerman and Ullman [44]). *For any undirected graph  $U$ ,*

$$\chi_f(U) \geq \frac{|V(U)|}{\alpha(U)},$$

*with equality if the graph is vertex transitive.*

An undirected graph  $U = (V, E)$  is said to be *perfect* if for every induced subgraph  $U|_J$ ,  $J \subseteq V$ , the clique number equals the chromatic number, i.e.,  $\omega(U|_J) = \chi(U|_J)$ . Perfect graphs can be characterized as follows.

**Proposition 2.1** (Chudnovsky, Robertson, Seymour, and Thomas [45]). *An undirected graph  $U$  is perfect iff no induced subgraph of  $U$  is an odd cycle of length at least five (odd hole) or the complement of one (odd antihole).*

Let  $U = (V, E)$  be an undirected graph with  $V = [n]$ . For each clique  $K$  of  $U$ , the *incidence vector*  $\mathbf{x}(K) = (x_1(K), \dots, x_n(K))$  is defined by

$$x_i(K) = \begin{cases} 1 & \text{if } i \in K \\ 0 & \text{otherwise.} \end{cases}$$

Let  $\mathcal{K}$  be the collection of all cliques of  $U$ . The *clique polytope* of  $U$  is defined as the convex hull of the incidence vectors of cliques of  $U$ .

$$P_{\mathcal{K}}(U) = \left\{ \sum_{K \in \mathcal{K}} \alpha(K) \mathbf{x}(K) : \alpha(K) \geq 0, \forall K \text{ and } \sum_{K \in \mathcal{K}} \alpha(K) = 1 \right\}. \quad (2.4)$$

Another (convex) polytope associated with  $U$  is defined as

$$P(U) = \left\{ \mathbf{x} \in \mathbb{R}_{\geq 0}^n : \sum_{i \in I} x_i \leq 1 \text{ for all independent sets } I \right\}. \quad (2.5)$$

Since every incidence vector  $\mathbf{x} = (x_1, \dots, x_n)$  of a clique satisfies  $\sum_{i \in I} x_i \leq 1$  for an independent set  $I$ ,  $P_{\mathcal{K}}(U) \subseteq P(U)$  for every  $U$ . Lovász's perfect graph theorem states that equality holds iff  $U$  is perfect.

**Lemma 2.3** (Lovász [46]). *For any graph  $U$  the following statements are equivalent:*

- $U$  is perfect.
- $P_K(U) = P(U)$ .
- $\bar{U}$  is perfect.

We now state a result on chromatic numbers that will be useful later. The chromatic number of a graph can be upper bounded by decomposing it into smaller graphs. The proof is presented in Appendix 2.A.

**Lemma 2.4.** *Let  $U_1 = (V, E_1)$  and  $U_2 = (V, E_2)$  be two undirected graphs on the set of vertices  $V$ . Consider the graph  $U = (V, E_1 \cup E_2)$  defined on the same vertex set  $V$  in which each edge either belongs to  $E_1$  or  $E_2$ . Then  $\chi(U) \leq \chi(U_1) + \chi(U_2)$ .*

Generally speaking, a graph product is a binary operation on two (undirected) graphs  $U_1$  and  $U_2$  that produces a graph with the vertex set  $V(U_1) \times V(U_2)$  and the edge set constructed from the original edge sets according to certain rules. In the following,  $i \sim j$  denotes that there exists an edge between  $i$  and  $j$ .

Given two undirected graphs  $U_1$  and  $U_2$ , the *disjunctive (OR) product*  $U = U_1 \vee U_2$  is defined [47, 44] as  $V(U) = V(U_1) \times V(U_2)$  and  $(i_1, i_2) \sim (j_1, j_2)$  iff

$$i_1 \sim j_1 \quad \text{or} \quad i_2 \sim j_2.$$

We use the notion  $U^{\vee k}$  to denote the disjunctive product of  $k$  copies of  $U$ . The fractional chromatic number of the disjunctive product is multiplicative.

**Lemma 2.5** (Scheinerman and Ullman [44, Cor. 3.4.2]).

$$\chi_f(U_1 \vee U_2) = \chi_f(U_1)\chi_f(U_2).$$

Note that the chromatic number satisfies the following relationship [44, Prop. 3.4.4]:

$$\chi(U_1 \vee U_2) \leq \chi(U_1)\chi(U_2). \quad (2.6)$$

The chromatic and fractional chromatic numbers of the power of a graph scale in the same exponential rate.

**Lemma 2.6** (Scheinerman and Ullman [44, Cor. 3.4.3]). *For any undirected graph  $U$  we have*

$$\chi_f(U) = \lim_{k \rightarrow \infty} \sqrt[k]{\chi(U^{\vee k})} = \inf_k \sqrt[k]{\chi(U^{\vee k})}.$$

The *strong (AND) product*  $U = U_1 \boxtimes U_2$  is defined [48] by  $(i_1, i_2) \sim (j_1, j_2)$  iff

$$(i_1 = j_1 \text{ and } i_2 \sim j_2) \text{ or } (i_1 \sim j_1 \text{ and } i_2 = j_2) \text{ or } (i_1 \sim j_1 \text{ and } i_2 \sim j_2).$$

Again,  $U^{\boxtimes k}$  denotes the strong product of  $k$  copies of  $U$ . The disjunctive product and the strong product are related as follows.

**Lemma 2.7.**  $\overline{U_1 \vee U_2} = \overline{U_1} \boxtimes \overline{U_2}$ .

The *Cartesian product*  $U = U_1 \wedge U_2$  is defined by  $(i_1, i_2) \sim (j_1, j_2)$  iff

$$(i_1 = j_1 \text{ and } i_2 \sim j_2) \text{ or } (i_2 = j_2 \text{ and } i_1 \sim j_1).$$

This product does not increase the chromatic number.

**Lemma 2.8** (Sabidussi [49, Lemma 2.6]).

$$\chi(U_1 \wedge U_2) = \max\{\chi(U_1), \chi(U_2)\}.$$

The *lexicographic product*  $U = U_1 \circ U_2$  is defined [48] by  $(i_1, i_2) \sim (j_1, j_2)$  iff

$$i_1 \sim j_1 \quad \text{or} \quad (i_1 = j_1 \text{ and } i_2 \sim j_2).$$

Note that the lexicographic product of graphs is not commutative. Nonetheless, its fractional chromatic number is still multiplicative.

**Lemma 2.9** (Scheinerman and Ullman [44, Cor. 3.4.5]).

$$\chi_f(U_1 \circ U_2) = \chi_f(U_1)\chi_f(U_2).$$

The lexicographic product can also be defined for directed graphs  $G_0$  and  $G_1$ :  $((i_1, i_2), (j_1, j_2)) \in E(G_0 \circ G_1)$  iff

$$(i_1, j_1) \in E(G_0) \quad \text{or} \quad (i_1 = j_1 \text{ and } (i_2, j_2) \in E(G_1)).$$

In other words, each vertex in  $G_0$  is replaced by a copy of  $G_1$  and all vertices in one copy of  $G_1$  are connected to vertices in another copy according to  $E(G_0)$ ; see Figure 2.1.

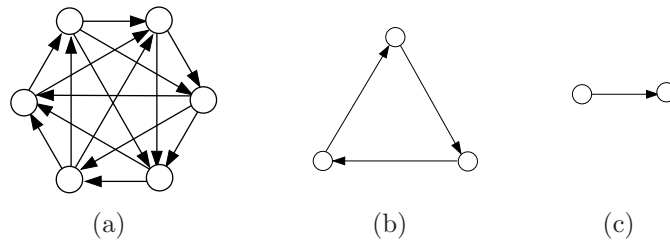

**Figure 2.1:** (a) A 6-node graph that is the lexicographic product  $G_0 \circ G_1$  of two smaller graphs  $G_0$  and  $G_1$ . (b) The 3-node graph  $G_0$ . (c) The 2-node graph  $G_1$ .

Consider a graph  $U$  whose vertices represent input symbols of a noisy channel and two vertices are connected iff the corresponding channel inputs are con-

fusable as they may result in the same channel output. The goal is to find the zero-error capacity of the channel represented by the graph  $U$ . If we are limited to use the channel only once, then we can send up to  $\lfloor \log(\alpha(U)) \rfloor$  bits without an error. However, if we are allowed to use the channel  $t$  times, then we can construct the following graph to capture the confusabilities. Assign each  $t$ -tuple of the input symbols to a vertex and the vertices for two tuples  $x^t$  and  $z^t$  connect iff for every  $i$ ,  $x_i = z_i$  or  $x_i \sim z_i$  in  $U$ . We can easily check that the resulting graph is the strong product  $U^{\boxtimes t}$ . Thus, by using the channel  $t$  times, we can send  $\lfloor \log(\alpha(U^{\boxtimes t})) \rfloor$  bits without an error. Based on this observation [50], the *Shannon capacity* of a graph  $U$  is defined as

$$\Theta(U) = \sup_t \sqrt[t]{\alpha(U^{\boxtimes t})} = \lim_{t \rightarrow \infty} \sqrt[t]{\alpha(U^{\boxtimes t})}. \quad (2.7)$$

In other words,  $\log(\Theta)$  indicates the number of bits per input symbol that can be sent through the channel without error. By definition,

$$\alpha(U) \leq \Theta(U). \quad (2.8)$$

Shannon [50] showed that for perfect graphs  $\alpha(U) = \Theta(U)$ . The equality does not hold in general, however. In fact, computing the Shannon capacity of a general graph is a very hard problem. Lovász [51] derived an upper bound on the Shannon capacity referred to as the Lovász theta function, which is easily computable and results in determining the Shannon capacity of some graphs. Before defining the Lovász theta function, we need the following definition. An *orthonormal representation* of an undirected graph  $U$  with  $n$  vertices is a set of unit vectors  $(v_1, \dots, v_n)$  such that if  $i$  and  $j$  are nonadjacent vertices of  $U$ , then  $v_i$  and  $v_j$  are orthogonal, i.e.,  $v_i^T v_j = 0$ . For example, a set of  $n$  pairwise orthogonal unit vectors

is an orthonormal representation of any undirected  $n$ -node graph. The *value* of an orthonormal representation is defined as

$$\min_{c: \|c\|=1} \max_{i \in [n]} \frac{1}{(c^T v_i)^2}.$$

The unit vector  $c$  attaining the minimum is referred to as the *handle* of the representation. The *Lovász theta function* of  $U$ , denoted as  $\vartheta(U)$ , is defined to be the minimum value over all orthonormal representations of  $U$ . A representation is said to be optimal if it attains this minimum.

**Lemma 2.10** (Lovász [51]). *For any undirected graph  $U$ ,*

$$\Theta(U) \leq \vartheta(U).$$

By (2.1), (2.8), Lemma 2.10, and Theorem 10 in [51], the Lovász theta function is sandwiched by other graph-theoretic quantities that are NP-hard to compute.

**Lemma 2.11.** *For any undirected graph  $U$ ,*

$$\omega(U) \leq \vartheta(\bar{U}) \leq \chi(U).$$

However, the Lovász theta function  $\vartheta(U)$  is polynomially computable in  $|V(U)|$  [52].

Chapter 2, in part, is a reprint of the material in the paper: Fatemeh Arbabjolfaei and Young-Han Kim, “Elements of index coding”, to be submitted to *Foundations and Trends in Communications and Information Theory*. The dissertation author was the primary investigator and author of this paper.

## 2.A Proof of Lemma 2.4

Let  $V'$  be the set of vertices incident to the edges in  $E_2 \setminus E_1$  and let  $U' = (V', E_2 \setminus E_1)$ . In order to color the vertices of  $U$ , we first color the vertices in  $V \setminus V'$  with  $\chi(U_1)$  colors using the optimal coloring for  $U_1$ . Next, we color  $U'$  with  $\chi(U_2)$  additional colors using the optimal coloring for  $U_2$ , which is valid since  $V' \subseteq V$  and  $E_2 \setminus E_1 \subseteq E_2$ . This guarantees that any pair of adjacent vertices are assigned different colors, whether both of them belong to  $V'$  or to  $V \setminus V'$  or one to each. Therefore, there exists a proper coloring of  $U$  with at most  $\chi(U_1) + \chi(U_2)$  colors and thus  $\chi(U) \leq \chi(U_1) + \chi(U_2)$ .



## Chapter 3

# Multiletter Characterization of the Capacity

The notion of confusion graph for the index coding problem was originally introduced by Alon, Hassidim, Lubetzky, Stav, and Weinstein [53]. In the context of guessing games, an equivalent notion was introduced independently by Gadouleau and Riis [54]. The use of confusion graphs in information theory traces back to the work by Shannon to characterize the zero-error capacity of a noisy channel [50] and to the work by Witsenhausen [55], and Alon and Orlitsky [56] to accurately convey information to a receiver who has some, possibly related, prior knowledge. Consider a directed graph  $G = (V, E)$  with  $V = [n]$ . Let  $A_i = \{j \in V : (j, i) \in E\}$ ,  $i \in [n]$ , and let  $\mathbf{t} = (t_1, \dots, t_n)$  be an integer  $n$ -tuple. Two binary  $n$ -tuples  $x^n, z^n \in \prod_{i \in [n]} \{0, 1\}^{t_i}$  are said to be *confusable at position  $l \in [t_i]$  of node  $i \in [n]$*  if  $x_{il} \neq z_{il}$  and  $x_j = z_j$  for all  $j \in A_i$ . Hence, if two tuples  $x^n$  and  $z^n$  are nonconfusable, then for each  $i \in [n]$  either  $x_i = z_i$  or  $x_i \neq z_i$  and  $x(A_i) \neq z(A_i)$ . If the directed graph  $G$  is the side information graph of an index coding instance, then  $x^n$  and  $z^n$  are nonconfusable implies that these

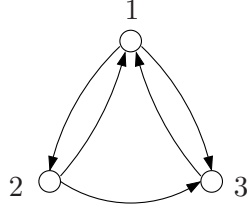

**Figure 3.1:** The graph representation for the index coding problem with  $A_1 = \{2, 3\}$ ,  $A_2 = \{1\}$ , and  $A_3 = \{1, 2\}$ .

two message tuples can be assigned to the same codeword without causing any problem in decoding. As an example, consider the index coding problem with side information graph shown in Figure 3.1. Let  $t_i = 1$ ,  $i \in [3]$ . Two message tuples  $(x_1, x_2, x_3) = (0, 0, 0)$  and  $(z_1, z_2, z_3) = (0, 1, 1)$  are confusable at position 1 of node 2. Since  $x_2 \neq z_2$  and  $x_1 = z_1$ , receiver 2 cannot correctly decode its message only based on its side information set  $A_2 = \{1\}$ .

Given a directed graph  $G$  and an integer  $n$ -tuple  $\mathbf{t} = (t_1, \dots, t_n)$ , the *confusion graph*  $\Gamma_{\mathbf{t}}^{(il)}(G)$  at position  $l$  of node  $i$  is an undirected graph with  $\prod_{i \in [n]} 2^{t_i}$  vertices such that every vertex corresponds to a binary tuple  $x^n$  and two vertices are connected iff the corresponding binary tuples are confusable at position  $l$  of node  $i$ . (see Figure 3.2(a), (b), and (c)).

Aggregating over all positions, we say that  $x^n, z^n \in \prod_{i \in [n]} \{0, 1\}^{t_i}$  are *confusable* if they are confusable at some position  $l$  of some node  $i$ . The *confusion graph*  $\Gamma_{\mathbf{t}}(G)$  is defined as before based on confusion between each pair of vertices, or equivalently,

$$E(\Gamma_{\mathbf{t}}(G)) = \bigcup_{i \in [n]} \bigcup_{l=1}^{t_i} E(\Gamma_{\mathbf{t}}^{(il)}(G)). \quad (3.1)$$

The confusion graph  $\Gamma_{\mathbf{t}}(G)$  corresponding to  $\mathbf{t} = (1, 1, 1)$  for the graph of Figure 3.1 is shown in Figure 3.2(d). If  $\mathbf{t} = (t, \dots, t)$ , then  $\Gamma_{\mathbf{t}}(G)$  is simply denoted by  $\Gamma_t(G)$ .

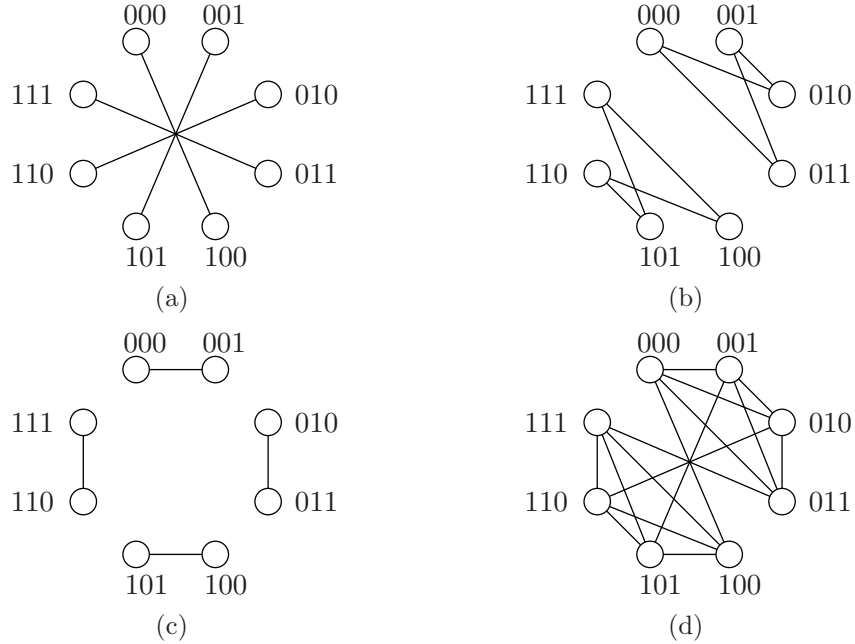

**Figure 3.2:** Confusion graphs for the directed graph  $G$  shown in Figure 3.1 corresponding to the integer tuple  $\mathbf{t} = (t_1, t_2, t_3) = (1, 1, 1)$ . (a)  $\Gamma_{\mathbf{t}}^{(11)}(G)$ . (b)  $\Gamma_{\mathbf{t}}^{(21)}(G)$ . (c)  $\Gamma_{\mathbf{t}}^{(31)}(G)$ . (d)  $\Gamma_{\mathbf{t}}(G)$ .

Alon, Hassidim, Lubetzky, Stav, and Weinstein [53] used the notion of confusion graph to characterize the broadcast rate. Assume that each message has length  $t$  bits. Consider a coloring of the vertices of the confusion graph  $\Gamma = \Gamma_t(G)$  with  $\chi(\Gamma)$  colors. This partitions the vertices of  $\Gamma$  into  $\chi(\Gamma)$  independent sets. By the definition of the confusion graph, no two message tuples in each independent set are confusable and therefore assigning a unique codeword to each independent set yields a valid index code. The total number of codewords of this index code is  $\chi(\Gamma)$ , which requires  $r = \lceil \log(\chi(\Gamma)) \rceil$  bits to be broadcast. Conversely, consider any  $(t, r)$  index code that assigns (at most)  $2^r$  distinct codewords to message tuples. By definition, all the message tuples mapped to a codeword form an independent set of the confusion graph  $\Gamma = \Gamma_t(G)$ . Moreover, every message tuple is mapped to some codeword so that these independent sets partition  $V(\Gamma)$ . Thus,  $\chi(\Gamma) \leq 2^r$ ,

or equivalently,  $r \geq \lceil \log(\chi(\Gamma)) \rceil$ .

This argument by Alon, Hassidim, Lubetzky, Stav, and Weinstein [53] characterizes the minimum number of bits to be broadcast when messages are of  $t$  bits as

$$\beta_t(G) := \inf \frac{r}{t} = \frac{1}{t} \lceil \log(\chi(\Gamma_t(G))) \rceil, \quad (3.2)$$

where the infimum is over all  $(t, r)$  zero-error index codes. Thus, the broadcast rate can be upper bounded as

$$\beta(G) \leq \frac{1}{t} \lceil \log(\chi(\Gamma_t(G))) \rceil, \quad (3.3)$$

for every positive integer  $t$ . Moreover, by taking limit

$$\beta(G) = \lim_{t \rightarrow \infty} \frac{1}{t} \log(\chi(\Gamma_t(G))). \quad (3.4)$$

Note that for any two integers  $t_1$  and  $t_2$  we have

$$E(\Gamma_{t_1+t_2}) \subseteq E(\Gamma_{t_1} \vee \Gamma_{t_2}).$$

Therefore,

$$\begin{aligned} \chi(\Gamma_{t_1+t_2}) &\leq \chi(\Gamma_{t_1} \vee \Gamma_{t_2}) \\ &\leq \chi(\Gamma_{t_1})\chi(\Gamma_{t_2}), \end{aligned} \quad (3.5)$$

where (3.5) follows by (2.6). Hence, the limit in (3.4) exists by Fekete's lemma [1]

and the subadditivity

$$\log(\chi(\Gamma_{t_1+t_2})) \leq \log(\chi(\Gamma_{t_1})) + \log(\chi(\Gamma_{t_2})).$$

It turns out that the broadcast rate can also be characterized via the *clique number* of the confusion graph as

$$\beta(G) = \lim_{t \rightarrow \infty} \frac{1}{t} \log(\omega(\Gamma_t(G))). \quad (3.6)$$

Similar to (3.4), we can argue that the limit in (3.6) exists by Fekete's lemma.

Recall that for a general graph  $\Gamma$ ,  $\omega(\Gamma) \leq \chi(\Gamma)$  so that one direction of (3.6), i.e., “ $\geq$ ” always holds. We can exploit the special structure of the confusion graph to prove the other direction. First we argue that neither  $\Gamma_{\mathbf{t}}^{(il)}$  nor its complement have any chordless cycle of length greater than four.

**Lemma 3.1.**  $\Gamma_{\mathbf{t}}^{(il)}(G)$  does not have any chordless cycle of length greater than four.

**Lemma 3.2.** The complement of  $\Gamma_{\mathbf{t}}^{(il)}(G)$  does not have any chordless cycle of length greater than four.

The proofs of the lemmas are given in Appendices 3.A and 3.B. Therefore, by Proposition 2.1 we have the following.

**Proposition 3.1.**  $\Gamma_{\mathbf{t}}^{(il)}(G)$  is perfect.

Consequently, every confusion graph  $\Gamma_{\mathbf{t}}$  is a combination of a small number of perfect graphs (see (3.1)), which implies the following.

**Proposition 3.2.** Given a directed graph  $G$  and an integer  $n$ -tuple  $\mathbf{t} = (t_1, \dots, t_n)$ ,

the confusion graph  $\Gamma_{\mathbf{t}}(G)$  satisfies

$$\chi(\Gamma_{\mathbf{t}}(G)) \leq \left( \sum_{i \in [n]} t_i \right) \omega(\Gamma_{\mathbf{t}}(G)). \quad (3.7)$$

*Proof:* Consider

$$\chi(\Gamma_{\mathbf{t}}(G)) \leq \sum_{i \in [n]} \sum_{l=1}^{t_i} \chi(\Gamma_{\mathbf{t}}^{(il)}(G)) \quad (3.8)$$

$$= \sum_{i \in [n]} \sum_{l=1}^{t_i} \omega(\Gamma_{\mathbf{t}}^{(il)}(G)) \quad (3.9)$$

$$\leq \sum_{i \in [n]} \sum_{l=1}^{t_i} \omega(\Gamma_{\mathbf{t}}(G)) \quad (3.10)$$

$$= \left( \sum_{i \in [n]} t_i \right) \omega(\Gamma_{\mathbf{t}}(G)),$$

where (3.8) follows by Lemma 2.4, (3.9) follows by Proposition 3.1, and (10.27) follows by (3.1).  $\square$

We can relate the broadcast rate to other graph theoretic quantities for the confusion graph  $\Gamma_{\mathbf{t}}$  and its complement  $\bar{\Gamma}_{\mathbf{t}}$ . For every undirected graph  $\Gamma$ , we have

$$\omega(\Gamma) = \alpha(\bar{\Gamma}) \leq \Theta(\bar{\Gamma}) \leq \vartheta(\bar{\Gamma}) \leq \chi(\Gamma), \quad (3.11)$$

where  $\Theta(\Gamma)$  and  $\vartheta(\Gamma)$  denote the Shannon capacity [50] and the Lovász theta function [51] of the undirected graph  $\Gamma$ , respectively. This chain of inequalities together with (2.3), (3.4), and (3.6) implies the following.

**Theorem 3.1.**

$$\beta(G) = \lim_{t \rightarrow \infty} \frac{1}{t} \log(\chi(\Gamma_t(G))) \quad (3.12)$$

$$= \lim_{t \rightarrow \infty} \frac{1}{t} \log(\chi_f(\Gamma_t(G))) \quad (3.13)$$

$$= \lim_{t \rightarrow \infty} \frac{1}{t} \log\left(\vartheta\left(\overline{\Gamma_t(G)}\right)\right) \quad (3.14)$$

$$= \lim_{t \rightarrow \infty} \frac{1}{t} \log\left(\Theta\left(\overline{\Gamma_t(G)}\right)\right) \quad (3.15)$$

$$= \lim_{t \rightarrow \infty} \frac{1}{t} \log(\omega(\Gamma_t(G))). \quad (3.16)$$

Equation (3.12) can be generalized to characterize the capacity region  $\mathcal{C}$  of the index coding problem in terms of the chromatic number of the confusion graph.

**Proposition 3.3.** *The capacity region  $\mathcal{C}$  of an index coding problem  $G$  with  $n$  messages is the closure of all rate tuples  $(R_1, \dots, R_n)$  such that*

$$R_i \leq \frac{t_i}{\log(\chi(\Gamma_{\mathbf{t}}(G)))}, \quad i \in [n], \quad (3.17)$$

for some  $\mathbf{t} = (t_1, \dots, t_n)$ .

We now state a stronger result, in terms of the *fractional* chromatic number. The proof is relegated to Appendix 3.C.

**Proposition 3.4.** *The capacity region  $\mathcal{C}$  of an index coding problem  $G$  with  $n$  messages is the closure of all rate tuples  $(R_1, \dots, R_n)$  such that*

$$R_i \leq \frac{t_i}{\log(\chi_f(\Gamma_{\mathbf{t}}(G)))}, \quad i \in [n], \quad (3.18)$$

for some  $\mathbf{t} = (t_1, \dots, t_n)$ .

Next, we extend the multiletter characterization in Proposition 3.4 to characterize the capacity region in terms of the clique number of the confusion graph asymptotically which will prove to be useful in establishing structural properties of the capacity region. See Appendix 3.D for the proof.

**Theorem 3.2.** *The capacity region  $\mathcal{C}$  of an index coding problem  $G$  with  $n$  messages is the closure of all rate tuples  $(R_1, \dots, R_n)$  such that*

$$R_i \leq \lim_{k \rightarrow \infty} \frac{kt_i}{\log(\omega(\Gamma_{kt}(G)))}, \quad i \in [n], \quad (3.19)$$

for some  $\mathbf{t} = (t_1, \dots, t_n)$ .

We can also establish a nonasymptotic upper bound on the broadcast rate via the Shannon capacity and the Lovász theta function of the confusion graph; see Appendix 3.E for the proof.

**Proposition 3.5.** *For any side information graph  $G$  and any positive integer  $t$ ,*

$$\beta(G) \leq \frac{1}{t} \log \left( \Theta \left( \overline{\Gamma_t(G)} \right) \right) \quad (3.20)$$

$$\leq \frac{1}{t} \log \left( \vartheta \left( \overline{\Gamma_t(G)} \right) \right). \quad (3.21)$$

By (3.11), the bounds in (3.20) and (3.21) are tighter than the upper bound in (3.3). Unlike the chromatic number and the Shannon capacity, the Lovász theta function can be computed in polynomial time in the number of vertices of the confusion graph (see [52]).

Chapter 3, in part, is a reprint of the material in the papers: Fatemeh Arbabjolfaei and Young-Han Kim, “Structural properties of index coding capacity using fractional graph theory”, *Proceedings of the IEEE International Symposium on Information Theory*, Hong Kong, June 2015; and Fatemeh Arbabjolfaei and



Young-Han Kim, “Generalized lexicographic products and the index coding capacity”, submitted to *IEEE Transactions on Information Theory*; and Fatemeh Arbabjolfaei and Young-Han Kim, “Elements of index coding”, to be submitted to *Foundations and Trends in Communications and Information Theory*. The dissertation author was the primary investigator and author of these papers.

### 3.A Proof of Lemma 3.1

It suffices to show that every cycle of length greater than four has a chord. Let  $v_1^n, v_2^n, \dots, v_k^n$  be the vertices (each associated with an  $n$ -message tuple) of a length- $k$  cycle of  $\Gamma_{\mathbf{t}}^{(il)}(G)$  for  $k \geq 5$ . Then  $v_1^n \sim v_2^n, v_2^n \sim v_3^n, \dots, v_{k-1}^n \sim v_k^n$ . Therefore,  $v_{1i}(l) \neq v_{2i}(l), v_{2i}(l) \neq v_{3i}(l), \dots, v_{(k-1)i}(l) \neq v_{ki}(l)$ , and  $v_{1,A_i} = v_{2,A_i} = \dots = v_{k,A_i}$ . If  $v_{1i}(l) \neq v_{3i}(l)$ , then since  $v_{1,A_i} = v_{3,A_i}$ , we have  $v_1^n \sim v_3^n$  and the length- $k$  cycle has a chord. Otherwise, since  $v_{1i}(l) = v_{3i}(l) \neq v_{4i}(l)$  and  $v_{1,A_i} = v_{4,A_i}$ , we have  $v_1^n \sim v_4^n$  and again the cycle has a chord.

### 3.B Proof of Lemma 3.2

It suffices to show that every cycle of length greater than four has a chord. Let  $v_1^n, v_2^n, \dots, v_k^n$  be the vertices of a length- $k$  cycle of  $\bar{\Gamma} = \overline{\Gamma_{\mathbf{t}}^{(il)}(G)}$  for  $k \geq 5$ . Then  $v_1^n \sim v_2^n, v_2^n \sim v_3^n, \dots, v_{k-1}^n \sim v_k^n$  in  $\bar{\Gamma}$ . If  $v_{1i}(l) = \dots = v_{ki}(l)$ , then  $v_1^n, v_2^n, \dots, v_k^n$  form a clique in  $\bar{\Gamma}$  and thus the cycle is not chordless. Hence, assume without loss of generality that  $v_{1i}(l) \neq v_{2i}(l)$ , which implies  $v_{1,A_i} \neq v_{2,A_i}$ . We now consider two cases.

Case 1 ( $v_{2i}(l) = v_{3i}(l)$ ): In this case, if  $v_{1,A_i} \neq v_{3,A_i}$ , then  $v_1^n \sim v_3^n$  in  $\bar{\Gamma}$  and the length- $k$  cycle has a chord. Suppose  $v_{1,A_i} = v_{3,A_i}$  and consider  $v_{4i}(l)$ . If  $v_{4i}(l) = v_{2i}(l)$ , then  $v_2^n \sim v_4^n$  in  $\bar{\Gamma}$  which is a chord for the length- $k$  cycle.

Suppose  $v_{4i}(l) \neq v_{2i}(l)$ . Then, since  $v_3^n \sim v_4^n$  in  $\bar{\Gamma}$  we have  $v_{3,A_i} \neq v_{4,A_i}$  and hence  $v_{1,A_i} \neq v_{4,A_i}$ . Therefore,  $v_1^n \sim v_4^n$  in  $\bar{\Gamma}$  and the length- $k$  cycle has a chord.

Case 2 ( $v_{2i}(l) \neq v_{3i}(l)$ ): In this case, if  $v_{1i}(l) = v_{3i}(l)$ , then  $v_1^n \sim v_3^n$  in  $\bar{\Gamma}$  which is a chord. Suppose  $v_{1i}(l) \neq v_{3i}(l)$ . If  $v_{1,A_i} \neq v_{3,A_i}$ , then  $v_1^n \sim v_3^n$  in  $\bar{\Gamma}$  which is a chord. Suppose  $v_{1,A_i} = v_{3,A_i}$ . If  $v_{3i}(l) = v_{4i}(l)$ , then the situation will be the same as case 1. Otherwise, we have  $v_{3,A_i} \neq v_{4,A_i}$  which implies  $v_{1,A_i} \neq v_{4,A_i}$  and thus  $v_1^n \sim v_4^n$  in  $\bar{\Gamma}$  which is a chord.

### 3.C Proof of Proposition 3.4

The necessity follows by (2.2) and Proposition 3.3.

Let  $\epsilon > 0$ . For each  $\mathbf{t} = (t_1, \dots, t_n)$  and the corresponding confusion graph  $\Gamma_{\mathbf{t}}(G)$ , Lemma 2.6 implies that there exists an integer  $k$  such that

$$\sqrt[k]{\chi(\Gamma_{\mathbf{t}}^k(G))} \leq \chi_f(\Gamma_{\mathbf{t}}(G)) + \epsilon. \quad (3.22)$$

It can be also checked that the set of edges of  $\Gamma_{\mathbf{t}}^k(G)$  contains the set of edges of  $\Gamma_{k\mathbf{t}}(G)$ , which, when combined with (3.22), implies that  $\sqrt[k]{\chi(\Gamma_{k\mathbf{t}}(G))} \leq \chi_f(\Gamma_{\mathbf{t}}(G)) + \epsilon$ , or equivalently,

$$\frac{t_i}{\log(\chi_f(\Gamma_{\mathbf{t}}(G)) + \epsilon)} \leq \frac{kt_i}{\log(\chi(\Gamma_{k\mathbf{t}}(G)))}, \quad i \in [n].$$

Thus, by Proposition 3.3, if  $(R_1, \dots, R_n)$  satisfies

$$R_i \leq \frac{t_i}{\log(\chi_f(\Gamma_{\mathbf{t}}(G)) + \epsilon)}, \quad i \in [n],$$

then it must be in the capacity region. Since  $\mathcal{C}$  is closed, taking  $\epsilon \rightarrow 0$  completes

the proof.

### 3.D Proof of Theorem 3.2

First note that by (2.3) and Proposition 3.2,

$$\lim_{k \rightarrow \infty} \frac{kt_i}{\log(\omega(\Gamma_{kt}(G)))} = \lim_{k \rightarrow \infty} \frac{kt_i}{\log(\chi_f(\Gamma_{kt}(G)))}. \quad (3.23)$$

*Sufficiency.* Let  $(R_1, \dots, R_n)$  be a rate tuple satisfying (3.19). Then, by (3.23),

$$R_i \leq \lim_{k \rightarrow \infty} \frac{kt_i}{\log(\chi_f(\Gamma_{kt}(G)))}, \quad i \in [n].$$

This implies that for any  $\epsilon > 0$  there exists a sufficiently large  $k$  such that

$$R_i \leq \frac{kt_i}{\log(\chi_f(\Gamma_{kt}(G)))} + \epsilon, \quad i \in [n],$$

and thus, by Proposition 3.4,  $(R_1, \dots, R_n) \in \mathcal{C}$ .

*Necessity.* Let  $(R_1, \dots, R_n) \in \mathcal{C}$ . Then, by Proposition 3.4, for any  $\epsilon > 0$  there exists a vector  $\mathbf{t}$  such that for all  $i \in [n]$ ,

$$R_i \leq \frac{t_i}{\log(\chi_f(\Gamma_{\mathbf{t}}(G)))} + \epsilon \quad (3.24)$$

$$= \frac{kt_i}{\log(\chi_f(\Gamma_{\mathbf{t}}^{\vee k}(G)))} + \epsilon \quad (3.25)$$

$$\leq \frac{kt_i}{\log(\chi_f(\Gamma_{kt}(G)))} + \epsilon, \quad (3.26)$$

where (3.25) follows by Lemma 2.5 and (3.26) holds since  $E(\Gamma_{kt}(G)) \subseteq E(\Gamma_{\mathbf{t}}^{\vee k}(G))$ .

The inequality (3.26) holds for all  $k$ . Therefore, for any  $\epsilon > 0$  there exists a vector  $\mathbf{t}$  such that

$$R_i \leq \lim_{k \rightarrow \infty} \frac{kt_i}{\log(\chi_f(\Gamma_{kt}(G)))} + \epsilon, \quad i \in [n].$$

This together with (3.23) completes the proof of the converse.

### 3.E Proof of Proposition 3.5

Consider

$$\omega(\Gamma_{tk}) \leq \omega(\Gamma_t^{\vee k}) = \alpha(\overline{\Gamma_t^{\vee k}}) = \alpha(\overline{\Gamma_t^{\boxtimes k}}), \quad (3.27)$$

where the inequality holds since the set of edges of  $\Gamma_t^{\vee k}$  contains the set of edges of  $\Gamma_{tk}$ , and the last equality follows by Lemma 2.7. Now for any  $t$ ,

$$\beta(G) = \lim_{k \rightarrow \infty} \frac{\log(\omega(\Gamma_k))}{k} \quad (3.28)$$

$$= \lim_{k \rightarrow \infty} \frac{\log(\omega(\Gamma_{tk}))}{tk} \quad (3.29)$$

$$\leq \lim_{k \rightarrow \infty} \frac{\log(\alpha(\overline{\Gamma_t^{\boxtimes k}}))}{tk} \quad (3.30)$$

$$\begin{aligned} &= \lim_{k \rightarrow \infty} \frac{\log\left(\sqrt[k]{\alpha(\overline{\Gamma_t^{\boxtimes k}})}\right)}{t} \\ &= \frac{1}{t} \log\left(\lim_{k \rightarrow \infty} \sqrt[k]{\alpha(\overline{\Gamma_t^{\boxtimes k}})}\right) \\ &= \frac{1}{t} \log(\Theta(\overline{\Gamma}_t)), \end{aligned} \quad (3.31)$$

where (3.28) follows by (3.16), (3.29) holds since the limit of a subsequence is equal to the limit of the sequence, (3.30) follows by (3.27), and (3.31) follows by the definition of the Shannon capacity in (2.7). Note that for any undirected graph  $U$  we have

$$\alpha(U^{\boxtimes(k_1+k_2)}) \geq \alpha(U^{k_1})\alpha(U^{k_2}).$$

Thus, the limit in (3.30) exists by Fekete's lemma and the superadditivity

$$\log \left( \alpha \left( \bar{\Gamma}_t^{\boxtimes(k_1+k_2)} \right) \right) \geq \log \left( \alpha \left( \bar{\Gamma}_t^{k_1} \right) \right) + \log \left( \alpha \left( \bar{\Gamma}_t^{k_2} \right) \right).$$

This completes the proof of (3.20). The upper bound in (3.21) follows by Lemma 2.10.

# Chapter 4

## Structural Properties of Index Coding Capacity

In this section, we apply the multiletter characterizations of the capacity in the previous section to derive the basic properties of the capacity. We start with examples in which side information graphs can be decomposed into two parts with no, one-way, complete one-way, or complete two-way interaction (see Figure 4.1) and show that the capacity of such problems can be expressed as a simple function of the capacities of the subproblems. To characterize the capacity for all these cases in a unified manner, we introduce a new notion of graph product as follows. Suppose that  $G_0$  is a graph with vertex set  $V(G_0) = [m]$ . The *generalized lexicographic product*  $G = G_0 \circ (G_1, \dots, G_m)$  is defined by  $V(G) = \cup_{i=1}^m V(G_i)$  and  $E(G)$  consisting of  $(i, j)$  such that

$$i, j \in V(G_k) \text{ for some } k \text{ and } (i, j) \in E(G_k),$$

or

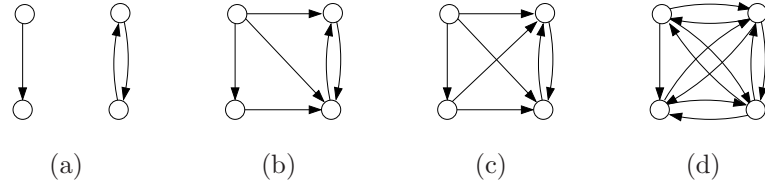

**Figure 4.1:** Graph examples with (a) no interaction, (b) one-way interaction, (c) complete one-way interaction, and (d) complete two-way interaction among its two parts.

$$i \in V(G_k), j \in V(G_l) \text{ for some } k \neq l \text{ and } (k, l) \in E(G_0).$$

In other words, vertex  $i \in V(G_0)$  is replaced by a copy of  $G_i$  and every vertex in the copy of  $G_k$  is connected to every vertex in the copy of  $G_l$  according to  $E(G_0)$  (see Figure 4.2). Note that if  $G_1 = \dots = G_m$ , then the generalized lexicographic product recovers the lexicographic product as a special case, i.e.,  $G_0 \circ (G_1, \dots, G_1) = G_0 \circ G_1$ .

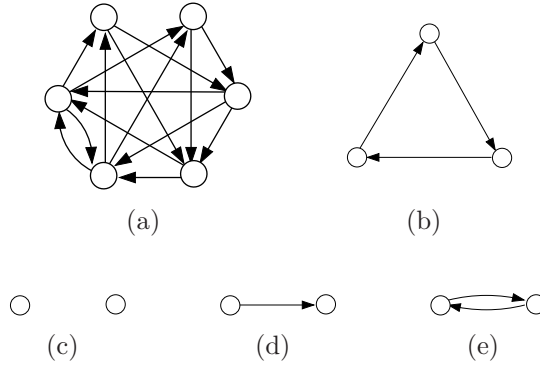

**Figure 4.2:** (a) A 6-node graph that is the generalized lexicographic product  $G_0 \circ (G_1, G_2, G_3)$  (b) The 3-node graph  $G_0$  (c) The 2-node graph  $G_1$  (d) The 2-node graph  $G_2$  (e) The 2-node graph  $G_3$ .

More concretely, suppose that  $G_1$  and  $G_2$  are two vertex-induced subgraphs of  $G$  such that  $V(G_1) = [n_1]$  and  $V(G_2) = [n_1 + 1 : n] := \{n_1 + 1, \dots, n\}$  partition  $V(G) = [n]$  and  $G$  has no edge between  $V(G_1)$  and  $V(G_2)$  (see Figure 4.1(a)). Then

$G$  can be viewed as  $G_0 \circ (G_1, G_2)$ , where  $G_0$  is the two-node graph in Figure 4.3(a). Consider a message tuple  $x^n = (\mathbf{x}_1, \mathbf{x}_2)$ , where  $\mathbf{x}_1 \in \{0, 1\}^{tn_1}$  corresponds to the index coding problem  $G_1$  and  $\mathbf{x}_2 \in \{0, 1\}^{t(n-n_1)}$  corresponds to the index coding problem  $G_2$ . Similarly consider another message tuple  $z^n = (\mathbf{z}_1, \mathbf{z}_2)$ , where  $\mathbf{z}_1$  and  $\mathbf{z}_2$  correspond to  $G_1$  and  $G_2$ , respectively. By the definition of confusability,  $x^n$  and  $z^n$  are confusable iff they are confusable at some receiver  $i \in V(G_1)$  or confusable at some receiver  $i \in V(G_2)$ . Since there is no edge between  $G_1$  and  $G_2$ , these “local” confusability conditions are equivalent to the confusability of  $\mathbf{x}_1$  and  $\mathbf{z}_1$  for the subproblem  $G_1$  and the confusability of  $\mathbf{x}_2$  and  $\mathbf{z}_2$  for the subproblem  $G_2$ , respectively. Thus,  $x^n$  and  $z^n$  are confusable for  $G$  iff  $\mathbf{x}_1$  and  $\mathbf{z}_1$  are confusable for  $G_1$  or  $\mathbf{x}_2$  and  $\mathbf{z}_2$  are confusable for  $G_2$ . By the definitions of confusion graph and disjunctive product,  $\Gamma_t(G) = \Gamma_t(G_1) \vee \Gamma_t(G_2)$ . Now by Lemma 2.5,

$$\log(\chi_f(\Gamma_t(G))) = \log(\chi_f(\Gamma_t(G_1))) + \log(\chi_f(\Gamma_t(G_2))),$$

which, along with Theorem 3.1, implies that

$$\begin{aligned} \beta(G) &= \lim_{t \rightarrow \infty} \frac{1}{t} \log(\chi_f(\Gamma_t(G))) \\ &= \lim_{t \rightarrow \infty} \frac{1}{t} \log(\chi_f(\Gamma_t(G_1))) + \lim_{t \rightarrow \infty} \frac{1}{t} \log(\chi_f(\Gamma_t(G_2))) \\ &= \beta(G_1) + \beta(G_2). \end{aligned} \tag{4.1}$$

In words, the broadcast rate is additive in those of subproblems with no interaction, which is not surprising.

**Example 4.1.** The side information graph  $G$  shown in Figure 4.1(a), is vertex-partitioned by two-node subgraphs  $G_1$  and  $G_2$  with one edge and two edges, respectively. The subgraphs  $G_1$  and  $G_2$  can be further partitioned by two one-node



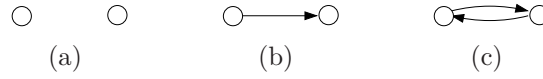

**Figure 4.3:** (a) A two-node graph with no edge, (b) a two-node graph with one edge, (c) a two-node graph with two edges.

subgraphs with (complete) one-way and complete two-way interactions, respectively. Thus, as we will see shortly,  $\beta(G_1) = 1 + 1 = 2$  (see (4.2)) and  $\beta(G_2) = \max\{1, 1\} = 1$  (see (4.7)). Therefore, by (4.1) we have  $\beta(G) = \beta(G_1) + \beta(G_2) = 3$ .

**Example 4.2.** If  $G = (V, E)$  with  $E = \emptyset$ , then by using (4.1) inductively, we have  $\beta(G) = |V|$ .

Next, consider a graph  $G$  vertex-partitioned by subgraphs  $G_1$  and  $G_2$  such that there exists an edge from every vertex in  $G_1$  to every vertex in  $G_2$  and no edge from  $G_2$  to  $G_1$  (see Figure 4.1(b)). Then  $G$  can be viewed as  $G = G_0 \circ (G_1, G_2)$ , where  $G_0$  is the two-node graph in Figure 4.3(b). Since every vertex in  $G_2$  has every vertex (message) in  $G_1$  as side information and no vertex in  $G_1$  has any vertex in  $G_2$  as side information,  $x^n = (\mathbf{x}_1, \mathbf{x}_2)$  and  $z^n = (\mathbf{z}_1, \mathbf{z}_2)$  are confusable for  $G$  iff  $\mathbf{x}_1$  and  $\mathbf{z}_1$  are confusable for  $G_1$ , or  $\mathbf{x}_1 = \mathbf{z}_1$  and  $\mathbf{x}_2$  and  $\mathbf{z}_2$  are confusable for  $G_2$ . By the definitions of confusion graph and lexicographic product,  $\Gamma_{\mathbf{t}}(G) = \Gamma_{\mathbf{t}_1}(G_1) \circ \Gamma_{\mathbf{t}_2}(G_2)$ . Thus, by Lemma 2.9 and Theorem 3.1,

$$\log(\chi_f(\Gamma_{\mathbf{t}}(G))) = \log(\chi_f(\Gamma_{\mathbf{t}_1}(G_1))) + \log(\chi_f(\Gamma_{\mathbf{t}_2}(G_2)))$$

and

$$\beta(G) = \lim_{t \rightarrow \infty} \frac{1}{t} \log(\chi_f(\Gamma_t(G))) = \beta(G_1) + \beta(G_2). \quad (4.2)$$

**Example 4.3.** For the side information graph  $G$  shown in Figure 4.1(b) we have

$$\beta(G) = \beta(G_1) + \beta(G_2) = 3.$$

As a generalization of both (4.1) and (4.2), consider a graph  $G$  vertex-partitioned by subgraphs  $G_1$  and  $G_2$  for which there exists no edge from  $G_2$  to  $G_1$ , while there may be some edge from  $G_1$  to  $G_2$  (see Figure 4.1(c)). Then,  $\beta(G)$  can be sandwiched as  $\beta(G'') \leq \beta(G) \leq \beta(G')$ , where  $G'$  is the graph with no edge between  $V(G_1)$  and  $V(G_2)$ , whereas  $G''$  is the graph for which there is an edge from every vertex in  $G_1$  to every vertex in  $G_2$  but there is no edge from  $G_2$  to  $G_1$ . Thus, by (4.1) and (4.2),

$$\beta(G) = \beta(G_1) + \beta(G_2). \quad (4.3)$$

**Example 4.4.** For the side information graph  $G$  shown in Figure 4.1(c) we have  $\beta(G) = \beta(G_1) + \beta(G_2) = 3$ .

Now suppose the graph  $G$  can be vertex-partitioned by  $m$  subgraphs  $G_1, \dots, G_m$ , such that if  $i < j$  there exists no edge from  $G_j$  to  $G_i$ , while there may be some edge from  $G_i$  to  $G_j$ . Therefore,  $G$  can be partitioned into two graphs  $(G_1, \dots, G_{m-1})$  and  $G_m$  with no edges from the latter to the former. Hence, by (4.3),

$$\beta(G) = \beta((G_1, \dots, G_{m-1})) + \beta(G_m).$$

Since  $(G_1, \dots, G_j)$ ,  $j \in \{2, \dots, m-1\}$ , can also be further partitioned by two subgraphs with one-way interaction, by repeating the same argument we have the following.

**Proposition 4.1.** *Let  $G$  be a graph that can be vertex-partitioned by  $m$  subgraphs  $G_1, \dots, G_m$ , such that if  $i < j$  there exists no edge from  $G_j$  to  $G_i$ , while there may*

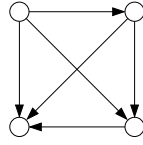

**Figure 4.4:** A 4-node acyclic graph.

be some edge from  $G_i$  to  $G_j$ . Then

$$\beta(G) = \beta(G_1) + \cdots + \beta(G_m). \quad (4.4)$$

In particular, if  $G_0$  is an acyclic directed graph with  $V(G_0) = [m]$ ,

$$\beta(G_0 \circ (G_1, \dots, G_m)) = \beta(G_1) + \cdots + \beta(G_m). \quad (4.5)$$

**Remark 4.1.** Let  $G$  be a graph as described in Proposition 4.1. Equation (4.4) can be generalized to characterize the capacity region  $\mathcal{C}$  of the index coding problem  $G$  as

$$\mathcal{C} = \left\{ (\alpha_1 \mathbf{R}_1, \dots, \alpha_m \mathbf{R}_m) : \mathbf{R}_i \in \mathcal{C}_i, i \in [m], \sum_{i=1}^m \alpha_i \leq 1 \right\}. \quad (4.6)$$

In other words, in this case, the capacity region of  $G$  is achieved by time division between the optimal coding schemes for subproblems  $G_1, \dots, G_m$ .

**Example 4.5.** For the index coding problem  $G$  with side information graph depicted in Figure 4.4 we have  $\beta(G) = 4$ . In general, if  $G$  is acyclic, then  $\beta(G) = |V(G)|$ .

Next, consider a graph  $G$  vertex-partitioned by subgraphs  $G_1$  and  $G_2$  such that there are edges from every vertex in  $G_1$  to every vertex in  $G_2$  and vice versa. Then  $G$  can be viewed as  $G = G_0 \circ (G_1, G_2)$ , where  $G_0$  is the two-node graph in

Figure 4.3(c). Since every vertex in  $G_1$  has every message in  $G_2$  as side information and every vertex in  $G_2$  has every message in  $G_1$  as side information,  $x^n = (\mathbf{x}_1, \mathbf{x}_2)$  and  $z^n = (\mathbf{z}_1, \mathbf{z}_2)$  are confusable for  $G$  iff  $\mathbf{x}_1 = \mathbf{z}_1$  and  $\mathbf{x}_2$  and  $\mathbf{z}_2$  are confusable for  $G_2$ , or  $\mathbf{x}_2 = \mathbf{z}_2$  and  $\mathbf{x}_1$  and  $\mathbf{z}_1$  are confusable for  $G_1$ . By the definitions of confusion graph and cartesian product,  $\Gamma_{\mathbf{t}}(G) = \Gamma_{\mathbf{t}_1}(G_1) \wedge \Gamma_{\mathbf{t}_2}(G_2)$ . Thus, by Lemma 2.8 and (3.4),

$$\chi(\Gamma_{\mathbf{t}}(G)) = \max\{\chi(\Gamma_{\mathbf{t}_1}(G_1)), \chi(\Gamma_{\mathbf{t}_2}(G_2))\}$$

and

$$\beta(G) = \lim_{t \rightarrow \infty} \frac{1}{t} \log(\chi(\Gamma_t(G))) = \max\{\beta(G_1), \beta(G_2)\}. \quad (4.7)$$

**Example 4.6.** For the side information graph  $G$  shown in Figure 4.1(d) we have  $\beta(G) = \max\{\beta(G_1), \beta(G_2)\} = 2$ .

Now suppose  $G_0$  is a complete graph with  $m$  vertices. Then,  $G_0 \circ (G_1, \dots, G_m)$  can be partitioned into two graphs  $G_0|_{[m-1]} \circ (G_1, \dots, G_{m-1})$  and  $G_m$  with complete two-way interaction among the two parts. Hence, by (4.7),

$$\beta(G_0 \circ (G_1, \dots, G_m)) = \max\{\beta(G_0|_{[m-1]} \circ (G_1, \dots, G_{m-1})), \beta(G_m)\}.$$

Since  $G_0|_{[j]}$ ,  $j \in [m-1]$ , is also complete, by repeating the same argument we have the following.

**Proposition 4.2.** *Let  $G_0$  be a complete graph with  $m$  vertices. Then*

$$\beta(G_0 \circ (G_1, \dots, G_m)) = \max\{\beta(G_1), \dots, \beta(G_m)\}. \quad (4.8)$$

**Remark 4.2.** Let  $G_0$  be a complete graph with  $m$  vertices. Equation (4.8) can

be generalized to characterize the capacity region  $\mathcal{C}$  of the index coding problem  $G_0 \circ (G_1, \dots, G_m)$  as

$$\mathcal{C} = \{(\mathbf{R}_1, \dots, \mathbf{R}_m) : \mathbf{R}_i \in \mathcal{C}_i, i \in [m]\}. \quad (4.9)$$

In other words, the capacity region of  $G_0 \circ (G_1, \dots, G_m)$  is achieved by simultaneously using the optimal coding schemes for  $G_1, \dots, G_m$ .

We now consider the generalized lexicographic product  $G = G_0 \circ (G_1, \dots, G_m)$  with an arbitrary directed graph  $G_0$  with  $m$  vertices.

**Theorem 4.1.** *Let  $G_0 = ([m], E)$  be a directed graph with  $m$  vertices and denote its capacity region by  $\mathcal{C}_0$ . Let  $G_1, \dots, G_m$  be  $m$  directed graphs with capacity regions  $\mathcal{C}_1, \dots, \mathcal{C}_m$ , respectively. The capacity region  $\mathcal{C}$  of the generalized lexicographic product  $G = G_0 \circ (G_1, \dots, G_m)$  is characterized as*

$$\mathcal{C} = \{(\alpha_1 \mathbf{R}_1, \dots, \alpha_m \mathbf{R}_m) : \mathbf{R}_i \in \mathcal{C}_i, i \in [m], (\alpha_1, \dots, \alpha_m) \in \mathcal{C}_0\}. \quad (4.10)$$

**Remark 4.3.** Since  $\mathcal{C}_0, \mathcal{C}_1, \dots, \mathcal{C}_m$  are compact, so is  $\mathcal{C}(G)$ .

**Remark 4.4.** If  $\mathcal{C}_0, \mathcal{C}_1, \dots, \mathcal{C}_m$  are polytopes of the form  $\mathcal{C}_i = \{\mathbf{R} : A_i \mathbf{R} \leq \mathbf{1}\}$ ,  $i = 0, 1, \dots, m$ , then  $\mathcal{C}$  is also a polytope characterized by Fourier–Motzkin elimination of  $m$  variables  $\boldsymbol{\alpha} = (\alpha_1, \dots, \alpha_m)$  from the linear inequalities

$$A_i \mathbf{R}_i \leq \alpha_i, \quad i \in [m]$$

$$A_0 \boldsymbol{\alpha} \leq \mathbf{1}.$$

Achievability of (4.10) is based on constructing a code for problem  $G$  by concatenating the index codes for problems  $G_1, \dots, G_m$  as the inner codes and

the index code for problem  $G_0$  as the outer code (see Figure 4.5). The proof of the converse is based on the clique number characterization of the capacity region in Theorem 3.2 and the following lemma. The proof of the lemma is based on a construction of a code for  $G_0$  from a code for  $G$  and is presented in Appendix 4.A.

**Lemma 4.1.** *If the rate tuple  $\left(\frac{\mathbf{t}_1}{r}, \dots, \frac{\mathbf{t}_m}{r}\right)$  is achievable for index coding problem  $G_0 \circ (G_1, \dots, G_m)$ ,*

$$\frac{1}{r}([\log(\omega(\Gamma_{\mathbf{t}_1}(G_1)))], \dots, [\log(\omega(\Gamma_{\mathbf{t}_m}(G_m)))]) \in \mathcal{C}_0.$$

The proof of Theorem 4.1 is presented in details in Appendix 4.B. The following corollary, which is a generalization of the results of Remark 4.1 and Remark 4.2, extends application of Theorem 4.1 beyond index coding instances with side information graph in the form of generalized lexicographic product.

**Corollary 4.1.** For  $i = 0, 1, \dots, m$ , let  $G'_i$  and  $G''_i$  be side information graphs of index coding problems such that  $V(G'_i) = V(G''_i)$ ,  $E(G'_i) \subseteq E(G''_i)$ , and  $\mathcal{C}(G'_i) = \mathcal{C}(G''_i) = \mathcal{C}_i$ . Suppose that  $|V(G'_0)| = |V(G''_0)| = m$  and let

$$G' = G'_0 \circ (G'_1, \dots, G'_m)$$

and

$$G'' = G''_0 \circ (G''_1, \dots, G''_m).$$

Then the capacity region of any index coding problem  $G$  such that

$$V(G) = V(G') = V(G'')$$

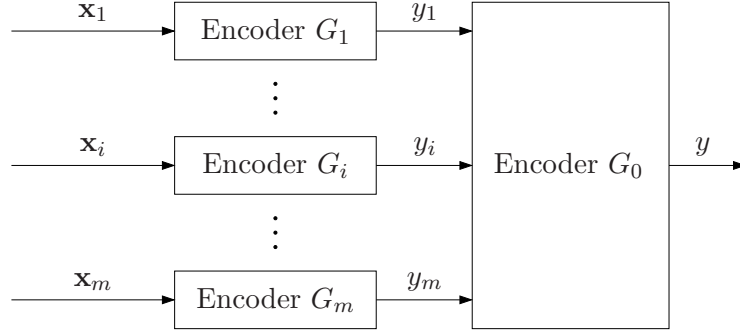

**Figure 4.5:** Construction of an index code for index coding problem  $G_0 \circ (G_1, \dots, G_m)$  by concatenating the index codes for problems  $G_1, \dots, G_m$  as the inner codes and the index code for problem  $G_0$  as the outer code.

and

$$E(G') \subseteq E(G) \subseteq E(G'')$$

is

$$\begin{aligned} \mathcal{C}(G) &= \mathcal{C}(G') \\ &= \mathcal{C}(G'') \\ &= \{(\alpha_1 \mathbf{R}_1, \dots, \alpha_m \mathbf{R}_m) : \mathbf{R}_i \in \mathcal{C}_i, i \in [m], (\alpha_1, \dots, \alpha_m) \in \mathcal{C}_0\}. \end{aligned} \quad (4.11)$$

Setting  $G_1 = \dots = G_m$  in Theorem 4.1, we see that the broadcast rate is multiplicative under the lexicographic product of index coding side information graphs.

**Corollary 4.2.** For any two directed graphs  $G_0$  and  $G_1$ ,

$$\beta(G_0 \circ G_1) = \beta(G_0)\beta(G_1).$$

The following demonstrates an application of Theorem 4.1.

**Example 4.7.** The graph in Fig. 4.6(a) can be viewed as the lexicographic product

$G = G_0 \circ G_1$  of two smaller graphs  $G_0$  and  $G_1$  in Fig. 4.6(b) and 4.6(c), respectively, with  $\beta(G_0) = 2$  and  $\beta(G_1) = 2$ . Hence, by Theorem 4.1,  $\beta(G) = \beta(G_0)\beta(G_1) = 4$ .

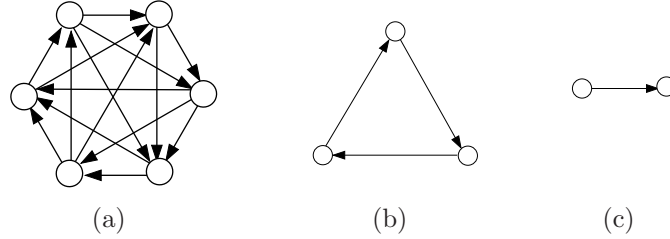

**Figure 4.6:** (a) A 6-node graph that is the lexicographic product  $G_0 \circ G_1$  of two smaller graphs  $G_0$  and  $G_1$ . (b) The 3-node graph  $G_0$ . (c) The 2-node graph  $G_1$ .

Chapter 4, in full, is a reprint of the material in the papers: Fatemeh Arbabjolfaei and Young-Han Kim, “Structural properties of index coding capacity using fractional graph theory”, *Proceedings of the IEEE International Symposium on Information Theory*, Hong Kong, June 2015; and Fatemeh Arbabjolfaei and Young-Han Kim, “Generalized lexicographic products and the index coding capacity”, submitted to *IEEE Transactions on Information Theory*; and Fatemeh Arbabjolfaei and Young-Han Kim, “Elements of index coding”, to be submitted to *Foundations and Trends in Communications and Information Theory*. The dissertation author was the primary investigator and author of these papers.

## 4.A Proof of Lemma 4.1

For  $i \in [m]$  let  $\Gamma_i = \Gamma_{\mathbf{t}_i}(G_i)$ . Let  $K_i = \{y_1, y_2, \dots, y_{|K_i|}\}$  be a maximum clique in  $\Gamma_i$  and let  $k_i = \lfloor \log(|K_i|) \rfloor = \lfloor \log(\omega(\Gamma_i)) \rfloor$ . It suffices to show that given any  $(\mathbf{t}_1, \dots, \mathbf{t}_m, r)$  index code for problem  $G = G_0 \circ (G_1, \dots, G_m)$ , a  $(k_1, \dots, k_m, r_0)$  index code for problem  $G_0$  can be constructed such that  $r_0 \leq r$ .



Let  $n_i = |V(G_i)|$  and  $\mathbf{t}_i = (t_{i1}, \dots, t_{in_i})$ . We denote a tuple of messages of problem  $G$  by  $(\mathbf{x}_1, \dots, \mathbf{x}_m)$ , where  $\mathbf{x}_i = (x_{i1}, \dots, x_{in_i})$  and  $x_{ij} \in \{0, 1\}^{t_{ij}}$  for  $i \in [m]$  and  $j \in [n_i]$ . Consider the one-to-one mapping

$$f_i : \{0, 1\}^{k_i} \rightarrow \{y_1, y_2, \dots, y_{2^{k_i}}\}, \quad i \in [m],$$

that maps the  $k_i$ -bit binary representation of  $j - 1$  to  $y_j$ ,  $j \in [2^{k_i}]$ .

Let  $\phi_G$  be the encoder of the  $(\mathbf{t}_1, \dots, \mathbf{t}_m, r)$  index code for problem  $G$ . For any message tuple  $(v_1, \dots, v_m)$ ,  $v_i \in \{0, 1\}^{k_i}$ , of problem  $G_0$  define

$$\phi_{G_0}(v_1, \dots, v_m) = \phi_G(f_1(v_1), \dots, f_m(v_m)). \quad (4.12)$$

The function  $\phi_{G_0}$  in (4.12) is the encoder of an index code for problem  $G_0$  iff any two message tuples to which the same codeword is assigned are nonconfusable. Hence, it suffices to show that if  $\phi_{G_0}(v_1, \dots, v_m) = \phi_{G_0}(v'_1, \dots, v'_m)$ , then  $(v_1, \dots, v_m)$  and  $(v'_1, \dots, v'_m)$  are nonconfusable for problem  $G_0$ . Suppose  $\phi_{G_0}(v_1, \dots, v_m) = \phi_{G_0}(v'_1, \dots, v'_m)$ . Then  $\phi_G(f_1(v_1), \dots, f_m(v_m)) = \phi_G(f_1(v'_1), \dots, f_m(v'_m))$ . By the definition of the mapping  $f_i$ , for every  $i \in [m]$ , either  $f_i(v_i) = f_i(v'_i)$  or  $f_i(v_i) \sim f_i(v'_i)$  in  $\Gamma_i$ . As  $\phi_G$  is the encoder of an index code for problem  $G$ ,  $(f_1(v_1), \dots, f_m(v_m))$  and  $(f_1(v'_1), \dots, f_m(v'_m))$  are nonconfusable for problem  $G$  and thus, if  $f_i(v_i) \sim f_i(v'_i)$  in  $\Gamma_i$ , then  $f_i(v_j) \neq f_i(v'_j)$  for some  $j \in A_i(G_0)$ . Hence, since  $f_i$  is one-to-one, for every  $i \in [m]$ , either  $v_i = v'_i$  or  $v_j \neq v'_j$  for some  $j \in A_i(G_0)$ . Therefore,  $(v_1, \dots, v_m)$  and  $(v'_1, \dots, v'_m)$  are nonconfusable for problem  $G_0$  and (4.12) defines the encoder of a  $(k_1, \dots, k_m, r_0)$  index code for problem  $G_0$  such that the set of codewords is a subset of the set of codewords of the  $(\mathbf{t}_1, \dots, \mathbf{t}_m, r)$  index code for problem  $G$ , which implies  $r_0 \leq r$ .

## 4.B Proof of Theorem 4.1

*Achievability:* Consider any rate tuple  $(\alpha_1 \mathbf{R}_1, \dots, \alpha_m \mathbf{R}_m)$ , where  $\mathbf{R}_i \in \mathcal{C}_i$ ,  $i \in [m]$ , and  $(\alpha_1, \dots, \alpha_m) \in \mathcal{C}_0$ . Let  $|V(G_i)| = n_i$ ,  $i \in [m]$ . Fix  $\epsilon > 0$ . By the definition of the capacity region, for each problem  $G_i$  there exists a  $(\mathbf{t}_i, r_i) = (t_{i1}, \dots, t_{in_i}, r_i)$  index code such that

$$\mathbf{R}_i \leq \frac{\mathbf{t}_i}{r_i} + \epsilon, \quad i \in [m], \quad (4.13)$$

and there exists a  $(\mathbf{t}_0, r_0) = (t_{01}, \dots, t_{0m}, r_0)$  index code for problem  $G_0$  such that

$$\alpha_i \leq \frac{t_{0i}}{r_0} + \epsilon, \quad i \in [m]. \quad (4.14)$$

We construct a code for problem  $G$  by concatenating the index codes for problems  $G_1, \dots, G_m$  and the index code for problem  $G_0$ . Let

$$\pi_i = \prod_{j \in [m]: j \neq i} r_j.$$

Consider the message tuple  $(\mathbf{x}_1, \dots, \mathbf{x}_m)$ , where  $\mathbf{x}_i \in (\prod_{j \in [n_i]} \{0, 1\}^{t_{ij}})^{\pi_i t_{0i}}$ ,  $i \in [m]$ . First, for each  $i \in [m]$ , the  $(\mathbf{t}_i, r_i)$  index code for problem  $G_i$  is applied  $\pi_i t_{0i}$  times to encode  $\mathbf{x}_i$  into  $y_i \in (\{0, 1\}^{r_i})^{\pi_i t_{0i}}$ . (Note that for each  $i \in [m]$ ,  $\pi_i r_i = \prod_{j \in [m]} r_j$ .) Next, the  $(\mathbf{t}_0, r_0)$  code for problem  $G_0$  is used  $\prod_{j \in [m]} r_j$  times to send  $(y_1, \dots, y_m) \in (\prod_{i \in [m]} \{0, 1\}^{t_{0i}})^{\prod_{j \in [m]} r_j}$ , which requires  $r_0 \prod_{j \in [m]} r_j$  transmissions. As for the decoding, first the decoder of the  $(\mathbf{t}_0, r_0)$  code for problem  $G_0$  is utilized to recover  $(y_1, \dots, y_m)$ . Then, for each  $i \in [m]$  decoder of the  $(\mathbf{t}_i, r_i)$  index code for problem  $G_i$  is used to recover the message tuple  $\mathbf{x}_i$  from  $y_i$ . Therefore, we

constructed a  $(\pi_1 t_{01} \mathbf{t}_1, \dots, \pi_m t_{0m} \mathbf{t}_m, r_0 \prod_{j \in [m]} r_j)$  code for problem  $G$  such that

$$\alpha_i \mathbf{R}_i \leq \left( \frac{t_{0i}}{r_0} + \epsilon \right) \left( \frac{\mathbf{t}_i}{r_i} + \epsilon \right) = \frac{\pi_i t_{0i} \mathbf{t}_i}{r_0 \prod_{j \in [m]} r_j} + \delta(\epsilon) \mathbf{1},$$

where  $\delta(\epsilon) \rightarrow 0$  as  $\epsilon \rightarrow \infty$ . Since for any  $\epsilon > 0$  the constructed code achieves  $(\alpha_1 \mathbf{R}_1 - \delta(\epsilon) \mathbf{1}, \dots, \alpha_m \mathbf{R}_m - \delta(\epsilon) \mathbf{1})$ , Letting  $\epsilon \rightarrow 0$  implies  $(\alpha_1 \mathbf{R}_1, \dots, \alpha_m \mathbf{R}_m) \in \mathcal{C}(G)$ .

*Converse:* Suppose  $(\mathbf{T}_1, \dots, \mathbf{T}_m) \in \mathcal{C}(G)$ . Then, by definition, for any  $\epsilon > 0$  there exists a  $(\mathbf{t}_1, \dots, \mathbf{t}_m, r)$  index code for problem  $G$  such that

$$\mathbf{T}_i \leq \frac{\mathbf{t}_i}{r} + \epsilon, \quad i \in [m]. \quad (4.15)$$

It suffices to show that  $\mathbf{t}_i/r$  can be written in the form of  $\alpha_i \mathbf{R}_i$ , where  $\mathbf{R}_i \in \mathcal{C}_i$  and  $(\alpha_1, \dots, \alpha_m) \in \mathcal{C}_0$ . For any  $\epsilon_0 > 0$ , there exists sufficiently large  $k$  such that

$$\frac{k \mathbf{t}_i}{\lfloor \log(\omega(\Gamma_{k \mathbf{t}_i}(G_i))) \rfloor} \leq \lim_{k \rightarrow \infty} \frac{k \mathbf{t}_i}{\log(\omega(\Gamma_{k \mathbf{t}_i}(G_i)))} + \epsilon_0, \quad i \in [m].$$

Let

$$\mathbf{R}_i = \frac{k \mathbf{t}_i}{\lfloor \log(\omega(\Gamma_{k \mathbf{t}_i}(G_i))) \rfloor} - \epsilon_0 \mathbf{1}, \quad i \in [m].$$

By Theorem 3.2,  $\mathbf{R}_i \in \mathcal{C}_i$ ,  $i \in [m]$ . Also consider the  $(k \mathbf{t}_1, \dots, k \mathbf{t}_m)$  code for problem  $G$  constructed by repeating the  $(\mathbf{t}_1, \dots, \mathbf{t}_m, r)$  code (the very same code satisfying (4.15))  $k$  times and let

$$\alpha_i = \frac{\lfloor \log(\omega(\Gamma_{k \mathbf{t}_i}(G_i))) \rfloor}{kr}, \quad i \in [m].$$

By Lemma 4.1,  $(\alpha_1, \dots, \alpha_m) \in \mathcal{C}_0$ . Therefore, we have

$$\mathbf{T}_i \leq \frac{\mathbf{t}_i}{r} + \epsilon = \frac{k\mathbf{t}_i}{kr} + \epsilon = \alpha_i(\mathbf{R}_i + \epsilon_0 \mathbf{1}) + \epsilon,$$

where  $\mathbf{R}_i \in \mathcal{C}_i$ ,  $i \in [m]$ , and  $(\alpha_1, \dots, \alpha_m) \in \mathcal{C}_0$ . The desired result follows by letting  $\epsilon \rightarrow 0$  and  $\epsilon_0 \rightarrow 0$ , and using Remark 4.3.

# Chapter 5

## Performance Limits

We discuss several lower bounds on the broadcast rate and outer bounds on the capacity region.

### 5.1 Maximum Acyclic Induced Subgraph (MAIS) Bound

The simplest lower bound on the broadcast rate is a direct corollary of the structural properties established in the previous section. First note that the broadcast rate of any index coding problem  $G$  is lower bounded by the broadcast rate of any vertex induced subgraph  $G_0$  of  $G$ . This fact together with Proposition 4.1, implies that for any *acyclic* vertex induced subgraph  $G_0$  of index coding problem  $G$ , we have  $|V(G_0)| = \beta(G_0) \leq \beta(G)$ . Considering all (maximal) acyclic subgraphs of  $G$ , we establish the following lower bound on the broadcast rate [25].

**Proposition 5.1** (Maximal acyclic induced subgraph (MAIS) bound). *Any achievable rate tuple for index coding problem  $G$  must belong to the outer bound  $\mathcal{R}_{\text{MAIS}}$*

on the capacity region that consists of all rate tuples  $(R_1, \dots, R_n)$  satisfying

$$\sum_{i \in J} R_i \leq 1 \tag{5.1}$$

for all  $J$  such that  $G|_J$  is acyclic.

**Remark 5.1.** For any index coding problem  $G$ , the maximum acyclic induced subgraph (MAIS) lower bound on the broadcast rate is

$$\beta_{\text{MAIS}}(G) := \max_{J \subseteq V(G): G|_J \text{ is acyclic}} |J| \leq \beta(G).$$

**Remark 5.2.** Since every independent set is acyclic, the MAIS bound in Remark 5.1 can be relaxed as  $\alpha(G) \leq \beta(G)$ .

Application of the MAIS bound is illustrated by the following.

**Example 5.1.** In the side information graph  $G$  as shown in Figure 5.1, the subgraphs  $G|_{\{1\}}$  and  $G|_{\{2,3\}}$  are acyclic and thus  $\beta(G) \geq \beta_{\text{MAIS}}(G) = 2$  and  $\mathcal{C}(G) \subseteq \mathcal{R}_{\text{MAIS}}(G)$ , where  $\mathcal{R}_{\text{MAIS}}(G)$  consists of all rate tuples  $(R_1, R_2, R_3)$  such that

$$\begin{aligned} R_1 &\leq 1, \\ R_2 + R_3 &\leq 1. \end{aligned}$$

Similar to the broadcast rate, the MAIS bound is multiplicative under the lexicographic product of side information graphs. The proof is relegated to Appendix 5.A.

**Proposition 5.2.** For any two side information graphs  $G_0$  and  $G_1$ ,  $\beta_{\text{MAIS}}(G_0 \circ G_1) = \beta_{\text{MAIS}}(G_0)\beta_{\text{MAIS}}(G_1)$ .

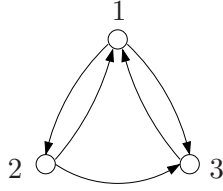

**Figure 5.1:** An index coding instance with three messages.

The MAIS bound is not tight in general (see Example 5.2). Using Corollary 4.2 and Proposition 5.2, we can show that the gap between the MAIS bound and the broadcast rate of the index coding problem can be magnified to a multiplicative factor that grows polynomially in the number of messages of the problem.

**Proposition 5.3.** *Let  $G$  be the side information graph of an index coding problem with  $n$  messages for which  $\beta(G)/\beta_{\text{MAIS}}(G) = \rho > 1$ . Then*

$$\frac{\beta(G^{\circ k})}{\beta_{\text{MAIS}}(G^{\circ k})} = \frac{\beta(G)^k}{\beta_{\text{MAIS}}(G)^k} = \rho^k = N^{\log_n(\rho)},$$

where  $N = n^k$  is the number of vertices of  $G^{\circ k}$ .

## 5.2 Polymatroidal Bound

Let  $(R_1, \dots, R_n)$  be an achievable rate tuple for the index coding instance  $(i|A_i)$ ,  $i \in [n]$ . Then, there exists a  $(t_1, \dots, t_n, r)$  index code with encoding function  $\phi$  and decoding functions  $\psi_i$ ,  $i \in [n]$ , such that

$$R_i \leq \frac{t_i}{r}.$$

Let  $X_i$  be the uniform random variable over  $\{0, 1\}^{t_i}$  representing message  $i \in [n]$ .  
Therefore,

$$H(X_i) = t_i, \quad i \in [n]. \quad (5.2)$$

Moreover, by the independence of the random variables  $X_1, \dots, X_n$ ,

$$H(X_1, \dots, X_n) = \sum_{i \in [n]} H(X_i). \quad (5.3)$$

Let  $Y = \phi(X_1, \dots, X_n)$  be the random variable over  $\{0, 1\}^r$  representing the encoder output. Then

$$H(Y) \leq r \quad (5.4)$$

and

$$H(Y | X_1, \dots, X_n) = 0. \quad (5.5)$$

Since receiver  $i$  can recover its desired message based on the received codeword and its side information, we also have the following decodability conditions

$$H(X_i | Y, X(A_i)) = 0, \quad i \in [n]. \quad (5.6)$$



Now consider

$$\begin{aligned}
R_i &\leq \frac{t_i}{r} \\
&= \frac{1}{r} H(X_i) \\
&= \frac{1}{r} (H(X_i) - H(X_i|Y, X(A_i))) \tag{5.7}
\end{aligned}$$

$$= \frac{1}{r} (H(X_i|X(A_i)) - H(X_i|Y, X(A_i))) \tag{5.8}$$

$$= \frac{1}{r} I(X_i; Y | X(A_i))$$

$$= \frac{1}{r} (H(Y|X(A_i)) - H(Y|X_i, X(A_i)))$$

$$\leq \frac{1}{H(Y)} (H(Y|X(A_i)) - H(Y|X_i, X(A_i))). \tag{5.9}$$

Define a set function  $f : 2^{[n]} \rightarrow [0, 1]$  as

$$f(J) = \frac{1}{H(Y)} H(Y|X(\bar{J})), \quad J \subseteq [n]. \tag{5.10}$$

Then (5.9) can be rewritten as

$$R_i \leq f(B_i \cup \{i\}) - f(B_i), \quad i \in [n].$$

In the following we investigate some properties of the set function  $f$  defined in (5.10). First,

$$f(\emptyset) = \frac{1}{H(Y)} H(Y|X([n])) = 0 \tag{5.11}$$

and

$$f([n]) = \frac{1}{H(Y)} H(Y) = 1. \tag{5.12}$$

Second, since conditioning reduces entropy,

$$f(J) = H(Y|X(\bar{J})) \leq H(Y|X(\bar{K})) = f(K), \quad J \subseteq K. \quad (5.13)$$

Finally,

$$\begin{aligned} & H(Y)(f(J \cup K) - f(J)) \\ &= H(Y|X(\bar{J} \cap \bar{K})) - H(Y|X(\bar{J})) \\ &= I(Y; X(\bar{J} \setminus \bar{K})|X(\bar{J} \cap \bar{K})) \\ &= H(X(\bar{J} \setminus \bar{K})|X(\bar{J} \cap \bar{K})) - H(X(\bar{J} \setminus \bar{K})|Y, X(\bar{J} \cap \bar{K})) \\ &= H(X(\bar{J} \setminus \bar{K})|X(\bar{K})) - H(X(\bar{J} \setminus \bar{K})|Y, X(\bar{J} \cap \bar{K})) \\ &\leq H(X(\bar{J} \setminus \bar{K})|X(\bar{K})) - H(X(\bar{J} \setminus \bar{K})|Y, X(\bar{K})) \\ &= I(Y; X(\bar{J} \setminus \bar{K})|X(\bar{K})) \\ &= H(Y|X(\bar{K})) - H(Y|X(\bar{J} \cup \bar{K})) \\ &= H(Y)(f(K) - f(J \cap K)), \end{aligned} \quad (5.14)$$

which shows that  $f$  is also submodular. In summary, if  $(R_1, \dots, R_n)$  is achievable,  $R_i \leq f(B_i \cup \{i\}) - f(B_i)$ ,  $i \in [n]$ , for some submodular nondecreasing set function  $f$  satisfying (5.11)–(5.14). This yields an outer bound on the capacity region (a lower bound on the broadcast rate) referred to as the polymatroidal bound. This bound has been introduced in [35], [36], and [37] in the context of distributed source coding, network coding, and index coding, respectively.

**Theorem 5.1** (Polymatroidal bound). *Any achievable rate tuple for index coding problem  $G$  must belong to the outer bound  $\mathcal{B}_{\text{PM}}$  on the capacity region that consists*

of all rate tuples  $(R_1, \dots, R_n)$  satisfying

$$R_i \leq f(B_i \cup \{i\}) - f(B_i), \quad i \in [n], \quad (5.15)$$

for some set function  $f : 2^{[n]} \rightarrow [0, 1]$  such that

$$f(\emptyset) = 0, \quad (5.16)$$

$$f([n]) = 1, \quad (5.17)$$

$$f(J) \leq f(K), \quad J \subseteq K, \quad (5.18)$$

$$f(J \cap K) + f(J \cup K) \leq f(J) + f(K). \quad (5.19)$$

**Remark 5.3.** Given an index coding instance, the polymatroidal bound  $\mathcal{R}_{\text{PM}}$  is computed by eliminating the  $f$  variables from (5.16)–(5.15) through Fourier–Motzkin elimination [57, Appendix D].

**Remark 5.4.** For any index coding problem  $G$

$$\beta_{\text{PM}}(G) := \max_{i \in [n]} \frac{1}{f(B_i \cup \{i\}) - f(B_i)} \leq \beta(G),$$

for some set function  $f$  satisfying (5.16)–(5.19).

**Remark 5.5.** The quantity  $1/\beta_{\text{PM}}(G)$  is the solution to the following linear program with  $2^n + 1$  variables.

$$\begin{aligned} & \text{maximize } R \\ & \text{subject to } R \leq f(B_i \cup \{i\}) - f(B_i), \quad i \in [n], \\ & \quad f \text{ satisfies (5.16) – (5.19).} \end{aligned}$$

The number of constraints that the set function  $f$  in Theorem 5.1 needs to

satisfy is  $O(2^{2n})$ . The following can reduce the number of constraints to  $O(n^2 2^n)$ , the proof of which is relegated to Appendix 5.B.

**Lemma 5.1.** *The properties (5.16)–(5.19) of the set function  $f$  in the polymatroidal bound can be simplified to the following:*

$$f(\emptyset) = 0, \tag{5.20}$$

$$f([n]) = 1, \tag{5.21}$$

$$f(J) \leq f([n]), \quad |J| = n - 1, \tag{5.22}$$

$$f(J \cap K) + f(J \cup K) \leq f(J) + f(K), \quad |J \setminus K| = |K \setminus J| = 1. \tag{5.23}$$

The polymatroidal bound contains the MAIS bound as a special case.

**Proposition 5.4.** *For any index coding problem  $G$ ,  $\mathcal{R}_{\text{PM}}(G) \subseteq \mathcal{R}_{\text{MAIS}}(G)$  and consequently  $\beta_{\text{MAIS}}(G) \leq \beta_{\text{PM}}(G)$ .*

The proof of the proposition is presented in Appendix 5.C. The inclusion in Proposition 5.4 can be strict as illustrated by the following.

**Example 5.2.** For the index coding problem  $G$  shown in Figure 5.2 we have  $\beta_{\text{MAIS}}(G) = 2$  and the MAIS outer bound is characterized by

$$\begin{aligned} R_1 + R_3 &\leq 1, \\ R_1 + R_4 &\leq 1, \\ R_2 + R_4 &\leq 1, \\ R_2 + R_5 &\leq 1, \\ R_3 + R_5 &\leq 1. \end{aligned} \tag{5.24}$$

However, it can be shown that the polymatroidal bound yields the tighter bound

$\beta_{\text{PM}}(G) = 2.5$  on the broadcast rate and the polymatroidal outer bound  $\mathcal{B}_{\text{PM}}(G)$  is characterized by the inequalities in (5.24) and

$$R_1 + R_2 + R_3 + R_4 + R_5 \leq 2. \quad (5.25)$$

In Section 6, we will see that for this example the polymatroidal bound is tight, i.e.,  $\beta(G) = 2.5$  and the capacity region  $\mathcal{C}(G)$  is characterized by (5.24) and (5.25).

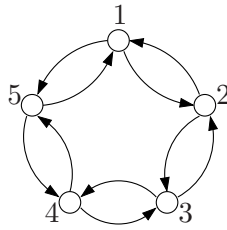

**Figure 5.2:** A 5-node index coding problem

Blasiak, Kleinberg, and Lubetzky [37] showed that the polymatroidal bound satisfies the following structural property.

**Proposition 5.5** ([37]). *For any two graphs  $G_0$  and  $G_1$ ,*

$$\beta_{\text{PM}}(G_0 \circ G_1) \geq \beta_{\text{PM}}(G_0)\beta_{\text{PM}}(G_1). \quad (5.26)$$

Example 5.2 shows that there is a gap between the polymatroidal bound and the MAIS bound. Using Proposition 5.2 and Proposition 5.5, the gap between the MAIS bound and the polymatroidal bound of the index coding problem can be magnified to a multiplicative factor that grows polynomially in the number of messages of the problem.

**Proposition 5.6** ([37]). *Let  $G$  be an  $n$ -node graph such that  $\beta_{\text{PM}}(G)/\beta_{\text{MAIS}}(G) =$*

$\rho > 1$ . Then

$$\frac{\beta_{\text{PM}}(G^{\circ k})}{\beta_{\text{MAIS}}(G^{\circ k})} \geq \frac{\beta_{\text{PM}}(G)^k}{\beta_{\text{MAIS}}(G)^k} = \rho^k = N^{\log_n(\rho)},$$

where  $N = n^k$  is the number of vertices of  $G^{\circ k}$ .

**Open problem 5.1.** Does the inequality in Proposition 5.5 hold with equality?

### 5.3 Information Inequalities and Lower Bounds

For any joint distribution for the collection of  $n$  random variables  $X_1, \dots, X_n$ ,  $(2^n - 1)$  joint entropies  $H(X(J))$ ,  $J \subseteq [n]$ , satisfy

$$H(X(J, K, L)) - H(X(K, L)) \leq H(X(J, K)) - H(X(K)), \quad (5.27)$$

or equivalently

$$I(X(J); X(L) | X(K)) \geq 0. \quad (5.28)$$

Any convex combination of these linear inequalities is a valid linear inequality on  $H(X(J))$ ,  $J \subseteq [n]$ , and is referred to as a *Shannon-type* inequality. Surprisingly, there are some linear inequalities on  $H(X(J))$ ,  $J \subseteq [n]$ , that cannot be written as such convex combinations. These inequalities are referred to as *non-Shannon-type* inequalities, including the following example discovered by Zhang and Yeung [58].

$$\begin{aligned} & 3H(X_1, X_3) + 3H(X_1, X_4) + 3H(X_3, X_4) + H(X_2, X_3) + H(X_2, X_4) \\ & \geq 2H(X_3) + 2H(X_4) + H(X_1, X_2) + H(X_1) \\ & \quad + H(X_2, X_3, X_4) + 4H(X_1, X_3, X_4) \end{aligned} \quad (5.29)$$

Matus [59] showed that even for only four random variables, there are infinitely many independent non-Shannon-type information inequalities.

Let  $(R_1, \dots, R_n)$  be an achievable rate tuple for the index coding instance  $(i|A_i), i \in [n]$ . Then, there exists a  $(t_1, \dots, t_n, r)$  index code with encoding function  $\phi$  and decoding functions  $\psi_i, i \in [n]$ , such that

$$R_i \leq \frac{t_i}{r}. \quad (5.30)$$

A given  $(t_1, \dots, t_n, r)$  index code induces  $n + 1$  random variables  $X_1, \dots, X_n$ , and  $X_0$ , where  $X_i, i \in [n]$ , is the uniform random variable over  $\{0, 1\}^{t_i}$  representing the  $i$ th message and  $X_0$  is the random variable over  $\{0, 1\}^r$  that represents the output of the encoding function. One can form an outer bound on the capacity region (a lower bound on the broadcast rate) of the index coding problem by considering all linear inequalities that hold for joint entropies of any tuple of  $n + 1$  random variables. However, as there are infinitely many such inequalities, we instead consider all Shannon-type inequalities.

Define a set function  $h : 2^{\{0\} \cup [n]} \rightarrow \mathbb{R}_+$  as

$$h(J) = H(X(J)), \quad J \subseteq \{0\} \cup [n]. \quad (5.31)$$

Noting that  $H(X_i) = t_i, i \in [n]$ , and  $H(X_0) \leq r$ , we can rewrite (5.30) as

$$R_i \leq \frac{h(\{i\})}{h(\{0\})}, \quad i \in [n].$$

Moreover, by the independence of the random variables  $X_1, \dots, X_n$ ,

$$h([n]) = H(X_1, \dots, X_n) = \sum_{i \in [n]} H(X_i) = \sum_{i \in [n]} h(\{i\}). \quad (5.32)$$

Since  $X_0 = \phi(X_1, \dots, X_n)$ , we have  $H(X_0|X_1, \dots, X_n) = 0$  which implies

$$h(\{0\} \cup [n]) = h([n]). \quad (5.33)$$

By the decodability assumption at each receiver  $i \in [n]$ , we have  $H(X_i|Y, X(A_i)) = 0$  which implies

$$h(\{i\} \cup A_i \cup \{0\}) = h(A_i \cup \{0\}), \quad i \in [n]. \quad (5.34)$$

Finally, rewriting inequality (5.27) in terms of the set function  $h$ , we get

$$h(K) + h(J \cup K \cup L) \leq h(J \cup K) + h(K \cup L). \quad (5.35)$$

This yields the following outer bound on the capacity region (lower bound on the broadcast rate).

**Theorem 5.2.** *Any achievable rate tuple for index coding problem  $G$  must belong to the outer bound  $\mathcal{R}_{\text{Sh}}$  on the capacity region that consists of all rate tuples  $(R_1, \dots, R_n)$  satisfying*

$$R_i \leq \frac{h(\{i\})}{h(\{0\})}, \quad i \in [n],$$



for some set function  $h : 2^{\{0\} \cup [n]} \rightarrow \mathbb{R}_+$  such that

$$h(\emptyset) = 0, \quad (5.36)$$

$$h([n]) = \sum_{i \in [n]} h(\{i\}), \quad (5.37)$$

$$h(\{0\} \cup [n]) = h([n]), \quad (5.38)$$

$$h(\{i\} \cup A_i \cup \{0\}) = h(A_i \cup \{0\}), \quad i \in [n], \quad (5.39)$$

$$h(K) + h(J \cup K \cup L) \leq h(J \cup K) + h(K \cup L), \quad J, K, L \subseteq \{0\} \cup [n]. \quad (5.40)$$

**Remark 5.6.** Since the joint entropies  $H(J)$ ,  $J \subseteq [n]$ , satisfy a finite number of inequalities, the resulting bound  $\mathcal{R}_{\text{Sh}}$  on the rates can be computed by Fourier–Motzkin elimination [57, 7, Appendix D].

**Remark 5.7.** For any index coding problem  $G$

$$\beta_{\text{Sh}}(G) := h(\{0\}) \max_{i \in [n]} \frac{1}{h(\{i\})} \leq \beta(G),$$

for some set function  $h$  satisfying Equations (5.36)–(5.40). The quantity  $1/\beta_{\text{Sh}}(G)$  is the solution to the corresponding linear program involving  $2^{n+1} + 1$  variables.

In the polymatroidal outer bound  $\mathcal{R}_{\text{PM}}$ , established earlier in Remark 5.4, we did not explicitly use all Shannon inequalities. Nonetheless,  $\mathcal{R}_{\text{PM}}$  is as tight as the apparently stronger bound  $\mathcal{R}_{\text{Sh}}$ , as will be shown in Appendix 5.D.

**Proposition 5.7.**  $\mathcal{R}_{\text{Sh}} = \mathcal{R}_{\text{PM}}$ .

The polymatroidal bound (which effectively uses all Shannon-type inequalities) is not tight in general and can be improved by considering non-Shannon-type inequalities, as illustrated by the following examples.

**Example 5.3.** Sun and Jafar [33] showed that for index coding problem

$$\begin{aligned}
 &(1|2, 3, 6, 7, 8, 9, 10, 11), \\
 &(2|1, 3, 4, 6, 7, 8, 9, 10, 11), \\
 &(3|1, 2, 4, 5, 6, 7, 8, 9, 10, 11), \\
 &(4|1, 2, 3, 5, 6, 7, 8, 9, 10, 11), \\
 &(5|1, 3, 4, 6, 7, 8, 9, 10, 11), \\
 &(6|1, 4, 5, 7, 8, 9, 10, 11), \\
 &(7|2, 4, 5, 6, 8, 9, 10, 11), \\
 &(8|1, 3, 5, 6, 7, 9, 10, 11), \\
 &(9|1, 2, 5, 6, 7, 8, 10, 11), \\
 &(10|1, 2, 4, 6, 7, 8, 9, 11), \\
 &(11|1, 2, 3, 5, 7, 8, 9, 10),
 \end{aligned}$$

$\beta_{\text{PM}} = 2.5$ , whereas using the Zhang-Yeung non-Shannon-type information inequality (see (5.29)) yields a tighter outer bound of  $28/11 = 2.5454$ .

**Example 5.4.** Baber, Christofides, Dang, Riis, and Vaughan [38] showed that for

the index coding problem

$$\begin{aligned}
 &(1|2, 3, 4, 5, 6, 7), \\
 &(2|1, 3, 7, 9, 10), \\
 &(3|1, 2, 4, 8, 9), \\
 &(4|1, 3, 5, 8, 10), \\
 &(5|1, 4, 6, 9, 10), \\
 &(6|1, 5, 7, 8, 9), \\
 &(7|1, 2, 6, 8, 10), \\
 &(8|3, 4, 6, 7, 9, 10), \\
 &(9|2, 3, 5, 6, 8), \\
 &(10|2, 4, 5, 7, 8).
 \end{aligned}$$

which has an undirected side information graph, the polymatroidal bound is  $\beta_{\text{PM}} = 56/17 = 3.2941$ , whereas using the Zhang-Yeung non-Shannon-type information inequality yields the lower bound of  $598/181 = 3.3038$  and using the 214 non-Shannon-type information inequalities given by Dougherty, Freiling, and Zeger [60] yields the even tighter lower bound of  $29523/8929 = 3.3064$  on the broadcast rate. Note that in [38] this example is discussed in the context of guessing games [14], which is converted to the corresponding index coding instance (see Section 10 for the exact relationship between index coding and guessing games).

It still remains open to determine whether the polymatroidal bound is within a constant factor from the broadcast rate or there exists a polynomially large multiplicative gap between them. If the inequality in (5.26) holds with equality (see Open problem 5.1), then similar to Proposition 5.3, the gap between the

broadcast rate and the polymatroidal bound (or equivalently, the gap between Shannon-type and non-Shannon-type inequalities) can be magnified to a multiplicative factor that grows polynomially in the number of messages.

Chapter 5, in full, is a reprint of the material in the papers: Fatemeh Arbabjolfaei, Bernd Bandemer, Young-Han Kim, Eren Sasoglu, Lele Wang, “On the capacity region for index coding”, *Proceedings of the IEEE International Symposium on Information Theory*, Istanbul, Turkey, July 2013; and Fatemeh Arbabjolfaei and Young-Han Kim, “Elements of index coding”, to be submitted to *Foundations and Trends in Communications and Information Theory*. The dissertation author was the primary investigator and author of these papers.

## 5.A Proof of Proposition 5.2

Let  $G = G_0 \circ G_1$ .

*Proof of “ $\geq$ ”.* Suppose  $S_0$  and  $S_1$  induce maximum acyclic subgraphs of  $G_0$  and  $G_1$ , respectively, i.e.,  $\beta_{\text{MAIS}}(G_0) = |S_0|$  and  $\beta_{\text{MAIS}}(G_1) = |S_1|$ . Thus,  $S_0 \times S_1$  induces an acyclic subgraph of  $G$ , which implies  $\beta_{\text{MAIS}}(G) \geq \beta_{\text{MAIS}}(G_0)\beta_{\text{MAIS}}(G_1)$ .

*Proof of “ $\leq$ ”.* Let  $S^* \subseteq V(G_0) \times V(G_1)$  be a maximum set such that  $G|_{S^*}$  is acyclic, i.e.,  $\beta_{\text{MAIS}}(G) = |S^*|$ . WLOG assume  $V(G_0) = [m]$ . Then,  $S^*$  can be partitioned as  $S^* = S_1 \cup \dots \cup S_m$ , where  $S_i$  induces an acyclic subgraph of  $G_1$  and thus,

$$|S_i| \leq \beta_{\text{MAIS}}(G_1), \quad i \in [m]. \quad (5.41)$$

Define  $I = \{i: S_i \neq \emptyset\}$ . Since  $G|_{S^*}$  is acyclic,  $I$  induces an acyclic subgraph of  $G_0$  and thus,

$$|I| \leq \beta_{\text{MAIS}}(G_0). \quad (5.42)$$

Hence, we have

$$\begin{aligned}\beta_{\text{MAIS}}(G) &= \sum_{i \in I} |S_i| \\ &\leq \sum_{i \in I} \beta_{\text{MAIS}}(G_1)\end{aligned}\tag{5.43}$$

$$\leq \beta_{\text{MAIS}}(G_0)\beta_{\text{MAIS}}(G_1).\tag{5.44}$$

where (5.43) follows by (5.41) and (5.44) follows by (5.42).

## 5.B Proof of Lemma 5.1

Clearly, (5.20)–(5.23) follow by (5.16)–(5.19). Hence, it suffices to show that (5.16)–(5.19) can be deduced from (5.20)–(5.23). Assume (5.20)–(5.23) hold.

Proof of (5.19): Assume that  $|J \setminus K| = M$  and  $|K \setminus J| = N$ . Note that if  $J \subseteq K$  we get a trivial inequality. So without loss of generality we can assume that  $1 \leq M \leq N$ . We use induction on  $N + M$ . As for the induction base we have if  $N + M = 2$ , then  $M = N = 1$  and (5.19) holds. Let  $k \geq 3$  and assume that (5.19) holds for  $N + M \leq k - 1$ . If  $N + M = k$ , then  $|K \setminus J| \geq 2$  and thus there exists two distinct elements  $a, b \in K \setminus J$ . Considering  $J$  and  $K \setminus \{b\}$ , by the induction hypothesis, we have

$$f(J \cap K) + f(J \cup (K \setminus \{b\})) \leq f(J) + f(K \setminus \{b\}).\tag{5.45}$$

Next, consider  $J \cup (K \setminus \{b\})$  and  $K$ . We have  $(J \cup (K \setminus \{b\})) \cup K = J \cup K$  and  $(J \cup (K \setminus \{b\})) \cap K = K \setminus \{b\}$ . Therefore, by the induction hypothesis,

$$f(K \setminus \{b\}) + f(J \cup K) \leq f(J \cup (K \setminus \{b\})) + f(K). \quad (5.46)$$

(5.19) follows by (5.45) and (5.46).

Proof of (5.18): We first use reverse induction on  $|K|$  to show

$$\text{if } J \subseteq K \text{ and } |J| = |K| - 1, \text{ then } f(J) \leq f(K). \quad (5.47)$$

As for the induction base we have if  $|K| = n$ , (5.47) follows by (5.22). Let  $N < n$  and assume that (5.47) holds for all  $|K| \geq N + 1$ . Hence, there exists  $a \in [n] \setminus K$ . Considering  $J \cup \{a\}$  and  $K$ , by (5.19), we have

$$f(J) + f(K \cup \{a\}) \leq f(J \cup \{a\}) + f(K). \quad (5.48)$$

By the induction hypothesis,

$$f(J \cup \{a\}) \leq f(K \cup \{a\}). \quad (5.49)$$

Summing up (5.48) and (5.49) yields  $f(J) \leq f(K)$ . (5.18) follows by using (5.47) multiple times.

## 5.C Proof of Proposition 5.4

We show that every inequality of the MAIS bound can be derived using the inequalities of the polymatroidal bound, i.e, (5.16)–(5.15). By submodularity of

set function  $f$  (see (5.19)) we have

$$f(\{i\} \cup K) - f(K) \leq f(\{i\} \cup J) - f(J), \quad J \subseteq K \subseteq [n], \quad (5.50)$$

for any  $i \in \bar{K}$ . Suppose  $J \subseteq V(G)$  induces an acyclic subgraph of  $G$ . Then, there exists a permutation  $\pi : J \rightarrow J$  such that if  $\pi(i) < \pi(j)$ , then  $j \in B_i$ . Let  $J_i = \{j \in J : \pi(i) < \pi(j)\}$ . Note that by the definition of  $\pi$ ,  $J_i \subseteq B_i$ . We have

$$\sum_{i \in J} R_i \leq \sum_{i \in J} (f(\{i\} \cup B_i) - f(B_i)) \quad (5.51)$$

$$\leq \sum_{i \in J} (f(\{i\} \cup J_i) - f(J_i)) \quad (5.52)$$

$$\leq f(\{\pi^{-1}(1)\} \cup J_{\pi^{-1}(1)}) - f(J_{\pi^{-1}(1)}) \quad (5.53)$$

$$\leq 1, \quad (5.54)$$

where (5.51) follows by (5.15), (5.52) follows by (5.50), and (5.53) holds since if  $\pi(i) < \pi(j)$ , then  $(\{j\} \cup J_j) \subseteq J_i$  and thus, by (5.19),  $f(J_i) - f(\{j\} \cup J_j) \leq 0$ . (5.54) follows by (5.16), since  $J_{\pi^{-1}(1)} = \emptyset$ . This completes the proof of the proposition.

## 5.D Proof of Proposition 5.7

We first show that  $\mathcal{R}_{\text{Sh}} \subseteq \mathcal{R}_{\text{PM}}$ . Suppose  $(R_1, \dots, R_n) \in \mathcal{R}_{\text{Sh}}$ . Then there exists  $h(J)$ ,  $J \subseteq \{0\} \cup [n]$ , satisfying (5.36)–(5.40) such that

$$R_i \leq \frac{h(\{i\})}{h(\{0\})}, \quad i \in [n]. \quad (5.55)$$

For  $A, B \subseteq \{0\} \cup [n]$ , let  $J = A \setminus B$ ,  $K = A \cap B$ , and  $L = B \setminus A$ . Then (5.40) implies that the set function  $h$  is submodular:

$$h(A \cap B) + h(A \cup B) \leq h(A) + h(B). \quad (5.56)$$

Let  $K = \emptyset$ . Then, by (5.36) and (5.40),

$$h(J \cup L) \leq h(J) + h(L). \quad (5.57)$$

Now consider

$$h([n]) \leq h(J) + h(\bar{J}) \quad (5.58)$$

$$\leq \sum_{i \in J} h(\{i\}) + \sum_{i \in \bar{J}} h(\{i\}) \quad (5.59)$$

$$= \sum_{i \in [n]} h(\{i\}), \quad (5.60)$$

where (5.58) and (5.59) follow by (5.57). Comparing (5.60) and (5.37) implies

$$h(J) = \sum_{i \in J} h(\{i\}), \quad J \subseteq [n]. \quad (5.61)$$

Define a set function  $f : 2^{[n]} \rightarrow [0, 1]$  as

$$f(J) = \frac{h(\bar{J} \cup \{0\}) - h(\bar{J})}{h(\{0\})}. \quad (5.62)$$



Then (5.55) can be rewritten as

$$\begin{aligned} R_i &\leq \frac{h(\{i\})}{h(\{0\})} \\ &= \frac{1}{h(\{0\})}(-h(A_i) + h(\{i\} \cup A_i)) \end{aligned} \quad (5.63)$$

$$= \frac{1}{h(\{0\})}(h(A_i \cup \{0\}) - h(A_i) - (h(A_i \cup \{0\}) - h(\{i\} \cup A_i))) \quad (5.64)$$

$$= \frac{1}{h(\{0\})}(h(A_i \cup \{0\}) - h(A_i) - (h(\{i\} \cup A_i \cup \{0\}) - h(\{i\} \cup A_i))) \quad (5.65)$$

$$= f(\{i\} \cup B_i) - f(B_i), \quad (5.66)$$

where (5.63) follows by (5.61), (5.65) follows by (5.39), and (5.66) follows by the definition of function  $f$  in (5.62). We now show that the set function  $f$  defined in (5.62) satisfies (5.16)–(5.19). First, by (5.38),

$$f(\emptyset) = \frac{h([n] \cup \{0\}) - h([n])}{h(\{0\})} = 0$$

and

$$f([n]) = \frac{h(\{0\})}{h(\{0\})} = 1.$$

Let  $J \subseteq K \subseteq [n]$ . Then we have

$$\begin{aligned} f(J) &= \frac{1}{h(\{0\})}(h(\bar{J} \cup \{0\}) - h(\bar{J})) \\ &= \frac{1}{h(\{0\})}(h(\bar{K} \cup (K \setminus J) \cup \{0\}) - h(\bar{K}) - h(K \setminus J)) \end{aligned} \quad (5.67)$$

$$\leq \frac{1}{h(\{0\})}(h(\bar{K} \cup \{0\}) + h(K \setminus J) - h(\bar{K}) - h(K \setminus J)) \quad (5.68)$$

$$= \frac{1}{h(\{0\})}(h(\bar{K} \cup \{0\}) - h(\bar{K})) \quad (5.69)$$

$$= f(K), \quad (5.70)$$

where (5.67) follows by (5.61) since  $\bar{J} = \bar{K} \cup (K \setminus J)$ , and (5.68) follows by submodularity of the set function  $g$  in (5.56). Finally, for any  $J, K \subseteq [n]$  we have

$$\begin{aligned} &h(\{0\})(f(J \cup K) + f(J \cap K)) \\ &= h((\bar{J} \cap \bar{K}) \cup \{0\}) - h(\bar{J} \cap \bar{K}) + h(\bar{J} \cup \bar{K} \cup \{0\}) - h(\bar{J} \cup \bar{K}) \\ &= h((\bar{J} \cup \{0\}) \cap (\bar{K} \cup \{0\}) - h(\bar{J} \cap \bar{K})) + h(\bar{J} \cup \bar{K} \cup \{0\}) - h(\bar{J} \cup \bar{K}) \\ &\leq h(\bar{J} \cup \{0\}) - h(\bar{J} \cap \bar{K}) + h(\bar{K} \cup \{0\}) - h(\bar{J} \cup \bar{K}) \end{aligned} \quad (5.71)$$

$$= h(\bar{J} \cup \{0\}) - h(\bar{J} \cap \bar{K}) + h(\bar{K} \cup \{0\}) - h(\bar{J}) - h(\bar{K} \setminus \bar{J}) \quad (5.72)$$

$$= h(\bar{J} \cup \{0\}) - h(\bar{J} \cap \bar{K}) + h(\bar{K} \cup \{0\}) - h(\bar{J}) - h(\bar{K} \cap J) \quad (5.73)$$

$$= h(\bar{J} \cup \{0\}) - h(\bar{J}) + h(\bar{K} \cup \{0\}) - h(\bar{K}) \quad (5.74)$$

$$= h(\{0\})(f(J) + f(K)), \quad (5.75)$$

where (5.71) follows by (5.56), and (5.72) and (5.74) follow by (5.61).

Next, we show  $\mathcal{R}_{\text{PM}} \subseteq \mathcal{R}_{\text{Sh}}$ . Assume  $(R_1, \dots, R_n) \in \mathcal{R}_{\text{PM}}$ . Then there exists a set function  $f$  satisfying (5.16)–(5.19). Define a set function  $h : 2^{\{0\} \cup [n]} \rightarrow \mathbb{R}_+$  as

follows. For  $J \subseteq [n]$ ,

$$h(J) = \sum_{i \in J} (f(\{i\} \cup B_i) - f(B_i)) \quad (5.76)$$

and

$$h(J \cup \{0\}) = h(J) + f(\bar{J}). \quad (5.77)$$

Property (5.36) follows by the definition of the set function  $h$  in (5.76). Hence, by (5.77) and (5.17),  $h(\{0\}) = 1$  and thus,

$$R_i \leq \frac{h(\{i\})}{h(\{0\})}, \quad i \in [n].$$

Property (5.37) follows by the definition of the set function  $h$  in (5.76). To prove (5.38) consider

$$h(\{0\} \cup [n]) = h([n]) + f(\emptyset) \quad (5.78)$$

$$= h([n]), \quad (5.79)$$

where (5.78) follows by the definition of the set function  $h$  in (5.77) and (5.79) follows by (5.16). To prove (5.39), consider

$$h(\{i\} \cup A_i \cup \{0\}) = h(\{i\} \cup A_i) + f(B_i) \quad (5.80)$$

$$= h(\{i\} \cup A_i) + f(i \cup B_i) - h(\{i\}) \quad (5.81)$$

$$= h(A_i) + f(i \cup B_i) \quad (5.82)$$

$$= h(A_i \cup \{0\}), \quad (5.83)$$

where (5.81) follows by the definition in (5.76) and (5.82) follows by property (5.37) that we proved earlier. Before proving property (5.40), we prove that the set function  $h$  is submodular. Consider three cases. First, suppose that  $A, B \subseteq [n]$ .

Then

$$\begin{aligned}
& h(A \cap B) + h(A \cup B) \\
&= \sum_{i \in A \cap B} (f(\{i\} \cup B_i) - f(B_i)) + \sum_{i \in A \cup B} (f(\{i\} \cup B_i) - f(B_i)) \\
&= \sum_{i \in A} (f(\{i\} \cup B_i) - f(B_i)) + \sum_{i \in B} (f(\{i\} \cup B_i) - f(B_i)) \\
&= h(A) + h(B). \tag{5.84}
\end{aligned}$$

Second, suppose that  $A, B \subseteq \{0\} \cup [n]$  such that  $0 \in A$  and  $0 \notin B$ . Let  $A' = A \setminus \{0\}$ .

Then  $0 \in (A \cup B)$  and  $0 \notin (A \cap B)$ . Thus, we have

$$h(A \cap B) + h(A \cup B) \tag{5.85}$$

$$= h(A' \cap B) + h(A' \cup B) + f(\bar{A}' \cap \bar{B}) \tag{5.86}$$

$$= h(A') + h(B) + f(\bar{A}' \cap \bar{B}) \tag{5.87}$$

$$\leq h(A') + h(B) + f(\bar{A}') \tag{5.88}$$

$$= h(A) + h(B), \tag{5.89}$$

where (5.87) follows by (5.84) and (5.88) follows by (5.18). Finally, suppose that

$A, B \subseteq \{0\} \cup [n]$  such that  $0 \in A \cap B$ . Let  $A' = A \setminus \{0\}$  and  $B' = B \setminus \{0\}$ . Then

$$h(A \cap B) + h(A \cup B) \tag{5.90}$$

$$= h(A' \cap B') + f(\bar{A}' \cup \bar{B}') + h(A' \cup B') + f(\bar{A}' \cap \bar{B}') \tag{5.91}$$

$$= h(A') + h(B') + f(\bar{A}' \cup \bar{B}') + f(\bar{A}' \cap \bar{B}') \tag{5.92}$$

$$\leq h(A') + f(\bar{A}') + h(B') + f(\bar{B}') \tag{5.93}$$

$$= h(A) + h(B), \tag{5.94}$$

where (5.92) follows by (5.84) and (5.93) follows by submodularity of the set function  $f$  in (5.19). In summary, for any  $A, B \subseteq \{0\} \cup [n]$ ,

$$h(A \cap B) + h(A \cup B) \leq h(A) + h(B). \tag{5.95}$$

Property (5.40) follows by (5.95) by setting  $A = J \cup K$  and  $B = K \cup L$ , and the following

$$h(K) \leq h(K \cup (J \cap L)).$$

This completes the proof of the proposition.

# Chapter 6

## Coding Schemes

In this section, we review some of the most famous index coding schemes based on algebraic, graph-theoretic, and information-theoretic approaches. Each coding scheme corresponds to an upper bound on the broadcast rate or a lower bound on the capacity (inner bound on the capacity region).

### 6.1 MDS Code

Consider the 3-message index coding problem represented by the side information graph shown in Figure 6.1, in which every receiver has one piece of side information. Consider a  $(5, 3)$  systematic MDS code  $(x_1, x_2, x_3, p_1, p_2)$  over the finite field  $\mathbb{F}_4 = \{0, 1, \alpha, \alpha + 1\}$ , where  $p_1 = x_1 + x_2 + x_3$  and  $p_2 = x_1 + \alpha x_2 + (\alpha + 1)x_3$ . This code has the property that any three out of the five code symbols are sufficient to recover the three message symbols. We can employ this code for the 3-message index coding problem and transmit the parities  $p_1$  and  $p_2$ . Then, every receiver will have three code symbols and can successfully recover its desired message.

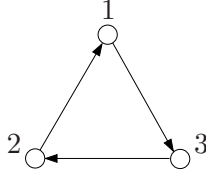

**Figure 6.1:** A 3-message index coding problem with  $\beta = 2$ , which is achievable by a  $(5, 3)$  MDS code.

For a general index coding problem  $G$ , let

$$\text{minindeg}(G) := \min_{i \in [n]} |\{j : (j, i) \in E(G)\}|$$

be the minimum number of side information messages over all receivers. Consider a systematic  $(n + d, n)$  MDS code with  $n$  message symbols and  $d$  parity symbols. Then, Given any  $n$  out of the  $n + d$  code symbols, one can recover all the messages. Such MDS code exists over a sufficiently large alphabet size. As every receiver has at least  $\text{minindeg}(G)$  messages as side information, if we employ the  $(n + d, n)$  MDS code and transmit  $d = n - \text{minindeg}(G)$  parities, then every receiver will have  $n$  code symbols and thus can recover all the message symbols that it does not have including its desired message. This establishes the following upper bound on the broadcast rate.

**Proposition 6.1** ([3]). *For any  $G$  with  $|V(G)| = n$ ,  $\beta(G) \leq \beta_{\text{MDS}}(G) = n - \text{minindeg}(G)$ .*

**Remark 6.1.** If the graph  $G$  is a clique, then  $\text{minindeg}(G) = n - 1$  and it suffices to transmit the parity symbol  $x_1 + \dots + x_n$  of an  $(n + 1, n)$  MDS code and achieve  $\beta(G) = 1$ .

## 6.2 Clique Covering

Consider the side information graph  $G$  shown in Figure 6.2. Since receiver 3 has no side information we have  $\text{mininddeg}(G) = 0$ . Therefore, using an MDS code we need to transmit three symbols, which is no better than uncoded transmission of the messages and is not optimal. Assume that  $x_i \in \mathbb{F}_2, i \in [3]$ . We can partition the vertices into two cliques, namely,  $\{1, 2\}$  and  $\{3\}$ , and transmit  $x_1 + x_2$  and  $x_3$ . Then, receiver 3 receives its desired message  $x_3$  directly. Since receiver 1 has message  $x_2$  as side information, it can successfully recover its desired message  $x_1$ . Similarly, receiver 2 can recover its desired message  $x_2$ . This scheme requires two transmissions, which matches the MAIS outer bound for this problem and is thus optimal.

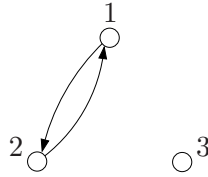

**Figure 6.2:** A three message side information graph with  $\beta = 2$  that is achievable by the clique covering scheme.

Generalizing this idea, we partition the vertices of the side information graph  $G$  by cliques and transmit the binary sums (parities) of all the messages in each clique. Since every receiver has all the other messages inside its clique as side information, all the messages can be successfully recovered by their corresponding receivers. This coding scheme, which can be viewed as *time division* over a clique partition (one parity bit per clique), achieves the following *clique covering* bound on the broadcast rate.

**Proposition 6.2** (Birk and Kol [3]). *The broadcast rate is upper bounded by the minimum number of cliques that partition  $G$  (or equivalently, the chromatic number*



of the undirected complement of  $G$ ) which is the solution  $\beta_C$  to the integer program

$$\begin{aligned}
 & \text{minimize} && \sum_{J \in \mathcal{K}} \rho_J \\
 & \text{subject to} && \sum_{J \in \mathcal{K}: i \in J} \rho_J \geq 1, \quad i \in [n], \\
 & && \rho_J \in \{0, 1\}, \quad J \in \mathcal{K},
 \end{aligned} \tag{6.1}$$

where  $\mathcal{K}$  is the collection of all cliques in  $G$ .

**Remark 6.2.** For the problem with side information graph as shown in Figure 6.1, using an MDS code requires two transmissions, whereas clique covering scheme requires three transmissions and thus, MDS code outperforms the clique covering scheme. Therefore, the clique covering scheme and the MDS code for index coding are not comparable.

### 6.3 Fractional Clique Covering

Consider the side information graph shown in Figure 6.3. We can partition the graph into three cliques, say  $\{1, 2\}$ ,  $\{3, 4\}$ , and  $\{5\}$  and thus, by the clique covering scheme, it suffices to make three transmissions. However, this scheme is not optimal for this problem. Assume  $x_i = (x_{i1}, x_{i2}) \in \mathbb{F}_2^2$ , and consider the following vector linear coding scheme. If we transmit  $x_{11} + x_{21}$ ,  $x_{22} + x_{31}$ ,  $x_{32} + x_{41}$ ,  $x_{42} + x_{51}$ ,  $x_{52} + x_{12}$ , then every receiver can successfully recover its two bits. This scheme achieves the bound of  $5/2$  on the broadcast rate, which matches the polymatroidal bound (see Example 5.2).

In general, Blasiak, Kleinberg, and Lubetzky [23] extended (6.1) by considering *time sharing* over all cliques so that the combined rate of each message over all parities it participates in is at least one. The resulting rate  $\beta_F$  corresponds

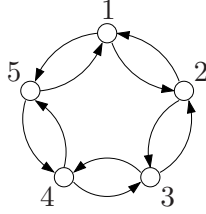

**Figure 6.3:** A five-message side information graph with  $\beta = 2.5$  that is achievable by the fractional clique covering scheme.

to the solution to the linear program obtained by relaxing the integer constraint  $\rho_J \in \{0, 1\}$  in (6.1), which is equivalent to the *fractional chromatic number* of the undirected complement of  $G$ .

**Proposition 6.3** (Blasiak, Kleinberg, and Lubetzky [23]). *The broadcast rate is upper bounded by the minimum number of cliques that fractionally partition  $G$  (or equivalently, the fractional chromatic number of the undirected complement of  $G$ ) which is the solution  $\beta_{\mathbb{F}}$  to the linear program*

$$\begin{aligned}
 & \text{minimize} && \sum_{J \in \mathcal{K}} \rho_J \\
 & \text{subject to} && \sum_{J \in \mathcal{K}: i \in J} \rho_J \geq 1, \quad i \in [n], \\
 & && \rho_J \in [0, 1], \quad J \in \mathcal{K},
 \end{aligned} \tag{6.2}$$

where  $\mathcal{K}$  is the collection of all cliques in  $G$ .

For the example at the beginning of this section, using the vector linear code is equivalent to setting

$$\rho(J) = \begin{cases} 1/2 & J = \{1, 2\}, \{2, 3\}, \{3, 4\}, \{4, 5\}, \{1, 5\}, \\ 0 & \text{otherwise,} \end{cases}$$

which satisfies the constraints of (6.2) and establishes the upper bound of  $5/2$  on

the broadcast rate.

## 6.4 Fractional Local Clique Covering

Consider the index coding problem

$$(1|2, 3, 4), (2|1, 3, 4), (3|4, 5, 6), (4|3, 5, 6), (5|1, 2, 6), (6|1, 2, 5),$$

with side information graph  $G$  shown in Figure 6.4. Assume  $x_i \in \mathbb{F}_2, i \in [6]$ . The side information graph  $G$  can be partitioned into three cliques  $\{1, 2\}, \{3, 4\}$ , and  $\{5, 6\}$ , and hence, by the clique covering scheme, it suffices to transmit parities  $x_1 + x_2, x_3 + x_4$ , and  $x_5 + x_6$ . However, since only two of the three parities are missing at each receiver, we can reduce the number of parity transmissions by using a two-erasure correcting MDS code with two hyperparity symbols, say,  $(x_1 + x_2) + (x_3 + x_4)$  and  $(x_1 + x_2) + (x_5 + x_6)$ .

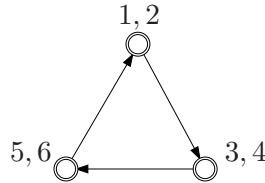

**Figure 6.4:** A six-message side information graph for which  $\beta_{\text{FL}} = 2 < \beta_{\text{comp}} = 3$ .

In general, Shanmugam, Dimakis, and Langberg [61] extended the clique covering scheme to *local clique covering*, whereby an MDS code is applied to parity symbols for cliques. This improves upon the clique covering scheme since each receiver can recover some parity symbols from its side information and thus the total transmission time is now shared only among those parity symbols not available locally at each receiver. Further extending this scheme with fractional coloring,

yields the following.

**Proposition 6.4** (Shanmugam, Dimakis, and Langberg [61]). *The broadcast rate is upper bounded by the solution  $\beta_{\text{FL}}$  to the linear program*

$$\begin{aligned} & \text{minimize} && \max_{i \in [n]} \sum_{J \in \mathcal{K}: J \not\subseteq A_i} \rho_J \\ & \text{subject to} && \sum_{J \in \mathcal{K}: i \in J} \rho_J \geq 1, \quad i \in [n], \\ & && \rho_J \in [0, 1], \quad J \in \mathcal{K}. \end{aligned} \tag{6.3}$$

This coding scheme achieves the *fractional local chromatic number* [62, 63] of the directed complement of  $G$ . The improvement over time sharing is captured by the summation of  $\rho_J$  over cliques  $J \not\subseteq A_i$  compared to the summation over all cliques  $J$  in (6.2).

## 6.5 Fractional Local Partial Clique Covering

Birk and Kol [3] extended the clique covering scheme in Section 6.2 by performing time division over arbitrary subgraphs instead of cliques. A general graph  $G$  with  $n$  vertices is referred to as a *partial clique* with parameter  $\kappa(G)$ , where  $\kappa(G)$  is the number of parity symbols needed to send the messages of index coding problem  $G$  using an MDS code, i.e.,  $\kappa(G) = n - \text{minideg}(G)$ . Note that a partial clique with parameter 1 is a clique.

Consider the 5-message index coding problem  $G$  depicted in Figure 6.5. It can be shown that the fractional local clique covering scheme yields the upper bound of  $\beta_{\text{FL}}(G) = 4$ . This upper bound can be improved by performing local time sharing over partial cliques instead of cliques. We have  $\kappa(G|_{\{1,2\}}) = \kappa(G|_{\{1,5\}}) = \kappa(G|_{\{4\}}) = 1$  and  $\kappa(G|_{\{1,3,4\}}) = \kappa(G|_{\{2,3,5\}}) = 2$ . Setting  $\rho_J = 1/2$

if  $J = \{1, 2\}, \{1, 5\}, \{1, 3, 4\}, \{2, 3, 5\}$ , and  $\{4\}$ , and  $\rho_J = 0$ , otherwise, we can achieve the upper bound of  $7/2$  on the broadcast rate.

In general, local time sharing over MDS codes of arbitrary subgraphs (partial cliques) yields the following bound referred to as the *fractional local partial clique covering* bound.

**Theorem 6.1.** *The broadcast rate is upper bounded by the solution  $\beta_{\text{FLP}}$  to the linear program*

$$\begin{aligned} & \text{minimize} && \max_{i \in [n]} \sum_{J \subseteq [n]: J \not\subseteq A_i} \rho_J \cdot \kappa(G|_J) \\ & \text{subject to} && \sum_{J \subseteq [n]: i \in J} \rho_J \geq 1, \quad i \in [n], \\ & && \rho_J \in [0, 1], \quad J \subseteq [n]. \end{aligned} \tag{6.4}$$

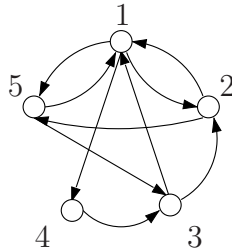

**Figure 6.5:** An index coding problem with  $\beta_{\text{FLP}} = 7/2 < \beta_{\text{FL}} = 4$ .

**Remark 6.3.** The fractional local partial clique covering bound can be readily extended to the corresponding inner bound on the capacity region. A rate tuple  $(R_1, \dots, R_n)$  is achievable by fractional local partial clique covering for the index coding problem  $(i|A_i), i \in [n]$ , if there exists  $(\rho_J \in [0, 1], J \subseteq [n])$  such that

$$\begin{aligned} & \max_{i \in [n]} \sum_{J \subseteq [n]: J \not\subseteq A_i} \rho_J \cdot \kappa(G|_J) \leq 1 \\ & R_i \leq \sum_{J \subseteq [n]: i \in J} \rho_J, \quad i \in [n]. \end{aligned} \tag{6.5}$$

## 6.6 General Linear Codes

We revisit the index coding problem  $(1|2), (2|3), (3|1)$  with side information graph shown in Figure 6.1. Consider any 3-by-3 matrix  $M$  such that

$$M_{ii} = 1 \quad \text{and} \quad M_{ij} = 0 \text{ if } j \notin A_i. \quad (6.6)$$

We can easily check that matrices

$$M_1 = \begin{pmatrix} 1 & 1 & 0 \\ 0 & 1 & 1 \\ 1 & 0 & 1 \end{pmatrix} \quad \text{and} \quad M_2 = \begin{pmatrix} 1 & 0 & 0 \\ 0 & 1 & 0 \\ 1 & 0 & 1 \end{pmatrix}$$

satisfy such constraints. Consider the three linear combinations of the messages generated by multiplying any such matrix  $M$  from left by the message vector  $(x_1, x_2, x_3)^T$ . For example,  $M_1$  generates  $x_1 + x_2$ ,  $x_2 + x_3$ , and  $x_1 + x_3$ , and  $M_2$  generates  $x_1$ ,  $x_2$ , and  $x_1 + x_3$ . If we transmit these three generated symbols, receiver  $i$  can use the linear combination from row  $i$  to recover  $x_i$  since it contains only  $x_i$  and  $x(A_i)$ . Now note that  $M_1$  is of rank 2 and thus that any two of the three linear combinations can determine the third; for example  $x_1 + x_3 = (x_1 + x_2) + (x_2 + x_3)$ . Thus, it suffices to transmit the first two generated symbols. More generally, if  $M$  is of rank  $r$ , then we can transmit linear combinations of the messages from  $r$  independent rows of  $M$ . Therefore, any matrix  $M$  satisfying (6.6) and the associated generated symbols define a scalar linear code and  $\text{rank}(M)$  is an upper bound on the scalar linear broadcast rate  $\beta_L(G; 1, 2)$  and thus on the broadcast rate. We can optimize over all matrices  $M$  satisfying (6.6) to minimize the rank.

For a general index coding problem with side information graph  $G$ , its

*minrank*, which is defined by Bar-Yossef, Birk, Jayram, and Kol [25] as

$$\text{minrank}_2(G) = \min\{\text{rank}(M) : M_{ij} \in \mathbb{F}_2, M \text{ satisfies (6.6)}\},$$

yields an upper bound on the broadcast rate, i.e.,

$$\beta(G) \leq \beta_L(G; 1, 2) \leq \text{minrank}_2(G). \quad (6.7)$$

Lubetzky and Stav [26] extended this scheme by considering matrices on a larger field  $\mathbb{F}_q$  satisfying

$$M_{ii} \neq 0 \quad \text{and} \quad M_{ij} = 0 \text{ if } j \notin A_i, \quad (6.8)$$

and obtained a tightened upper bound as

$$\begin{aligned} \beta(G) &\leq \beta_L(G; 1, q) \\ &\leq \text{minrank}_q(G) = \min\{\text{rank}(M) : M_{ij} \in \mathbb{F}_q, M \text{ satisfies (6.8)}\}. \end{aligned}$$

Conversely, consider a scalar linear index code over the finite field  $\mathbb{F}_q$  with length  $r$ . Since each receiver  $i \in [n]$  can recover message  $x_i$ , there is always a linear combination of the codewords that contains only  $x_i$  and  $x(A_i)$  and thus, we can construct a matrix with rank  $r$  that satisfies (6.8). By the definition of the minrank,  $r \geq \text{minrank}_q(G)$  which implies  $\beta_L(G; 1, q) \geq \text{minrank}_q(G)$ . Therefore,  $\text{minrank}_q(G)$  characterizes the scalar linear broadcast rate over the finite field  $\mathbb{F}_q$  for index coding problem  $G$ .

**Proposition 6.5.** *For any index coding problem  $G$ ,*

$$\beta_L(G; 1, q) = \text{minrank}_q(G).$$

Lubetzky and Stav [26] also demonstrated that for some index coding problems, the performance can be significantly improved by partitioning  $G$  into subgraphs and using fields of distinct characteristics over each subgraph. This leads to the following which implies insufficiency of scalar linear codes.

**Proposition 6.6** ([26]). *For any  $\epsilon > 0$  and any sufficiently large  $n$ , there is an index coding problem  $G$  with  $n$  messages so that  $\beta_L(G; 1, q) = \text{minrank}_q(G) \geq \sqrt{n}$  for any field  $\mathbb{F}_q$ , while  $\beta(G) \leq n^\epsilon$ .*

Motivated by interference alignment coding schemes in wireless interference channels [64, 65], Jafar [66, Section 4.10] proposed to extend minrank by using message symbols in  $\mathbb{F}_q^t$ , namely, using  $t$ -by- $t$  matrices in place of  $M_{ij}$ ,  $1 \leq i, j \leq n$ , in (6.8). The rank of the resulting  $nt$ -by- $nt$  matrix provides an upper bound on the broadcast rate. Note that since  $t$  can be arbitrary, it is impossible to use this idea to find the best (vector) linear code.

El-Rouayheb, Sprintson, and Georghiades [21] and Blasiak, Kleinberg, and Lubetzky [37] presented examples where nonlinear index codes outperform vector linear index codes for any choice of field and message length  $t$ . However, in these examples it is assumed that a message may be requested by more than one receiver (multiple groupcast), whereas in our setup we assumed that each receiver is interested in a unique message (multiple unicast). Maleki, Cadambe, and Jafar [32] proved that linear coding is insufficient to achieve the capacity region of the multiple unicast index coding problem by associating a multiple unicast problem to an arbitrary groupcast setting.



## 6.7 Flat Coding

In this and the next section, we use Shannon’s random coding idea [67] to prove the existence of index codes of certain rates. Despite its conceptual simplicity, this fresh angle allows for rather straightforward derivation of an achievable rate region, i.e. an inner bound on the capacity region, without the complexity of code construction.

We first illustrate a simple random coding scheme, referred to as *flat coding*, through an example. Consider the index coding problem  $(1|2), (2|1, 3), (3|1)$  with side information graph depicted in Figure 6.6. We use the following random coding argument to find conditions under which a rate triple  $(R_1, R_2, R_3) \in [0, 1]^3$  is achievable. Fix an integer  $r$  and let  $t_i = \lceil rR_i \rceil, i \in [3]$ . For each message triple  $(x_1, x_2, x_3) \in \Pi_{i=1}^3[2^{t_i}]$ , generate a codeword  $y(x_1, x_2, x_3)$  drawn uniformly at random from  $[2^r]$ . Note that codebook generation is “flat” over all messages; hence this scheme is called flat coding. To communicate message triple  $(x_1, x_2, x_3)$ , we transmit  $y = y(x_1, x_2, x_3)$ .

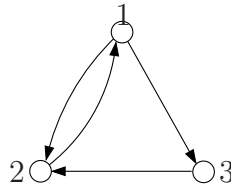

**Figure 6.6:** A 3-message index coding instance for which the flat coding is optimal.

Let  $B_i = [n] \setminus (\{i\} \cup A_i)$  denote the set of interfering messages at receiver  $i$ ,  $i \in [n]$ . Each receiver uses the received sequence  $y$  and its side information  $x(A_i)$  to uniquely recover all the messages that are not in its side information set, namely, receiver  $i$  finds the unique  $(\hat{x}_i, \hat{x}(B_i))$  such that  $y(\hat{x}_i, x(A_i), \hat{x}(B_i)) = y$ . Let  $P_i$  be the probability of error at receiver  $i \in [3]$ . Assuming that the true message

triple is  $(x_1, x_2, x_3)$ , receiver  $i$  makes an error if there is another message triple  $(\hat{x}_1, \hat{x}_2, \hat{x}_3) \neq (x_1, x_2, x_3)$  such that  $y(\hat{x}_1, \hat{x}_2, \hat{x}_3) = y(x_1, x_2, x_3)$ . By symmetry, the probability of error averaged over message triple and codebooks is equal to the probability of error given a particular message triple  $(x_1, x_2, x_3)$ . For brevity, we do not explicitly mention the condition. For example, receiver 1, which has  $x_2$  as side information, finds the unique  $(\hat{x}_1, \hat{x}_3)$  such that  $y(\hat{x}_1, x_2, \hat{x}_3) = y$ .

By the union bound,

$$P_1 = \mathbb{P}\{y(\hat{x}_1, x_2, \hat{x}_3) = y \text{ for some } (\hat{x}_1, \hat{x}_3) \neq (x_1, x_3)\} \\ \leq \frac{2^{t_1} 2^{t_3}}{2^r} \tag{6.9}$$

$$\leq \frac{2^{rR_1+1} 2^{rR_3+1}}{2^r}, \tag{6.10}$$

where (6.9) holds since the number of wrong triples is  $2^{t_1} 2^{t_3} - 1$  and codewords assigned to two different message triples are the same with probability  $\frac{1}{2^r}$ . Thus,  $P_1$  tends to zero as  $r \rightarrow \infty$  if  $R_1 + R_3 < 1$ . Similarly,  $P_2$  and  $P_3$  tend to zero as  $r \rightarrow \infty$  if  $R_2 < 1$  and  $R_2 + R_3 < 1$ , respectively. Thus, by the union of events bound, if  $R_1 + R_3 < 1$ ,  $R_2 < 1$ , and  $R_2 + R_3 < 1$ , the probability of error averaged over codebooks tends to zero as  $r \rightarrow \infty$ . Therefore, there must exist a sequence of  $(\lceil rR_1 \rceil, \dots, \lceil rR_n \rceil, r)$  index codes such that the average probability of error  $\mathbf{P}^{(r)}$  tends to zero as  $r \rightarrow \infty$ . By invoking Lemma 1.2, this error probability can be made to be zero. Therefore, the flat coding upper bound on the broadcast rate is 2 and the flat coding inner bound on the capacity region is characterized as the

set of rate triples  $(R_1, R_2, R_3)$  such that

$$\begin{aligned} R_1 + R_3 &\leq 1, \\ R_2 &\leq 1, \\ R_2 + R_3 &\leq 1. \end{aligned} \tag{6.11}$$

Since the subgraphs  $G|_{\{1,3\}}$  and  $G|_{\{2,3\}}$  are acyclic, the inner bound in (6.11) matches the MAIS outer bound, characterizing the capacity region of the problem.

In general, consider an index coding problem with  $n$  messages and let  $(R_1, \dots, R_n) \in [0, 1]^n$  be a rate tuple. Fix an integer  $r$  and let  $t_i = \lceil rR_i \rceil, i \in [n]$ .

**Codebook generation.** For each  $(x_1, \dots, x_n) \in [2^{t_1}] \times \dots \times [2^{t_n}]$ , generate a codeword  $y(x_1, \dots, x_n)$  drawn uniformly at random from  $[2^r]$ .

**Encoding.** To communicate message tuple  $(x_1, \dots, x_n)$ , the sender transmits  $y = y(x_1, \dots, x_n)$ .

**Decoding.** Receiver  $i$  finds the unique  $(\hat{x}_i, \hat{x}(B_i))$  such that  $y(\hat{x}_i, x(A_i), \hat{x}(B_i))$  is identical to the received sequence  $y$ , where  $B_i = [n] \setminus (\{i\} \cup A_i)$ .

**Analysis of the probability of error.** Denote the probability of error at receiver  $i \in [n]$  by  $P_i$ . Similar to (6.10), by the union bound,

$$\begin{aligned} P_i &= \mathbb{P}\{y(\hat{x}_i, x(A_i), \hat{x}(B_i)) = y \text{ for some } (\hat{x}_i, \hat{x}(B_i)) \neq (x_i, x(B_i))\} \\ &\leq \frac{2^{t_1} \times \dots \times 2^{t_n}}{2^r} \\ &\leq \frac{2^{rR_1+1} \times \dots \times 2^{rR_n+1}}{2^r}. \end{aligned} \tag{6.12}$$

Therefore,  $P_i$  tends to zero as  $r \rightarrow \infty$  if  $\sum_{j \notin A_i} R_j < 1$ . By taking similar steps as before, we can argue that the flat coding scheme yields the following bound.

**Proposition 6.7.** *The flat coding inner bound  $\mathcal{R}_{\text{flat}}$  on the capacity region of the index coding problem  $(i|A_i)$ ,  $i \in [n]$ , is characterized as the set of rate tuples  $(R_1, \dots, R_n)$  such that*

$$\sum_{j \notin A_i} R_j < 1, \quad i \in [n].$$

*In particular, for any index coding problem  $G$ ,*

$$\beta(G) \leq \beta_{\text{flat}}(G) := \max_{i \in V(G)} (n - |A_i|).$$

**Remark 6.4.** Note that for an index coding problem  $(i|A_i)$ ,  $i \in [n]$ , represented by side information graph  $G$ , we have  $\text{minindeg}(G) = \min_{i \in [n]} |A_i|$  and thus, the flat coding upper bound on the broadcast rate is identical to the bound established by the MDS codes (see Section 6.1), i.e., for any index coding problem  $G$ ,  $\beta_{\text{flat}}(G) = \beta_{\text{MDS}}(G)$ .

## 6.8 Composite Coding

For the index coding problem  $(1|4), (2|3, 4), (3|1, 2), (4|2, 3)$ , with side information graph  $G$  depicted in Figure 6.7,  $\beta_{\text{flat}}(G) = 3$  and the flat coding inner bound is characterized by

$$R_1 + R_2 + R_3 \leq 1,$$

$$R_3 + R_4 \leq 1,$$

$$R_1 + R_4 \leq 1.$$

However, flat coding is not optimal for this index coding instance. Assume  $x_i \in \mathbb{F}_2$ ,  $i \in [4]$ . If we transmit  $y_1 = x_1 + x_2 + x_3$  and  $y_2 = x_2 + x_3 + x_4$ , then every receiver can recover its desired message. Thus, this linear coding scheme yields the upper bound of 2 on the broadcast rate, which shows that flat coding is not optimal in general. In this section, we propose a more powerful random coding scheme, referred to as *composite coding*, that is built upon flat coding.

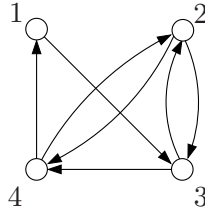

**Figure 6.7:** A 4-node index coding instance for which the flat coding scheme is not optimal.

To illustrate the composite coding scheme, we revisit the index coding problem with side information graph depicted in Figure 6.7. Consider a message rate tuple  $(R_1, \dots, R_4) \in [0, 1]^4$  and two composite rates  $S_{\{1,4\}}$  and  $S_{\{2,3,4\}}$ . Fix an integer  $r$  and let  $t_i = \lceil rR_i \rceil, i \in [4]$ , and  $s_J = \lceil rS_J \rceil, J \subseteq [4]$ . As the first step of composite coding, we map  $(x_1, x_4)$  to an index  $w_{\{1,4\}} = w_{\{1,4\}}(x_1, x_4)$  drawn uniformly at random from  $[2^{s_{\{1,4\}}}]$  (as in flat coding). Similarly, map  $(x_2, x_3, x_4)$  into random index  $w_{\{2,3,4\}} = w_{\{2,3,4\}}(x_2, x_3, x_4) \in [2^{s_{\{2,3,4\}}}]$ . As the second step of composite coding, we map  $w_{\{1,4\}}$  and  $w_{\{2,3,4\}}$  to a codeword  $y = y(w_{\{1,4\}}, w_{\{2,3,4\}})$  drawn uniformly at random from  $[2^r]$  (as in flat coding) and transmit it.

Decoding is also performed in two steps. Each receiver  $i$  first recovers  $(w_{\{1,4\}}, w_{\{2,3,4\}})$  from  $y$ , which, by Proposition 6.7, is successful with vanishing probability of error as  $r \rightarrow \infty$  if

$$S_{\{1,4\}} + S_{\{2,3,4\}} < 1.$$

Then receiver  $i$  recovers  $x_i$  and some other messages simultaneously using  $w_{\{1,4\}}$ ,  $w_{\{2,3,4\}}$ , and  $x(A_i)$ . By Proposition 6.7, receiver 1 recovers  $x_1$  from  $w_{\{1,4\}}$  and side information  $x_4$  with vanishing probability of error if

$$R_1 < S_{\{1,4\}}.$$

Again by Proposition 6.7, receiver 2 recovers  $x_2$  from  $w_{\{2,3,4\}}$  and side information  $x_3$  and  $x_4$  with vanishing probability of error if

$$R_2 < S_{\{2,3,4\}}$$

and receiver 4 recovers  $x_4$  from  $w_{\{2,3,4\}}$  and side information  $x_2$  and  $x_3$  with vanishing probability of error if

$$R_4 < S_{\{2,3,4\}}.$$

Receiver 3 recovers  $x_3$  and  $x_4$  from  $w_{\{1,4\}}$  and  $w_{\{2,3,4\}}$  and side information  $x_1$  and  $x_2$ . It can be shown by Proposition 6.8 stated later that the decoding is successful with vanishing probability of error if

$$R_3 + R_4 < S_{\{1,4\}} + S_{\{2,3,4\}},$$

$$R_3 < S_{\{2,3,4\}},$$

$$R_4 < S_{\{1,4\}} + S_{\{2,3,4\}}.$$

Summarizing these conditions, we can achieve any rate tuple  $(R_1, R_2, R_3, R_4)$  sat-

isfying

$$\begin{aligned}
R_1 &< S_{1,4}, \\
R_2 &< S_{2,3,4}, \\
R_3 + R_4 &< S_{1,4} + S_{2,3,4}, \\
R_3 &< S_{2,3,4}, \\
R_4 &< S_{2,3,4}
\end{aligned}$$

for some  $S_{1,4} > 0$  and  $S_{2,3,4} > 0$  such that

$$S_{1,4} + S_{2,3,4} < 1.$$

After Fourier–Motzkin elimination of  $(S_{1,4}, S_{2,3,4})$ , the resulting composite coding inner bound on the capacity region is characterized by

$$\begin{aligned}
R_1 + R_2 &< 1, \\
R_1 + R_3 &< 1, \\
R_1 + R_4 &< 1, \\
R_3 + R_4 &< 1.
\end{aligned}$$

In particular, the broadcast rate of 2 is achievable.

We now generalize the coding scheme by introducing composite indices for each nonempty subset  $J$  of  $[n]$  and optimizing over the decoding set at each receiver. Consider a message rate tuple  $(R_1, \dots, R_n) \in [0, 1]^n$  and a composite rate tuple  $\mathbf{S} = (S_J : J \subseteq [n], J \neq \emptyset) \in [0, 1]^{2^n - 1}$ . Fix an integer  $r$  and let  $t_i = \lceil rR_i \rceil, i \in [n]$ , and  $s_J = \lceil rS_J \rceil, J \subseteq [n]$ . We first decompose the encoder into  $2^n - 1$  virtual en-

coders. Virtual encoder  $J$  generates composite message  $w_J(x(J))$  of rate  $S_J$  using flat coding over  $x(J)$ . Next, the composite messages are encoded into a single index  $y$  using flat coding over all composite indices. Decoding is also performed in two steps. First, each receiver  $i$  uses its side information  $x(A_i)$  to recover  $(w_J, J \subseteq [n])$  from  $y$ . Next, receiver  $i$  recovers a subset of messages  $x(D_i)$  including its required message  $x_i$ , from  $(w_J, J \subseteq [n])$  and  $x(A_i)$ . Figure 6.8 illustrates the composite coding scheme. The details are as follows.

**Codebook generation.** Step 1. For each  $x(J)$ ,  $J \subseteq [n]$ , generate a composite message  $w_J(x(J))$  drawn uniformly at random from  $[2^{s_J}]$ .

Step 2. For each  $(w_J, J \subseteq [n])$ , generate a codeword  $y(w_J, J \subseteq [n])$  drawn uniformly at random from  $[2^r]$ .

**Encoding.** To communicate message tuple  $(x_1, \dots, x_n)$ , the sender transmits  $y = y(w_J, J \subseteq [n])$ .

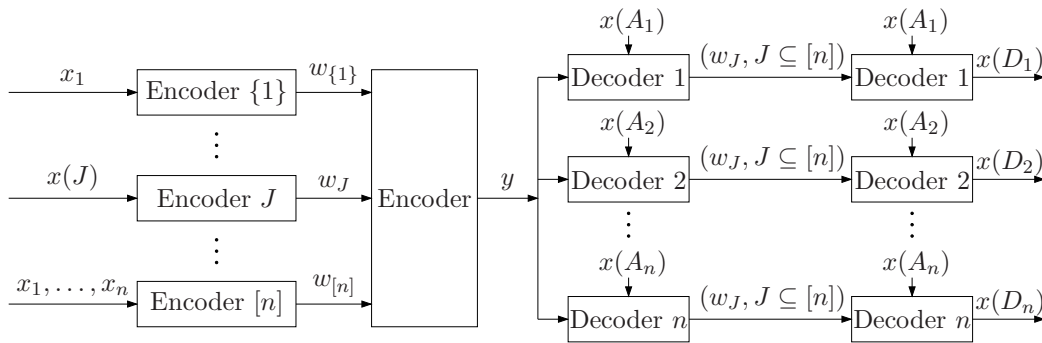

**Figure 6.8:** Composite coding scheme

**Decoding.** Step 1. Receiver  $i$  finds the unique  $(\hat{w}_J, J \not\subseteq A_i)$  such that  $y((\hat{w}_J, J \not\subseteq A_i), (w_J, J \subseteq A_i))$  is identical to the received sequence  $y$ . Step 2. Fix the decoding set  $D_i$  at receiver  $i$  such that  $i \in D_i \subseteq [n] \setminus A_i$ . Assuming that  $(\hat{w}_J, J \subseteq [n])$  is



correct, receiver  $i$  recovers  $x(D_i)$  from  $(\hat{w}_J, J \subseteq [n])$  and  $x(A_i)$ .

**Analysis of the probability of error.** By Proposition 6.7, the probability of error in the first step of decoding tends to zero as  $r \rightarrow \infty$  if

$$\sum_{J \not\subseteq A_i} S_J < 1. \quad (6.13)$$

To analyze the probability of error at the second step, we digress a bit to discuss the communication problem depicted in Figure 6.9. Since this is a many-to-one communication, it is “dual” to the index coding problem in some sense. Here a set of  $(2^n - 1)$  servers wish to communicate a message tuple  $(x_1, \dots, x_n)$  to a common receiver through a noiseless multiple access channel (MAC), each encoding a subtuple  $x(J)$  into a separate index  $w_J$  with rate  $S_J$ . The receiver has a set of messages  $x(A)$ ,  $A \subseteq [n]$ , as side information and wishes to recover another set of messages  $x(D)$ ,  $D \subseteq [n] \setminus A$ . The question is to characterize the capacity region as a function of the rate tuple  $(S_J, J \subseteq [n])$ . When  $D = [n]$  and  $A = \emptyset$ , this problem is a special case of the general multiple access channel with correlated messages studied by Han [68] and the capacity region can be generalized to arbitrary  $A$  and  $D$  by a straightforward adaptation of the result in [68]. Here we present an achievable rate region for general  $A$  and  $D$  via flat coding that is tight for  $A = \emptyset$  and  $D = [n]$  and can be easily extended to multiple receivers with different decoding sets; see Appendix 6.A for the proof.

**Proposition 6.8.** *The capacity region of the dual index coding problem is the set of rate tuples  $(R_1, \dots, R_n)$  that satisfy*

$$\sum_{i \in K} R_i \leq \sum_{J \subseteq D \cup A: J \cap K \neq \emptyset} S_J \quad (6.14)$$

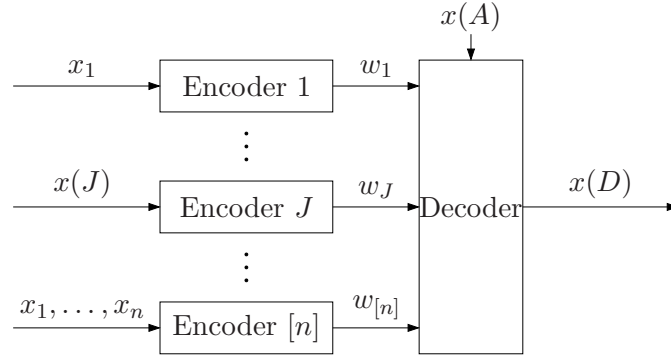

**Figure 6.9:** The “dual” index coding problem.

for all  $K \subseteq D$ .

Now we return to the analysis of the second step of the composite coding scheme. Each receiver  $i$  in our composite coding scheme can be viewed as the receiver in the “dual” index coding problem with side information set  $A_i$  and decoding set  $D_i$ . Hence, by the random coding proof of Proposition 6.8, the probability of error at receiver  $i$  tends to zero as  $r \rightarrow \infty$  if

$$\sum_{i \in K} R_i < \sum_{J \subseteq D_i \cup A_i: J \cap K \neq \emptyset} S_J \quad (6.15)$$

for all  $K \subseteq D_i$ . Therefore, by the union of events bound and the standard argument as in the analysis of flat coding in Section 6.7, we can achieve any rate tuple  $(R_1, \dots, R_n)$  that satisfies (6.15) for some  $(S_J, J \neq \emptyset, J \subseteq [n])$  satisfying (6.13). For each  $\mathbf{S} = (S_J, J \neq \emptyset, J \subseteq [n])$  satisfying (6.13), let  $\mathcal{R}_{D_i|A_i}(\mathbf{S})$  be the polymatroidal rate region defined by (6.15). Rewriting the achievable rate region in terms of  $\mathcal{R}_{D_i|A_i}(\mathbf{S})$  and optimizing over  $D_i$ , we have the following.

**Theorem 6.2.** *The composite coding inner bound  $\mathcal{R}_{\text{comp}}$  on the capacity region of the index coding problem  $(i|A_i)$ ,  $i \in [n]$ , is the convex hull of the set of rate tuples*

$(R_1, \dots, R_n)$  in

$$\bigcup_{(D_1, \dots, D_n) \in \Delta} \bigcup_{\mathbf{S} \in \Sigma} \bigcap_{i \in [n]} \mathcal{R}_{D_i|A_i}(\mathbf{S}) \quad (6.16)$$

where  $\Delta = \{(D_1, \dots, D_n) : i \in D_i\}$  and  $\Sigma = \{\mathbf{S} : \mathbf{S} \text{ satisfies (6.13)}\}$ . In particular, the broadcast rate is upper bounded by

$$\beta_{\text{comp}} = \min_{R: (R, \dots, R) \in \mathcal{R}_{\text{comp}}} \frac{1}{R}. \quad (6.17)$$

**Remark 6.5.** In computing the composite coding inner bound  $\mathcal{R}_{\text{comp}}$ , taking the union over all vectors  $\mathbf{S} \in \Sigma$  is equivalent to Fourier–Motzkin elimination of these variables using linear inequalities (6.13) and (6.15).

**Remark 6.6.** It can be easily verified that the composite coding inner bound  $\mathcal{R}_{\text{comp}}$  on the capacity region of the index coding problem  $(i|A_i)$ ,  $i \in [n]$ , can also be characterized as the convex hull of the set of rate tuples  $(R_1, \dots, R_n)$  in

$$\bigcup_{\mathbf{S} \in \Sigma} \bigcap_{i \in [n]} \bigcup_{D_i: i \in D_i} \mathcal{R}_{D_i|A_i}(\mathbf{S}) \quad (6.18)$$

$$= \bigcap_{i \in [n]} \bigcup_{D_i: i \in D_i} \bigcup_{\mathbf{S} \in \Sigma} \mathcal{R}_{D_i|A_i}(\mathbf{S}) \quad (6.19)$$

$$= \bigcup_{(D_1, \dots, D_n) \in \Delta} \bigcap_{i \in [n]} \bigcup_{\mathbf{S} \in \Sigma} \mathcal{R}_{D_i|A_i}(\mathbf{S}), \quad (6.20)$$

where  $\Delta = \{(D_1, \dots, D_n) : i \in D_i\}$  and  $\Sigma = \{\mathbf{S} : \mathbf{S} \text{ satisfies (6.13)}\}$ .

**Remark 6.7.** For  $(D_1, \dots, D_n) \in \Delta$ , the broadcast rate is upper bounded by the

solution  $\beta_{\text{comp}}(D_1, \dots, D_n)$  to the linear program

$$\begin{aligned}
& \text{minimize } \max_{i \in [n]} \sum_{J \subseteq [n]: J \not\subseteq A_i} \gamma_J \\
& \text{subject to } \min_{K \subseteq D_i} \frac{1}{|K|} \sum_{J \subseteq D_i \cup A_i: J \cap K \neq \emptyset} \gamma_J \geq 1, \quad i \in [n], \\
& \gamma_J \geq 0, \quad J \subseteq [n],
\end{aligned} \tag{6.21}$$

and thus by

$$\beta'_{\text{comp}} = \min_{(D_1, \dots, D_n) \in \Delta} \beta_{\text{comp}}(D_1, \dots, D_n). \tag{6.22}$$

The upper bound in (6.22) can be strictly larger than the one in (6.17) as illustrated by the following.

**Example 6.1.** For the index coding problem

$$(1|4, 5), (2|1, 6), (3|1, 2, 4), (4|1, 2, 3), (5|2, 3), (6|3, 4),$$

$\beta_{\text{comp}} = 10/3$ , whereas  $\beta'_{\text{comp}} = 3.5$  which is achieved by the following two decoding set tuples, (which only differ in  $D_5$ ),

$$\begin{aligned}
D_1 &= \{1\}, D_2 = \{2, 5\}, D_3 = \{3, 5, 6\}, \\
D_4 &= \{4, 5, 6\}, D_5 = \{5\}, D_6 = \{6\},
\end{aligned}$$

and

$$\begin{aligned}
D_1 &= \{1\}, D_2 = \{2, 5\}, D_3 = \{3, 5, 6\}, \\
D_4 &= \{4, 5, 6\}, D_5 = \{5, 6\}, D_6 = \{6\}.
\end{aligned}$$

**Remark 6.8.** In the composite coding inner bound in Theorem 6.2 and Remark 6.6, the choice of  $\mathbf{S} = (S_J, J \neq \emptyset, J \subseteq [n])$  does not depend on the chosen decoding set tuple  $(D_1, \dots, D_n)$ . The scheme can potentially be enhanced by associating a vector  $\mathbf{S}(D_1, \dots, D_n)$  to each decoding set tuple  $(D_1, \dots, D_n)$  such that  $(S_J, J \neq \emptyset, J \subseteq [n]), S_J = \sum_{(D_1, \dots, D_n) \in \Delta} S_J(D_1, \dots, D_n)$ , satisfy (6.13) [69].

Note that if  $A_j \subseteq \{i\} \cup A_i$  for some  $i, j \in [n]$ , then receiver  $i$  has enough side information to use the decoding function of receiver  $j$  to recover  $x_j$ . Thus, there is no harm in adding  $j$  to the decoding set  $D_i$  of receiver  $i$ . Generalizing this concept, given an index coding problem  $G$  with side information sets  $A_1, \dots, A_n$ , Algorithm 1 generates a tuple of decoding sets which we refer to as the *natural decoding sets*.

---

**Algorithm 1:** Construction of natural decoding sets

---

**input:** Side information sets  $A_1, \dots, A_n$

**output:** Natural decoding sets  $N_1, \dots, N_n$

Step 1) Set  $N_i = \{i\}, i \in [n]$ .

Step 2) If there exists  $i, j$  such that  $A_j \subseteq A_i \cup N_i$  then  $N_i \leftarrow N_i \cup \{j\}$  and repeat step 2. Otherwise, done!

---

**Remark 6.9.** It can be easily shown that step 2 in Algorithm 1 is equivalent to the following.

Step 2') If there exists  $i, j$  such that  $A_j \subseteq A_i \cup N_i$  then  $N_i \leftarrow N_i \cup N_j$  and repeat step 2'. Otherwise, done!

**Example 6.2.** For the index coding problem

$$(1|4, 5), (2|1, 6), (3|1, 2, 4), (4|1, 2, 3), (5|2, 3), (6|3, 4),$$

the natural decoding sets are as follows:

$$N_1 = \{1\}, N_2 = \{2\}, N_3 = \{3, 5, 6\}, N_4 = \{4, 5, 6\}, N_5 = \{5\}, N_6 = \{6\}.$$

Given a decoding set tuple  $(D_1, \dots, D_n)$ , let  $\mathcal{R}(D_1, \dots, D_n)$  be the set of all rate tuples satisfying (6.15) for some  $(S_J, J \subseteq [n])$  satisfying (6.13).

**Proposition 6.9.** *Let  $(D_1, \dots, D_n)$  be a tuple of decoding sets such that  $N_i \setminus D_i \neq \emptyset$  for some  $i \in [n]$ . Then, there exists a tuple of decoding sets  $(D'_1, \dots, D'_n)$  satisfying*

$$N_i \subseteq D'_i, \quad i \in [n] \tag{6.23}$$

*such that  $\mathcal{R}(D_1, \dots, D_n) \subseteq \mathcal{R}(D'_1, \dots, D'_n)$ .*

The proof of the proposition is relegated to Appendix 6.B. We refer to a decoding set tuple that satisfy (6.23) as a superset of the natural decoding sets. In the composite coding scheme (see Theorem 6.2 and Remark 6.7), it suffices to consider the collection of all supersets of the natural decoding sets instead of considering the collection of all valid decoding set tuples. This reduces the complexity of computing the composite coding (inner) bound, specially for problems for which the sizes of the

## 6.9 Recursive Codes

In this Section, we extend the fractional local partial clique covering scheme in Section 6.5 by performing local time sharing over subproblem solutions recursively.

**Theorem 6.3.** *The capacity region  $\mathcal{C}$  of the index coding problem with side information graph  $G$  contains the rate region  $\mathcal{R}_R(G)$  that is recursively defined as the set of rate tuples  $(R_1, \dots, R_n)$  such that*

$$R_i = \sum_{J \subsetneq [n]} T_{i,J}, \quad i \in [n], \quad (6.24)$$

for some  $(T_{i,J}: i \in J)$  and  $\gamma_J, J \subsetneq [n]$ , satisfying

$$\begin{aligned} \sum_{J \subsetneq [n]: J \not\subseteq A_i} \gamma_J &\leq 1, \quad i \in [n], \\ (T_{i,J}: i \in J) &\in \gamma_J \cdot \mathcal{R}_R(G|_J), \quad J \subsetneq [n], \\ \gamma_J &\geq 0, \quad J \subsetneq [n], \\ T_{i,J} &\geq 0, \quad J \subsetneq [n], i \in J, \end{aligned} \quad (6.25)$$

where  $\mathcal{R}_R(G|_J)$  is the rate region for the subgraph  $G|_J$  and  $\mathcal{R}_R(G|_{\{i\}}) = [0, 1]$ . Here,  $a \cdot \mathcal{R} := \{aR: R \in \mathcal{R}\}$ . In particular, the broadcast rate is upper bounded by

$$\beta_R = \min_{R: (R, \dots, R) \in \mathcal{R}_R} \frac{1}{R}. \quad (6.26)$$

**Remark 6.10.** The broadcast rate  $\beta$  of an index coding problem with side information graph  $G$  is upper bounded by  $\beta'_R(G)$  which is recursively defined as the solution to the linear program

$$\begin{aligned} &\text{minimize} \quad \max_{i \in [n]} \sum_{J \subsetneq [n]: J \not\subseteq A_i} \rho_J \beta'_R(G|_J) \\ &\text{subject to} \quad \sum_{J \subsetneq [n]: i \in J} \rho_J \geq 1, \quad i \in [n], \\ &\quad \rho_J \in [0, 1], \quad J \subsetneq [n], \end{aligned} \quad (6.27)$$

where  $\beta'_R(G|_J)$  is the solution for the subgraph  $G|_J$  and  $\beta'_R(G|_{\{i\}}) = 1$ ,  $i \in [n]$ .

Recursion over rate regions (Theorem 6.3) is richer than recursion over broadcast rates (Remark 6.10); See Appendix 6.C for the proof.

**Proposition 6.10.** *For the index coding problem with side information graph  $G$ , we have*

$$\beta_R \leq \beta'_R. \quad (6.28)$$

**Remark 6.11.** The recursive bound in Theorem 6.3 improves upon the fractional local partial clique covering bound [30]. The improvement can be strict as illustrated by the 5-message problem in Figure 6.10.

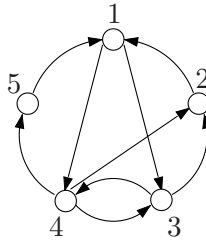
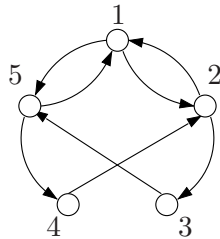

**Figure 6.10:** An index coding problem with  $\beta'_R = 3 < \beta_{\text{FLP}} = 7/2$ . Here the bounds are computed by solving the respective linear programs.

**Remark 6.12.** The tightest inner bound on the capacity region of the index coding problem achieved by local time sharing  $\mathcal{R}_{\text{LTS}}$  (and the associated upper bound on the broadcast rate  $\beta_{\text{LTS}}$ ) is obtained by using the capacity region  $\mathcal{C}(G|_J)$  of the subgraph  $G|_J$  instead of  $\mathcal{R}_R(G|_J)$  in (6.24). However, as illustrated by the 5-message example in Figure 6.11, even local time sharing over the capacity regions of subproblems is not optimal in general, demonstrating a fundamental limitation of the concept of local time sharing.

Figure 6.12 demonstrates the coding schemes that we discussed in this section and their relationship.





**Figure 6.11:** An index coding problem with  $\beta = 3 < \beta(\mathcal{R}_{\text{LTS}}) = \beta_{\text{LTS}} = 7/2$ . Here  $\beta$  is achieved by composite coding.

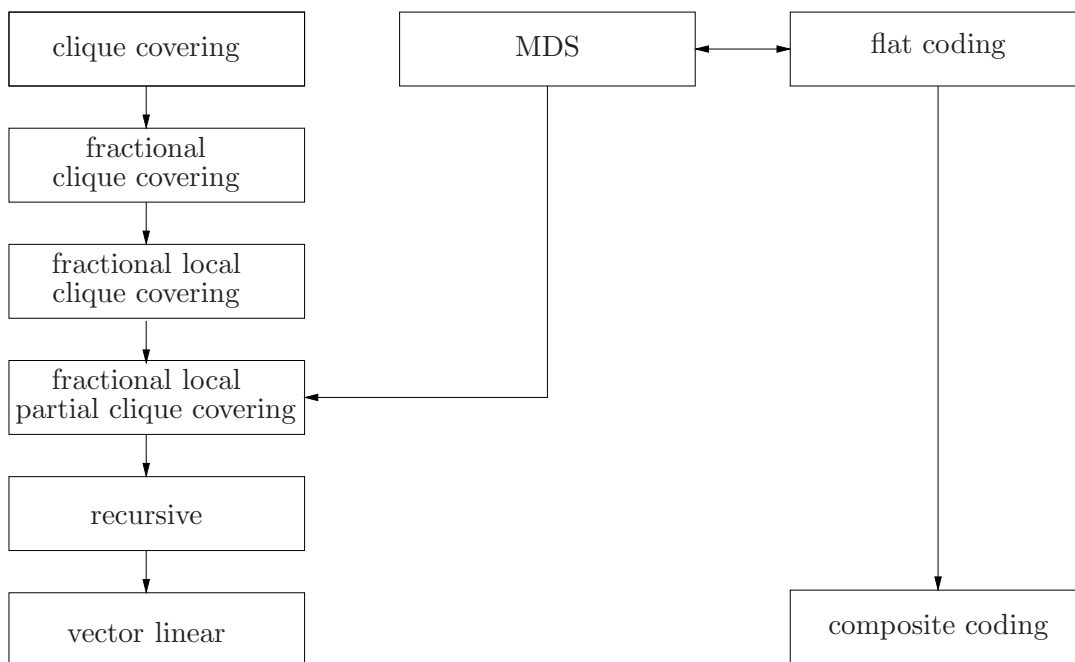

**Figure 6.12:** A summary of the coding schemes.

Chapter 6, in part, is a reprint of the material in the papers: Fatemeh Arbabjolfaei, Bernd Bandemer, Young-Han Kim, Eren Sasoglu, Lele Wang, “On the capacity region for index coding”, *Proceedings of the IEEE International Symposium on Information Theory*, Istanbul, Turkey, July 2013; and Fatemeh Arbabjolfaei, Bernd Bandemer, Young-Han Kim, “Index coding via random coding”, *Proceedings of the Iran Workshop on Communication and Information Theory*, Tehran, Iran, May 2014; and Fatemeh Arbabjolfaei and Young-Han Kim, “Local time sharing for index coding”, *Proceedings of the IEEE International Symposium*

on *Information Theory*, Honolulu, HI, USA, July 2014; and Fatemeh Arbabjolfaei and Young-Han Kim, “Elements of index coding”, to be submitted to *Foundations and Trends in Communications and Information Theory*. The dissertation author was the primary investigator and author of these papers.

## 6.A Proof of Proposition 6.8

Following the standard steps in random coding proofs in information theory [67, 57], we prove the theorem by describing a randomly generated code ensemble and showing that the average probability of error of the random code ensemble tends to zero as  $r \rightarrow \infty$ , provided that the rate tuple  $(R_1, \dots, R_n)$  satisfies (6.14). Let  $r > 0$ ,  $t_i = \lceil rR_i \rceil$ ,  $i \in [n]$ , and  $s_J = \lceil rS_J \rceil$ ,  $J \subseteq [n]$ .

**Codebook generation.** For each  $J \subseteq [n]$ , generate  $w_J(x(J))$  uniformly at random from  $[2^{s_J}]$ .

**Encoding.** To communicate message tuple  $(x_1, \dots, x_n)$ , encoder  $J \subseteq [n]$  transmits  $w_J = w_J(x(J))$ .

**Decoding.** The receiver finds the unique  $\hat{x}(D)$  such that  $w_J = w_J(\hat{x}(D), x(A))$  for every  $J \subseteq D \cup A$ . If there is more than one such tuple, then it declares an error.

**Analysis of the probability of error.** We partition the error event according to the nonempty subset  $K \subseteq D$  of erroneous message indices, i.e.,  $\hat{x}_i \neq x_i$  iff  $i \in K$ .

Therefore,

$$\begin{aligned}
P_e &= \mathbb{P}\{w_J(\hat{x}(J)) = w_J \text{ for all } J \subseteq D \cup A \text{ for some } \hat{x}(D) \neq x(D)\} \\
&= \sum_{K \subseteq D} \sum_{\substack{\hat{\mathbf{x}}: \hat{x}_i \neq x_i, i \in K \\ \hat{x}_i = x_i, i \notin K}} \mathbb{P}\left(\bigcap_{\substack{J \subseteq D \cup A \\ J \cap K \neq \emptyset}} \{w_J(\hat{x}(J)) = w_J\}\right) \\
&\leq \sum_{K \subseteq D} 2^{\sum_{i \in K} t_i - \sum_{J \subseteq D \cup A: J \cap K \neq \emptyset} s_J} \tag{6.29} \\
&\leq \sum_{K \subseteq D} 2^{\sum_{i \in K} r R_i + 1 - \sum_{J \subseteq D \cup A: J \cap K \neq \emptyset} r S_J},
\end{aligned}$$

where (6.29) holds since for each  $K$  the number of erroneous tuples is  $2^{\sum_{i \in K} t_i} - 1$ , and for each erroneous tuple with  $\hat{x}_i \neq x_i$  iff  $i \in K$ , the probability that two distinct message tuples are mapped to the same  $w_J$  for all  $J \subseteq D \cup A$  with  $J \cap K \neq \emptyset$  is  $2^{-\sum s_J}$ . Thus, the error probability  $P_e$  tends to zero as  $r \rightarrow \infty$ , provided that

$$\sum_{i \in K} R_i < \sum_{J \subseteq D \cup A: J \cap K \neq \emptyset} S_J$$

for all  $K \subseteq D$ .

## 6.B Proof of Proposition 6.9

The proposition is proved by applying the following lemma at most  $n$  times.

**Lemma 6.1.** *Let  $(D_1, \dots, D_n)$  be a tuple of decoding sets such that  $N_i \setminus D_i \neq \emptyset$  for some  $i \in [n]$ . Then  $\mathcal{R}(D_1, \dots, D_n) \subseteq \mathcal{R}(D'_1, \dots, D'_n)$  for some  $(D'_1, \dots, D'_n)$  satisfying*

$$N_i \subseteq D'_i \quad \text{and} \quad D'_k = D_k, \forall k \neq i.$$

*Proof of the Lemma:* Let  $N_i \setminus D_i = \{i_1, \dots, i_m\}$ . Assume that  $i_1, \dots, i_m$  are added to  $N_i$  using Algorithm 1 in order. Therefore, we have

$$A_{i_k} \subseteq A_i \cup D_i \cup \{i_1, \dots, i_{k-1}\} \subseteq A_i \cup D_i \cup D_{i_1} \cup \dots \cup D_{i_{k-1}}, \quad k \in [m]. \quad (6.30)$$

Define  $(D'_1, \dots, D'_n)$  by

$$D'_k = \begin{cases} D_k & k \neq j \\ D_i \cup D_{i_1} \cup \dots \cup D_{i_m} & k = i. \end{cases}$$

Since  $i_k \in D_{i_k}$ ,  $k \in [m]$ , we have  $N_i \subseteq D'_i = D_i \cup D_{i_1} \cup \dots \cup D_{i_m}$  and thus it suffices to prove the following claim.

Claim:  $\mathcal{R}(D_1, \dots, D_n) \subseteq \mathcal{R}(D'_1, \dots, D'_n)$ .

*Proof of the claim:* Let  $(R_1, \dots, R_n) \in \mathcal{R}(D_1, \dots, D_n)$ , i.e., there exists  $(S_J, J \subseteq [n])$  such that (6.13) and (6.15) are satisfied. For  $k \neq i$  the inequalities in (6.15) are the same for  $\mathcal{R}(D_1, \dots, D_n)$  and  $\mathcal{R}(D'_1, \dots, D'_n)$ . Therefore, it suffices to show that  $(R_1, \dots, R_n)$  together with  $(S_J, J \subseteq [n])$  satisfy the following.

$$\sum_{k \in L'} R_k \leq \sum_{J \subseteq A_i \cup D'_i: J \cap L' \neq \emptyset} S_J, \quad \forall L' \subseteq D'_i \setminus A_i. \quad (6.31)$$

Consider the following partition of  $L'$ .

$$L' = L \cup L_1 \cup \dots \cup L_m,$$

where

$$\begin{aligned}
L &\subseteq D_i \setminus A_i, \\
L_1 &\subseteq D_{i_1} \setminus (A_i \cup D_i), \\
L_2 &\subseteq D_{i_2} \setminus (A_i \cup D_i \cup D_{i_1}), \\
&\vdots \\
L_m &\subseteq D_{i_m} \setminus (A_i \cup D_i \cup D_{i_1} \cup \dots \cup D_{i_{m-1}}).
\end{aligned}$$

So the LHS of (6.31) is

$$\sum_{k \in L'} R_k = \sum_{k \in L} R_k + \sum_{k \in L_1} R_k + \dots + \sum_{k \in L_m} R_k.$$

By (6.30) we have

$$L_k \subseteq D_{i_k} \setminus A_{i_k}, \quad k \in [m].$$

Hence, by (6.15),

$$\sum_{k \in L} R_k \leq \sum_{J \subseteq A_i \cup D_i : J \cap L \neq \emptyset} S_J, \tag{6.32}$$

and for  $k \in [m]$

$$\begin{aligned}
\sum_{i \in L_k} R_i &\leq \sum_{J \subseteq A_{i_k} \cup D_{i_k} : J \cap L_k \neq \emptyset} S_J \\
&\leq \sum_{J \subseteq A_i \cup D_i \cup D_{i_1} \cup \dots \cup D_{i_{k-1}} \cup D_{i_k} : J \cap L_k \neq \emptyset} S_J \\
&= \sum_{J \subseteq A_i \cup D_i \cup D_{i_1} \cup \dots \cup D_{i_{k-1}} \cup D_{i_k} : J \not\subseteq A_i \cup D_i \cup D_{i_1} \cup \dots \cup D_{i_{k-1}}, J \cap L_k \neq \emptyset} S_J.
\end{aligned} \tag{6.33}$$

Summing up the RHS of (6.32) and (6.33) for  $k \in [m]$  yields (6.31).

## 6.C Proof of Proposition 6.10

We use induction on the number  $n$  of messages. The induction base is trivially true. Assume that (6.28) holds for all index coding problems with  $n - 1$  or less messages. Let  $(\rho_J, J \subsetneq [n])$  be a feasible solution to (6.27) such that

$$\beta_{\mathbf{R}}(G) = \max_{i \in [n]} \sum_{J \subsetneq [n]: J \not\ni A_i} \rho_J \beta_{\mathbf{R}}(G|_J).$$

For all  $J \subsetneq [n]$ , define

$$\gamma_J = \frac{\rho_J \beta_{\mathbf{R}}(G|_J)}{\beta_{\mathbf{R}}(G)},$$

$$T_{i,J} = \begin{cases} \frac{\rho_J}{\beta_{\mathbf{R}}(G)} & i \in J, \\ 0 & \text{otherwise.} \end{cases}$$

Then, for all  $i \in [n]$  we have

$$\sum_{J \subsetneq [n]: J \not\ni A_i} \gamma_J = \sum_{J \subsetneq [n]: J \not\ni A_i} \frac{\rho_J \beta_{\mathbf{R}}(G|_J)}{\beta_{\mathbf{R}}(G)} \leq 1, \quad (6.34)$$

$$R_i = \sum_{J \subsetneq [n]} T_{i,J} = \sum_{J \subsetneq [n]: i \in J} \frac{\rho_J}{\beta_{\mathbf{R}}(G)} \geq \frac{1}{\beta_{\mathbf{R}}(G)}. \quad (6.35)$$

In addition, since  $(1/\beta_{\mathbf{R}}(G|_J), \dots, 1/\beta_{\mathbf{R}}(G|_J)) \in \mathcal{R}_{\mathbf{R}}(G|_J)$  and  $\gamma_J/\beta_{\mathbf{R}}(G|_J) = \rho_J/\beta_{\mathbf{R}}(G)$ , by the induction hypothesis, we have  $(T_{i,J}: i \in J) \in \gamma_J \cdot \mathcal{R}_{\mathbf{R}}(G|_J)$ , which completes the proof.

# Chapter 7

## Criticality

Let  $e$  be an edge of side information graph  $G = (V, E)$ . We denote the graph resulting from removing  $e$  from  $G$  by  $G_e$ , i.e.,

$$V(G_e) = V(G) \text{ and } E(G_e) = E(G) \setminus \{e\}.$$

Given the index coding problem  $G$ , the edge  $e \in E$  is said to be *critical* if  $\mathcal{C}(G_e) \neq \mathcal{C}(G)$ , or in other words, if the removal of  $e$  from  $G$  strictly reduces the capacity region. The index coding problem  $G$  itself is said to be *critical* if every  $e \in E(G)$  is critical. Thus, each critical graph (= index coding problem) cannot be made “simpler” into another one of the same capacity region.

The notion of criticality was first introduced by Tahmasbi, Shahrabi, and Gohari [70], In this Section, we present sufficient and necessary conditions for criticality of an index coding problem.

## 7.1 A Sufficient Condition

A *Hamiltonian cycle* in a graph is a cycle, if any, that visits each vertex exactly once. Given a graph  $G = (V, E)$ , the vertex induced subgraph  $G|_J$  is referred to as a *unicycle* if its set of edges is a Hamiltonian cycle in  $G|_J$ . As an example, in Figure 7.1(a),  $G|_{\{1,2,3\}}$  is a unicycle, but  $G$  itself is not a unicycle. As another example, for the graph in Figure 7.1(b),  $G|_{\{1,2,3\}}$  and  $G|_{\{1,3,4\}}$  are both unicyles. Note that if the subgraph  $G|_J$  is a unicycle, then  $G|_{J'}$  cannot be a unicycle for any  $J'$  that is a proper subset or superset of  $J$ .

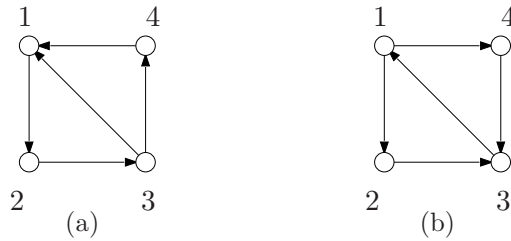

**Figure 7.1:** (a)  $G|_{\{1,2,3\}}$  is a unicycle, but  $G$  is not a unicycle. (b)  $G|_{\{1,2,3\}}$  and  $G|_{\{1,3,4\}}$  are both unicyles.

Let  $e$  be an edge of  $G|_J$ , where  $J \subseteq V$  and  $G|_J$  is a unicycle. The rate tuple  $(R_1, \dots, R_n)$  such that

$$R_i = \begin{cases} \frac{1}{|J|-1}, & i \in J, \\ 0, & i \notin J, \end{cases} \quad (7.1)$$

is achievable for index coding problem  $G$ , for example, using an MDS code over  $J$ . The vertex-induced subgraph  $G_e|_J$ , however, is acyclic (since the Hamiltonian cycle in  $G|_J$  is broken and by definition there is no other cycle). Therefore, by the MAIS outer bound in Remark 5.1, any rate tuple  $(R'_1, \dots, R'_n) \in \mathcal{C}(G_e)$  must



satisfy

$$\sum_{i \in J} R'_i \leq 1. \quad (7.2)$$

The rate tuple in (7.1), however, does not satisfy (7.2) and thus is not in  $\mathcal{C}(G_e)$ . This implies that removing edge  $e$  from  $G$  strictly reduces the capacity region ( $\mathcal{C}(G_e) \neq \mathcal{C}(G)$ ), establishing the following sufficient condition for the criticality of a problem.

**Theorem 7.1** (Union-of-unicycles condition). *If every edge of  $G$  belongs to a vertex induced subgraph that is a unicycle, then  $G$  is critical.*

**Example 7.1.** Consider the index coding problem  $G$  with side information graph depicted in Figure 7.1(b). Since every edge of  $G$  belongs to a unicycle, by Theorem 7.1,  $G$  is critical.

The union-of-unicycles condition, however, is not necessary for criticality of a graph, as illustrated by the following.

**Example 7.2.** The capacity region of the index coding problem with side information graph shown in Figure 7.2 is characterized by

$$R_1 + R_2 \leq 1,$$

$$R_1 + R_3 \leq 1,$$

$$R_1 + R_4 \leq 1,$$

$$R_2 + R_4 \leq 1,$$

$$R_2 + R_5 \leq 1,$$

$$R_3 + R_5 \leq 1,$$

which is achievable by the composite coding scheme (Theorem 6.2). Although the edge  $2 \rightarrow 5$  does not belong to any unicycle, removing it from the side information graph reduces the capacity region to

$$\begin{aligned}
 R_1 + R_2 &\leq 1, \\
 R_1 + R_3 &\leq 1, \\
 R_1 + R_4 &\leq 1, \\
 R_2 + R_4 &\leq 1, \\
 R_2 + R_5 &\leq 1, \\
 R_3 + R_5 &\leq 1, \\
 R_1 + R_2 + R_3 + R_4 + R_5 &\leq 2,
 \end{aligned} \tag{7.3}$$

which is also achievable by the composite coding scheme.

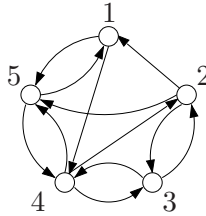

**Figure 7.2:** A critical 5-message index coding problem. Although the edge  $2 \rightarrow 5$  does not belong to any unicycle, it is critical. The capacity region is achieved by composite coding with or without the edge  $2 \rightarrow 5$ .

**Remark 7.1.** The union-of-unicycles condition captures “criticality” with respect to the MAIS outer bound, that is, edge  $e$  belongs to a unicycle iff  $\mathcal{R}_{\text{MAIS}}(G_e) \subsetneq \mathcal{R}_{\text{MAIS}}(G)$ . If  $\mathcal{R}_{\text{MAIS}}(G_e) \subsetneq \mathcal{R}_{\text{MAIS}}(G)$ , then there exists a subset  $J \subseteq V$  such that  $G|_J$  contains a cycle and  $G_e|_J$  is acyclic. Let  $J_{\min}$  be a minimal such subset. Then,  $G|_{J_{\min}}$  is a unicycle that contains  $e$ . Conversely, let  $G|_J$ ,  $J \subseteq V$ , be a unicycle that contains  $e$ . By the definition of unicycle,  $G_e|_J$  is acyclic. Therefore, by the MAIS

outer bound, any rate tuple  $(R_1, \dots, R_n) \in \mathcal{C}(G_e)$  must satisfy

$$\sum_{i \in J} R_i \leq 1. \quad (7.4)$$

However, since  $G|_J$  is not acyclic, (7.4) is not an inequality of  $\mathcal{R}_{\text{MAIS}}(G)$ .

## 7.2 Necessary Conditions

Tahmasbi, Shahrabi, and Gohari established the following necessary condition.

**Proposition 7.1** (Union-of-cycles condition [70]). *If  $G$  is critical, then every edge belongs to a directed cycle.*

The necessary condition in Proposition 7.1 can be viewed as a direct application of Remark 4.1 which implies that every edge that lies on a directed cut can be removed without affecting the capacity region. Therefore, if  $G$  is critical, then by Farkas Lemma [71, Th. 2.2] (that is, each edge in a directed graph either lies on a directed cycle or belongs to a directed cut but not both), every edge belongs to a directed cycle.

Side information sets  $A_1, \dots, A_n$  of an index coding problem  $G$  are said to be *degraded* if there exist  $i, j \in V(G)$  such that  $j \in A_i$  and  $A_j \subseteq A_i$ . In this case, the edge  $j \rightarrow i$  can be removed since  $x_j$  can be recovered at node  $i$ . This observation leads to the following necessary condition.

**Proposition 7.2** (Nondegradedness condition). *If  $G$  is critical, then side information sets must be nondegraded.*

Next, we present another necessary condition by establishing a partial converse to Theorem 7.1. Suppose  $G$  is critical. Then, for every  $e \in E(G)$  we have

$\mathcal{C}(G_e) \subsetneq \mathcal{C}(G)$ . If the MAIS bound is tight for  $G_e$ ,

$$\mathcal{R}_{\text{MAIS}}(G_e) = \mathcal{C}(G_e) \subsetneq \mathcal{C}(G) \subseteq \mathcal{R}_{\text{MAIS}}(G).$$

Thus, as discussed in Remark 7.1, the edge  $e$  belongs to a unicycle. This implies the following partial converse to Theorem 7.1.

**Proposition 7.3.** *If  $G = (V, E)$  is critical, then*

- *every edge  $e \in E$  belongs to a unicycle, or*
- *the MAIS bound is not tight for  $G_e$ , i.e.,  $\mathcal{R}_{\text{MAIS}}(G_e) \neq \mathcal{C}(G_e)$ , for every  $e \in E$  that does not belong to any unicycle.*

In other words, edge  $e$  is not critical if it does not belong to any unicycle and the MAIS bound is tight for  $G_e$ . Recall that the edge  $2 \rightarrow 5$  in Figure 7.2 is critical and does not belong to any unicycle. As is suggested by Proposition 7.3 and verified by (7.3), the MAIS bound is not tight for the side information graph resulting from removing this edge.

The following summarizes all the necessary conditions for the criticality of a problem that we know so far.

**Theorem 7.2.** *If  $G = (V, E)$  is critical, then*

1. *every edge belongs to a directed cycle, and*
2. *side information sets are nondegraded, and*
3. *for every edge  $e \in E$  either  $e$  belongs to a unicycle, or the MAIS bound is not tight for  $G_e$ , i.e.,  $\mathcal{R}_{\text{MAIS}}(G_e) \neq \mathcal{C}(G_e)$ .*

The next three examples demonstrate that these necessary conditions are mutually independent.

**Example 7.3.** The six-message problem

$$(1|5, 6), (2|6), (3|6), (4|6), (5|1), (6|2, 3, 4, 5)$$

satisfies the union-of-cycles and nondegradedness conditions. However, it does not satisfy the necessary condition in Proposition 7.3, as the edge  $5 \rightarrow 6$  does not belong to any unicycle and the MAIS bound is tight (and is achieved by the composite coding scheme) after removing this edge.

**Example 7.4.** The six-message problem

$$(1|4, 5), (2|5, 6), (3|5), (4|1, 6), (5|1, 2), (6|2, 3, 4, 5)$$

satisfies the union-of-cycles condition and the necessary condition in Proposition 7.3. However,  $A_3 \subset A_6$  and thus it does not satisfy the nondegradedness condition.

**Example 7.5.** The six-message problem

$$(1|4, 6), (2|5, 6), (3|5), (4|1, 6), (5|1, 2), (6|2, 4, 5)$$

satisfies the nondegradedness condition and the necessary condition in Proposition 7.3. However, the edge  $5 \rightarrow 3$  does not belong to any cycle and thus the problem does not satisfy the union-of-cycles condition.

Satisfying all the necessary conditions in Theorem 7.2 at the same time, however, is still not sufficient for criticality, as illustrated by the following.

**Example 7.6.** The side information graph  $G$  shown in Figure 7.3 satisfies union-of-cycles and nondegradedness conditions. The edge  $4 \rightarrow 1$  is the only edge that does not belong to a unicycle and the MAIS bound is not tight for the index

coding problem with side information graph resulting from removing this edge (see Example 5.2). Therefore,  $G$  satisfies the necessary condition in Proposition 7.3 as well. However, index coding problem  $G$  is not critical as the capacity region is characterized by

$$R_1 + R_3 \leq 1,$$

$$R_1 + R_4 \leq 1,$$

$$R_2 + R_4 \leq 1,$$

$$R_2 + R_5 \leq 1,$$

$$R_3 + R_5 \leq 1,$$

$$R_1 + R_2 + R_3 + R_4 + R_5 \leq 2,$$

with or without the edge  $4 \rightarrow 1$ .

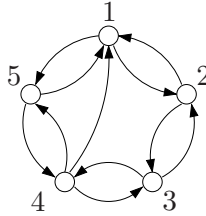

**Figure 7.3:** A 5-message noncritical index coding problem that satisfies all the three necessary conditions in Theorem 7.2. The capacity region is the same with or without the edge  $4 \rightarrow 1$  and is achieved by the composite coding scheme.

**Remark 7.2.** If a graph satisfies the union-of-unicycles condition, it trivially satisfies the union-of-cycles condition and the necessary condition in Proposition 7.3. We now argue that, as expected, satisfying the union-of-unicycles condition also implies the nondegradedness condition. Assume that  $G$  has degraded side information sets. Then, there exists an edge  $j \rightarrow i$  such that  $A_j \subseteq A_i$ . We show that this edge cannot belong to a unicycle. If the edge  $j \rightarrow i$  does not belong to any cycle,

then trivially it does not belong to any unicycle. Otherwise, it suffices to show that none of the cycles that contain this edge is a unicycle. Assume that  $j \rightarrow i$  lies on a cycle  $C = (j, i, \dots, v)$ , which by degradedness must have at least three vertices. Then, by definition,  $v \in A_j$  and, by the assumption,  $v \in A_i$ . Therefore,  $(i, \dots, v)$  is also a cycle and  $C$  is not a unicycle.

### 7.3 Application

In this section, we use the results of the previous sections to relate the capacity of index coding problem  $G$  and its MAIS bound to those of simpler problems. Consider the graph  $G = (V, E)$  and let  $G'$  be the graph resulting from removing all edges of  $G$  that do not belong to any unicycle, i.e.,

$$\begin{aligned} V(G') &= V(G), \\ E(G') &= \{e \in E(G) : e \text{ in a unicycle of } G\}. \end{aligned} \tag{7.5}$$

**Proposition 7.4.**  $\mathcal{R}_{\text{MAIS}}(G') = \mathcal{R}_{\text{MAIS}}(G)$ .

In words, the set of edges of  $G$  that do not belong to any unicycle, is the (maximum) set of edges that can be removed from  $G$  without changing the MAIS bound. The proof of the proposition, which is implied by Remark 7.1, is presented in Appendix 7.A.

This observation leads to a condition under which the capacity of index coding problem  $G$  is equal to the capacity of the simpler problem  $G'$ . If the MAIS bound is tight for  $G'$ , then

$$\mathcal{R}_{\text{MAIS}}(G') = \mathcal{C}(G') \subseteq \mathcal{C}(G) \subseteq \mathcal{R}_{\text{MAIS}}(G),$$

and thus, Proposition 7.4 implies the following.

**Proposition 7.5.** *If the MAIS bound is tight for  $G'$ , then*

$$\mathcal{R}_{\text{MAIS}}(G') = \mathcal{C}(G') = \mathcal{C}(G) = \mathcal{R}_{\text{MAIS}}(G).$$

Consequently, if the MAIS bound is tight for  $G'$ , then  $G$  is not critical and all the edges that do not belong to any unicycle can be removed without reducing the capacity.

**Remark 7.3.** It can be similarly shown that the result of Proposition 7.5 also holds for the broadcast rate. If  $\beta_{\text{MAIS}}(G') = \beta(G')$ , then  $\beta_{\text{MAIS}}(G) = \beta(G) = \beta(G') = \beta_{\text{MAIS}}(G')$ .

**Example 7.7.** Consider the side information graph  $G$  shown in Fig. 7.4, where edges  $5 \rightarrow 3$ ,  $3 \rightarrow 1$ , and  $6 \rightarrow 5$  do not belong to any unicycle. It can be shown that the capacity region for problem  $G'$  is achieved by composite coding [27] and is characterized by

$$\begin{aligned} R_1 + R_3 + R_4 &\leq 1, \\ R_1 + R_3 + R_5 &\leq 1, \\ R_2 + R_3 + R_4 + R_6 &\leq 1, \\ R_2 + R_3 + R_5 + R_6 &\leq 1, \end{aligned} \tag{7.6}$$

which is equal to its MAIS bound. Thus, by Proposition 7.5,  $G$  is not critical and its capacity is also characterized by (7.6).

Note that when  $G$  is bidirectional (undirected), the polytope associated with  $G$  in (2.5) is equivalent to the MAIS outer bound in (5.1). It is also easy to



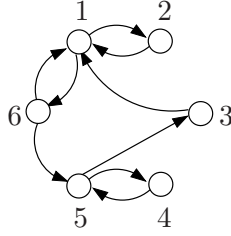

**Figure 7.4:** A noncritical 6-message index coding problem with nondegraded side information sets. The edges  $5 \rightarrow 3$ ,  $3 \rightarrow 1$ , and  $6 \rightarrow 5$  lie on a directed cycle, but do not belong to any unicycle.

see that the rate tuple given by each incidence vector of cliques in  $G$  is achievable by clique covering and thus the polytope associated with  $G$  in (2.4) is achievable by fractional clique covering (see Section 6.3). Therefore, by Lemma 2.3, if  $G$  is bidirectional and perfect, then the capacity region is equal to the MAIS outer bound in (5.1), which is achieved by fractional clique covering [20]. This together with Proposition 7.5, implies the following.

**Proposition 7.6.** *If  $G'$  is bidirectional and  $U(G')$  is perfect, then  $\mathcal{C}(G) = \mathcal{R}_{\text{MAIS}}(G)$  which is achieved by the fractional clique covering scheme.*

This result can be recast to an earlier result by Yi, Sun, Jafar, and Gesbert [20], using the following two lemmas that are proved in Appendices 7.B and 7.C.

**Lemma 7.1.** *Consider  $G = (V, E)$  and let  $G'$  be the graph as defined in (7.5). The following statements are equivalent.*

- (1) *For each clique  $K$  in  $U(\bar{G})$ ,  $G|_K$  is acyclic.*
- (2) *For each  $S \subseteq V(G)$ , if  $G|_S$  contains a cycle, then there exists a bidirectional edge in  $G|_S$ , i.e.,  $\exists i, j \in S$  such that  $(i, j) \in E(G)$  and  $(j, i) \in E(G)$ .*
- (3) *No unidirectional edge of  $G$  belongs to a unicycle.*
- (4)  *$G'$  is bidirectional.*

**Lemma 7.2.** *If  $G'$  is bidirectional, then  $\overline{U(G')} = U(\bar{G})$ .*

By Lemma 2.3 ( $U$  is perfect iff  $\bar{U}$  is perfect), Lemma 7.1, and Lemma 7.2, we can now restate Proposition 7.6 as follows.

**Proposition 7.7** (Yi, Sun, Jafar, and Gesbert [20]). *If  $U(\bar{G})$  is perfect and for each clique  $K$  in  $U(\bar{G})$ ,  $G|_K$  is acyclic, then  $\mathcal{C}(G) = \mathcal{R}_{\text{MAIS}}(G)$  which is achieved by the fractional clique covering scheme.*

Chapter 7, in full, is a reprint of the material in the papers: Fatemeh Arbabjolfaei and Young-Han Kim, “On critical index coding problems”, *Proceedings of the IEEE Information Theory Workshop*, Jeju Island, Korea, Oct. 2015; and Fatemeh Arbabjolfaei and Young-Han Kim, “Elements of index coding”, to be submitted to *Foundations and Trends in Communications and Information Theory*. The dissertation author was the primary investigator and author of these papers.

## 7.A Proof of Proposition 7.4

Remark 7.1, together with the following, implies Proposition 7.4.

**Lemma 7.3.** *If  $e_1$  and  $e_2$  do not belong to any unicycle of  $G$ , then  $e_2$  does not belong to any unicycle of  $G_{e_1}$ .*

*Proof:* If  $e_2$  does not belong to any cycle of  $G$ , then it trivially does not belong to any unicycle of  $G_{e_1}$ . Suppose  $e_2$  belongs to some cycle in  $G$ . It suffices to show that for every cycle  $C$  of  $G$  that contains  $e_2$ ,  $C \setminus e_1$  is not a unicycle of  $G_{e_1}$ . Let  $e_1 = (u_1, u_2)$ ,  $e_2 = (v_l, v_1)$ , and  $C = (v_1, \dots, v_l)$  be a cycle of  $G$  that contains  $e_2$ . By the assumption,  $C$  is not a unicycle and thus  $l \geq 3$ . If  $|\{u_1, u_2\} \cap \{v_1, \dots, v_l\}| < 2$ , then removing  $e_1$  does not affect  $C$  and hence  $C \setminus e_1$  is not a unicycle of  $G_{e_1}$ . Suppose  $|\{u_1, u_2\} \cap \{v_1, \dots, v_l\}| = 2$  and consider three cases.

Case 1:  $e_1 = (v_i, v_{i+1})$  for some  $i \in [l - 1]$ . In this case, removing  $e_1$  breaks

the cycle  $C$  and hence  $C \setminus e_1$  is not a unicycle of  $G_{e_1}$ .

Case 2:  $e_1 = (v_i, v_j)$  for some  $1 \leq i < j \leq l$ ,  $(i, j) \neq (1, l)$ . In this case,  $(v_1, \dots, v_i, v_j, \dots, v_l)$  is a cycle of  $G$  that contains both  $e_1$  and  $e_2$  and thus, by the assumption, is not a unicycle and has a chord, which is also a chord of  $C \setminus e_1$ . Thus,  $C \setminus e_1$  is not a unicycle of  $G_{e_1}$ .

Case 3:  $e_1 = (v_j, v_i)$  for some  $1 \leq i < j \leq l$ ,  $(i, j) \neq (1, l)$ . In this case,  $(v_i, \dots, v_j)$  is a cycle of  $G$  that contains  $e_1$  and thus, by the assumption, is not a unicycle and has a chord, which is also a chord of  $C \setminus e_1$ . Thus,  $C \setminus e_1$  is not a unicycle of  $G_{e_1}$ .

□

## 7.B Proof of Lemma 7.1

(1)  $\Rightarrow$  (2): Assume that (2) does not hold. Then there exists a subset  $S$  such that  $G|_S$  contains a cycle but does not have any bidirectional edge. By the definition of  $U(\bar{G})$ ,  $S$  is a clique of  $U(\bar{G})$ , which contradicts (1).

(2)  $\Rightarrow$  (1): Assume that (1) does not hold. Then there exists a clique  $K$  in  $U(\bar{G})$  such that  $G|_K$  has a cycle. By the definition of  $U(\bar{G})$ ,  $G|_K$  has no bidirectional edge, which contradicts (2).

(2)  $\Rightarrow$  (3): Assume that there exists a unidirectional edge  $e$  and  $S \subseteq V$ ,  $|S| \geq 3$ , such that  $G|_S$  is a unicycle and  $e \in E(G|_S)$ . By the definition of unicycle, all of the edges of  $G|_S$  are unidirectional, which contradicts (2).

(3)  $\Rightarrow$  (2): Assume that (2) does not hold. Then there exists a subset  $S$ ,  $|S| \geq 3$  such that  $G|_S$  has a cycle but does not have any bidirectional edge. A minimal such  $S$  forms a unicycle and hence all of its unidirectional edges belong to a unicycle, which contradicts (3).

(3)  $\Rightarrow$  (4): To form  $G'$ , every edge of  $G$  that do not belong to a unicycle is removed. Hence, if (3) holds, then all unidirectional edges of  $G$  are removed to form bidirectional  $G'$ .

(4)  $\Rightarrow$  (3):  $G'$  is formed by removing edges of  $G$  that do not belong to any unicycle. Hence,  $G'$  is bidirectional implies that no unidirectional edge of  $G$  belongs to a unicycle.

## 7.C Proof of Lemma 7.2

Since  $G'$  is bidirectional and every bidirectional edge belongs to a unicycle, we have

$$\{i, j\} \in E(U(G')) \iff (i, j) \in E(G) \text{ and } (j, i) \in E(G).$$

By definition,

$$\{i, j\} \notin E(U(\bar{G})) \iff (i, j) \in E(G) \text{ and } (j, i) \in E(G).$$

Thus,  $\overline{U(G')} = U(\bar{G})$ .

## Chapter 8

# Index Coding Capacity For Small Problems

The composite coding scheme matches the polymatroidal bound for all 9,608 index coding problems with up to five messages [27]. In [72] it is shown that linear codes are optimal for all index coding instances with five or fewer messages. The number of instances of the index coding problem with  $n$  messages, which is equal to the number of nonisomorphic directed graphs with  $n$  vertices [2, Seq. A000273], blows up quickly with  $n$ . Even when  $n$  is as small as six, there are 1,540,944 nonisomorphic instances. In this section, we utilize the criticality conditions and the structural properties discussed earlier to identify the 6-message index coding instances for which the capacity can be characterized via the capacities of “simpler” problems. By Theorem 4.1, if  $G$  can be decomposed into smaller graphs, then the capacity of  $G$  can be expressed as a simple function of the capacities of smaller problems with five or fewer messages, for which the capacity is known [27]. At the same time, by Propositions 7.1, 7.2, and 7.3 (see also Theorem 7.2), if the graph  $G$  does not satisfy the three necessary conditions, then a violating edge  $e$  can be

removed to form a new graph  $G_e$  of the same capacity (which may or may not be known as  $G_e$  still has 6 vertices).

Among the above conditions for simplification, we focus on the following four properties on  $G$ . If any of them is satisfied, then  $G$  can be simplified.

$P_1$ :  $G$  is not strongly connected.

$P_2$ : The complement of  $G$  is disconnected.

$P_3$ :  $G$  is not a union-of-unicycles ( $G \neq G'$ ) and the MAIS bound is tight for  $G'$ .

$P_4$ :  $G$  has degraded side information subsets.

Note that if the complement of  $G$  is disconnected, then  $G$  is strongly connected. Hence,  $P_1$  and  $P_2$  are mutually exclusive. The properties  $P_1$  and  $P_2$  allow decomposition into smaller problems, while  $P_1$ ,  $P_3$ , and  $P_4$  allow removal of some edge. Finally,  $P_1$ ,  $P_2$ , and  $P_3$  (for the case of  $n = 6$ ) lead to simpler problems with known capacity, while  $P_4$  may result in a simpler problem with still unknown capacity.

Table 8.1 shows the number of 6-message instances that satisfy each of the mentioned properties.

**Table 8.1:** The number of 6-message index coding instances that satisfy properties  $P_1$ - $P_4$ .

Structural Property	Number of six-message instances
$P_1$	493,936
$P_2$	10,101
$P_3$	$\geq 1,513,890$
$P_4$	1,336,566
$\neg(P_1 \vee P_2 \vee P_3 \vee P_4)$	$\leq 10,634$

It can be easily checked that the side information graphs corresponding to the six-message instances in Examples 7.3 to 7.5 have connected complement and

thus do not satisfy property  $P_2$ . This proves that there are instances satisfying  $(P_1 \wedge \neg P_2 \wedge \neg P_3 \wedge \neg P_4)$  or  $(P_3 \wedge \neg P_1 \wedge \neg P_2 \wedge \neg P_4)$ , or  $(P_4 \wedge \neg P_1 \wedge \neg P_2 \wedge \neg P_3)$ . Moreover, the six-message problem

$$(1|6), (2|6), (3|6), (4|6), (5|6), (6|1, 2, 3, 4, 5)$$

satisfies  $P_2$  but not  $P_1$ ,  $P_3$ , or  $P_4$ . Therefore, checking all of these four properties is useful in removing instances that do not need further investigation.

For the remaining 10,634 instances that are not simplified, the polymatroidal bound in Theorem 5.1 is achieved by either composite coding or a scalar linear code on  $\mathbb{F}_2$ . Therefore, the capacities of all 1,540,944 index coding instances with 6 messages are established.

Chapter 8, in full, is a reprint of the material in the paper: Fatemeh Arbabjolfaei and Young-Han Kim, “Elements of index coding”, to be submitted to *Foundations and Trends in Communications and Information Theory*. The dissertation author was the primary investigator and author of this paper.

# Chapter 9

## Approximate Capacity for Some Classes

In this Section, we first review some results in Ramsey theory which we will use in the rest of the section to approximate the broadcast rate.

### 9.1 Ramsey Numbers

Given a class  $\mathcal{G}$  of undirected graphs and two positive integers  $i$  and  $j$ , the *Ramsey number*  $R_{\mathcal{G}}(i, j)$  is defined as the smallest positive integer such that every graph in  $\mathcal{G}$  with at least  $R_{\mathcal{G}}(i, j)$  vertices has a clique of size  $i$  or an independent set of size  $j$ . If  $\mathcal{G}$  is the class of all undirected finite simple graphs, then the Ramsey number is denoted by  $R(i, j)$ . In general, determining Ramsey numbers for most classes  $\mathcal{G}$  is quite difficult, but they are easily computed for very small values of  $i$  and  $j$ .

**Lemma 9.1** (Belmonte, Heggernes, Hof, Rafiey, and Saei [73]). *For any nonempty*



graph class  $\mathcal{G}$  of undirected graphs,

$$R_{\mathcal{G}}(1, j) = R_{\mathcal{G}}(i, 1) = 1, \quad i, j \geq 1.$$

If  $\mathcal{G}$  contains all edgeless graphs, i.e., all  $U = (V, E)$  with  $E = \emptyset$ , then

$$R_{\mathcal{G}}(2, j) = j, \quad j \geq 1.$$

Similarly, if  $\mathcal{G}$  contains all complete graphs, i.e., all  $U = (V, E)$  with  $E = \{\{i, j\} : i \neq j \in V\}$ , then

$$R_{\mathcal{G}}(i, 2) = i, \quad i \geq 1.$$

The following upper bound on the Ramsey number is well-known.

**Lemma 9.2** (Erdős and Szekeres [74]). *For any  $i, j \geq 1$*

$$R(i, j) \leq \binom{i+j-2}{i-1}.$$

For some classes of graphs, this upper bound can be tightened.

A graph is said to be *planar* if it can be drawn on a plane without edges crossing each other. Figure 9.1 shows examples of a 4-node planar graph and a 5-node nonplanar graph. Note that an edgeless graph is planar. Let  $\mathcal{P}$  be the class of undirected planar graphs. The Ramsey number for this class is completely determined and is given in Table 9.1.

The *line graph* of an undirected graph  $U$  is obtained by associating a vertex with each edge of the graph  $U$  and connecting two vertices with an edge iff the corresponding edges of  $U$  have a vertex in common. Figure 9.2 shows a graph and

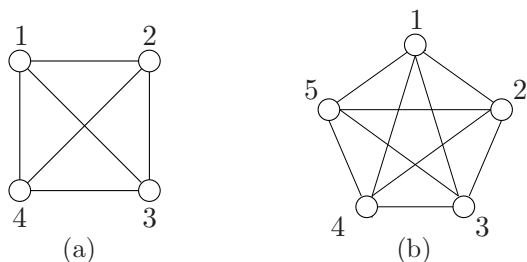
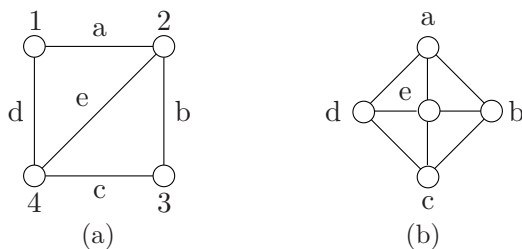

**Figure 9.1:** (a) A 4-node planar graph (the edge  $\{1, 3\}$  can be drawn such that it does not cross  $\{2, 4\}$ ). (b) A 5-node nonplanar graph.

**Table 9.1:** Ramsey numbers for planar graphs

$(i, j)$	$R_{\mathcal{P}}(i, j)$	Reference
$i = 1, j \geq 1$	1	Lemma 9.1
$i = 2, j \geq 1$	$j$	Lemma 9.1
$i = 3, j \geq 1$	$3j - 3$	[75]
$i \geq 4, j \geq 1, (i, j) \neq (4, 2)$	$4j - 3$	[75]
$(4, 2)$	4	[75]

its line graph. It is easy to see that edgeless graphs and complete graphs belong to the class of line graphs. Let  $\mathcal{L}$  be the class of line graphs (of some undirected graphs). The Ramsey number for this class is known (see Table 9.2).



**Figure 9.2:** (a) A 4-node graph with 5 edges. (b) The corresponding 5-node line graph.

An undirected graph  $U = (V, E)$  is said to be a *fuzzy circular interval* graph [77] if there exists a set  $F$  of closed intervals of a circle  $C$ , none including

<sup>1</sup>The exact value is known and is given in [73].

**Table 9.2:** Ramsey numbers for line graphs

$(i, j)$	$R_{\mathcal{L}}(i, j)$	Reference
$i = 1, j \geq 1$	1	Lemma 9.1
$i = 2, j \geq 1$	$j$	Lemma 9.1
$i \geq 1, j = 1$	1	Lemma 9.1
$i \geq 1, j = 2$	$i$	Lemma 9.1
$i = 3, j \geq 3$	$\lfloor (5j - 3)/2 \rfloor$	[76]
$i \geq 4, j \geq 3$	$\leq i(j - 1) + 2^1$	[73]

another, such that no point of  $C$  is an endpoint of more than one interval in  $F$ , and a mapping  $\phi : V \rightarrow C$  such that if  $\{i, j\} \in E$ , then  $\phi(i)$  and  $\phi(j)$  belong to a common interval of  $F$ , and if  $\{i, j\} \notin E$ , then either there is no interval in  $F$  that contains both  $\phi(i)$  and  $\phi(j)$ , or there is exactly one interval in  $F$  whose endpoints are  $\phi(i)$  and  $\phi(j)$ . Note that an edgeless graph is a fuzzy circular interval graph ( $F = \emptyset$ ) and a complete graph is a fuzzy circular interval graph ( $F = \{C\}$ ). Figure 9.3 shows a more interesting example of  $\overline{C_6}$ . Let  $\mathcal{F}$  be the class of fuzzy circular interval graphs. The Ramsey number for this class is given in Table 9.3.

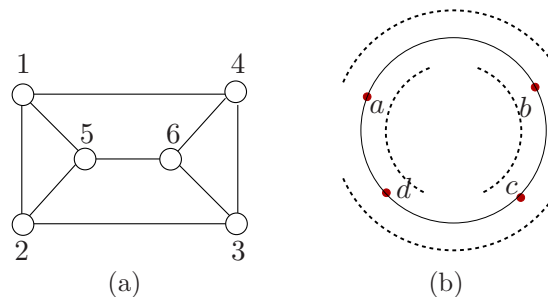

**Figure 9.3:** (a) The complement of  $C_6$ . (b) The fuzzy circular interval model of  $\overline{C_6}$  where the intervals are shown by dotted arcs and  $\phi(1) = \phi(2) = a$ ,  $\phi(3) = \phi(4) = b$ ,  $\phi(5) = d$ , and  $\phi(6) = c$ .

We summarize these results as a simple bilinear upper bound on the Ramsey number for the classes of planar, line, and fuzzy circular interval graphs.

**Table 9.3:** Ramsey numbers for fuzzy circular interval graphs

$(i, j)$	$R_{\mathcal{F}}(i, j)$	Reference
$i = 1, j \geq 1$	1	Lemma 9.1
$i = 2, j \geq 1$	$j$	Lemma 9.1
$i \geq 1, j = 1$	1	Lemma 9.1
$i \geq 1, j = 2$	$i$	Lemma 9.1
$i \geq 3, j \geq 3$	$(i - 1)j$	[73]

**Lemma 9.3.** For  $\mathcal{G} = \mathcal{P}, \mathcal{L},$  or  $\mathcal{F}$ ,

$$R_{\mathcal{G}}(i, j) \leq ij, \quad i, j \geq 1.$$

## 9.2 Approximate Capacity for Some Index Coding Classes

Blasiak, Kleinberg, and Lubetzky [23] stated the following approximation result for index coding instances with bidirectional side information graphs.

**Proposition 9.1** (Blasiak, Kleinberg, and Lubetzky [23]). *For any bidirectional (undirected) graph  $U$  with  $n$  nodes, the clique covering scheme approximates the broadcast rate of the index coding problem  $U$  within a multiplicative factor of  $O(n/\log n)$ .*

To prove this, consider the following lemma that indicates a relationship between the independence number of an undirected graph and the chromatic number of its complement via Ramsey numbers.

**Lemma 9.4** (Alon and Kahale [78]). *Let  $U = (V, E)$  be an undirected graph with  $|V| = n$ . Let  $t_i(m) = \max\{j: R(i, j) \leq m\}$ . If  $\chi(\bar{U}) \geq n/i + m$ , then an independent set of size  $t_i(m)$  can be found in  $U$ .*

Let  $i = \frac{1}{2} \log n$  and  $m = \frac{n}{i}$ . If  $\chi(\bar{U}) < \frac{4n}{\log n}$ , then  $\frac{\chi(\bar{U})}{\beta(\bar{U})} \leq \chi(\bar{U}) < \frac{4n}{\log n}$ . If  $\chi(\bar{U}) \geq \frac{4n}{\log n}$ , then for sufficiently large  $n$

$$\alpha(U) \geq \max \left\{ j : R\left(\frac{1}{2} \log n, j\right) \leq \frac{n}{i} \right\} \quad (9.1)$$

$$\geq \max \left\{ j : \left( \frac{\frac{1}{2} \log n + j - 2}{\frac{1}{2} \log n - 1} \right) \leq \frac{n}{i} \right\} \quad (9.2)$$

$$\geq \frac{1}{2} \log n,$$

where (9.1) follows by Lemma 9.4, and (9.2) follows by Lemma 9.2. Hence, using Remark 5.2, we have  $\frac{\chi(\bar{U})}{\beta(\bar{U})} \leq \frac{n}{\beta(\bar{U})} \leq \frac{n}{\alpha(\bar{U})} \leq O\left(\frac{n}{\log n}\right)$ , which completes the proof. The approximation result has also been generalized for directed graphs.

**Proposition 9.2** (Blasiak, Kleinberg, and Lubetzky [23]). *For any index coding problem with  $n$  messages, the fractional clique covering scheme approximates the broadcast rate within a multiplicative factor of  $O(n \log \log n / \log n)$ .*

To the best of our knowledge, the above approximation is the only algorithm to approximate the broadcast rate of a general (directed) index coding problem. In particular, no  $O(n^{1-\epsilon})$  approximation exists for any  $\epsilon > 0$ . In the following, we present such approximation for some classes of graphs. We first use a technique similar to the one used in the proof of Proposition 9.1 to present a condition under which there exists an approximation of the broadcast rate of an index coding problem  $U$  within a factor of  $O(n^{1-\epsilon})$  for some  $\epsilon > 0$ ; see Appendix 9.A for the proof.

**Theorem 9.1.** *Let  $\mathcal{G}$  be a class of undirected graphs for which  $R_{\mathcal{G}}(i, j) \leq ci^a j^b$  holds for some constants  $a, b$ , and  $c$ . Then the clique covering scheme approximates the broadcast rate of every  $n$ -node problem in  $\mathcal{G}$  within a multiplicative factor of  $2^{\frac{a+1}{a+b+1}} c^{\frac{1}{a+b+1}} n^{\frac{a+b}{a+b+1}}$ .*

As stated in Lemma 9.3, planar graphs, line graphs and fuzzy circular interval graphs are three classes that satisfy the condition of Theorem 9.1 with  $a = b = c = 1$ .

**Corollary 9.1.** If  $G$  is a planar graph or a line graph or a fuzzy circular interval graph with  $n$  nodes, the clique covering scheme approximates the broadcast rate within a multiplicative factor of  $(2n)^{2/3}$ .

Next, we consider the four-color theorem that states that the chromatic number of any planar graph is upper bounded by four.

**Theorem 9.2** (Appel, Haken, and Koch [79]). *Every planar graph  $U$  is four-colorable, i.e.,  $\chi(U) \leq 4$ .*

The four-color theorem for planar graphs makes it possible to provide a better approximation of the broadcast rate using simple lower and upper bounds.

If  $U(G)$  is planar,

$$\frac{n}{4} \leq \frac{n}{\chi(U(G))} \tag{9.3}$$

$$\leq \frac{n}{\chi_f(U(G))} \tag{9.4}$$

$$\leq \alpha(U(G)) \tag{9.5}$$

$$\leq \beta(U(G)) \tag{9.6}$$

$$\leq \beta(G) \tag{9.7}$$

$$\leq n,$$

where (9.3) follows by the four-color theorem, (9.4) by (2.2), (9.5) by Lemma 2.2, (9.6) by Remark 5.2 and (9.7) holds since adding side information decreases the

broadcast rate. If  $U(\bar{G})$  is planar,

$$1 \leq \beta(G) \leq \chi(U(\bar{G})) \leq 4.$$

The following summarizes these results.

**Theorem 9.3** ([80]). *If either  $U(G)$  or  $U(\bar{G})$  is planar, the broadcast rate can be approximated within a multiplicative factor of four.*

By Theorem 9.3, if  $U(G)$  ( $U(\bar{G})$ ) is planar then uncoded transmission (clique covering) is within a multiplicative factor of four from optimal. Note that Berliner and Langberg [81] showed that for index coding problems with outerplanar side information graph (which is a special case of planar graphs), the best performance over all scalar linear codes is achieved by the clique covering scheme.

Next, consider the class of unidirectional graphs. By Lemma 2.1, for any unidirectional graph  $G$  on  $n$  vertices

$$\log(n) \leq \beta(G') \leq \beta(G),$$

where  $G'$  is the tournament resulting from adding edges with arbitrary direction between the vertices that are not connected in  $G$ . This implies that for unidirectional graphs, uncoded transmission is within a factor of  $n/\log n$  from optimal.

Chapter 9, in full, is a reprint of the material in the papers: Fatemeh Arbabjolfaei and Young-Han Kim, “Approximate capacity of index coding for some classes of graphs”, *Proceedings of the IEEE International Symposium on Information Theory*, Barcelona, Spain, July 2016; and Fatemeh Arbabjolfaei and Young-Han Kim, “Elements of index coding”, to be submitted to *Foundations and Trends in Communications and Information Theory*. The dissertation author was

the primary investigator and author of these papers.

## 9.A Proof of Theorem 9.1

Let  $U \in \mathcal{G}$ . By Proposition 6.3,  $1 \leq \frac{\chi(\bar{U})}{\beta(U)}$ . Let  $k$  be a positive real number and consider two cases.

*Case 1:* If  $\chi(\bar{U}) < 2n/k$ , then  $\frac{\chi(\bar{U})}{\beta(U)} < 2n/k$ .

*Case 2:* If  $\chi(\bar{U}) \geq 2n/k$ , then

$$\begin{aligned} \left(\frac{n}{ck^{a+1}}\right)^{\frac{1}{b}} &= \max \{j: ck^a j^b \leq n/k\} \\ &\leq \max \{j: R_{\mathcal{G}}(k, j) \leq n/k\} \end{aligned} \tag{9.8}$$

$$= t_k(n/k) \tag{9.9}$$

$$\leq \alpha(U) \tag{9.10}$$

$$\leq \beta(U) \leq \chi(\bar{U}) \leq n,$$

where (9.8) follows by the assumption of the theorem, and (9.9) and (9.10) by letting  $m = n/k$  in Lemma 9.4. Thus,

$$\frac{\chi(\bar{U})}{\beta(U)} \leq \frac{n}{\beta(U)} \leq n^{1-\frac{1}{b}}(ck^{a+1})^{\frac{1}{b}}.$$

As  $k$  increases, the upper bound on  $\frac{\chi(\bar{U})}{\beta(U)}$  decreases in the first case, and increases in the second case. Hence, to minimize the upper bound on the multiplicative gap between  $\chi(\bar{U})$  and  $\beta(U)$ , we choose  $k = 2^{\frac{b}{a+b+1}}(n/c)^{\frac{1}{a+b+1}}$ , which makes the upper bounds in both cases to be equal to the desired multiplicative gap.



## Chapter 10

# Index Coding Versus Distributed Storage and Guessing Games

The index coding problem is closely related to the locally recoverable distributed storage problem, which studies fundamental limits and coding schemes for reliable data storage on a set of interconnected servers. The need to store data on a reliable distributed storage network is becoming increasingly urgent as the amount of data to be stored continues to expand. The locally recoverable distributed storage problem is equivalent to guessing game on directed graphs, which is a problem in recreational math area. In this section, we first overview the locally recoverable distributed storage problem and the problem of guessing game on graphs. Next, we elaborate on the relationship between these two problems and the index coding problem.

## 10.1 Locally Recoverable Distributed Storage Problem

In the locally recoverable distributed storage problem, which hereafter will be referred to as the distributed storage problem, a set of servers collectively store data such that if a server fails, its contents can be efficiently reconstructed from the contents of the other servers (among many others, see [82, 83, 84]). The goal is to design a distributed storage code that maximizes the amount of data that can be stored while satisfying the single-failure recovery constraint. Mazumdar [17] considered a distributed storage system in which each server has only access to a subset of the other servers and model the topology of the system by a directed graph. The same model was also considered in an independent concurrent work by Shanmugam and Dimakis [18].

Assume that there are  $n$  servers in the system and data is exactly recoverable by accessing all of the servers. Let  $x_i \in \{0, 1\}^{t_i}$  denote the content of server  $i \in [n]$ . Each server has access to the contents of a subset of other servers,  $x(A_i)$ ,  $A_i \subseteq [n] \setminus \{i\}$ . The set  $A_i$  is referred to as the recovery set of server  $i$ . The goal is to find the maximum amount of data that can be stored in the network so that if any single server fails, its content can be still recovered from the contents of its recovery set. Any instance of the distributed storage problem is fully represented by the *storage recovery graph*  $G = (V, E)$  in which each vertex represents a server and there exists a directed edge  $j \rightarrow i$  iff server  $j$  is in the recovery set of server  $i$ , i.e.,  $j \in A_i$ . We identify an instance of the distributed storage problem with its storage recovery graph  $G$  and often write “distributed storage problem  $G$ .”

A  $(t_1, \dots, t_n, r)$  distributed storage code is defined by

- a message set  $[2^r]$ ,

- a one-to-one encoding function  $x^n : [2^r] \rightarrow \prod_{i=1}^n \{0, 1\}^{t_i}$  that assigns a distinct codeword  $x^n(m)$  to each message  $m \in [2^r]$ , (the set  $\mathcal{C} = \{x^n(1), \dots, x^n(2^r)\}$  is referred to as the codebook), and
- $n$  recovery functions, where the recovery function at server  $i \in [n]$ ,  $f_i : \prod_{k \in A_i} \{0, 1\}^{t_k} \rightarrow \{0, 1\}^{t_i}$  maps the contents of the recovery set  $x(A_i)$  to  $x_i$ .

Thus, for every  $x^n \in \mathcal{C}$ ,

$$f(x(A_i)) = x_i, \quad i \in [n].$$

A rate tuple  $(R'_1, \dots, R'_n)$  is said to be *achievable* for the distributed storage problem  $G$  if there exists a  $(t_1, \dots, t_n, r)$  distributed storage code such that

$$R'_i \geq \frac{t_i}{r}, \quad i \in [n].$$

The *optimal rate region*  $\mathcal{R}$  of the distributed storage problem is defined as the closure of the set of achievable rate tuples.

For any nonnegative real tuple  $\boldsymbol{\lambda} = (\lambda_1, \dots, \lambda_n)$ , the  *$\boldsymbol{\lambda}$ -directed optimal rate*  $R(\boldsymbol{\lambda})$  of the distributed storage problem  $G$  is defined as

$$R(\boldsymbol{\lambda}) = \min\{R' : R'\boldsymbol{\lambda} \in \mathcal{R}\}. \quad (10.1)$$

The **1**-directed optimal rate of the distributed storage problem  $G$  is referred to as the *symmetric coding rate*,

$$R_{\text{sym}} = R(\mathbf{1}) = \min\{R' : (R', \dots, R') \in \mathcal{R}\}.$$

The reciprocal of the symmetric coding rate is sometimes referred to as the *normalized rate*.

**Remark 10.1.** The optimal rate region can be written in terms of  $\boldsymbol{\lambda}$ -directed optimal rates.

$$\mathcal{R} = \bigcup_{\boldsymbol{\lambda}} \{\mathbf{R}' \in \mathbb{R}^n : \mathbf{R}' \geq R(\boldsymbol{\lambda})\boldsymbol{\lambda}\}. \quad (10.2)$$

Note that if  $\lambda = c\lambda'$  for some constant  $c$ , then  $R(\lambda)\lambda = R(\lambda')\lambda'$  and thus, it suffices to take the union in (10.2) only over normalized vectors, e.g., over  $\lambda$  such that  $\sum_{j=1}^n \lambda_j = n$ .

For any nonnegative real vector  $\boldsymbol{\mu} = (\mu_1, \dots, \mu_n)$ , the  $\boldsymbol{\mu}$ -weighted optimal sum-rate  $\bar{R}(\boldsymbol{\mu})$  of the distributed storage problem  $G$  is defined as

$$\bar{R}(\boldsymbol{\mu}) = \min \left\{ \sum_{j=1}^n \mu_j R'_j : (R'_1, \dots, R'_n) \in \mathcal{R} \right\}.$$

The  $\mathbf{1}$ -weighted optimal sum-rate  $\bar{R}(\mathbf{1})$  is simply referred to as the *optimal sum-rate*

$$R_{\text{sum}} = \bar{R}(\mathbf{1}) = \min \left\{ \sum_{j=1}^n R'_j : (R'_1, \dots, R'_n) \in \mathcal{R} \right\}.$$

Given a storage recovery graph  $G$  and an integer tuple  $\mathbf{t} = (t_1, \dots, t_n)$ , consider the confusion graph  $\Gamma = \Gamma_{\mathbf{t}}(G)$  as defined in Section 3. By definition, no two  $n$ -tuples in a maximal independent set of the confusion graph  $\Gamma$  are confusable and therefore, for these  $\alpha(\Gamma)$   $n$ -tuples, contents of each server is a function of the contents of its recoverability set. Therefore, it is possible to use these  $\alpha(\Gamma)$   $n$ -tuples to store  $r = \lfloor \log(\alpha(\Gamma)) \rfloor$  bits in the distributed network. This proves the existence of a  $(t_1, \dots, t_n, \lfloor \log(\alpha(\Gamma_{\mathbf{t}}(G))) \rfloor)$  distributed storage code. Conversely, consider any  $(t_1, \dots, t_n, r)$  distributed storage code, which has at least  $2^r$  distinct  $n$ -tuples that satisfy the required function relationship. By definition, these  $n$ -tuples form an independent set of the confusion graph  $\Gamma = \Gamma_{\mathbf{t}}(G)$ . Thus,  $\alpha(\Gamma) \geq 2^r$ , or

equivalently,  $r \leq \lfloor \log(\alpha(\Gamma)) \rfloor$ . Therefore, any achievable  $(R'_1, \dots, R'_n)$  must satisfy

$$R'_i \geq \frac{t_i}{\lfloor \log(\alpha(\Gamma_{\mathbf{t}}(G))) \rfloor}, \quad i \in [n],$$

for some  $\mathbf{t} = (t_1, \dots, t_n)$ . This establishes the following.

**Proposition 10.1** ([17, 19]). *The optimal rate region  $\mathcal{R}$  of the distributed storage problem  $G$  is the closure of all rate tuples  $(R'_1, \dots, R'_n)$  such that*

$$R'_i \geq \frac{t_i}{\log(\alpha(\Gamma_{\mathbf{t}}))}, \quad i \in [n],$$

for some  $\mathbf{t} = (t_1, \dots, t_n)$ .

## 10.2 Guessing game on Directed Graphs

Given a directed graph  $G = (V, E)$ ,  $V = [n]$ , consider the following cooperative game among  $n$  players. Player  $i \in [n]$  is associated to vertex  $i$  and is assigned a value  $x_i \in \{0, 1\}^{t_i}$  independently from the other players. Assume that player  $i$  can observe  $x(A_i)$  assigned to the players in her neighbor set  $A_i \subseteq [n] \setminus \{i\}$ . The players guess simultaneously their own value and win if all of them guess their value correctly. No communication is allowed between the players, but they can agree on a strategy beforehand. The goal is to find the maximum winning probability and the strategy that achieves this maximum. This mathematical riddle, named the guessing game on a graph, was introduced by Riis [14]. The setting presented here is slightly different from his in that the range of the values assigned to the players can be different.

As an example, consider the guessing game on a complete graph with  $n$  vertices and assume that  $t_i = 1$ ,  $i \in [n]$ . If every player guesses her value randomly,

then the players win with probability  $1/2^n$ . Consider the following strategy. Each player guesses her own value assuming that the sum of all the values is even. Since every player can observe the values of all other players, the players win iff their assumption is correct, which happens with probability  $1/2$ . This strategy makes a significant improvement over the random guessing and is optimal, as the probability that a single player guesses her value correctly is also  $1/2$ .

Now we formalize the problem with the following definition. A  $(t_1, \dots, t_n, W)$  guessing strategy consists of

- $n$  guessing functions, where the guessing function of player  $i \in [n]$ ,  $h_i : \prod_{j \in A_i} \{0, 1\}^{t_j} \rightarrow \{0, 1\}^{t_i}$ , maps the values of the neighbors  $x(A_i)$  to  $x_i$  and
- a set  $W$  of  $n$ -tuples that can be guessed correctly using these functions,

$$W := \bigcap_{i=1}^n \left\{ x^n \in \prod_{j=1}^n \{0, 1\}^{t_j} : h_i(x(A_i)) = x_i \right\}.$$

Let  $P_{\text{win}}$  be the probability of winning, namely, the probability that everyone guesses her value correctly. If the players adopt a  $(t_1, \dots, t_n, W)$  strategy, then

$$P_{\text{win}} = \frac{|W|}{\prod_{i=1}^n 2^{t_i}}.$$

Let  $P_{\text{rand}}$  be the probability of winning if every player guesses her value randomly. As player  $i \in [n]$  is correct with probability  $1/2^{t_i}$  independent of others, we have

$$P_{\text{rand}} = \frac{1}{\prod_{i=1}^n 2^{t_i}}.$$

The performance of a given guessing strategy can be measured by the notion of guessing number (see [14] for the symmetric case).

**Definition 10.1.** Given a directed graph  $G$ , the guessing number of a  $(t_1, \dots, t_n, W)$  guessing strategy is

$$k(G, \mathbf{t}) = \log_s \left( \frac{P_{\text{win}}}{P_{\text{rand}}} \right) = \frac{n \log |W|}{\sum_{i \in [n]} t_i}, \quad (10.3)$$

where  $s = 2^{\frac{1}{n} \sum_{i \in [n]} t_i}$ .

Note that for the case in which  $t_i = t, i \in [n]$ , we have  $k(G, t) = \log(|W|)/t$ . The optimal guessing number  $k(G)$  of a directed graph  $G$  is defined as

$$k(G) = \sup_{\mathbf{t}} \sup k(G, \mathbf{t}), \quad (10.4)$$

where the second supremum is over all  $(t_1, \dots, t_n, W)$  strategies. The following is an alternative way to measure the performance of adopting a strategy.

**Definition 10.2.** Given a directed graph  $G$ , the complementary guessing number of a  $(t_1, \dots, t_n, W)$  guessing strategy is defined as

$$k'(G, \mathbf{t}) = \log_s (1/P_{\text{win}}), \quad (10.5)$$

where  $s = 2^{\frac{1}{n} \sum_{i \in [n]} t_i}$  and  $P_{\text{win}}$  is the probability that the players win if they adopt that strategy.

The optimal complementary guessing number is defined in a similar way.

$$k'(G) = \inf_{\mathbf{t}} \inf k'(G, \mathbf{t}), \quad (10.6)$$

where the second infimum is over all  $(t_1, \dots, t_n, W)$  guessing strategies.

**Remark 10.2.** For any  $(t_1, \dots, t_n, W)$  guessing strategy, we have  $k'(G, \mathbf{t}) = n -$

$k(G, \mathbf{t})$ , and thus

$$k'(G) = n - k(G). \quad (10.7)$$

As in index coding and distributed storage problems, the confusion graph  $\Gamma_{\mathbf{t}}(G)$  defined in Section 3 for a given directed graph  $G$  and an integer tuple  $\mathbf{t} = (t_1, \dots, t_n)$  is useful in characterizing the optimal guessing number of the guessing game on graph  $G$ . Using an argument similar to the proof of Proposition 10.1, for any  $\mathbf{t} = (t_1, \dots, t_n)$  the optimal guessing strategy has winning probability  $P_{\text{win}} = \alpha(\Gamma_{\mathbf{t}}) / \prod_{i \in [n]} 2^{t_i}$  and thus,

$$k(G, \mathbf{t}) = \frac{n \log(\alpha(\Gamma_{\mathbf{t}}))}{\sum_{i \in [n]} t_i},$$

which implies the following.

**Proposition 10.2.** *For the guessing game on directed graph  $G$  on  $n$  vertices we have*

$$k(G) = \sup_{\mathbf{t}} \frac{n \log(\alpha(\Gamma_{\mathbf{t}}))}{\sum_{i \in [n]} t_i}.$$



## 10.3 Equivalence Between Distributed Storage and Guessing Games

For any integer tuple  $\mathbf{t} = (t_1, \dots, t_n)$ , let  $s(\mathbf{t}) = 2^{\frac{1}{n} \sum_{i \in [n]} t_i}$ , then

$$\begin{aligned} R_{\text{sum}} &= \min_{R' \in \mathcal{R}} \sum_{i=1}^n R'_i \\ &= \inf_{\mathbf{t}} \frac{\sum_{i \in [n]} t_i}{\log(\alpha(\Gamma_{\mathbf{t}}))} \end{aligned} \tag{10.8}$$

$$= \frac{n}{\sup_{\mathbf{t}} \frac{\log(\alpha(\Gamma_{\mathbf{t}}))}{\log(s(\mathbf{t}))}} = \frac{n}{k(G)}, \tag{10.9}$$

where (10.8) follows by Proposition 10.1, and (10.9) follows by Proposition 10.2. Hence, for any directed graph  $G$ , the optimal guessing number of the guessing game on  $G$  is inversely related to the optimal sum-rate of the distributed storage problem  $G$ .

**Theorem 10.1.** *For any directed graph  $G$  on  $n$  nodes*

$$k(G) = \frac{n}{R_{\text{sum}}}.$$

In fact the guessing game is equivalent to the distributed storage problem in the following strong sense, which can be used to prove Theorem 10.1 without involving confusion graphs.

**Theorem 10.2.** *Given any directed graph  $G$ , a  $(t_1, \dots, t_n, W)$  guessing strategy exists iff a  $(t_1, \dots, t_n, r)$  distributed storage code exists with  $r = \lfloor \log |W| \rfloor$ .*

To prove this, consider a  $(t_1, \dots, t_n, W)$  guessing strategy. We can construct a  $(t_1, \dots, t_n, r)$  distributed storage code by using the set of  $n$ -tuples  $W$  as the set of codewords to store  $2^r$ ,  $r = \lfloor \log |W| \rfloor$ , messages and using guessing functions  $h_i, i \in$

$[n]$ , as the recovery functions. Conversely, consider a  $(t_1, \dots, t_n, r)$  distributed storage code. Setting  $W = \{x^n(m) : m \in [2^r]\}$  and using the recovery function  $f_i$  as the guessing function of player  $i \in [n]$ , we can construct a  $(t_1, \dots, t_n, W)$  guessing strategy with  $|W| = 2^r$ .

## 10.4 Complementarity Between Index Coding and Distributed Storage

For any length- $n$  integer tuple  $\mathbf{t}$ , the confusion graph  $\Gamma_{\mathbf{t}}$  is vertex transitive. Therefore, by Lemma 2.2,

$$\log(\chi_f(\Gamma_{\mathbf{t}})) = \sum_{i \in [n]} t_i - \log(\alpha(\Gamma_{\mathbf{t}})). \quad (10.10)$$

Based on (10.10) and the following, we can establish a complementarity relationship between the  $\boldsymbol{\lambda}$ -directed capacity  $C(\boldsymbol{\lambda})$  and the  $\boldsymbol{\lambda}$ -directed optimal rate  $R(\boldsymbol{\lambda})$ , for any nonnegative real tuple  $\boldsymbol{\lambda}$ .

**Proposition 10.3.** *For any directed graph  $G$  on  $n$  nodes and any  $\boldsymbol{\lambda} \in \mathbb{Q}_{\geq 0}^n$ ,*

$$C(\boldsymbol{\lambda}) = \sup_{r: r\boldsymbol{\lambda} \in \mathbb{Z}_{\geq 0}^n} \frac{r}{\log(\chi_f(\Gamma_{r\boldsymbol{\lambda}}(G)))}, \quad (10.11)$$

$$R(\boldsymbol{\lambda}) = \inf_{r: r\boldsymbol{\lambda} \in \mathbb{Z}_{\geq 0}^n} \frac{r}{\log(\alpha(\Gamma_{r\boldsymbol{\lambda}}(G)))}. \quad (10.12)$$

The proof of the Proposition is relegated to Appendix 10.A. Now for  $\boldsymbol{\lambda} \in$

$\mathbb{Q}_{\geq 0}^n$ , we have

$$C(\boldsymbol{\lambda}) = \sup_{r:r\boldsymbol{\lambda} \in \mathbb{Z}_{\geq 0}^n} \frac{r}{\log(\chi_f(\Gamma_{r\boldsymbol{\lambda}}(G)))} \quad (10.13)$$

$$= \sup_{r:r\boldsymbol{\lambda} \in \mathbb{Z}_{\geq 0}^n} \frac{r}{r \sum_{i=1}^n \lambda_i - \log(\alpha(\Gamma_{r\boldsymbol{\lambda}}(G)))} \quad (10.14)$$

$$= \frac{1}{\sum_{i=1}^n \lambda_i - \frac{1}{R(\boldsymbol{\lambda})}}, \quad (10.15)$$

where (10.13) and (10.15) follow from Proposition 10.3, and (10.14) follows by (10.10). By the continuity of the functions  $C(\boldsymbol{\lambda})$  and  $R(\boldsymbol{\lambda})$  and  $\mathbb{Q}$  being dense in  $\mathbb{R}$  we have the following.

**Theorem 10.3** ([19]). *For any directed graph  $G$  on  $n$  nodes and any  $\boldsymbol{\lambda} \in \mathbb{R}_{\geq 0}^n$*

$$\frac{1}{C(\boldsymbol{\lambda})} = \sum_{i=1}^n \lambda_i - \frac{1}{R(\boldsymbol{\lambda})}. \quad (10.16)$$

By (1.2) and (10.2), the above theorem establishes the complementarity between the two problems in the strong sense that given the capacity region of the index coding problem  $G$  (more precisely, given the boundary points of the capacity region), Theorem 10.3 completely determines the optimal rate region for the distributed storage problem  $G$  and vice versa. This includes as a special case the complementarity between the symmetric capacity of the index coding problem and the symmetric coding rate of the distributed storage established by Mazumdar [17], and by Shanmugam and Dimakis [18].

**Corollary 10.1.** Setting  $\boldsymbol{\lambda} = \mathbf{1}$  in Theorem 10.3 yields

$$\frac{1}{C_{\text{sym}}} = n - \frac{1}{R_{\text{sym}}}. \quad (10.17)$$

Equation (10.10) can also be used to show how the sum-capacity of the

index coding problem is related to the optimal sum-rate of the distributed storage problem.

**Theorem 10.4** ([19]).

$$\frac{1}{C_{\text{sum}}} = 1 - \frac{1}{R_{\text{sum}}}. \quad (10.18)$$

To see why (10.18) holds, consider

$$\begin{aligned} \frac{1}{C_{\text{sum}}} &= \frac{1}{\max_{\mathbf{R} \in \mathcal{C}} \sum_{i=1}^n R_i} \\ &= \frac{1}{\sup_{\mathbf{t}} \frac{\sum_{i \in [n]} t_i}{\log(\chi_f(\Gamma_{\mathbf{t}}))}} \end{aligned} \quad (10.19)$$

$$= \inf_{\mathbf{t}} \frac{\sum_{i \in [n]} t_i - \log(\alpha(\Gamma_{\mathbf{t}}))}{\sum_{i \in [n]} t_i} \quad (10.20)$$

$$= 1 - \frac{1}{\min_{\mathbf{R}' \in \mathcal{R}} \sum_{i=1}^n R'_i} = 1 - \frac{1}{R_{\text{sum}}}, \quad (10.21)$$

where (10.19) follows by Proposition 3.4, (10.20) follows by (10.10), and (10.21) follows by Proposition 10.1.

Combining Theorems 10.4 and 10.1, and (10.7) yields the inverse relationship between the optimal complementary guessing number and the index coding sum-capacity.

**Corollary 10.2.** For any directed graph  $G$  on  $n$  nodes

$$k'(G) = \frac{n}{C_{\text{sum}}}.$$

The relationship between index coding, distributed storage, and guessing game on directed graphs is summarized in Figure 10.1. Note that by Theorem 10.2, distributed storage and guessing game are equivalent; however, optimal guessing

number and complementary guessing number, by definition, consider only a specific direction.

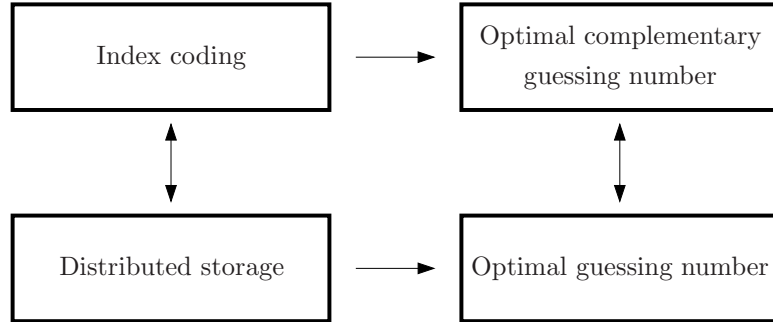

**Figure 10.1:** The relationship between index coding, distributed storage, optimal guessing number, and optimal complementary guessing number.

Chapter 10, in full, is a reprint of the material in the papers: Fatemeh Arbabjolfaei and Young-Han Kim, “Three stories on a two-sided coin: index coding, locally recoverable distributed storage, and guessing games on graphs”, *Proceedings of the 53rd Annual Allerton Conference on Communication, Control, and Computing*, Monticello, Illinois, Oct. 2015; and Fatemeh Arbabjolfaei and Young-Han Kim, “Elements of index coding”, to be submitted to *Foundations and Trends in Communications and Information Theory*. The dissertation author was the primary investigator and author of these papers.

## 10.A Proof of Proposition 10.3

To prove Proposition 10.3, we first need to prove two lemmas. By Proposition 3.4,  $\mathcal{C} = cl(\mathcal{C}^\circ)$ , where

$$\mathcal{C}^\circ = \{(R_1, \dots, R_n) \in \mathbb{R}_{\geq 0}^n : R_i \leq \frac{t_i}{\log(\chi_f(\Gamma_{\mathbf{t}}(G)))} \text{ for some } (t_1, \dots, t_n) \in \mathbb{Z}_{\geq 0}^n\}.$$

The following lemma shows that the  $\boldsymbol{\lambda}$ -directed capacity defined in (1.1), can also be defined in terms of  $\mathcal{C}^\circ$ .

**Lemma 10.1.** *For any non-negative real tuple  $\boldsymbol{\lambda}$ ,*

$$C(\boldsymbol{\lambda}) = \sup\{R: R\boldsymbol{\lambda} \in \mathcal{C}^\circ\}. \quad (10.22)$$

*Proof:* Let  $R^* = \sup\{R: R\boldsymbol{\lambda} \in \mathcal{C}^\circ\}$ , then  $R^*\boldsymbol{\lambda} \in \mathcal{C}$  and by the definition of  $C(\boldsymbol{\lambda})$  we have  $R^* \leq C(\boldsymbol{\lambda})$ .

Assume that  $R^* < C(\boldsymbol{\lambda})$ . Let

$$\epsilon = \frac{1}{2}(C(\boldsymbol{\lambda}) - R^*) \min_{i:\lambda_i>0} \lambda_i,$$

and define the  $\epsilon$ -neighborhood  $N_\epsilon(C(\boldsymbol{\lambda})\boldsymbol{\lambda})$  as

$$N_\epsilon(C(\boldsymbol{\lambda})\boldsymbol{\lambda}) = \bigcap_{i:\lambda_i>0} \{\mathbf{R} \in \mathbb{R}^n: e_i^T(C(\boldsymbol{\lambda})\boldsymbol{\lambda} - \mathbf{R}) < \epsilon\},$$

where all of the components of the  $n \times 1$  vector  $e_i$  are zero, except the  $i$ -th component, which is one. If  $N_\epsilon(C(\boldsymbol{\lambda})\boldsymbol{\lambda}) \cap \mathcal{C}^\circ = \emptyset$ , then it contradicts the fact that  $C(\boldsymbol{\lambda})\boldsymbol{\lambda}$  belongs to  $\mathcal{C}$ . Alternatively, if  $N_\epsilon(C(\boldsymbol{\lambda})\boldsymbol{\lambda}) \cap \mathcal{C}^\circ \neq \emptyset$ , then there exists  $R > R^*$  such that  $R\boldsymbol{\lambda} \in \mathcal{C}^\circ$ , which contradicts the definition of  $R^*$ . Therefore,  $R^* = C(\boldsymbol{\lambda})$  and the proof is complete.  $\square$

The following lemma shows that given any directed graph  $G$ , the confusion graph corresponding to a larger integer tuple has a larger fractional chromatic number.

**Lemma 10.2.** *Let  $\mathbf{s} = (s_1, \dots, s_n)$  and  $\mathbf{t} = (t_1, \dots, t_n)$  be two integer tuples such*

that  $\mathbf{s} \leq \mathbf{t}$ . Then for any directed graph  $G$  with  $n$  vertices, we have

$$\chi_f(\Gamma_{\mathbf{s}}(G)) \leq \chi_f(\Gamma_{\mathbf{t}}(G)). \quad (10.23)$$

*Proof:* First assume that  $s_i + k = t_i$  for some  $i \in [n]$  and some positive integer  $k$  and  $s_j = t_j, \forall j \neq i$ . In this case, we will prove the lemma by contradiction. Assume that (10.23) does not hold. Then as any confusion graph is vertex transitive, by Lemma 2.2, we have

$$\alpha(\Gamma_{\mathbf{t}}(G)) > 2^k \alpha(\Gamma_{\mathbf{s}}(G)). \quad (10.24)$$

Each vertex of  $\Gamma_{\mathbf{t}}$  is associated with an  $n$ -tuple that has  $t_j$  bits for user  $j \in [n]$ . Consider the  $\alpha(\Gamma_{\mathbf{t}})$   $n$ -tuples in a maximal independent set of  $\Gamma_{\mathbf{t}}$  and partition them into (at most  $2^k$ ) subsets based on the first  $k$  bits of user  $i$ . As these  $k$  bits are the same for all the members of each partition, after removing these  $k$  bits from all the  $n$ -tuples, each partition will correspond to an independent set of  $\Gamma_{\mathbf{s}}$ . However, there are at most  $2^k$  partitions and hence if (10.24) holds, due to the pigeonhole principle, there exists a partition with more than  $\alpha(\Gamma_{\mathbf{s}})$  members, i.e., there exists an independent set of size more than  $\alpha(\Gamma_{\mathbf{s}})$  in  $\Gamma_{\mathbf{s}}$ , which contradicts the definition of the independence number of a graph. Therefore, (10.23) holds if the two integer tuples differ only at one element. Applying this (at most  $n$  times) to length- $n$  tuples that differ only at one element, completes the proof of the lemma.  $\square$

Now we can proceed with the proof of Proposition 10.3. Let  $\lambda = (\frac{a_1}{b}, \dots, \frac{a_n}{b})^T$ ,  $b \in \mathbb{N}$ , and  $a_1, \dots, a_n \in \mathbb{Z}_{\geq 0}$ . If  $r\lambda \in \mathbb{Z}_{\geq 0}^n$ , then by Proposition 3.4, we have

$$\frac{r\lambda}{\log(\chi_f(\Gamma_{r\lambda}(G)))} \in \mathcal{C}.$$

Therefore, we have

$$C(\boldsymbol{\lambda}) \geq \sup_{r:r\boldsymbol{\lambda} \in \mathbb{Z}_{\geq 0}^n} \frac{r}{\log(\chi_f(\Gamma_{r\boldsymbol{\lambda}}(G)))}.$$

Next, let  $R$  be any real number such that  $R\boldsymbol{\lambda} \in \mathcal{E}^0$ . Then, there exists integer tuple  $\mathbf{t}$  such that  $R\boldsymbol{\lambda} \leq \mathbf{t}/\log(\chi_f(\Gamma_{\mathbf{t}}))$ , and hence  $R \leq \frac{t_i}{\lambda_i}/\log(\chi_f(\Gamma_{\mathbf{t}}))$ , for all  $i$  such that  $\lambda_i > 0$ . Let

$$j = \arg \min_{i:\lambda_i > 0} \frac{t_i}{\lambda_i}, \quad (10.25)$$

then we have

$$R \leq \frac{q}{a_j \log(\chi_f(\Gamma_{\mathbf{t}}))}, \quad (10.26)$$

where  $q = t_j b$ . By (10.25),  $a_j \mathbf{t} \geq q\boldsymbol{\lambda} = t_j(a_1, \dots, a_n)^T \in \mathbb{Z}_{\geq 0}^n$  and we have

$$\log(\chi_f(\Gamma_{q\boldsymbol{\lambda}})) \leq \log(\chi_f(\Gamma_{a_j \mathbf{t}})) \quad (10.27)$$

$$\leq \log(\chi_f(\Gamma_{\mathbf{t}}^{a_j})) \quad (10.28)$$

$$= a_j \log(\chi_f(\Gamma_{\mathbf{t}})), \quad (10.29)$$

where (10.27) follows by Lemma 10.2, (10.28) follows by the fact that the set of edges of  $\Gamma_{a_j \mathbf{t}}$  is a subset of the set of edges of  $\Gamma_{\mathbf{t}}^{a_j}$ , and (10.29) follows by Lemma 2.5. Combining (10.26) and (10.29), we have

$$R \leq \frac{q}{\log(\chi_f(\Gamma_{q\boldsymbol{\lambda}}))} \leq \sup_{r:r\boldsymbol{\lambda} \in \mathbb{Z}_{\geq 0}^n} \frac{r}{\log(\chi_f(\Gamma_{r\boldsymbol{\lambda}}(G)))},$$

which together with Lemma 10.1 yields

$$C(\boldsymbol{\lambda}) \leq \sup_{r:r\boldsymbol{\lambda} \in \mathbb{Z}_{\geq 0}^n} \frac{r}{\log(\chi_f(\Gamma_{r\boldsymbol{\lambda}}(G)))},$$



and hence (10.11) holds. Following similar steps as above, one can show that (10.12) also holds.

# Bibliography

- [1] M. Fekete, “Über die verteilung der wurzeln bei gewissen algebraischen gleichungen mit ganzzahligen koeffizienten,” *Mathematische Zeitschrift*, vol. 17, pp. 228–249, 1923.
- [2] “The on-line encyclopedia of integer sequences.” [Online]. Available: <https://oeis.org/A000273>
- [3] Y. Birk and T. Kol, “Informed-source coding-on-demand (ISCOD) over broadcast channels,” in *Proc. 17th Ann. IEEE Int. Conf. Comput. Commun. (INFOCOM)*, San Francisco, CA, Mar. 1998, pp. 1257–1264.
- [4] —, “Coding on demand by an informed source (ISCOD) for efficient broadcast of different supplemental data to caching clients,” *IEEE Trans. Inf. Theory*, vol. 52, no. 6, pp. 2825–2830, Jun. 2006.
- [5] Z. Bar-Yossef, Y. Birk, T. S. Jayram, and T. Kol, “Index coding with side information,” in *47th Ann. IEEE Symp. Found. Comput. Sci.*, Berkeley, CA, Oct. 2006, pp. 197–206.
- [6] M. Celebiler and G. Stette, “On increasing the down-link capacity of a regenerative satellite repeater in point-to-point communications,” *Proc. IEEE*, vol. 66, no. 1, pp. 98–100, Jan. 1978.
- [7] F. M. J. Willems, J. K. Wolf, and A. D. Wyner, “Communicating via a processing broadcast satellite,” in *IEEE/CAM Inf. Theory Workshop*, Cornell, NY, 1989, pp. 3–1.
- [8] A. D. Wyner, J. K. Wolf, and F. M. J. Willems, “Communicating via a processing broadcast satellite,” *IEEE Trans. Inf. Theory*, vol. 48, no. 6, pp. 1243–1249, 2002.
- [9] R. W. Yeung, “Multilevel diversity coding with distortion,” *IEEE Trans. Inf. Theory*, vol. 41, no. 2, pp. 412–422, 1995.

- [10] M. Neely, A. Tehrani, and Z. Zhang, “Dynamic index coding for wireless broadcast networks,” in *Proc. 31st Ann. IEEE Int. Conf. Comput. Commun. (INFOCOM)*, Orlando, FL, Mar. 2012, pp. 316–324.
- [11] S. A. Jafar, “Topological interference management through index coding,” *IEEE Trans. Inf. Theory*, vol. 60, no. 1, pp. 529–468, Jan. 2014.
- [12] M. A. Maddah-Ali and U. Niesen, “Fundamental limits of caching,” *IEEE Trans. Inf. Theory*, vol. 60, no. 5, pp. 2856–2867, 2014.
- [13] M. Ji, G. Caire, and A. F. Molisch, “Fundamental limits of caching in wireless D2D networks,” *IEEE Trans. Inf. Theory*, vol. 62, no. 2, pp. 849–869, 2016.
- [14] S. Riis, “Information flows, graphs and their guessing numbers,” *Elec. J. Comb.*, vol. 14, no. R44, Jun. 2007.
- [15] S. El Rouayheb, A. Sprintson, and C. Georghiades, “On the relation between the index coding and the network coding problems,” in *Proc. IEEE Int. Symp. Inf. Theory*, Toronto, ON, Jul. 2008, pp. 1823–1827.
- [16] M. Effros, S. El Rouayheb, and M. Langberg, “An equivalence between network coding and index coding,” *IEEE Trans. Inf. Theory*, vol. 61, no. 5, pp. 2478–2487, May 2015.
- [17] A. Mazumdar, “On a duality between recoverable distributed storage and index coding,” in *Proc. IEEE Int. Symp. Inf. Theory*, Honolulu, HI, Jul. 2014, pp. 1977–1981.
- [18] K. Shanmugam and A. G. Dimakis, “Bounding multiple unicasts through index coding and locally repairable codes,” in *Proc. IEEE Int. Symp. Inf. Theory*, Honolulu, HI, Jul. 2014, pp. 296–300.
- [19] F. Arbabjolfaei and Y.-H. Kim, “Three stories on a two-sided coin: Index coding, locally recoverable distributed storage, and guessing games on graph,” in *Proc. 53rd Ann. Allerton Conf. Comm. Control Comput.*, Monticello, IL, Oct. 2015.
- [20] X. Yi, H. Sun, S. A. Jafar, and D. Gesbert, “Fractional coloring (orthogonal access) achieves all-unicast capacity (DoF) region of index coding (TIM) if and only if network topology is chordal,” 2015. [Online]. Available: <http://arxiv.org/abs/1501.07870>
- [21] S. El Rouayheb, A. Sprintson, and C. Georghiades, “On the index coding problem and its relation to network coding and matroid theory,” *IEEE Trans. Inf. Theory*, vol. 56, no. 7, pp. 3187–3195, Jul. 2010.

- [22] K. Shanmugam, M. Asteris, and A. G. Dimakis, "On approximating the sum-rate for multiple-unicasts," in *Proc. IEEE Int. Symp. Inf. Theory*, Hong Kong, Jun. 2015, pp. 381–385.
- [23] A. Blasiak, R. Kleinberg, and E. Lubetzky, "Broadcasting with side information: Bounding and approximating the broadcast rate," *IEEE Trans. Inf. Theory*, vol. 59, no. 9, pp. 5811–5823, Sep. 2013.
- [24] K. Shanmugam, A. G. Dimakis, and M. Langberg, "Graph theory versus minimum rank for index coding," in *Proc. IEEE Int. Symp. Inf. Theory*, Honolulu, HI, June/July 2014, pp. 291–295.
- [25] Z. Bar-Yossef, Y. Birk, T. S. Jayram, and T. Kol, "Index coding with side information," *IEEE Trans. Inf. Theory*, vol. 57, no. 3, pp. 1479–1494, Mar. 2011.
- [26] E. Lubetzky and U. Stav, "Nonlinear index coding outperforming the linear optimum," *IEEE Trans. Inf. Theory*, vol. 55, no. 8, pp. 3544–3551, Aug. 2009.
- [27] F. Arbabjolfaei, B. Bandemer, Y.-H. Kim, E. Sasoglu, and L. Wang, "On the capacity region for index coding," in *Proc. IEEE Int. Symp. Inf. Theory*, Istanbul, Turkey, Jul. 2013, pp. 962–966.
- [28] L. Ong, F. Lim, and C. K. Ho, "The multi-sender multicast index coding," in *Proc. IEEE Int. Symp. Inf. Theory*, Istanbul, Turkey, Jul. 2013, pp. 1147–1151.
- [29] F. Arbabjolfaei, B. Bandemer, and Y.-H. Kim, "Index coding via random coding," in *Iran Workshop on Communication and Information Theory (IWCIT 2014)*, Tehran, Iran, May 2014.
- [30] F. Arbabjolfaei and Y.-H. Kim, "Local time sharing for index coding," in *Proc. IEEE Int. Symp. Inf. Theory*, Honolulu, HI, Jul. 2014, pp. 286–290.
- [31] S. Unal and A. Wagner, "A rate-distortion approach to index coding," in *Proc. UCSD Inf. Theory Appl. Workshop*, San Diego, CA, Jul. 2014, pp. 1–5.
- [32] H. Maleki, V. R. Cadambe, and S. A. Jafar, "Index coding an interference alignment perspective," *IEEE Trans. Inf. Theory*, vol. 60, no. 9, pp. 5402–5432, Sep. 2014.
- [33] H. Sun and S. A. Jafar, "Index coding capacity: How far can one go with only shannon inequalities?" *IEEE Trans. Inf. Theory*, vol. 61, no. 6, pp. 3041–3055, Jun. 2015.
- [34] X. Huang and S. El Rouayheb, "Index coding and network coding via rank minimization," in *Proc. IEEE Inf. Theory Workshop*, Jeju Island, Korea, Oct. 2015, pp. 14–18.

- [35] R. W. Yeung and Z. Zhang, “Distributed source coding for satellite communications,” *IEEE Trans. Inf. Theory*, vol. 45, no. 4, pp. 1111–1120, 1999.
- [36] R. Dougherty, C. Freiling, and K. Zeger, “Network coding and matroid theory,” *Proc. IEEE*, vol. 99, no. 3, pp. 388–405, Mar. 2011.
- [37] A. Blasiak, R. Kleinberg, and E. Lubetzky, “Lexicographic products and the power of non-linear network coding,” in *52nd Ann. IEEE Symp. Found. Comput. Sci.*, Palm Springs, CA, Oct. 2011, pp. 609–618.
- [38] R. Baber, D. Christofides, A. N. Dang, S. Riis, and E. R. Vaughan, “Multiple unicasts, graph guessing games, and non-shannon inequalities,” in *Proc. Int. Symp. on Network Coding*, Calgary, AB, Jun. 2013, pp. 1–6.
- [39] M. Langberg and A. Sprintson, “On the hardness of approximating the network coding capacity,” *IEEE Trans. Inf. Theory*, vol. 57, no. 2, pp. 1008–1014, Feb. 2011.
- [40] F. M. J. Willems, “The maximal-error and average-error capacity region of the broadcast channel are identical: A direct proof,” *Probl. Control Inf. Theory*, vol. 19, no. 4, pp. 339–347, 1990.
- [41] M. Langberg and M. Effros, “Network coding: Is zero error always possible?” in *Proc. 49th Ann. Allerton Conf. Comm. Control Comput.*, Monticello, IL, Sep. 2011, pp. 1478–1485.
- [42] R. Stearns, “The voting problem,” *Amer. Math. Monthly*, vol. 66, pp. 761–763, 1959.
- [43] P. Erdős and L. Moser, “On the representation of directed graphs as unions of orderings,” *Publ. Math. Inst. Hungar. Acad. Sci.*, vol. 9, pp. 125–132, 1964.
- [44] E. R. Scheinerman and D. H. Ullman, *Fractional Graph Theory, A Rational Approach to the Theory of Graphs*. New York: Dover Publications, 2011.
- [45] M. Chudnovsky, N. Robertson, P. Seymour, and R. Thomas, “The strong perfect graph theorem,” *Annals of Math.*, vol. 164, pp. 51–229, 2006.
- [46] L. Lovász, “Normal hypergraphs and the perfect graph conjecture,” *Discrete Math.*, vol. 2, pp. 253–267, 1972.
- [47] O. Ore, *Theory of Graphs*. Colloquium Publications, Volume 38, American Mathematical Society, 1962.
- [48] R. Hammack, W. Imrich, and S. Klavzar, *Handbook of Product Graphs, Second Edition*. Boca Raton, Florida: CRC Press, 2011.

- [49] G. Sabidussi, "Graphs with given group and given graph-theoretical properties," *Canad. J. Math.*, vol. 9, pp. 515–525, 1957.
- [50] C. E. Shannon, "The zero error capacity of a noisy channel," *IRE Trans. Inf. Theory*, vol. 2, no. 3, pp. 8–19, Sep. 1956.
- [51] L. Lovász, "On the Shannon capacity of a graph," *IEEE Trans. Inf. Theory*, vol. 25, no. 1, pp. 1–7, 1979.
- [52] M. Grötschel, L. Lovász, and A. Schrijver, "The ellipsoid method and its consequences in combinatorial optimization," *Combinatorica*, vol. 1, no. 2, pp. 169–197, 1981.
- [53] N. Alon, A. Hassidim, E. Lubetzky, U. Stav, and A. Weinstein, "Broadcasting with side information," in *49th Ann. IEEE Symp. Found. Comput. Sci.*, Philadelphia, PA, Oct. 2008, pp. 823–832.
- [54] M. Gadouleau and S. Riis, "Graph-theoretical constructions for graph entropy and network coding based communications," *IEEE Trans. Inf. Theory*, vol. 57, no. 10, pp. 6703–6717, Oct. 2011.
- [55] H. S. Witsenhausen, "The zero-error side information problem and chromatic numbers," *IEEE Trans. Inf. Theory*, vol. 22, no. 5, pp. 592–593, 1976.
- [56] N. Alon and A. Orlitsky, "Source coding and graph entropies," *IEEE Trans. Inf. Theory*, vol. 42, no. 5, pp. 1329–1339, Sep. 1996.
- [57] A. El Gamal and Y.-H. Kim, *Network Information Theory*. Cambridge: Cambridge University Press, 2011.
- [58] Z. Zhang and R. W. Yeung, "On characterization of entropy function via information inequalities," *IEEE Trans. Inf. Theory*, vol. 44, no. 4, pp. 1440–1452, 1998.
- [59] F. Matus, "Infinitely many information inequalities," in *Proc. IEEE Int. Symp. Inf. Theory*, Nice, France, Jun. 2007, pp. 41–44.
- [60] R. Dougherty, C. Freiling, and K. Zeger, "Non-shannon information inequalities in four random variables," 2011. [Online]. Available: <https://arxiv.org/abs/1104.3602>
- [61] K. Shanmugam, A. G. Dimakis, and M. Langberg, "Local graph coloring and index coding," 2013. [Online]. Available: <http://arxiv.org/abs/1301.5359/>
- [62] P. Erdős, Z. Füredi, A. Hajnal, P. Komjáth, V. Rödl, and Á. Seress, "Coloring graphs with locally few colors," *Discrete Math.*, vol. 59, no. 1, pp. 21–34, 1986.

- [63] J. Körner, C. Pillo, and G. Simonyi, “Local chromatic number and Sperner capacity,” *J. Combin. Theory Ser. B*, vol. 95, no. 1, pp. 101–117, 2005.
- [64] M. A. Maddah-Ali, A. S. Motahari, and A. K. Khandani, “Communication over MIMO X channels: Interference alignment, decomposition, and performance analysis,” *IEEE Trans. Inf. Theory*, vol. 54, no. 8, pp. 3457–3470, 2008.
- [65] V. R. Cadambe and S. A. Jafar, “Interference alignment and degrees of freedom of the  $K$ -user interference channel,” *IEEE Trans. Inf. Theory*, vol. 54, no. 8, pp. 3425–3441, Aug. 2008.
- [66] S. A. Jafar, “Topological interference management through index coding,” 2013. [Online]. Available: <http://arxiv.org/abs/1301.3106/>
- [67] T. M. Cover and J. A. Thomas, *Elements of Information Theory*, 2nd ed. New York: Wiley, 2006.
- [68] T. S. Han, “The capacity region of general multiple-access channel with certain correlated sources,” *Inf. Control*, vol. 40, no. 1, pp. 37–60, 1979.
- [69] Y. Liu, P. Sadeghi, F. Arbabjolfaei, and Y.-H. Kim, “On the capacity for distributed index coding,” in *Proc. IEEE Int. Symp. Inf. Theory*, Aachen, Germany, Jun. 2017.
- [70] M. Tahmasbi, A. Shahrabi, and A. Gohari, “Critical graphs in index coding,” in *Proc. IEEE Int. Symp. Inf. Theory*, Honolulu, HI, Jul. 2014, pp. 281–285.
- [71] A. Bachem and W. Kern, *Linear Programming Duality, An Introduction to Oriented Matroids*. Berlin: Springer, 1992.
- [72] L. Ong, “Linear codes are optimal for index-coding instances with five or fewer receivers,” in *Proc. IEEE Int. Symp. Inf. Theory*, Honolulu, HI, Jul. 2014, pp. 491–495.
- [73] R. Belmonte, P. Heggernes, P. v. Hof, A. Rafiey, and R. Saei, “Graph classes and ramsey numbers,” *Discrete Applied Math.*, vol. 173, pp. 16–27, 2014.
- [74] P. Erdős and G. Szekeres, “A combinatorial problem in geometry,” *Compositio Math.*, vol. 2, pp. 463–470, 1935.
- [75] R. Steinberg and C. A. Tovey, “Planar ramsey numbers,” *J. Combin. Theory*, vol. B 59, pp. 288–296, 1993.
- [76] M. M. Matthews and D. P. Sumner, “Longest paths and cycles in  $k_{1,3}$ -free graphs,” *J. Graph Theory*, vol. 9, pp. 269–277, 1985.

- [77] M. Chudnovsky and P. Seymour, “The structure of claw-free graphs,” *Surveys in Combinatorics. London Math. Soc. Lecture Note Ser.*, vol. 327, pp. 153–171, 2005.
- [78] N. Alon and N. Kahale, “Approximating the independence number via the  $\theta$ -function,” *Math. Prog.*, vol. 80, pp. 253–264, 1998.
- [79] K. Appel, W. Haken, and J. Koch, “Every planar map is four colorable—II: Reducibility,” *Illinois J. Math.*, vol. 21, no. 3, pp. 491–567, 1977.
- [80] F. Arbabjolfaei and Y.-H. Kim, “Approximate capacity of index coding for some classes of graphs,” in *Proc. IEEE Int. Symp. Inf. Theory*, Barcelona, Spain, Jun. 2016.
- [81] Y. Berger and M. Langberg, “Index coding with outerplanar side information,” in *Proc. IEEE Int. Symp. Inf. Theory*, Saint Petersburg, Russia, Aug. 2011, pp. 806–810.
- [82] N. B. Shah, K. V. Rashmi, P. V. Kumar, and K. Ramchandran, “Distributed storage codes with repair-by-transfer and nonachievability of interior points on the storage-bandwidth tradeoff,” *IEEE Trans. Inf. Theory*, vol. 58, no. 3, pp. 1837–1852, Mar. 2012.
- [83] D. Papailiopoulos, A. Dimakis, and V. Cadambe, “Repair optimal erasure codes through hadamard designs,” *IEEE Trans. Inf. Theory*, vol. 59, no. 5, pp. 3021–3037, May 2013.
- [84] V. R. Cadambe, S. A. Jafar, H. Maleki, K. Ramchandran, and C. Suh, “Asymptotic interference alignment for optimal repair of mds codes in distributed storage,” *IEEE Trans. Inf. Theory*, vol. 59, no. 5, pp. 2974–2987, May 2013.