

# UC Berkeley

## Research Reports

### Title

Onboard Monitoring and Reporting for Commercial Vehicle Motor Safety

### Permalink

<https://escholarship.org/uc/item/5jc3w34t>

### Authors

Cooper, Doug  
Dickey, Sue  
Johnston, Scott  
et al.

### Publication Date

2007-09-01

CALIFORNIA PATH PROGRAM  
INSTITUTE OF TRANSPORTATION STUDIES  
UNIVERSITY OF CALIFORNIA, BERKELEY

# **Onboard Monitoring and Reporting for Commercial Vehicle Motor Safety**

**Douglas Cooper, et al**

**California PATH Research Report  
UCB-ITS-PRR-2007-15**

This work was performed as part of the California PATH Program of the University of California, in cooperation with the State of California Business, Transportation, and Housing Agency, Department of Transportation, and the United States Department of Transportation, Federal Highway Administration.

The contents of this report reflect the views of the authors who are responsible for the facts and the accuracy of the data presented herein. The contents do not necessarily reflect the official views or policies of the State of California. This report does not constitute a standard, specification, or regulation.

Final Report for Task Orders 5609/6609

September 2007

ISSN 1055-1425



## **Task Order 6609 Final Report:**



# **Onboard Monitoring and Reporting for Commercial Vehicle Motor Safety**

**May 31, 2007**



**Task Order 6609 Final Report**

**Onboard Monitoring and Reporting for Commercial Vehicle Motor  
Safety**

**Authors**

**Doug Cooper**

**Sue Dickey**

**Scott Johnston**

**ZuWhan Kim**

**Thomas Koo**

**Paul Kretz**

**Kenny Kuhn**

**Xiao-Yun Lu**

**JD Margulici**

**James A. Misener (Project Manager)**

**Christopher Nowakowski**

**Jerry Robin (FMCSA)**

**John Spring**

**Martin Walker (FMCSA)**

**Other Team Members**

**Denise Allen**

**Bart Duncil**

**Thang Lian**

**Samer Madanat (Principle Investigator)**

**David Nelson**

**David Ragland**



## **Forward**

This report documents the results of investigation and development of a prototype hardware and software suite that allows for online measurement of a set of driving characteristics which are indicators of unsafe driving behavior. In the work, feedback can be provided to the driver, either directly and in real time, or through carrier management. This allows truck drivers to significantly improve their attentiveness and enhance their safety performance.

In the prototype development work, the monitored parameters and the type of feedback to be given was systematically selected by first examining in the literature commercial vehicle crash causes, and from that, deriving five categories or “core behavioral categories” which as a whole comprise the feature set recommendations for an ideal onboard driver monitoring system. The five monitoring categories or behaviors are listed:

1. Speed Selection
2. Following Behavior
3. Attention (or Inattention)
4. Fatigue
5. General Safety

From this, a prototypical suite was developed, installed and tested on a Class 8 tractor, and a concept for an FOT was developed.

This report will be of interest to anyone interested in the use of onboard monitoring technology in a program to provide a combination of real time and non-real time driver monitoring feedback to enhance safe behaviors for heavy truck and bus drivers.





## **Notice**

This document is disseminated under the sponsorship of the Department of Transportation in the interest of information exchange. The United States Government assumes no liability for its contents or use thereof.

The contents of this report reflect the views of the contractor who is responsible for the accuracy of the data presented herein. The contents do not necessarily reflect the official policy of the Department of Transportation.

This report does not constitute a standard, specification, or regulation.

The United States Government does not endorse products of manufacturers. Trade or manufacturers' names appear herein only because they are considered essential to the object of this document.



## Table of Contents

<b>ABSTRACT</b> .....	<b>XV</b>
<b>KEY WORDS</b> .....	<b>XV</b>
<b>EXECUTIVE SUMMARY</b> .....	<b>XVII</b>
<b>1 Background and Summary</b> .....	<b>1</b>
<b>2 Onboard Monitoring Concept Development</b> .....	<b>6</b>
2.1 DELINEATING CAUSAL FACTORS IN CRASHES .....	7
2.1.1 Introduction.....	7
2.1.2 Safety Issues from the Trucking Industry .....	7
2.1.3 Large Truck Crash Causation Study Emerging Results.....	15
2.1.4 Large Truck Crash Causation Study 2006 Results .....	17
2.1.5 Summary and Relevancy .....	20
2.2 DRIVER BEHAVIOR TASK ANALYSIS .....	23
2.2.1 Method .....	23
2.2.2 Failures Resulting in Driving Over the Lane or Off the Road.....	24
2.2.3 Failures Resulting from Turning at or Crossing an Intersection.....	25
2.2.4 Failures Resulting in Rear-End Collisions.....	27
2.2.5 Other Behavior or Task Failures and Contributing Factors .....	27
2.3 PRINCIPLES TO GUIDE DRIVER MONITORING FEEDBACK .....	29
2.3.1 Overview .....	29
2.3.2 Constituent Tasks of Driving .....	29
2.3.3 What is the Role of Driver Monitoring Feedback?.....	30
2.3.5 When Should Feedback be Given: Immediate or Delayed? .....	32
2.3.6 Should Feedback be Framed as Positive or Negative? .....	32
2.3.7 Feedback Modality.....	33
2.4 ONBOARD MONITORING REVIEW .....	34
2.4.1 Driver Monitoring in the Context of the Behavior-Based Safety Approach ...	34
2.4.2 Driver Monitoring Research Review .....	35
2.4.3 Onboard Monitoring COTS Review.....	37
2.4.3 COTS Summary and Conclusions .....	44
2.5 PROPOSED DRIVER MONITORING TASKS AND METHODS .....	46
2.5.1 Monitoring Vehicle Speed .....	48
2.5.2 Monitoring Following Distance .....	52
2.5.3 Monitoring Attention .....	55
2.5.4 Monitoring Hard Braking Incidents.....	58
2.5.5 Monitoring Lane Position (to include Lane Departure).....	59
2.5.6 Monitoring Lane Changes.....	63
2.5.7 Monitoring and Recording Incidents .....	65
2.5.8 Monitoring Fatigue .....	67
2.5.9 Monitoring Hours of Service .....	71
2.5.10 Monitoring Behaviors at Intersections.....	75
2.5.11 Monitoring Other Vehicle Parameters .....	77



2.6	STAKEHOLDER FEEDBACK .....	80
2.6.1	Group Discussions .....	81
2.6.2	Summary Results and Relevancy.....	89
<b>3</b>	<b>Prototype System .....</b>	<b>103</b>
3.1	OVERVIEW OF OBMS PROTOTYPE IMPLEMENTATION .....	104
3.2	HARDWARE LAYOUT AND OPERATING PRINCIPLES .....	110
3.3	SOFTWARE BUILDING BLOCKS AND INTERFACES .....	117
3.3.1	Software Architecture .....	118
3.3.2	Software for Serial Interface Devices .....	121
3.3.3	Software for Communicating with NAVTEQ ADASRP over Ethernet.....	122
3.3.4	DMM32 Device Driver and Analog and Digital Input Issues .....	123
3.3.5	Video Recording Software.....	124
<b>4</b>	<b>OBMS Functions.....</b>	<b>127</b>
4.1	TRUCK FOLLOWING/STOPPING DISTANCE UNDER VARIABLE CONDITIONS .....	127
4.1.1	Introduction and Motivation .....	127
4.1.2	Vehicle Stopping Distances under Different Conditions.....	129
4.1.3	Front Target Tracking .....	138
4.1.4	Recommended Following Distance .....	143
4.1.5	Recommended Speed.....	144
4.1.6	Preliminary Consideration of Rollover Warning .....	145
4.1.7	Algorithm Implementation.....	152
4.2	FATIGUE AND INATTENTION DETECTION.....	153
4.2.1	Introduction.....	153
4.2.2	Literature Review.....	154
4.2.3	Problem Description .....	159
4.2.4	Driver Fatigue Detection.....	160
4.2.5	Driver Inattention Monitoring.....	163
<b>5</b>	<b>Onboard Monitoring Performance .....</b>	<b>171</b>
5.1	DRIVER FEEDBACK.....	171
5.1.1	Overview .....	171
5.1.2	Monitoring Speed: Intelligent Speed Adaptation (ISA) .....	172
5.1.3	Monitoring Following Behavior .....	175
5.1.4	Monitoring Attention and Fatigue .....	178
	Figure 5-3. COTS SafeTRAC Lane Departure Warning System DVI.....	180
5.1.5	Monitoring Good Driving Safety Practice .....	182
5.1.6	Off-Line Feedback and Reporting .....	184
5.1.7	Incident Recording and Review .....	185
<b>6</b>	<b>FOT Planning.....</b>	<b>188</b>
<b>7</b>	<b>Summary and Conclusions.....</b>	<b>191</b>



<b>Appendix A: Systems Engineering Process and Chronology .....</b>	<b>A1</b>
A.1 INTEGRATION .....	A1
A.2 CONFIGURATION MANAGEMENT .....	A4
A.3 VERIFICATION .....	A5
A.4 RISK MANAGEMENT .....	A7
<b>Appendix B: Systems Engineering Management Plan .....</b>	<b>B1</b>
<b>Appendix C. Systems Requirements Document.....</b>	<b>C1</b>





## **Abstract**

This final report describes the process and product from the project, *Onboard Monitoring and Reporting for Commercial Motor Vehicle Safety (OBMS)*, in which a prototypical suite of hardware on a Freightliner Century Class truck was developed and tested.

The OBMS suite allows for online measurement of a set of driving characteristics which are indicators of unsafe driving behavior. These characteristics include speed, following distance, lane keeping performance, safety belt use, and the use of turn signals. Feedback can be provided to the driver, either directly via real time feedback or through carrier management, to allow drivers to significantly improve their safety performance. For example, if a driver receives a report that he/she is not using his/her turn signals during lane changes, that driver can then be monitored during a follow up period to determine if feedback had corrected the deficiency. This concept would be pioneered in commercial fleets because they have the resources and organizational structure to provide feedback and training to professional drivers. This concept differs from commercial onboard devices in that it is an ensemble set of instruments – not one or a few warning devices – with a safety focus and different feedback modalities. It is comprehensive in that it addresses crash causes and provides ‘corrective’ feedback in real time and/or post-trip feedback, depending on the particular subsystem(s) which are activated. In essence, the objective is to improve and maintain driver safety behaviors. Thus, it does not explicitly address fleet management or other non-safety operations, for example vehicle location and tracking or fuel economy.

A systems engineering process was applied to this research, resulting in a prototypical OBMS hardware suite and a plan to follow up this effort with a FOT. This project is the result of a Federal Motor Carrier Safety Administration Cooperative Agreement with Caltrans, it was undertaken by the California Partners for Advanced Transit and Highways (PATH) program, with assistance from the California Center for Innovative Transportation (CCIT) and a subcontractor, Advanced Systems Engineering Consulting.

## **Key Words**

Onboard Monitoring, Commercial Motor Vehicle, Driver Safety, FOT, Electronic On-Board Recorder, Hours of Service, Lane Departure Warning Systems.



## **Executive Summary**

Each year over 450,000 large trucks are involved in crashes, resulting in about 5000 fatalities and 120,000 injuries according to the most recent compilation of traffic safety facts released by the National Highway Traffic Safety Administration (NHTSA). Overall, crashes involving large trucks comprise 4.1 percent of all crashes, but they also contribute to 12 percent of all fatalities (or one out of every nine). Furthermore, more than 85 percent of the time, the fatality was not an occupant of the truck (NHTSA, 2003). These numbers underscore why a reduction of commercial motor vehicle (CMV) crashes is an essential element of highway safety. Granted, in 71-percent of truck-involved crashes with multiple vehicles, police assign error to passenger vehicle drivers. However, CMV driver error is still a major causal factor to truck-involved crashes. Consider that:

- Almost 30-percent of large truck drivers involved in fatal crashes had at least one prior conviction for speeding, compared to slightly less than 20-percent of the passenger vehicle drivers in fatal crashes.
- A loaded tractor-trailer requires 20-40-percent further stopping distance than a car. This situation is worsened with downgrades and wet pavement.
- Crashes involving trucks are more likely to involve a serious injuries or fatalities than are crashes involving only passenger vehicles.
- Over the past 10 years (1992 to 2002) there has been a 31 percent increase in registered large trucks and a 40-percent increase in miles traveled by large trucks.

Driver performance may be improved through CMV Onboard monitoring systems, coupled with appropriate feedback to the driver. Onboard monitoring may provide a mechanism to encourage good driving behavior by recognizing and correcting self-induced hazardous driving situations.

This is the basis for a Federal Motor Carrier Safety Administration Cooperative Agreement with Caltrans, which has turned into an active University of California, Berkeley Partners for Advanced Transit and Highways project (with California Center for Innovative Transportation assistance, particularly in the area of systems engineering), *Onboard Monitoring and Reporting for Commercial Motor Vehicle Safety* (OBMS).

The OBMS project has produced a prototypical suite of hardware on a Freightliner Century Class truck at the Richmond Field Station, shown in Figure 0-1 below.



**Figure 0-1. Vehicle Used for OBMS Prototype Integration**

The hardware suite allows for online measurement of a set of driving characteristics which are indicators of unsafe driving behavior. These characteristics include speed, following distance, lane keeping performance, safety belt use, and the use of turn signals. Feedback can be provided to the driver, either directly and in real time, or through carrier management, which would allow drivers to significantly improve their safety performance. For example, if a driver receives a report that he/she is not using his/her turn signals during lane changes, that driver can then be monitored during a follow up period to determine if feedback had corrected the deficiency. This concept would be pioneered in commercial fleets because they have the resources and organizational structure to provide feedback and training to professional drivers.

In the OBMS prototype development work, the monitored parameters and the type of feedback to be given was systematically examined by first examining commercial vehicle crash causes, and from that, deriving five categories or “core behavioral categories” which as a whole comprise the feature set recommendations for an ideal onboard driver monitoring system. The five monitoring categories or behaviors are listed below:

1. Speed Selection
2. Following Behavior
3. Attention (or Inattention)
4. Fatigue
5. General Safety

From examination of these categories and by synthesizing literature examined (and reported) during the course of this project, specific monitoring methods, parameters and feedback were determined, and a prototype suite was developed. Table 0-1 below summarizes the suite by mapping classes of monitored behavior to specific application descriptors and the type of real time feedback provided. All behaviors exceeding threshold values are fed back to the driver and reported to the carrier.

**Table 0-1. Summary of OBMS Suite: Functions, Monitored Elements, Feedback**

Core Behavioral Categories	Potential Behaviors/Parameters to be Monitored	Required Sensors or Subsystems	Potential Driver Feedback	
			Real-Time	Off-Line (Delayed)
<b>1. Speed Selection</b>	Speed vs. - Speed Limit - Traffic Flow - Curve Speed - Road Surface - Grade	Vehicle Jbus Access GPS Database of Speed Limits Road Surface/Weather Radar or Lidar Accelerometer	Visual feedback of recommended and maximum speed limits	Summary metrics such as the time spent over the recommended and maximum speed limits
<b>2. Following Behavior</b>	Following Distance Forward Collision Warnings Driver response to Cut-ins	Forward Collision Warning System (FCW) Radar or Lidar Video Recording	Visual feedback of following time-gap shown  Auditory alerts for following too close and approaching too fast	Summary of time spent following too close, # of warning incidents, video review of warning incidents
<b>3. Attention (or Inattention)</b>	Road/Lane Departures Hard Braking Events Hard Steering Events Eye-Off-The-Road	Road Departure Warning System (RDWS or LDWS) Accelerometer Steering Angle Steering Gyro Video Recording Eye/Face Tracking	Visual and auditory alerts of lane departures or eyes-off-the-road for too long	Summary metrics such as the frequency of lane departures, hard braking, and hard steering incidents
<b>4. Fatigue</b>	Road/Lane Departures Lane Position Keeping Hard Braking Events Hard Steering Events Eye Closure (PERCLOS) Hours of Service (HOS) Compliance	RDWS / LDWS Eye Tracking Accelerometer Steering Angle Steering Gyro Video Recording EOBR (Electronic On-Board Recorder for HOS)	Visual and auditory alerts of lane departures, lane weaving, eye closure, and HOS compliance	Summary metrics such as the frequency of lane departures, hard braking, hard steering incidents, and HOS compliance
<b>5. General Safety</b>	Safety Belt Use Lane Change Turn Signal Use Lane Change Blind Spot Check Proper Mirror Adjustment Fuel Economy Engine Overspeed (RPMs) Acceleration Deceleration (Downshifting) Gear selection on grades	Safety Belt Monitor Video Recording RDWS / LDWS Eye/Face Tracking Accelerometer Vehicle Jbus Access Misc. Wire Taps	Visual and auditory alerts if safety belt is not use  Visual feedback on other parameters	Summary metrics such as time spent using the safety belt and the other listed parameters

For the OBMS prototype, if feedback is supplied by a Commercial Off The Shelf (COTS) system, that feedback is kept. Additional feedback is provided via audio channel and via surrogate instrument cluster displayed in a 7-inch LCD screen, as illustrated in Figure 0-2. In that figure,

the suggested speed limit for the given road surface and curvature is the portion of the circular speedometer gauge not outlined in red. The suggested safe following distance feedback, again provided that the prevailing road surface condition (and for this function, by the sensed ‘field’ of other forward vehicles), is the color and size of the vehicle shown at the bottom of the surrogate cluster. In this instance, the vehicle is colored green; when following too closely for prevailing conditions, the vehicle changes to yellow, then red and grows or looms. Also, beneath the green vehicle icon is the car following gap, given in seconds. Finally, the “driver ID”, “HOS [hours of service] remaining” and “Alertness Index” are also provided as direct feedback of a prototypical digital tachometer and also a drowsiness/alertness warning which supplements that subsystem’s COTS-based feedback.



**Figure 0-2. Depiction of OBMS Driver Feedback**

Figure 0-3 diagrams the prototype OBMS, which consists of six subsystems:

- Core system
- Sensing equipment
- Data storage devices
- Real-time feedback devices
- Driver input devices



- Offline analysis tools.

In the figure, sensors (1) input to the Onboard Processor (2), which output to Data Storage (3) and Analysis Modules (4). Driver Interfaces (5) also interact with the Onboard Processor. Additionally, Hardware Mounts and Cables (6) interact with all but the Analysis Module. The Analysis Module is off-board and all other subsystems are on-board.

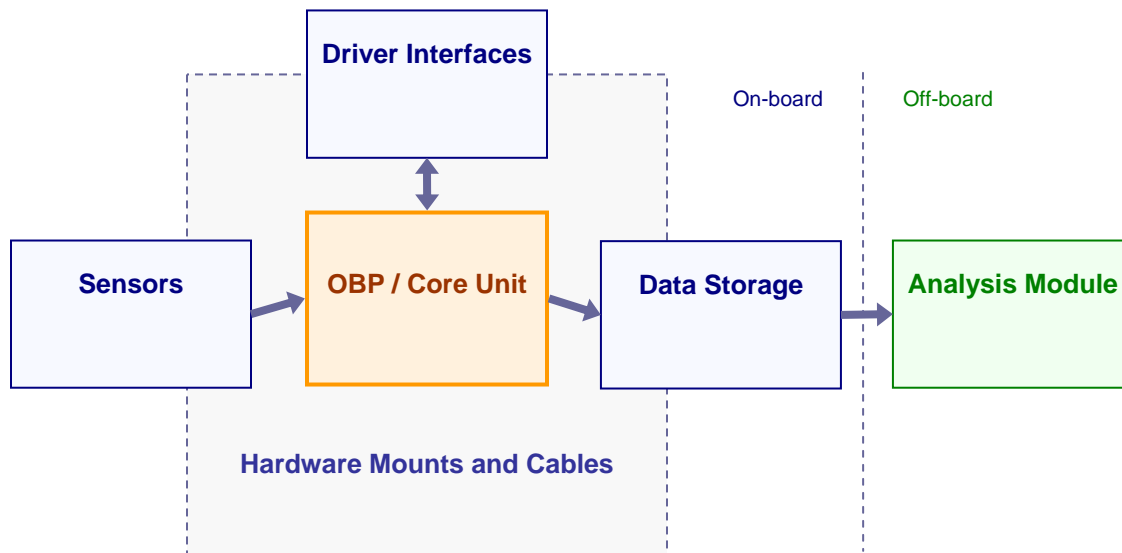

**Figure 0-3. The Six Subsystems of the Onboard Monitoring System are Shown.**

This prototype was developed along systems engineering principles, and specifically, via the Vee Diagram methodology. This entailed development and use of a ConOps (ConOps)-derived set of requirements which defines the OBMS.

The background, data sources, tradeoff considerations, description of the hardware, software and applications of the OBMS – plus a description of a notional FOT – are discussed in detail within this report and its appendices.

We have worked with a Los Angeles-based fleet of 100 drivers to determine the suitability of this hardware suite to the firm’s management and truckers. In FY08 the contractor will work

with the sponsoring agencies and a different, larger fleet to conduct a FOT to replicate this suite on a host of other vehicles and determine the technical and operational effectiveness of the OBMS suite of monitoring systems.



## **1 BACKGROUND AND SUMMARY**

Each year over 450,000 large trucks are involved in crashes resulting in about 5000 fatalities and 120,000 injuries according to the most recent compilation of traffic safety facts released by the National Highway Traffic Safety Administration (NHTSA). Overall, crashes involving large trucks comprise 4.1 percent of all crashes, but they also contribute to 12 percent of all fatalities (or one out of every nine). Due to the size and mass differential, more than 85 percent of the time, the fatality was not an occupant of the truck (NHTSA, 2003).

The general case for truck driver monitoring in the trucking industry has already been made through research sponsored by the Federal Motor Carrier Safety Administration (FMCSA) and is best summarized in a technical brief (Behavioral Science and Technology, Inc., 2000). In its most simplistic form, the behavior-based safety approach is a method for improving safety, by which, behaviors critical to safety are identified and monitored. Safe behavior is rewarded and unsafe behavior is discouraged and improved upon, thereby proactively improving overall safety.

In Section 3 of this report, three types of studies will be presented on the topic of delineating the causal factors in large truck crashes: expert interviews, reviews of crash statistics, and the Large Truck Crash Causation Study (LTCCS). Although, all of these sources had both advantages and disadvantages, the LTCCS (Craft and Blower, 2004) suggested three general categories of critical events leading to crashes that could be considered high priority: (1) driving over the lane markings or off the road, (2) turning at or crossing an intersection, and (3) rear-end collisions. The most common reasons for the critical event were driver errors in recognitions (due to inattention or distraction) and errors in decisions (misjudgments). In support of this assertion, the industry experts, truck drivers, fleet managers, and safety experts, all agreed that the inattention and distraction are major problems which need to be addressed. Furthermore, according to surveys, fleet managers often estimate that their worst 10 percent of drivers account for up to 50 percent of their fleet risk, and this estimate was supported in a critical incident analysis of the instrumented vehicles (Knipling 2005). In this study the worst 6 drivers, accounting for only 12 percent of the driving time, were responsible for 38 percent of the critical incidents. In contrast, the best 25 drivers, accounting for 63 percent of the driving time, were

only responsible for 16 percent of the critical incidents. Onboard driver monitoring and feedback may be one way to objectively identify high risk drivers, and help them to curb risky driving behavior.

Also as discussed in an earlier project report, the concept onboard driver monitoring comes from the behavior-based safety approach. Using this method, safe behavior is rewarded and unsafe behavior is discouraged and improved upon, thereby proactively improving overall safety. Implementing an onboard driver-monitoring behavior-based safety approach generally requires four steps (Sherry, 2001):

1. Identify behaviors which may be precursors to increased crash rates.
2. Determine cost-effective ways to monitor safe and unsafe behaviors.
3. Determine the best way to provide the driver with feedback which rewards safe behavior and discourages unsafe behavior.
4. Establish management and driver acceptance to the program.

These four steps constitute the fundamental basis or philosophy of OBMS. The pragmatic or implementation dimension was built upon this and consumed approximately 80% of the time and resources of the project. Driven by necessity since the project scope was ambitious – to research the aforementioned elements of an OBMS system then, on a fast track, develop a prototype *and* set the stage for a FOT, the project was tailored to and performed with the principles of Systems Engineering. The nomograph shown in Figure 1.1 illustrates the project tasks, conducted along the left side then down the vertex of the “Vee Diagram”, then up through the horizontal dashed line, low speed testing in the environs of the PATH facility of the Richmond Field Station, to include public roads outside the premises. The OBMS-customized Vee-diagram illustrated in Figure 1.1 consists of Planning, Causal Study, Requirements and ConOps (ConOps), Requirements and System Architecture and Detailed Design on the downward-pointing segment of the diagram. The vertex consists of software coding and hardware fabrication. The upward-pointing segment of the diagram is the Software-Hardware Evaluation (stemming from the

Detailed Design and bridged by a Verification Plan), System Evaluation (stemming from the ConOps and Requirements and bridged by the System Acceptance Plan), and finally the Phase 2 or next project FOT (stemming from Planning and bridged by the Field Operation Evaluation). At each of these major elements is a decision gate.

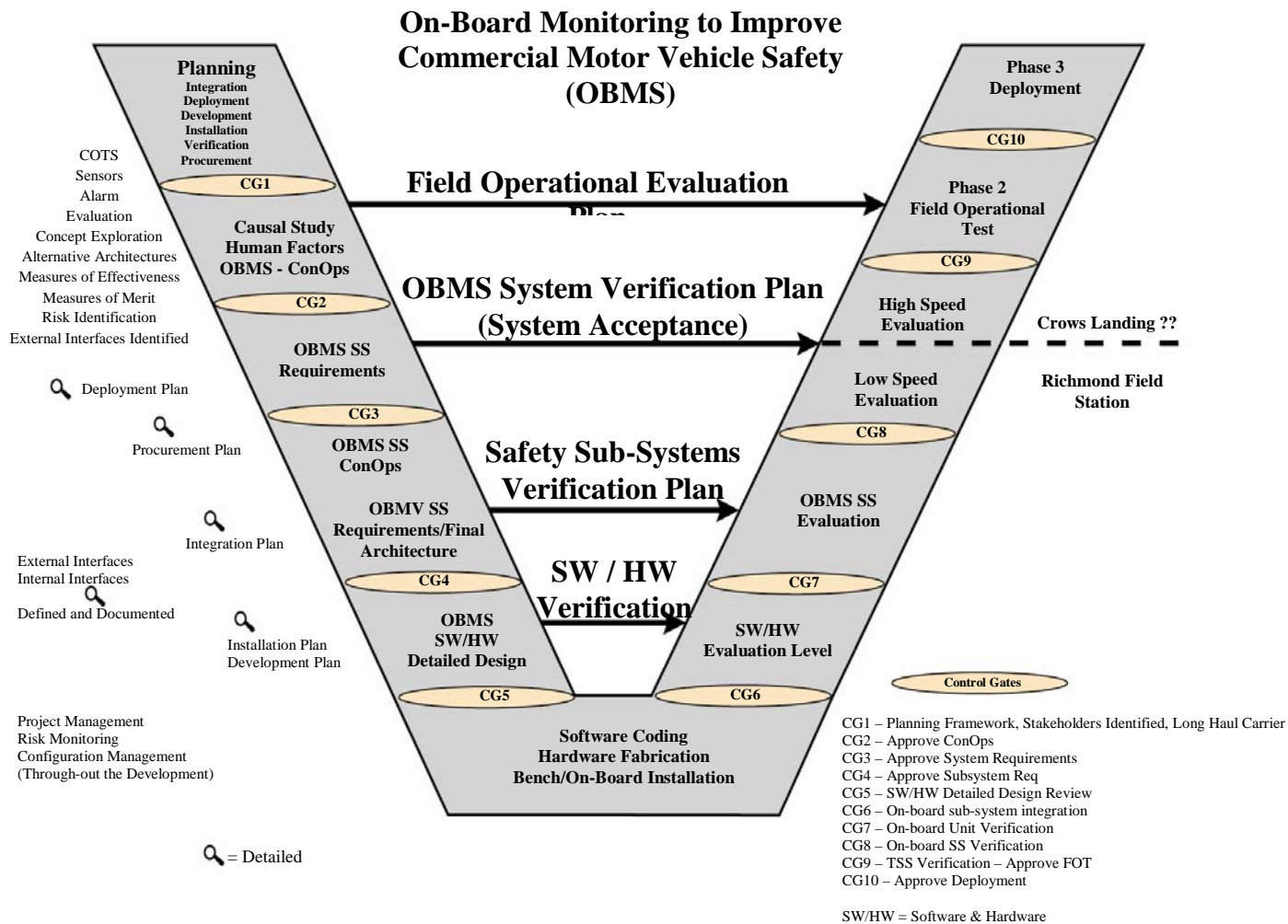

**Figure 1-1. Project Vee Diagram**

This project is structured to reflect the logical sequence of the work performed. The project results are described chronologically, beginning with **Section 2.0 (Concept Development)**. This section describes driver behavior, functional needs and product background that formed the project ConOps. This section is particularly important as the content therein forms the basis for the requirements and actual implementation of the OBMS system.

The resulting hardware and software that constitute the prototype OBMS is described in **Section 3.0 (OBMS Suite)**. This is followed by **Section 4.0 (OBMS Functions)**, which describe some of the PATH-developed algorithms and applications that leverage the existent hardware. How the interface to the driver and system inputs work is described in **Section 5.0 (OBMS Performance)**.

An activity begun about midway through the project was to co-develop a FOT plan with a commercial carrier. **Section 6.0 (FOT Planning)** briefly describes the process and next steps, then details a notional FOT Statement of Work that was developed in the time frame of this project.

Finally, **Section 7.0 (Summary and Conclusions)** provides a summary of the project vis-à-vis initial objectives and outlines a set of recommended further activities.

#### **References (Section 1.0):**

Craft, R. and Blower, D. (2004). An Overview of the Large Truck Crash Causation Study. A Presentation Given at The 3<sup>rd</sup> Annual Stakeholder's Forum on November 30<sup>th</sup> in Phoenix, Arizona. Washington, D.C.: The Federal Motor Carrier Safety Administration's Office of Research and Technology.

Knipling, R. (2005). Evidence and Dimensions of Commercial Driver Differential Crash Risk. Proceedings of the Third International Driving Symposium on Human Factors in Driving Assessment, Training, and Vehicle Design. pp. 2-8.

National Highway Traffic Safety Administration (2003). Traffic Safety Facts 2003: A Compilation of Motor Vehicle Crash Data from the Fatality Analysis Reporting System and the General Estimates System (DOT HS 809 775 and DOT HS 809 763). Washington, DC: National Center for Statistics and Analysis. [<http://www.nhtsa.dot.gov/people/ncsa>]

Sherry, P. (2001). In-Vehicle Monitoring Technologies: Review of Current Use and Potential Enhancement Through Behaviorally Based Safety Processes (Report Submitted to the American Trucking Association Foundation). Denver, CO: The University of Denver.



## **2 ONBOARD MONITORING CONCEPT DEVELOPMENT**

This section provides background on the topic of onboard driver monitoring systems for use in commercial heavy vehicles and serves as a basis for the suite used on the prototype system developed for this project. First and to reiterate, the purpose of this project was to develop a ConOps and a required sensor suite for an ideal driver monitoring system which would help to improve fleet safety. These were developed based on information gathered from the industry and on previous research as summarized here. Furthermore, an expert group of professional drivers and an advisory panel of industry experts and practitioners reviewed and supplemented the findings of these reports. This section is divided into six subsections:

1. Delineating Causal Factors in Crashes
2. Driver Behavior Task Analysis
3. Principles of Driver Monitoring Feedback
4. Onboard Monitoring Review
5. Proposed Driver Monitoring Tasks and Methods
6. Stakeholder Feedback

These subsections build upon one another, with the first subsection providing a literature-based foundation on what causes truck driver crashes (to include reports and papers from recent FMCSA-sponsored research) and the second subsection breaking driver crash causes down further into specific tasks. On top of these sections is the third subsection (Principles of Driver Monitoring Feedback), which overlays onto the previous two sections a fundamental philosophy and approach. Given a fourth subsection (Onboard Monitoring Review), the fifth subsection (Proposed Driver Monitoring Tasks and Methods) is presented, where specific and objective OBMS measures are suggested, and short descriptions of COTS devices, as they existed at the time of the project's review, are provided. Lastly, stakeholder feedback – in the form of expert interviews with a mid-size Los Angeles-based carriers – is covered. It is the combination of

these factors and COTS devices, combined via the systems approach, that led to decision and installation of the suite of OBMS hardware described in Section 4.0.

## **2.1 Delineating Causal Factors in Crashes**

### **2.1.1 Introduction**

Historically, three methods have commonly been employed to approach the problem of heavy vehicle crash causation. First, panels of drivers or experts have been consulted come up with lists of safety issues in the trucking industry and “unsafe” driving behaviors. While these methods are completely subjective, they are based on drivers’ experiences and often provide a useful perspective.

Second, many studies have mined the crash statistics associated with large trucks with some success. Unfortunately, crash reports, as currently recorded in the United States, are often vague and lacking in important details, and thus, do not necessarily reflect or contain the true causes of a crash. Additionally, many of past studies which are reviewed in this section have tried to categorize or examine crashes in terms of “fault”, which is a fairly subjective designation and should be read as such.

In response to these sorts of issues, a third approach, the Large Truck Crash Causation Study (LTCCS), addresses the problem with a more robust perspective and method. Instead of trying to determine “cause” or “fault” directly, the LTCCS addresses “cause” in terms of critical events, critical errors that lead to those events, and contributing factors.

### **2.1.2 Safety Issues from the Trucking Industry**

#### Studies in the U.S.

In 2003, the first in a series of TRB reports on Commercial Truck and Bus Safety was published. In this report (Knippling, Hickman, and Bergoffen, 2003) surveyed commercial motor vehicle (CMV) fleet managers and experts in motor vehicle safety on importance of 20 perceived safety problem areas in the trucking industry. The top 9 issues that were found are listed below:

1. At-risk driving behaviors (e.g., speeding, tailgating)
2. Individual high-risk drivers (all causes combined)
3. Lifestyle or general health issues (e.g., poor diet, smoking)
4. Lack of defensive driving skills (poor space management)
5. Delays associated with loading and unloading cargo
6. Driver fatigue/drowsiness
7. Aggressive driving
8. Heart Disease
9. Poor attitude, morale, emotional state

Of these nine issues, at risk driving behaviors, defensive driving skills, fatigue, and aggressive driving are all potential candidates for an onboard monitoring system. Although aggressive driving could not be specifically defined, the report went on to define the following as at-risk driving behaviors (many based upon prior studies and crash data):

- Speeding
- Excessive speed on curves or in relation to weather conditions
- Improper following distance
- Lateral encroachment (e.g., during lane changes, due to improper mirror adjustment)
- Failure to yield at intersection
- General disobedience of the rules-of-the-road

The specifics of space management and defensive driving skills were left somewhat undefined. The general concept of space management refers to the fact that large trucks have large blind spots and limited maneuverability when reacting to actions taken by automobile drivers. In effect, space management refers to the need for truck drivers to preventively compensate for any poor decisions being made in their presence because many crashes between trucks and automobiles tend to be primarily attributed to the actions of the automobile driver.

Finally, the Knipling, Hickman, and Bergoffen (2003) reported provided a good discussion on the issue of fatigue. While it had been widely reported that fatigue was a large problem and a

factor in 31 percent of single-vehicle ran-off-the-road crashes where the truck driver was killed, this particular crash type only accounts for 1 in 7 fatal truck crashes and 1 in 700 overall truck crashes. Thus, when considering truck crashes overall, the issue of fatigue is ranked as a somewhat lower priority and possibly one that is limited mostly to specific segments of the trucking industry.

While the study described above interviewed fleet managers and safety experts, two recent studies surveyed truck drivers about their safety concerns. Hanowski, et. al. (1998) conducted 11 focus groups across 5 states with a total of 82 local and short haul (L/SH) truck drivers. Across all sessions, the top five critical issues or crash causal factors as seen by drivers were as follows (ranked in order of importance to the drivers):

1. Problems caused by drivers of light vehicles
2. Stress due to time pressure
3. Inattention
4. Problems caused by roadway or dock design
5. Fatigue

The problems caused by the drivers of light vehicles, although ranked as the most important safety issue, was generally described in vague terms, such as light vehicle drivers do not show trucks enough respect. Specifically, cut-ins and backing were listed as problems with light vehicles. Interestingly, inattention was listed as one of the top five safety issues by drivers in this study, but there was no mention of it by management in the previous study. However, inattention, in the context of L/SH drivers, seemed to refer to the issues of multitasking while driving, such as planning your next stop or delivery or having to navigate with ineffective road signage. Similarly, fatigue, in the eyes of L/SH drivers, was used more in the context of mental fatigue as opposed to actually falling asleep at the wheel. Since L/SH drivers tend to work during daylight hours and have frequent breaks (deliveries) to interrupt their driving, fatigue is simply the result of a normal day's work, which can be exacerbated by excessive heat (a lack of A/C in their vehicles) or irregular meal times.

Finally, Roetting, Huang, and McDevitt (2005) surveyed 239 long and short haul drivers specifically asking them to rank the importance of several critical safety behaviors. The drivers were presented with ten behaviors and asked to select their top three. The results are shown below in Table 2-1, which maps critical safety behaviors or issues by percentage of drivers ranking them in their “top three”.

**Table 2-1. Critical Safety Behaviors or Issues**

<b>Rank</b>	<b>Critical Safety Behaviors or Issues</b>	<b>% of Drivers Ranking in their “Top 3”</b>
1	Looking far enough ahead and anticipating changes	74.4
2	Being ready to avoid the mistakes of other drivers	55.4
3	Turn signal use in advance of lane changes	48.7
4	Properly adjusting mirrors to prevent blind spots	29.2
5	Drowsy driving	28.2
6	Speeding	17.4
7	Seatbelt usage	16.4
8	Following too close	13.3
9	Distracting driving	8.7
10	Being courteous to other drivers	8.7

International Studies

In New Zealand, Sullman, Meadows, and Pajo (2002) surveyed 382 truck drivers on the topic of aberrant driving behaviors falling into 3 categories:

1. Errors
2. Lapses
3. Violations

Errors included such things as failures of observation and misjudgments, e.g., braking too hard on a slippery road. Lapses were considered as failures of attention, and violations were deliberate actions such as speeding or tailgating. The questionnaire asked drivers to self-report on a scale of 0 (never) to 5 (all the time) how often they engaged in or experienced a particular behavior. Of the three categories, only responses to the questions on violations were predictive of increased crash risk. The most commonly reported behaviors in each category (those with a

mean score above 0.5) are listed below in Table 2-2, comprised of columns categorizing errors as “lapses”, “violations” or “aggressive driving”.

**Table 2-2. Most Common Self-reported Aberrant Driving Behaviors in New Zealand**

<b>Errors</b>	<b>Lapses</b>	<b>Violations</b>	<b>Aggressive Driving</b>
Underestimating the speed on an oncoming vehicle while overtaking	Getting into the wrong lane at a junction	Speeding	Honking at others
	Having no recollection of the road you just traveled	Tailgating	Showing hostility
	Hitting the wrong control in the vehicle	Running a red light	Racing away from a traffic light
	Starting in the wrong gear		
Backing into an object			

In Finland, Häkkänen and Summala (2001) surveyed 251 long-haul drivers, asking them to rank 8 safety issues from the most common to the least common cause of crashes. The results are listed below in rank order from most to least common:

1. Other road users
2. Errors in truck driver perception or judgment
3. Speeding
4. Weather
5. Fatigue
6. Errors in operating the vehicle
7. Traffic environment
8. Technology faults

Unfortunately, greater detail on what was meant specifically by errors in perception or judgment or errors in operating the vehicle was not available. However, the country of Finland is somewhat unique in that every fatal crash involving large trucks has been investigated by a panel of experts to determine what factors were relevant in the cause of the crash. From 1991 to 1997, it was found that in 83 percent of the crashes involving large trucks, the truck driver was not

primarily at fault. Similar to the U.S. conclusions, this evidence supports the truck drivers' view that other road users are the most common cause of crashes. In the 17 percent of crashes where the truck driver was primarily at fault, the breakdown by crash type is listed below in Table 2-3, which ranks fatal crash types by percentage.

**Table 2-3. Fatal Crash Type Distribution when the Truck Driver was Primarily Responsible**

<b>Rank</b>	<b>Crash Type</b>	<b>%</b>
1	Opposite direction or head-on collision	50.9
2	Same direction (overtaking, change of lane or rear-end collision)	17.5
3	Same direction with one vehicle turning	10.5
4	Intersection straight crossing path	8.8
5	Intersection with one vehicle turning into or across path	5.3
-	Opposite direction with one vehicle turning	0.0
-	Other	7.0
<b>Total</b>		<b>100.0</b>

The high prevalence of opposite direction head-on collisions is probably due to the fact that most of the roads traversed by trucks in Finland are two-lane highways. A different crash type distribution would probably be expected in the U.S. where multi-lane freeways are more common. In addition to determining which driver was primarily at fault, the panel of experts also made determinations about casual factors. Table 2-4 shows the percentage of crashes attributed to each causal factor. Over 50 percent of the fatal truck crashes where the truck driver was primarily at fault were attributed to errors in attention, anticipation, or estimation, and 26 percent were attributed to errors in operating the vehicle. Unfortunately, specific details were not given on these two classifications.

**Table 2-4. Fatal Crash Casual Factors when the Truck Driver was Primarily Responsible**

<b>Rank</b>	<b>Causal Factor</b>	<b>%</b>
1	Error in attention, anticipation or estimation	50.8
2	Error in operating the vehicle	26.3
3	Technological faults	7.0
4	Driver having fallen asleep while driving	5.3
5	Attack of illness	1.8
6	Traffic environment	1.8
-	Other reasons	7.0
Total		100.0

U.S. Crash Statistics

There have been numerous studies employing various methods to analyze the crash statistics when large trucks are involved. In the United States, the Center for National Truck and Bus Statistics at the University of Michigan Transportation Research Institute (UMTRI) publishes a yearly Trucks Involved in Fatal Accidents Factbook, which combines data from the Fatality Analysis Reporting System (FARS) with follow-up surveys. From the latest factbook (Matteson, Blower, and Woodruffe, 2004), Table 2-5 summarizes the types of fatal crashes in which trucks are typically involved in showing by crash type whether the truck was striking or whether another vehicle was striking. It is interesting to note that when it comes to fatal crashes, the percentage of crashes is fairly evenly distributed among crash types. The largest single category of crash type involvement is single vehicle, either ran-off-the-road or hit an object in the road. The second largest category was rear end collisions, with the truck being the striking vehicle 38 percent of the time. Interestingly, for sideswipe and head-on collisions, the crashes typically occurred with the other vehicle striking the truck or in the truck's lane. However, for straight crossing path collisions (at intersections), the truck typically did the striking, which is probably a reflection of the well known rural crash paradigm where light vehicle drivers pull out in front of an oncoming truck having misjudged the truck's distance and speed.



**Table 2-5. Trucks Involved in Fatal Crashes by Crash Type**

<b>Crash Type</b>	<b>Truck Striking (In Other Vehicle's Lane)</b>	<b>Other Vehicle Striking (In Truck's Lane)</b>	<b>Total (%)</b>
Single Vehicle	-	-	14.4
Rear End	5.1	8.2	13.3
Sideswipe	2.2	10.2	12.4
Intersection (Straight Crossing)	8.0	3.2	11.2
Head-on	1.1	9.2	10.3
Intersection (Across Path Turn)	-	-	9.2
Backing	0.5	0.1	0.6
Other			15.5
Unknown			13.2
<b>Total</b>			<b>100</b>

Another important study, Council, Harkey, Nabors, Khattak, and Mohamedshah (2003), examined the North Carolina crash database from 1994 to 1997 which included 16,264 car-truck crashes. Although this database is not national, it includes all crashes, not just fatal crashes. What is most interesting to note is that while national studies of fatal truck crashes have shown that car drivers were considered “at fault” for the crash almost 70 percent of the time, truck drivers may share more of the blame when it comes to overall or non-fatal crashes. As shown in Table 2-6’s distribution of truck at fault vs. car at fault by crash type, Council et al. (2003) found that overall, fault was more evenly split with 48 percent of crashes being attributed to the truck driver and 40.2 percent being attributed to the car driver (with the remaining being attributed to both or neither).

**Table 2-6. Fault Distribution of Crash Types**

<b>Crash Type</b>	<b>% Truck “at Fault”</b>	<b>% Car “at Fault”</b>	<b>Total %</b>
Rear-end (slow)	50.7	41.0	25.8
Rear-end (turning)	51.5	36.0	2.4
Left turn (same roadway)	45.4	38.6	8.7
Left turn (crossing traffic)	42.9	48.4	5.9
Right turn (same roadway)	43.1	35.5	4.7
Right turn (crossing traffic)	36.2	54.4	2.3
Head-on	22.5	71.2	1.4
Sideswipe	51.1	35.1	21.8
Angle	39.3	48.5	21.4
Backing	81.5	9.7	5.5
Total	48.0	40.2	100.0

Interestingly, most of the crash types show a fairly even split between car and truck drivers, however, there were several crash types with large disparities. Crashes that involved backing or rear-end crashes while turning were much more often the fault of the truck driver, although these two categories accounted for only 7.9 percent of the overall crashes. The largest overall category where truck drivers were most at fault was in sideswipe crashes which account for 21.8 percent. Although a detailed description was not given for this crash type, process of elimination would suggest that the authors are referring to intersection straight crossing path collisions.

### **2.1.3 Large Truck Crash Causation Study Emerging Results**

Recognizing that surveys of truck drivers and industry experts and crash statistics as currently gathered have flaws, perhaps the most definitive work which will come on the topic of truck crashes is the Large Truck Crash Causation Study (LTCCS). This joint study between FMCSA and NHTSA was in progress at the time of this was examined in the OBMS study. An interim report on the project status (Blower and Campbell, 2002) laid out the methodology for the study. The study was seeking to build a national sample of over 1000 fatal and serious injury crashes with supplemental information gathered to allow the coding of a critical event, a critical reason for the critical event, and other crash related factors. The critical event is defined as the action or event that put the vehicles on a collision course. The critical reason is defined as the immediate reason for the critical event.

The distribution of critical events for two-vehicle crashes (between trucks or other vehicles and indexed by the critical event in two-vehicle crashes) is detailed in Table 2-7 based on presentation of the LTCCS interim results (Craft and Blower, 2004). At the time of this was examined in the OBMS development, the LTCCS had only examined 589 raw crash samples and only 287 of those crashes were two-vehicle crashes between a car and a truck. The largest three categories of critical events (almost 80 percent of the crashes) included driving out of the lane, turning at or crossing intersections, and rear-end crashes.

**Table 2-7. LTCCS Critical Events by Vehicle Exhibiting the Critical Event**

<b>Critical Event (for two-vehicle crashes)</b>	<b>Truck (%)</b>	<b>Other Vehicle (%)</b>	<b>Total Crashes (%)</b>
Vehicle	1	1	1
Roadway or environment	0	3	2
Loss of control (driving too fast)	3	10	8
Driving over the lane or off the road (including head-on and lane change)	35	29	30
Turning at or crossing an intersection	27	28	28
Same lane (rear-end)	28	27	26
Other	8	3	5
Total	100	100	100

Although the results in Table 2-7 somewhat resemble past studies detailing crash type by fault, the power of the LTCCS is in the fact that it goes beyond just crash type. As shown in Table 2-8, the critical reasons and distribution between trucks and other vehicles for the critical events are shown for the same two-vehicle crashes described in Table 2-7. The largest critical reason found for two-vehicle crashes was inattention, followed closely by poor decisions or misjudgment. These two factors alone account for over 80 percent of two-vehicle crashes attributed to truck drivers.

**Table 2-8. Critical Reasons for Two-vehicle Crashes Involving Trucks**

<b>Critical Reason</b>	<b>Truck (%)</b>	<b>Other Vehicle (%)</b>	<b>Total (%)</b>
Vehicle (typically brake failure)	6	4	5
Environment	0	6	4
Driver nonperformance (sleep or sickness)	3	11	9
Driver recognition (inattention or external distractions)	46	34	38
Driver decisions (misjudgments)	36	20	25
Driver performance (poor control)	5	9	8
Driver unknown errors	3	13	10
Other/unknown	1	3	2
Total	100	100	100

Inattention or distraction was also found frequently as a related factor in the crash. Internal distractions were found to be related to almost 17 percent of the two-vehicle crashes, and external distractions were found to be related to almost 8 percent of the two-vehicle crashes. Poor surveillance, driving too fast, and making false assumptions were each found to be related to about 10 percent of the crashes, but following too close was only a factor in 4 percent of the crashes. By far, the largest related factor was prescription or over-the-counter medications which were a factor in almost 34 percent of the two-vehicle crashes.

The results described in the tables above for the critical reasons of two-vehicle truck crashes hold fairly true when looking at all truck crashes. For all truck crashes, 53 percent of the time the critical reason was not associated with the truck or truck driver. Nearly 31 percent of the crashes could be attributed to truck driver inattention, distraction, misjudgments, or poor decisions. Only 4 percent of crashes could be attributed to sleep or sickness, and only 4 percent of crashes could be attributed to poor vehicle control. Finally, a full 5 percent of crashes could be attributed to vehicle failures (typically brakes), meaning that the top 5 critical reasons accounted for almost 97 percent of crashes.

#### **2.1.4 Large Truck Crash Causation Study 2006 Results**

Coinciding with the completion of this section, newer interim results for the LTCCS were released by the FMCSA (2006). The new results were based on 967 crashes including 1127

large trucks and 959 other vehicles. A total of 251 fatalities and 1408 injuries resulted from these crashes. Additionally, while the 2004 interim results focused on two-vehicle crashes, the 2006 interim results expanded the study to include both single vehicle and multiple vehicle crashes (each comprising about 26.9 percent of the crashes).

While the new results changed some of the categories and percentages, the conclusions did not change much between analyses. One notable difference is that the 2006 interim results report that for 54.6 percent of all crashes, the truck was coded with the critical reason for the crash. This is slightly higher than the 2004 results which found that the truck was coded with the critical reason for the crash only 47 percent of the time. The discrepancy is most likely due to the fact that the 2006 results included single vehicle crashes.

The top four critical events found in the 2006 analysis are listed below and, combined, account for 92.7 percent of the crashes. Compared to the 2004 interim results, the only category of critical events that was added in the 2006 results was loss of control. Again, this category most likely arose from the fact that the 2006 analysis included single vehicle crashes.

1. Over the lane line or ran-off-the-road
2. Loss of control (such as traveling too fast for conditions)
3. Other vehicle in the travel lane (likely rear-end collisions)
4. Turning at or crossing an intersection

While the distribution of critical events remained relatively unchanged between analysis results, there were notable differences in the distribution of critical reasons (see Table 2-9, which gives percentage distribution by each of the two years in question). Truck driver recognition and decision errors still account for 66.4 percent of the crashes, but truck driver nonperformance (sleep, sickness, or medical such as heart attack or seizure), truck driver performance (poor control), and vehicle failures all were found to account for a larger share of the crashes than originally found in the 2004 interim results.

**Table 2-9. Comparing Critical Reasons between Studies**

<b>Critical Reason (when coded to the truck)</b>	<b>2004 (%)</b>	<b>2006 (%)</b>
Driver nonperformance (sleep or sickness)	3	11.6
Driver recognition (inattention or external distractions)	46	28.4
Driver decisions (misjudgments)	36	38.0
Driver performance (poor control)	5	9.2
Vehicle (brake failure, tire, or cargo failure)	6	10.1
Environment	0	2.3
Total	96	100

Finally, the 2006 large truck crash causation study interim results provided a much more detailed analysis of related factors, those that were not the critical reason but were still associated with the crash (see highlights in Table 2-10, which provides percentages of associated factors).

**Table 2-10. Related Factors Described in the 2006 LTCCS Interim Results**

<b>Associated Factors</b>	<b>(%)</b>
<b>Driver Impairment</b>	
Prescription drug use	26.3
Over-the-counter drug use	17.3
Fatigue	36.0
Work-related pressure	9.2
Illness	2.8
Illegal drug use	2.3
Alcohol use	0.8
<b>Driver Behaviors</b>	
Traveling too fast for conditions	22.9
Unfamiliar with roadway	21.6
Inadequate surveillance	13.2
Illegal maneuver	9.1
Inattention	8.5
External distraction	8.0
Aggressive driving	6.6
Following too close	4.9
Making false assumptions about other drivers	4.7
<b>Vehicle</b>	
Brake failure or improper adjustment	29.4
Cargo shift	4.0
Cargo securement	3.0

Similar to the conclusions of the 2004 analysis, fatigue, prescription drug use, and over the counter drug use (such as cold medications) were still the most prominent related factors. Interestingly, two new driver related factors, traveling too fast for conditions and unfamiliarity with the roadway, were also found to be fairly prominent, while inattention and external distractions lost ground compared to the 2004 results.

### **2.1.5 Summary and Relevancy**

This section contained a review of the recent literature on the topic of delineating causal factors for large truck crashes. The concept of an onboard driver monitoring system has been born from the behavior-based safety approach which aims to identify “unsafe” behaviors, monitor those behaviors, and feedback to encourage good behavior and discourage the “unsafe” behavior.

Based on the findings of the LTCCS, three general categories of critical events leading to crashes could be considered high priority: (1) driving over the lane or off the road, (2) turning at or crossing an intersection, and (3) rear-end collisions. The most common reasons for the critical event were driver errors in recognitions (due to inattention or distraction) and errors in decisions (misjudgments). In support of this assertion, the industry experts, truck drivers, fleet managers, and safety experts, all agreed that inattention and distraction are major problems which need to be addressed.

Industry experts, truck drivers, fleet managers, and safety experts, also all agreed that aggressive or risky truck driver behaviors, such as speeding or tailgating, were of great concern. However, contrary to popular belief, most studies agree that fatigue, in the sense of falling asleep at the wheel, is a much lower priority and only a primary factor in maybe 3 percent of truck caused crashes. Vehicle failures, typically brake failures, were only responsible for 5 to 6 percent of crashes according to the LTCCS.

Four studies were reviewed on the general topic of driver monitoring systems in the trucking industry. Each of the studies surveyed drivers, managers, or industry experts to gather their input on the concept of driver monitoring, all of the studies came to the same basic conclusion:

although privacy and misuse of the data were of primary concern, there was general acceptance within the industry for the concept of driver monitoring.

Not surprisingly, acceptance was also a function of perceived benefit. The more benefit the drivers saw in the individual system, the more positive they were towards accepting the overall concept of onboard monitoring.

In regard to the delineation of causal factors in large truck crashes, three types of studies were presented, those that interviewed industry experts, those reviewed crash statistics, and the Large Truck Crash Causation Study (LTCCS). Although, all of these sources had both advantages and disadvantages, the results of the LTCCS can probably be thought of as carrying the most weight, while the other studies can be thought of as providing confirming evidence.

These results provide a sound basis and background for the first step of the behavior-based safety approach, identifying the “unsafe” behaviors, on which is overlaid principles in driver monitoring feedback.

## **References (Section 2.0)**

Blower, D. and Campbell, K.L. (2002). The Large Truck Crash Causation Study (UMTRI-2002-31). Ann Arbor, MI: The University of Michigan Transportation Research Institute.

Council, F.M., Harkey, D.L., Nabors, D.T., Khattak, A.J., and Mohamedshah, Y.M. (2003). Examination Of Fault, Unsafe Driving Acts, And Total Harm In Car-Truck Collisions. Transportation Research Record. 1830, 63-71. (See also Council, Harkey, Nabors, Khattak, and Mohamedshah, 2004).

Council, F.M., Harkey, D.L., Nabors, D.T., Khattak, A.J., and Mohamedshah, Y.M. (2004). An Examination of Fault, Unsafe Driving Acts, and Total Harm in Car-Truck Collisions (Publication No. FHWA-HRT-04-085). McLean, VA: Turner-Fairbank Highway Research Center.



- Craft, R. and Blower, D. (2004). An Overview of the Large Truck Crash Causation Study. A Presentation Given at The 3<sup>rd</sup> Annual Stakeholder's Forum on November 30<sup>th</sup> in Phoenix, Arizona. Washington, D.C.: The Federal Motor Carrier Safety Administration's Office of Research and Technology.
- Federal Motor Carrier Safety Administration. (2006). Report to Congress on the Large Truck Crash Causation Study. Washington, D.C.: The Federal Motor Carrier Safety Administration's Office of Research and Technology. [Available Online at <http://www.fmcsa.dot.gov/facts-research/research-technology/report/lccs-2006.htm>]
- Häkkinen, H. and Summala, H. (2001). Fatal traffic accidents among trailer truck drivers and accident causes as viewed by other truck drivers. *Accident Analysis and Prevention*. 33, 187-196.
- Hanowski, R.J., Wierwille, W.W., Gellatly, A.W., Knipling, R.R., and Carroll, R. (1998). Safety Issues In Local/Short Haul Trucking: The Drivers' Perspective. *Proceedings Of The Human Factors And Ergonomics Society 42nd Annual Meeting*. 1185-1189.
- Knipling, R., Hickman, J., and Bergoffen, G. (2003). Commercial Truck and Bus Safety Synthesis Program: Synthesis 1 - Effective Commercial Truck and Bus Safety Management Techniques. Washington D.C.: Transportation Research Board.
- Matteson, A., Blower, D., and Woodrooffe, J. (2004). Trucks Involved in Fatal Accidents Factbook 2002. Ann Arbor, MI: The University of Michigan Transportation Research Institute. (See also Shrank, Matteson, Pettis, and Blower 2004.)
- Roetting, M., Huang, Y., McDevitt, J.R., and Melton, D. (2003). When Technology tells you how you drive—truck drivers' attitudes towards feedback from technology. *Transportation Research Part F* 6. pp. 275-287.

Shrank, M., Matteson, A., Pettis, L., and Blower, D. (2004). Trucks Involved in Fatal Accidents Codebook 2002. Ann Arbor, MI: The University of Michigan Transportation Research Institute.

Sullman, M.J.M., Meadows, M.L., and Pajo, K.B. (2002). Aberrant Driving Behaviours Amongst New Zealand Truck Drivers. Transportation Research Part F. 5, 217-232.

## **2.2 Driver Behavior Task Analysis**

In Section 2.1, preliminary results of the Large Truck Crash Causation Study (LTCCS) were reviewed. Based on these findings (Craft and Blower, 2004), three general categories of critical events (summarized earlier in Table 2-7) could be considered high priority: (1) driving over the lane or off the road, (2) turning at or crossing an intersection, and (3) rear-end collisions where the truck crashes into the vehicle in front. The most common reasons for the critical event (summarized earlier in Table 2-8) were driver errors in recognitions (due to inattention or distraction) and errors in decisions (misjudgments).

Building upon these results, the driving behavior task analysis presented in this report section focuses on transforming the critical incidents and critical reasons found in the LTCCS into failures in driving behavior or driver tasks. Using a reverse Failure Modes and Effects Analysis (FMEA), possible driving behaviors or tasks (the potential failures) which could lead to the crashes described in the crash causation literature (the effects) were brainstormed and discussed as the foundation for set of driver behavior monitoring tasks.

### **2.2.1 Method**

In system engineering terms, the crash causation literature detailed above is akin to a Root Cause Analysis (RCA). It provides background on how frequently truck crashes happen and why. The challenge at hand is to organize, prioritize, and translate the crash causation research into a ConOps for an onboard driver monitoring system. Although there are an infinite number of

ways this problem could be viewed, the primary goal of onboard driver monitoring is risk management, and one tool used widely in the system engineering approach for risk management is FMEA. This tool is simply a formal process to proactively identify and correct potential product failures by examining each component, how that component might fail, and what effect that failure might have on the overall system.

In this analysis we consider each specific driver behavior or task as a system component with the potential for failure. In this case, the driving behavior or task is the unknown. The most likely failure modes to crashes are rooted in two the critical reasons detailed in the LTCCS, specifically failures in recognition (to include distractions), and poor decisions. The effects and frequency of failures comes from the crash types or critical events also detailed in the LTCCS. Working backwards through the FMEA method, driving behaviors and tasks which could potentially lead to crashes can be identified. These behaviors and tasks can then be suggested as prime candidates for onboard monitoring.

### **2.2.2 Failures Resulting in Driving Over the Lane or Off the Road**

The LTCCS suggested that nearly 35 percent of truck crashes resulted from driving out of the lane or off the road. Additionally, 3 percent of truck crashes resulted from losing control of the vehicle. Although it was the largest single category of critical events found in the LTCCS, the category itself combines several crash types. Crashes which result from a lane departure could include single vehicle run-off-the-road, head-on, or lane change and merging crashes. Table 2-11 breaks down each crash type and primary mode of failure into possible behavioral failures on the part of the truck driver by showing the effect or crash scenario by mode or critical reason and by failure and possible behaviors.

**Table 2-11. Possible Behavioral Failures for Crashes Resulting from Lane Departure**

<b>Effect (Crash Scenario)</b>		<b>Mode (Critical Reason)</b>	<b>Failure (Possible Behavior Failures)</b>
1	Single vehicle runs off the road or two vehicle head-on collision	Recognition	<ul style="list-style-type: none"> <li>• Driver takes eyes off the road (distraction)</li> <li>• Fatigue/falling asleep</li> </ul>
		Decision	<ul style="list-style-type: none"> <li>• Driving too fast for weather</li> <li>• Overdriving headlights at night</li> <li>• Curve over speed</li> </ul>
2	Overtaking	Recognition	-
		Decision	<ul style="list-style-type: none"> <li>• Misjudging the speed of an oncoming vehicle</li> <li>• Misjudging the amount of safe passing roadway available and the time it will take to complete the maneuver</li> </ul>
3	Lane change/merge	Recognition	<ul style="list-style-type: none"> <li>• Failure to check mirrors</li> <li>• Failure to properly adjust mirrors</li> </ul>
		Decision	<ul style="list-style-type: none"> <li>• Failure to use turn signals</li> </ul>

Of the potential behavioral failures, speed is fairly easy to measure. However, absolute speed alone is not the issue. The issue is speed relative to roadway conditions, which could be roadway design such as in the case of curve over speed or a combination of roadway design and weather conditions. Other driver decisions, such as misjudgments of oncoming vehicle speed and distance, are far more difficult to monitor as they would involve the need to know or measure the speeds and distances of the surrounding vehicles.

Distraction and fatigue (or falling asleep) are also somewhat difficult to measure, but there are options and COTS devices available. The most direct measure for both distraction and sleep is monitoring eye scan behavior; however, there may also be the possibility of using surrogate measures such as lane keeping performance.

### **2.2.3 Failures Resulting from Turning at or Crossing an Intersection**

Another large category of critical events suggested by the LTCCS was crashes resulting from turning at or crossing an intersection, approximately 27 percent of the crashes caused by the truck or truck driver. Again, although this category comprises a large amount of crashes, there

are numerous permutations of intersection crashes, including making a left turn across the path of an oncoming vehicle, straight crossing path, left turn across the path of lateral traffic, and right turn into the path of lateral traffic. Furthermore, intersection crashes can be complicated by control method, uncontrolled, stop sign, or traffic signal. Table 2-12 details the possible driving behavior failures which may result in an intersection crash by, like Table 2-11, breaking down each crash type and primary mode of failure into possible behavioral failures on the part of the truck driver by showing the effect or crash scenario by mode or critical reason and by failure and possible behaviors.

**Table 2-12. Possible Behavioral Failures for Intersection Crashes**

<b>Effect (Crash Scenario)</b>	<b>Mode (Critical Reason)</b>	<b>Failure (Possible Behavior Failures)</b>
Intersection crashes	Recognition	<ul style="list-style-type: none"> <li>• Driver takes eyes off the road</li> <li>• Driver does not see intersection control (stop sign or stoplight)</li> <li>• Driver does not check lateral traffic in both directions before crossing</li> <li>• Driver does not check or see oncoming traffic before turning</li> </ul>
	Decisions	<ul style="list-style-type: none"> <li>• Driver misjudges oncoming vehicle speed or distance</li> <li>• Driver misjudges lateral vehicle speed or distance</li> <li>• Driver does not stop for intersection control (stop sign or stop light)</li> <li>• Driver does not properly yield to a vehicle with the right-of-way</li> </ul>

Intersection crashes often result from an extremely complicated set of causal factors. The main difficulty in monitoring intersection behavior is that many of the crashes result from misjudgments or poor decisions. In order to detect and monitor these decisions, one would need to know the speeds and positions of all the vehicles approaching the intersection. Although this may be possible one day with the advent of intelligent intersections, vehicle-to-infrastructure, and vehicle-to-vehicle communications, these technologies are still a ways off. However, what may be possible in the present or near future is monitoring whether the driver intentionally or unintentionally disobeys traffic controls, such as stop signs or stop lights.

### 2.2.4 Failures Resulting in Rear-End Collisions

The third major category of critical events suggested by the LTCCS was same-lane crashes or rear-end collisions which accounted for approximately 28 percent of the crashes caused by the truck or truck driver. Table 2-13 details the possible driving behavior failures that may result in a rear-end collision, where the truck strikes the vehicle in front. Unlike intersection crashes, many of these behaviors are prime candidates for monitoring both directly and indirectly with current sensor technology.

**Table 2-13. Possible Behavioral Failures in Rear-end Crashes**

<b>Effect (Crash Scenario)</b>	<b>Mode (Critical Reason)</b>	<b>Failure (Possible Behavior Failures)</b>
Rear-end collision	Recognition	<ul style="list-style-type: none"> <li>• Driver takes eyes off the road (distraction)</li> <li>• Fatigue/falling asleep</li> <li>• Failure to anticipate changes ahead in traffic (stopped traffic or turning vehicles)</li> <li>• Failure to predict and react to vehicle cut-ins</li> </ul>
	Decision	<ul style="list-style-type: none"> <li>• Following too close</li> <li>• Following too close for weather</li> <li>• Speeding compared to traffic flow (aggressive driving)</li> </ul>

### 2.2.5 Other Behavior or Task Failures and Contributing Factors

The issues of fatigue and drowsy driving (falling asleep while driving) are interesting. While they appear often as potential behavioral failures in the reverse FMEA analysis, the LTCCS found that only about 3 percent of crashes were primarily caused by drivers actually falling asleep at the wheel. Additionally, fatigue was only listed as a related factor 5 percent of the time. It should be noted that there is a distinction to be made when talking about fatigue and talking about drowsy driving or falling sleep at the wheel. Fatigue is a condition that occurs long before drowsy driving or actually. Fatigue can mimic distraction which was also mentioned as a

possible cause of many crash types, and the symptoms common to both include reduced scanning patterns and scanning frequency, slowed reactions, and making poorer decisions.

While monitoring whether or not the driver is actually falling asleep at the wheel is probably not the highest priority based on the crash causation studies, it has been reported as a major safety issue in the trucking industry, especially for long-haul drivers. An ideal onboard driver monitoring system may provide drowsy driver monitoring as an option to be used with long-haul drivers. Additionally, one driver monitoring countermeasure already mandated by state and federal regulatory agencies is the logging of driver hours of service. Since this logging is already required of drivers, any onboard monitoring system should automatically handle this task since any perceived system benefits, such as cutting down on paperwork, will help with overall system acceptance.

Vehicle failures, typically brake failures, were responsible for 5 to 6 percent of crashes according to the LTCCS. Consideration might be given to monitoring driver behaviors that can lead to or cause vehicle failures, such as riding the brakes when descending prolonged steep hills. Finally, although not specifically the cause of crashes, safety belt usage is essential to death and injury reduction in a crash, and drivers not using seat belts has been reported as a concern of the trucking industry. For light duty passenger vehicles (but not commercial vehicles), real-time feedback of safety belt usage to the driver already exists. However, a well-designed safety belt sensor (e.g., one that cannot be spoofed if the driver latches the belt and sits on it) coupled with real time and delayed feedback would be a useful onboard monitoring system to enhance commercial vehicle safety.

## **References (Section 2.2)**

Craft, R. and Blower, D. (2004). An Overview of the Large Truck Crash Causation Study. A Presentation Given at The 3<sup>rd</sup> Annual Stakeholder's Forum on November 30<sup>th</sup> in Phoenix, Arizona. Washington, D.C.: The Federal Motor Carrier Safety Administration's Office of Research and Technology.

## **2.3 Principles to Guide Driver Monitoring Feedback**

### **2.3.1 Overview**

The end goal of onboard driver monitoring is to be able to provide the driver with feedback that will have a positive influence by promoting safe behaviors and discouraging unsafe behaviors. As part of the Roetting, Huang, and McDevitt (2003) study, truck drivers were surveyed on questions of how they would like to receive feedback from an onboard driver monitoring system. Unsurprisingly, they found little consensus over how feedback on driving performance should be given. Their results showed that when asked the generic question of how to provide feedback, 47 percent opted for via a dashboard device, 37 percent opted for post-driving feedback, and 30 percent opted for some sort of voice-auditory system. When post-driving feedback was suggested as an option, drivers generally selected a time summary interval between once a week and once a month, as opposed to longer or shorter time intervals. One thing with which the drivers did agree was that any technology providing feedback should not interfere with the driving task and should not be a distraction. Clearly, there is a delicate balance between life-saving real-time feedback and distracting feedback

### **2.3.2 Constituent Tasks of Driving**

Over the years starting as early as Gibson and Crooks (1938), there have been a number of approaches used to try to break down the skill of driving into its various component tasks. While this task breakdown may vary from study to study in both nature and complexity, the one thing most everyone agrees upon is the fact that driving is mostly a visual task guided by perception. Drivers must perceive the road, the vehicles around them, any threats to their intended path, and so forth. Drivers must also make decisions like “Should I pass?” or “Is there enough gap to turn in front of this vehicle?” And finally, drivers must use the vehicle controls, throttle, steering, brakes, and gears to control the vehicle maintaining its desired path. Errors can occur in all stages of processing which could lead to “unsafe” conditions or even crashes.

For the drivers of large trucks, all of these tasks still apply. The major differences between truck drivers and car drivers lie in the maneuvering characteristics of the vehicle. Since trucks are far



less maneuverable, they are less forgiving and tolerant of errors in perception, decision making, or vehicle control, requiring drivers to be even more attentive and vigilant. Other differences include generally longer driving hours, and additional reporting requirements (such as documenting and reporting hours of service).

Unfortunately, the component tasks of driving are too often situation dependent to provide any overall guidance on the issue of driver feedback.

### **2.3.3 What is the Role of Driver Monitoring Feedback?**

Given that driving is composed of many widely varying tasks, the answer to the question of how to provide driver feedback likely varies depending on what specific feedback being provided. In order to start deciding what feedback should be given in what way, we must first establish how the role of onboard driver monitoring feedback fits into the overall scheme of driver assistance. Figure 2-1 was first published in a report by NHTSA (1992) as a means of describing the relationship between urgency (x-axis) the intensity of intervention required (y-axis). Since the first appearance of this graph, two categories have been added by researchers at California PATH: situational awareness and onboard monitoring feedback.

Figure 2-1 shows the continuum of warning as functions of time running out vs. intensity of action – normal driving, onboard monitoring feedback, situational awareness, driving warning systems, partially automatic control, fully automatic control, through an unavoidable crash. A warning system, in the classical sense, provides the driver with information that a specific, urgent threat exists, and immediate action must be taken to avoid that threat, and onboard monitoring alone is such a system only with a real-time feedback and warning function also provided. The most prominent examples in the automotive realm are forward and side collision warning system. Designing a warning system that will be accepted by drivers typically considers issues such as reaction time and false alarms.

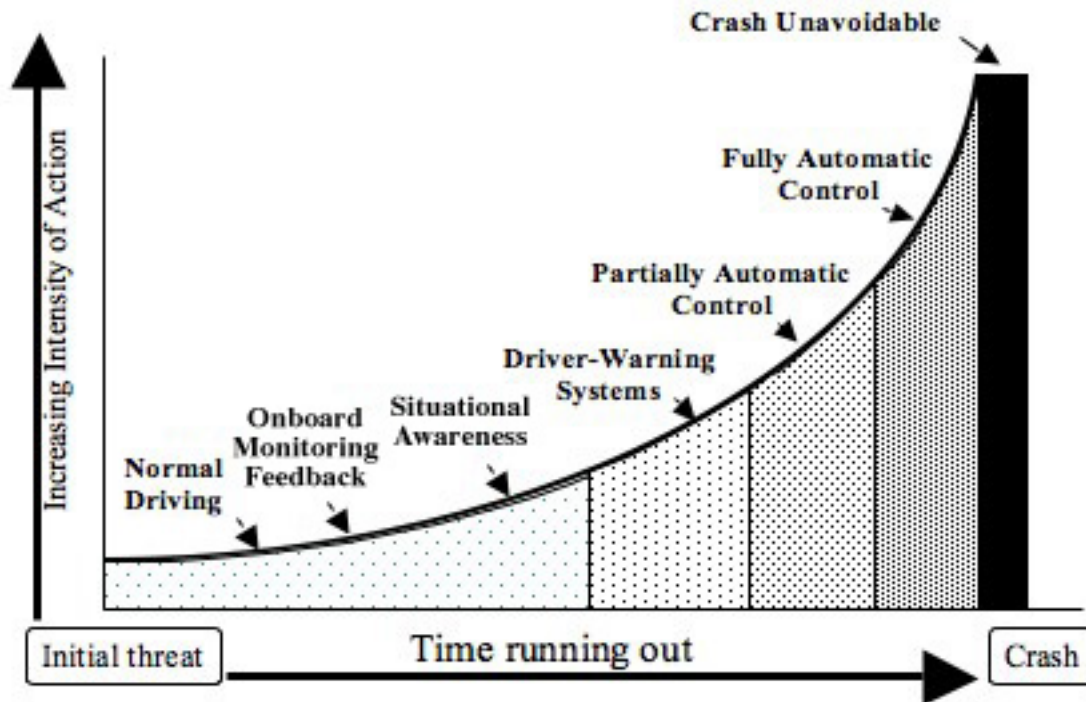

**Figure 2-1. Onboard Monitoring Feedback in the Scheme of Driver Assistance Systems.**  
 (Figure Adapted from NHTSA 1992)

Situational awareness systems are generally one step removed in urgency with the intention of providing the driver with supplemental information, upon which better informed decisions can be made. The best example of a situational awareness system is a side object detection system. When an object in the driver’s blind spot is detected, the information is transferred or fed back to the driver. The difference between situational awareness and warning is that an immediate threat does not need to be present. In designing a situational awareness system, timing issues are generally considered, but timing and false alarms are much less critical.

Elements of OBMS would fit at various points in this continuum, with elements of such a system providing onboard monitoring feedback and situational awareness, depending on the time urgency of the threat posed to the driver. Behavior monitoring feedback attempts to convey that the driver is currently engaging in what might be considered an unsafe behavior. A prime example of this is feedback provided by most vehicles on driver seat belt usage. This feedback is not a collision-imminent warning, as there is no immediate threat, but it does indicate that the behavior of not wearing your seatbelt is dangerous. In the design of behavioral feedback, the

issue of timing in relationship to crash is not critical. False alarms are also less critical, unless the feedback is overly distracting.

### **2.3.5 When Should Feedback be Given: Immediate or Delayed?**

Perhaps the first and largest question regarding onboard driver monitoring feedback is the question of whether the feedback should be immediate (real-time and somehow provided in the vehicle) or can be delayed (allowing post-processing). The general guiding principle on this issue comes down to whether or not the unsafe behavior is persistent and correctable. Nonuse of the seatbelt is persistent and correctable by the driver, and thus, immediate feedback is a good option. Following too close is also a good candidate for immediate feedback, as it is a persistent state correctable by the driver.

Other monitoring parameters do not lend themselves well to immediate feedback. As an example, if the driver just performed a hard braking because he was distracted and did not see the car in front of him start braking, the condition was not persistent or correctable. The event is over and providing the driver with immediate feedback that he just performed a hard braking event is pointless. In this particular example, feedback would better serve the driver by summarizing how many hard braking events he found himself in during the past week or month. In a case where a single event does not necessarily indicate a problem but frequent events may be indicative of a larger correctable problem, then delayed feedback would be more appropriate (as would be providing real time feedback if, for example, the frequency of these events within a short time period, is excessive).

### **2.3.6 Should Feedback be Framed as Positive or Negative?**

Another issue which needs to be considered is whether the feedback provided should be positive or negative. In the case of immediate or in-vehicle feedback, positive feedback would generally be avoided. As a general vehicle design principle, one does not add in-vehicle displays unless necessary for fear of introducing distraction. Thus, for the case of following too close, the preferred feedback method would only provide a warning when the driver was following too close for an extended period of time. However, when giving delayed feedback, several of the

studies mentioned earlier reported that drivers wanted to hear the positive about their driving and not just the negative.

### **2.3.7 Feedback Modality**

The final topic of onboard driver monitoring feedback is how to provide immediate in-vehicle feedback, specifically, through which modality: auditory, visual or both. As discussed earlier, driving is an extremely visual task. The driver is constantly scanning the road, the instruments, and the traffic around the vehicle. Thus, the use of visual displays, such as for driver monitoring feedback does not guarantee that the driver will see or notice the information immediately, and any time spent looking at the information will take from time that might be better spent scanning the roadway for hazards. Still, most in-vehicle warning or situational awareness systems use some visual component. If the information is non-critical, then using a visual display alone can be completely acceptable as the driver can easily ignore the warning when their attention is occupied elsewhere and attend to the warning once their workload has subsided. It is also well known in the automotive industry that drivers tend to prefer static warning, as dynamic or flashing warnings tend to be less easily ignored and more often considered annoying.

Typically, auditory feedback is used in situations where an immediate response is needed, and the driver's attention may or may not be focused on the feedback device (or the road for that matter). The problem with auditory feedback is that it quickly becomes annoying and even distracting when overused or used in the wrong situation because drivers have no means to avoid it. Thus, it would not be recommended to follow the advice of the 30 percent of drivers who responded that they would prefer feedback through some auditory-voice type system in Roetting, Huang, and McDevitt (2003).

Finally, there are cases and times where auditory warnings and flashing visual warnings have been used for non-critical situations, e.g., the seat belt monitoring system. In the case of the seat belt monitoring system, the annoyance and distraction factor of the auditory warning and the flashing visual warning was intentional with the hope that it would persuade drivers to comply at

the start of their trip. Of course, the disadvantage of this strategy is that too much distraction and annoyance can cause the driver to attempt to disable the system entirely.

### **References (Section 2.3)**

Gibson, J. and Crooks, L. (1938). A Theoretical Field-Analysis of Automobile Driving. *The American Journal of Psychology*, 51(3), 453-471.

National Highway Traffic Safety Administration. (1992). NHTSA IVHS Plan (Report No. DOT-HS-807-850). Washington DC: NHTSA Office of Crash Avoidance Research.

Roetting, M., Huang, Y., McDevitt, J.R., and Melton, D. (2003). When Technology tells you how you drive—truck drivers' attitudes towards feedback from technology. *Transportation Research Part F*, 6, 275-287.

## **2.4 Onboard Monitoring Review**

### **2.4.1 Driver Monitoring in the Context of the Behavior-Based Safety Approach**

The concept of operator (driver) monitoring is neither new, nor limited specifically to the trucking industry. Sherry (2001) identified and compared operator monitoring systems used in the maritime, air freight, motor carrier, and rail industries. A more recent paper (Lotan and Toledo, 2005) discussed a pilot program in Israel which would provide driver monitoring and feedback for teen drivers.

The general case for truck driver monitoring in the trucking industry has already been made through research sponsored by the Federal Motor Carrier Safety Administration (FMCSA) and is best summarized in a technical brief (Behavioral Science and Technology, Inc., 2000). In its most simplistic form, the behavior-based safety approach is a method for improving safety, by which behaviors critical to safety are identified and monitored vis-à-vis mutual goals, rewards, expectations and punishments.. Safe behavior is rewarded and unsafe behavior is discouraged and improved upon, thereby proactively improving overall safety.

### **2.4.2 Driver Monitoring Research Review**

There is much literature devoted to the many issues surrounding truck and truck driving safety, all of which can be both relevant and tangential to the concept of onboard driver monitoring, and much of that literature is discussed throughout the various sections of this report. However, there have only been about four major published studies which have specifically focused on the acceptance of onboard driver monitoring systems in the trucking industry. In the first study, Sherry (2001) interviewed both management and operators in the maritime, air freight, motor carrier, and rail industries. At the time, many of the onboard monitoring COTS devices reviewed later in this report were in existence and in use by the companies he interviewed. However, management acceptance of onboard monitoring was mostly concentrated around the issues of reducing engine idle time and fuel consumption or accident/event recording. Most management incentives based on the monitoring and feedback devices were given for reducing engine idle time.

From the driver interviews conducted in this first study, it was reported that 42 percent of the drivers would have no problems with a driver monitoring system, but almost 58 percent felt that the in-vehicle monitoring systems had been used to unfairly discipline drivers. Drivers were more accepting of systems that included some sort of collision avoidance system or provided additional tangible benefits, such as reducing paperwork and logging requirements. It was also reported that drivers perceived as “good” drivers were more positive and accepting towards the monitoring systems than were drivers that were considered more problematic. Summarizing from interviews across industries, Sherry (2001) concluded that several factors (outlined in Table 2-14 in two columns, Positive Influences on Acceptance and Negative Influences on Acceptance) were frequently cited in support of or against operator monitoring systems.

**Table 2-14. Factors Influencing Onboard Monitoring Acceptance**

Positive Influences on Acceptance	Negative Influences on Acceptance
<b>Improved safety (if the technology lives up to its promise).</b>	<b>Fear of embarrassment or self-consciousness at being monitored all the time.</b>
<b>Liability protection (such as when the driver is not at fault for a crash).</b>	<b>Fear of liability or unfair accountability on the part of drivers such as being determined as responsible for a crash.</b>
<b>Efficiency (such as reducing paperwork).</b>	<b>Concern that the monitoring parameters are not indicators of safety.</b>
<b>Monetary incentives.</b>	<b>Misuse of the collected data.</b>

In the second reviewed study, Knipling, Hickman, and Bergoffen (2003) found support for driver monitoring among nearly 33 percent of trucking industry safety managers. In their survey, 36 percent of the respondents reported using some form of driver monitoring system with management review and feedback, and 33 percent of the respondents ranked driver monitoring and feedback as one of their “Top Five” choices for solutions to help improve safety. Interestingly, when given the option of driver monitoring without management review (thus ensuring driver privacy), only 9 percent of the safety managers ranked this option in their “Top Five” and the option fell overall to last place (out of 28 solutions). Most industry experts and carrier safety managers seemed to agree that driver monitoring without management review would be ineffective.

The final two studies, Roetting, Huang, and McDevitt (2003 and 2005), extensively examined the topic of truck driver monitoring and feedback from the driver’s perspective. In the 2003 study, a total of 66 long and short haul drivers, supervisors/managers, and insurance industry safety professionals participated in 9 focus groups. These focus groups reported similar opinions as those described above. Drivers generally felt that monitoring could have potential safety benefits and possibly vindicate the driver in the even of an incident or crash. However, privacy concerns and mistrust over the use of data were also voiced. Drivers were also concerned that

feedback would be primarily negative and lead to programs focused on punishments, as opposed to incentives which reward good driving behavior.

The 2005 study surveyed 239 long and short haul drivers throughout 40 states and Canada. Drivers were generally positive towards the concept of feedback with less than half of the drivers surveyed (42 percent) responding that they were currently getting adequate feedback on their driving. Similar to the earlier focus groups, more than half the of the drivers (59 percent) felt that positive feedback would be more useful than negative feedback, and 56 percent felt that the greatest potential benefit of in-vehicle monitoring was defending the driver in the event of a crash. Unsurprisingly, the greatest concern found in the survey was over the issue of privacy. Over two-thirds or 65 percent of the survey respondents were concerned with the possibility that the data collected by the onboard monitoring system might be misused.

All of the studies outlined above basically came to the same conclusions. Truck drivers were not universally opposed to the concept of onboard monitoring and feedback, and the issues surrounding privacy and misuse of the data being collected were of primary concern. The studies all also tended to reveal that acceptance was a function of perceived benefit. The more benefit the drivers saw in the individual system, the more positive they were towards accepting the overall concept of onboard monitoring.

### **2.4.3 Onboard Monitoring COTS Review**

#### Overview

A search for COTS onboard truck driver monitoring systems turned up six major manufacturers: XATA, Delphi, Accident Prevention Plus, Cadec, QualCOMM, and DriveCam. These companies have been releasing on-board monitoring (OBM) products since as early as 2000. Two relative newcomers to the field of driver monitoring are AllTrackUSA and DriveDiagnostics. AllTrackUSA makes a variety of product marketed towards teen drivers and fleet management, and DriveDiagnostics is an Israeli start-up with plans to make both a teen driver monitor and a fleet version.



The features promoted in most OBM products include real-time location tracking, delivery status, fuel performance, and driver logs. In general, these systems emphasize savings on fleet operations and maintenance costs. An overview of a typical onboard driver monitoring system is shown in Figure 2-2. That figure shows that the OBM system generally consists of three major components: sensors, a processing unit, and feedback devices. The most commonly-used sensors include the speedometer, tachometer, odometer, throttle angle encoder, GPS receiver, accelerometer, and steering encoder.

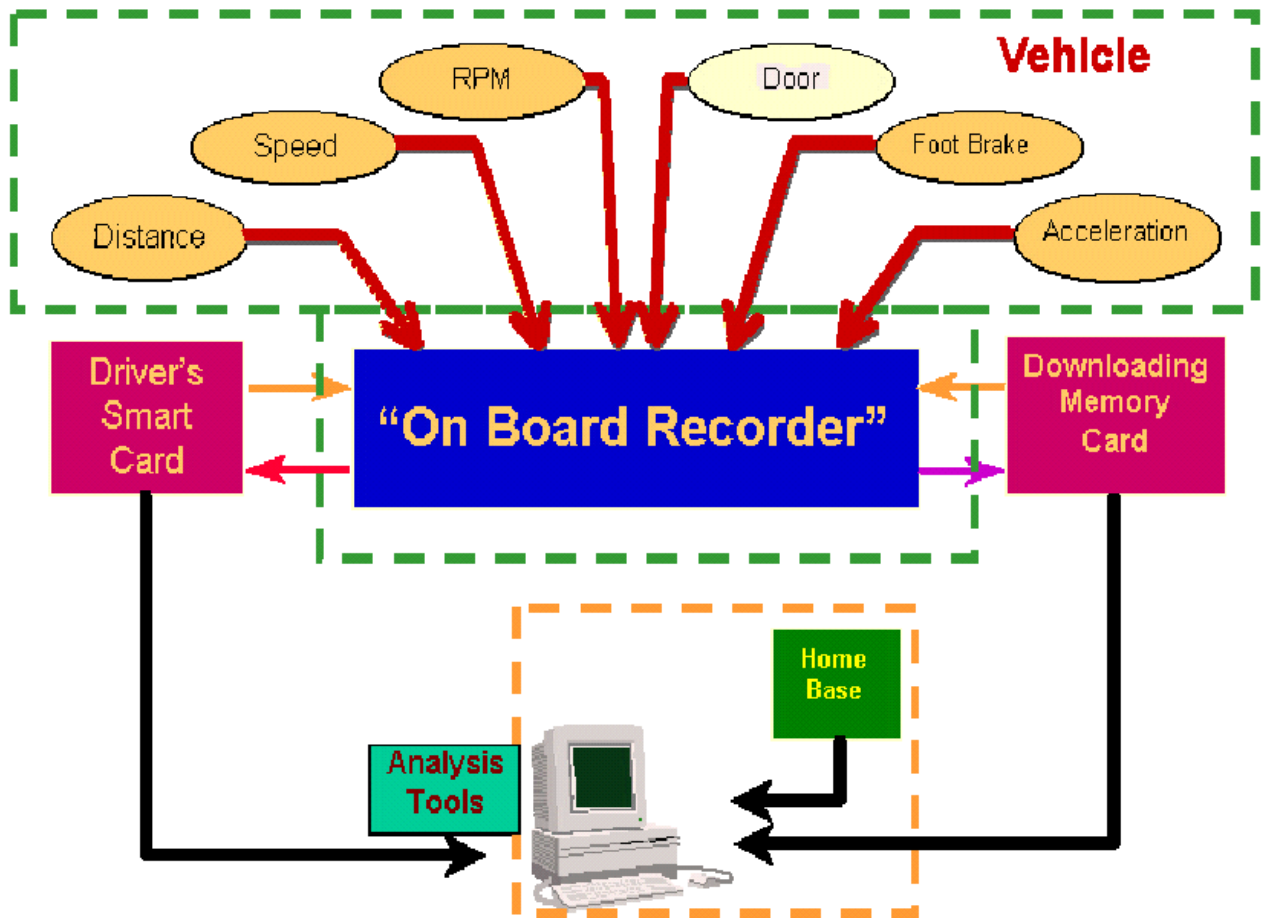

Figure 2-2. A Typical OBM System<sup>1</sup>

By employing these sensors, the COTS systems measure the driver performance by monitoring signal use, position, speed, acceleration, and vehicle mechanical states, e.g. engine rpm, throttle

<sup>1</sup> This figure and the information on the Accident Prevention Plus AP+ series products were from the NHTSA website at the following URL: [http://www-nrd.nhtsa.dot.gov/edr-site/uploads/accident\\_prevention\\_plus.pdf](http://www-nrd.nhtsa.dot.gov/edr-site/uploads/accident_prevention_plus.pdf)

angle, brake pressure, and so on. All these systems can be installed in a vehicle easily. Most of them also provide advanced driver identification system to avoid unauthorized use of the vehicle, but, there are some basic feature differences between systems as illustrated in Table 2-15. (Systems are: XATA, Delphi, APPlus, Cadec, QualComm, DriveCam, AlltrackUSA and DriveDiagnostics. Features are: preventative maintenance monitoring, event recording using camcorder, remote deceleration and shutdown, real-time asset tracking, GPS-based ‘geofencing’, driver identification, trailer door security and wireless communication.)

Feedback can be provided to the driver either in real-time or after the data has been downloaded and analyzed. Real-time feedback is typically provided to the drivers through displays or speakers. Table 2-16 compares the feedback methods employed across systems. (The systems are the same as with Table 2-15, but the methods are: text messaging, audible or visible warnings and off-line feedback.)

**Table 2-15. Basic Feature Comparison among OBMS Products**

Company	Features							
	Preventative maintenance monitoring	Event recording using camcorder	Remote deceleration and shutdown	Real-time asset tracking	GPS-based “geo-fencing”	Driver identification	Trailer door security	Wireless
XATA	×			×		×		
Delphi	×		×	×	×	×	×	
APPlus						×		
Cadec					×		×	×
QualCOMM				×				×
DriveCAM		×				×		
AllTrackUSA <sup>2</sup>				×	×			×
DriveDiagnostics	×			×		×		×

<sup>2</sup> AllTrackUSA makes a variety of products. Not all products include all of the features noted here.

**Table 2-16. Comparison of Approaches Taken to Provide Feedback to Drivers**

Company	Feedback Device		
	Text Messaging System	Audible and/or Visual Warnings	Offline Processing
<b>XATA</b>	×		×
<b>Delphi</b>	×		×
<b>APPlus</b>			×
<b>Cadec</b>	×	×	
<b>QualCOMM</b>	×		×
<b>DriveCAM</b>			×
<b>AllTrackUSA<sup>2</sup></b>		×	×
<b>DriveDiagnostics</b>			×

XATA

XATA (<http://www.xata.com/>) is a company that has been around since 1985 and got their start in the electronic driver log business. Their current OBM product is called XATANET, and it is advertised primarily as a fleet management and fleet intelligence system with benefits such as real-time tracking, optimizing fleet utilization, and addressing safety and security concerns. The functions provided by this system as described on the XATA website include the following:

1. Increased Driver Productivity
  - Delivery status, routes, schedules
  - Analysis of speed, idling, braking, RPM, MPG and more
  - Two-way driver messaging
2. Increased Fuel Economy (through analysis of idle time and driving habits)
3. Compliance with electronic DOT logs and reporting requirements
4. Improved Safety and Security
  - Real-time asset tracking
  - Monitoring speed and rapid stops
  - Accident reconstruction

## 5. Improved Fleet Maintenance (monitoring engine diagnostics)

The XATA systems incorporates GPS, speedometer, tachometer, odometer, fuel rate sensor, throttle position, braking (on/off only), clutch (on/off only). The two-way messaging system allows the vehicle to send remote telemetry back to the fleet managers and the fleet managers to communicate with the drivers.

### Delphi's TruckSecure

Delphi's TruckSecure system is a service offered in partnership with MobileAria (<http://www.mobilearia.com/prodserv/trucksecure.shtml>). The system is a fleet management tool that is advertised as a means to reduce the possibility of cargo trucks being used to threaten homeland security. The functions provided by this system include:

1. Driver authentication (ID and PIN) to prevent unauthorized use
2. Increased security with wireless key fob and panic button
3. GPS-based real-time asset tracking and "geo-fencing"
4. System tied to a call center that monitors vehicle telemetry and notifies fleet managers of alerts
5. Remote vehicle disablement capable of gradually decelerating the vehicle to a stop and disabling the engine

The installed sensors include GPS, speedometer and odometer monitors, and cellular and satellite communications. This system includes a small display where the driver can receive text messages.

### Accident Prevention Plus

The main goal of APP system was to provide security for unauthorized use of vehicle and to monitor vehicle operational data for accident prevention. Unfortunately, at the time of this report, no current information could be found on this company or their product, and it is likely that the company and/or product has been discontinued. According to archived documents, the

system was advertised as an aid in driver training, driver evaluation, and maintenance purposes. More specifically, the system was supposed to:

1. Prevent unauthorized use of a vehicle
2. Monitor vehicle operational data
3. Record 50 seconds of data before and 10 seconds of data after an accident

The operational data that was supposed to be collected included driving chronologies, idling chronologies, 20 most recent speed violations, maximum speed, maximum acceleration/deceleration, speed histograms, engine speed histograms, brake intensity histograms, brake occurrence, speed ranges, and gear position histograms. The system also was supposed to record distance driven, maximum speed, and the number of driving periods above a selected duration. The employed sensor suite include speedometer, accelerometer, tachometer, fuel rate sensor, gear position sensor, braking (on/off), lights (on/off). The system was not supposed to include any interface to interact with the driver. It was supposed to functions mostly as a “black box” recording data for off-line analysis.

### Cadec

Cadec Corporation (<http://www.cadec.com/>) has been around since 1976 and got their start in electronic DOT logging capabilities. The company currently offers the Cadec Mobius TTS “mobile information system.” The system integrates onboard computers, handheld devices, and wireless communications to provide a paperless tracking and delivery system. However, the system also has additional features concerning safety, security, and DOT logging compliance. This system includes the following features:

1. Delivery status, route information, and schedules
  - Real-time asset and route tracking
2. Instant event notification
  - Trailer door security
  - Trailer temperature tracking
  - Border crossing notification

3. Detailed driver and vehicle information
4. Electronic logging compliance

The installed sensors include the speedometer, odometer, GPS, and tachometer. A touch screen display is used to communicate with the driver; however, text messages can only be displayed if the vehicle is not in motion. Although the advertisements suggest that detailed driver and vehicle information is collected by the system, a detailed description of just what information is collected was not found.

### QualCOMM

QualCOMM (<http://www.qualcomm.com/qwbs/solutions/prodserv/sentrac.html>) makes a series of products including the SensorTRACS and TrailerTRACS for the purpose of real-time asset tracking and fleet maintenance monitoring.

The SensorTRACS system monitors speed, RPM, and engine idle summaries and sends that data through wireless communications in near real-time back to the fleet management. This can: (1) increase fuel savings by reducing over-idle, over-revving, and excessive speed and (2) reduce engine wear and hard braking.

The TrailerTRACS system provides real-time asset location tracking system, and other add-on modules include electronic documentation of hours of service, and proactive vehicle maintenance, and panic buttons for security. The employed sensors include speedometer, odometer, throttle position sensor, and tachometer. In-vehicle text messaging and communications systems are also available as add-ons.

### DriveCam

The main purpose of the DriveCam system (<http://www.drivecam.com/>) is safety and driver training. The system integrates video technology and management software to identify high-risk driving habits. It records large g-force events such as hard braking, fast lane changes, and collisions. Their system can record 10 seconds of audio and video both before and after a large g-force event or accident. The g-force threshold is adjustable and can be adapted to different

vehicles. The employed sensors include accelerometers and cameras, which are used to record events and accidents. The DriveCam system focuses entirely on recording video of what's going on inside and outside the vehicle, as opposed to recording any engine-based performance measures. The only feedback provided by the system is real-time feedback in the form of a light which lets the driver know that an incident has occurred and triggered the cameras to save their recorded data.

### AllTrackUSA

AllTrackUSA (.com) makes a variety of products for both passive driver monitoring and for real-time fleet asset tracking through the use of GPS and cellular phone technology. The black box device monitors aggressive driving using an accelerometer and a connection to the vehicle's CAN bus to read parameters such as engine speed and accelerator position. Some of the systems are outfitted with cellular communications for real-time asset tracking and real-time event notification (excess speed or electronic geo-fencing). For security, the some of the systems also offer remote door unlock and remote starter enable/disable features.

Most of the systems operate in a black box capacity where data can be downloaded to generate off-line driver reports. One of the devices, the Audio Monitor provides driver feedback in real-time in the form of a loud beep whenever aggressive driving (high-g maneuvers) are made.

### DriveDiagnostics

DriveDiagnostics, Ltd., is an Israeli start-up that intends to make products for monitoring both teen drivers and fleet vehicles. Very little information is freely available on any of their upcoming products. Based on the web descriptions of their future products, they will likely contain, at minimum, GPS and accelerometers. Feedback will likely be given in the form of reports generated off-line after downloading the data.

### **2.4.3 COTS Summary and Conclusions**

The COTS systems built specifically for the trucking industry generally focus on fleet maintenance, asset tracking, and on saving operations costs, but many have features related to

driver monitoring and safety. Generally, as a result, these systems monitor driver behaviors from the perspective of the vehicle's mechanical conditions and motions.

The systems specifically focused on safety rely almost entirely on high-g incidents as the primary measure of driver safety. While high-g incidents might be one measure of "unsafe" driving, they most certainly aren't the only measure. It is clear that none of these individual products are comprehensive from the standpoint of monitoring safety related driver behavior.

#### **References (Section 2.4)**

Behavioral Science and Technology, Inc. (2000). The Potential Application of Behavior-Based Safety in the Trucking Industry (Publication No. FMCSA-MCRT-00-009). Washington DC: Federal Motor Carrier Safety Administration.

Knipling, R. (2005). Evidence and Dimensions of Commercial Driver Differential Crash Risk. Proceedings of the Third International Driving Symposium on Human Factors in Driving Assessment, Training, and Vehicle Design. pp. 2-8.

Lotan, T. and Toledo, T. (2005). Evaluating the Safety Implications and Benefits of an In-Vehicle Data Recorder to Young Drivers. Proceedings of the Third International Driving Symposium on Human Factors in Driving Assessment, Training, and Vehicle Design. pp. 448-455.

Roetting, M., Huang, Y., McDevitt, J.R., and Melton, D. (2003). When Technology tells you how you drive—truck drivers' attitudes towards feedback from technology. Transportation Research Part F 6. pp. 275-287.

Roetting, M., Huang, Y., McDevitt, J.R., Melton, D., Smith, G.S. (2005). Feedback by technology: Attitudes and opinions of truck drivers. Transportation Research Part F 8. pp. 277-297.



Sherry, P. (2001). In-Vehicle Monitoring Technologies: Review of Current Use and Potential Enhancement Through Behaviorally Based Safety Processes (Report Submitted to the American Trucking Association Foundation). Denver, CO: The University of Denver.

## **2.5 Proposed Driver Monitoring Tasks and Methods**

In this section, the monitored parameters and the type of feedback monitoring categories or behaviors listed below are examined:

1. Speed Selection. *Is speed too fast for the roadway, traffic or weather conditions? Is speed in excess of posted speed limit?*
2. Following Behavior. *Are car- or truck-following time gaps too close for roadway or weather conditions?*
3. Attention (or Inattention). *Are the driver's eyes on the road? (This is difficult to measure, so surrogate measures such as lane keeping performance may be the default method of detection.)*
4. Fatigue. *Is the driver tired? (Again, surrogate measures as lane keeping performance may be the default method of detection.) Are hours of service rules being maintained?*
5. General Safety. *Are seat belts being used? What is the engine RPM? Is there undo acceleration? What is the fuel consumption rate?*

These were synthesized and categorized from the results of the review and analysis of the literature described earlier. This list is shorter than other taxonomies that can be given, because it is noted that within each topic can be multiple and sometimes redundant parameters were identified as candidates for monitoring.

This list can be expanded into 'topics', of which we have identified eleven:

1. Monitoring Vehicle Speed
2. Monitoring Following Distance
3. Monitoring Attention
4. Monitoring Hard Braking Incidents
5. Monitoring Lane Position
6. Monitoring Lane Changes

7. Monitoring and Recording Incidents
8. Monitoring Fatigue
9. Monitoring Hours of Service
10. Monitoring Behaviors at Intersections
11. Monitoring Other Vehicle Parameters

Some of these candidates, such as monitoring behaviors at intersections, are likely beyond the capabilities of current technology. Others, such as monitoring curve overspeed or fatigue, may ultimately prove too costly.

Each topic is presented as a self-contained summary featuring of the following format:

- Introduction
- Candidate Driver Behaviors for Onboard Monitoring
- Driver Feedback Recommendations
- Additional Discussion
- Cross References
- Key References

Note that each topic starts with an introduction which references why the topic is important. At the end of the introduction, a table spells out specifically which driver behaviors or tasks are related to that topic and might be candidates for onboard monitoring. A section on driver feedback recommendations discusses the various options on how driver feedback might be provided, listing the pros and cons when multiple design options are available and, where appropriate, discussing the interfaces of specific COTS subsystems that have been referenced on the topic.

The additional discussion subsection describes and references some of the key literature on the topic. Although performance measure options and COTS devices have been listed when

available, the discussion and recommendations have been kept at a high level as the purpose of this section is to provide an unconstrained exhibit of potential system features.

The subsection entitled “cross references” merely points the reader to other topics which might be related or utilize similar performance measures. As an example, lane position might relate to both distraction and fatigue. Finally, the key references subsection lists all of the references used in writing the section on the topic.

### **2.5.1 Monitoring Vehicle Speed**

#### Introduction:

From Section 2.2, there are several ways that speed could be driver behavior failure with a lane departure and rear-end crashes. Speeding, under the banner of aggressive driving, was also listed as one of the top concerns among industry experts (Knipling, Hickman, and Bergoffen, 2003) and by long and short haul truck drivers by (Roetting, Haung, and McDevitt, 2005). Candidate driver behaviors for onboard monitoring are listed below:

#### **Candidate Driver Behaviors for Onboard Monitoring**

1. Vehicle speed relative to roadway speed limit
2. Vehicle speed relative to safe curve speed
3. Vehicle speed relative to roadway (weather) conditions
4. Vehicle speed relative to night visibility (headlight sight distance)
5. Vehicle speed relative to traffic flow

#### Driver Feedback Recommendations:

#### **Recommended Driver Feedback Designs**

1. Delayed or off-line feedback with summary statistics
2. Real-time feedback in the form of a series of speed warning or status lights
3. Engine speed limiters

Three driver feedback options have been presented both in order of complexity and in order of the aggressiveness of the intervention. A vehicle speed monitoring system could be effectively

built around any or all of these driver feedback schemes. Realistically, the driver already receives feedback about vehicle speed from the speedometer and feedback about the speed limit and recommended curve speeds from signs on the roadside. For these reasons, off-line or delayed feedback could be justified.

As long as the information is available, an argument could also be made to provide the driver with some indication or comparison of current and recommended speed, so long as it is presented in a way that does not distract the driver. While perhaps the best system utilizing this method of feedback might include concepts such as a reconfigurable speedometer, simpler implementations could include a series of speed warning or status lights which illuminate when the recommended speed has been exceeded. At least in the case of curve over speed, system design consideration must be given to the overall goal of safety. If the information is available to monitor curve speed compliance, should it also be coupled with a curve over speed warning system to aid the driver?

Conceivably, the strictest and most aggressive form of driver speed monitoring and feedback would be to electronically disallow the vehicle from traveling above the recommended speed. While systems exist currently to simply limit the overall top speed of a vehicle, there are many more human factors issues with the implementation of a dynamic speed limiting system. Although this feedback method may eventually be an option, it would likely be coupled with visual indicators, and the number of implementation questions for which there is currently little or no research would make this option challenging.

One alternative that has not been recommended based on the current research is the use of force feedback on the accelerator pedal to influence driver speed selection. While Várhelyi, Hjalmdahl, Hydén, and Draskóczy (2004) have reported some success in Sweden using accelerator pedal feedback for speed limit compliance, other studies currently being conducted on the topic of curve over speed have preliminarily reported limited effectiveness and sometimes even adverse effects when using accelerator pedal feedback. More conclusive research on this topic will likely be released in the next few years and should be carefully reviewed before recommending accelerator pedal feedback as an option.

### Additional Discussion:

In 1998 the Transportation Research Board published Special Report 254, a review of current knowledge and literature on the topic of speed and safety. This report, along with a more recent paper from the Netherlands (Aarts and van Shagen, 2006), summarized that there is evidence, though not conclusive, that both increasing speed and increasing speed disparity can be associated with crash involvement and crash severity for certain crash types. As an example, increased speed can be associated with increases in single-vehicle or ran-off-the-road types of crashes. At higher speeds, deviations from the average traffic speed has been shown to increase crash probability. In all cases, crash and injury severity rises sharply with increased speed, which simply reflects the laws of physics which state the energy of an impact will be proportional to the square of the speed.

### Cross References:

See Section 2.5.2 (Following Distance) - Monitoring vehicle speed relative to traffic flow is related to rear-end collisions and may also be related to following distance.

### Key References:

Aarts, L. and van Shagen, I. (2006). Driving Speed and the Risk of Road Crashes: A Review. *Accident Analysis and Prevention*. 38, 315-224.

Knipling, R., Hickman, J., and Bergoffen, G. (2003). Commercial Truck and Bus Safety Synthesis Program: Synthesis 1 - Effective Commercial Truck and Bus Safety Management Techniques. Washington D.C.: Transportation Research Board.

Roetting, M., Huang, Y., McDevitt, J.R., Melton, D., Smith, G.S. (2005). Feedback by technology: Attitudes and opinions of truck drivers. *Transportation Research Part F*. 8, 277-297.

Transportation Research Board (1998). *Managing Speed: Review of Current Practice for Setting and Enforcing Speed Limits (Special Report 254)*. Washington D.C.: National Research Council.

Várhelyi, A., Hjalmdahl, M., Hydén, C., and Draskóczy, M. (2004). Effects of an active accelerator pedal on driver behaviour and traffic safety after long-term use in urban areas. *Accident Analysis and Prevention*. 36, 729-737.

## 2.5.2 Monitoring Following Distance

### Introduction:

The large truck crash causation study (LTCCS) found that rear-end collisions accounted for approximately 28 percent of the crashes caused by truck drivers. Table 2-13 lists following too close as a potential driving behavior failure which could contribute to a rear-end crash. Following too close was also listed under the banner of aggressive driving which was one of the top concerns among industry experts (Knipling, Hickman, and Bergoffen, 2003) and by long and short haul truck drivers by (Roetting, Haung, and McDevitt, 2005).

### **Candidate Driver Behaviors for Onboard Monitoring**

1. Following too close for travel speed and trailer loading
2. Following too close for weather conditions

### Driver Feedback Recommendations:

### **Recommended Driver Feedback Designs**

1. Delayed or off-line feedback with summary statistics
2. Real-time feedback in the form of a warning/status light
3. Forward collision warning system

Effective feedback for following distance could be provided in the form of delayed summary feedback, a real-time following too close warning/status light, or a fully functional forward collision warning system. Real-time feedback on this parameter is highly recommended as Shinar and Schechtman (2001) have effectively shown that providing real-time following distance feedback to drivers has a lasting improvement on inter-vehicular distance.

System design consideration must also be given to the overall goal of safety. If the information is available to monitor following distance, it should also be coupled with a fully functional forward collision warning system to aid the driver, especially since it was found in earlier research that the more tangible benefits the system could provide, the more likely drivers would accept the system.

Additionally, there will likely be an issue with handling vehicle cut-ins, which are a common problem around heavy trucks. Specifically, drivers will likely be unhappy if their feedback penalizes them for following too close when an event was not considered their fault.

Additional Discussion:

In Table 2-17, stopping distances required by both cars and trucks for various initial speeds are given. These stopping distances are based on typical deceleration rates as reported by Radlinski (1987) for a variety of light and heavy vehicles; however, these numbers are on the extreme side as maximum vehicle braking capabilities often exceed the limit drivers are willing to push them. From the required stopping distances, a safe following distance can be computed by subtracting a typical car’s stopping distance from the truck’s stopping distance and adding buffers for air brake lag and driver reaction time. Air brakes typically take a half-second to build up pressure before braking can start; however, some models of truck may take up to a full second. The typical value reported for driver perception-response time is 1.5 seconds which was the 95 percentile response time found in the CAMP project (Kiefer, et al., 1999) for a reasonably attentive driver.

**Table 2-17. Safe Following Distance by Speed for Cars and Trucks**

Speed (mph)	Speed (m/s)	Car Stopping Distance (m)	Truck Stopping Distance (m)		Safe Following Distance (m)	Safe Following Distance (s)
			Min (m)	Max (m)		
10	4.5	1.5	2.2	2.7	10.1	2.3
20	8.9	6.1	8.7	10.8	22.6	2.5
30	13.5	13.6	19.5	24.3	37.5	2.8
40	17.9	24.2	34.8	43.2	54.7	3.1
50	22.4	37.8	54.3	67.5	74.4	3.3
60	26.8	54.5	78.2	97.2	96.4	3.6
70	31.3	74.2	106.4	132.3	120.7	3.9

Factors such as trailer loading and weather conditions may also be important when determining the safe following distance; however, these factors were not included in this Table 2-14. Additionally, some fine tuning will likely be necessary to adjust safe following distances based on typical driver preferences and to make sure that opportunity for even more hazardous situations aren’t created (such as opportunity for vehicle cut-ins).



Eaton (<http://www.vorad.com/>) is one of the leading COTS manufacturers of commercial collision warning systems, and they currently manufacture the VORAD radar-based Forward Collision Warning System specifically designed for trucks. Delphi also has a COTS forward collision warning system called Forewarn (<http://delphi.com/manufacturers/cv/safesecure/>).

#### Cross References:

See Section 2.5.1 (Vehicle Speed) - Following distance is related to rear-end collisions and another metric which may also be related is vehicle speed relative to traffic flow.

See Section 2.5.3 (Attention) - Safe following distances are based on the attentive driver. Although rear-end collisions were one of the three major crash scenarios found in the LTCCS, intentionally following too close was only a factor in maybe 4 percent of crashes, and inattention was to blame far more often.

See Section 2.5.4 (Hard Braking Incidents) - Same as above.

#### Key References:

Kiefer, R, LeBlanc, D., Palmer, M., Salinger, J, Deering, R., & Shulman, M. (1999). Development and Validation of Functional Definitions and Evaluation Procedures for Collision Warning/Avoidance Systems (NHTSA Technical Report DOT HS 808 964). Crash Avoidance Metrics Partnership (CAMP), Farmington Hills, MI.

Radlinski, R. (1987). Braking Performance of Heavy U.S. Vehicles (SAE Paper No. 870492). SAE Transactions. Warrendale, PA: SAE International.

Shinar, D. and Schechtman, E. (2001). Headway feedback improves inter-vehicular distance: a field study. Human Factors. 44, 474-481.

### 2.5.3 Monitoring Attention

#### Introduction:

The Large Truck Crash Causation Study (LTCCS) found that nearly 46 percent of the two-vehicle crashes caused by trucks were primarily attributed to inattention or distractions (See Table 2-2). Overall, inattention or distraction was an associated or related factor in over 25 percent of crashes. In Table 2-4, factors related to distraction were given as potential behavioral failure mechanisms for all of the major types of truck crashes including single vehicle ran-off-the-road crashes, head-on collisions, intersection crashes, and rear-end collisions.

#### **Candidate Driver Behaviors for Onboard Monitoring**

1. Driver eyes-off-the-road time
2. Driver eye scanning patterns
3. Surrogate measures (see hard braking incidents, lane position and lane keeping)

#### Driver Feedback Recommendations:

#### **Recommended Driver Feedback Designs**

1. Delayed or off-line feedback with summary statistics
2. Real-time feedback of eyes-off-the-road time and traveled distance
3. Supplement to a collision warning system

Feedback for driver attention monitoring could be provided in the form of delayed summary feedback or possibly through a real-time display. Inspiration for a real-time eyes-off-the-road feedback device might come from the interface developed by Attention Technologies for their drowsy driver detection system (Ayoob, Grace, and Steinfeld, 2003). In this system eyes closed time along with distance traveled in that time is fed back to the driver.

Recent news releases from Japan have described a driver attention monitoring system currently being researched by Toyota. The system recognizes facial orientation to establish probable eyes-off-the-road events to supplement collision and pre-crash warning systems. If the driver is found to be looking away from the road, the forward collision warning could be given sooner and stronger in an attempt to get the driver back to being focused on the road ahead. Thus, in the

pursuit of overall system safety, if the information is available from monitoring eyes-off-the-road time and following distance, should the monitoring feedback also be coupled with collision warning systems to aid the driver?

Additional Discussion:

Two direct measures of driver attention (or inattention) have been proposed and discussed in the literature: (1) eyes-off-the-road time and (2) changes in the driver's scanning patterns. Eyes-off-the-road time has generally been referenced in the context of the design of in-vehicle devices, specifically, navigation systems. Green (1998) summarizes links that have been found in the literature between eyes-off-the-road time (glance duration and frequency) and lane departures. More recently, Victor, Harbluk, and Engström (2005) have shown that changes in eye scanning patterns may also indicate distraction or inattention. Specifically, when attention becomes divided between two tasks, such as driving and an in-vehicle task, the driver's scanning pattern of the road ahead becomes more tunneled.

While direct measures of attention tend to focus on the driver's visual attention, indirect or surrogate measures of attention might include looking at the outcome or resultant. Potential indications that a driver is or has been distracted might include hard braking incidents or excessive weaving (poor lane position control).

### Cross References:

See Section 2.5.2 (Following Distance) - Rear-end collisions are a typical byproduct of an attention failure, and the typical countermeasure is a forward collision warning system as discussed in Section 2.5.2.

See Section 2.5.4 (Hard Braking Incidents) - Hard braking incidents may provide a surrogate measure for monitoring attention.

See Section 2.5.5 (Lane Position) - Ran-off-the-road crashes are a typical byproduct of an attention failure, and the typical countermeasure is a lane departure warning system as discussed in Section 2.5.5. Lane position may provide a possible surrogate measure for monitoring attention.

### Key References:

Ayoob, E., Grace, R., and Steinfeld, A. (2003). A user-centered drowsy-driver detection and warning system. Proceedings of the 2003 conference on Designing for user experiences. New York, NY: Associations for Computing Machinery (ACM).

Green, P. (1998). Visual and Task Demands of Driver Information Systems (Technical Report UMTRI-98-16). Ann Arbor, MI: The University of Michigan Transportation Research Institute.

Victor, T., Harbluk, J., and Engström, J. (2005). Sensitivity of eye-movement measures to in-vehicle task difficulty. Transportation Research Part F. 8: 167-190.

## 2.5.4 Monitoring Hard Braking Incidents

### Introduction:

Rear-end crashes (Table 2-5) can potentially result from many behavioral failures such as distraction, falling asleep, failures to anticipate changes in traffic, and failures to react to vehicle cut-ins. Since many of these behaviors are difficult to monitor directly, one potential solution is to monitor, record, and investigate near misses which can be defined as hard braking events.

### **Candidate Driver Behaviors for Onboard Monitoring**

1. The frequency of hard braking events
2. The engineering details and forward looking video surrounding the event

### Driver Feedback Recommendations:

### **Recommended Driver Feedback Designs**

1. Delayed or off-line feedback with summary statistics

Feedback for near misses or hard braking events is best provided off-line with summary statistics. A real-time feedback system for these events would not be recommended since the driver would already be aware of the event, and the event would be completed by the time the system could react. Even if the system could detect and react during a hard braking event, it would not be recommended because the driver's attention should be focused on controlling the vehicle at that point, not on receiving feedback. Useful feedback on hard braking events comes from reviewing event frequency over time. While the driver may be aware of an individual braking event, the driver may not realize just how many situations he or she gets into that require hard braking during a specific time period or how that compares to other drivers.

### Additional Discussion:

The XATA, the Accident Prevention Plus, and the DriveCAM onboard monitoring COTS systems record hard braking events. The DriveCAM system also records audio and video both before and after the incident.

### Cross References:

See Section 2.5.2 (Following Distance) - Hard braking incidents may be related to rear-end collisions which are also related to following distance.

See Section 2.5.3 (Attention) - Hard braking incidents may provide a surrogate measure for attention.

See Section 2.5.7 (Incidents) - Hard braking incidents are just one of many incidents that might be monitored and recorded.

### Key References:

None.

## **2.5.5 Monitoring Lane Position (to include Lane Departure)**

As described in Section 2.2, lane departures was one of the three major critical reasons for truck crashes as identified in the Large Truck Crash Causation Study (LTCCS) which can result in ran-off-the road crashes, head-on collisions, and lane change or merge crashes. Although poor vehicle control only accounted for about 5 percent of truck caused crashes (Table 2), lane position might also provide a surrogate measure of driver inattention, which can also lead to crashes.

Introduction:

**Candidate Driver Behaviors for Onboard Monitoring**

1. Lane position
2. Steering inputs

Driver Feedback Recommendations:

**Recommended Driver Feedback Designs**

1. Delayed or off-line feedback with summary statistics
2. A lane departure warning system

Feedback on lane position would best be provided off-line with summary statistics and real-time through a lane departure warning system. Most measures of lane keeping performance are either normalized over time or for the express purpose of predicting a lane departure. Providing lane keeping performance feedback after a lane departure would be similar to providing feedback after a hard braking event. The driver already knows that an event has occurred and the feedback could potentially be distracting. What the driver may not realize is how many lane departure events he becomes involved in and how this compares to other drivers.

Real-time feedback would best be provided through a predictive lane departure warning system. Iteris (<http://www.iteris.com/>) is one of the leading COTS manufacturers of commercial truck lane departure warning systems. Delphi also has the Forewarn Lane Departure Warning system (<http://delphi.com/manufacturers/cv/safesecure/>).

Additional Discussion:

Three direct measures of lane keeping performance have generally been proposed and discussed in the literature: (1) the number of lane departures per VMT, (2) the standard deviation of lane position (over some time window), and (3) time-to-line crossing (TLC). The standard deviation or variance of lane position has generally been reported in the literature as a measure of lane keeping performance. However, it is generally used to compare one condition to another, and

absolute safety criteria has never been defined. Green, et al. (2003) provides a good summary of how the standard deviation of lane position has been used in the past.

Time-to-line crossing was first suggested by Godthelp, Milgram, Blaauw (1984), and more recently in a paper comparing the merits of various calculation methods by van Winsum, Brookhuis, and de Waard (2000).

Two indirect measures of lane keeping performance have been proposed and discussed in the literature: (1) steering wheel reversals and (2) steering entropy ( $H_p$ ). Steering wheel reversals had been proposed as a measure of workload, but it was not found to be a very sensitive measure. Steering entropy is a promising measure that has been recently proposed to quantify drivers' efforts to maintain lateral safety margins (Boer, 2001, and Boer, et al., 2005). Steering entropy was originally developed as a measure that might be used to quantify reduced or diverted attention or changes in the driver's workload, and has recently also been proposed as a measure of fatigue (Paul, Boyle, Boer, Tippin, and Rizzo, 2005).



### Cross References:

See Section 2.5.3 (Attention) - Lane position may provide a possible surrogate measure for monitoring attention.

See Section 2.5.6 (Lane Changes) - While Section 2.4.5 covers unintentional lane departures, Section 2.5.6 covers intentional lane departures.

### Key References:

Boer, E. (2001). Behavioral Entropy as a Measure of Driving Performance. Proceedings of the First International Driving Symposium on Human Factors in Driver Assessment, Training and Vehicle Design. Iowa City, IA: The University of Iowa. [Available Online at <http://ppc.uiowa.edu/driving-assessment/>]

Boer, E., Rakauskas, M., Ward, N., and Goodrich, M. (2005). Steering Entropy Revisited. Proceedings of the Third International Driving Symposium on Human Factors in Driver Assessment, Training and Vehicle Design. Iowa City, IA: The University of Iowa. [Available Online at <http://ppc.uiowa.edu/driving-assessment/>]

Godthelp, J., Milgram, J., Blaauw, G. (1984). The development of a time-related measure to describe driving strategy. *Human Factors*. 26, 257–268.

Green, P., Cullinane, B., Zylstra, B., and Smith, D. (2003). Typical Values for Driving Performance with Emphasis on the Standard Deviation of Lane Position: A Summary of Literature (Technical Report UMTRI-2003-42). Ann Arbor, MI: The University of Michigan Transportation Research Institute.

Paul, A., Boyle, L., Boer, E., Tippin, J., and Rizzo, M. (2005). Steering Entropy Changes as a Function of Microsleeps. Proceedings of the Third International Driving Symposium on

Human Factors in Driver Assessment, Training and Vehicle Design. Iowa City, IA: The University of Iowa. [Available Online at <http://ppc.uiowa.edu/driving-assessment/>]

van Winsum, W., Brookhuis, K., and de Waard, D. (2000). A comparison of different ways to approximate time-to-line crossing (TLC) during car driving. *Accident Analysis and Prevention*. 32, 47-56.

### **2.5.6 Monitoring Lane Changes**

#### Introduction:

As described in Table 2-3, lane change and merge related crashes were grouped under lane departures as a causal factor. In most of the other analyses that were reviewed, lane change crashes were typically combined with several other types of crashes; however, lateral encroachment during lane changes often due to improper mirror adjustment was listed as an at-risk driving behavior which is one of the top concerns among industry experts (Knipling, Hickman, and Bergoffen, 2003).

#### **Candidate Driver Behaviors for Onboard Monitoring**

1. Use of turn signal before merging
2. Eye glances to the mirror before merging
3. Did the driver adjust the mirrors before departing the yard
4. Side or blind spot vehicle presence or position during lane changes

#### Driver Feedback Recommendations:

#### **Recommended Driver Feedback Designs**

1. Delayed or off-line feedback with summary statistics
2. A side object awareness and collision avoidance system

Feedback on items such as turn signal use, mirror adjustments, and eye glances would best be provided off-line with summary statistics. If real-time monitoring of side or blind spot vehicles is possible, feedback would best be provided through a side object awareness and collision avoidance system.

### Additional Discussion:

There has been much research on side object detection and side collision avoidance systems resulting from three NHTSA initiatives on the topic. Descriptions of these programs can be found on the NHTSA web site, link as follows: (<http://www-nrd.nhtsa.dot.gov/departments/nrd-12/11rev.html>). More recently, an SAE paper which may be of relevance (Smith, et al., 2003) discussed the feasibility of modeling lane-change performance using four states.

Eaton (<http://www.vorad.com/>) is one of the leading COTS manufacturers of commercial collision warning systems. The VORAD BlindSpotter is a currently available radar based side object detection system for truck applications. Delphi also has the Forewarn Radar Side Alert system (<http://delphi.com/manufacturers/cv/safesecure/>).

### Cross References:

See Section 2.5.5 (Lane Position) - While Section 2.4.6 covers intentional lane changes, section 2.5.5 covers unintentional lane changes (lane departures).

### Key References:

Knipling, R., Hickman, J., and Bergoffen, G. (2003). Commercial Truck and Bus Safety Synthesis Program: Synthesis 1 - Effective Commercial Truck and Bus Safety Management Techniques. Washington D.C.: Transportation Research Board.

Smith, D., Glassco, R., Chang, J., and Cohen, D. (2003). Feasibility of Modeling Lane-Change Performance (SAE Paper 2003-01-0280). Warrendale, PA: The Society of Automotive Engineers.

## 2.5.7 Monitoring and Recording Incidents

### Introduction:

Industry experts (Knippling, Hickman, and Bergoffen, 2003) and truck drivers (Roetting, Huang, and McDevitt, 2005) both ranked several fuzzy behavioral concepts such as defensive driving skills, space management, anticipating traffic changes, and being ready to avoid the mistakes of other drivers as critical safety behaviors. Unfortunately, most of these concepts are difficult to measure directly, so one potential solution is to monitor, record, investigate, and teach drivers these skills through incident investigation.

### **Candidate Driver Behaviors for Onboard Monitoring**

1. Hard braking incidents
2. Hard steering incidents
3. Close following distances (vehicle cut-ins)
4. Collision warning system activations
5. Crashes
6. Forward and/or driver video during the incident

### Driver Feedback Recommendations:

### **Recommended Driver Feedback Designs**

1. Delayed or off-line feedback

Feedback on the monitoring and recording of incidents would likely need to be part of a carefully constructed program that was presented to drivers in a non-threatening way. The goal of the program would be to have drivers examine and review near misses and other violent maneuvers in such a way that they might learn the skills necessary to avoid such incidents in the future.

The resulting analysis will be most effective as more and more data can be included about the incident, especially forward looking video and video of the driver at the time. Drivers will relate to and recall the details of the incident much better if video is provided. The inclusion of forward-looking video may be able to be sold as protection against liability in the case of a crash,

since most crashes involving large trucks are not the fault of the truck driver. However, video of the driver may prove a difficult sell given privacy concerns.

#### Additional Discussion:

Several of the reviewed COTS devices record or flag various events. XATA records rapid stops and contains tools to reconstruct accidents with black box data. The Accident Prevention Plus system records vehicle data for 50 seconds before and 20 seconds after a crash, and the DriveCam system records both vehicle data and external video both before and after large g-force events or crashes. Finally, Eaton (<http://www.vorad.com/>) makes the VORAD Accident Reconstruction Technology, a product which combines vehicle data with the data received from a VORAD Forward Collision Warning system to graphically reconstruct crashes.

#### Cross References:

See Section 2.5.4 (Hard Braking Incidents) - Hard braking incidents are discussed in detail in Section 2.5.4.

#### Key References:

Knipling, R., Hickman, J., and Bergoffen, G. (2003). Commercial Truck and Bus Safety Synthesis Program: Synthesis 1 - Effective Commercial Truck and Bus Safety Management Techniques. Washington D.C.: Transportation Research Board.

Roetting, M., Huang, Y., McDevitt, J.R., Melton, D., Smith, G.S. (2005). Feedback by technology: Attitudes and opinions of truck drivers. Transportation Research Part F 8. pp. 277-297.

## 2.5.8 Monitoring Fatigue

### Introduction:

Industry experts ranked fatigue or drowsy driving as number six out of their top nine safety concerns (Knipling, Hickman, and Bergoffen, 2003), and drivers ranked it as number five out of their top ten (Roetting, Huang, and McDevitt, 2005). However, European crash data has shown that fatigue was a causal factor in only 5.3 percent of truck crashes (Häkkinen and Summala, 2001), and Large Truck Crash Causation Study (LTCCS) found similar results, suggesting that only 4 percent of crashes could be attributed to sleep or sleep related to illness.

### **Candidate Driver Behaviors for Onboard Monitoring**

1. Driver eye movements
2. Lane position

### Driver Feedback Recommendations:

### **Recommended Driver Feedback Designs**

1. Real-time drowsy driver detection and warning system

Fatigue or drowsy driving can result in an immediate threat if left unchecked; short breaks, naps, and even a simple cup of coffee at the right moment can be a highly effective countermeasure to fatigue as our bodies tend to work in cycles or rhythms. The goal of any fatigue feedback system should be first and foremost to assist the driver in determining when best to stop and take a break. A second goal might be to educate or convince a driver that a break is necessary, and finally, the feedback should be able to warn or wake a driver engaged in microsleeps. One novel feedback interface exists on the Copilot driver fatigue monitoring system by Attention Technologies (<http://www.attentiontechnology.com/>), whose user-centered design is detailed in Ayoob, Grace, and Steinfeld (2003).

### Additional Discussion:

There is distinction that should be made between the terms and concepts of fatigue and drowsy driving. Fatigue, which is often lumped together with drowsy driving on surveys, may carry certain connotations which could affect how highly it has been rated as a problem by drivers compared to the actual crash statistics. Fatigue represents an entire continuum which ends in drowsy driving. Noticeable changes occur and increase with the onset of fatigue such as feelings of tiredness, a lack of the ability to focus attention, decreased working memory, slowed reactions times, and tunnel vision in eye scan patterns. Some of the indicators were specifically reported with solo long-haul truck drivers in Hartley, et al. (1994). A recent paper by Williamson, et al. (2001) further detailed and characterized some of the cognitive and motor skill performance decrements that can be associated with fatigue. Moderate stages of fatigue may mimic distracted driving, resulting in a general, overall, increased crash risk. This is generally believed to be one of the reasons why crashes occur more frequently during evening commutes rather than during morning commutes.

As fatigue slowly builds, sometimes over a series of hours, it becomes drowsy driving which can be characterized by extreme tunnel vision and microsleeps. One fatigue or drowsy driving detection method or measure that has been researched, validated, and extensively tested is PERCLOS. Simply put, PERCLOS is the percentage of eye closure, and some of the early work on the measure can be found in Weireille, et al. (1994) and Dinges, et al. (1998). At least one COTS fatigue monitoring device utilizing PERCLOS is available, the Copilot which is made by Attention Technologies (<http://www.attentiontechnology.com/>).

Steering entropy, a measure of lane keeping performance, has also been recently proposed as a surrogate measure for fatigue (Paul, Boyle, Boer, Tippin, and Rizzo, 2005).

### Cross References:

See Section 2.5.2 (Following Distance) - One possible result of driver's falling asleep at the wheel is a rear-end collision, and a forward collision warning system may also prove a useful countermeasure.

See Section 2.5.3 (Attention) - The stages of fatigue can result in similar performance decrements as seen with inattention, so similar monitoring techniques may prove useful to both.

See Section 2.5.5 (Lane Position) - One likely result of driver's falling asleep at the wheel is a lane departure, so lane position may be a surrogate for drowsy driver detection, and a lane departure warning system may also prove a useful countermeasure.

See Section 2.4.9 (Hours of Service) - One surrogate to measuring fatigue directly is monitoring hours of service.

### Key References:

Ayoob, E., Grace, R., and Steinfeld, A. (2003). A user-centered drowsy-driver detection and warning system. Proceedings of the 2003 conference on Designing for user experiences. New York, NY: Associations for Computing Machinery (ACM).

Dinges, D., Mallis, M., Maislin, G., Powell, J. (1998). Evaluation of Techniques for Ocular Measurement as an Index of Fatigue and as the Basis for Alertness Management (DOT HS 808 762). Washington, DC: National Highway Traffic Safety Administration.

Häkkinen, H. and Summala, H. (2001). Fatal traffic accidents among trailer truck drivers and accident causes as viewed by other truck drivers. Accident Analysis and Prevention. 33, 187-196.



- Hartley, L.R., Arnold, P.K., Smythe, G., and Hansen, J. (1994). Indicators of fatigue in truck drivers. *Applied Ergonomics*. 143-156.
- Knipling, R., Hickman, J., and Bergoffen, G. (2003). Commercial Truck and Bus Safety Synthesis Program: Synthesis 1 - Effective Commercial Truck and Bus Safety Management Techniques. Washington D.C.: Transportation Research Board.
- Paul, A., Boyle, L., Boer, E., Tippin, J., and Rizzo, M. (2005). Steering Entropy Changes as a Function of Microsleeps. *Proceedings of the Third International Driving Symposium on Human Factors in Driver Assessment, Training and Vehicle Design*. Iowa City, IA: The University of Iowa. [Available Online at <http://ppc.uiowa.edu/driving-assessment/>]
- Roetting, M., Huang, Y., McDevitt, J.R., Melton, D., Smith, G.S. (2005). Feedback by technology: Attitudes and opinions of truck drivers. *Transportation Research Part F* 8. pp. 277-297.
- Wierwille, W., Ellsworth, L., Wreggit, S., Fairbanks, R., Kirn, C. (1994). Research on vehicle based driver status/performance monitoring: development, validation, and refinement of algorithms for detection of driver drowsiness (DOT HS 808 247). Washington, DC: National Highway Traffic Safety Administration.
- Williamson, A., Feyer, A., Mattick, R., Friswell, R., Finlay-Brown, S. (2001). Developing measures of fatigue using an alcohol comparison to validate the effects of fatigue on performance. *Accident Analysis and Prevention*. 33, 313-326.

## 2.5.9 Monitoring Hours of Service

### Introduction:

The maximum hours of service (HOS) a driver can perform is specified in both Federal and State regulations. These limits have been placed, in part, to guard against driver fatigue. Drivers are required to keep logs to determine compliance the mandatory hours of service requirements, and the requirements for an automatic monitoring system have already been laid out in both the federal and the state codes which are listed below. It is noted that there are many nuances in hours of service rules, to include, for example, the restart provision. The final OBMS system should be carefully designed to accommodate this and other nuances to the rule and will include additional considerations such as the amount of time left before a HOS violation.

#### **Federal Regulation CFR III-395.15 of Title 49: Requirements for Automatic On-Board Monitoring of Hours of Service**

1. Duty status: off duty, sleeper berth, driving, or on-duty not driving;
2. Date
3. Total miles driven today
4. Truck or tractor and trailer number
5. Name of carrier
6. Main office address
7. 24-hour period starting time
8. Name of co-driver
9. Total hours
10. Shipping document number or name of shipper and commodity
11. For each change of duty status, the name of the city, town, or village, with State shall be recorded.
12. Amount of time remaining before exceeding hours of service.

**California Code Section 1213.2:  
Requirements for Automatic On-Board Monitoring of Hours of Service**

1. Engine use
2. Road speed
3. Miles driven
4. Date
4. Time of day
6. Duty status
7. Multiple drivers

Driver Feedback Recommendations:

**California Code Section 1213.2  
Feedback Requirements for Automatic On-Board Monitoring of Hours of Service**

Automatic on-board recording devices should produce an electronic display or printout (on demand) of a driver's hours of service, showing the time, sequence, and location of duty status changes including the driver's starting time at the beginning of each day.

Automatic on-board recording devices with electronic displays shall have the capability of displaying the following:

1. Driver's total hours of driving
2. Total hours on duty today
3. Total miles driven today
4. The sequential changes in duty status, and the times and locations where changes occurred for each driver.

Additional Discussion:

The maximum hours of operation as defined by federal and state codes and regulations are compared below. Federal regulations apply for interstate travel, but the California State code, which is somewhat less stringent, applies for intrastate travel. In addition to the federal and state regulations, the Transportation Research Board has published a guide on hours of service and fatigue management techniques (Brock, Golembiewski, Krueger, Daecher, Bishop, and Bergoffen, 2005).

<p>CFR Title 49, Subtitle 3, Chapter III, Section 395.3</p> <p>(1) May drive a maximum of 11 hours after 10 consecutive hours off duty.</p> <p>(2) May not drive beyond the 14<sup>th</sup> hour after coming on duty, following 10 consecutive hours off duty.</p> <p>(3) May not drive after 60/70 hours on duty in 7/8 consecutive days.</p> <p>(4) CMV drivers using a sleeper berth provision must take at least 8 consecutive hours in the sleeper berth, plus 2 consecutive hours either in the sleeper berth, off duty, or any combination of the two.</p>	<p>In California Vehicle Code Section 34501.2:</p> <p>(1) The maximum driving time within a work period shall be 12 hours for a driver of a truck or a truck tractor, except for a driver of a tank vehicle with a capacity of more than 500 gallons transporting flammable liquid, who shall not drive for more than 10 hours within a work period.</p> <p>(2) No motor carrier shall permit or require a driver to drive, nor shall any driver drive, for any period after having been on duty for 80 hours in any consecutive 8 days.</p> <p>(3) Exceptions include drivers hired by:</p> <ul style="list-style-type: none"> <li>a. Water, electrical, and gas corporations.</li> <li>b. Governmental fire and law enforcement departments.</li> <li>c. Agricultural carriers (different restrictions apply).</li> </ul>
--	---

Electronic onboard recorders (EOBR) have been available for completing records of duty status (RODS) fulfilling operator hours of service (HOS) regulations since 1988. Three current COTS devices which are currently on the market are described below.

Company	Features					
	CFR49 Part 395.15 Compliance	GPS-based Location Recording	Wireless Communication	Vehicle Speed	Two-way Text Message	Fuel Consumption Evaluation
Karta	×	×	×	×	×	
Nextel	×	×	×	×	×	×
Tripmaster	×	×		×		×

Karta's TransTRAK (also known as planetTRAKS) system is a vehicle tracking system that is designed to deliver real-time vehicle location, speed, distance monitoring, and data on numerous other vehicle events. The bonus features of this system consist of: (1) GPS-based positioning,

routing, and “geofences”, (2) asset tracking, and (3) two-way text messaging system. This system can automate the collection and reporting of driver duty status information.

Nextel’s XORA system is a JAVA- and GPS-enabled phone that is designed to deliver real-time user location, speed, distance monitoring. The bonus features of this system consist of: (1) GPS-based positioning, routing, and “geofences” and (2) phone alerts for HOS violations. The advantage of this system is that the EOBR functions have been built into a cell phone.

The purpose of Tripmaster’s suite of products is to assist in basic federal compliance reporting requirements, such as computing fuel and mileage tax and driver logs. The additional features of this system include: (1) GPS-based positioning and (2) over-speed continuous warning beeper.

#### Cross References:

See Section 2.5.8 (Fatigue) - Monitoring hours of service may be considered surrogate to measuring fatigue directly.

#### Key References:

Brock, J., Golembiewski, G., Krueger, G., Daecher, C., Bishop, R., Bergoffen, G. (2005). Commercial Truck and Bus Safety Synthesis Program: Synthesis 7- Motorcoach Industry Hours of Service and Fatigue Management Techniques. Washington D.C.: Transportation Research Board.

California Code of Regulations, Title 13 Motor Vehicles, Division 2 Dept. of CHP, Chapter 6.5 Motor Carrier Safety, Article 3 General Driving Requirements, Section 1213.2 Automatic Onboard Recording Devices.

California Vehicle Code, Division 14.8 Safety Regulations, Section 34501.2 Limitations: Driving Hours.

Code of Federal Regulations, Title 49, Subtitle 3, Chapter III, Sections 395.3 and 395.15.

Nextel's XORA website: <http://www.nextel.com/en/solutions/gps/xora.shtml>

planetTRAKS website: <http://www.planetraks.com/>

Tripmaster's website: <http://www.tripmaster.com/>

## **2.5.10 Monitoring Behaviors at Intersections**

### Introduction:

The large truck crash causation study (LTCCS) found that intersection related crashes accounted for approximately 27 percent of the crashes caused by truck drivers, which was the third largest category of critical events. As described in Section 3.2 intersection crashes can result from poor scanning, failures in perception, and poor decisions. The LTCCS, in Table 2-2, found that, overall, 46 percent of the crashes were primarily the result of inattention or distraction, and 36 percent were primarily caused by driver decisions (misjudgments). Unfortunately, without knowing exact vehicle locations, it's very difficult to monitor or critique driver decisions. While this may become possible in the future with the advent of vehicle-to-vehicle (V2V) and vehicle-to-infrastructure (V2I) communications, several near term possibilities for intersection behavior monitoring are listed below.

### **Candidate Driver Behaviors for Onboard Monitoring**

1. Stopping for stop signs
2. Stopping for red lights
3. Eye glance patterns, i.e., checking for cross traffic when leaving a 2-way stop sign

## Driver Feedback Recommendations:

### **Recommended Driver Feedback Designs**

1. Delayed or off-line feedback
2. Real-time stop sign or red light violation warning system

Feedback for intersection behavior monitoring would best be provided through off-line with summary statistics. A real-time feedback system for these events would not be recommended since the driver would already be aware of the event, and the event would be completed by the time the system could react. Useful feedback on these events may come from reviewing event frequency over time. While the driver may be aware of an individual event, the driver may not realize how often those events happen.

Alternatively, there has been recent and ongoing research (FHWA, 2004) on the topic of stop sign and red light violation warnings. This research should eventually result in specifications on how to predict violations and provide the driver with real-time feedback in the form of a warning system.

In the OBMS prototype implementation, intersection warning was not provided due to difficulty in acquiring the correct map database with stop signs and traffic signals. However, this will be an open topic in the ensuing FOT.

### Additional Discussion:

While enhanced maps might provide the locations of stop signs and traffic signals, detecting the current phase of the traffic signal can probably only be achieved through video detection and processing. In there near future, there may be the possibility of getting traffic signal state automatically through V2I communications.

Checking eye glance scanning patterns, although possible, would probably provide little useful information. Intersection scanning is complex, and not well understood. Additionally, scanning

does not necessarily result in seeing or perceiving, as is evident by the crash causation category of “looked, but did not see.”

#### Cross References:

See Section 2.5.3 (Attention) - Intersection crashes may also result from inattention or distraction.

#### Key References:

Turner-Fairbank Highway Research Center (2004). Update on Intelligent Vehicles and Intersections. Washington, D.C.: Federal Highway Administration. [Online Newsletter Available at <http://www.tfhrc.gov/pubrds/04jan/08.htm>]

### **2.5.11 Monitoring Other Vehicle Parameters**

#### Introduction:

In this section, other vehicle parameters include engine RPM, acceleration, gear position, throttle position, clutch position, fuel consumption rate and safety belt usage. The reasons of monitoring these parameters can be divided into three categories:

1. Incident reconstruction: in general, vehicle locations, speeds, and accelerations can be used to reconstruct vehicle trajectories during an accident. Since some of these sensors may not work accurately when incidents occur, the redundancy of the sensor information can be very helpful.
2. Prevention of vehicle abuse: two examples are used to illustrate the incentive to monitor vehicle abuse. First, running engines at high RPM frequently can result in abnormal engine wear. The second example is that for vehicles with manual transmission, depressing clutch pedals halfway can cause additional clutch wear or gear damage. As a result, monitoring engine RPM, clutch positions, throttle position, etc, can help prevent abuse by drivers.



3. Fuel economy: one of the concerns from fleet managing teams is the fuel economy. From the aspect of public health, good fuel economy implies less air pollution. Combining throttle positions, gear positions, fuel rate, and engine RPM, one can determine if drivers have good driving habits to “save some gas”. In addition, increased fuel economy has been linked with safer driving, so the contribution to greater fuel economy links to the objectives of OBMS.
4. Safety belt: truck driver safety belt usage can be electronically monitored to give an indication whether the truck is moving *and* the seat belt is not buckled. This is a relatively straightforward monitored parameter that could yield a simple and important change in some drivers’ behavior.

**Candidate Driver Behaviors for Onboard Monitoring**

1. Engine RPM (engine over speed)
2. Appropriate gear selection
3. Use of low gears to save brake when driving on slopes
4. Fully depressing/releasing clutch (for vehicles with manual transmission)
5. Driving time
6. Non-driving time
7. Engine idle time
8. Acceleration
9. Deceleration
10. Fuel Rate/Fuel Economy
11. Safety belt use

Driver Feedback Recommendations:

**Recommended Driver Feedback Designs**

1. Delayed or off-line feedback
2. Note that safety belt use should be fed back both real time and off-line.

Much of the information described in this section is not essential to be displayed in real-time, and those items that are essential already have driver displays.

Additional Discussion:

A listing of COTS systems and the auxiliary vehicle parameters monitored by each is provided below. While these parameters may not always be safety related, fuel economy and vehicle

maintenance translate to direct cost savings for management, making them desirable additions to any onboard monitoring system.

	Mileage	Engine RPM	Acceleration	Gear Position	Throttle Position	Fuel Rate	Clutch Position
XATA	×	×			×	×	×
Delphi	×						
APPlus		×	×	×		×	
Cadec	×	×					
QualCOMM	×	×			×		
DriveCam			×				

Another example is Eaton’s VORAD Information Management System (EVIMS). It analyzes safety trends for drivers and vehicles, benchmarks safety goals for the fleet, and identifies drivers who do meet those goals. The EVIMS does this by comparing individual driver and vehicle performance to fleet averages. Additional features include braking and fuel economy, time on brake, and slow traffic reports.

Cross References:

See Section 2.5.4 (Hard Braking Events).

See Section 2.5.7 (Recording Incidents).

Key References:

APPlus: At the time of this report, information on this company could not be found.

Cadec’s Mobile Information System website: <http://www.cadec.com/>

Delphi's TruckSecure is offered by MobileAria at the following website:

<http://www.mobilearia.com/prodserv/trucksecure.shtml>

DriveCam's website: <http://www.drivecam.com/>

Eaton's EVIMS is marketed and sold through its RoadRanger subsidiary at the following website: <http://www.roadranger.com/>

QualCOMM's SensorTRACS website:

<http://www.qualcomm.com/qwbs/solutions/prodserv/sentracs.shtml>

Transportation Development Centre (June 1998). Incentive Programs for Enhancing Truck Safety and Productivity: A Canadian Perspective. TP 13256E

XATA's website: <http://www.xata.com/>

A successful driver monitoring system should ideally monitor "unsafe" driving behaviors, which might be defined as any behavior that can be shown to be a precursor to increased crash risk. Thus, to understand what behaviors are unsafe, we must first understand what factors "cause" or lead to crashes involving large trucks. As discussed throughout this literature review, this is no easy task, and ultimately, the research to definitively answer this question is still ongoing. However, the delineation of truck crash causal factors is still a key element required to create a ConOps for an onboard driver monitoring system, even if the research reporting the casual factors is still preliminary.

## **2.6 Stakeholder Feedback**

Armed with this information, and working to proceed along the systems engineering Methodology described in Appendix A, we interacted with a stakeholder – a mid-size (100-truck) carrier operating in Los Angeles, California. This carrier had as an operating characteristic in that drivers generally operated from a central dispatch and, although operations were often at

night time, they were at maximum several hundred miles. Drivers rarely slept in their cabs. Moreover, turnover was not high.

A difficulty in interacting with this carrier is that other operational priorities dominated, so it was difficult to schedule time with management and drivers. Hence, the systems engineering approach could not be strictly followed. Specifically, by the time stakeholder feedback could be obtained, hardware procurement and hardware and software integration were well underway. The project team endeavored to ameliorate this poor timing by considering the literature described in previous subsections, and very specifically Section 3.4, and inferred probable stakeholder reaction.

The net result may be positive. At the writing of this final report, it appears that this particular carrier will not likely be part of the envisioned FOT for the very reasons of other operational priorities, and the likely FOT partner will be a different, larger carrier with different corporate and safety culture. Nonetheless, the feedback from “typical” driver in the six-driver groups so-interviewed in this project in an important resource and is reported in two subsections:

- Group Discussions
- Results and Relevancy

### **2.6.1 Group Discussions**

The purpose of this question and answer group discussion was to get driver feedback on an onboard driver monitoring system ConOps. Six drivers from a small- to medium-sized carrier based out of the Los Angeles area participated in a two hour group discussion. The drivers were all full-time employees of the carrier and not owner operators. The carrier employs around 100 drivers at any given time and leases and maintains a relatively new fleet of trucks. The carrier was likely representative of the more safety conscious drivers in the industry, and it was unique in the fact that their trucks were already outfitted with the XATA monitoring system and in the fact that their trucks are speed governed at either 58 or 62 mph (depending on whether the trucks

traveled intrastate or interstate). Likewise, the drivers that participated in the discussion were also representative of the most experienced and safety conscious drivers in the industry.

The drivers were recruited by their management to participate in the discussion group. Most of the drivers participated at the beginning or end of their shift, although one driver volunteered to come in on his day off. Typically, the focus group method requires 8 to 12 participants to achieve the proper group dynamic and any representative or generalizable measure of statistical precision or reliability. For these reasons, this discussion group is not referred to as a focus group. However, since the drivers knew each other, the interactions between members was similar to the group dynamic that is achieved in a focus group, but statistical generalizations, such as 3 out of 6 drivers equating to 50 percent of the truck driving population, should be avoided with this sample.

The following questionnaire was used as a guideline for the two-person interview team.

#### CARRIER Q&A DISCUSSION OUTLINE

##### CPHS Disclaimer

Everything discussed here will remain confidential. Your name and personal information will not be given to anyone except the research team. So please feel free to tell us what you really think. Your participation is strictly voluntary and you may decide to leave the room at any time. Your participation is very important for this study.

- The session will take approximately two hours.
- We would like everyone to be involved in the discussion.
- Everyone's opinions are important!
- We expect different views and opinions. We are not looking for agreement. We are interested in all opinions.
- If you have a cellular telephone, PLEASE TURN IT OFF NOW.

## UCB Introductions

### Denise Allen: Public Policy Analyst

- Background in legislative policy - specializing in public outreach prior to new policy implementation
- Investigates the needs of stakeholders and represents the public interests to policy makers
- Studies human behavior and interactions with the environment

### Christopher Nowakowski: Human Factors Researcher Engineer

- Studies driver behavior to find ways to improve safety and prevent crashes
- Translates the needs of drivers to the designers of advanced safety systems
- Designs interactions between drivers and systems

### Christopher (taking notes)

I would like to go around the table and have you introduce yourself. How about saying your first name, and tell me how long you have been with the company.

### California PATH (Partners for Advanced Transit and Highways)

- Research group that is part of the Intelligent Transportation Studies dept. at UCB
- We act as a research arm between the UC system and its public and private partnerships.

## Past Projects

- Virtual Weigh Station
- Automated Speed Enforcement
- Truck Parking

## OBMS Project Description

- Research for FMCSA (Federal Motor Carrier Safety Administration) and CALTRANS
- FMCSA has sponsored numerous studies on truck safety
  - In general, research shows that truck drivers are extremely safe
  - However, crashes still happen and crashes involving trucks are devastating
  - 450,000 trucks involved in crashes each year lead to 5000 fatalities (According to who? We need a citation here).
- The Focus of this current project is to improve safety through...
  - Onboard Driver Monitoring which provides Feedback and Continuous Improvement
  - Based on the Behavior Based Safety Method

## **We want to...**

1. Identify behaviors which may be precursors to increased crash rates.
2. Determine cost-effective ways to monitor safe and unsafe behaviors.
3. Determine the best way to provide the driver with feedback which rewards safe behavior and discourages unsafe behavior.

- Current Project Status...
- Currently at the conceptual system design stage
- This is only the very first stage of many: conceptualize, prototype, beta test...

- We want your input, both as experts and as the eventual users to help us design a system that will eventually be accepted, useful, and successful
- Both FMCSA and CALTRANS value the input being gathered here today

#### Driver's Opinions of the Current XATA Monitoring System

Now, we'd like to discuss a topic that might be a little more familiar to you. We understand the trucks being used by the carrier are equipped with a monitoring system - the XATA system (used in conjunction with a fuel economy monitoring program)...

- Can you tell me what the system monitors and how it works? (From the driver's point of view)
- How is driver identification done? (Is there a code or electronic key?)
- Preventive maintenance? (What about it?- do you want to know what they think about it or how it works?)
- Can you tell me about the text messaging system? (The system has one. Is it used? If so, for what?)
- How does the fuel economy monitoring and incentive program work?
- What benefits does the system provide to you?
- Did the system change your driving behavior? (Show of hands)
- If so, how? If not, why?
- Do you think a program focused on safety could benefit you? (Show of hands) Please explain what benefits such a program would offer you. If you do not see the benefit, why not?

#### Institutional Issues: Known Positives and Negatives

This list was compiled from other focus groups conducted with truck drivers like yourself.



Positive	Negative
<ul style="list-style-type: none"> <li>• Improved safety</li> <li>• Regular objective assessment of both the good and bad provides opportunity for continuous improvement of driving skills</li> </ul>	<ul style="list-style-type: none"> <li>• Concern that the monitoring parameters are not indicators of safety</li> <li>• Fear of being unfairly penalized for the actions of other drivers? <ul style="list-style-type: none"> <li>- What kind of review process might help with this fear?</li> <li>- Would detailed training on how the system works alleviate fears?</li> </ul> </li> </ul>
<ul style="list-style-type: none"> <li>• Collisions warnings <ul style="list-style-type: none"> <li>- Forward, Side, and Road Departure warnings added as a bonus to monitoring</li> <li>- In the past, drivers thought that this side benefit would help system acceptance</li> </ul> </li> </ul>	<ul style="list-style-type: none"> <li>• Fear of too many bells, whistles, warnings and distractions <ul style="list-style-type: none"> <li>- Does it help to limit audio warnings to only emergency situations</li> <li>- Does it help if most feedback is delayed, given daily, weekly, monthly...</li> </ul> </li> </ul>
<ul style="list-style-type: none"> <li>• Increased efficiency <ul style="list-style-type: none"> <li>- What types of paperwork issues might a system like this be able to automate? (Hours of Service, Others?)</li> </ul> </li> </ul>	<ul style="list-style-type: none"> <li>• Fear of embarrassment or self-consciousness at being monitored <ul style="list-style-type: none"> <li>- Does it help if video is only saved during specific incidents instead of all the time?</li> <li>- What other specific fears?</li> </ul> </li> </ul>
<ul style="list-style-type: none"> <li>• Liability protection <ul style="list-style-type: none"> <li>- When it can be proven you're not at fault?</li> </ul> </li> </ul>	<ul style="list-style-type: none"> <li>• Fear of liability <ul style="list-style-type: none"> <li>- When you might be considered as partially at fault?</li> </ul> </li> </ul>
<ul style="list-style-type: none"> <li>• Incentive programs</li> </ul>	<ul style="list-style-type: none"> <li>• Misuse of the collected data <ul style="list-style-type: none"> <li>- How? What is the fear here?</li> </ul> </li> </ul>

BREAK: 10 Minutes

Unsafe Behaviors (Open Ended)

- What are the biggest safety challenges/obstacles to you as a truck driver?

- What are the common safety problems/pitfalls experienced by novice drivers?
- What driving behaviors should a system monitor to help improve safety? (Please list the top three) (Top 1 to 3)?

Unsafe Behaviors (OBMS Con Ops Feedback)

Expand upon biggest safety concerns for the following topics:

### 1. Speed

- Drivers will probably point out that trucks are speed limited (55/62 mph)
- Where is speeding a problem? Freeways? 2-lane Highways? Suburbs? City?
- Curves? (What do you want to ask them- do they speed around curves?)
- At night? (Does your speed change during certain times of the day? If so, why?)
- How do weather conditions affect safe driving conditions?
- How would you feel about a simple indicator light to alert you that the system thinks you're going too fast?

### 2. Following Distance

- Please explain truck drivers' rules of thumb for following distance?
- Does your following distance change if your trailer is loaded or unloaded?
- Do weather conditions affect your following distances?
- Night? (be specific)
- Are you concerned with cut-ins?
- Are there special cases where short following distance is required?
- How would you feel about a simple indicator light to alert you that the system thinks you're following too close?

### 3. Lane Changes

- Open ended question here...(What are the biggest safety issues with lane changes?)
- Do other drivers around you use their turn signal? Do you use your turn signal? Under what conditions?
- Adjusting mirrors properly? What about it?
- Blind spot check? We need to be very specific

#### 4. Attention/Distraction

- Open ended question here...
- How big of a problem is becoming distracted?
- Common scenarios/situations to look for?
- Lack of attention can lead to hard braking...how often does this happen?
- Lack of attention can also lead to leaving the lane...how often does this happen?

#### 5. Fatigue/Drowsy Driving

- Open ended question here...(How big of a problem in the industry?)
- Is fatigue ever a problem for you? If so, when??
- How do overnight routes work?
- How do 24 hour operations work (shifts)?
- What are the hours of service regulations that apply? (sort of asking for driver interpretation of federal regulations)
- What paperwork do you have to do for hours of service?
- Could an automated system help here? Is so , how- If not, why?(Do they have one already?)

#### 6. Intersections

- Open ended question here...(What are the biggest safety issues with intersections?)

#### 7. Seat Belt Use

- Is seat belt use a problem? Are you asking if wearing it is a problem or if drivers do not wear it?
- Do trucks have the same seat belt warning systems as cars? Can you please explain:

- Is the issue of people just buckling the belt behind them prevalent? What does this mean? Are you asking if people wear the belt properly?
- How would you feel about a random interval snapshot to make sure belt is on? What is a random interval snapshot?

#### 8. Incident Review

- Video saved for review during (hard braking, steering, warning scenarios)
- How might this help you?
- How should such a review process be organized?

That concludes all of the questions we have for you today. Do you have any questions for us?

Thank you so much for taking time out of your busy day to answer our questions. We look forward to our partnership with S&F and working with you again soon.

## **2.6.2 Summary Results and Relevancy**

### *Driver Experience*

At the beginning of the discussion group, the participants were asked to read and sign a consent form and to fill out a short three-page questionnaire on their driving background and opinions on problem areas in the trucking industry. The participants reported between 3 and 25 years of experience with the company (with a mean of 14 years), but all of the drivers had over 19 years of truck driving experience (with a mean of 25 years).

Four out of the six drivers were self-classified as exclusively short-haul, meaning that they leave from and return to the same base of operations each day in under 12 hours. The remaining two drivers were self-classified as primarily medium/long-haul, reporting that about 70 percent of their routes are longer than 12 hours, thus requiring an overnight stay. However, it should be

noted that for this carrier, long-haul routes consisted of a single overnight stay with the driver returning to his home base on the following day.

Road type usage varied wildly between drivers, likely depending on the specific routes driven by the drivers. Several drivers spent most of their time on rural or urban freeways, while others spent a fair amount of time on two-lane highways. However, most drivers agreed that only a very small portion of their routes were composed of suburban arterials or city streets.

### *Perception of Safety Problems in the Trucking Industry*

The questionnaire asked the drivers to rank their level of concern over various safety topics. For most questions, two different answers could be given: one indicating their perception of the problem in regard to truck drivers and the other indicating their perception of the problem in regard to car drivers. For each question, the following four responses were possible:

1. Not Concerned / Not a problem.
2. Somewhat Concerned / It can be a slight problem.
3. Concerned / It is a problem.
4. Very Concerned / It is a serious problem.

On the questions related to speeding, tailgating, aggressive driving, and fatigue (or drowsy driving), the drivers all agreed that they were concerned or very concerned about these issues, fairly equally for both truck and car drivers. However, when asked about hours of service compliance, half of the drivers felt that the issue was not a problem or only a slight problem.

The question on distracted driving elicited interesting responses. Drivers were split between somewhat concerned and very concerned over the issue in regard to truck drivers. However, all of the truck drivers were very concerned over distraction in regard to car drivers. The questions about lack of turn signal use and lack of blind spot checks elicited similar responses patterns, with truck drivers being more concerned with the lack of signal use displayed by car drivers.

Concern over seat belt use was scattered over the responses, and the truck drivers were mostly very concerned with seat belt use among car drivers and not among truck drivers. Interestingly, this was reversed for the question on alcohol and drug use. The participants were mostly very concerned about alcohol and drug use among truck drivers but only concerned when it came to alcohol and drug use among car drivers.

Mechanical failures and adverse weather conditions were generally reported as somewhat concerned or concerned. However, roadway infrastructure issues, such as poor road repair, signage, etc. were mostly reported as either concerned or very concerned.

One driver commented that speeding on highways and especially in construction zones was one of the largest safety problems on the road.

### Discussion Summary

#### *XATA Onboard Monitoring System*

The first discussion topic centered around the participants perceptions of the XATA onboard monitoring system that was already in use by their carrier. The initial questions centered around what the system monitors and how the driver interact with it.

The participants reported that the XATA system served as an electronic log book by monitoring the following parameters:

- Miles traveled
- Speed
- Idle time
- Fuel economy
- Locations
- Breaks
- Traffic, weather, or other incidents causing delay

- Speed governing (58/62 mph depending on whether the truck travels intrastate/interstate)

The system has a key that drivers use to log into and out of the truck, and then return the key to their management to upload the logged data to a central server. Once logged in to a vehicle, the system automatically records everything except traffic, weather, or other incidents causing delay. These events are keyed in by the driver using a text interface. Some frequently used messages, such as traffic delays can be quickly entered via soft menu keys while driving. The drivers pointed out that the system functions only as a log. It cannot be used to communicate with other drivers or with dispatch. Drivers were also unaware of any preventative maintenance functions provided by the system.

The speed governing system beeps at the driver as he approaches the vehicle's maximum allowed speed. Once that speed is reached the engine will not go any faster.

When asked whether or not the drivers liked the system, five of the drivers enthusiastically liked it, while one of the drivers commented that it was only OK. All of the drivers agreed that the XATA system was better than no system at all. The main advantages of the system were described as follows:

- When using the system, the drivers do not have to keep a paper log
- The system backs the drivers up when they are late due to traffic or other incidents
- Drivers do not have to hurry to make up time if they are legitimately delayed
- The system can back up the driver's claim that he wasn't speeding in a crash
- The speed governing cuts down on the number of speeding tickets

Disadvantages of the system included the following:

- A feeling that big brother was watching
- The speed governing system robs engine power
- The system doesn't provide navigation
- The system had no communication (to warn other drivers of traffic jams)

The most controversial part of the system was the speed governing feature. At least 3 of the 6 drivers really liked this feature and perceived it as helping to keep them from getting speeding tickets and helping to keep the company's insurance down. However, one of the drivers commented that speeding, overall, was not as much of a problem for their carrier because the drivers are paid by the hour resulting in less time pressure and less motivation to speed. Another driver commented that California has lower speed limits for trucks (a maximum of 55 mph) than other states, and often there is some latitude given by the California Highway Patrol (CHP), relating a story about being asked by CHP over the radio to speed up even though the driver was at the maximum allowed speed. However, other drivers reacted to that statement by pointing out that the unwritten latitude over speed often can be used against you just as easily resulting in a ticket.

Although none of the drivers were adamantly against the speed governing feature, one commented that the device robbed power from the engine, and another commented that there are times where you need a burst of speed such as before hills and when passing.

#### *General Opinions on Onboard Driver Monitoring Systems*

Next drivers were asked about potential benefits and pitfalls surrounding the concept of driver monitoring. It was presented as a series of perceived advantages and disadvantages to which the drivers could comment or discuss (all of topics had been previously reported on in the OBMS literature).

Overall, all six drivers agreed that onboard driver monitoring and feedback had the potential to increase safety. However, they also agreed that being monitored adds stress and there was worry about how management would use the data. Two of the participants felt that they were good enough drivers that they did not mind a system being on and monitoring them all day long. The other four drivers felt some trepidation towards having a system that monitors them, and might be more comfortable if the system was only recording data during an incident or if the system had an off switch.



Researchers explored driver support and opposition to the use of a hypothetical monitoring system. All of the drivers reported no problems with cameras facing outside the vehicle used to capture the forward traffic scene, but at least four of the participants were clearly against the idea of having a camera pointed inside the vehicle at them. One of the participants was adamantly against placing a camera on the driver, commenting that there was no reason for it and that there was a potential for misuse of any data that it collected.

When asked about adding collision warning devices and real-time feedback to the truck versus the fear of adding too many bells and whistles, the drivers were all in agreement with a preference for real-time warnings and feedback as opposed to offline or delayed feedback. In talking mostly about feedback for “following too close,” three of the drivers felt strongly that the feedback should be visual, while the other three were more undecided. It was mentioned that sometimes visual only feedback is not enough and could be missed, but at the same time, the truck is a loud environment and with the radio turned up, auditory alerts are not always heard either.

When asked about the benefit of liability protection versus fear of liability, the drivers all agreed with both points. The participants pointed out that their current XATA system was already being used exonerate one of their coworkers (and subsequently save his job) who got into a crash and had been accused of speeding.

### *Misuse of Monitoring Data*

One central theme that appeared several times throughout the discussion was the possibility of misuse of the monitoring data (specifically video of the driver) both by management and by lawyers. The concerns centered around the somewhat flexible interpretation of the data. One person may look at the data and interpret it one way, while another may look at the same data and interpret it another way. The drivers felt that this second guessing or backseat driving would only serve to hurt them.

The primary concern over management misuse of the data centered on job security. The drivers expressed concern about what the consequences would be if one of them became fatigued and started to nod off at the wheel or was “distracted” and had an incident. As one driver commented, nobody’s perfect 100 percent of the time. It should be noted that most of these concerns were raised specifically when talking about the use of cameras aimed inside the vehicle at the driver.

### Safety Monitoring Incentive Programs

Only one out of the six participants thought that a safety incentive program would be effective or good for drivers. The sentiments expressed by the other drivers included the following:

- Driving safety was part of their job and not something you give incentives for
- Improved safety was incentive enough
- Driving safety keeps them on the job and with a license and that’s incentive enough
- A tool to help make sure that they do not hurt anyone else on the road was incentive enough

Overall, the drivers agreed that a tool that provided instant, real-time feedback in the cab was preferable to any incentive based program that involved management in the feedback process. Parallels were also made in the discussion between the carrier’s current fuel economy incentive program and the concept of a safety incentive program. The majority of drivers felt that there would always be problems with incentive programs, such as the problem of grading everyone on a curve (comparing data across drivers in a fleet) and not being able to account for differences in the routes (such as traffic). One driver did suggest that any incentive program should look at individual improvements over time, rather than averages across the fleet.

### Monitoring Speed

Based on their experience with the XATA speed monitoring (and governing) system, the participants were generally supportive of a system that monitored speed since they perceived that

their current system kept speeding tickets down. When asked where they thought speeding was the most problem, drivers generally answered with freeways. Speeding in curves was not thought of as a problem for typical or experienced drivers, but might be one way to single out unsafe drivers. One of the participants did comment that a curve over-speed warning system that provided advanced warning of curves might be helpful at night.

The participants generally felt that night driving did not affect their speed selection much because the decrease in traffic congestion allowed the drivers to travel at the speed limit without a problem. Weather was considered a much more important factor. The worst conditions reported by drivers were the combination of fog and rain because of the lack of visibility. Although the drivers felt that they typically slowed down in the rain, especially when their trailer was empty which was considered more dangerous, they were also quick to point out that no one else did.

High winds and wind gusts were considered the most unpredictable weather hazard, especially when the trailer was empty. One driver commented that he might like a system that could provide him with wind direction and wind speed. Another driver commented that moving the tandems forward was helpful. However, there was little agreement on whether drivers should slow down during high winds.

### Following Distance

Overall, the drivers were receptive to the concept of monitoring following distance, but there was little agreement on just how much following distance was appropriate. Answers varied from one to three truck lengths depending on speed and traffic conditions. One driver commented that the more space you leave, the more opportunity there is for cars to cut you off; however, several drivers rebutted this attitude by saying that cars were going to cut them off if they left 10 feet or 100 feet, so they may as well leave enough room to be safe. Other issues brought up by drivers include the following:

- More cut-ins happened at night

- A cut-in followed by braking was considered the most obnoxious and dangerous maneuver
- Vehicles that cut-in do not realize that a stopped truck takes a long time to speed up again
- Vehicles merging (on ramps) do not realize that trucks usually slow a little, and that the merging vehicle should speed up and merge in ahead of them
- Trucks have one speed, i.e., they do not accelerate or decelerate quickly

All of the drivers seemed to like the concept of a following too close warning light, and that such a system would be the most useful in light or medium traffic at faster speeds.

### Lane Changes

The drivers generally agreed that lane changes were often difficult maneuvers since car drivers never want to be behind a truck so they generally will not slow down to let the truck change lanes (even when the truck signals). All six of the participants reported that they always used their turn signals because truck lane changes needed to be planned well in advance (unlike car lane changes which were perceived as more spontaneous). The drivers also agreed that mirror adjustment was critical, always taking place before they left the yard, and the only real blind spot or problem they had was from cars that came from 2 lanes over. Several of the drivers had already driven trucks with blind spot warning system, and all of the drivers were generally receptive to the concept.

### Driver Distraction

Only one of the six participants felt that distracted driving was a major problem among truck drivers. Most participants felt that distracted driving was more of a problem with the drivers of other cars, especially those on cell phones.

### Fatigue and Drowsy Driving

Fatigue and drowsy driving was considered an important topic by the participants and the main points of the discussion are listed below:

- Fatigue is a problem for all drivers, it can just come up on you without much warning
- Getting the proper rest at home is an important way to combat fatigue
- Fatigue is common because biorhythms are not always in synch with the work schedule
- Hours of Service doesn't always correlate to fatigue

The XATA system already electronically recorded hours of service and provided a button for recording driver fatigue in the log; however, the participants reacted favorably to the concept of a fatigue monitoring and feedback system, especially one that provided feedback in the cab.

### Intersections

The only problem reported by drivers at intersections was with the unpredictable actions of cars. The participants described how car drivers were often impatient at stop signs, and cars would often run the stop sign or refuse to yield the right of way to the truck when it was the truck's turn to go.

### Seat Belt Use

Five out of six drivers reported that they always used their seat belts, while the sixth driver reported that he only wore it because enforcement by the CHP was so strict and recanted a story about a driver who was involved in a crash and would have died if he had been wearing his seat belt. The trucks already came equipped with a standard seat belt warning light, but newer trucks have been equipped with orange seat belts to aid CHP with enforcement.

Overall, the drivers were receptive to the concept of seat belt monitoring. Furthermore, three of the participants had a positive reaction to taking random photos to verify seat belt use, while the

other three had a more neutral response. Interestingly, one driver reported that he was currently fighting a ticket given for not wearing his seat belt when he was actually wearing his seat belt, and he commented that a seat belt monitoring system would have helped his case.

### Offline Incident Review

The participants were not very receptive to the concept of post-driving incident review, especially if management were involved. The participants were far more interested in real-time feedback and tools provided in the cab that could help them detect and correct problems with their driving. The general sentiment regarding delayed feedback and incident review centered on the question of what was the consequence of negative feedback or how could the information be used against them. As an example, if the system detected that the driver was fatigued during part of his run, how would it benefit him to know that later and what would be the consequence. Similarly, for the case of a hard braking incident, drivers were concerned over the consequences of the video showing that they glanced away from the road for a second right before the incident.

### Relevancy

This study resulted in the discussion of about 12 major topics regarding onboard driver safety by six experienced drivers working for a small- to medium-sized LA-based carrier. Overall, the participants responded positively to the concept of onboard driver monitoring and feedback for the purpose of improving safety. Most of the other proposed monitoring parameters, speed, following distance, fatigue, lane changes, and seat belt use were well received by drivers. The drivers thought that in-cab systems that could provide real-time feedback for speed, following distance, and fatigue would be useful, and there was no opposition to seat-belt and hours of service monitoring systems.

The drivers were most positive towards in-cab technologies and displays that could be used as a tool to help keep them driving safely. When presented with various scenarios and feedback options, the drivers always preferred options that could provide them with in-cab, real-time feedback, as opposed to off-line or delayed feedback. The drivers made a good point in that

delayed or offline feedback may come too late for them to really understand the problem and modify their driving behavior.

Although all of the drivers preferred in-cab feedback, there was little agreement on how to best provide that feedback. It was not surprising that the drivers had differing opinions over the question of visual versus auditory feedback since the generally accepted answer to that question is most often “it depends.” Interestingly, the discussion did suggest that truck drivers might be more tolerant of auditory alerts than car drivers tend to be, as the participants made no mention of complaints over the auditory speed alert provided by their current XATA system. It is noted that to be effective, an auditory alert should be loud enough to be heard over the ambient noise.

Based on the discussions, the parts of the onboard driver monitoring ConOps that are most likely to encounter resistance from the drivers include the use of cameras aimed at the driver and the use of off-line or delayed feedback. The primary concern over both of these issues was the potential for misuse of the collected data, a widely cited institutional concern in regard to onboard driver monitoring systems. The participants described two ways in which the data could be misused. First, the drivers made an excellent point about the potential for alternate interpretations of the collected data and video (i.e., backseat driving or armchair quarterbacking). Although the engineers who designed the system might have one intention for the system and interpretation of the data, both management and lawyers (in the event of a crash) might each make their own interpretation.

The point made by drivers on the issue of alternative interpretations is not entirely without merit. Most of the monitoring parameters that have been proposed in the onboard driver monitoring ConOps are, at most, related to increased crash risk. However, crashes are very rare and complex events, and their causes are often the subject of much debate. As an example, distraction has been cited as cause of as few as 30 percent and as high as 80 percent of crashes. Much of that variation comes from the fact that the definition of just what constitutes distraction or inattention has not been standardized. Take for instance, the following example. A truck is following a car, and the car signals and merges into a turn lane. Having no vehicle in front of him, the truck driver glances away from the road briefly, but returns to find that the car was

merging back into the trucks path (without checking his blind spot). Depending on how you interpret the described incident, distraction may or may not be cited as the cause.

Even going a step further, most would agree that eyes-off-the-road time is a good indicator of distraction, but there is little agreement on a specific maximum eyes-off-the-road time. Some might argue 1.5 seconds while others argue 2 seconds, and the results are always subject to interpretation. Furthermore, glancing away from the road for more than 1.5 seconds likely occurs very frequently without any ill effects, and tasks, such as reading a map to get directions, involve distraction from the road, but still amount to a significant part of normal driving.

The second point the participants made regarding the potential for misuse of monitoring data was centered on the potential consequences to the drivers when offline or delayed feedback is provided. The drivers generally asked questions such as, “What would be the consequences of the feedback report showing that a driver was fatigued during part or all of their trip?” These concerns came from both the justified notion that nobody can be perfect 100 percent of the time, and a fear that poor reports or several incidents could or would be used against them as cause for termination. Although the intention of the driver monitoring and feedback program is to provide opportunity for continuous feedback and improvement of driving skills, the concerns over this sort of alternate and misuse of the program are valid.

Along these same lines, the most resistance encountered with any of the proposed monitoring parameters came from the proposed use of a driver video camera. The drivers had no issue with video taken of the road scene or a camera that simply took still snapshots of the driver to determine whether or not he was wearing seatbelt. However, cameras that took video during incidents were viewed providing too much potential for misuse.

Although both of the points made by the participants (the potential for alternative interpretation and the potential for misuse of the data) held merit, recent research does corroborate the validity and usefulness offline or delayed feedback and incident review. While a single incident or near crash might not indicate an increase crash risk, the recent 100-car study found that patterns of



frequent incidents and near misses were indeed indicative of increased crash risk (Klauer, et al., 2006).

### **References (Section 2.6)**

Klauer, S., Dingus, T., Neale, V., Sudweeks, J., and Ramsey, D. (2006). *The Impact of Driver Inattention on Near-Crash/Crash Risk: An Analysis Using the 100-Car Naturalistic Driving Study Data* (DOT HS 810 594). Washington, D.C.: National Highway Traffic Safety Administration (NHTSA).

### 3 PROTOTYPE SYSTEM

The OBMS prototype system was designed in accordance to the systems engineering process described in Appendix A and in particular along the Vee Diagram methodology. This entailed development and use of a ConOps-derived set of requirements (given also in Appendix A) which address the eleven feature set recommendations discussed in Section 2.0 and listed in Section 2.5. Because of their central role in specific OBMS prototype discussed in this section, these eleven monitoring task recommendations bear repeating:

1. Monitoring Vehicle Speed
2. Monitoring Following Distance
3. Monitoring Attention
4. Monitoring Hard Braking Incidents
5. Monitoring Lane Position
6. Monitoring Lane Changes
7. Monitoring and Recording Incidents
8. Monitoring Fatigue
9. Monitoring Hours of Service
10. Monitoring Behaviors at Intersections (which again is beyond current technology; however this task monitoring category warrants discussion for the long term when it may become practicable)
11. Monitoring other vehicle parameters (e.g., safety belt use, lane change turn signal use, lane change blind spot check, proper mirror adjustment, fuel economy, engine overspeed, acceleration, deceleration, gear selection on grades)

This section concentrates on the implementation of the sensor and data recording requirements. Software and algorithms for event detection implemented in the prototype are described in Section 4, and prototype driver feedback mechanisms are described in Section 5. Specifics of this system are provided in the ensuing subsections as follows:

- Overview of prototype implementation
- Hardware layout and operating principles

- Software building blocks and interfaces
- Sensor and data acquisition performance

### 3.1 Overview of OBMS Prototype Implementation

A detailed block diagram of the OBMS prototype is shown in Figure 3-1. The On-Board Processor/Core Unit is implemented in the OBMS prototype as a PC-104 Plus stack, containing the cards shown in Table 3-1. This computer records the output from a variety of sensors onto its hard drive and drives a display for driver feedback, as well as implementing on-board real-time monitoring algorithms.

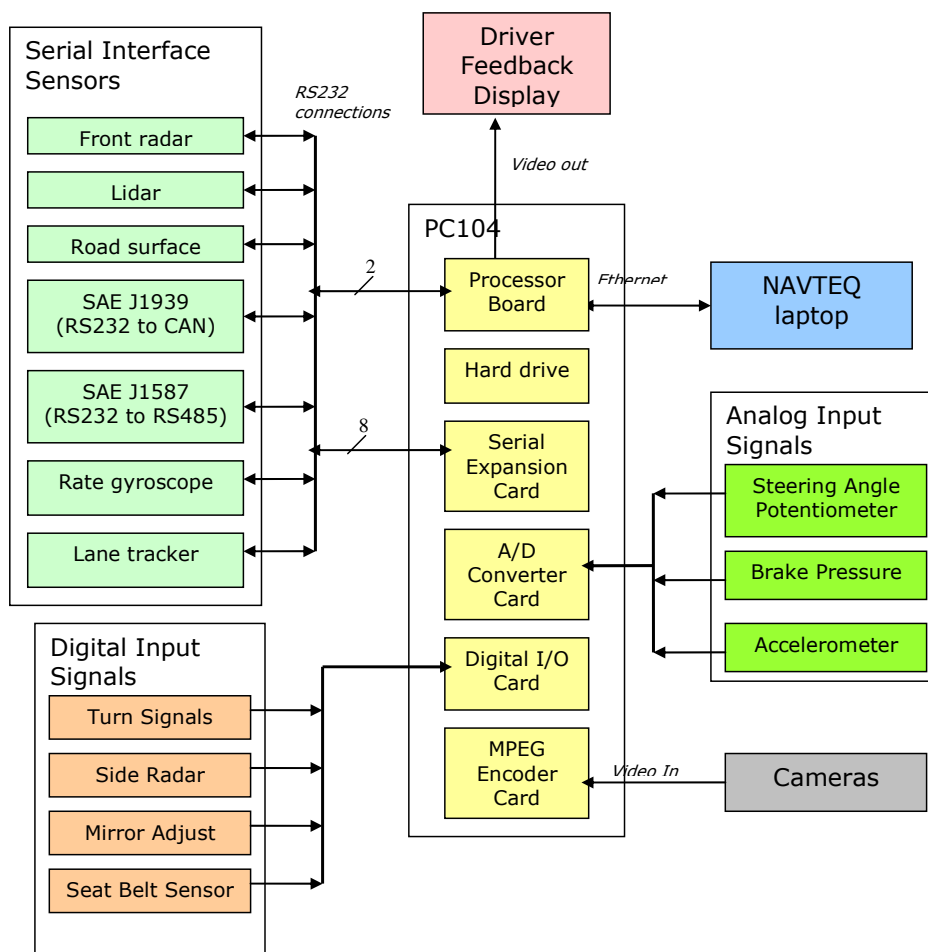

**Figure 3-1. Block diagram of OBMS prototype PC104 and sensor interfaces**

The environmental sensors and inputs to the computer include a frontal radar, frontal lidar, side radar, lane tracker, road surface state detection system, frontal camera, and GPS. Vehicle sensors include steering wheel angle, gyroscope, brake pressure, and an accelerometer. Vehicle parameters such as vehicle speed and cruise control are acquired from the J1939 and J1587 vehicle data buses, and direct connections to truck electrical signals such as turn signal activation are also connected as digital inputs. In addition, the two video cameras capture the forward road scene and passenger compartment of the truck. Hardware identification and brief descriptions of these sensors are given in Table 3-2.

**Table 3-1. Component cards of OBMS prototype PC104 On-Board Processor**

Component	Qty	Make/Model #	Function
Processor Board	1	Advanced Digital Logic Pentium M 1.4 GHz	Includes two serial ports and Ethernet connection as well as graphics display card.
Hard drive	1	Desktop Hard Disk Drive	Software installation and data recording
Serial Port Expansion Card	1	Connect Tech Xtreme/104	Adds serial ports to the PC
Analog Digital Converter Card	1	Diamond Systems Corp DMM-32X-AT	Inputs analog signals to the PC
Digital Input Output Card	1	Diamond Systems Corp DMM-32X-AT	Inputs digital signals to the PC
MPEG Encoder	1	Advanced Micro Peripherals MPEG44000-4	Converts video to MPEG-4 format files

**Table 3-2. Sensor Systems and Data Sources of OBMS Prototype**

Component	Qty	Make/Model #	Function	Card or bus
Forward radar sensor	1	Eaton-Vorad EVT-300	Range, rate and angle to nearby obstacles	RS232
Side radar sensor	1	Eaton-Vorad EVT-300	Presence of obstacles at side	RS232
Lidar	1	Nippon-Denso Prototype Lidar	Range, rate and angle to nearby obstacles	RS232
Lane Tracker	1	Assistware SafeTRAC	Measure vehicle position in the lane	RS232
Road Surface Sensor	1	Innovative Dynamics Inc RoadSight Mobile	Detect presence of road contamination	RS232
SAE J1939 CAN bus	1	B&B Electronics 1939STB	Converts SAE J1939 data bus to RS-232	RS232
SAE J1587 CAN bus	1	B&B Electronics 232SAER	Converts SAE J1587 data bus to RS-232	RS232
Rate gyroscope	1	Crossbow VG400	Measures vehicle rate of pitch, yaw, and roll and pitch angle	RS232
Steering Angle Potentiometer	1	Ametek PSS-40A	Measure steering wheel angle	A/D card
Accelerometer	1	Summit 23203a Bi-axial Accelerometer	Record vehicle acceleration	A/D card
Brake Pressure	1	AST4000	Measure applied brake pressure	A/D card
Video cameras	2	Visiontech1/3" color CCD Minivision camera	Video cameras	Video card
NAVTEQ System	1	NAVTEQ ADASRP	GPS location, road curvature, speed limits	Ethernet

While Figure 3-1 and Tables 43-1 and 4-2 highlight the OBMS prototype hardware installation, Tables 4-3 and 4-4 show the relationship of these hardware components to the requirements in Appendix A. Table 4-3 shows the correspondence between the COTS sensor requirements of Appendix A and the OBMS prototype components. Table 3-4 shows the sensors used as a data source for the driving parameters that are to be monitored on a continuous basis.

**Table 3-3. Sensor Requirements and Corresponding OBMS Prototype Components**

Sensor	ID	OBMS Prototype Component	Message Length (bytes)	Update Period (ms)
1	Accelerometer	Summit 23203a Bi-axial Accelerometer	N/A	37.5
2	Driver ID reader	Eaton Vorad EVT 300 driver ID message	3 - 13	10000
3	Electronic On-Board Recorder (EOBR) /Hours of Service (HOS)	Calculated from driver ID and engine speed in prototype. (Expected to be via COTS system in subsequent versions.)	N/A	10000
4	Front radar / warning system	Eaton Vorad EVT 300	4 - 60	65.536
5	GIS roadway map	NAVTEQ ADASRP	variable	1000
6	GPS receiver	NAVTEQ ADASRP	24	1000
7	Lane position monitor	Assistware SafeTRAC	39	500
8	Outward video camera	Visiontech 1/3" color CCD Minivision	N/A	N/A
9	Road surface conditions sensor	Innovative Dynamics Inc RoadSight Mobile	variable	1000
10	Rollover sensor	Calculated from Gyro and Navteq data	N/A	50
11	Side radar	Eaton Vorad EVT300	N/A	37.5
12	Steering angle sensor	AmetekPSS-40A	N/A	37.5
13	Thermometer	None		
14	Throttle angle sensor	Equivalent information from J1939 EEC2	28	50
	Wheel	From J1939 CCVS	40	100

15	speedometer			
16	Wiper usage monitor	None	N/A	
17	Brake pressure monitor	AST4000	N/A	37.5
18	Mirror adjustment monitor	Custom add-on signal	N/A	37.5
19	Turn signal monitor	Custom add-on signal	N/A	37.5
20	Seatbelt usage monitor	Custom add-on signal	N/A	37.5
21	Driver camera	Visiontech 1/3" color CCD Minivision	N/A	N/A

**Table 3-4. Driving Parameter Requirements and OBMS Prototype Data Source**

Parameter	ID	OBMS prototype data source
P1	Driver identification	Eaton Vorad EVT300 driver ID message
P2	Following distance	Eaton Vorad EVT300, Nippon Denso prototype lidar
P3	Hours of service	Not directly available from vehicle bus, but is derived in prototype. (Expect to use one of several available COTS systems in subsequent versions.)
P4	Lane position	Assistware SafeTRAC
P5	Road surface conditions	Innovative Dynamics Inc RoadSight Mobile
P6	Roadway curvature	NAVTEQ ADASRP
P7	Roadway scenery	Video
P8	Seat belt usage	Custom digital input
P9	Vehicle location	NAVTEQ ADASRP
P11	Speed	J1939 CCVS message
P12	Brake pressure	AST4000
P13	Steering angle	AmetekPSS-40A
P14	Occupancy of side	Eaton Vorad EVT300

	lane	
P15	Turn signal use	Custom digital input signal



### 3.2 Hardware Layout and Operating Principles

In developing the OBMS prototype, a driving factor in the hardware selection was to consider elements that could, with perhaps minimal adaptation or substitution be used in a subsequent larger-scale FOT. The Freightliner tractor used for the OBMS prototype is pictured in Figure 3-2. The data recording computer and all associated hardware are mounted in the sleeper portion of the cab.



**Figure 3-2. Freightliner Tractor Platform Used for OBMS Prototype System**

The sensor data is recorded using an industrial PC-104 Plus computer using ISA/PCI architecture and a 1.4 gigahertz Pentium M PC running the Linux 2.6 operating system installed from the Kubuntu 5.10 distribution. It uses a serial port expansion card, an analog to digital and digital to analog converter card, and a MPEG encoder card all mounted internally to read the sensors and various inputs. All the analog voltage signals are anti-alias filtered before being input to the analog to digital converter card. All the sensors attached to the serial expansion board communicate with the RS232 protocol. This computer records the output from the sensors onto an internal 100 gigabyte hard disk drive. A picture of the installed computer system is shown in Figure 3-3.

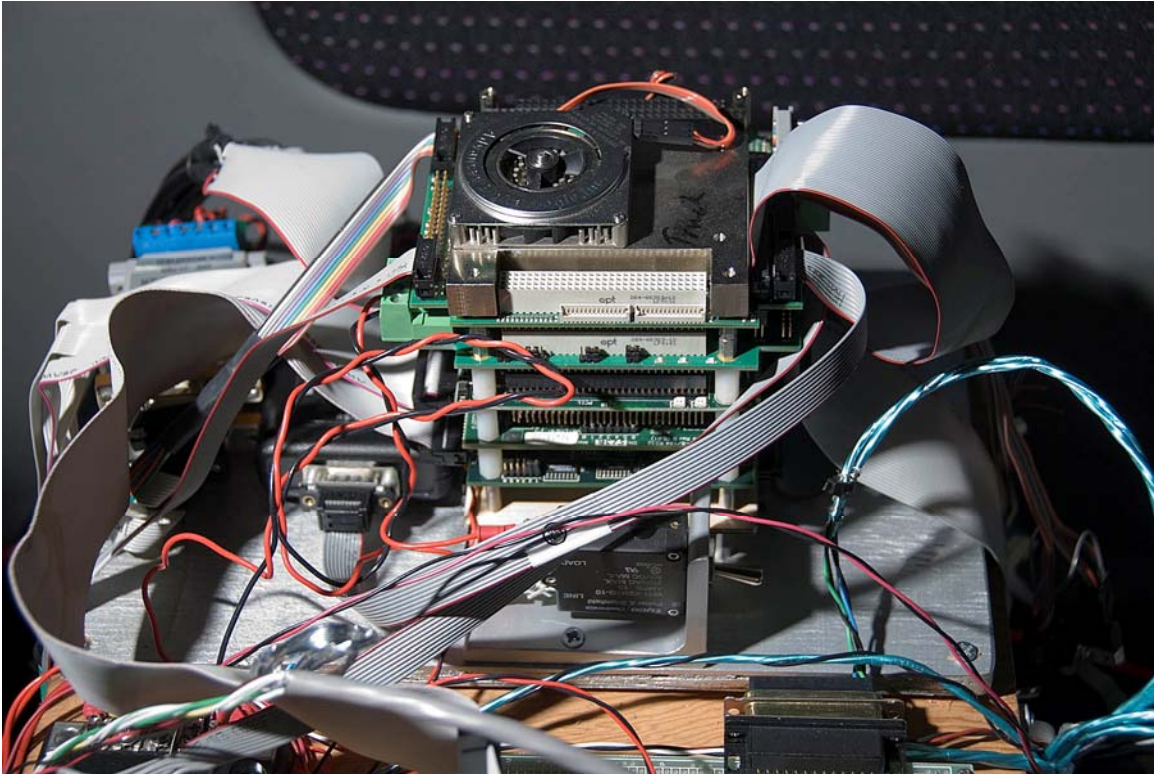

**Figure 3-3. Computer and Associated Electronics**

The sensors selected to capture the environment around the truck include the commercially available Eaton-VORAD EVT-300 mono-pulse millimeter wave radar. This radar unit, on the front of the vehicle, measures the distance and azimuth angle for multiple targets up to a distance of 100 meters in front of the vehicle. This unit is mounted in the center of the front grill and was installed by Freightliner as an option when the truck was built. Included in the EVT-300 system is a simpler radar unit mounted on the right side of the vehicle that only registers the presence or absence of an obstacle in the adjacent lanes, and does not provide distance or azimuth information about the obstacle. This sensor is mounted on a side fairing of the truck behind the passenger door. Also included in the system are the driver display units mounted in the view of the driver for the front and side radars as well as a system CPU.

Also mounted on the vehicle is a prototype Nippon-Denso mechanically scanning infra-red lidar. This unit also measures the distance and azimuth angle for multiple targets up to a distance of 100 meters in front of the vehicle. This unit is also mounted in the center of the front grill. The radar and lidar are shown in Figure 3-4.



**Figure 3-4. Radar and Lidar Sensors**

Another sensor fitted to the truck, the Assistware SafeTrac, is a video based lane detection system (lane tracker). This system finds the lane boundaries of the lane the truck is traveling in and measures the position of the truck within the lane. The camera for the lane tracker is mounted near the windshield and the control unit is mounted on top of the instrument panel in the view of the driver.

An Innovative Dynamics Inc RoadSight Mobile off the shelf road surface state detection system was also installed on the truck. This system detects whether the road is dry, wet, snowy, or icy. The system bounces two infra-red lasers off the road surface and detects the spectral differences of the road surface and possible road surface contaminants. The sensor head for this unit is mounted on the passenger side of the cab above the passenger door. The control electronics are mounted in the cab above the passenger seat. This sensor is pictured in Figure 3-5.

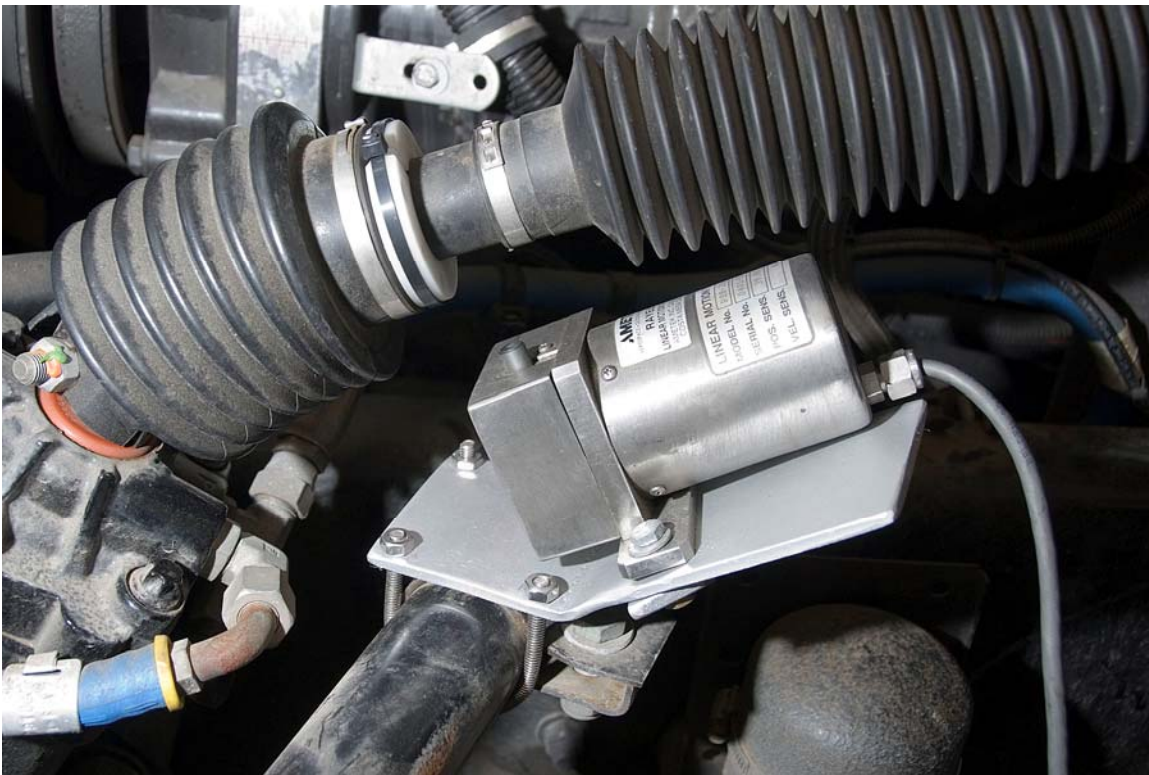

**Figure 3-5. Road Surface Detection System Sensor (viewed from bottom)**

The vehicle is also equipped with a NAVTEQ Advanced Driver Assistance Systems Research Platform (ADASRP) GPS. This system is composed of GPS processor, gyro, and vehicle speed and backing status inputs mounted in an enclosure called a NAVTEQ box. The NAVTEQ box sends data to a laptop running the ADASRP software. This software does map matching using the GPS and the gyro and vehicle transmission inputs to do dead reckoning during GPS outages. The ADASRP sends vehicle location information as well as information about the road ahead and the local speed limit to the PC-104 computer. These units are mounted in the rear of the cab and the GPS antenna is mounted on top of the cab.

Other sensors record the driver inputs to the truck. The hand wheel angle is measured with a string potentiometer. This string potentiometer is mounted in the engine compartment as shown in Figure 3-6. The string is attached to the steering column. As the steering column rotates, the

string wraps or unwraps around the column, depending on which direction the steering wheel is turned.



**Figure 3-6. Steering Wheel Angle Sensor (String Potentiometer)**

A gyroscope and analog accelerometer are mounted in a weather proof enclosure on a frame rail near the 5<sup>th</sup> wheel hitch plate, depicted in Figure 3-7. The gyro is a Crossbow VG400 tri-axial fiber optic rate gyro with tri-axial accelerometers. The analog accelerometer is a Summit Instruments 23203B bi-axial MEMS accelerometer with a 1g range.



**Figure 3-7. Rate Gyro and Accelerometer Enclosure (opened)**

The brake pressure applied by the driver is measured with a pressure transducer. The American Sensor Technology AST4000 pressure transducer is plumbed into the brake system on the left front brake actuator as shown in Figure 3-8.

The engine SAE J1939 and SAE J1587 data buses are also monitored on the truck. Data such as throttle position, wheel speed, cruise control status are recorded on these data buses.

Turn signal and mirror adjustment usage are determined by connecting four computer digital inputs to the respective power relays on the truck.



**Figure 3-8. Brake Pressure Transducer**

Also mounted on the truck are two CCD “board” cameras. These cameras are mounted behind the windshield in a small enclosure. One camera looks at the forward road scene and the other camera looks at the driver. The video streams from these cameras are connected to an MPEG encoder card in the computer. The computer then writes the MPEG files to the hard disk drive. Also mounted in the camera enclosure is the camera for the lane tracker. The enclosure is shown in Figure 3-9.

The system is powered from the vehicle battery and charging system. All cabling and most sensors are installed behind trim panels and fascias. Thus the Truck looks like a normal truck, not a research vehicle. The only obviously visible component is the camera housing for the cameras.



**Figure 3-9. Camera Enclosure**

### **3.3 Software Building Blocks and Interfaces**

In keeping with the system requirement for modular software design, the OBMS prototype software makes heavy use of reusable software components developed at PATH during previous Caltrans projects as well as drivers supplied by the manufacturers for COTS systems. Without the availability of this preexisting software it would have been impossible to implement a functioning OBMS prototype with the limited time and resources available. Preexisting PATH software components included processes to interpret the Eaton Vorad EVT 300, Nippon Denso Prototype Lidar, SafeTRAC Lane Tracker, and Navteq ADASRP message formats as well as the SAE J1939 and SAEJ1587 in-vehicle data bus formats. Integration of these processes with the new drivers was facilitated by the use of a publish/subscribe in-memory database for interprocess communication. This publish subscribe applications programming interface (API) has been used at PATH for a number of years on the QNX4 and QNX6 operating systems and was ported to Linux last year for the use of this and other projects.



Software has been written to read and record all the data from the sensors described in Section 3.2, and make it available to applications that identify significant driver behavior and events and issue feedback, as described in Sections 5 and 6. In the following subsections we will give more detail about :

- Software architecture, including the publish subscribe database
- Software for serial interface devices(EVT300, Nippon Denso Lidar, J1939, J1587, Crossbow Gyro, Roadsight, SafeTRAC)
- Software for communicating with NAVTEQ ADASRP over Ethernet
- DMM32 device driver and analog and digital input issues
- Video recording software

### **3.3.1 Software Architecture**

The OBMS real-time software may be roughly divided into three types of processes that communicate using the publish/subscribe API through a memory-resident data server:

- device resource managers that interface directly with the hardware and supply sensor inputs to the data server
- analysis programs that extract filtered event and driver behavior information from the raw sensor inputs and write this processed information to the data server
- notification and recording programs that may use any information available from the data server to provide feedback through the graphical user interface, and that save selected data for later analysis and feedback.

The interaction of these three types of clients with the publish/subscribe data server is graphically illustrated in Figure 3-10.

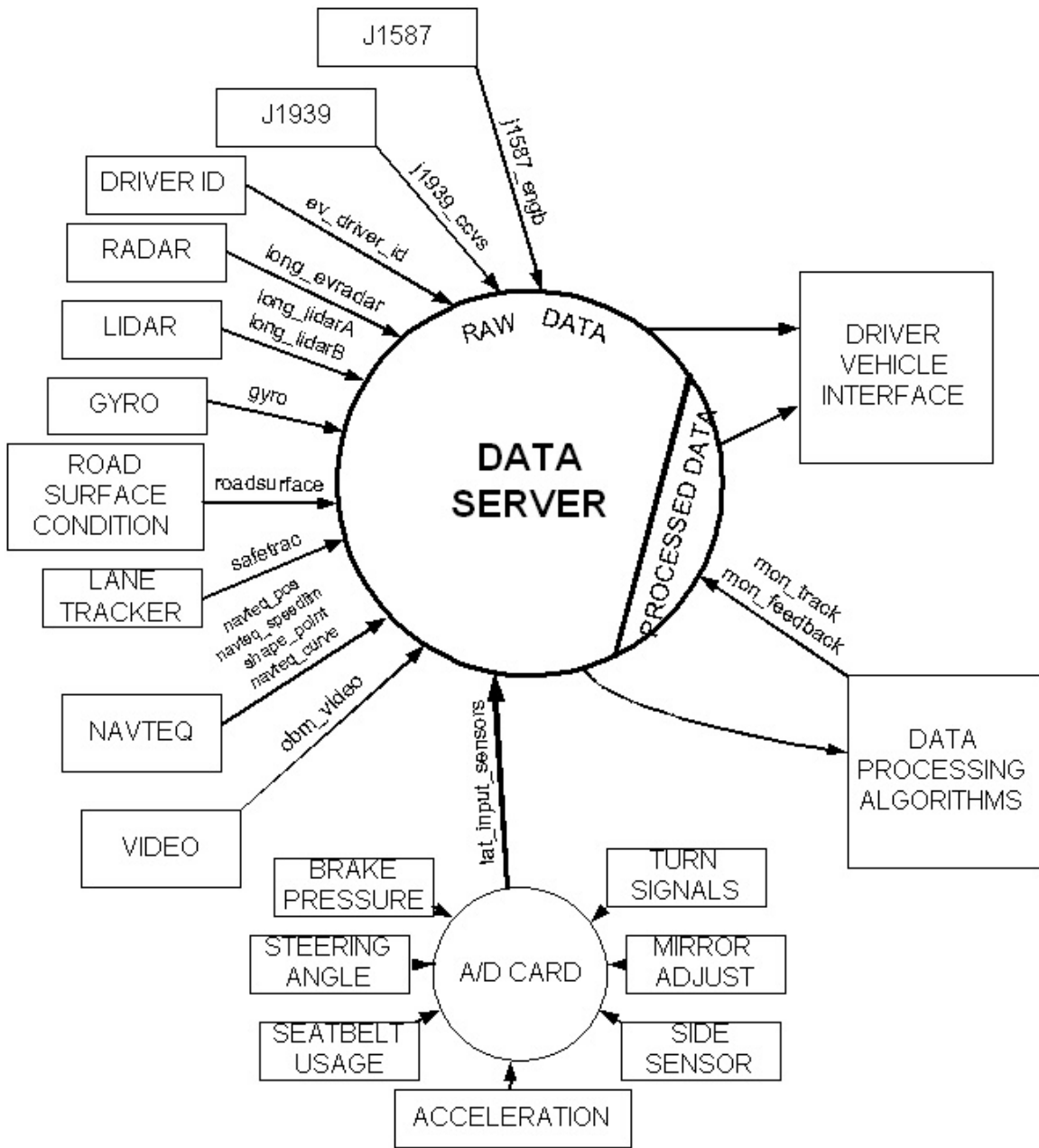

**Figure 3-10. Publish and Subscribe Data Clients in OBMS Prototype**

Device clients are on the left of the dataflow diagram; the arrows showing the direction of the data are labeled with the data structure type carrying that data. The data processing module on the right processes the raw data and writes the processed data to the data server. The DVI reads and displays both raw and processed data.

All three types of processes operate as clients of the publish/subscribe data server, which allows client processes to create, read and write variables of structured types, as well as to subscribe to a notification service indicating when a particular variable was updated. These notifications are called triggers and can be seen as messages that are sent to the client process from the database.

The publish/subscribe data server framework is modular, generic, and inherently asynchronous (producers and consumers need not know about each other and can run at different rates). It has been used successfully in many different PATH applications, including car platooning as part of the Automated Highway Systems project, and car longitudinal and lateral control, truck, bus, snowplow and automated ship applications. The data server provides asynchronous inter-process communication in the sense that a process can write a database variable without worrying who the potential consumers might be, or at what rate they read the data.

In summary, the publish/subscribe API contains primitives to:

- Register/log out of the database
- Create/destroy a database variable of a specified number of bytes
- Read a variable
- Write a variable
- Set/unset triggers for variables

These requests are atomic, which means that the database will completely serve a request before it proceeds with the next request (that is, the database serializes the requests). Atomicity ensures database integrity, which means that the value read by a client is not modified during the reading process, and that the most recent value of a variable is always made available.

The publish/subscribe API can be easily ported as an easy-to-use layer for user level processes on top of lower level interprocess communication primitives. On QNX the publish/subscribe API was based on kernel-level message passing. On Linux it uses Posix message queues to provide data sharing while maintaining data integrity and avoiding race conditions.

### 3.3.2 Software for Serial Interface Devices

Database clients for the various serial devices were constructed similarly: each logs into the database, creates its own database variables, and opens a connection to a serial port. The client then enters an infinite loop: it reads serial data as it comes into the port, parses the message into usable data, and writes the data to the database. Clients differ in the message format, message content, and may poll the device (infrequently) in addition to receiving a data stream.

The following is a synopsis of the serial port clients:

**Eaton-Vorad radar** – client parses three different messages from EVT – 300. They are:

- Driver Display Unit (DDU) Display Update Message: proximity warnings, message length 4 bytes, update period 250 ms or 65.536 ms for 1 second on change
- Front End Target Report Message: range and relative velocity, message length 4 – 60 bytes, depending on number of targets acquired, update period 65.536 ms.
- DDU Driver ID Data Message: driver ID, message length 3 – 13 bytes, depending on length of user-selected ID, polled data, update period 10 seconds.

This client was ported from QNX 6 to Kubuntu 5.10.

**Nippon Denso Lidar** – the lidar message is 146 bytes long, containing a 3-byte header (0xFF 0xFF 0xFD) and a checksum in the last byte. The payload is data for up to eight targets. Each target has the following fields (all are relative to the subject vehicle): lateral position, vertical position, distance, lane rate, vehicle rate, target status, lateral velocity, width, height, depth, and relative acceleration. This client was ported from QNX 6 to Kubuntu 5.10.

**J1939/J1587** – the CANbus messages important to this project are:

J1939

- CCVS (Cruise Control Vehicle Speed), containing the wheel based vehicle speed, message length 40 bytes, update period 100 ms

- EEC2 (Electronic Engine Controller #2), containing accelerator pedal position, message length 28 bytes, update period 50 ms.

J1587

- 183 (Fuel rate), update period 200 ms
- 190 (Engine speed), update period 100 ms

**Crossbow Gyro** – the message from this device is 22 bytes long, containing ten 2-byte measurements of angle, angular rate, acceleration, temperature, and time. It contains a header byte (0xFF), and a checksum byte at the end. The update rate is 75 Hz.

**Roadsight** – uses two infrared lasers of different wavelengths to detect road condition (dry, wet, snowy, icy), message is variable-length ASCII, update rate ~1 Hz. This device outputs an ASCII string, terminated by a newline, containing eight values: short wavelength voltage, long wavelength voltage, temperature (we do not have the temperature option installed, so this value is undefined), ratio of the voltages, displayed condition code number (0 – 15), measured condition code number (0 – 15), displayed condition mnemonic (3 characters), measured condition mnemonic (3 characters).

**SafeTRAC Lane tracker** – the message from this device is 39 bytes long, update rate ~2 Hz. The message header is two bytes long (0x5A 0xA5), and a checksum is at the end. The message contains the fields: lateral offset, lateral velocity, road curvature, lane width, left and right boundary types, offset confidence, curvature confidence, driver alertness index, and alert system status.

### 3.3.3 Software for Communicating with NAVTEQ ADASRP over Ethernet

The NAVTEQ COTS software resides on a laptop and communicates to the PC104 via Ethernet. It transmits three message types of interest to this project:

0x403 - latitude, longitude and distance traveled since the last transmission

0x501 - current speed limit

0x502 - projected road curvature information ahead of the vehicle

The client is started up with two arguments: the IP address of the NAVTEQ laptop, and the port that the laptop will be using to communicate. Once the connection is established, the client waits for a data stream over the socket pair. When data starts coming in, the client searches for the header [0x64, 0x19, 0x11, 0x29] and then begins reading data. This client was ported from QNX 6 to Kubuntu 5.10. Changes to the original code were:

<u>Task</u>	<u>QNX</u>		<u>Linux</u>
login to the data server:	getnid() (QNX)	→	gethostbyname() (Linux)
transport:	COMM_QNX_XPORT	→	COMM_PSX_XPORT
call to localtime():	_localtime	→	localtime_r

In order for the NAVTEQ COTS has to work, the vehicle must begin moving for it to begin outputting data over the Ethernet port. Moreover, it only works for Windows OS, which may cause it to occasionally crash.

### **3.3.4 DMM32 Device Driver and Analog and Digital Input Issues**

The Diamond Systems DMM32 provides 32 single-ended 16-bit resolution analog-to-digital inputs, 24 digital I/O lines, and four 12-bit resolution digital-to-analog outputs. The update period is 37.5 ms.

Analog inputs:

- Brake pressure transducer: AST4000. Used in determining hard braking events.

- Steering angle potentiometer: AmeTek PSS-40A. Used in determining hard steering events.
- Accelerometer: the Summit 23203a puts out two analog signals, namely x and y accelerations. Its calibration sheet gives the sensitivity of each voltage along its own axis and along the other axis. That is, there is “crosstalk” between the two sensors. Thus the “true” acceleration for each axis is calculated from a linear equation using the coefficients given in the calibration sheet. Voltage offsets are zeroed by measuring the voltages when the vehicle is stopped, and subtracting them from subsequent measurements.

Digital inputs:

These devices are actually read as analog signals and their values compared to their respective thresholds. A “1” means “TRUE” and a “0” means FALSE

- Turn signals
- Mirror adjustments
- Radar side sensor
- Seatbelt use

### **3.3.5 Video Recording Software**

The OBMS video recording software stores video clips (from two separate sources, one for the driver and the other for the front-view) before and after a given event signal. The event signal is sent through the database. The video clip contains the video of at least two minutes prior to the event. Example snapshots from the video event recorder are shown in Figure(s) 3-11 a. and b.



**a. Forward Road Scene: Single Car**



**b. Forward Road Scene: Multiple Cars**

**Figure 3-11 a and b. Example Forward Scenes from Video Recorder**

The system requires four video inputs (A,B,C,D) where A and B are from one video source (which requires a video splitter) and C and D from the other.

The video recording software receives two signals, sync (or timer) and event, through the system database. The sync signal comes with sync information, which is used to define the filename. The filename convention follows the usual PATH sensor recording filename convention, vmmddsss-n.mpg where:

mm = month (2 digits)

dd = day of the month (2 digits)



sss = sequence number (3 digits)

n = video input (1 or 2)

For example, v1203004-1.mpg or v0123051-2.mpg.

Given a sync signal, the software starts recording two video clips (one for A or B and the other for C or D). The recording is alternative. For one sync signal, the video from A and C are recorded and for the next signal, the video from B and D are recorded. The recording ends with the 2nd sync signal from when it started. Therefore, the two consecutive video clips will overlap with each other. For example, the timeline for the video clips taken on 12/3 is as follows:

A :	v1203000-1.mpg	v1203002-1.mpg	...		
B :	v1203001-1.mpg	v1203003-1.mpg	...		
C :	v1203000-2.mpg	v1203002-2.mpg	...		
D :	v1203001-2.mpg	v1203003-2.mpg	...		
Sync:	^	^	^	^	...
Evnt:				^	

Normally, the sync signal will be sent in every two minutes, with the same sync applied to other engineering data such as lidar. Therefore the length of the usual video clips is be four minutes. In order to save disk space, not all the video clips will be stored to save the disk space; rather, only the video clips around the event signal will be stored to hard drive.

At all times, two overlapping copies of video clips are recorded. For example, when an event is triggered, both v1203002-1.mpg and v1203003-1.mpg are being recorded (for camera #1). The previous one (v1203002-1.mpg) is always 2 minutes longer than the new one (v1203003-1.mpg). When an event signal is triggered, the longer video clips (v1203002-1.mpg) are stored in the hard drive. As a result, whenever an event occurs, the stored video clip contains at least two minutes of video prior to the event. The recording finishes at the next timer signal. The engineering software therefore sends the next timer signal two minutes after the event signal.

## 4 OBMS FUNCTIONS

### 4.1 Truck Following/Stopping Distance under Variable Conditions

#### 4.1.1 Introduction and Motivation

Per Section 2, monitoring vehicle stopping distance as truck following distance in mixed truck in fleet management may be one way to mitigate truck-involved vehicle crashes. The vehicle stopping distance is determined by several factors: current speed, braking system retardation force, tire slip, and road grade. For truck on-board monitoring and real-time feedback to the driver, it is necessary to know at anytime the appropriate stopping distance. Data available in literature only shows partially the stopping distance information on flat, dry and concrete road surface conditions. In practice, trucks are driven under variable environments. In the OBMS project, practical implementation issues in addressing real-world, heterogeneous environment and a multiple-aspect algorithm were implemented.

Truck OBM longitudinal (following and stopping) algorithm development includes the following aspects: (i) truck stopping distance under variable weather and road geometric conditions; (ii) front multiple target tracking and relative distance and speed estimation; (iii) *recommended following distance* under variable conditions such as weather and road situation; (iv) *recommended speed* under similar variable conditions; and (v) the human factor. The combination of all five aspects is a unique feature of this algorithm, resolved in the OBMS project with an underlying multiple-aspect algorithm described in this section.

Points (i), (iii) and (iv) are closely related to truck dynamics, road geometry and weather. Truck dynamics itself is very complicated if coupled with weather and road geometry. This OBMS study considers the problem with a pragmatic, limited basis, aimed at prototype development.

Front multiple-target tracking using vehicle on-board remote sensors is key for threat assessment of potential collisions between vehicles. For OBMS, a tracking algorithm was developed for three potential front targets: target on the left, middle and right lanes. Other targets beyond the three lane widths are ignored.

In the OBMS work, the road curvature effect on target tracking is not considered due to the aforementioned pragmatic, limited prototype development scope of the project. This means that it is implicitly assumed that the freeway is straight ahead. There were many ways for assessing the threat of potential collision between vehicles. Basically, it is determined by relative distance, speed and acceleration. Relative distance and speed could be determined by remote sensors of target tracking is well-built. However, relative acceleration would be very difficult to estimate in real-time. Thus target tracking is usually accompanied by relative distance and speed estimation for the targets tracked.

Using vehicle *stopping distance* as the criterion for truck *following distance* may be one way to mitigate truck-involved vehicle crashes. Vehicle stopping distance is determined by several factors: current speed, braking system retardation force, tire slip, and road grade. For truck on-board monitoring and real-time feedback to the driver, it is necessary to know at anytime the appropriate stopping distance. All the previous data available in literature only proved partially the stopping distance information on flat, dry and concrete road surface conditions.

The *recommended following distance* is less conservative than the truck stopping distance if the front target is moving. Such a distance is determined by threat assessment for vehicle front collision and avoidance, which is determined mathematically by relative speed, relative acceleration and reaction time from a kinematics viewpoint. However, the relative acceleration is difficult to measure with current technology. Thus the worst case scenario of relative accelerations, i.e. the potential deceleration capability and front target and maximum deceleration capability of the truck, are selected as constants. Although the implementation of the recommended following distance does not incorporate variable environmental conditions such as road grade and tire slip, it is important to take them into consideration in any on-road, operational implementation. The analysis method for any future implementation will be similar to that for considering vehicle stopping distance under variable conditions.

Speed is another important factor for truck safety. High speed (as discussed in Section 3.0) not only causes threats to other vehicles, but also causes instability of truck itself, such as rollover. It is thus necessary to provide a *recommended speed*. Several factors would affect the recommended speed: (a) speed limit of the road; (b) speed determined by rollover stability

threshold; (c) traffic speed in adjacent lanes; (d) road geometry such as curvature and grade; (e) weather conditions (tire slip); (f) a combination of all. Due to limited time, resources and pragmatism, this effort considers the first four factors.

Rollover for large commercial truck with tractor and trailer combination is a very complicated problem which involves vehicle dynamics, road geometry and weather (tire slip). This project, based on previous study and our experience in vehicle dynamics, has preliminarily implemented a *Three-step Progressive Rollover Warning* (feedback): (1) On approaching curve: prediction using vehicle lateral acceleration based on road curvature data and GPS position from the NAVTEQ system and vehicle speed; (2) On the curve: prediction using vehicle lateral acceleration and truck speed based on real-time

Truck OBM algorithm development includes the following aspects: (i) truck stopping distance under variable weather and road geometric conditions; (ii) front multiple target tracking and relative distance and speed estimation; (iii) *recommended following distance* under variable conditions such as weather and road situation; (iv) *recommended speed* under similar variable conditions; and (v) human factor.

Points (i), (iii) and (iv) are closely related to truck dynamics, road geometry and weather. Truck dynamics on flat road is itself very complicated. If it is coupled with weather and road geometry, the situation is extremely difficult to handle. This project only preliminarily considers the problem under some limited situations due to limited resources. For example, recommended following distance is based on relative speed and distance without road geometry and road surface condition involved. Recommended speed is determined by several factors: road speed limit, threatening of roll-over caused by speed, and traffic speed in nearby lanes. Roll stability warning only considers road curvature without weather and road surface condition involved.

#### **4.1.2 Vehicle Stopping Distances under Different Conditions**

This section is to discuss the effect of other physical factors on vehicle stopping distance. Here the physical factor is to distinguish those from driver behavior. The most obvious physical

factors include: vehicle load, vehicle speed road surface condition, road grade and the combination of them all. The following notations are used for discussion in this section:

$M$  – vehicle mass

$D_0$  - required stopping distance on flat road

$D_\theta$  - required stopping distance on graded road with grade  $\theta$

$v_0$  – vehicle initial speed (longitudinal) just before braking

$\theta$  – road grade,  $\theta > 0$  means ascending;  $\theta < 0$  means descending

$g$  - acceleration of Gravity

$\mu$  - friction coefficient

$F_{trac}$  - total traction force of all the wheels

$N_f$  - normal force of all the wheels

$T_b$  - total braking torque on wheels from braking system

$T_b^{(a)}$  - braking torque on wheels contributed by air brake

$T_b^{(e)}$  - braking torque on wheels contributed by engine brake

$T_b^{(t)}$  - braking torque on wheels contributed by transmission retarder

$d_w$  - wheel effective radius

The unit system used is *k-s-m*.

## Vehicle Load

It seems obvious that vehicle load would affect the vehicle stopping distance a lot. However, the following analysis indicates that this is not the case.

Vehicle kinetic energy stored at the time instant of braking is  $\frac{1}{2}Mv_0^2$ . To bring the vehicle to completely stopped, the work done by the traction force of the braking system (pneumatic brake, engine brake, and transmission retarder) should be equal to this number. This is the first of the following equations.

$$D_{stop} F_{trac} = \frac{1}{2} M v_0^2$$

$$F_{trac} = \mu N_f$$

$$T_b = (T_b^{(a)} + T_b^{(e)} + T_b^{(t)})$$

$$F_{trac} d_w \leq T_b$$

The second equation just says that the traction force is proportional to the normal force from the vehicle to the ground. The third equation says that the braking torque is from three components: pneumatic brake, engine brake, and transmission retarder. The last inequality is an assumption that the effective braking torque the traction force could provide cannot exceed the braking torque provided by the braking system. In other words, the braking system has adequate retardation force compared the traction between the wheels and road surface. This assumption is reasonable for healthy braking system satisfying the FMVSS (Ashley, et al).

Now since  $F_{trac} = \mu N_f = \mu Mg$ , the second equation above becomes

$$D_{stop} \mu Mg = \frac{M v_0^2}{2}$$

Or simply,  $D_{stop} \mu g = \frac{v_0^2}{2}$ , which suggests that as long as the braking system has adequate retardation force on wheels, vehicle stopping distance is independent of vehicle load. If this assumption is not true, then for the same vehicle, more load would require longer stopping distance.

What is the number in practice? Table 4-1 includes the stopping distances, compiled by the Frederick County Highway Safety Task Force, which roughly gives a relationship with vehicle mass on flat road.

**Table 4-1 . Average Total Stopping Distance vs. Weight**

Type of vehicle	Passenger Car	Tractor-Trailer, cab only	Tractor - Trailer, empty	Tractor-Trailer, loaded, with cool brakes	Tractor-Trailer, loaded, with hot brakes
Stop distance in [m]	58.8	74.1	75.9	78.03	131.06

The main point here is that the stopping distances for cab only, empty tractor-trailer combination and fully loaded truck do not have much difference. However, the heavier loading would require slightly longer stopping distance.

It is noted that the last column is the case when the air brake is hot, for example, after long period of braking. In this case, the retardation force of the brake could significantly reduce and the required stopping distance would be longer. However, properly combine engine brake and transmission retarder to reduce the use of air brake for continuously braking for a long period of time could reduce brake temperature and compensate for this. Thus, the hot brake case will not be discussed separately.

## Weather (Road Surface) Conditions

Here, the weather condition affect the vehicle stopping distance through the road surface condition, or the weather affect the tire slip  $\mu$ . Tire slip is very complicated, which depends on several factors: material, stiffness and trade types and depth. This means that different tires with the same normal force would generate different traction force. To practically simplify the discussion, it is assumed that the trade and material meet the standard and their differences between tires are ignored.

Most previous work considers truck and other vehicle stopping distance on a dry flat road. When weather factors are taken into consideration, the suggested truck stopping distance may not be applied to the corresponding driving situation. This is due to the fact that rubber tire vehicles have different friction coefficients when the road surface condition changes. The note suggests some weather related vehicle stopping distance which could be used as references for Truck on Board Monitoring.

The tire slip coefficient  $\mu$  depends on the tire characteristics (material, trade, stiffness), road surface conditions (Nishira, et al)

**Assumption 1:** Vehicle will remain in road and continue in a longitudinal motion without lateral slippery.

**Assumption 2:** road surface is either concrete or asphalt. On the other hand, vehicle stopping distance  $D_{stop}$  represented in maximum deceleration  $d_{max}$  (under idea situation, for example dry asphalt or concrete on flat road) and initial speed  $v_0$  is:

$$D_{stop} = \frac{v_0^2}{2d_{max}}$$

**Assumption 3:** Vehicle braking system has adequate braking torque.



This assumption removed the possibility that stopping distance is affected by braking torque. This assumption is reasonable since modern truck as a combined braking system composed of engine brake (Jake brake), transmission retarder and pneumatic wheel brake.

The maximum deceleration  $d_{max}$  can be considered proportional to the longitudinal traction  $d_{max} = \beta F_r$  where  $\beta$  is a constant for given vehicle, but may vary from vehicle to vehicle. Now we have:

$$D_{stop} = \frac{v_0^2}{2d_{max}} = \frac{v_0^2}{2\beta F_r} = \frac{v_0^2}{2\beta\mu N_f}$$

For a given vehicle with the same load,  $\beta$  and  $N_f$  will be the same. The weather dependent road surface only affect the slip coefficient  $\mu$ . For the same initial speed  $v_0$ , the stopping distances  $D_{stop}^{(i)}, (i=1,2)$ , of the same vehicle in weather condition 1 and 2 have the following relationship:

$$\frac{D_{stop}^{(1)}}{D_{stop}^{(2)}} = \frac{\frac{v_0^2}{2\beta\mu_1 N_f}}{\frac{v_0^2}{2\beta\mu_2 N_f}} = \frac{\mu_2}{\mu_1}$$

where  $\frac{\mu_2}{\mu_1}$  may be called relative (to idea road situation) tire slip coefficient.

Table 4-2 provides values of  $\mu$  in different road surface conditions:

**Table 4-2. Tire Slip Coefficients in Weather (on flat asphalt/concrete road)**

<b>Weather condition</b>	Dry	Wet	Heavy Rain	Icy
<b>Tire slip coefficient</b>	0.8	0.53	0.45	0.2

The research by Ashley studies brake performance in detail for several makes on a straight road in different scenarios, including some with brake failures, and the result is close that in shown in Table 4-1.

### **Road Grade Conditions**

Road grade is another factor affecting vehicle stopping distance. This is particularly true for heavy vehicles. In general, suppose we are considering the problem in the same road surface condition. Intuitively, when a vehicle going up a hill, required stopping distance is shorter than on a flat road. While when a vehicle going down a hill, the required stopping distance will be longer than that on a flat road. Quantitatively, this is considered as follows. The calculation is irrespective vehicle mass and the types of vehicles. Thus the results can be used for any vehicle.

Suppose the road surface condition is the same for flat and graded road. Then friction coefficients are the same for flat road and for graded road. For flat road, stopping distance can be calculated as follows:

$$\mu \cdot M \cdot g \cdot D_0 = \frac{1}{2} M v_0^2 \quad (4.1)$$

Here it is implicitly assumed that the braking system of the vehicle can provide enough braking torque (retardation force), which means that the total stopping distance only depends on the friction force between the tires and the road. This also implicitly assumes that the traction of the tire only depend on the road surface, or equivalently, the tire dynamics would not change during braking process.

For vehicle of the same mass and the same initial speed but on a graded road with grade  $\theta$  would be:

$$\mu \cdot M \cdot g \cdot D_{\theta} \cdot \cos \theta = \frac{1}{2} M v_0^2 + M \cdot g \cdot D_{\theta} \cdot \sin \theta . \quad (4.2)$$

The left hand side is the work done by braking force; The first term in the right hand side is the kinetic energy the vehicle has at the time instant of starting braking. The second term in the right hand side is the potential energy of the vehicle caused by the road grade.

Solving the equation (4.1) for  $D_{\theta}$  and dividing both sides of equations (4.1) and (4.2) leads to:

$$D_{\theta} = \frac{D_0}{\cos \theta - \sin \theta}$$

This formula can be used to calculate the stopping distance for a vehicle on graded road. If  $D_0$  happens to be the stopping distance of the vehicle on flat road but in different weather,  $D_{\theta}$  will be the stopping distance on a graded road in corresponding weather condition.

### **Vehicle Current Speed**

Researchers from the James Madison University gives a relationship between speed and stopping distances in Table 4-3. This table can be interpolated with polynomials: 2<sup>nd</sup> -4<sup>th</sup> order polynomials with Least Square fitting, shown in Table 5-4. The 2<sup>nd</sup> order achieves reasonable accuracy.

Table 4-4 contains the result of experiments made with motor vehicles, unloaded except for the driver, equipped with all-wheel brakes, in good condition, on dry, hard, approximately level stretches of highway free from loose material. It has also accounted for the average driver response time delay.

**Table 4-3. Vehicle Speed and Stopping Distances**

Miles per Hour	Meter Per Second	Automobile Brakes (in Meter)	Truck Brakes (Brakes on All Wheels) (In Meter)	Average Driver Reaction Time (3/4 seconds) (In Meter)	Automobiles Total Stopping Distance (In Meter)	Truck Total Stopping Distance (In Meter)
10.0	4.4714	1.5240	2.1336	3.3528	4.8768	5.4864
15.0	6.7056	3.6576	5.1816	4.8768	8.5344	10.0584
20.0	8.9428	6.4008	9.1440	6.7056	13.1064	15.8496
25.0	11.1618	9.7536	14.3256	8.2296	17.9832	22.5552
30.0	13.4112	14.3256	20.4216	10.0584	24.3840	30.4800
35.0	15.6362	19.2024	28.0416	11.5824	30.7848	39.6240
40.0	17.8918	24.9936	36.5760	13.4112	38.4048	49.9872
45.0	20.1168	31.6992	46.3296	15.2400	46.9392	61.5696
50.0	22.3418	39.0144	56.9976	16.7640	55.7784	73.7616
55.0	24.5974	47.2440	69.1896	18.5928	65.8368	87.7824
60.0	26.8224	56.3880	82.2960	20.1168	76.5048	102.4128
65.0	29.0474	66.1416	96.3168	21.6408	87.7824	117.9576
70.0	31.2725	76.8096	111.8616	23.4696	100.2792	135.3312
75.0	33.4975	88.0872	128.6256	24.9936	113.0808	153.6192
80.0	35.7226	99.9744	146.3040	26.8224	126.7968	173.1264
90.0	40.2336	129.5400	185.0136	30.1752	159.7152	215.1888
100.0	44.6837	156.6672	228.6000	33.2232	189.8904	261.8232

**Table 4-4. Analytical Relationship Between Stopping Distance and Vehicle Speed**

Vehicle Types	Average Stopping distance [m] versus speed [m/s]	Average Total Stopping distance [m] versus speed [m/s]
Automobile	$D_0 = -0.002593 \cdot v_0 + 0.030575 \cdot v_0^2$	$D_0 = 0.101900 \cdot v_0 + 0.030526 \cdot v_0^2$
Truck	$D_0 = -0.000437 \cdot v_0 + 0.044166 \cdot v_0^2$	$D_0 = 0.104055 \cdot v_0 + 0.044117 \cdot v_0^2$

### Combined Factors

If the above three factors are combine together, which can significantly affect the vehicle stopping distance, the following relationship is reached:

$$D_{\theta}^{\mu_2} = \frac{D_0^{\mu_1}}{\cos \theta - \sin \theta} \frac{\mu_2}{\mu_1}$$

$$\mu_1 = 0.8(\text{asphalt})$$

Where the stopping distance in nominal road condition  $D_0^{\mu_1} = D_0$  is given in Table 4-4.

#### 4.1.3 Front Target Tracking

Between target tracking and relative distance/speed estimation, target tracking is the main challenge in the implementation. Preliminary work in this respect has been investigated extensively by Lu and others at California PATH if the remote sensor is fixed on the ground. However, the OBMS prototype uses Doppler radar (EVT-300) and DENSO Lidar (laser radar) as on-board remote sensor for front multiple-target tracking and relative distance and speed estimation. Radar is mainly used for relative distance and speed estimation.

Front multiple-target tracking is the key for threat assessment for collision between vehicles. Multiple target tracking using vehicle on-board remote sensors such as radar is more challenging due to the following factors:

1. The detection or recognition capability of each sensor is very limited physically: Doppler radar is good for relative distance measurement but accurate for distance and lateral position (or azimuth) measurement. Laser radar (lidar) is good for distance measurement but speed estimation is not as good as the Doppler radar. Besides, the sensitive signal reflecting materials of the two radar types (micro-wave and laser) are different. For example, lidar likes the rear light of the front vehicle, while Doppler radar may see the rear end of the truck easier. Due to those factors, about 25% ~ 30% of the target-time has been missed by either of them. Algorithm has been developed to fuse the two signals to combine their advantages to achieve more reliable multiple target tracking.
2. False target: Due to the subject vehicle moving, front targets situation relative to the vehicle are complicated – any objects in the sight of view of the sensor would be taken as a potential target by Doppler radar and lidar. Besides, is it unreasonable to simply drop static objects since there may be a vehicle stopped ahead in front of the truck lane.
3. Subject vehicle vibration: The subject vehicle vibration causes the radar/lidar beams moving around and thus large disturbances to the sensors in the measurement of distance, angle and speed of the targets. Besides, significant vibration may cause missing front target.
4. From target vehicle lane changing behavior: Front target vehicle lane changing will cause confusion of the internal tracking of radar and lidar by changing the tracking ID. Besides, lateral position or azimuth estimation is more difficult.
5. The curve of the road ahead: Unless the road curvature is well predicted ahead, road curve ahead causes front target lateral shift. For example, road curve ahead to the left may cause target in the right lane to be missed and the target in the middle lane to be mistaken as the target in the left lane.

To fully solve those problems with all the factors addressed would require extensive research with multiple sensor fusion techniques development in the future.

This project has developed tracking algorithm for three potential front targets: target on the left, middle and right lanes. Other targets beyond the three lane widths are ignored. In this phase of the project, road curve affect on target tracking is not considered yet. This means that it is implicitly assumed that the freeway is straight ahead.

## Front Multiple Target Tracking Using Radar and Lidar

A standard Eaton Vorad set (EVT-300) provides information for up to seven targets, with an update interval of 75ms. Information includes target ID, speed, distance, and azimuth. This means that the radar set has an internal tracking algorithm besides filtering.

To achieve this, it is necessary to use prediction in the tracking algorithm in addition to target association due to target missing. Other tracking and association methods are referred to by Bar-Shlom and Mobus. These methods use a Kalman filter approach for multi-target tracking in developing Adaptive Cruise Control. Distance-based tracking algorithms are used for Lidar (Laser Radar) for developing a Frontal Collision Warning System (Wang, et al). Methods used here are for simplicity, reliability and effectiveness. Particularly, the characteristics of the Doppler radar are fully utilized.

The main problem for vehicle following using radar is to detect targets in the front although there may be multiple vehicles in each lane. The characteristic of Eaton Vorad is that it is speed based measurement, which will be used in radar target tracking and association. This means that the criteria for building tracks corresponding to vehicles, threshold should be set with respect to target speed. This can be called a speed-based which is different from those of distance based measurement like Laser radar or video camera. The following terminologies and notations are used:

*Track* – A track corresponds to an expected target which may be composed of several time series of data assigned. Each time series of data corresponds to one parameter or state (speed, longitudinal distance, lateral distance) of the target. A tracking algorithm is a rule to redistribute the data from the seven channels of the data set. Suppose the number of lanes is  $N$ , the maximum number of target to be tracked is also  $N$ .

## Filtering

For the built tracks, it is necessary to smooth the data series. For radar distance measurement, low-pass digital filters are used for smoothing the measurement. Particularly, the following filter is used:

$$\bar{x}(t) = \lambda \cdot x(t) + (1 - \lambda) \cdot \bar{x}(t - 1)$$
$$0 < \lambda < 1$$

where  $\bar{x}(t)$  is the estimate of current time step,  $x(t)$  is the measurement of current time step, and  $\bar{x}(t - 1)$  is the estimate of previous time step.

## Prediction

A simple prediction method is used to predict the vehicle speed and distance based on acceleration for the case when radar misses the target. Let  $\Delta t$  be the time step. A simple kinematic model is used for the prediction:

$$x(t) = x(t - 1) + v(t - 1) \cdot \Delta t$$
$$v(t) = v(t - 1) + a(t - 1) \cdot \Delta t$$

At each time step, acceleration  $a(t)$  is calculated and saved in the buffer. If there is no target loss  $a(t) = [\bar{v}(t) - \bar{v}(t - 1)] / \Delta t$ . If there is a temporary target loss,

$$a(t - 1) = [\bar{v}(t - 1) - \bar{v}(t - 2)] / \Delta t$$
$$\bar{v}(t) = \bar{v}(t - 1) + a(t - 1) \cdot \Delta t$$
$$\bar{x}(t) = \bar{x}(t - 1) + \bar{v}(t - 1) \cdot \Delta t$$

are used as estimates.



## Fusion of Radar and Lidar Signals

Because the characteristics of lidar and radar and their detection capabilities are different, it is necessary to fuse the tracks built from those two sensors to produce a reliable front target tracking. Some parts are complementary. The advantage for data fusion is to use their strength and avoid their weakness. To achieve this the following fusion logic is used: If radar has no detection while lidar has detection, using lidar data; If radar has reasonable detection while lidar does not, then use radar data; Otherwise, a Kalman filtering approach to assign appropriate weight to those two streams of data.

A static Kalman filter is used to fuse those two for relative distance measures in normal cases (Chui). The purpose for data fusion is to achieve a more reliable and accurate measure by means of sensor redundancy: (a) Using two distance estimates to compensate for each other's measurement to reduce target loss, (b) Using Kalman filtering properties to achieve an optimal estimation by assuming that the two measures from radar and lidar sets are simultaneous and are independent (Chiu, Maybeck), and (c) All signals – relative distance, speed and lateral position – are fused.

Let  $y_L(n)$ ,  $y_R(n)$  denote lidar and radar measurement in the longitudinal direction at time step  $n$ . Let  $y_{LR}(n)$  denote the fused longitudinal distance of the target at time step  $n$ . Let  $\bar{y}(n)$  denote the prediction variable. Then the Kalman filter for data fusion can be written as the following “predictor-corrector” form:

$$\begin{aligned}\bar{y}(n) &= \frac{\sigma_{y_L}^2}{\sigma_{y_L}^2 + \sigma_{y_R}^2} y_R(n) \\ y_{LR}(n) &= \bar{y}(n) + K(n) \left( y_L(n) - \bar{y}(n) \right) \\ K(n) &= \frac{\sigma_{y_R}^2}{\sigma_{y_L}^2 + \sigma_{y_R}^2}\end{aligned}$$

where  $K(n)$  is generally recognized as the gain of the corrector, and  $\sigma_{y_L}^2$  and  $\sigma_{y_R}^2$  are the variance of lidar estimate and radar longitudinal distance measurements, which are obtained by comparison of the estimated value from measurement and those broadcasted by the test vehicle.

The fusion of relative speed and lateral position measurement are the same and are not repeated here.

#### 4.1.4 Recommended Following Distance

The recommended following distance is preliminarily determined based on *time headway* under normal environmental conditions. The recommended following distance is described by:

$$S_{recomm} = \left( \frac{v_L^2}{2a_L} \right) - \left( \frac{v_F^2}{2a_F} \right) + T_R \cdot v_F + B$$

$$v_L = \dot{r} + v_F$$

where

$v_L$  – leading (target) vehicle speed; obtained from radar/lidar tracking

$a_L$  – leading (target) vehicle acceleration;  $v_F$  – following (object) truck speed

$a_F$  – following (object) acceleration

$r, \dot{r}$  – relative range and range rate of the truck with respect to the front target vehicle, obtained from radar/lidar tracking

$T_R$  – reaction time

$B$  – minimum safe following distance

Since the target vehicle acceleration is difficult to measure/estimate based on remote sensor,  $a_L = -4.0[m/s^2]$  as the maximum deceleration of the front vehicle, and  $a_F = -2.0[m/s^2]$  as the maximum braking capability of the fully loaded truck, which corresponds to the worst-case scenario  $B = 10m$  is considered as the minimum distance relative to the front vehicle. This consideration is based on the research on threat assessment for collision warning system at Mazda, illustrated in Figure 4-1.

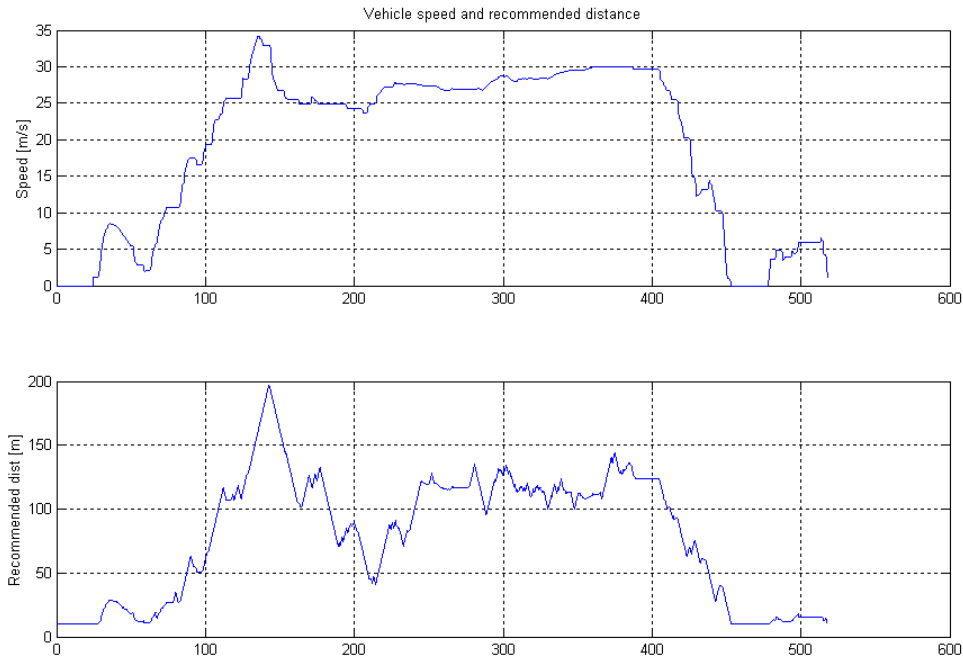

**Figure 4-1. Truck Speed vs. Recommended Distance**

#### 4.1.5 Recommended Speed

The recommended speed is mainly determined by three factors: (a) speed limit of the road based on geographical situation of the road such as curvature, grade and elevation; (b) simplified rollover threat assessment; and (c) traffic speed: the average speed of vehicles in adjacent lanes. The *recommended speed* is the minima of the three. The speed limit of the road is obtained from the NAVTEQ system in real-time which is eventually determined by highway design standards. Under normal weather condition, the limit is usually the safe speed. However, the limit speed needs to be reduced adaptively under the following conditions:

- Tire slip reduced due to weather such as rain, snow and ice
- Curvature and superelevation of the road

As will be discussed later, lateral acceleration could be used as threat assessment index for rollover warning. Based on this consideration, it is possible to generate speed threshold for

curved road is the curvature can be predicted from other sensors such as NAVTEQ system. Using on the critical lateral acceleration for Freightliner fully loaded trucks:

$$a_N(\text{critical}) = 0.225g$$

One can estimate recommended speed as:

$$\rho(t)a_N(t) = v(t)^2$$
$$v_{roll} = \sqrt{\rho(t)a_N(t)}$$

In the implementation, the recommended speed would be  $v_{recom} = \min\{v_{limit}, v_{roll}, v_{traffic}\}$

where  $v_{limit}$  is from the speed limit of the road;  $v_{roll}$  is the critical speed for rollover threshold as above; and  $v_{traffic}$  is the traffic speed based on tracking of front target of left and/or right lanes.

#### **4.1.6 Preliminary Consideration of Rollover Warning**

This subsection preliminarily considers rollover warning based on vehicle dynamics from an implementation viewpoint instead of extensive theoretical analysis.

Truck (tractor and trailer combination) may have high center of gravity (CG) or may lose traction on curved road when vehicle speed is above some threshold. Those factors may lead to rollover of commercial trucks. Truck rollover not only causes damage to the truck itself and hurt the driver, but also causes more devastating consequences to other vehicles on the highway if the traffic density is high. The situation is even worse if hazardous materials are loaded on the truck.

As discussed by Baker, truck rollover is likely to cause the following consequences:

- (a) Property damage
- (b) Human life
- (c) User costs - delays
- (d) Environmental liability

- (e) Loss of traffic mobility/efficiency
- (f) Capital infrastructure costs

It is important to have an effective device to warn the driver for any potential rollover. From vehicle dynamics viewpoint, truck rollover is the result of losing stability. Truck dynamics can be divided into tractor and trailer coupled at the king pin. The trailer dynamics can be considered as coupled sprung mass and unsprung mass as shown in Figure 4-2.

### **Previous Rollover Studies**

Brievik considered factors which cause truck rollover. By means of a powerful simulation package provided by DaimlerChrysler, a numerical sensitivity analysis with respect to vehicle parameters was performed. It was found that the stability of the system is highly dependent of the loading condition. Based on simulation results and literature studies, it was determined that the event of wheel liftoff is very significant with respect to rollover. Wheel lift off will cause a significant difference in wheel angular speed of the two wheels on the same axle due to the differential mechanism. This work thus suggests using the wheel angular speed difference  $\Delta_{\omega}$  as another measure of rollover.

$$\Delta_{\omega} = \frac{|\omega_l - \omega_r|}{\min(\omega_l, \omega_r)}$$

Once the  $\Delta_{\omega}$  is above certain threshold, a warning should be issued to the driver. The paper claimed that it can provide 0.5s warning ahead.

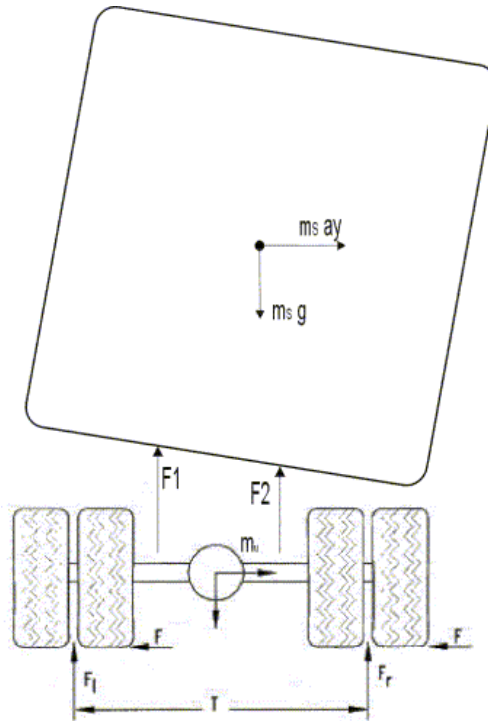

**Figure 4-2. Vehicle Sprung Mass Model**

Kamnik considered the maneuver-induced vehicle rollover which is primarily attributed to the dynamic roll behavior of the trucks, while the contributions from the tripping mechanism are absent. This work claimed that kind of rollover might occur during low-speed cornering and braking or high-speed evasive directional maneuvers. This work used analytical truck dynamics in the roll plane and evaluated by the numerical simulator of the Freightliner tractor/trailer combination. It appeared that the vehicle roll response, encompassing the lateral acceleration and the sprung and unsprung mass roll angles, was directly related to the rollover coefficient and was nearly in phase with it.

The work of Chen et al tried to predict the rollover based on Time-To-Rollover (TTR) metric for an articulated heavy vehicle. The TTR metric conducted a “count-down” toward rollover independent of vehicle speed and steering patterns. Basically, TTR is a prediction process to indicate how far the truck is from the rollover threshold as progressing. In this approach, an accurate model significantly faster than real-time was needed. Meanwhile, the TTR predicted by

this model needed to be accurate enough under all driving scenarios. An innovative approach is proposed in this paper to solve this dilemma and the design process is illustrated in an example. First, a simple yet reasonably accurate yaw/roll model was identified. A Neural Network (NN) was then developed to mitigate the accuracy of the model. The NN took the TTR generated by the simple model, vehicle roll angle, and change of roll angle to generate an enhanced NN-TTR index. The NN was trained and verified under a variety of driving patterns. It was found that an accurate TTR is achieved across all the driving scenarios we tested.

Chen considers roll stability based on roll angle and its derivatives.

$$\phi_p = \phi_0 + \dot{\phi}_0 t_p + \frac{1}{2} \ddot{\phi}_0 t_p^2$$

where  $(\phi_0, \dot{\phi}_0, \ddot{\phi}_0)$  are measured or estimated roll angle, roll rate, and roll acceleration respectively.  $\phi_p$  is the predicted roll angle of the semi-trailer and  $t_p$  is the prediction time. When  $\phi_p$  becomes larger than the selected threshold roll angle, the signal-based TTR is set to be  $t_p$ . This is Taylor expansion approximation. To implement, the roll rate is measurable but acceleration is difficult to measure, which needs to be estimated independently from the roll rate for the above estimation to make sense. From our viewpoint, to look at the roll angle would have much less prediction capability, because roll movement is the result of other movement such as longitudinal speed and yaw and yaw-rate. However, it is useful for progressive warning if it is used as the last dam if all the other predictions are failed,

Stevens developed a rollover warning system with on-board instrumentation that measures the roll stability of the trailer continuously and determines the location and probable near-term path of the vehicle. In addition, roadside beacons at selected curves on I-75 broadcast the curvature of the road section. Receiver on the trucks receives the information and an on-board computer estimates rollover risk based on roll stability, vehicle speed and acceleration, and the lateral acceleration demand of the upcoming curve. If estimated rollover risk exceeds a trucking-company-specified threshold, visible and audible warnings were set on to the driver in time for corrective action to avoid rollover.

Rogers et al provide an interesting implementation-oriented set of results, introducing the Freight Line Rollover Advisor, then extending the system. There is in Rogers a simple model for lateral acceleration calculation just based on speed, curvature and elevation. The threat assessment is based on the score of RSA:

$$RSA\_Score = \frac{a_N(actual)}{a_N(critical)}$$

where

$$a_N = \frac{v^2(t)K(t)}{g} - E(t)$$

and  $v(t)$  – longitudinal speed in  $[m/s]$

$K(t)$  – curvature in  $[m^{-1}]$

$g = 9.8[m/s^2]$

$E(t)$  – superelevation as slope in radiant

In the implementation, the superelevation (bank) and curvature is from survey data map.

Measured parameters include:

- Longitudinal speed
- lateral acceleration
- operational parameters (brake and throttle pedal deflections, wiper info)
- Lane marker detection

They generated the road map based on DaimlerChrysler's own GPS system, which was claimed to have improved accuracy for the road map compared to that from NAVTEQ system.

For Freightliner fully loaded trucks, the following threshold applies:



$$a_N(\text{critical}) = 0.225g$$

as the critical lateral acceleration.

### **Implementation Considerations**

For on-line monitoring of the relative rollover stability and predicting the vehicle rollover risk, the feedback signals and some knowledge about the vehicle parameters are needed.

Parameters that primarily characterizes truck roll behavior include

- load mass and distribution – height of CG
- vehicle geometry configuration and characteristics, such as wheel base and the suspension vehicle speed
- lateral acceleration
- front wheel turning angle or the angle difference between tractor and trailer
- yaw/roll angle/rate
- road characteristics: curvature, superelevation
- angular speed difference of left/right wheels on the same axle of the trailer wheel

Based on vehicle dynamics, we propose the following rollover-cause logic sequences:

- ➔ longitudinal speed + road curve (or steering angle)
- ➔ lateral acceleration
- ➔ load transfer
- ➔ trailer outer wheel lift-off
- ➔ tractor outer wheel lift-off
- ➔ rollover

In practical implementation, we propose Three Step Progressive Rollover Warning approach based on above analysis:

**Step 1: Rollover Longer Time Prediction.** Based on the predicted road curvature information from NQVTEQ system, we calculate a potential lateral acceleration using the simplified model:

$$a_N(t) = v(t)^2 / \rho(t)$$

where vehicle speed  $v(t)$  is estimated from wheel speed and instant radius  $\rho(t)$  of the road curve is predicted from NAVTEQ system. Using the lateral acceleration threshold for Freightliner fully loaded trucks (5.3), if  $a_N(t) > a_N(\text{critical})$  is satisfied for certain time steps, a warning is issued.

**Step 2: Rollover Shorter Time Prediction.** This prediction is based on a simplified model based on vehicle longitudinal speed and yaw angle to calculate lateral acceleration as in Step 1. The difference is that the lateral acceleration is measured from IMU instead of from prediction using NAVTEQ system. If  $a_N(t) > a_N(\text{critical})$  is satisfied, a warning is issued immediately.

**Step 3: On the curve instant prediction:** As the last step, it is based on roll angle of the truck. The roll angle measure is from the IMU (Inertia Measurement Unit) which is mounted near the yaw center of the tractor. Instead of using yaw acceleration we use roll angle and roll rate only to predict the potential rollover:

$$\phi_p = \phi_0 + \dot{\phi}_0 t_p$$

If  $\phi_p > 3.5$  [deg], a rollover warning is issued. However, this is only a preliminary implementation. The threshold needs to be calibrated in the next phase. In the future, this could be further improved by mounting the roll angle sensor at the roll center at end of the trailer which will be more direct and faster.

By incorporating more vehicle information into the rollover decision threshold the accuracy and effectiveness of the rollover warning system can be significantly increased.

## 4.1.7 Algorithm Implementation

### Critical Parameters

The critical parameters for implementation of the algorithms are:

$v$  – vehicle speed

$\mu$  – practical tire slip

$\theta$  – road grade

$\varphi, \dot{\varphi}$  – yaw/yaw rate

$\phi, \dot{\phi}$  – roll/roll rate

Target relative distance

Target relative speed

Besides, it is necessary to know in real-time if there are other moving or static objects such as vehicles in the front and the inter-vehicle distance. This requires real-time tracking using remote sensors.

### Sensors

Sensors used for the truck OBM system include:

- Radar: EVT-300
- DENSO Lidar
- Gyroscope
- Inertia Measurement Unit
- Road surface detection for tire slip
- Video Camera
- NAVTEQ System (including GPS)
- J1939/J1857 List: providing most vehicle related measurement including wheel speed, engine, brake, vehicle kinematics, and driver operation information

The set of parameters to be inferred from the sensors include the parameters related to truck kinematics: speed, acceleration, steering angle, fuel rate, braking system (pneumatic brake, engine brake and transmission retarder) use, lane keeping information from NAVTEQ system.

### **Parameter Estimation from Target Tracking**

Front multiple-target tracking is an active topic for many years for Frontal Collision Warning Systems development.

Sensors are mainly used for the following purposes:

(1) Detection of road surface condition for tire slip: A commercially available camera and other sensor based road surface detection system will be used to detect road surface condition in real-time. This information will be fused with ambient temperature detection and luminance detection for more reliable estimation of tire slip.

(2) Road grade information: This is obtained in real-time by using NAVTEQ System, which has GPS location of the vehicle. This location data is compared with the internal road map which provides road information including the number of lanes, lane number curvature and grade.

## **4.2 Fatigue and Inattention Detection**

### **4.2.1 Introduction**

Any error, failure, or lapse of attention may lead to a crash. These errors may be related to the driver's energetic or alertness state and are described more fully in Section 2.0 of this report. As a consequence, it is important to investigate the detection approaches on driver fatigue and inattention.

A brief review of the past studies on fatigue and inattention monitoring is provided in Section 4.2.2. In the OBMS prototype implementation described in Section 4.0, the SafeTrac system and its lane keeping monitor was used as a surrogate, since despite the body of research described in

the next section, reliable methods and products beyond the relatively straightforward, simple (and at best, modestly effective) systems like SafeTRAC were not available, at least at the time of selection. However, as a research element to the OBMS project, a set of relatively straightforward fatigue and inattention schemes – while not implemented due to its complexity – was researched; this uses the concepts and ideas for systems as SafeTRAC as a “point of departure”. The remainder of this section describes the development of these detection schemes. These schemes are entirely based on the existing approaches in literature and are slightly modified in order to be adapted to the environments of the truck and the OBM system.

#### 4.2.2 Literature Review

Without directly monitoring the driver’s psychological and physiological states, such as electroencephalogram (EEG), eyes-off-the-road time, and blink rate, the past studies in literature focused on driver model, driving performance statistics, and driving behavior analysis. These approaches are reviewed as follows:

Driver Model: A well-known result from human factors research is the “crossover model”. The crossover model states that the open loop frequency response of the driver-vehicle combination approximates that of transfer function  $\omega_c / s$  around the crossover frequency, where  $\omega_c$  is the crossover frequency. More precisely, the open loop driver-vehicle combination approximate  $(\omega_c / s)\exp(-\tau_E s)$  around  $\omega_c$ , where an effective time delay of the driver,  $\tau_E$ , is included. Some other models have similar characteristics around the crossover frequency and differ more at higher and lower frequency ranges. Figure 4-3 shows such a driver model proposed by Hess et al. In the figure,  $y_R(t)$  denotes the lateral position of current road centerline in the global reference frame and  $y_V$  is the vehicle lateral position relative to the global reference frame. The driving task is to keep the difference,  $e_A = y_R - y_V$  near zero. The output of the driver model is the steering wheel angle, denoted as  $\delta_{sw}$ .

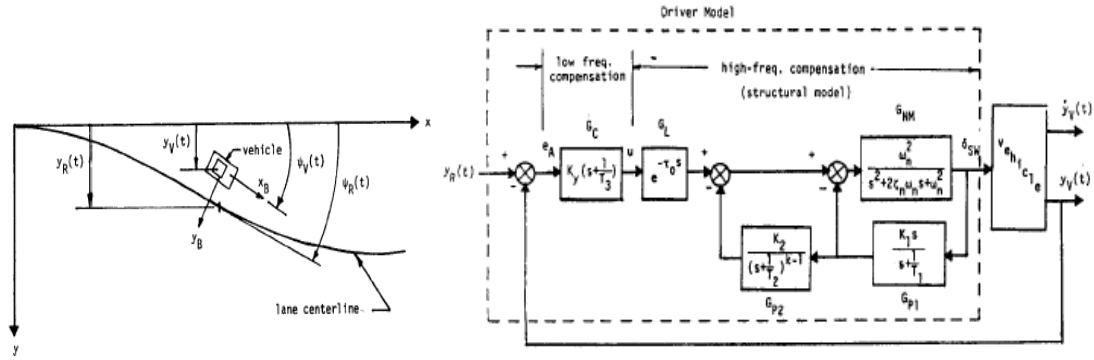

**Figure 4-3. Different Realizations of “Crossover Model”**

Kiencke et al. developed a hybrid driver model for modeling and analyzing the driver’s handling of both the lateral and longitudinal motion of the vehicle. It consists of four parts: queuing system, selection, reference variables, and controller. The hybrid model combined discrete event system and the classical control. It tries to handle all the cognitive processes of the human operator in order to mimic a real driver behavior, which can be used in vehicle/driver simulations. The block diagrams in Figure 4-4 show the idea of hybrid driver model.

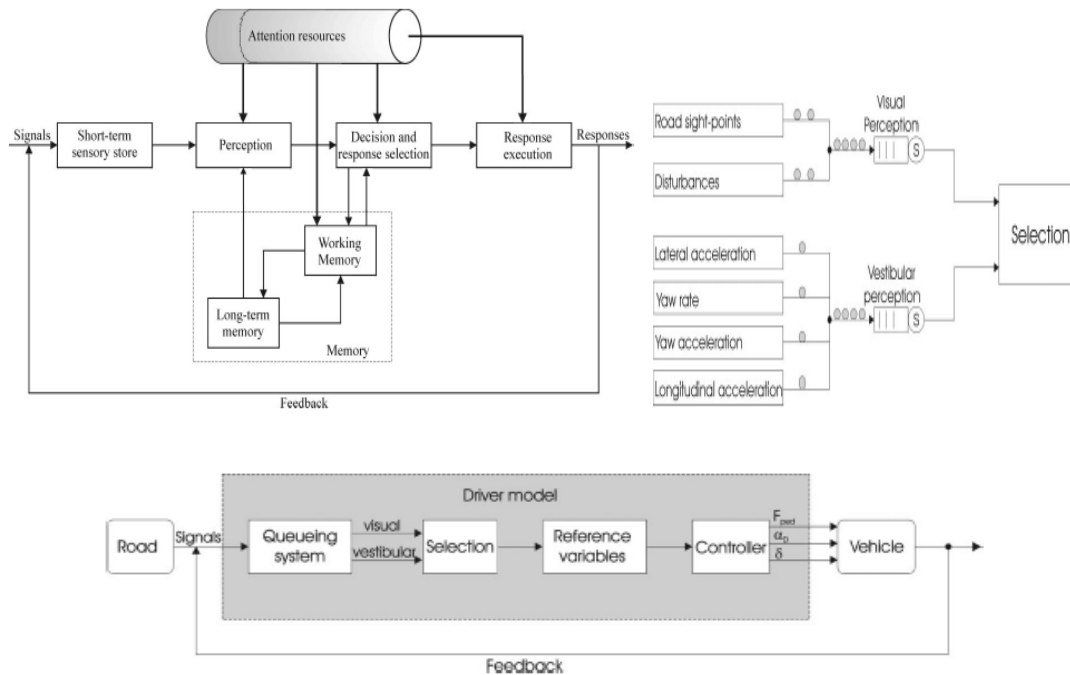

**Figure 4-4. Human Information Processing Model**

Chen and Ulsoy have proposed to use an ARMAX (auto-regression moving average with exogenous inputs) model as the driver model structure. Based on statistic analysis of

experimental data, it was found that the input (lateral position) and output (steering angle) has a good coherence up to 1 Hz, which indicate that a linear model can characterize human driving adequately from the control point of view. The basic structure of ARMAX models is depicted in Figure 4-5(a). One advantage of this model structure is a rich body of knowledge available in the field of modeling and identification of dynamic systems. Another advantage of the model is that some of its coefficients have clear physical interpretation; for example, the delay time may be estimated based on the number of vanishing coefficients of the moving average portion of the model, and the delay time may be interpreted as the driver's response time, that the driver needs before initiating a corrective action after visual observation. Chen and Ulsoy also introduced nonlinearity (dead zone) in the model to further reduce errors between modeling and experiments, as shown in Figure 4-5(b). They used the lateral position of the center of gravity of the vehicle as the input to the human driver model. This selection is not realistic, and their results include aspects, which are not consistent with basic limitations of the human driver.

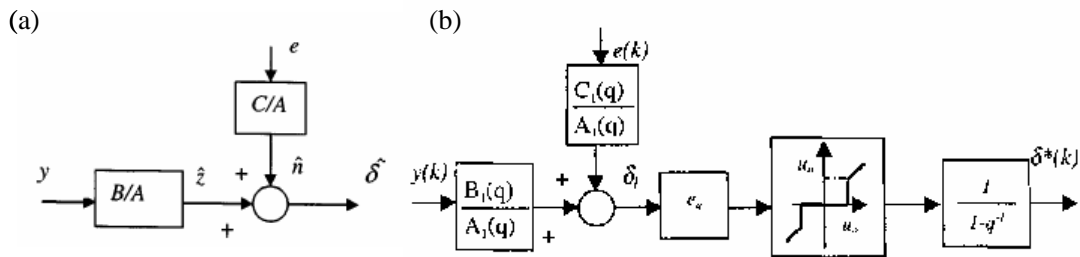

**Figure 4-5. Driver Model Using ARMAX Structure**

However, the fatigue/inattention detections based on driver models are not yet mature and have many limitations. The difficulties of the driver model based approach will be delineated in the subsequent subsection describing the problem.

Driving Performance: A suggested list of impairment of criteria was proposed by Brookhuis et al. They characterized criteria in terms of absolute levels (i.e. the cut-off point which defines impaired driving) and relative change (i.e. the relative change which indicates a significant change in individual driver performance) based on driving performance. The proposed criteria shown in Table 4-5 were divided into three areas: following too close, straddle lanes, and driving

too fast. These events are defined as follows:

- Following too close: characterized as tailgating where the temporal separation between the vehicle and the lead vehicle is evaluated.
- Straddle lanes: characterized by an increase of the lateral deviation of the vehicle.
- Driving too fast: characterized by exceeding the legal speed limit.



**Table 4-5. Definition Criteria for Following too Closely, Straddling Lanes and Driving too Fast**

	<b>Absolute Change</b>	<b>Relative Change</b>
Following too close:		
Time headway to lead vehicle (TTC)	<0.7 s	-0.3 s
Straddle lanes:		
Steering SD	>1.5°	+0.5°
Lateral deviation (SD) of the vehicle	>0.25 m	+0.04 m
Minimum time-to-line crossing (TLC) – right lane	<1.3 s	-0.3 s
Minimum time-to-line crossing (TLC) – left lane	<1.7 s	-0.2 s
Median TLC – right lane	<3.1 s	-0.7 s
Median TLC – left lane	<4.0 s	-1.4 s
Driving too fast:		
Vehicle speed	Limit+10%	Limit+/- 20%

Driving Behaviors: This approach is derived from the observation on driving characteristics. Steering entropy is one such attempt (Nakayama et al.). It was observed that as the driver performed other tasks while driving, steering variance increases and bandwidth of steering input decreases when compared with the so-called “baseline” driving behavior. During the experiments, drivers had various strategies to adapt differently to the tasks rather than driving. As a result, magnitude-only or frequency-only metrics to detect driver inattention could be applied to some samples but failed for other samples. Steering entropy method may not have such problems. Another attempt by Desai et al. is to utilize the time derivative of force exerted by the driver at the vehicle-human interfaces can be used to construct a signature of individual driving styles and to discern different levels of alertness. In this study, a parameter, spikiness index, was introduced for the time series data of the force derivative to quantify driver alertness.

### 4.2.3 Problem Description

From a dynamical system perspective, if a driver is regarded as a nonlinear time-varying multiple-input-multiple-output (MIMO) system, Figure 4-6 shows the general interactions in a typical driver-vehicle system. A driver gives commands to the vehicle based on the vehicle states and the external factors, such as his desired trajectory, road conditions, side vehicles, obstacles, and so on. Besides the vehicle states and the external disturbances, the psychological and physiological factors of the driver can also impact the driver's commands. The difficulties of the driver fatigue and inattention monitoring lie on the following issues:

- (1) The structure of the comprehensive driver model is not sophisticated yet. There is no guarantee that using typical system identification approaches to identify driver fatigue/inattention with an incorrect model structure would lead to correct results.
- (2) The parameters of the driver model can be time-varying. This increases the difficulty of the system identification heavily.
- (3) Note that fatigue/inattention is only part of these psychological and physiological factors. Without investigation on the influence of other physiological and psychological factors, it is highly possible that one of these factors can have very similar driving characteristics to those under fatigue/inattention.
- (4) Some inputs, such as pedestrian, obstacle, and pot hole, are generally not acquired in such fatigue/inattention monitoring systems. These factors can also affect the driving characteristics significantly.
- (5) Since the driver perceives many inputs and processes them during driving within each short period of time, the parameter identification task may fail due to the insufficient richness of the input signals. Furthermore, in order to identify parameters for a nonlinear system, the system may need to experience various operational conditions.

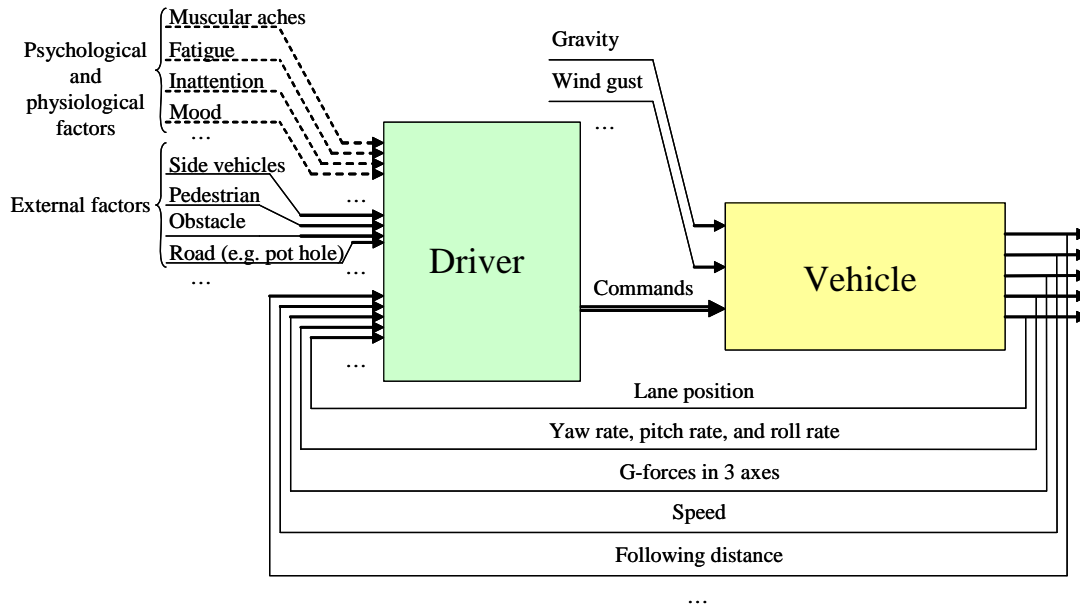

**Figure 4-6. General Driver-Vehicle Interactions**

This section is not aimed at developing a new fatigue/inattention detection technique. Instead, it utilizes the combination of above-mentioned approaches to generate the associated metrics in order to identify possible fatigue/inattention. The basic requirements of such monitoring schemes include:

- (1) Using onboard vehicle sensors only,
- (2) Less computation time,
- (3) Sufficient adaptation capability or robustness to different drivers.

The correlation between these metrics and the driver fatigue/inattention will be further evaluated in the FOT .

#### **4.2.4 Driver Fatigue Detection**

The driver fatigue monitoring in this study is divided into two parts: using the dedicated COTS system and employing the driving performance measures. The COTS system installed on the prototype truck is SafeTRAC made by AssistWare. It is essentially a camera-based lane departure warning system. This system can provide warnings upon the following events:

roadway departure, unsignaled lane change, and unsatisfactory driver alertness. It provides an alertness index that scores a driver’s lane-keeping performance based on TLC, lane departures, and lane position deviations. If driving turns out to be unpredictable or inconsistent, the alertness index drops. This can alert the driver to pay more attention. When the index is under a predetermined value, the system will give the driver a warning. This warning signal and the score are recorded in the OBM system as the fatigue measures.

The driving performance measures of interest are the lane-keeping capability and the throttle angle usage. Based on the criteria in Section 4.2.2, one of the important metrics is the standard deviation of the lane position. However, it is generally very difficult to set a single threshold to identify the driver alertness status as “fatigue” or “normal”. Such a threshold would lead to false alarms or missed detections easily. For example, suppose that the driver alertness levels can be quantified from 0% to 100% and Figure 4-7 shows the respective probability density functions of the standard deviations of lane positions (SDLP) for the alertness levels of 25%, 70%, and 100%<sup>3</sup>. By comparing the driving performance between the alertness levels of 25% and 100%, it is easy to identify the driver fatigue by setting a single threshold. However, this single threshold strategy will not work when the alertness level falls in between, e.g. 70%. This example indicates that such a strategy based on a single threshold would not be able to monitor driver fatigue.

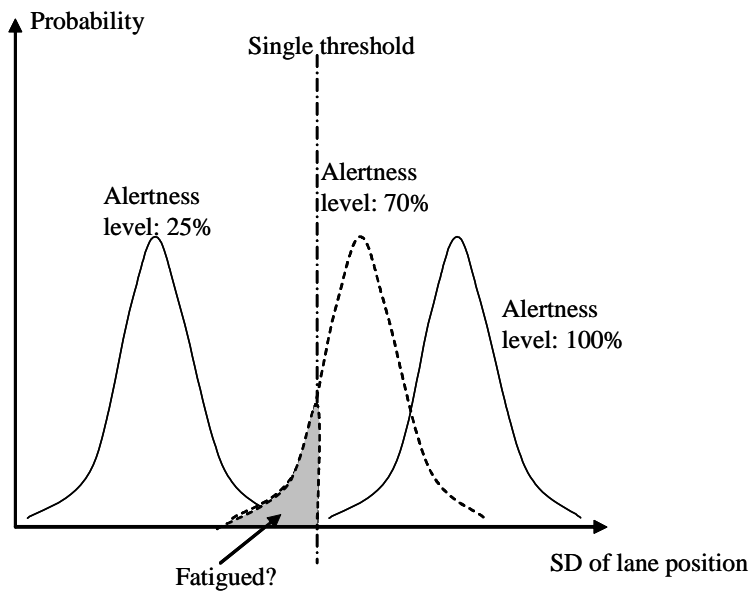

**Fig. 4-7. Probability Distribution of SDLP of the Driver with Different Levels of Alertness**

<sup>3</sup> These alertness indices are only used to present the driver status for exemplary purpose.

A better approach is to define the fatigue flags for different levels of the SDLP. Introducing two more intermediate states and a few basic rules can help identify the driver fatigue. Figure 4-8 illustrates an example of different driver alertness states based on the SDLP. The fatigue flags are defined by:

$$\left\{ \begin{array}{ll} \textit{fatigue\_flag} = 0 \text{ (Normal)} & \text{if } m_3 > \textit{SDLP} \geq 0 \\ \textit{fatigue\_flag} = 1 \text{ (Not yet determined)} & \text{if } m_2 > \textit{SDLP} \geq m_3 \\ \textit{fatigue\_flag} = 2 \text{ (Possible fatigue)} & \text{if } m_1 > \textit{SDLP} \geq m_2 \\ \textit{fatigue\_flag} = 3 \text{ (Fatigue)} & \text{if } \textit{SDLP} > m_1 \end{array} \right.$$

where  $m_1 > m_2 > m_3 > 0$ ,  $m_1, m_2, m_3 \in \mathbb{R}$ .

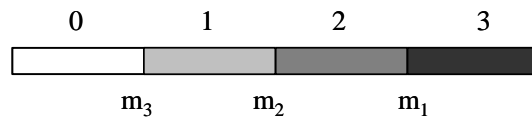

**Figure 4-8. Fatigue Flags Based on SD of Lane Deviation.**

The decision-making scheme is mainly based on the criterion in Figure. 6. In order to decrease the probabilities of false alarms, some more heuristic rules are integrated into the decision-making scheme. The rules are summarized below:

- (1) If the fatigue state stays in “possible fatigue” exceeding a predetermined period, the state will be set to “fatigue”.
- (2) If the state is “not yet determined” for some time and if the driver keeps on driving, the fatigue flag becomes “possible fatigue”.
- (3) If the state falls into “fatigue” immediately followed by “normal”, the fatigue flag will show “possible fatigue”.

#### 4.3.5 Driver Inattention Monitoring

The driver inattention in this study is evaluated by using the steering entropy. The steering entropy algorithm mainly includes two components: prediction error filter and a nonlinear weighting of the prediction errors (Boer et al. 2005). The key concept is to compare driving characteristics between the current condition and the so-called “baseline” condition. The baseline driving with respect to the current condition refers to the condition under which the driver focuses on driving: (1) without performing other tasks, (2) in the same driving course, and (3) with the same speed profile. However, it is not possible to have the driver driving in the same course at the same time twice. In addition, since the driving conditions and the environments vary from time to time, it may be “unfair” to evaluate the characteristics at different times. As a result, using the low-pass steering input as the baseline driving characteristic is proposed.

There are two versions of prediction error (PE) filters: the original PE filter (Nakayama et al, 1999) and the modified PE filter (Boer et al, 2005). The modified PE filter is a third-order autoregressive (AR) filter and the original PE filter can be viewed as the moving-average (MA) version of the modified PE filter. The difference between these two filters lies on the low-frequency amplification (below 0.3Hz). Figure 4-9 shows the frequency response of the original filter used in this study. This filter is a high-pass filter and it amplifies the high frequency contents of the steering input beyond 0.7Hz. The reason why the modified PE filter is not employed is because of the way the baseline steering signal is generated. Since a low-pass filter is applied to the current steering data in order to provide the baseline steering signal, there is no difference at low frequencies between these two signals. The discrepancy between them lies on the high-frequency contents.

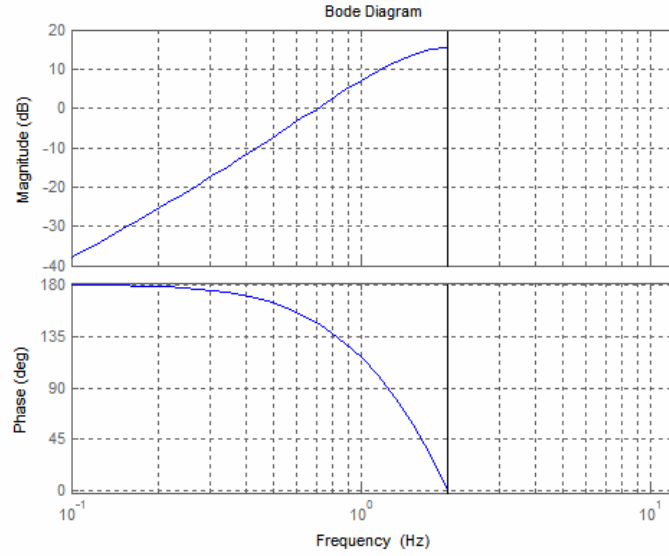

**Figure 4-9. Frequency Response of the Original PE Filter with Sampling Frequency of 4Hz**

The nonlinear weighting function places an extra focus on extreme prediction errors with respect to the baseline driving characteristic. Any strong and fast steering input would cause higher steering entropy. This nonlinear weighting function is summarized as follows: The prediction errors under the baseline driving and the current driving conditions are sorted into 14 sets. A prediction error  $e[n]$  at epoch  $n$  belongs to the  $k$ -th set for  $k = 1, 2, 3, \dots, 14$ , if

$$\left\{ \begin{array}{l} e[n] < -6e_{\alpha} \Rightarrow k = 1 \\ 6e_{\alpha} < e[n] \Rightarrow k = 14 \\ \text{otherwise, } k = \arg\{(i-7)e_{\alpha} \leq e[n] < (i-6)e_{\alpha}\} + 1 \end{array} \right. ,$$

where  $e^{\alpha} = \frac{\left| \arg\{CDF(e) = \alpha\} \right| + \left| \arg\{CDF(e) = 1 - \alpha\} \right|}{2}$  with  $\alpha = 0.2$ . CDF stands for the

cumulative probability density function. The steering entropy is given by:

$$S_{steering} = \frac{\sum_{k=1}^{14} [-P_k^{current} \log_2(P_k^{baseline})]}{N} ,$$

where  $P_k^{current} = \frac{N_k^{current}}{N}$ ,  $P_k^{baseline} = \frac{N_k^{baseline}}{N}$ , and  $N$  is the number of the total samples during this period.  $N_k^{current}$  is the number of the elements in the  $k$ -th set for the current driving condition. Similarly,  $N_k^{baseline}$  is for the baseline driving condition

Figure 4-10 shows the block diagram of the driver inattention monitoring algorithm. The steering signals are fed independently into two filters: one with the PE filter and the other with the PE filter and an additional low-pass filter. The nonlinear weighting block employs the current and the baseline prediction errors to compute the steering entropy. This steering entropy will be recorded as an index of the driver inattention. Similarly, the corresponding decision making rules and inattention flags are similar to those proposed in Section 4.2.2.



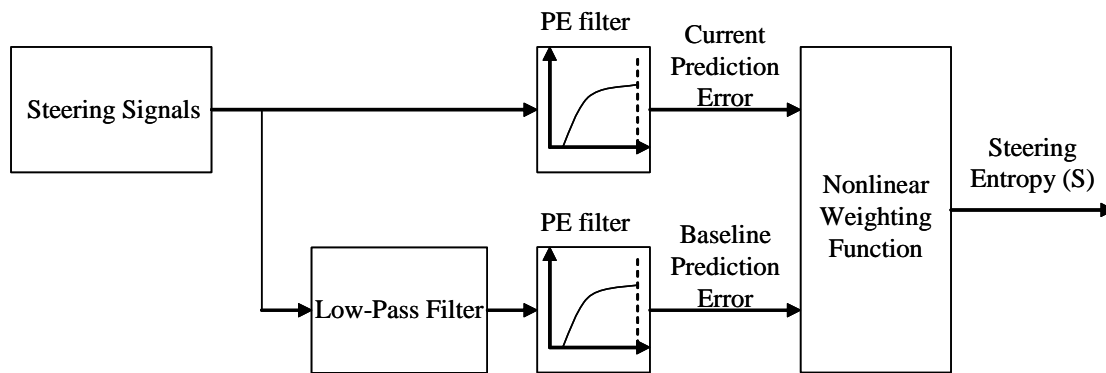

**Figure 4-10. Block Diagram of Implemented Inattention Detection Algorithm**

#### References (Section 4):

Ashley L. (Al) Dunn and Richard L. (Dick) Hoover, Class 8 Truck Tractor Braking Performance Improvement Study, Report – 1, Straight Line Stopping Performance on a High Coefficient of Friction Surface, U.S. Department of Transportation National Highway Traffic Safety Administration, DOT HS 809 700 May 2004,

Baker, D., Bushman,R., and Berthelot, C., The Effectiveness of Truck Rollover Warning Systems, University of Saskatchewan, Department of Civil Engineering, August 2000

Bar-Shlom, Y, T. E. Frotmann, *Tracking and Data Association*, Academic Press INC, New York, 1988

Breivik, T., 2000, Early Detection of Rollover in Large Vehicles, *June 2000 Postgraduate Colloquium*, Department of Mechanical Engineering, University of Glasgow, Glasgow, G12 8QQ, U. K.

Chen, Bo-Chiuan, Peng, H. “Differential-Braking-Based rollover prediction for sport utility vehicles with human-in-the loop evaluations,” *Vehicle System Dynamics*, Vol. 36, N0. 4-5, November 2001, pp 359-389.

Chen, B.-C. and Peng, H., Rollover Warning for Articulated Heavy Vehicles Based on a Time-to-Rollover Metric, Transactions of the ASME, Vol. 127, SEPTEMBER 2005, p.406-414

Chui, C. K. and Chen, G., 1999, Kalman Filtering, with Real-Time Applications, Third Edition, Springer, Berlin

Ralph Craft, Rear-End Large Truck Crashes, FMCSA, <http://www.fmcsa.dot.gov/facts-research/briefs/Rear.html>

Ervin, R., Winkler, C., Fancher, P., Hagan, M., Krishnaswami, V., Zhang, H., Bogard, S., Karamihas, S., 1998, "Cooperative Agreement to Foster the Deployment of a Heavy Vehicle Intelligent Dynamic Stability Enhancement System," UMTRI-98-3, University of Michigan Transportation Research Institute, Ann Arbor, MI.

Forkenbrock, D. J., and Hanley, P. F., Fatal crash involvement by multiple-trailer trucks, Transportation Research, Part A, 37(2003), 419 - 433

Freedman, M., Olson, P. L., and Zador, P. L., 1992, "Speed Actuated Rollover Advisory Signs for Trucks on Highway Exit Ramps," Insurance Institute for Highway Safety and University of Michigan Transportation Research Institute.

Garrott, W. R., Rhea, B., Subramanian, R., and Heydinger, G. J., The Rollover Propensity of Fifteen-Passenger Vans, U.S. Department of Transportation National Highway Traffic Safety Administration, April 2001

Frederick County Highway Safety Task Force,  
<http://www.xecu.net/hwysafety/nozone.html#table>

James Madison University, General Driver Training Outline & Supportive Materials, Accessed at: <http://www.jmu.edu/safetyplan/vehicle/generaldriver/>

- Kamnik, R., 2000, Rollover of Heavy Freight Vehicles, June 2000 Postgraduate Colloquium, Department of Mechanical Engineering, University of Glasgow, Glasgow, G12 8QQ, U. K.
- Kostyniuk, L.P., F.M. Streff and J. Zakarajsek (2002). *Identifying Unsafe Driver Actions the Lead to Fatal Car-Truck Crashes*, AAA Foundation for Traffic Safety, Washington, DC.
- Lee, K and Peng, H., 2005, Evaluation of automotive forward collision warning and collision avoidance algorithm, *Vehicle System Dynamics*, Volume 43, Number 10, October, pp. 735-751(17)
- Lee, Y., Yang J. H., Feron, E., and Kulkarni, 2003, Development of performance based approach for a rear-end collision warning and avoidance systems for automobiles, Proc. of Intelligent vehicle Symposium, June 9-11, Ohio, USA, p316-321
- X. Y. Lu, Y.Q. Zhang, J. Chang, D. Marco, S. Johnston, W. B. Zhang, and S. Shladover, Quantitative Test for Frontal Collision Warning Systems of Transit Buses, Proc. of 12<sup>th</sup> ITS World Congress, Nov. 6-10, 2005, San Francisco, California
- X. Y. Lu and S. Shladover, Data Fusion for Vehicle Detection Using Loops and Radar for IDS, Proc. of 12<sup>th</sup> ITS World Congress, Nov. 6-10, 2005, San Francisco, California
- Maybeck, P. S., *Stochastic Models, Estimation, and Control*, **Vol. 1**, Academic Press, New York, 1979
- McGee, H., Joshua, S., Hughes, W., Strickland, R., Bareket, Z., and Fancher, P., 1993, "Feasibility of An Automatic Truck Warning System," FHWA-RD-93-039, U.S. Department of Transportation, Federal Highway Administration, Research and Development, Turner-Fairbank Highway Research Center, McLean, VA.
- Mobus, R., A. Joos and U. Kolbe, Multi-target multi-object radar tracking, Proc. IEEE Intelligent Vehicles, IV-2003, 489-494

- H. Nishira, T. Kawabe and S. Shin, Road friction estimation using adaptive observer with periodical  $\sigma$  - modification, Proc. IEEE Int. Conf. on Control Application., Hawai'i, USA, Aug., 22-27, 1999, p.662667
- Preston-Thomas, J., and Woodrooffe, J. H. F., 1990, "A Feasibility Study of a Rollover Warning Device for Heavy Trucks," TP 10610E, Transport Canada.
- Rogers, S. and Zhang, W., Development and Evaluation of a Curve Rollover Warning System for Trucks, IEEE, 2003
- Highway Design Manual, CA DOT (Caltrans), 1995
- Stevens, S., A Truck Rollover Warning System – Preliminary Results, Scott March 2000, Prepared by the OAK RIDGE NATIONAL LABORATORY, Oak Ridge, Tennessee
- Strickland, R., and McGee, H., 1998, "Evaluation of Prototype Automatic Truck Rollover Warning Systems," FHWA-RD-93-039, U.S. Department of Transportation, Federal Highway Administration, Research and Development, Turner-Fairbank Highway Research Center, McLean, VA.
- Trent, V. and Greene, M., A Genetic Algorithm Predictor for Vehicular Rollover, IEEE 2002 28th Annual Conference of the Industrial Electronics Society, (IECON 02), Nov. 5-8, 2002
- X. Q. Wang, W. B. Zhang, S. Johnston, D. Empey, C.-Y. Chan, Integrated multi-sensor-system: a tool for investigating approaches for transit frontal collision mitigation, 2001, ITS World Congress
- Boer, E., Rakauskas, M. E., Ward N. J., and Goodrich, M., "Steering Entropy Revisited" in Proceedings of the Third International Driving Symposium on Human Factors in Driver Assessment, Training, and Vehicle Design, June, 2005.

- Brookhuis, K. A., Waard, D. De., and Fairclough, S. H., "Criteria for Driver Impairment", *Ergonomics*, Vol. 46, No. 5, 2003.
- Chen L.-K., and Ulsoy, A. G., "Identification of a Driver Steering Model, and Model Uncertainty from Driving Simulator Data", *ASME Journal of Dynamic Systems, Measurement, and Control*, Vol. 123, December, 2001.
- Desai, A.V, Haque, M. A., "Vigilance Monitoring for Operator Safety: A Simulation Study on Highway Driving", *Journal of Safety Research*, Vol. 37, pp.139-147, 2006.
- Hess, R. A., Modjtahedzadeh, A., "A Control Theoretic Model of Driver Steering Behavior", *IEEE Control Systems Magazine*, pp.3-8, August, 1990.
- Kiencke, U., Majjad, R., Kramer, S., "Modeling and Performance Analysis of a Hybrid Driver Model", *Control Engineering Practice* 7, pp. 985-991, 1999.
- Nakayama, O. Futami, T., and Nakamura, T., "Development of a Steering Entropy Method for Evaluating Driver Workload", *SAE Paper no. 1999-01-0892*, 1999.

## **5 ONBOARD MONITORING PERFORMANCE**

### **5.1 Driver Feedback**

#### **5.1.1 Overview**

The overall purpose of this section was to document the Driver-Vehicle Interface (DVI) designs that were developed for and used in the prototype OBMS. The OBMS is not a single integrated system, but as described in Section 3.0 an integration of COTS systems and sensors that provide the driver with feedback, situational awareness, and warnings.

The results of the question and answer group discussion (detailed in Section 2.6) highlighted the need to provide drivers with real-time monitoring feedback. The drivers interviewed in this project showed a strong and clear preference for systems in-the-cab that could aid them with real-time feedback so that unsafe behaviors could be immediately corrected. In creating the prototype system, real-time feedback was given the priority; however, this section also includes some discussion on which parameters might be better suited for off-line feedback.

One of the goals of this project was to use as many COTS monitoring devices as possible, and to avoid redesigning COTS warning systems and algorithms. In selecting the suite of COTS systems and sensors to be used in the OBMS prototype, the COTS system DVI was only one consideration, and thus, DVI was less than ideal given the current state of research. This section serves three goals:

1. To compare DVI design and functionality across COTS systems and recent FOT systems.
2. To document the DVI design and functionality of both the COTS devices and monitoring feedback as built in the OBMS prototype.
3. To suggest DVI enhancements and additional necessary features that should be considered for an OBMS FOT.

Some of the COTS devices used in the prototype design serve multiple functions, e.g., the Eaton Vorad system provides both following distance feedback and forward collision warnings. Some

of the parameters being monitored may have multiple interpretations, e.g., frequent forward collision warning activations might indicate either frequent following too close or frequent inattention. Nevertheless, an attempt has been made to group the OBMS system functionality (from the driver’s point of view) and DVI design discussion into six categories, realizing that the categories are not mutually exclusive and that any specific parameters being monitored may be used in more than one monitoring application:

1. Speed
2. Following
3. Attention and Fatigue
4. Good Driving Safety Practice
5. Incident Recording and Review
6. Off-Line Feedback and Reporting

### 5.1.2 Monitoring Speed: Intelligent Speed Adaptation (ISA)

#### ISA Research Summary and Design Comparison

The concept of speed monitoring or Intelligent Speed Adaptation (ISA) is not new, but the research that has been conducted on the topic primarily comes from outside the U.S. At least two ISA field experiments using prototype systems have been conducted in Europe (Brookhuis and de Waard, 1999, and Várhelyi and Mäkinen, 2001), and the second study eventually moved to an FOT (Várhelyi, Hjälmdahl, Hydén, and Draskóczy, 2004). Additionally, one recent FOT has been conducted in Australia, the TAC SafeCar Project (Young, Regan, Triggs, et al., manuscript 2006). The details of these studies are show in Table 5-1.

**Table 5-1. ISA Driver Feedback Design in Recent International FOT Efforts.**

Study	Type/Size/Technology	ISA Driver Feedback		
		Visual	Audio	Haptic
Brookhuis & de Waard (1999)	- Experiment with 24 drivers - 35 min route - Vehicle-Infrastructure	Digital Speed Green/Amber/Red Color Coding	Initial Voice	

	Comm.			
Várhelyi & Mäkinen (2001)	- Experiment with 60+ drivers - 30 km route - Vehicle-Infrastructure Comm.			X
Várhelyi, et al. (2004)	- FOT with 284 cars ~1 year - GPS/Map Database			X
Young, et al. (2006)	- FOT with 23 cars - 16,500 km each - GPS/Map Database	Speed Limit Sign (Flashing)	Initial Tone	X

Both studies utilizing auditory feedback provided some leeway (10 percent for Brookhuis & de Waard, 1999, and 2 km/h for Young, et al., 2006) before the voice or tone was initiated. Continuous auditory feedback was not used in any of the studies. Haptic feedback was given in the form of Accelerator Pedal Pushback; however, in the Várhelyi & Mäkinen (2001) experiment, the APP was supplemented with the use of a speed governor. While the subsequent FOT used haptic APP alone with some overall success, other recent studies such as Neurauter (2004) have found little positive effect when using APP alone. In fact, for curve speed warning applications, APP alone might even have a negative impact on speed reduction as the driver's tendency when encountering accelerator pedal resistance might be simply to push harder.

Most of the COTS truck or truck driver monitoring devices reviewed in this project (XATA, Delphi, APPlus, Cadec, QualCOMM, DriveCAM, AllTrackUSA, and DriveDiagnostics) recorded speed; however, none of them were coupled with a system that could understand what the current speed limit was. Real-time feedback on speed to the driver was limited to auditory beeps at predefined speed ceilings. Alternatively, some of these systems could work in conjunction with a speed governor limiting the top speed of the truck to a predefined value. One fleet interviewed in this project used the XATA system in conjunction with a speed governor set to 58 mph for California in-state operations (where the maximum speed for trucks is limited to 55 mph) and 62 mph for interstate operations (where the maximum speed for trucks might be as high as 65 mph).

As a final design consideration, seat based vibrations (haptic warnings) have been tried with limited comprehension success for curve speed warnings (Kochhar, and Tijerina, 2006). The



study concluded that drivers did not naturally relate seat vibrations with excessive speed or approaching curves.

### OBMS Prototype ISA Feedback Design

The ISA driver feedback design conceived and implemented for the OBMS prototype assumed the utilization of a High Head-Down Display (HHDD) and is shown in Figure 6-1. The design utilized a multistage warning. In the first stage, continuous visual feedback on speed was provided by replicating the vehicle's speedometer and adding a two stage alarm bar (similar to the display concept of a red-line in a typical tachometer). The amber boundary would indicate recommended speed (45 mph in the figure) while the orange boundary would indicate speed limit (55 mph in the figure), with the assumption that recommended speed might be lower than the current speed limit based on factors such as an approaching curve, weather (rain, snow, or ice), road grade, or current traffic conditions. These speed reducing factors would be displayed at the bottom of the screen to give drivers a sense of why the recommended speed was less than the current speed limit.



**Figure 5-1. OBMS Prototype ISA Visual Feedback Design**

A second stage warning could be given in the form of a flashing text message at the top of the screen (possibly in conjunction with an auditory alert) if the vehicles speed exceeds the recommended speed or the speed limit by more than a specified threshold for a specified period of time. For the prototype demonstration, the thresholds were nominally set at 5 mph and 0 seconds.

### OBMS ISA FOT Recommendations

One issue that will need to be addressed before deploying this type of ISA system in a FOT will be the desired trade-off between alarm annoyance, alarm compliance, and driver acceptance of the system. In general, the more annoying the alarm, the higher the compliance, but the less accepting drivers will be of the system. The prototype utilized a configurable speed and time “grace” threshold before escalating the warning and recording an incident, and these thresholds will need to be fine-tuned with feedback from any potential FOT partner’s management and drivers, as well as direction from both FMSCA and Caltrans.

Another issue that will need to be addressed during a FOT is the potential for the system to incorrectly determine the speed limit or incorrect speed. This could occur due to map database errors, poor GPS, or incorrect map matching. If such an error occurs, the driver will need a button to press to cancel the alarm and report the error for further review.

### **5.1.3 Monitoring Following Behavior**

#### Research Summary and Design Comparison

There have been a number of FOTs (and a number of COTS devices) utilizing following distance feedback (often combined with forward collision warnings). Table 5-2 compares the interfaces developed for five products or FOT efforts relating to following distance (time-gap) and forward collision warnings. The first product compared was the Eaton Vorad EVT-300 which is perhaps the most widely used COTS system available on many new trucks to provide both following time-gap and forward collision warnings. The ACAS FOT (Automotive Collision Avoidance

System) was sponsored by NHTSA, designed by General Motors (GM), and tested by the University of Michigan Transportation Research Institute (UMTRI) (Ervin, Sayer, LeBlanc, et al., 2005). Shinar and Schechtman (2001) conducted a long-term experiment with teen drivers providing following distance feedback. Finally, there have been two very recent following distance feedback FOTs, one in Australia (the TAC SafeCar Project by Young, Regan, Triggs, et al., 2006) and one in Europe (the Netherlands) using the COTS Mobile Eye system (Alkim, 2006).

**Table 5-2. Following Distance (Time-Gap) Driver Feedback Design in FOT Efforts.**

<b>COTS Device / FOT</b>	<b>Visual Display</b>	<b>Visual Warnings</b>	<b>Auditory Warnings</b>
Eaton Vorad EVT-300	3 LEDs Horizontally Yellow/Amber/Red	Yellow - TG > 2 s Orange - TG < 2 s Red - TG < 1 s Red - Coll. Warning	- Proximity: Double Beep - TG < 2 s: Single Beep - TG < 1 s: Single Beep - TG < 0.5 s: Continuous - Coll. Warning: Single Beep
ACAS FOT (GM & UMTRI, 2005)	- Looming Car Icon - 6 Stages: 1 Turquoise 4 Amber 1 Red	- Turquoise: Target Detected - Amber: Increasing Threat - Red Flashing: Imminent Coll.	Constant Beeps at Imminent Threat Level
Shinar & Schechtman (2001)	Digital Time-Gap displayed in (s)	Warning Icon at TG < 1.2 s	Beep at TG < 0.8 s
Australian TAC SafeCar (2006)	- Inverted Trapazoid - 3 Yellow Levels - 3 Red Levels	- Yellow: TG > 1.3 s - Red Flashing: TG < 1.3 s	TG < 1.1 s
Mobile Eye Dutch Ministry of Transportation FOT (in Progress)	- Digital Time-Gap displayed in (s) - Color Car Icon: Green/Amber/Red	- Green: TG > 1.0 s - Amber: 0.6 < TG < 1.0 s - Red: TG < 0.6 s - Flashing Red: Collision Warning	- TG < 0.6 s: Single Beep - Collision Warning Continuous Beep

Although none of the FOTs used the haptic modality for warnings, there has been much research on haptic warnings, and there has been some success with the comprehension of haptic warnings for forward collision warning applications (Kochhar, and Tijerina, 2006). This study concluded that shaking the seat pan (and optionally the seat back) in unified pulses was mostly associated with a general urgency and directed the driver's attention to the forward scene.

### OBMS Prototype Feedback Design

The OBMS prototype used the COTS Eaton Vorad EVT-300 for forward collision warning and auditory following distance alerts. However, since the EVT-300 had the most simplistic and nondescript visual interface (a series of three LEDs), the feedback was supplemented using the best aspects of the designs reviewed. As shown in Figure 5-2, a digital display of the following time-gap that was color coded to a looming car icon was added. Similar to the recommended speed display, factors influencing the recommended following distance, such as road conditions or grade, were also displayed.

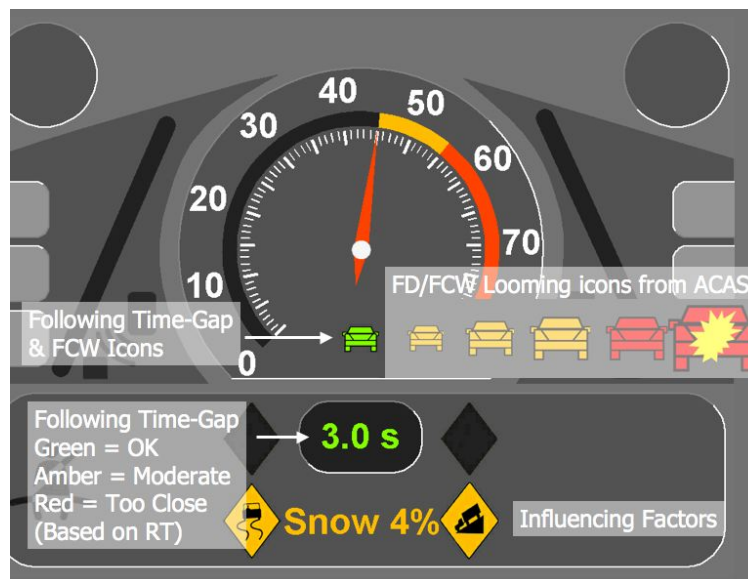

**Figure 5-2. OBMS Prototype Following Time-Gap Visual Feedback Design**

The color coding of the digital time-gap display (and corresponding vehicle icon) was based on two parameters. First, a minimum recommended following distance was computed based on

stopping distance assuming that the truck and followed vehicle would start braking at the same time. If the following time-gap was less than the minimum plus 0.5 s for the truck driver reaction time, then flashing red (at 2 Hz) was used for the text color and icon. Solid red was used for less than 1.0 s of reaction time, amber for less than 2 seconds, and green for greater than 2 seconds. When the collision warning system sounded, the red icon with the yellow crash was used flashing at approximately 4 Hz.

### OBMS FOT Recommendations

The following time-gap feedback display and algorithm may require some fine tuning with actual truck drivers, especially in field conditions with heavy traffic to assure that the display and algorithms meet their needs under non-free flow conditions. The Eaton Vorad EVT-300 uses the most simplistic forward collision warning algorithm and produces a greater number for false alarms than might be desired; however, it is the most common system found in trucks so drivers may be more likely to be familiar with and tolerant of the system. Furthermore, since the following distance feedback algorithm being used in the prototype's visual display is more advanced than the one being used by the Eaton Vorad, there is the potential for a mismatch between the auditory and visual warnings. This potential mismatch may need to be addressed if drivers notice it or become confused by it.

## **5.1.4 Monitoring Attention and Fatigue**

### Research Summary and Design Comparison

Inattention and fatigue generally result in two types of crashes, rear-end crashes and crashes resulting from a lane-departure. Since a forward collision warning system (discussed earlier) is the typical countermeasure associated with a rear-end crash, this section will only focus on lane departure warning systems and direct or indirect detection of inattention and fatigue.

Direct detection of inattention and fatigue requires driver eye, head, and/or face tracking. Until recently, the only COTS off-head fatigue detection monitor was produced by Attention

Technologies (<http://www.attentiontechnology.com/>), consisting of a single infrared camera used for pupil monitoring and a driver display unit. While the system has a novel interface, providing both visual feedback of how far the vehicle traveled when you last closed your eyes and an audible alarm, the system only performs adequately at night. A new system, the Seeing Machines DSS-R or driver state sensor (<http://www.seeingmachines.com/>), is soon to be released in 2007. While also a single camera system, the product provides for both daytime and nighttime operation and for limited attention (eyes-off-the-road) monitoring.

For Lane Departure Warning (LDW) systems, there are two COTS systems currently being manufactured, the SafeTRAC by Assistware (<http://www.assistware.com/>) and the Mobile Eye (<http://mobileye-vision.com/>). It should be noted that Iteris Inc. (<http://www.iteris.com/>) also supplies its AutoVue custom lane departure warning systems to vehicle manufacturers; however, they do not have a COTS aftermarket system. While the amount of research on lane departure warning systems has been considerable, the most recent and comprehensive study is the currently ongoing Road Departure Warning System (RDWS) and Curve Speed Warning (CSW) FOT being conducted at UMTRI which used the Assistware lane tracking sensor but their own custom DVI. Table 5-3 describes the lane departure DVI designs used by the various COTS systems and FOTs.

**Table 5-3. Lane Departure Driver Feedback Designs.**

<b>COTS &amp; FOT LDW Systems</b>	<b>Visual Warnings</b>	<b>Auditory Warnings</b>	<b>Haptic Warnings</b>	<b>Fatigue Detection</b>
Assistware SafeTRAC	3-line graphic showing position within the lane	Non-Directional - Single beep for lane change without turn signal use - Double beep for imminent LDW	None	Fatigue Number (0-100)
Mobile Eye	Green flashing left or right lane lines drawn in perspective	Directional - Rumble strip	None	None
Iteris AutoVue	Custom built	Directional - Rumble strip	Custom built	None
UMTRI RDWS FOT (using SafeTRAC with a custom interface)	2-Stage Icon - Yellow-Caution - Red-Imminent	Directional - Buzz/Tone for second stage imminent LDW	Directional - Seat vibration on first stage cautionary alert	None

### OBMS Prototype Feedback Design

The OBMS prototype used the Assistware SafeTRAC system for lane departure warning and fatigue detection. As shown in Figure 5-3, the visual provided by the device itself was very simplistic, consisting of a single line text display showing the fatigue number and a graphical display of the current position within the lane. The display could also show simple messages such as “Get Rest” if the fatigue number dropped below a specified threshold. For lane departure warnings, the system relied on a non-directional beeps.



**Figure 5-3. COTS SafeTRAC Lane Departure Warning System DVI**

Compared to the other COTS LDW devices on the market, and the state-of-the-art being testing in the current LDW FOT, the SafeTRAC has, perhaps, an interface that that could be considered as less than minimally desired. To supplement the SafeTRAC’s COTS feedback, a visual indication of any detected lane departures was added to HHDD OBMS prototype display (Figure 5-4). If a lane departure was detected by the system, either the right or left lane line flashed red (at ~4 Hz) for the duration of the event.

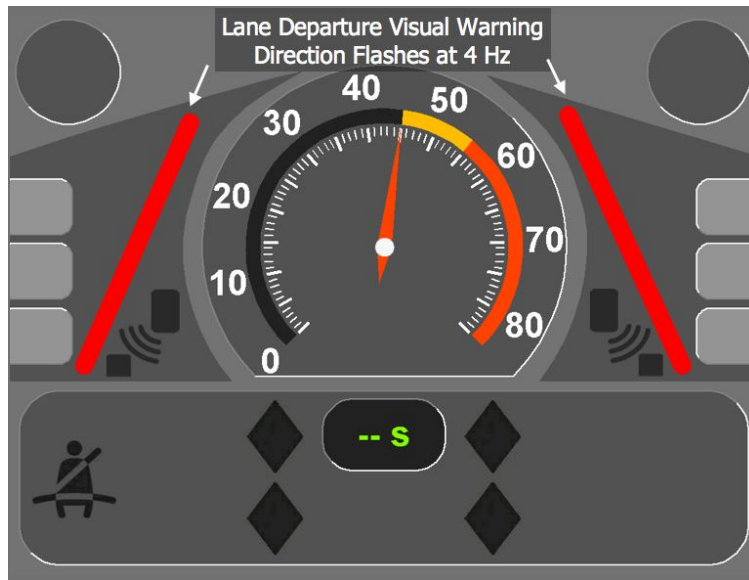

**Figure 5-4. OBMS Prototype Lane Departure Warning Visual Feedback Design**

One final element relating to fatigue monitoring that could be added to the prototype OBMS display is an Hours of Service (HOS) remaining countdown. To keep the display from becoming too distracting, it should probably only include the driving start time, and a countdown of hours remaining, at least until the last 30 to 90 minutes, when minutes remaining would be more appropriate. Alternatively, the HOS remaining might be hidden on the main display, and only appear in the last 30 to 90 minutes.

#### OBMS FOT Recommendations

In talks with potential trucking industry partners, it was mentioned that the COTS SafeTRAC device has been evaluated and dismissed by several trucking companies since the drivers found the system to be less than useful due to the fact that they could never understand what it was doing or telling them. These kinds of comments suggest that some effort should be spent to supplement the SafeTRAC's feedback and warning interface, and bring it up to par with the current thinking on LDW systems. At minimum, this would mean modifying the system to add directional audio tones (or rumble strips). Haptic feedback could also be considered depending on the recommendations of the UMTRI FOT as it nears completion.



It is also recommended that at least one sensor be added to the prototype to monitor fatigue and attention directly, such as the Seeing Machines DSS-R. The device was not available during the construction of the initial OBMS prototype, but will be explored during the FOT. A model for driver feedback with the device would follow the same lines as the feedback provided by the Attention Technologies fatigue monitor. Feedback and warnings for high PERCLOS, lengthy eye closures, and excessive eyes-off-the-road glances should be developed.

Finally, some of the finer details, such as how to display the HOS remaining, could be effectively displayed in multiple ways. The initial stages of the FOT should get some feedback from the drivers early on as what their preferences might be.

### **5.1.5 Monitoring Good Driving Safety Practice**

#### Research Summary and Design Comparison

Two topics fall into this category that have had some documented research. First, on the issue of seat belt use, the Transportation Research Board (2003) issued a comprehensive special report on safety belt technologies for passenger automobiles. In passenger cars, NHTSA regulates seat belt reminder design and is currently prohibited by law from requiring more than a visual display and auditory tone lasting 4 to 8 seconds upon vehicle start-up. However, NHTSA is not expressly prohibited from allowing enhanced seat belt warnings. From a survey of several late model vehicles from Ford and Honda, the typical enhanced seat belt warning provides a six second audible warning (and flashing seat belt icon) every 30 to 35 seconds once the vehicle's speed exceeds 10 to 15 mph. Such regulations do not exist with commercial trucks; however, this reported practice may lead to driver safety and could be considered.

A second issue covered in this section is turn signal use during lane changes. Although merely a footnote, most studies involving lane departure warning and side obstacle detection systems report that turn signal use during lane changes increased as a side effect of having these systems.

## OBMS Prototype Feedback Design

Four monitored parameters were classified into the category of general good driving safety practice: seat belt use, lane change signal use, mirror adjustment, and side collision avoidance or blind spot warning. The side collision avoidance system used was the Eaton Vorad Blindspotter warning system that came factory installed in the truck. The display consisted of a set of two LEDs mounted inside the vehicle on the A-pillars near the side mirrors. The bottom LED was continuously yellow indicating that no object was detected. When an object was detected the top LED illuminated red. To supplement the factory display, side object awareness icons were added to the prototype HHDD display (Figure 5-5) since there has been some research to suggest that this location would be ideal as a supplementary display for the side obstacle detection icons (Olsen, 2004). These icons would illuminate if the driver put on the turn signal when an object was detected in a blind spot (accompanied by an audible beep provided by the factory system installation).

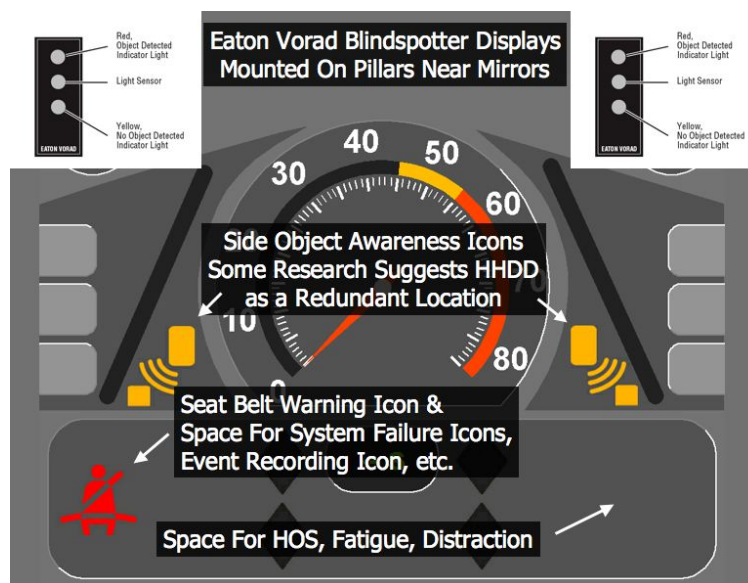

**Figure 5-5. OBMS Prototype Visual Feedback Design for Seat Belt and Side Obstacles**

The seat belt monitoring system used the standard seat belt warning icon displayed on the OBMS prototype HHDD (as access to the factory seat belt warning system was unavailable). The system functioned in the same manner as other automotive enhanced seat belt warning systems,

flashing the icon in accompaniment with an auditory tone for 6 seconds every 30 seconds when the vehicle exceeds 15 mph.

Turn signal use during lane changes was not displayed visually in real-time, but lane changes made without turn signal use would cause the SafeTRAC to emit a single beep. Feedback for monitoring mirror adjustment is proposed as a simple “check mirror adjustment icon” that comes on next to the seat belt icon whenever a new driver enters the vehicle and inserts his driver ID card. The icon would be turn off as soon as the driver adjusted the right power mirror.

### OBMS FOT Recommendations

Other convenience and reporting features may need to be added based on driver feedback. As an example, some companies may be interested in fuel economy, maximum engine RPMs, or other engine parameters which could easily be incorporated into the DVI.

#### **5.1.6 Off-Line Feedback and Reporting**

While the bulk of the interface design has focused on the real-time, in-cab feedback for the driver, off-line feedback and summary reporting will still need to play an integral role in any successful driver monitoring and feedback program. The purpose of the off-line feedback and summary reporting is two-fold. First, the off-line feedback supplements the real-time feedback as there are some measures of driving performance that may only be useful when summarized over time or compared across drivers. Second, the summary reporting needs to convey the results of the driver monitoring to management, allowing for the identification of which drivers need improvement in which areas.

Two monitoring parameters that will primarily use off-line feedback include hard braking and hard steering incidents. For either parameter, a single incident alone may not be significant, but a pattern of repeated incidents might indicate an underlying problem such as aggressive driving or excessive inattention.

The frequency of off-line feedback summary and reporting could vary from weekly to monthly, although some measures, such as hard braking incidents, may require averages over a longer time period to produce a useful and reliable metric. Some of the parameters may require additional filtering or comparing across drivers to produce a useful and reliable metric. As an example, the Eaton Vorad EVT-300 produces numerous false alarms in real-world driving conditions, so simply looking at the number of forward collision warning alerts would probably not provide any useful information about how safe a particular driver was without comparing that driver to others.

As discussed earlier and as laid out in Sherry (2001), the behavior-based safety approach to onboard driver-monitoring requires four steps with this report focusing primarily on steps one and two:

1. Identify behaviors which may be precursors to increased crash rates.
2. Determine cost-effective ways to monitor safe and unsafe behaviors.
3. Determine the best way to provide the driver with feedback which rewards safe behavior and discourages unsafe behavior.
4. Establish management and driver acceptance to the program.

The off-line feedback and summary reporting design feeds into steps three and four and should be designed with the input of an actual truck carrier (FOT partner) as part of a comprehensive safety monitoring and feedback program. There are numerous issues in the design of such a program that would need to be addressed, including the format of the report, who receives or has access to the reports, and how the reports will be used.

#### **5.1.7 Incident Recording and Review**

Related to the off-line feedback and summary reporting is the issue of how to deal with recorded incidents. While the system will record, save, and sort incidents (such as speeding, hard braking, hard steering, and seat belt nonuse), a program with the carrier will need to be established to review these incidents. Such a program might involve driver self-review of incidents,

management or safety officer review of incidents, or a combination of both. The details of the program will depend heavily on the corporate culture of the carrier. Such an incident review program will require software to download the saved incidents from the trucks and transfer them to a centralized server, categorize the incidents, and finally a tool to select and playback the video and associated vehicle data.

## **References (Section 5.0)**

Alkim, T. (2006). The Assisted Driver Interim Results. Presentation at the International Task Force on Vehicle-Highway Automation Meeting (London). Den Haag, Netherlands: Dutch Ministry of Transport, Public Works, and Water Management.

Brookhuis, K., and de Waard, D. (1999). Limiting speed, towards an intelligent speed adapter (ISA). *Transportation Research F*, 2, 81-90.

Ervin, R., Sayer, J., LeBlanc, D., Bogard, S., Mefford, M., Hagan, M., Bareket, Z., and Winkler, C. (2005). Automotive Collision Avoidance System FOT Methodology and Results Volume 1 (Technical Report UMTRI-2005-7-1). Ann Arbor, MI: The University of Michigan Transportation Research Institute.

Ervin, R., Sayer, J., LeBlanc, D., Bogard, S., Mefford, M., Hagan, M., Bareket, Z., and Winkler, C. (2005). Automotive Collision Avoidance System FOT Methodology and Results Volume 2: Appendices (Technical Report UMTRI-2005-7-1). Ann Arbor, MI: The University of Michigan Transportation Research Institute.

Ervin, R., Sayer, J., LeBlanc, D., Bogard, S., Mefford, M., Hagan, M., Bareket, Z., and Winkler, C. (2005). Automotive Collision Avoidance System FOT Methodology and Results (Technical Report UMTRI-2005-7-2). Ann Arbor, MI: The University of Michigan Transportation Research Institute.

Kochhar, D. and Tijerina, L. (2006). Comprehension of Haptic Seat Displays for Integrated

- Driver Warning Systems. Proceedings of the Human Factors and Ergonomics Society 50<sup>th</sup> Annual Meeting. Santa Monica, CA: 2395-2399.
- Neurauter, L. (2004). Multidimensional warnings: Determining and Appropriate Stimulus for a Curve-Warning Device (Maser's Thesis). Blacksburg, VA: Virginia Polytechnic Institute and State University.
- Olsen, E. (2004). Lane Change Warning Design Guidelines. Proceedings of the Human Factors and Ergonomics Society 48<sup>th</sup> Annual Meeting. Santa Monica, CA.
- Sherry, P. (2001). *In-Vehicle Monitoring Technologies: Review of Current Use and Potential Enhancement Through Behaviorally Based Safety Processes* (Report Submitted to the American Trucking Association Foundation). Denver, CO: The University of Denver.
- Shinar, D. and Schechtman, E. (2001). Headway feedback improves inter-vehicular distance: a field study. *Human Factors*, 44(3), 474-481.
- Transportation Research Board (2003). Buckling Up: Technologies to Increase Seat Belt Use (Special Report 278). Washington, D.C.: National Academies of Science.
- Várhelyi, A. and Mäkinen, T. (2001). The effects of in-car speed limiters: field studies. *Transportation Research C*, 9, 191-211.
- Várhelyi, A., Hjalmdahl, M., Hydén, C., and Draskóczy, M. (2004). Effects of an active accelerator pedal on the driver behaviour and traffic safety after long-term use in urban areas. *Accident Analysis and Prevention*, 36, 729-737.
- Young, K., Regan, M., Triggs, T., Tomasevic, N., Stephan, K., and Mitsopoulos, E. (2006 Manuscript). Impact on Car Driving Performance of a Following Distance Warning System: Findings from the Australian TAC SafeCar Project. (Manuscript submitted for publication in the *Journal of Intelligent Transportation Systems*).

## 6 FOT PLANNING

An activity planned and conducted during this study was to leverage the expert interviews, research conducted – and, we hoped, a carrier stakeholder – into a FOT plan, for further development and a research-focused initial implementation of an OBMS system into a field trial. The purpose of this activity was to set the foundation for a follow-on effort to essentially propagate and test OBMS ideas in a larger, real-world setting.

As it turns out, the initial carrier contact, who enthusiastically participated with the OBMS research and prototype development team, was less forthcoming in co-developing a FOT plan. Hence, this FOT plan was largely developed by the research team, bereft of the all-important operational and pragmatic knowledge base of a carrier. This was redressed quite well at the end of the project, as a different carrier was quite engaged and committed at that stage; however, the FOT developed and planned will have to undergo revision to adjust to this particular carrier's needs, knowledge and operational philosophy.

The FOT development and testing is envisioned to be conducted using a Systems Engineering approach and process following the guidelines of the Systems Engineering Guidebook online at <http://www.fhwa.dot.gov/cadiv/segb>, and will use the Vee Technical Model diagramed in Figure 6-1. It is envisioned that the project will span 15 trucks and will take place over a period of 48 months commencing near the beginning of FY08. Within this time period the formal FOT is expected to be conducted over 18 month period consisting of two parts: *a pilot test* and the *final FOT observations*. It is expected that in the end, an understanding of how an OBMS system would be integrated into carrier operations and be accepted by stakeholders (e.g., carrier, driver, safety community to include State and Federal governments) will be understood, as well as the value. This will allow carriers and other potential users and stakeholders to determine the effectiveness vis-à-vis costs.

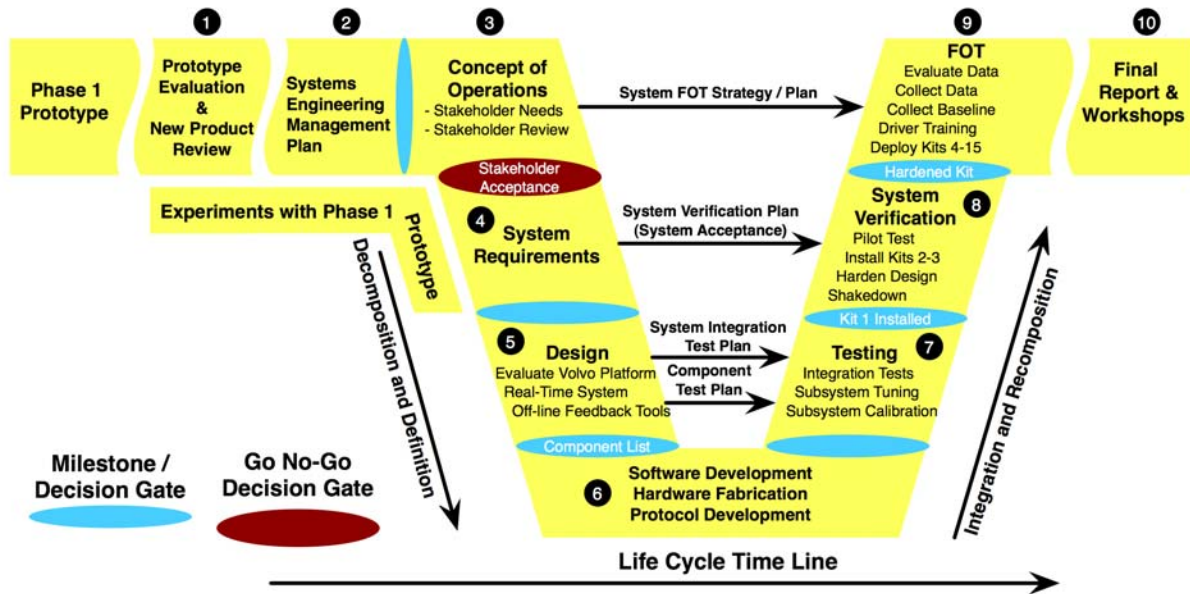

**Figure 6-1. System Engineering Vee Diagram Illustrating Sequence of 10 Tasks to Complete FOT**

The FOT plan developed prior to this end-of-project interaction, is an interesting layout of initial ideas for such a test. It is worth noting that one very important and well-developed aspect of the FOT plan is driver feedback, which is discussed to considerable extent in Section 5.0. Part of the development of Section 5.0 stemmed from considerations and feedback, particularly from FMCSA, on what attributes should be monitored in real-time and post facto by the carriers. This discussion and consideration of the monitored parameters is encapsulated in Table 6-1 below.



**Table 6-1. Attributes to be Monitored and Associated Feedback Methods**

Core Behavioral Categories	Potential Behaviors/Parameters To be Monitored	Required Sensors or Subsystems	Potential Driver Feedback	
			Real-Time	Off-Line (Delayed)
<b>1. Speed Selection</b>	Speed vs. - Speed Limit - Traffic Flow - Curve Speed - Road Surface - Grade	Vehicle Jbus Access GPS Database of Speed Limits Road Surface/Weather Radar or Lidar Accelerometer	Visual feedback of recommended and maximum speed limits	Summary metrics such as the time spent over the recommended and maximum speed limits
<b>2. Following Behavior</b>	Following Distance Forward Collision Warnings Driver response to Cut-ins	Forward Collision Warning System (FCW) Radar or Lidar Video Recording	Visual feedback of following time-gap shown  Auditory alerts for following too close and approaching too fast	Summary of time spent following too close, # of warning incidents, video review of warning incidents
<b>3. Attention (or Inattention)</b>	Road/Lane Departures Hard Braking Events Hard Steering Events Eye-Off-The-Road	Road Departure Warning System (RDWS or LDWS) Accelerometer Steering Angle Steering Gyro Video Recording Eye/Face Tracking	Visual and auditory alerts of lane departures or eyes-off-the-road for too long	Summary metrics such as the frequency of lane departures, hard braking, and hard steering incidents
<b>4. Fatigue</b>	Road/Lane Departures Lane Position Keeping Hard Braking Events Hard Steering Events Eye Closure (PERCLOS) Hours of Service (HOS) Compliance	RDWS / LDWS Eye Tracking Accelerometer Steering Angle Steering Gyro Video Recording EOBR (Electronic On-Board Recorder for HOS)	Visual and auditory alerts of lane departures, lane weaving, eye closure, and HOS compliance	Summary metrics such as the frequency of lane departures, hard braking, hard steering incidents, and HOS compliance
<b>5. General Safety</b>	Safety Belt Use Lane Change Turn Signal Use Lane Change Blind Spot Check Proper Mirror Adjustment Fuel Economy Engine Overspeed (RPMs) Acceleration Deceleration (Downshifting) Gear selection on grades	Safety Belt Monitor Video Recording RDWS / LDWS Eye/Face Tracking Accelerometer Vehicle Jbus Access Misc. Wire Taps	Visual and auditory alerts if safety belt is not use  Visual feedback on other parameters	Summary metrics such as time spent using the safety belt and the other listed parameters

## 7 SUMMARY AND CONCLUSIONS

The OBMS prototype development was based upon prior research which points to progression of four steps toward implementing an onboard driver-monitoring behavior-based safety approach:

1. Identify behaviors which may be precursors to increased crash rates.
2. Determine cost-effective ways to monitor safe and unsafe behaviors.
3. Determine the best way to provide the driver with feedback which rewards safe behavior and discourages unsafe behavior.
4. Establish management and driver acceptance to the program.

This project did not complete, nor was it designed to complete, the four steps, each in their entirety; rather, the project did a thorough review – and where possible, expert interviews with a carrier – to implement a prototype that addressed steps 1 – 3. Step 4 would require strong carrier participation, and ideally, a FOT, something also covered in this project and described in Section 6.0.

The project was tailored to and performed with the principles of Systems Engineering. The nomograph shown in Figure 7.1 illustrates the project tasks, conducted along the left side then down the vertex of the “Vee Diagram”, then up through the horizontal dashed line, low speed testing in the environs of the PATH facility of the Richmond Field Station, to include public roads outside the premises.

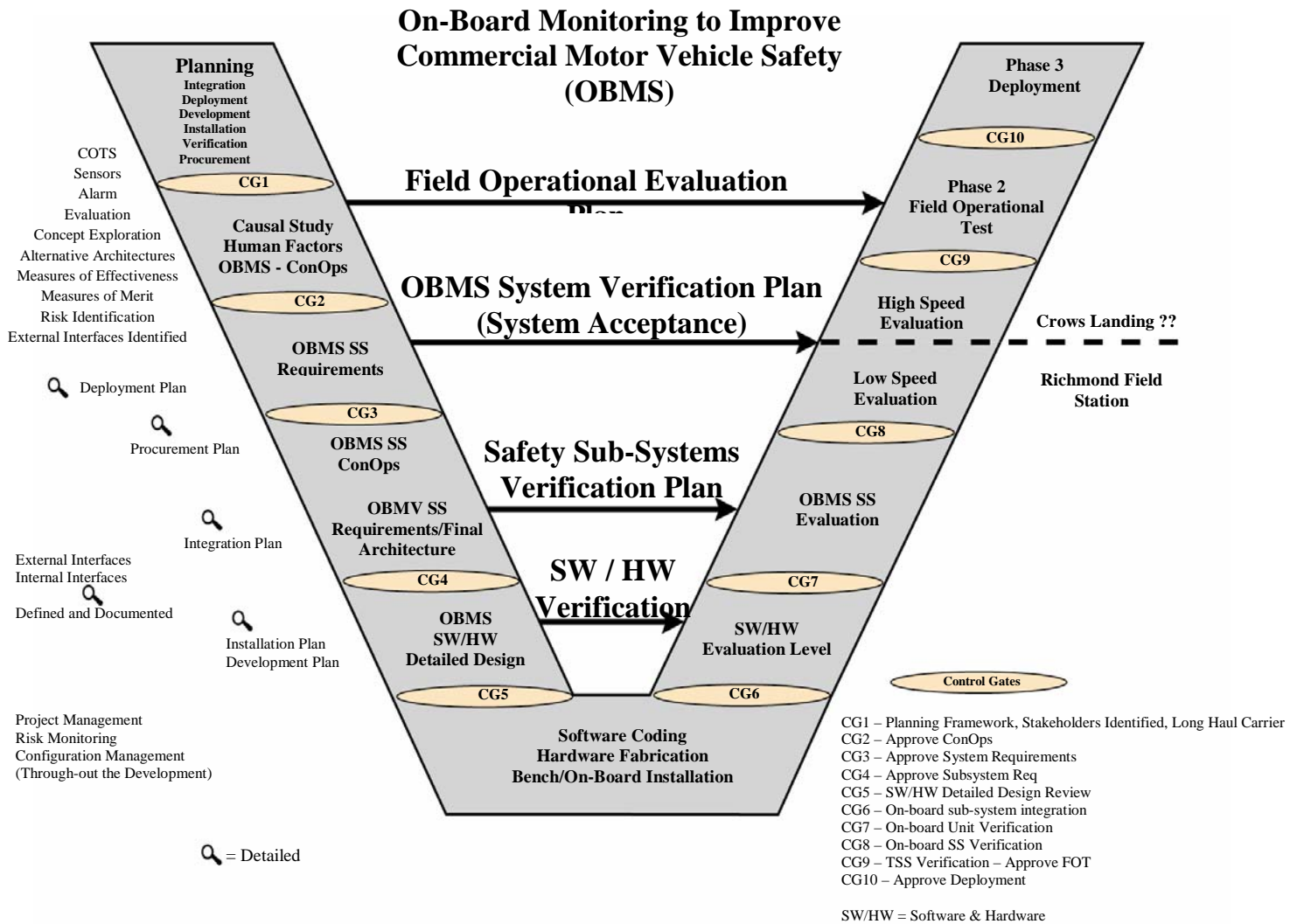

**Figure 7-1. Project Vee Diagram**

The resulting hardware and software that constitute the prototype OBMS is described in block diagram form in Figure 7-2 (and more fully, in Sections 3.0 and 4.0). Suffice it to say that monitored driver behaviors are clustered into five monitoring categories or behaviors:

1. Speed Selection
2. Following Behavior
3. Attention (or Inattention)
4. Fatigue
5. General Safety

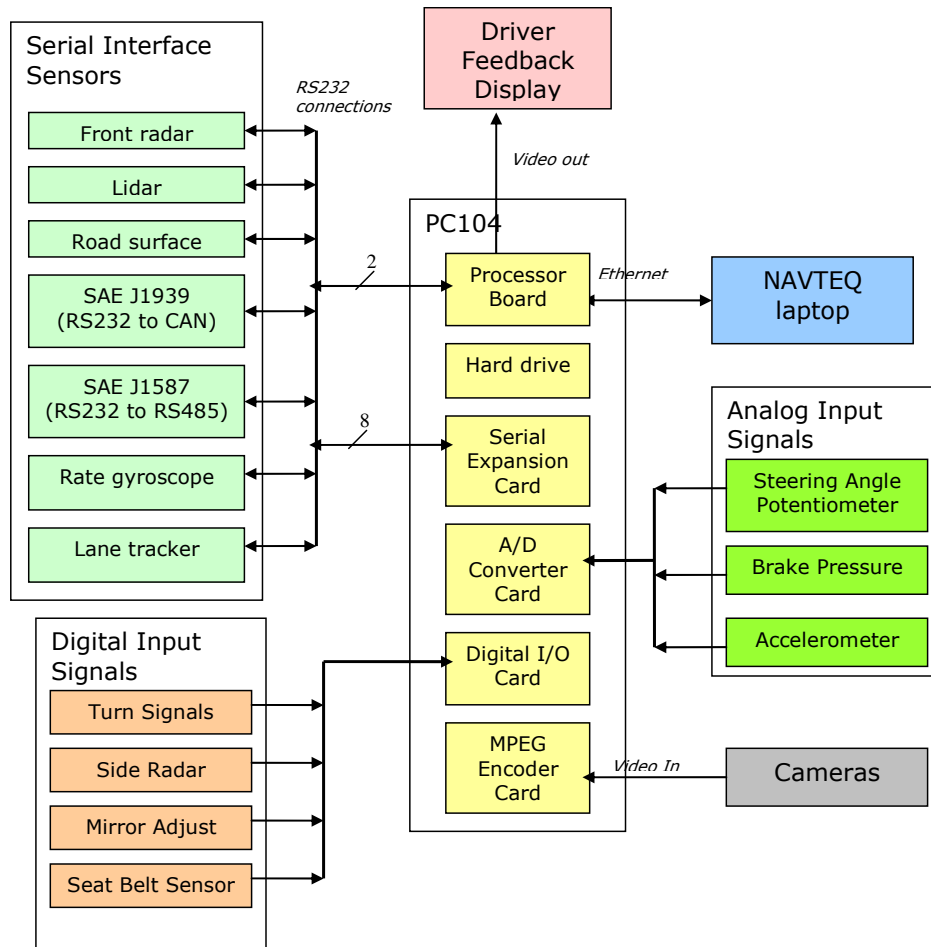

**Figure 7-1. Block Diagram of OBMS Prototype PC104 and Sensor Interfaces**

The resultant suite, with functions, monitored elements and feedback attributes is given in Table 7-2. To underscore, this prototype suite is unique in that it is aimed squarely at safety and not necessarily toward other fleet operational goals. However, the overall philosophy is that it is an operational imperative to reduce crashes and therefore fatalities, injuries and property damage

due to CMV drivers. The main means to lower the amount of CMV driver errors is to improve driver performance through onboard monitoring systems, coupled with appropriate feedback to the driver. This project therefore served as a foundation to illustrate how to design and build an onboard monitoring that may provide the best, lasting mechanism to encourage good driving behavior by recognizing and correcting self-induced hazardous driving situations.

**Table 7-2. Summary of OBMS Suite: Functions, Monitored Elements, Feedback**

Core Behavioral Categories	Potential Behaviors/Parameters to be Monitored	Required Sensors or Subsystems	Potential Driver Feedback	
			Real-Time	Off-Line (Delayed)
<b>1. Speed Selection</b>	Speed vs. - Speed Limit - Traffic Flow - Curve Speed - Road Surface - Grade	Vehicle Jbus Access GPS Database of Speed Limits Road Surface/Weather Radar or Lidar Accelerometer	Visual feedback of recommended and maximum speed limits	Summary metrics such as the time spent over the recommended and maximum speed limits
<b>2. Following Behavior</b>	Following Distance Forward Collision Warnings Driver response to Cut-ins	Forward Collision Warning (FCW) Radar or Lidar Video Recording	Visual feedback of following time-gap shown  Auditory alerts for following too close and approaching too fast	Summary of time spent following too close, # of warning incidents, video review of warning incidents
<b>3. Attention (or Inattention)</b>	Road/Lane Departures Hard Braking Events Hard Steering Events Eye-Off-The-Road	Road Departure Warning System (RDWS or LDWS) Accelerometer Steering Gyro Video Recording Eye/Face Tracking	Visual and auditory alerts of lane departures or eyes-off-the-road for too long	Summary metrics such as the frequency of lane departures, hard braking, and hard steering incidents
<b>4. Fatigue</b>	Road/Lane Departures Lane Position Keeping Hard Braking Events Hard Steering Events Eye Closure (PERCLOS) Hours of Service (HOS) Compliance	RDWS / LDWS Eye Tracking Accelerometer Steering Angle Steering Gyro Video Recording EOBR (Electronic On-Board Recorder for HOS)	Visual and auditory alerts of lane departures, lane weaving, eye closure, and HOS compliance	Summary metrics such as the frequency of lane departures, hard braking, hard steering incidents, and HOS compliance
<b>5. General Safety</b>	Safety Belt Use Lane Change Turn Signal Use Lane Change Blind Spot Check Proper Mirror Adjustment Fuel Economy Engine Overspeed (RPMs) Acceleration Deceleration (Downshifting) Gear selection on grades	Safety Belt Monitor Video Recording RDWS / LDWS Eye/Face Tracking Accelerometer Vehicle Jbus Access Misc. Wire Taps	Visual and auditory alerts if safety belt is not use  Visual feedback on other parameters	Summary metrics such as time spent using the safety belt and the other listed parameters

## Glossary of Acronyms, Abbreviations and Symbols

Caltrans:	California Department of Transportation
CAN:	Controller Area Network
CCIT:	California Center for Innovative Transportation, UC Berkeley
CMV:	Commercial Motor Vehicle
<b>COM</b> :	Designates a requirement that applies only to ultimate commercialization
COTS:	Commercial Off-The-Shelf (commercially available product)
DRI:	Caltrans' Division of Research and Innovation
DSP:	Digital Sound Processor
EOBR:	Electronic On-Board Recorder
FHWA:	Federal Highway Administration
FMCSA:	Federal Motor Carrier Safety Administration
FOT:	FOT
<b>FOT</b> :	Designates a requirement that applies to the FOT but not to the prototype
GIS:	Geographical Information System
GPS:	Geographical Positioning System
GUI:	Graphical User Interface
HOS:	Hours Of Service
LCD:	Liquid Crystal Display
LDWS:	Lane Departure Warning Systems
MTBF:	Mean Time Between Failures
MVMT:	Million Vehicle Miles Traveled
NEMA:	National Electrical Manufacturers Association

NTSC: National Television Standards Committee

OBMS: On-Board Monitoring System

OBP: On-Board Processor

OEM: Original Engineering Manufacturer

PATH: Partners for Advanced Transit and Highways, UC Berkeley

RODS: Records Of Duty Status

RPM: Revolutions Per Minute

SAE: Society of Automotive Engineers

TBD: To Be Determined

TPM: Technical Performance Measure

VHT: Vehicle-Hours Traveled

VMT: Vehicle-Miles Traveled



## **APPENDIX A: SYSTEMS ENGINEERING PROCESS AND CHRONOLOGY**

This section describes the systems engineering efforts undertaken as a part of the OBMS project. Emphasis is placed on some of the most important project processes identified in systems engineering, including integration, configuration management, verification, and risk management. These terms are defined in relevant subsections.

**It is noted that the application of the systems engineering Vee Diagram shown in Figure A-1 dictates a research-development-prototype cycle with concomitant systems documentation. Because the resources to do this were lean, some of the documentation was sparse; in other cases – particularly in the tradeoff basis for our downselection of OBMS components – the documentation is necessarily extensive. In this section, we will show examples of diagrams and tables project team members developed to track progress related to integration, configuration management, verification, and risk management processes in order to illustrate the tools and sequences used in this project and to provide in abstract form a foundation to understand the OBMS prototype. The Systems Engineering Management Plan (SEMP) and System Requirements documents are also provided to further demonstrate the project team’s work in the area of Systems Engineering. As such, the bulk of our OBMS documentation can be found in following sections, and in particular Section 2 (Concept Development) and Section 3 (OBMS Suite).**

### **A.1 Integration**

**In the language of Systems Engineering, integration is a term used to describe the combining of components or sub-systems to form a complete functional end product system. Hardware and software components must be identified or constructed, and connected to one another. Planning is essential, both before and during the development of the component sub-systems used. Unforeseen difficulties connecting component pieces of a project can yield old plans obsolete, and a dynamic approach is needed for integration.**

Integration was especially important for this project, as the project consisted of combining data from available on the truck serial buses, various Commercial Off-The COTS products and custom-built devices that were mounted on a truck, processing this data both on the truck itself and off-line, and providing feedback to truck drivers. Links had to be forged between the various sensors and an onboard computer, between the computer and driver interface devices, and between the computer and an off-line analysis module.

Figure A-1 provides a broad overview of the sub-systems that had to be integrated for this project. Arguably the most daunting challenge of this project was linking a comprehensive suite of COTS and custom-built sensors to a computer installed on the tractor. Different component sensors required different hardware connections. For instance, COTS lane tracker systems could be connected directly to the serial ports of a computer while cameras the project team purchased needed to be linked to MPEG encoder cards. Even ensuring that the onboard computer recognized the various computer cards attached to it was complex. Coordination discussions had to be held to determine which cards worked with which computer operating systems, and which operating systems could be installed on the onboard computer. Communications were crucial here, and weekly meetings were set up to check the progress of integration efforts and to plan future integration related tasks.

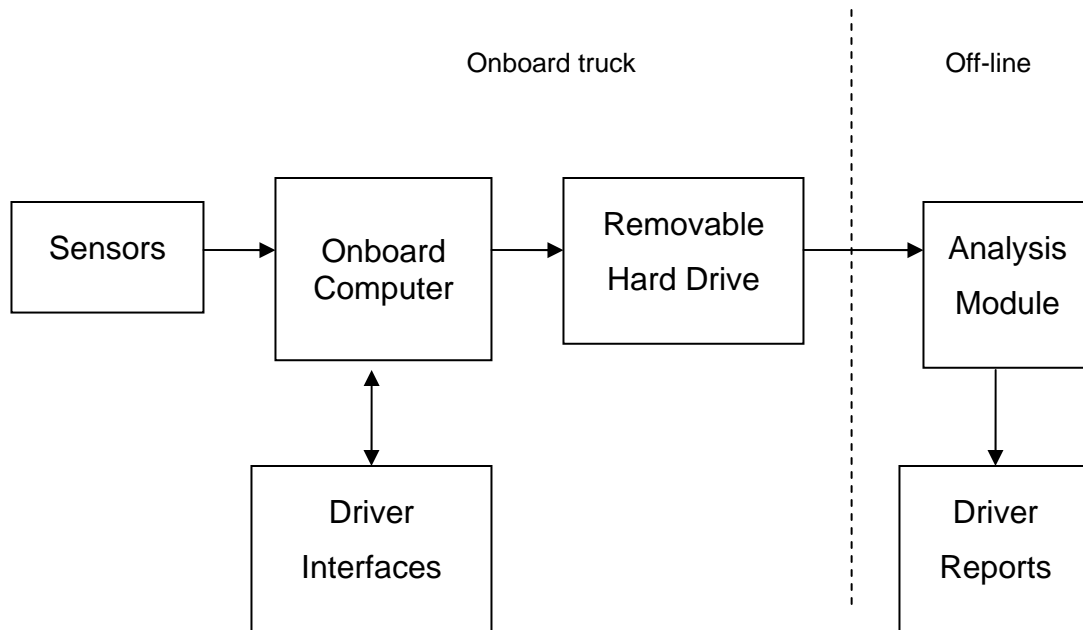

**Figure A-1. Top-level Overview of Components that were Integrated**

Figure A-2 depicts how a handful of sensors were connected to the onboard computer and removable hard drive used in this project. At the start of this project, a similar set of tentative hardware connections were drawn up. As the project proceeded it became apparent that certain sensors would not be used on the experiment test truck, possibly because the hardware connections could not be made or possibly because the functionality these sensors offered was deemed unnecessary. Plans had to be altered on-the-fly.

The integration process progresses along the Vee Diagram; however, the iterative, experimentally-oriented tradeoffs to complete the design and installation progressed to a series of weekly progress meetings, which were informed by very rough block diagrams like the one presented in Figure A-2 and spreadsheets containing information about the status of efforts to link various system components. Discussions were also held at these weekly meetings related to configuration management, verification, and risk management efforts.

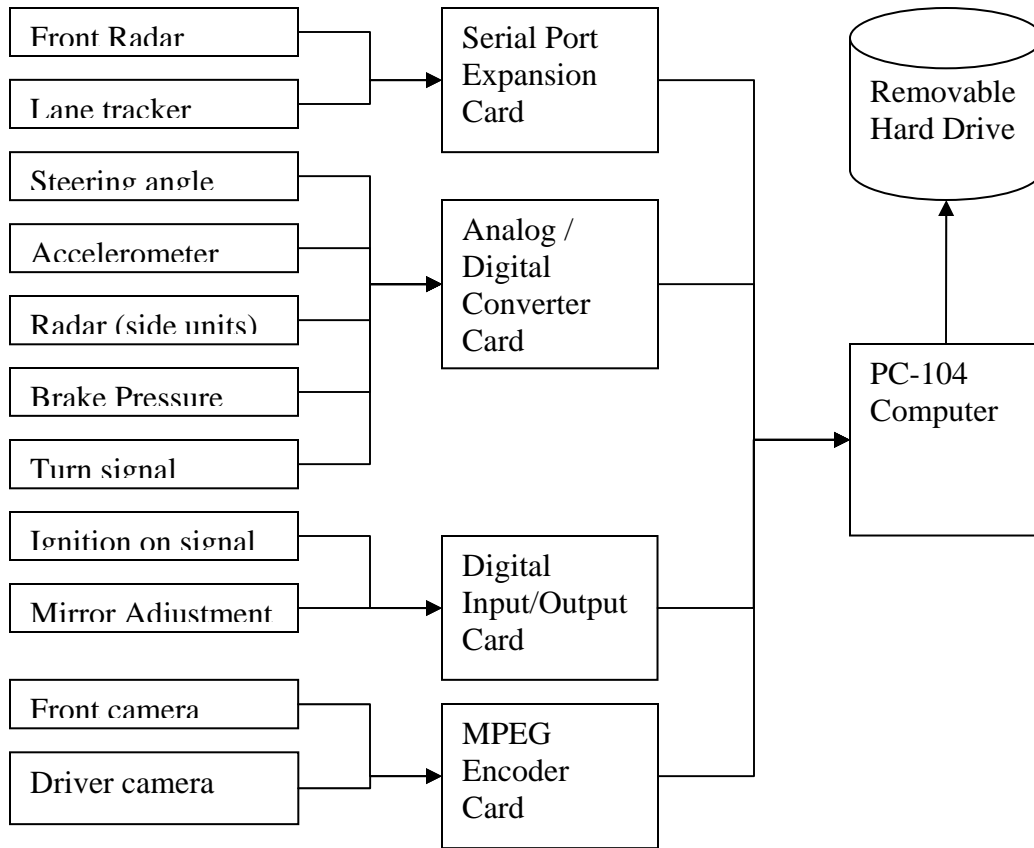

**Figure A-2. Overview of Hardware Integration Components/Topics**

## A.2 Configuration Management

Configuration management ensures that project documentation is consistent with the characteristics of the system under development. Like integration, configuration management is a process that must be ongoing throughout the life span of a project. As changes are made to the system, documents must change as well.

For this project, as decisions were made about which sensors could and would be used on the test truck, the data that would be available also changed. Software had to adapt to reflect changing information. Figure A-3 shows the final state of connections made by software, using sensor data to track items of interest for potentially generating warnings that require communicating with a driver interface device or generating a driver report. So, the suite of sensors generating

data was changing, as was the software monitoring this data, as were the feedback mechanisms through which the system communicated with the driver. This constant change required a concentrated effort in the area of configuration management.

Evidence of the project team's efforts in the area of configuration management can be seen in the changing Systems Engineering Management Plan (SEMP) associated with this project. There was not always time to document decisions made and changing plans. However, the project team made sure to update the SEMP so that it reflected the evolving project. The final version of the SEMP is included in Appendix B.

### **A.3 Verification**

Verification is the process by which the project team ensures that the system, as it is being built, meets the requirements. Appendix B contains the System Requirements Document developed by the project team, stemming from the ConOps (ConOps). This document was referred to time and again during the verification process. As was the case for the other processes identified above, much of the project team's efforts in verification centered on weekly meetings. Below is a list extracted from document related to verification efforts, with each of the "test item" columns consisting of a verification task.

- Radar calibration: long/lat distance; long/lat speed
- Lidar calibration: long/lat distance; long/lat speed
- IMU calibration: roll and yaw rate; lat accelerometer examination
- Tilt sensor for road grade

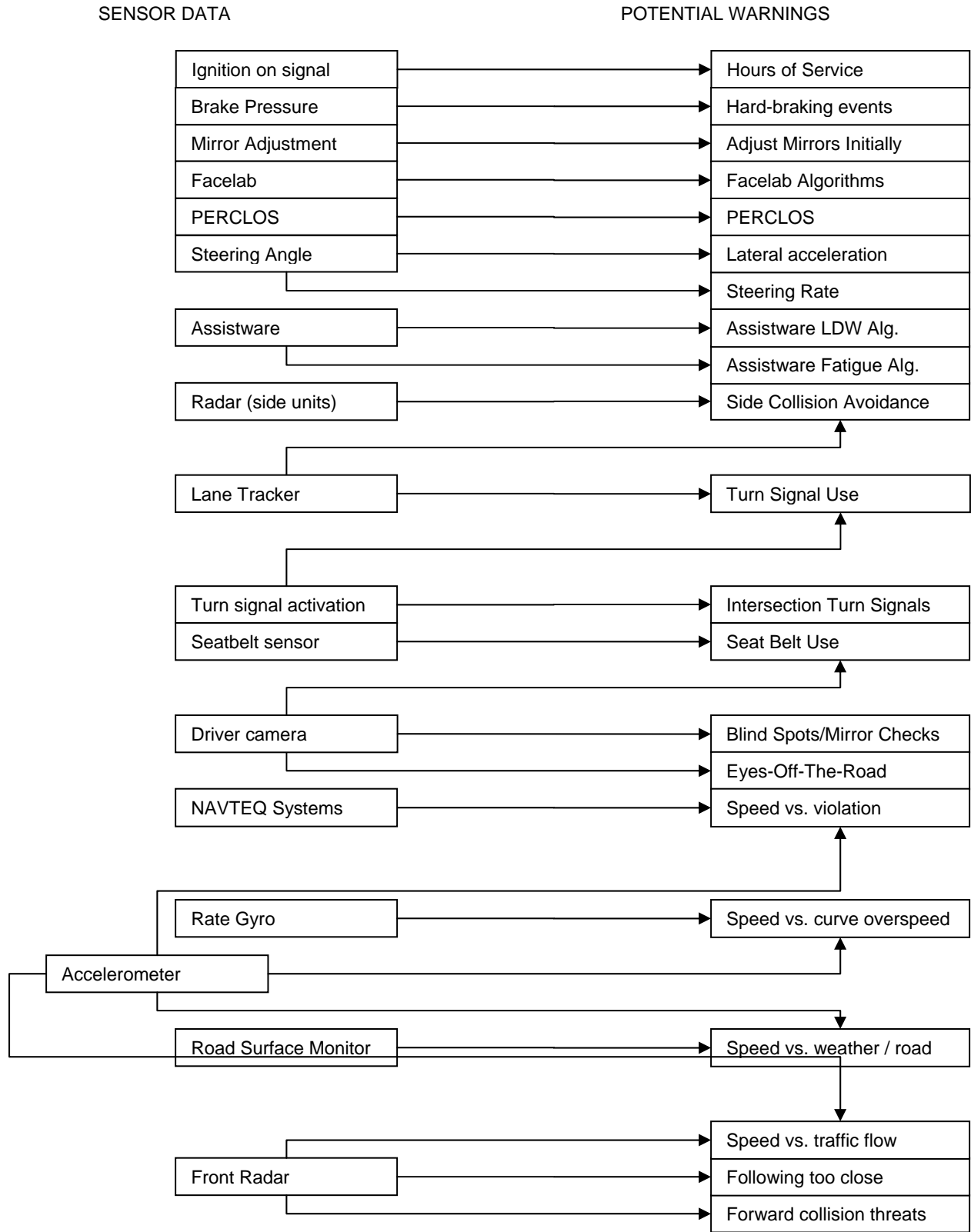

**Figure A-3. Functional Relationships between Sensor Data and Monitoring System**

- Road surface detection sensor
- NAVTEQ System: road curvature forecasting; GPS
- Integrate with feedback to the driver: following too close in normal weather and tilt sensor for road grade; overspeed in normal weather based on NAVTEG information about speed limit
- roll stability warning in normal weather
- roll stability warning in normal weather: on the curve
- roll stability warning in normal weather: begin to roll
- multiple target tracking
- following too close with weather factor and road grade incorporated

#### **A.4 Risk Management**

Risk management as a term is fairly self-explanatory. The goal of the risk management process in systems engineering is to recognize, plan for, and mitigate the impacts of risk during project development. Risk management is closely related to verification and integration. Major risks often have to do with the prospect of sub-systems failing to be integrated into a larger system, or failing tests run as a part of verification efforts. The risk management plan is provided with in the SEMP given in Appendix B.

## **APPENDIX B: SYSTEMS ENGINEERING MANAGEMENT PLAN**

### *Foreword*

This document outlines the System Engineering Management Plan (SEMP) for the OBMS PATH project. The Onboard Monitoring and reporting for commercial motor Vehicle Safety (OBMS) project starts as a research effort that will define the concept of an integrated safety monitoring system and turn it into a prototype. This will be followed closely by a FOT for which a plan will be specified during the research phase. The SEMF spells out system engineering process that will be applied as well as the project plan.

### B.1 Introduction

#### *B.1.1 Project summary*

The University of California Partners for Advanced Transit and Highways (PATH) and the California Center for Innovative Transportation (CCIT), both part of the Institute of Transportation Studies (ITS), are collaborating on this project to improve truck safety via onboard monitoring and reporting of variables that may precede crashes. The project is funded by the Federal Motor Carrier Safety Administration (FMCSA) through the California Department of Transportation (Caltrans). Both are considered project stakeholders.

If the prototype can demonstrate a significant potential to reduce truck accidents, the following step will be an attempt to turn the prototype into a commercially available product. One of the reasons of CCIT's involvement is to prepare this deployment stage.

#### *B.1.2 Document scope*

The System Engineering Management Plan (SEMP) describes the system engineering approach applicable to the project and presents the work plan. The SEMF is intended as a project roadmap that the project team and the project sponsor can refer to. It spells out what the project team will do and how it will accomplish it.



The document consists of two main sections, numbered 3 and 4. The first one describes the system engineering process itself in the context of this project. In particular, it shows how the environment and the constraints surrounding this project have shaped the planning of the workflow. The first section also presents each engineering discipline applicable to the project, and how the activities of these disciplines fit into the development process as a whole. The engineering specialties are the human factors, the hardware engineering, the software engineering, the data intelligence and the experiment design, systems engineering and deployment team.

The second part of this document is the overall project plan. That section includes the scope of work, the schedule, the deliverables, the project resources and the project management structure.

### *B.1.3 Applicable documents*

- California PATH, Statement of Work, OBMS – June 2005.
- California PATH, Kick-off meeting slide show, OBMS – June 2005

## B.2 System engineering process

### *B.2.1 Process intent and overview*

This project involves a multi-disciplinary team and a commercial partner yet to be determined. Its main deliverable will be a functioning prototype of an onboard monitoring system that processes inputs from various truck sensors and outputs safety metrics and warnings that are fed back to the drivers.

Because the prototype will be a complete system with hardware and software components, built for an operational environment with which it will interact tightly, it is appropriate to use a system engineering framework. The system engineering process intends to insure that the research product will be the result of a concerted effort to derive design and development from well-defined requirements, and to harmoniously integrate the different engineering disciplines.

The ultimate goal of this project is to turn the prototype to the industry so that truck carriers can benefit from enhanced safety features that could reduce the number of crashes and fatalities.

System engineering will enable the transition from research to industry by forcing a rigorous and well-documented development process from the early stages. If a deployed commercial system is considered the ultimate outcome of the OBMS research, then this project is the first iteration in a more global product development process.

While the expectation that the project delivers a functioning system underlines the needs for a system engineering process, some adjustments had to be made. First of all, the project is considered research and its outcome is a prototype. This means that the risks and uncertainties are usually higher than at the product development stages. Second, the project timing happens to be tight given the complexity of the task at hand. These two observations influenced the system engineering process presented in the next subsections.

### *B.2.2 Product development steps*

This project uses the traditional “Vee” diagram to define cascading stages in the development process. While this diagram and its specific representation in Caltrans’ guidelines for ITS system engineering were used as a base line, simplifications were made based on the nature of the project.

As already mentioned, this phase intends to develop a prototype and not the finished product. Moreover, the research aspect entails an exploratory component that is not always compatible with the stiffness of the system engineering development process.

This led the project team to consider what in the cascading process was really of importance to the ultimate success of the research. The research will be successful if 1) the prototype demonstrates some potential safety benefits and if, as previously stated, 2) it can be handed off after the Phase II FOT to the industry for widespread deployment. The system engineering process has only limited ability to realize the first part of this proposition. On the other hand, the subsequent deployment to the industry will be greatly facilitated if documentation is readily available to allow building on top of the prototype. On a side note, if the first iteration of this research meets tough challenges, it will also be much easier to track down what went wrong, whether it is the implementation or the realization that the research is not looking in the right direction.

As a result, what was deemed essential to this development process is:

- A detailed ConOps
- The system requirements
- The system design
- The verification of the system's features and attributes

On the other hand, the distinction between high-level design and detailed design, or a thorough and staged validation of each subsystem will not be documented. The outcome of this decision is that the amount of documentation will be slightly less than a formal system engineering approach would normally recommend.

With the aforementioned provisions, the system engineering process for this project will apply the framework of the Vee diagram. This means that, starting with the ConOps, the project team will gradually define and implement the system. Subsequently, the system will be tested and verified. Figure B-1 represents the overall Vee diagram for this project. Note that the FOT is shown in white. This reflects the fact that the FOT is not a part of this project, but rather a complement to it. Although its definition belongs to the current project, the project team will stop at the verification stage.

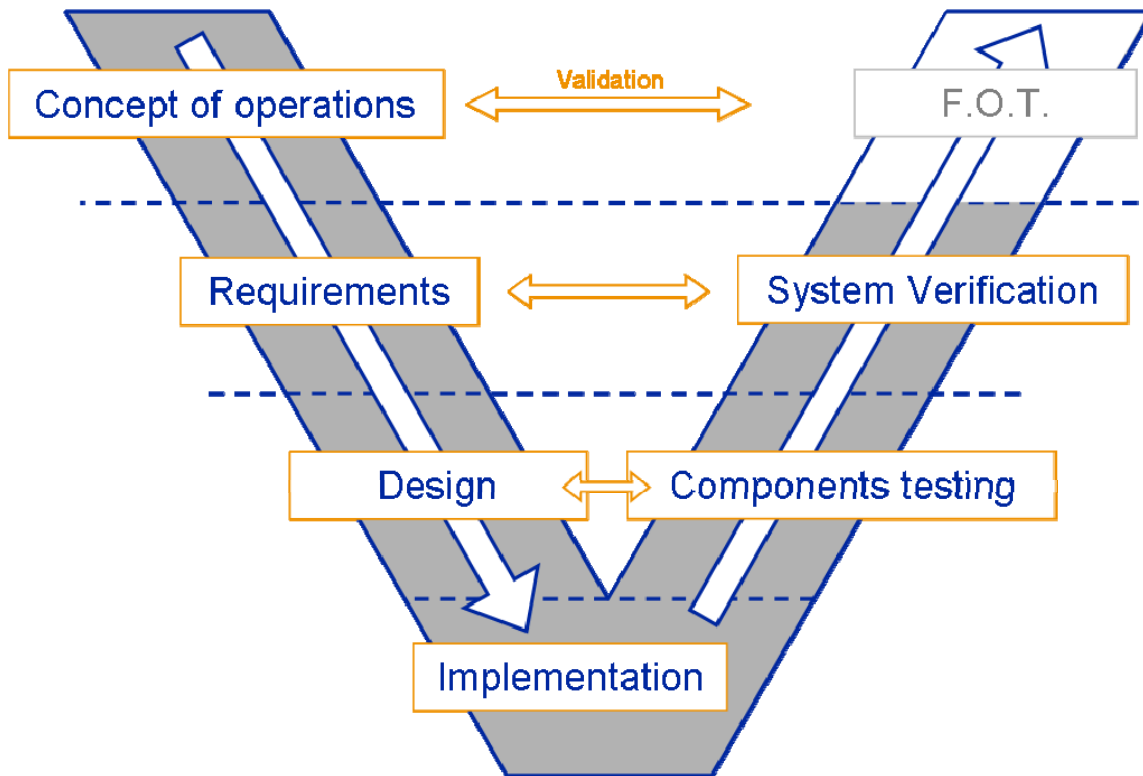

**Figure B-1 - Vee Diagram**

Referring to Figure B-1, the system engineering steps for this project are as follows:

- ConOps: outlines how the system operates in its intended environment and justifies why it can address the problem statement;
- Requirements Definition: the requirements clarifies in more details what the system has to accomplish, and spells out the performance targets;
- System Design: the system design documents how the system is going to be built, based on requirements. It includes the system architecture and the detailed design of individual subsystems;
- Implementation: the fabrication of the system and its subsystems;
- Components Testing: tests individual subsystems to insure that they function properly and that they conform to the design;

- System Verification: overall acceptance test for the assembled system, in order to verify how well it meets the requirements.

Each of these steps defines a corresponding control gate. Control gates refer to stages in the project where stakeholders get a chance to formally review project deliverables and agree on whether or not the project team should proceed to the next system engineering step. For this project, the control gates will take the form of review meetings with the Caltrans project manager and the FMCSA stakeholders. Meetings may take place in person or over the phone depending on the circumstances. The project team will deliver applicable documents and other deliverables for review meetings one week before the meeting. Control gates and their corresponding meetings are tentatively scheduled in the overall work plan.

### *B.2.3 Sequence of implementation*

A second consideration in adjusting the system engineering nominal development process was the tight timeframe allocated to the project. This essentially means that the development process cannot be linear. It should rather try to maximize the available time by conducting some of the tasks in parallel. In this area, the project team attempted to think creatively about the system engineering process. Although both a ConOps and some clear requirements need to be formulated for this project, they will only impact part of the product design. This stems from 2 reasons: 1) the basic requirements are already known: there needs to be an onboard computer that can read sensor inputs which are relevant to safe driving behavior; 2) PATH has already successfully implemented very similar systems in the past. Based on these observations, one can say that 1/3 of the system is already known from the project team, this said without in any way limiting the range of potentialities for the prototype.

As a result, the system engineering process for this project considered a “core” of components that are known to be part of the system to be developed, regardless of the decisions made in the ConOps. For these core subsystems only, the design can start almost immediately and funnel into implementation as needed, on a faster track than for the rest of the subsystems. This allows to spread some of the engineering resources over a longer period of time and to provide flexibility in the schedule.

Another acceleration step that was taken by the project team is an early start for the investigation of existing commercial off-the-shelf (COTS) sensors. Because most of the onboard sensors will be COTS or slight modifications thereof, and because there is not such a vast market, it is appropriate to start reviewing sensors regardless of what the requirements will say. This will essentially provide more schedule flexibility for the hardware group, freeing resources for the later stages.

The acceleration steps, namely the parallel track for the core subsystems and the early COTS investigation, is depicted in Figure B-2.

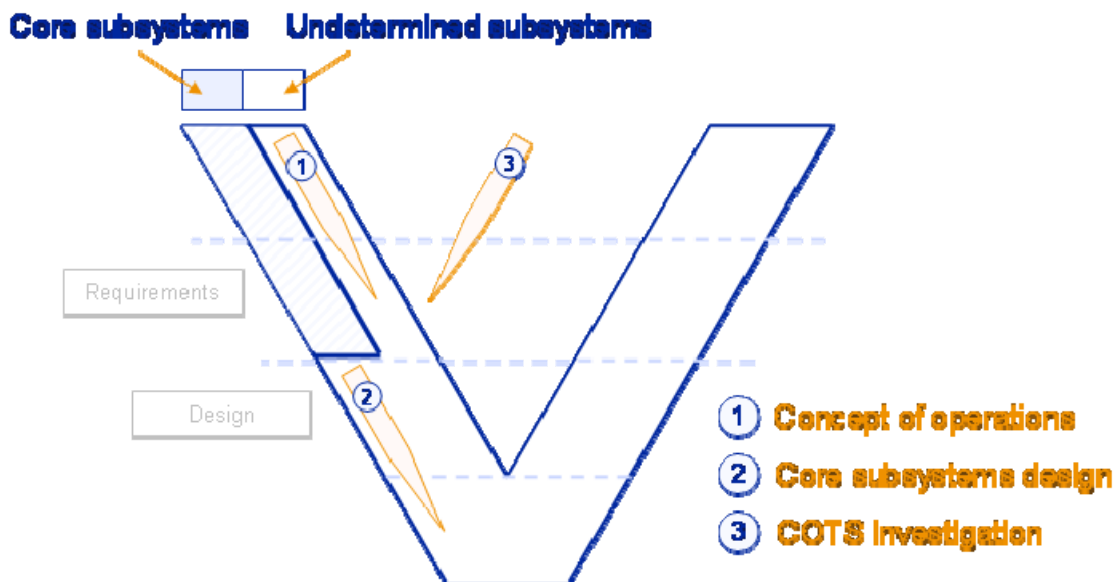

**Figure B-2 - Vee Diagram Acceleration**

Finally, it is to be noted that even though the FOT is not part of the present project, a task will be devoted to generating an overview of a FOT plan. Because the specifics of the FOT will be affected by multiple factors that will unfold throughout the project, the execution of the corresponding task will be kept relatively independent from the rest of the project. A major requirement of the FOT and of some of the tasks in the current project is the determination of the partner carrier. This will be tackled early in the project.

### *B.3 Engineering disciplines and integration*

This project will require the integration of multiple engineering disciplines. This section outlines these disciplines and show what their respective contributions to the project will be. In order to

control the integration of these disciplines as plans are developed and changes are made, a configuration management process will be applied. This process is described in section 3.2, Technical Plans.

The OBMS project includes the integration of five engineering specialties. The following bullet points provide a short description of each of them:

- Human factors: Human factors are the core-science of this project. Most accidents involve some kind of driver error. The system intends to warn drivers of behaviors that lead to dangerous situations, as they occur and/or through targeted feedback, which can ultimately reduce the number of crashes. Human factors will direct the ConOps and the system requirements. As such, this discipline will be instrumental all throughout the project to insure that the requirements are well captured by other disciplines. Human factors will also specify system user interfaces if applicable.
- Hardware engineering: The project product will be comprised of several hardware subsystems, including various sensors, a computer board, and potentially some user interfaces. These subsystems will be linked together and mounted onboard a truck. The hardware engineering group will select COTS hardware subsystems, design and build additional custom subsystems as needed, design and implement an architecture to interface the subsystems, and finally install the subsystems onboard the project truck.
- Software engineering: Software engineering will be required to program the onboard computer that sits at the center of the project system. Depending on the ConOps, software engineering may also be required to program user interfaces, whether onboard the truck or on a remote server. The software engineering group will design and implement the software subsystems.
- Data intelligence: Data intelligence refers to the set of algorithms that may be needed to process the flow of data from the selected truck sensors and assemble meaningful metrics as defined by the ConOps. Determining these algorithms requires a good understanding of the available data and how data from different sensors can be combined together. The data

intelligence group will participate in the selection of the onboard sensors, conduct extensive data analysis and design the data processing algorithms.

- Experiment design: The follow-up to this project will be a FOT intending to validate the system. The design of the FOT will be part of the research phase and is therefore included in this SEMP. The FOT design will define the experimental protocol that will be used to validate that the system has the potential to reduce accidents in a cost-effective manner. The experiment design group will lay out performance metrics that will be measured as part of the FOT, design test procedures, and develop a data analysis plan.

In addition to these five engineering specialties, two more disciplines are involved in the project:

- System engineering: System engineering is responsible for the overall prototype development process, including planning and tracking, engineering specialties integration, risk management, documentation and configuration management.
- Product deployment: The product deployment group will lay the ground for the ultimate commercialization of a product based on the outcome of this project. Their role is described in more detail in section B.5, Product Deployment.

Table B-1 provides a matrix indicating the specific application of the five engineering specialties through the system engineering process defined for this project. It shows how the disciplines will interact and complement each other throughout the six stages of the prototype development process. Note that these six stages correspond to Tasks 2 to 7 in the project plan.



Stages / Disciplines	Human Factors	Hardware Engineering	Software Engineering	Data Intelligence	Experiment Design
<b>1. Concept of operations</b>	<ul style="list-style-type: none"> <li>- Identifies accident factors</li> <li>- Defines safety attributes</li> <li>- Outlines feedback to the driver and/or the carrier management</li> </ul>	<ul style="list-style-type: none"> <li>- Provides inputs on feasibility within time and budget</li> </ul>	<ul style="list-style-type: none"> <li>- Provides inputs on feasibility within time and budget</li> </ul>	<ul style="list-style-type: none"> <li>- Insures that safety indicators can be derived from elementary sensor inputs</li> </ul>	<ul style="list-style-type: none"> <li>- Determines measures of success</li> <li>- Designs FOT protocol</li> </ul>
<b>2. Requirements</b>	<ul style="list-style-type: none"> <li>- Lists parameters to measure &amp; parameters boundaries</li> <li>- Develop application cases &amp; specifies feedback</li> <li>- Develop performance specifications</li> </ul>	<ul style="list-style-type: none"> <li>- Provides inputs on feasibility within time and budget</li> <li>- Investigates existing COTS sensors and defines the feasible envelope</li> </ul>	<ul style="list-style-type: none"> <li>- Provides inputs on feasibility within time and budget</li> </ul>	<ul style="list-style-type: none"> <li>- Links parameters to measure with safety indicators</li> <li>- Participates in sensors review to verify that parameters are available</li> </ul>	<ul style="list-style-type: none"> <li>- Designs verification procedures</li> </ul>
<b>3. System Design</b>	<ul style="list-style-type: none"> <li>- Check overall conformity of design to requirements</li> <li>- Participate in user interface design if any</li> </ul>	<ul style="list-style-type: none"> <li>- Selects COTS sensors</li> <li>- Designs custom sensors</li> <li>- Designs hardware architecture</li> <li>- Designs components mounts for truck</li> </ul>	<ul style="list-style-type: none"> <li>- Designs all software products, including input reading and processing software, analysis software, and reporting and warning software</li> </ul>	<ul style="list-style-type: none"> <li>- Analyzes data stream from sensors</li> <li>- Designs algorithms to fuse sensor inputs if needed</li> <li>- Designs algorithms to diagnose overall data</li> </ul>	
<b>4. Implementation</b>		<ul style="list-style-type: none"> <li>- Builds custom sensors if any</li> <li>- Assembles onboard computer</li> <li>- Builds mounts for onboard sensors</li> </ul>	<ul style="list-style-type: none"> <li>- Develop software subsystems</li> </ul>		
<b>5. Components testing</b>	<ul style="list-style-type: none"> <li>- Participates in testing of critical human factors components</li> <li>- Tests ergonomics of hardware and usability of software</li> </ul>	<ul style="list-style-type: none"> <li>- Tests hardware subsystems (performance, reliability, ruggedness...)</li> </ul>	<ul style="list-style-type: none"> <li>- Tests software subsystems (QA)</li> </ul>	<ul style="list-style-type: none"> <li>- Tests algorithms implementation</li> </ul>	<ul style="list-style-type: none"> <li>- Participates in components testing</li> <li>- Gets to know the developed system</li> </ul>
<b>6. System verification</b>	<ul style="list-style-type: none"> <li>- Verifies conformity to requirements</li> </ul>	<ul style="list-style-type: none"> <li>- Assists in overall system verification</li> </ul>	<ul style="list-style-type: none"> <li>- Assists in overall system verification</li> </ul>	<ul style="list-style-type: none"> <li>- Collects data from system</li> <li>- Verifies conformity of algorithms to requirements</li> </ul>	<ul style="list-style-type: none"> <li>- Applies verification procedures</li> <li>- Collects overall experiment data</li> </ul>

Legend:  Not involved  Light involvement  Significant involvement  Technical lead

**Table B-1 - Engineering Specialties Integration in the System Engineering Process**

#### B.4 Product deployment

The ultimate goal of this project is the deployment of a commercially available system that can reduce truck accidents. Reducing truck accidents will reduce fatality rates on the road, and can also translate into operational savings for trucking companies.

Because this project only intends to develop a prototype, deployment is one step remote. Yet, it will be examined and taken into consideration as part of the engineering decisions made during the project. This is one of the reasons why CCIT is involved in this project, and the deployment activities and how they should relate to engineering will be the responsibility of their group.

Dimensions to be examined as part of the overall deployment objective are captured by the following items:

- Quality and thoroughness of the product documentation

- Applicability of the design to a wider framework than the one of the project (alternative sensors procurement, different truck models, different drivers and company culture, different state regulations...)
- Intellectual property issues for transfer to an industry partner
- Benchmarking of the current market for truck safety products
- Tracking the assembly costs of the prototype to insure it stays within reasonable limits of what the industry typically accepts (per benchmark)

The deployment group will work with system engineering and the project manager to assess and monitor these dimensions.

#### *B.4.1 Project plans*

This section presents the work plan, deliverables, milestones, the technical plans, and the project management and reporting structure.

#### *B.4.2 Scope of work*

The overall scope of this project is to conceptualize, design, implement and test a prototype system to monitor truck driving safety in real-time and provide diagnostics. Additionally, a framework will be developed to evaluate the prototype in an operational environment. This requires finding a partner carrier.

The scope of work is made up of nine tasks, including a general management and reporting task (task 0). The nine project tasks are as follows:

Task 0. Management and Reporting

Task 1. Planning

Task 2. Develop ConOps

Task 3. Develop Requirements

Task 4. Develop System Architecture and Design

Task 5. Implementation

Task 6. Components Testing

Task 7. System Verification

Task 8. Develop FOT

The deliverables for the project are shown in Table B-2, along with the corresponding tasks.

**Table B-2 - Project Deliverables**

<b>Task / Index</b>	<b>Deliverable</b>
0ABCD	Quarterly Progress Reports
0E	Project Final Report
1A	System Engineering Management Plan
2A	ConOps (ConOps) Document
3A	System Requirements Document
3B	System Verification Plan
4A	System Design Document, including COTS specifications and Testing Procedures
5A	Developed Systems (Hardware and Software)
6A	Components Testing Report
7A	Prototype System Acceptance Test Report
8A	FOT Plan

### *B.5 Technical plans*

#### B.5.1 Integration plan

The Integration plan indicates when and how system components will be assembled together as part of the system as a whole. It spells out the sequence of integration, the procedures and criteria involved in the integration of specific components to the system and whether the integration

takes place on a test bench first or directly onboard the project truck. The integration plan will be completed as part of the system design.

<b>Integration Plan</b>	
<b>INPUT</b> <i>Sources of Information</i>	<ul style="list-style-type: none"> <li>• Hardware Development Plan</li> </ul>
<b>PROCESS</b> <i>Key Activities</i>	<ul style="list-style-type: none"> <li>• Review RFP/Work Plan and defined Task 4 Objectives</li> <li>• Review the Hardware Development Plan</li> <li>• Contact with vehicle manufacturer and maintenance personnel for vehicle functioning and build information</li> <li>• Envision methods that would integrate the hardware in the vehicle</li> </ul>
<b>OUTPUT</b> <i>Results from Process</i>	<ul style="list-style-type: none"> <li>• This Integration Plan</li> <li>• Detailed Integration Plan</li> </ul>
<b>Tools</b>	<ul style="list-style-type: none"> <li>• Vehicle maintenance and technical manuals</li> <li>• Microsoft Word for writing the plan</li> </ul>
<b>Review</b>	<ul style="list-style-type: none"> <li>• Draft plan will be submitted to customer and broader team for review. Written comments will be addressed and incorporated and customer approval will be received before moving to the next step in the process.</li> </ul>

### B.5.2 Configuration management plan

Configuration management is a tool designed to document and track changes made to the system and its components, whether it is features, hardware design, software versions etc... Once the system design is known, the system engineering team will set up and apply a configuration management process. The configuration management process will use an electronic document as a repository that will be accessible by each team member. This electronic document will likely be a MS Excel spreadsheet that will be organized in sections corresponding to the design areas. The configuration management spreadsheet will be a live document meant to be modified on the fly. Every month, the live version will be saved into an archive for future reference. This will establish a track of past configurations to document the prototype development.

<b>Configuration Management Plan</b>	
<b>INPUT</b> <i>Sources of Information</i>	<ul style="list-style-type: none"> <li>• System Engineering Management Plan</li> <li>• System Requirements Document</li> <li>• System Design Documents</li> <li>• Bi-Monthly meetings</li> </ul>
<b>PROCESS</b> <i>Key Activities</i>	<ul style="list-style-type: none"> <li>• Establish key characteristics of the system being developed (safety attributes to monitor, data metrics, hardware and software requirements, physical characteristics of the system...)</li> <li>• Map characteristics into a numbered list of qualitative and quantitative items.</li> <li>• Create a flexible spreadsheet structure to host these items.</li> <li>• Instruct the team on how to read and edit the spreadsheet.</li> <li>• Make the spreadsheet available on the project's FTP site.</li> <li>• Status accounting: every month, integrate inputs from the team and freeze the latest version for archiving. Inputs will be collected informally on a continuous basis and reviewed with the whole team before being frozen.</li> <li>• Audit changes: major configuration changes are fed back to the project's Change Control Board (CCB), comprising the project system engineering team, management team and sponsors for approval.</li> </ul>
<b>OUTPUT</b> <i>Results from Process</i>	<ul style="list-style-type: none"> <li>• Configuration management spreadsheet – initial baseline and monthly frozen versions.</li> <li>• The Change Control Board</li> <li>• A trail of past configurations and configuration changes, archived on a monthly basis.</li> <li>• Audit results</li> </ul>
<b>Tools</b>	<ul style="list-style-type: none"> <li>• Microsoft Excel</li> </ul>
<b>Review</b>	<ul style="list-style-type: none"> <li>• Initial spreadsheet will be reviewed by project management and sponsors for process approval.</li> <li>• Subsequent versions will be available for review on a continuous basis.</li> </ul>

### B.5.3 Verification plan

The verification plan spells out the procedures and measurements that will be employed to verify how well the built prototype meets the system requirements. The verification plan is a deliverable of Task 3, System Requirements.

<b>Verification Plan</b>	
<b>INPUT</b> <i>Sources of Information</i>	<ul style="list-style-type: none"> <li>• Requirements Document</li> </ul>
<b>PROCESS</b> <i>Key Activities</i>	<ul style="list-style-type: none"> <li>• Review RFP/Work Plan and define Task 3.5 Objectives</li> <li>• Review the Requirements Document</li> <li>• Envision tests that would verify system meets the requirements.</li> </ul>
<b>OUTPUT</b> <i>Results from Process</i>	<ul style="list-style-type: none"> <li>• This verification plan</li> <li>• A detailed verification plan</li> </ul>
<b>Tools</b>	<ul style="list-style-type: none"> <li>• The developed prototype system will be used to verify system performance</li> <li>• Other instrumented vehicles may be used in the verification testing</li> <li>• Matlab and/or other engineering software will be used to review and analyze raw and reduced data</li> <li>• Microsoft Word and Excel will be used for data management and report writing</li> </ul>
<b>Review</b>	<ul style="list-style-type: none"> <li>• Draft plan will be submitted to customer and broader team for review. Written comments will be addressed and incorporated and customer approval will be received before moving to the next step in the process.</li> </ul>

### B.5.6 Risk management plan

The risk management plan identifies individual project risks and indicates mitigation strategies. The risk management plan will be started at the beginning of the project and be augmented as necessary until the system design is completed. It will be modeled after the *FAA Programmatic Risk Analysis Approach*.

<b>Risk Management Plan</b>	
<b>INPUT</b> <i>Sources of Information</i>	<ul style="list-style-type: none"><li>• System Engineering Management Plan</li><li>• System Requirements Document</li><li>• System Design Documents</li><li>• Bi-Monthly meetings</li></ul>

<p><b>PROCESS</b> <i>Key Activities</i></p>	<ul style="list-style-type: none"> <li>• <u>Identify risks</u> <ul style="list-style-type: none"> <li>○ Begin with risks identified at onset of project and documented in kickoff               <ol style="list-style-type: none"> <li>1. Obtaining carrier partner</li> <li>2. OBM implementation (hardware and software)</li> <li>3. High quantity of reporting</li> </ol> </li> </ul> </li> <li>• <u>Analyze risks</u> and rank consequences       <ul style="list-style-type: none"> <li><i>Likelihood</i> <ul style="list-style-type: none"> <li>○ A: Not likely</li> <li>○ B: Low likelihood</li> <li>○ C: Likely</li> <li>○ D: Highly Likely</li> <li>○ E: Near Certainty</li> </ul> </li> <li><i>Consequence</i> <ul style="list-style-type: none"> <li>○ Level 1: Minimal impact</li> <li>○ Level 2: Minor performance shortfall, same approach retained</li> <li>○ Level 3: Moderate performance shortfall, alternatives available</li> <li>○ Level 4: Unacceptable performance, but alternatives available</li> <li>○ Level 5: Unacceptable performance, and no alternatives exist</li> </ul> </li> </ul> <p>Focus will be where <i>likelihood</i> x <i>consequence</i> is high.</p> <ul style="list-style-type: none"> <li>• Create a flexible spreadsheet structure to <u>monitor and track</u> risks, particularly where aforementioned product is high.</li> <li>• At each bi-weekly, address all risks with focus on higher level risks; <u>select risk mitigation option</u></li> <li>• During project execution, <u>implement risk mitigation decisions and plan</u></li> </ul> </li> </ul>
	<ul style="list-style-type: none"> <li>• Awareness and buy-in on risks</li> <li>• Tracking of risks</li> <li>• Risk mitigation plan</li> </ul>
<p><b>Tools</b></p>	<ul style="list-style-type: none"> <li>• Microsoft Excel</li> </ul>
<p><b>Review</b></p>	<ul style="list-style-type: none"> <li>• Bi-weekly with project team, to include Caltrans management</li> </ul>



### B.5.7 Plan for ConOps

This Task 2 effort is the marriage of a literature review, stakeholder feedback, and technical inputs, resulting in the ConOps document deliverable. As shown in the following table, there are four main tasks which will provide input to ConOps document. First, there is a COTS survey. Second there is an identification of causal factors in truck crashes. Third, there is a literature review on various specific and relevant Human Factors related issues, and finally, there is stakeholder input gathered during interviews and ride-alongs.

<b>ConOps Plan</b>	
<p><b>INPUT</b> <i>Sources of Information</i></p>	<ul style="list-style-type: none"> <li>• Product literature for COTS onboard monitoring systems</li> <li>• Reports published by the Center for National Truck and Bus Statistics</li> <li>• Peer-reviewed academic literature</li> <li>• Stakeholder input</li> </ul>
<p><b>PROCESS</b> <i>Key Activities</i></p>	<ul style="list-style-type: none"> <li>• Survey the market for COTS monitoring systems documenting what parameters the system monitors and how feedback is given to the drivers.</li> <li>• Review the literature published by the Center for National Truck and Bus Statistics to identify causal factors in the truck crashes</li> <li>• Review the literature that has been published on the topic of onboard monitoring and driver feedback</li> <li>• Review the literature on various driving performance measures such as speed, lane position, headway, and fatigue with intent to determine how to convert the monitored data into a measure of driving performance</li> <li>• Perform a task analysis during a ride-along with a stakeholder partner</li> <li>• Perform a management interview with a stakeholder partner</li> <li>• Develop application cases for the ConOps document</li> <li>• Develop driver feedback concepts for the ConOps document</li> </ul>

<p><b>OUTPUT</b> <i>Results from Process</i></p>	<ul style="list-style-type: none"> <li>● Onboard Monitoring ConOps Document <ul style="list-style-type: none"> <li>○ Provides a review of relevant literature</li> <li>○ Provides a survey of COTS monitoring systems</li> <li>○ Provides a draft concept of what parameters should be monitored</li> <li>○ Provides a rationale for how to use the monitored parameters to make a statement about driving performance</li> <li>○ Provides a draft concept of how feedback should be provided to the driver for each monitored parameter</li> </ul> </li> </ul>
<p><b>Tools</b></p>	<ul style="list-style-type: none"> <li>● Access to Science Direct, Ingenta Connect, and the UCB Library</li> <li>● Adobe Acrobat Reader (to read and print on-line literature)</li> <li>● Microsoft Word (for document development)</li> <li>● Video Camera (for recording interviews and ride-alongs)</li> </ul>
<p><b>Review</b></p>	<ul style="list-style-type: none"> <li>● Periodic presentations at the bi-weekly meetings will be provided to review the findings of the COTS survey, literature review, and stakeholder inputs.</li> </ul>

#### B.5.8 Hardware development plan

The hardware development plan will outline the implementation of required hardware components for the system, such as the tools to be employed and the distribution of tasks among the team. It will include test plans for the hardware components. The hardware development plan will be finalized when the hardware design is complete.

<b>Hardware Development Plan</b>	
<b>INPUT</b> <i>Sources of Information</i>	<ul style="list-style-type: none"> <li>• Requirements Document</li> </ul>
<b>PROCESS</b> <i>Key Activities</i>	<ul style="list-style-type: none"> <li>• Review RFP/Work Plan and defined Task 4 Objectives</li> <li>• Review the Requirements Document</li> <li>• Review Availability of COTS sensors and equipment</li> </ul>
<b>OUTPUT</b> <i>Results from Process</i>	<ul style="list-style-type: none"> <li>• This Hardware Development plan</li> <li>• A detailed hardware development plan</li> </ul>
<b>Tools</b>	<ul style="list-style-type: none"> <li>• Microsoft Word (for document development)</li> </ul>
<b>Review</b>	<ul style="list-style-type: none"> <li>• Draft plan will be submitted to customer and broader team for review. Written comments will be addressed and incorporated and customer approval will be received before moving to the next step in the process.</li> </ul>

### B.5.9 Software development plan

Software development will be required to interface COTS hardware and software to the onboard data gathering computer that sits at the center of the project system and to do any data filtering or archiving services required by the data intelligence operations. Depending on the ConOps, software engineering may also be required to program user interfaces for safety systems, based on data intelligence analysis, whether on board the truck or on a remote server.

<b>Software Development Plan</b>	
<b>INPUT</b> <i>Sources of Information</i>	<ul style="list-style-type: none"> <li>• ConOps plan and requirements document.</li> <li>• Hardware development plan and COTS system documentation.</li> <li>• Data intelligence plan and list of required data elements.</li> <li>• If user interfaces are part of the requirements, human factors input specification for the characteristics of the interfaces.</li> </ul>

<p><b>PROCESS</b> <i>Key Activities</i></p>	<ul style="list-style-type: none"> <li>• Identify major software subsystems and capabilities required of each.</li> <li>• Define and document data and control interfaces between hardware and software components.</li> <li>• Develop prototype software to test capabilities of COTS hardware and software.</li> <li>• Revise software subsystem capabilities and interface requirements based on results of COTS system testing.</li> <li>• Evolve prototype COTS testing software into a hardware and components test suite that can be used to check integrity of system</li> <li>• Write prototype data gathering software and collect initial data sets.</li> <li>• Add capabilities or improve performance as required for correct operation of safety system, based on data intelligence analysis carried out on initial data sets.</li> <li>• Develop regression tests to ensure integrity of software development as capabilities are added.</li> <li>• With human factors group, develop and carry out tests of any user ineterfaces. Iterate software process as required to address deficiencies identified by testing.</li> <li>• Document software and testing procedures.</li> </ul>
<p><b>OUTPUT</b> <i>Results from Process</i></p>	<ul style="list-style-type: none"> <li>• Software for data gathering and safety systems.</li> <li>• Test software for system components and software integrity.</li> <li>• Documentation for software and testing procedures.</li> </ul>
<p><b>Tools</b></p>	<ul style="list-style-type: none"> <li>• Real-time operating system for data gathering – QNX6 or (possibly) a real-time version of Linux.</li> <li>• C programming language and Unix scripting and filtering tools.</li> <li>• Open-source package <i>doxygen</i> for automatic generation of software documentation in .pdf or .html format.</li> <li>• User interface development package may be needed.</li> </ul>
<p><b>Review</b></p>	<ul style="list-style-type: none"> <li>• Quarterly reports will be submitted to customer and broader team for review. A web page will be maintained containing current software documentation.</li> </ul>

#### B.5.10 Data Intelligence Plan

The data intelligence plan will outline the scope and extent of data intelligence tasks for this project. Data intelligence will be concerned with the safety measurements defined by the system requirements and how to assemble these measurements from available sensor inputs. The plan will indicate how data will be collected and analyzed so that algorithms can be properly calibrated, what tools will be used, and how the adherence of the system data processing algorithms to the requirements will be measured. The data intelligence plan will be produced once the requirements are completed.

The objective of the project is for on board monitoring with some feedback reminding (warning) to the driver, which is to be determined with the iterative development of the project. Sensor specification, detection, tracking, information from J-1939 Bus and data fusion will depend on the system performance requirement. Some of the measures will be processed in real-time to provide feedback to the driver. Other data will be collected for after processing to analyze driver's behavior related to safety.

<b>Data Intelligence Development Plan</b>	
<b>INPUT</b> <i>Sources of Information</i>	<ul style="list-style-type: none"> <li>• List of parameters to be monitored</li> <li>• List of sensors</li> <li>• Description of data from sensors</li> <li>• Requirement of feedback to the driver</li> <li>• Requirement of data logging for after processing</li> <li>• Dangerous situation in operation</li> <li>• Previous work in Warning System Study including threat assessment</li> </ul>
<b>PROCESS</b> <i>Key Activities</i>	<ul style="list-style-type: none"> <li>• According to the requirement to develop tracking and sensor fusion algorithm</li> <li>• According to the specification, development and Implementation of threat assessment algorithm for heavy-duty truck for longitudinal motion</li> <li>• With human factors group, develop warning scenarios and feedback if necessary</li> <li>• System integration of on board signal processing, monitoring of driver's operation regulation violation, and threat assessment</li> <li>• Field testing and data analysis</li> <li>• Data off-line processing</li> <li>• System refining</li> </ul>
<b>OUTPUT</b> <i>Results from Process</i>	<ul style="list-style-type: none"> <li>• Multiple frontal target detection and tracking using radar and lidar</li> <li>• An integrated system for real-time signal processing , monitoring of driver's operation regulation violation, threat assessment and warning</li> <li>• Documentation for algorithm, software and testing procedures</li> </ul>
<b>Tools</b>	<ul style="list-style-type: none"> <li>• Real-time operating system for data processing such as QNX. 6.0</li> <li>• C programming language</li> <li>• Matlab packages</li> </ul>

<b>Review</b>	<ul style="list-style-type: none"> <li>• Quarterly reports will be submitted to customer and broader team for review.</li> <li>• Customer’s feedback will be incorporated in system tuning and refining.</li> <li>• A web page will be maintained containing current algorithm, software, and system documentation.</li> </ul>
---------------	--

*B.6 Team, resources and organization*

**B.6.1 Staff and Resources**

PATH is the primary contractor for this project. The project team comprises PATH staff members as well as staff from other Transportation Research Centers at the University of California, Berkeley. In addition, a professional system engineer was hired on a subcontract.

**B.6.2 Organization**

The project team is organized under the responsibility of the project manager. For each engineering discipline, a group leader is designated and bears responsibility for carrying out specific tasks, providing deliverables, and acting as a coordinator for their discipline. This means reporting to the project team as a whole and being a liaison with other disciplines.

Figure B-3 represents the overall organization chart for this project. It includes the yet-to-be-determined partner carrier. Tan boxes indicate the groups that specifically belong to the project.

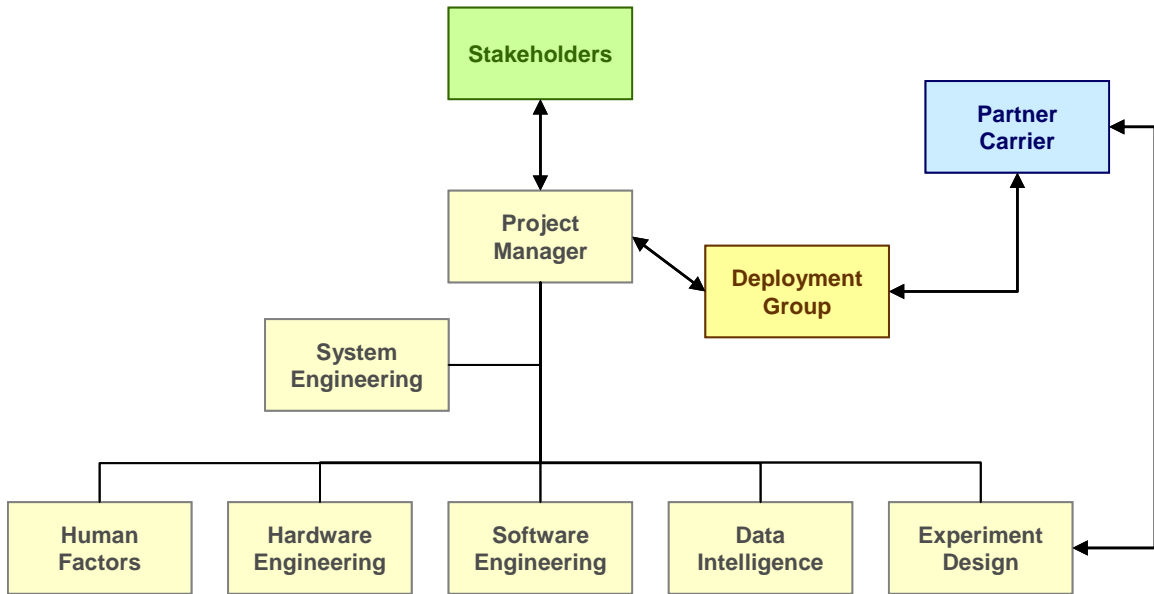

**Figure B 3 - Project organizational chart**

*Throughout the project, meetings will be held to allow updates within the project team. The nominal frequency of team-wide meetings is one meeting every other week.*



**APPENDIX C. SYSTEMS REQUIREMENTS DOCUMENT**

**Onboard Monitoring and Reporting for Commercial Motor Vehicle Safety:**

**System Requirements**

---

*California PATH*  
Thomas Koo  
Scott Johnston  
Jim Misener

*California Center for Innovative Transportation*  
J.D. Margulici  
Kenneth Kuhn

---

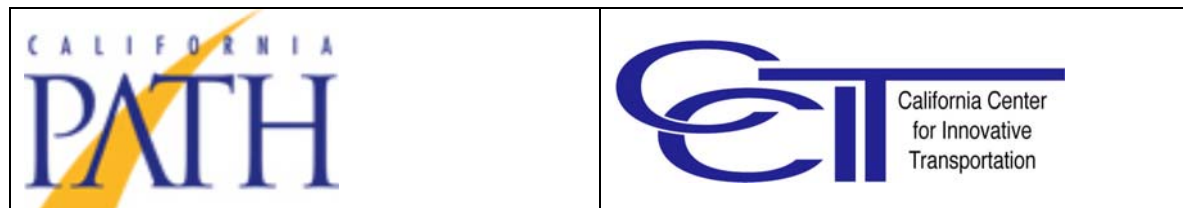

---

## GLOSSARY OF ACRONYMS, ABBREVIATIONS AND SYMBOLS

Caltrans:	California Department of Transportation
CAN:	Controller Area Network
CCIT:	California Center for Innovative Transportation, UC Berkeley
CMV:	Commercial Motor Vehicle
<b>COM</b> :	Designates a requirement that applies only to ultimate commercialization
COTS:	Commercial Off-The-Shelf (commercially available product)
DRI:	Caltrans' Division of Research and Innovation
DSP:	Digital Sound Processor
EOBR:	Electronic On-Board Recorder
FHWA:	Federal Highway Administration
FMCSA:	Federal Motor Carrier Safety Administration
FOT:	FOT
<b>FOT</b> :	Designates a requirement that applies to the FOT but not to the prototype
GIS:	Geographical Information System
GPS:	Geographical Positioning System
GUI:	Graphical User Interface
HOS:	Hours Of Service
LCD:	Liquid Crystal Display
LDWS:	Lane Departure Warning Systems
MTBF:	Mean Time Between Failures
MVMT:	Million Vehicle Miles Traveled
NEMA:	National Electrical Manufacturers Association
NTSC:	National Television Standards Committee
OBMS:	On-Board Monitoring System
OBP:	On-Board Processor
OEM:	Original Engineering Manufacturer
PATH:	Partners for Advanced Transit and Highways, UC Berkeley
RODS:	Records Of Duty Status
RPM:	Revolutions Per Minute
SAE:	Society of Automotive Engineers

TBD: To Be Determined  
TPM: Technical Performance Measure  
VHT: Vehicle-Hours Traveled  
VMT: Vehicle-Miles Traveled

## **C.1 BACKGROUND AND SCOPE**

### *C.1.1 Background*

The project's scope of work is to develop a prototype system that measures a set of driving characteristics which are indicators of unsafe driving behavior, and that provides appropriate feedback to drivers and fleet managers. Once a first prototype is developed, the project team will test it on a Class 8 tractor owned by Caltrans.

A subsequent research award would allow a FOT , consisting of a limited deployment of the product of the present research project on a fleet of commercial vehicles in order to test and validate the concept. The ultimate goal is to demonstrate a set of innovative safety features that can be replicated and commercialized by trucking equipment manufacturers, and to formulate safety policy recommendations depending on the outcome of the research.

Appendix C supports this project by providing a nominal 'first pass' during the prototype stage set of requirements for an final OBMS. The process of determining final requirements is of course iterative and results of the subsequent FOT will figure prominently.

### *C.1.2 Applicable documents*

- Onboard Monitoring and Reporting for Commercial Vehicle Safety, System Engineering Management Plan, PATH / CCIT, January 2006
- Onboard Monitoring and Reporting for Commercial Vehicle Safety, ConOps – Draft, PATH / CCIT, May 2006

### *C.1.3 Definitions*

The following definitions are used as part of the system requirements.

Crash: accident involving a collision.

Driver attention: is an assessment of the driver's concentration on their task.

Driver fatigue: refers to a state of tiredness on the part of driver, which impairs good judgment and reflexes.

Event: any occurrence of certain circumstances and / or parameter values crossing defined thresholds that reveals a specific action taken by the driver or is a safety hazard.

Following distance: distance between the CMV and the vehicle immediately leading it on the same lane.

Notice: a signal meant to inform the driver, for instance about the risk associated with a certain situation or action. A notice is intended as less intrusive than a warning.

Parameter: any variable, measurable property whose value characterizes the state of the vehicle or the behavior of the driver.

Roadway curvature: is defined as the inverse of the roadway curve radius.

Vehicle parameters: generally refers to engine and other vehicle parameters that are readily available on CMV CAN buses. Includes in particular engine RPM, clutch pressure and release, fuel consumption rate, etc...

Warning: a visual or audible signal meant to alert the driver of a potential threat or dangerous action.

#### *C.1.4 System overview*

The system described in this document (thereafter referred to as “the system”) intends to improve the safety of CMV fleet operations by (1) recording and monitoring hours of service, driver input commands, vehicle states, and environmental conditions on each equipped vehicle and (2) providing recommended driving behavior by using real-time feedback devices or offline feedback procedures.

The system architecture comprises five logical sub-systems as follows:

- On-board processing unit (OBP): This is the system core, which acquires and processes all the data being collected by the system.
- Sensors: A set of sensors provides behavioral and environmental parameters to the OBP.
- Driver interfaces: This sub-system encompasses all the means of interactions between the system and the driver, including real-time feedback.

- Data storage device: An on-board memory storage device that records monitored parameters and events.
- Analysis module: A PC program that processes data recorded on the data storage device and provides analysis of driving behavior.

Note that, with the exception of the analysis module which will typically be deployed in the fleet dispatch, all sub-systems are replicated on each equipped vehicle. In addition to the five sub-systems, hardware mounts and cables insure the integration of the on-board components to a truck. Figure 1.1 depicts the overall system architecture.

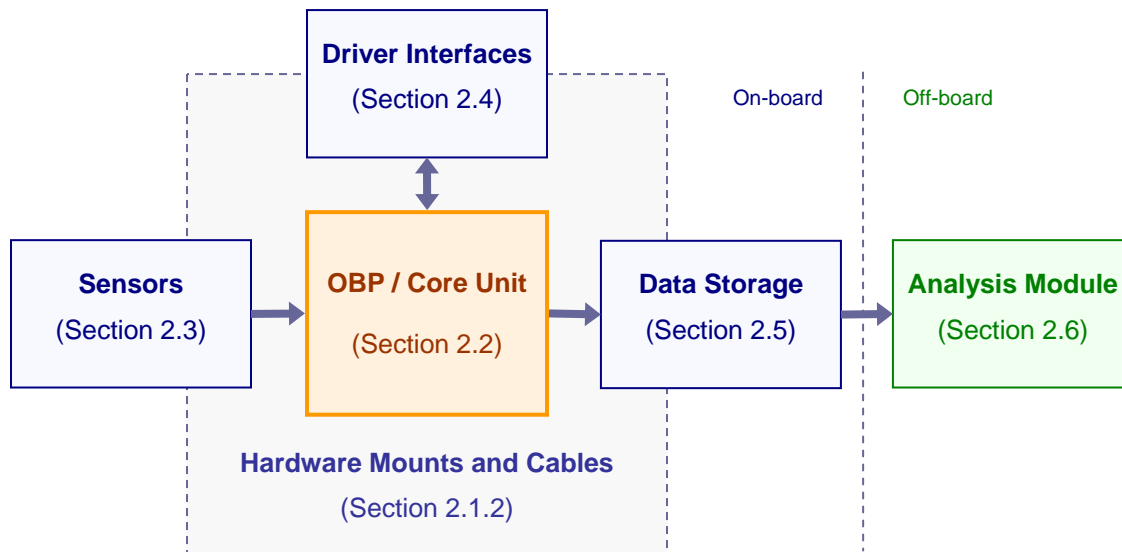

**Figure C.1 - Overall System Architecture**

The proposed system uses various sensors, including Commercial-Off-The-Shelf (COTS) systems. In some cases, these COTS systems are self-contained units that can operate independently. As such COTS are integrated into the system, their nominal modes of operations will still be used. The purpose of this research is to seek benefits from their integration to a larger onboard monitoring suite, while maintaining regular use. For example, a Lane Departure Warning System will provide lane positioning to the system while still issuing a warning to the truck driver in case of an uncontrolled lane change.

The OBP stores a set of recommended driving behaviors as the reference. It continuously compares driving behavior with referenced behavior. Technically, the system distinguishes between monitored parameters for which there are continuous values over time (e.g. speed or lane positioning) and events, which are occurrences of a specific set of circumstances or parameter values (e.g. speeding or non-signalized lane change). Certain events or behaviors can trigger real-time feedback in the form of visual or audible notices to the driver. In addition, data and events are recorded into the data storage device for later retrieval. The data recorded in the storage device is then processed by the offline analysis module in the back-office. The analysis module produces safety metrics that can be tracked over time to determine general driving behavior and monitor progress.

In summary, the system provides 3 types of feedback:

- Real-time warnings indicating immediate threats. These warnings all stem from COTS components and will be integrated “as is” into the system.
- Real-time feedback in the form of visual or audible notices. Such notices signal potentially unsafe behaviors but intend to be less intrusive than a warning. Moreover, notices are only delivered in situations that allow corrective action by the driver.
- Off-line feedback in the form of summary statistics. Summary statistics synthesize the parameter values and event data being logged by the on-board sub-systems and intend to provide a comprehensive picture of driving behavior.

(It is noted that real-time and off-line feedback are not necessarily mutually exclusive.)

At a glance, the system can monitor the following driving attributes and events: hours of service, seat belt usage, speeding, following distance, lane positioning, turn signal usage, blind spot checks, driver attention and fatigue, collision and lane departure warning activations, stop signs violations, hard-steering events, hard-breaking events and crash events.

#### *C.1.5 Document scope*

This document establishes the design requirements of the proposed system and the associated sub-systems. The requirements covered in this document include functional requirements,

interface requirements, performance and environmental requirements, as well as various enabling requirements to allow proper design and fielding of the system.

The intended audience of this document comprises the project team, the project sponsors, and system stakeholders, including equipment manufacturers, fleet managers and policy makers. The level and detail of the requirements vary for different sub-systems and features, based on what is deemed necessary to provide the intended audience with a clear understanding of the intended functions of the system, of its constraints, and of significant enabling factors and conditions.

One particular challenge to this document is that the system will be developed iteratively over several stages. As part of the current stage, a single prototype will be developed. For the subsequent FOT, it is expected that additional constraints will be factored in to allow the fielding of the system in an operational environment. Ultimately, the system, or part of it, may be commercialized, which will impose yet another set of requirements. Moreover, as feedback on the system effectiveness and relevance is collected at each stage, the requirements will evolve. Yet, it is clear that stakeholders need to capture the ultimate system vision to be able to validate the requirements. In order to deal with this issue, the requirements in this document are usually inclusive of what is needed to deploy the system on a commercial fleet (although requirements specifically aimed at making the system into a commercial, rugged product are not included). However, to distinguish between requirements that are immediately applicable and requirements that can be put off to a later stage, two labels are used: **FOT** designates requirements that will be needed for FOT fielding, but won't be considered for the prototype; **COM** designates requirements that will not even be applied for the FOT, but would ultimately be needed for commercial deployment. Therefore, only non-labeled requirements apply to the prototype development in this project.

The requirements are grouped in section C-2, which is organized in six sub-sections: the first sub-section spells out general requirements at the system level while the following sub-sections provide requirements for each of the individual sub-systems outlined in section C.4. Figure C.1 indicates the corresponding document section for each sub-system. Note that the Hardware Mounts and Cables requirements are part of the general system interface requirements (section C.4.2).



## **C-2 SYSTEM REQUIREMENTS**

### *C.2.1 General system requirements*

This section describes requirements for the system as a whole, including general-purpose requirements that flow down to sub-systems.

### *C.2.2 Functional requirements*

#### *C.2.3 System mission*

The system shall improve the safety of CMV fleet operations by (1) recording and monitoring hours of service, driver input commands, vehicle states, and environmental conditions on each equipped vehicle and (2) providing recommended driving behavior by using real-time feedback devices or offline feedback procedures.

#### *C.2.4 Applicability*

The system shall be designed for a fleet of CMV. On-board sub-systems shall be installed and able to perform nominally on any CMV that has the required interfaces. FOT

#### *C.2.5 Monitoring functions*

Monitoring functions can be separated between parameters and events. Parameters are monitored on a continuous or near-continuous basis. Events are occurrences of specific circumstances or sets of parameter values.

##### *a. Driving parameters*

The system shall monitor, record, process and summarize the following parameters:

<i>Parameter ID</i>	<i>Description</i>
<i>P1</i>	<i>Driver identification Unique driver ID</i>
<i>P2</i>	<i>Following distance</i>
<i>P3</i>	<i>Hours of service Hours logged by driver</i>
<i>P4</i>	<i>Lane position Computed tracking value as compared to lane delineators</i>
<i>P5</i>	<i>Road surface conditions Dry, Wet, Icy, Fog, Snow</i>
<i>P6</i>	<i>Roadway curvature</i>
<i>P7</i>	<i>Roadway scenery Video</i>
<i>P8</i>	<i>Seat belt usage</i>
<i>P9</i>	<i>Vehicle location Latitude &amp; Longitude</i>
<i>P11</i>	<i>Speed</i>
<i>P12</i>	<i>Brake pressure</i>
<i>P13</i>	<i>Steering angle</i>
<i>P14</i>	<i>Occupancy of side lanes Binary measure</i>
<i>P15</i>	<i>Turn signal use</i>

*b. Events*

The system shall identify and record the following events:

<i>Event ID</i>	<i>Description</i>
<i>E1</i>	<i>Crash events</i>
<i>E2</i>	<i>Driving more hours than legal maximum</i>
	<i>Based on Federal Regulation CFR III-395.15 of Title 39 and California Code Section 1213.2</i>
<i>E3</i>	<i>Driving without seat belt</i>
<i>E4</i>	<i>Following too close</i>
<i>E5</i>	<i>Hard-breaking events</i>
<i>E6</i>	<i>Hard-steering events</i>
<i>E7</i>	<i>Non-signalized turns</i>
<i>E8</i>	<i>Speeding with respect to legal speed limit</i>
<i>E9</i>	<i>Speeding with respect to weather and road surface conditions</i>
<i>E10</i>	<i>Speeding with respect to road curvature conditions</i>
<i>E11</i>	<i>Speeding with respect to traffic flow conditions</i>
<i>E12</i>	<i>Stop signs violations</i>
<i>E13</i>	<i>Initial failure to adjust mirrors</i>

***E14 Excessive lateral acceleration***

***E15 Fatigue***

***E16 Lane Departures***

***E17 Eyes-Off-The-Road***

***E18 Failures to check mirrors***

***E19 Forward collision threats***

#### ***C.2.6 Feedback functions***

The system shall deliver three types of feedback:

- Real-time warnings
- Real-time advisory notices
- Off-line feedback

It can also deliver both real-time and off-line feedback.

##### ***a. Real-time warnings***

The system shall deliver real-time warnings in response to the following events:

- Forward collision threat
- Roll-over danger
- Side collision threat
- Unintended or non-signaled lane departure

These warnings shall be delivered by COTS components.

##### ***b. Real-time advisory notices***

The system shall deliver real-time audible or visible notices in response to the following events:

- Speeding
- Following too close
- Driving over the legal maximum number of hours
- Driving without seat belt (to include % time)
- Alerts given by COTS systems used in OBMS

*c. Off-line feedback*

The system shall deliver off-line feedback based on summary statistics of recorded parameters and events. Specific statistics will be based on results of the FOT.

*C.2.7 Data management*

Individuality

The system shall treat each driver and each CMV in a fleet as individual, identified entities.

Data recorded for a given driver on a given truck shall be stamped as such. **FOT**

Confidentiality

The system shall treat personal information about driving behavior with confidentiality throughout all sub-systems and interfaces. Access to the data shall be restricted accordingly.

**FOT**

Security

Because data may be sensitive and even have legal implications, its integrity and confidentiality shall be guaranteed by security measures: physical access, passwords, and cryptography. **COM**

Extensiveness

The amount of data collected and kept is determined by individual safety features. However, all data monitored by the system shall be recorded and accessible for later retrieval and consultation, at least in summary format.

## *C.2.8 Interface requirements*

### *C.2.8.1 On-board interfaces*

#### J-Bus

The CMV that hosts the system shall feature a Control and Communications Network that complies with **standard**. Sensing equipment shall be present that provides baseline vehicle parameters.

#### Physical space

The CMV cabin shall offer the required amount of physical space and electrical power to host the system, including the on-board processing units, the sensors and the cables and mounts.

#### Existing on-board sensors

Any sensor pre-existing on a CMV may be interfaced to the system if it meets the functional, performance and interface requirements described in the relevant section of this document.

### *C.2.8.2 Off-board interfaces*

#### PC computer

The system requires a PC computer to run the analysis module.

## *C.2.9 Performance and environmental requirements*

### *C.2.9.1 Mission*

#### Crash reduction

The system shall reduce the statistical occurrence of crashes on the fleets on which it is equipped, as measured by number of crashes per million vehicle-miles traveled (MVMT).

#### Casualty reduction

The system shall reduce casualties involving equipped CMV per MVMT.

#### Safety-related behavior improvements

The system shall lead to safer behaviors by drivers operating within an equipped fleet. Specific Technical Performance Measures (TPMs) to track overall safety-related behavior will be based on the results of the FOT.

#### *C.2.10 Reliability*

##### Up-time

Overall system up-time is defined as the availability of all sub-systems and functions to perform nominally. System failure is the opposite of up-time. Up-time requirements are expressed in terms of Mean Time Between Failures (MTBF).

##### Data reliability and accuracy

Data reliability is defined as a percentage of operating time when measurements are within a tolerable margin of error from the actual parameter being measured.

Data accuracy for a given parameter being monitored is defined as the average error over time between measurements and actual values of the parameter.

Data reliability is defined as the percentage of occurring events being recorded by the system.

##### False positives

False positives are instances where the system records one of an event even though it did not occur. The system shall minimize the number of false positives, measured as the ratio of false positive instances to MVMT.

##### Resilience

The system as a whole shall be able to handle down-times of its components. In particular:

- The OBP unit shall still function, although in degraded mode, when other parts of the on-board elements are down. FOT
- The analysis module shall be able to acquire and process the down-times of on-board elements, and produce analysis accordingly. COM

### *C.2.11 Environmental constraints*

#### Ambient conditions

On-board elements shall withstand the following conditions:

- Temperature: the ambient air temperature range is -55F to 125F for operating conditions and -55F to 200F for non-operating conditions. FOT
- Relative humidity: the ambient relative humidity range is 0% to 100%. FOT
- Atmospheric pressure: the absolute pressure range (not corrected to sea level) is between 16.8 and 31.4 inches of mercury (427 and 797 millimeters of mercury, respectively). FOT

#### Cabin safety

On-board hardware elements, cables and mounts shall observe the following constraints pertaining to cabin safety:

- Driver sight: the system shall not block driver sight.
- Driver motion and access: the system shall not impair driver's movements or interfere with original equipment and commands in the vehicle.
- Electrical safety: the system shall not represent an electrical hazard. Fuses or safety breakers shall limit current flow to a maximum value.
- Feedback and warnings: feedback and warnings shall be delivered in a way that does not overload the driver or adds undue stress.



## Cabin security

To insure the security of the system the system elements in the cabin shall conform to the following:

- Physical security: the hardware elements, cables and mounts shall be hidden from the driver to the extent possible, with the exception of the user interfaces. FOT
- Tamper-proof design: data communications between the sensors and the core processing unit, as well as data storage, shall be secure and tamper-proof. COM

## Human factors

On-board elements shall guarantee cabin comfort in the following ways:

- Physical comfort: the system shall not affect driver comfort by limiting available space or creating physical annoyance.
- Sonic and visual comfort: the system shall not provoke sonic or visual discomfort unless the safety benefits of such discomfort are clear.
- Driver interfaces: driver interfaces (i.e. vehicle identification reader, video devices, memory storage) shall be simple, effective and non-intrusive.
- Interfaces layout: physical access to the driver interfaces shall be easy and convenient.

## C.3 Enabling requirements

### *C.3.1 COTS components*

The system shall be designed with available COTS to the extent that they can meet functional requirements in a cost-effective manner. All-purpose requirements apply to COTS and original-design components alike. Specific requirements for COTS components are usually not included in this document, based on the following statement:

*COTS components shall be selected on the basis of performance / cost ratio and be positioned as industry standards in their product class, unless otherwise specified.*

The following sensors and information sources shall be included in the system. These come in addition to baseline sensing equipment that shall be present in trucks on which the system is installed (see 2.1.2.1.1).

Sensor	ID
S1	Accelerometer
S2	Driver ID reader
S3	Electronic On-Board Recorder (EOBR) / Hours of Service (HOS)
S4	Front radar / warning system
S5	GIS roadway map
S6	GPS receiver
S7	Lane position monitor
S8	Outward video camera
S9	Road surface conditions sensor
S10	Rollover sensor
S11	Side radar (2)
S12	Steering angle sensor
S13	Thermometer
S14	Throttle angle sensor
S15	Wheel speedometer
S16	Wiper usage monitor
S17	Brake pressure monitor
S18	Mirror adjustment monitor
S19	Turn signal monitor
S20	Seatbelt usage monitor
S21	Driver camera

### *C.3.2 Design and upgrades*

#### Modular design

The system shall be designed in a modular fashion that allows interchangeability of sensors and acquisition functions.

#### Software design

The software design shall be in accordance with industry best practices such as CMMI or ISO 12207 software development standards. 

### Upgradeable design

The design shall allow software upgrades to be carried out simply and speedily. Similarly, sensors and other hardware upgrades shall be easy, based on the modular design required in C.4.2.1.

### *C.3.3 Installation and setup*

A CMV fleet being outfit with the system shall bear minimum cost and disruption to its regular operations. Deployment at one given site or dispatch station consists of the following steps:

- Installation and configuration of on-board components on individual trucks
- Installation and setup of the analysis software on selected dispatch computers
- User training, both for drivers and users of the analysis module

The following TPM shall be employed:

#### On-vehicle installation

Installation and testing of the on-board components shall not immobilize individual vehicles for more than 1 day. The process shall not require more than 2 people.days. FOT

#### Analysis module installation

Installation and configuration of the analysis software shall be conducted in a maximum of x days + y days / n vehicles in the fleet. COM

#### Driver training

Training of the drivers for the on-board functions shall require less than 1 day. FOT

#### Analysis training

User training for the analysis module shall require less than 1 day. FOT

### *C.3.4 User acceptance*

One key hurdle faced by the system is driver acceptance. The system shall be designed and evaluated so as to maximize acceptance likelihood by drivers and managers in CMV fleets. Acceptance shall be considered in the comprehensive context of fleet operations and not be limited to on-board elements feedback.

### *C.3.5 Maintainability*

The system shall be easy to maintain and not generate excessive added burden on CMV fleet operations and costs. Because of the system complexity and the multiplicity of its components (i.e. sensors), a maintenance plan shall be developed for equipped fleets. FOT

## **C.4 On-board processing unit (OBP) requirements**

### *C.4.1 Functional requirements*

#### *C.4.1.1 Operating modes*

The OBP shall feature the following operating modes:

- Off-mode: No power. Occurs when the ignition is off or if the system is manually shut-down.
- Diagnostics mode: In this mode, the OBP diagnoses the on-board system elements. The OBP automatically switches to this mode when the truck ignition is turned on. Subsequently, the diagnostics mode is intertwined with the monitoring and recording mode to allow continuous diagnostics. FOT
- Monitoring and recording: Nominal mode, during which the OBP monitors, records and processes parameters and events.
- Memory access mode: This mode allows transfer of stored data off the vehicle.
- Degraded mode: A generic mode to describe monitoring and recording when parts of the on-board elements are failing. COM

#### *C.4.2 Data recording*

The OBP shall record values of monitored parameters and event occurrences in the onboard data storage.

Each record shall include the following information:

- Driver identification FOI
- Time stamp

#### *C.4.3 Monitored parameters*

The OBP shall monitor the following parameters:

Driver identification

The OBP shall acquire driver identification and stamp each recorded data with this information.

Following distance

The OBP shall monitor and record actual following distance.

The OBP shall compute and record a safe following distance based on the following inputs:

- Vehicle speed
- Trailer load
- Roadway surface conditions

The OBP shall continuously compare the actual following distance and the calculated safe following distance. The OBP shall determine occurrences of unsafe driving behavior based on a set of criteria involving those two parameters.

#### Hours of service

The OBP shall monitor and record operating hours by driver. The OBP shall compare these hours with the federal (Federal Regulation CFR III-395.15 of Title 39) and local regulations (in California, California Code Section 1213.2) and determine occurrences of violations.

#### Lane position

The OBP shall monitor and record the vehicle's position relative to lane delineators.

#### Road surface conditions

The OBP shall monitor and record the road surface conditions. Road surface conditions shall be characterized, at a minimum, with the following criteria:

- Dry road
- Wet road
- Icy road
- Fog over the road
- Snow on the road

#### Roadway curvature

The OBP shall monitor roadway curvature ahead of the trajectory of the truck, based on a GPS / GIS system.

#### Roadway scenery (video)

The OBP shall monitor and record roadway scenery ahead of the truck. Recording shall be implemented as a 5 min-buffer which is overwritten on a cyclical basis. At any given moment, the last 5 minutes of video footage shall be stored by the OBP in the data storage device.

### Seat belt usage

The OBP shall monitor and record seat belt usage when the engine is on.

### Speed

The OBP shall monitor and record vehicle speed.

The OBP shall monitor and record a recommended safe speed based on the following inputs:

- Legal speed limit, as provided by a GPS / GIS system
- Roadway curvature ahead, also provided by a GPS / GIS system
- Road surface conditions
- Weather

The OBP shall continuously compare vehicle speed and recommended safe speed. The OBP shall determine occurrences of unsafe driving behavior based on a set of criteria involving those two parameters.

### Vehicle location

The OBP shall monitor and record vehicle location based on GPS.

### Brake pressure

The OBP shall monitor and record the pressure applied to the brake pedal.

### Steering angle

The OBP shall monitor and record the angle of the steering wheel.

### Occupancy of side lanes

The OBP shall monitor and record whether or not there are objects in the spaces on either side of the vehicle.

## Turn Signal Use

The OBP shall monitor and record whether or not the turn signals are in use.

### *C.4.4 .Monitored events*

While parameters are state variables that can be described as steady data streams, events are isolated occurrences in time resulting from a set of specific circumstances and parameter values. Events occurring while driving will usually call for a response by the system, or at least be logged in an event list that contributes to the analysis of driving patterns and behavior. The OBP shall catch and record the following events:

#### Crash events

The OBP shall detect and record crashes. Crash events shall cause video data, both inside and outside the vehicle, to be permanently recorded for later retrieval.

#### Driving over the legal maximum number of hours

The OBP shall detect and record occurrences of a driver exceeding the legal maximum of service hours. Service hours are tracked as required by 2.2.1.3.5.

#### Driving without seat belt

The OBP monitors seat belts usage . Occurrences of the driver not using the seat belt shall be treated and recorded as events, along with % time without belt. An audible reminder icon will be included.

#### Following too close

The OBP shall detect and record occurrences of tailgating, which shall be defined as a set of criteria involving following distance, calculated safe following distance, and their relationship over a time segment. Tailgating events result from monitoring requirements..

#### Hard-braking events

The OBP shall detect and record occurrences of hard-breaking events. Hard-breaking events occur when break pressure exceeds a threshold to be determined.



#### Hard-steering events

The OBP shall detect and record occurrences of hard-steering events. Hard-steering events occur when steering angle variations exceed a threshold to be determined.

#### Non-signalized turns

The OBP shall detect and record non-signalized turns.

#### Speeding (speed limit violation)

The OBP shall detect occurrences of speed limit violation.

#### Speeding with respect to road curvature and road surface conditions

The OBP shall detect occurrences speed unsafe given road curvature and surface conditions.

#### Stop signs violations

The OBP shall detect and record stop sign violations based on the following inputs:

- Truck location and roadway map, provided by a GPS / GIS system
- Truck speed

A set of criteria involving these parameters shall define a threshold that indicates an event occurrence. While this was not implemented in the prototype, this is targeted for the FOT vehicles.

#### Initial failure to adjust mirrors

The OBP shall detect occurrences of a failure to adjust mirrors when starting the vehicle.

#### Excessive lateral acceleration

The OBP shall detect occurrences of unsafe excessive lateral acceleration.

#### Fatigue

The OBP shall detect occurrences of evidence of driver fatigue

### Lane departures

The OBP shall detect occurrences of lane departures

### Eyes-Off-The-Road

The OBP shall detect occurrences of evidence of drivers taking their eyes off the road in front of them.

### Failures to check blind spots

The OBP shall detect occurrences of drivers failing to check blind spots before changing lanes or making turns

### Forward collision threats

The OBP shall detect threats of collisions involving the truck and the vehicle in front of the truck.

#### *C.4.5 Feedback notices*

The OBP shall deliver feedback notices in response to the following events.

- Speeding
- Following too close
- Driving over the legal maximum number of hours
- Driving without seat belt
- Other feedback as present on the COTS devices used.

The OBP shall be programmed with specific feedback procedures that feed into a display, Digital Sound Processor (DSP) or other feedback indicator for each of these events.

#### *C.4.6 Interface control*

The OBP shall control an on-board Liquid Crystals Display (LCD) and a DSP to provide information to the driver, such as:

- System state and diagnostics FOT
- Feedback notices

#### *C.5 Performance and environmental requirements*

The OBP shall perform reliably and swiftly, allowing timely feedback notices. In particular, the OBP processing power shall be sufficient to handle the multiple inputs and processes required by its functionalities. Specific TPMs will be developed as part of the FOT.

#### *C.6 Interfaces and material requirements*

##### *C.6.1 Data interfaces*

The OBP shall feature data interface ports to connect to the truck's J-Bus as well as to individual COTS if required.

##### *C.6.2 Physical interface*

The OBP shall be contained in a reasonably size form factor that is easily mounted on-board the truck with the appropriate mounts and cables.

##### *C.6.3 Material requirements*

The OBP shall be hosted by a PC computing platform that includes the following components:

- Baseboard
- CPU and fan
- Memory
- Power supply

- Connectors and cable kit
- Case (NEMA enclosure)
- Case Fans
- Case shock mounts

The PC platform shall be completed with the following extensions:

- MPEG encoder (2)
- Serial expansion board
- Analog I/O board
- CAN card
- System hard drive (see section 2.5)
- PCMCIA slot board
- WiFi card and antenna

### *C.7 Input sensor requirements*

This section lists all sensors known to be required by the system. There is one sub-section for each sensor, which combines functional, performance and interface requirements unless otherwise specified. In general:

*COTS components shall be selected on the basis of performance / cost ratio and be positioned as industry standards in their product class, unless otherwise specified.*

Input sensors acquire information about the environment and feed data into the OBP. As such, all input sensors need to interface to the OBP. This is done in 2 ways:

- The sensor outputs data to the J-Bus, which enables acquisition by the OBP
- A direct data link is established between the sensor and the OBP

In the latter case, the nature of the hardware data link between the sensor and the OBP shall be specified. Another consideration is whether the data transfer protocol is “push” (sensor sending data) or “pull” (OBP querying data).

Data requirements for each sensor are guided by two dimensions: 1) the output unit and 2) the sampling rate.

### *C.8 Accelerometer*

The accelerometer shall sense the longitudinal acceleration rate of the truck.

OBP interface:	J-Bus
Output:	m.s <sup>-2</sup>
Sampling rate:	1 Hz

### *C.9 EOBR (HOS)*

The EOBR shall acquire driver identification and track hours of service. Driver identification may be a functionality of the EOBR system or may be provided by a separate COTS identification reader that feeds into the EOBR.

OBP interface:	TBD
Output:	min, Driver ID
Sampling rate:	1/60 Hz

### *C.10 Front collision warning system*

The front collision warning system shall be a radar-based system that detects forward collision threats. The system shall deliver a warning to the driver when such a threat is imminent.

The system also provides the distance between the truck and the leading vehicle on a continuous basis.

Output: meters, activation  
events

Sampling rate: 10 Hz

### *C.11 GIS roadway map*

The GIS roadway map is a geographical database of roadway geometry and traffic rules and signs.

Output: Curvature:  $m^{-1}$   
Speed limit: mph  
Distance to stop sign:  
m

Sampling rate: 1 Hz

### *C.12 GPS receiver*

The GPS receiver shall acquire the truck's absolute position on a second by second basis. A GPS antenna shall be integrated with the receiver.

Output: Lat, Long, HH:mm:ss

Sampling rate: 1 Hz

### *C.13 Lane departure warning system*

The lane departure warning system shall be a video-based system that detects unintended or non-signalized lane changes by correlating the truck's position relative to lane delineators, the truck speed, and signal turn use. The lane departure warning system shall deliver a warning when such lane changes occur.

#### *C.14 Outward video camera*

The outward video camera shall capture video footage on the roadway immediately ahead of the truck on a continuous basis. Images shall have a resolution of at least 320 x 240 at 30 frames per second in color.

Output: NTSC video

Sampling rate: 30 Hz

#### *C.15 Road surface conditions sensor*

The road surface conditions sensor shall be an infrared system that uses spectrographic techniques to detect road surface conditions such as:

- Dry road
- Wet road
- Icy road
- Fog over the road
- Snow on the road

Output: Index variable

Sampling rate: 1/10 Hz

#### *C.16 Rollover stability advisor*

The rollover stability advisor shall sense lateral acceleration and detect excessive curve velocity that puts the truck at risk of rolling over. The rollover stability advisor shall deliver warnings accordingly.

Output: Danger event

Sampling rate: N/A

*C.17 Side collision warning system*

The side collision warning system is a radar-based system that shall monitor the presence of other vehicles to the immediate sides of the truck. The side collision warning system shall deliver warnings to alert the driver of the presence of vehicles in the truck blind spot when the turn signal is activated.

Output: Danger event

Sampling rate: N/A

*C.18 Steering angle sensor*

The steering angle sensor shall sense the angle that is applied to the steering wheel.

Output: degrees

Sampling rate: 10 Hz

*C.19 Thermometer*

The thermometer shall sense external temperature.

Output: F

Sampling rate: 1/60 Hz

*C.20 Throttle angle sensor*

The throttle angle sensor shall sense the angle that is applied to the throttle pedal.

Output: degrees

Sampling rate: 10 Hz

*C.21 Wheel speedometer*

The wheel speedometer shall acquire truck speed by counting wheel turns.



Output: Mph

Sampling rate: 1 Hz

#### *C.22 Wiper usage sensor*

The wiper usage sensor shall sense the activation of windshield wipers.

Output: Dummy variable  
(on/off)

Sampling rate: 1/10 Hz

#### *C.23 Driver interfaces*

Driver interfaces shall comprise the following components:

- A driver identification system
- A video device providing visual feedback and notices
- An audio device providing audible notices
- Warning signals provided by some of the COTS

#### *C.24 Driver identification system*

The driver identification system shall perform reliable, secure and continuous identification of the current driver based on a personal smart card or access code.

#### *C.25 Video feedback device*

The video feedback device shall be an LCD screen that is placed on the dashboard. The video feedback device shall provide the driver with essential system information generated by the OBP such as:

- System states and diagnostics
- Visual safety notices
- Meaningful event notices and parameter values

### *C.26 Audio feedback device*

The audio feedback device shall be a combination of DSP and speaker. The audio feedback device shall deliver audible safety notices to the driver.

### *C.27 Data storage*

#### *Functional requirements*

On-board data storage shall be a hard drive or flash memory that is accessed by the OBP to write and read recorded parameters and events.

In order to allow transfers to the back-office systems, on-board system memory shall be portable. This could be achieved by using a movable, portable memory device, or by enabling download from the OBP via a physical port or a wireless link.

### *C.28 Performance requirements*

#### *Capacity*

The data storage device shall store up to 30 days worth of driving parameters and events.

#### *Reliability*

The data storage device shall observe the following requirements in order to withstand the operational environment:

- The data storage devices shall have less than 1% memory damage during the system life cycle. FOT
- The data storage devices shall tolerate shocks up to 30g. CON

### *C.29 Analysis module*

The analysis module is a PC program that is used in the fleet dispatch to read and interpret the data logged by the on-board sub-systems.

### *Functional requirements*

The analysis module shall comprise the following components:

- A secure database to host records from multiple drivers on a fleet **FOT**
- An upload processor that reads and processes raw data from the on-board data storage
- A report generator that queries and formats data into comprehensive, printable reports **FOT**
- A Graphical User Interface (GUI) **COM**

### *Database* **FOT**

The database shall be designed to host data generated by the OBP. The database may not need to store raw data for all records.

### *Upload*

The upload process shall read data from the on-board data storage, process it, and insert it into the database.

The upload process shall be fast and efficient.

### *Report generator* **FOT**

The report generator shall retrieve data from the database according to preset functional requirements. Data shall be retrieved into reports that can be viewed on a computer screen or printed as fully formatted documents.

The query engine shall be expandable to allow users to develop new types of reports.

### *Graphical User Interface* **COM**

The analysis module GUI shall be simple and user-friendly. It shall provide direct access to the main functionalities of the analysis module:

- New data upload

- Running preset report
- Querying data
- Administrative functions

#### *Material requirements*

The material requirements for the analysis module are a modern PC with enough processing power, memory and hard drive storage.

Optionally, the analysis module may be installed on a network server. In this configuration, multiple clients may run the GUI and report engine, simultaneously accessing the database.

#### *Performance requirements*

The following TPMs may be used to measure the performance of the analysis module:

##### *Data storage*

Data storage shall be measured in GB but, more importantly, typical amounts of data collected during drives should be used to express requirements in terms of vehicle-hours traveled (VHT).

##### *Processing speed*

Processing speed shall be measured for both data upload and data queries. Speed shall be measured in seconds, as a function of the volume of data being uploaded or queried.

##### *Human factors*

The GUI shall be easy to use, which shall be measured by the average time dispatchers require to master the most essential functionalities. [COM](#)