

UC Berkeley

Center for Law, Energy & the Environment

Title

A Path Forward: Identifying Least-Conflict Solar PV Development in California's San Joaquin Valley

Permalink

<https://escholarship.org/uc/item/543174qd>

Authors

Pearce, Dustin
Strittholt, James
Watt, Terry
[et al.](#)

Publication Date

2016-05-01

A PATH FORWARD

Identifying Least-Conflict
Solar PV Development
in California's San
Joaquin Valley

MAY 2016

BerkeleyLaw
UNIVERSITY OF CALIFORNIA

Center for Law, Energy &
the Environment





Authorship

The primary authors of this report are:

Dustin Pearce, Conservation Biology Institute, Goleta, CA
James Strittholt, Conservation Biology Institute, Corvallis, OR
Terry Watt, Terrell Watt Planning Consultants, San Francisco, CA
Ethan N. Elkind, Center for Law, Energy & the Environment (CLEE), University of California, UC Berkeley School of Law, CA

Additional contributions were provided by Jim Bartridge (Senior Transmission Program Specialist, California Energy Commission), Thomas Gates (Supervisor, Cultural Resources, California Energy Commission), Gabriel Roark (Energy Analyst, Cultural Resources, California Energy Commission), Jeffrey Billinton (Manager, Regional Transmission-North, California Independent System Operator [CAISO]), Steve Chung (Navy Region Southwest [NRSW] Regional Community Plans Liaison Officer [CPLO]), Daniel Gergely Szabo (Researcher, UC Berkeley School of Law) and Patrick Mealoy (Strategic Resource Advisors LLC).

Acknowledgements

The authors and organizers are grateful to both the Energy Foundation and Hewlett Foundation for their support for the convenings and policy paper. We would specifically like to thank Katie McCormack for her commitment to this work. Generous donations and grants from Granville Homes, Maricopa Orchards, Westlands Solar Park LLC, Duke-American Transmission Co., Pacific Gas and Electric Company, The Nature Conservancy, Natural Resources Defense Council (Ralph Cavanagh and Carl Zichella), and Southern California Edison matched this foundation support.

We are also grateful for the in-kind assistance from the Governor's Office of Planning and Research, California Energy Commission, and California Independent System Operator, as well as project development help from Steve Black.

Report design by Claire Hermann. Photos are courtesy of Green Energy Futures, David Dodge, Samuel Huckins, Mike Trimble, Daniel Arndt, Steve Sullivan, brotherlywalks, Morning Calm Weekly Newspaper Installation, and Jared Zimmerman.

Finally, we thank the numerous stakeholder group representatives (listed by their groups throughout the report and listed after the conclusion) for their dedication to and support for this project.



EXECUTIVE SUMMARY

The San Joaquin Valley (“Valley”) is positioned to play a pivotal role in helping California achieve its ambitious goal to meet half of the state’s electricity demand by 2030 from renewable sources. The Valley’s temperate climate and high solar insolation has already attracted investment in over 120 solar energy facilities, which are either already operating or in the planning stages. These facilities average approximately 500 acres in size and generate 67 megawatts in energy -- enough to power 16,750 homes each. They illustrate the potential for the Valley to be a major contributor to the state’s renewable energy portfolio. However, the Valley is also home to some of the richest, most productive farmland in the world while containing some of our most imperiled plants, animals and natural habitats. As a result, identifying good locations for solar projects can entail significant controversy.

To help reduce land-use conflicts associated with solar siting, Conservation Biology Institute (CBI), Berkeley Law’s Center for Law, Energy and the Environment (CLEE), and Terrell Watt Planning Associates, with input from the Governor’s Office of Planning and Research (OPR) (collectively the “project team”), undertook a stakeholder-led process, called the “Solar and the San Joaquin Valley Identification of Least-Conflict Lands Project.” Initiated in June 2015, the goal was to explore how multiple and diverse parties could quickly (within six months) identify least-conflict lands for solar photovoltaic (“solar PV”) development from their perspectives. This document describes the process and summarizes the key findings and recommendations.

“We set out to show that multiple and disparate parties could identify least-conflict areas for siting of solar projects in the San Joaquin Valley in a matter of months rather than years, for a reasonable cost, and that the maps could help streamline siting of projects. This approach works. It is now incumbent upon us to take advantage of it.”

- Ken Alex, Senior Advisor to Governor Jerry Brown and Director of the Governor’s Office of Planning and Research

In sum, the team identified 470,000 acres of least-conflict land, amounting to roughly 5% of the 9.5 million acres in the stakeholder study area.

The process included utilizing advanced mapping software to generate a series of stakeholder group maps that identified their highest- and lowest-priority areas. Ultimately, by combining the results of each stakeholder group's mapping exercises, the project team could identify composite least-conflict areas. In sum, the team identified 470,000 acres of least-conflict land, amounting to roughly 5% of the 9.5 million acres in the stakeholder study area.

The report identifies challenges to solar PV development in the Valley on least-conflict lands, as well as potential solutions, some of which were already in discussion for adoption. Most prominently, stakeholders were virtually unanimous in their identification of the lack of adequate transmission serving the Valley as the single largest challenge to unlocking the region's solar potential in a way that would minimize impact on sensitive lands.

Readers should note that the results represent a snapshot in time and do not predict how drought or other changing conditions in the Valley could alter the landscapes identified in this exercise. They are also combined rather than consensus results. Notably, the project process does not remove areas from solar PV development or bind decision-makers in any way.

This first-of-its-kind effort includes the identification of a credible amount of land as least-conflict using a composite approach, with clear articulation of the challenges facing project implementation and a path forward for both stimulating needed conversations and driving accelerated decision-making around transmission and other planning. That process could include quicker project approvals and advancements in the local and bulk transmission system serving targeted areas.

The stakeholder work utilized the Data Basin San Joaquin Valley Gateway (www.sjvp.databasin.org), a web-based resource that supported the stakeholder groups with their mapping exercises. All of the datasets and model results will remain in the gateway. The project findings can therefore be updated to reflect new information, used to inform ongoing conversations in a variety of stakeholder and decision-maker forums (such as local planning efforts, the state's Integrated Energy Policy Report, and Renewable Energy Transmission Initiative), and potentially replicated in other regions.



INTRODUCTION

Project Background

California is committed to meeting half of its electricity demand by 2030 from renewable sources. In 2015, the California Legislature approved and Governor Brown signed SB 350 (De Leon, Chapter 547, Statutes of 2015), which mandated that 50 percent of the state's electricity usage come from sources such as solar, wind, geothermal, and biomass.¹ To fulfill this mandate, renewable energy advocates and companies continue to explore opportunities for renewable energy development throughout the state, with a large focus on solar photovoltaic ("solar PV") development in the San Joaquin Valley (the "Valley"). This solar technology has experienced dramatic cost decreases in the past half-decade, while renewable developers view the Valley as an opportunity area for solar PV due to its abundant sunshine, geographic proximity to demand and existing transmission, and large parcels of developable land.

Adding to California's renewable energy and greenhouse gas (GHG) emissions reduction goals, the federal government renewed the Investment Tax Credit (ITC) in 2015, which will likely contribute to a renewed solar PV development boom that could continue through the next five years.² Given the speed and scale of renewable energy development needed in California, as well as the sweeping changes in the energy landscape that will be required to meet the renewable and GHG goals, solar PV will play a crucial role in the energy future of both California and the Valley.

With this impending boom, numerous residents and interested parties express concern over the potential impacts that solar PV projects may have on agricultural and ranching lands, as well as on sensitive and unique native species and natural habitats. The Valley is one of the most productive agricultural areas in the world; yet it continues to see losses of farmland to traditional development. Meanwhile, the recent historic drought has forced farmers to fallow hundreds of thousands of acres.³ Similarly, rangeland areas supporting natural vegetation, wildlife, and cattle have

seen significant negative consequences from the drought. The remaining highly fragmented natural areas of the Valley cover only 30 percent of their historical extent and persist mainly in the foothills of the Sierras and coastal ranges.⁴

In order to protect the Valley's remaining natural resources, many conservation organizations have advocated for "smart from the start" renewable energy development planning that encourages developers to locate projects in areas with low environmental value and in proximity to existing transmission corridors.⁵ Likewise, agricultural interests have advocated development only on lands that are no longer agriculturally productive. State and local policy makers and renewable developers will need to balance these conservation and agricultural interests with the important role solar energy plays in combating climate change and meeting California's renewable energy goals. Because of the nexus between solar development, farming, ranching, and concerns for the remaining natural systems in the region, the San Joaquin Valley provides an excellent location where proactive landscape-level planning is critically needed and can yield important benefits to all interests.

The overarching objective was to answer this single question:

Where are least-conflict lands in the San Joaquin Valley for solar PV development?

To address the multiple needs and values within the Valley, Ken Alex, Senior Advisor to Governor Brown and Director of the Governor's Office of Planning and Research (OPR), urged the completion of a stakeholder-led, landscape-scale planning process to identify "least-conflict" lands for solar PV development in the Valley from the perspective of each stakeholder group. The effort would also provide direction to policy makers for eliminating barriers to siting projects on identified areas. A public-private partnership was created to support the planning effort, with project team leads Conservation Biology Institute (CBI), UC Berkeley Law's Center for Law, Energy and the Environment (CLEE), and Terrell Watt Planning Associates, along with input from OPR.

The overarching objective was to answer this single question: ***Where are least-conflict lands in the San Joaquin Valley for solar PV development?***

The project team leaders of this process worked with stakeholders to provide direction to policy makers through key recommendations, while fostering knowledge sharing and collaboration among participants throughout. Ultimately, the San Joaquin Valley least-conflict area information was developed through a collaborative, stakeholder-driven planning process intended to identify and recommend least-conflict areas in the Valley where solar PV development could reduce siting conflicts and facilitate timely project construction. The collaborative planning process was non-regulatory and informational only, and the results do not legally restrict solar PV project development to specific areas in the San Joaquin Valley. This process was, and remains, a non-binding, non-regulatory planning effort.

The collaborative planning process was non-regulatory and informational only, and the results do not legally restrict solar PV project development to specific areas in the San Joaquin Valley.

The Process

In order to identify least-conflict lands through a “Planning 101” exercise, the project team convened four stakeholder groups early in the process: (1) environmental conservation, (2) agricultural farmland conservation, (3) solar industry, and (4) transmission groups. The project team added the agricultural rangeland stakeholder group during the course of the process to gain a better understanding of regional land value from this stakeholder perspective. Project leaders conducted outreach to military representatives and tribal governments to understand their concerns regarding future development in the region. To aid the stakeholder groups, state and federal agency advisors provided data, advice, and technical assistance. The support team worked closely with each group individually to prepare their contribution to the objective and convened all parties in face-to-face meetings at important milestones in the process to allow for sharing and learning.

Stakeholders managed their work using a powerful online mapping platform – the San Joaquin Valley Gateway (the “Gateway” at www.sjvp.databasin.org) supported by Data Basin. The Gateway is accessible using common web browsing software and has supported the upload and aggregation of relevant spatial datasets regardless of the source. It allowed for each group to work in private as needed; provided tools to maximize data and model transparency; allowed for the ability to share content throughout the process; and provided a durable site for ongoing work in the future. In addition to providing the Gateway, CBI and the project team managed meeting times, technical modeling efforts, and information gathering as needed for the stakeholder groups.

The project team made the final outputs from each stakeholder working group available publicly on the Gateway, with a single goal in mind: identifying potential areas for solar PV development in the Valley that each stakeholder group viewed as least-conflict. In order to accommodate the groups’ different needs, each group approached the exercise with diverse methods and outputs. The solar industry stakeholder group identified opportunity areas within the Valley, while the agricultural farmland and environmental conservation stakeholders identified spatially explicit least-conflict lands. The agricultural rangeland stakeholder group and military representatives provided spatial information to add context for other stakeholders but did not identify least-conflict lands in the region. The project team generated the final result (the composite least-conflict area) using the information developed with the solar industry, environmental conservation, and agricultural farmland conservation stakeholder groups. The team then shared the composite least-conflict area information with 28 tribes that have cultural affiliation to some portion of the Valley planning area.⁶

The project team created models and maps based on the best available data identified and used by each stakeholder group at the time. *Recognizing that new information and conditions on the ground for decision making are constantly changing, the project team will need to update the outputs generated from this work to keep them relevant to the objective addressed.* Additionally, the results could change once incomplete or inadequate data get supplemented. Retaining the work from each of the groups on the Gateway will provide the means to make adjustments as conditions change and new data and information become available. The creation of the outputs by each stakeholder group represents work that should therefore be maintained, updated, and enhanced in years to come. Notably, because of confidentiality restrictions, sensitive geographic information received directly from tribal governments is neither available on the Gateway nor presented in this report. In addition, identification of least-conflict lands via this process does not preclude development of solar PV where local and county governments find them to be suitable. This process intended to demonstrate that by bringing stakeholders together, identification of least-conflict lands could serve as initial information to help direct development in a more streamlined fashion to minimize the environmental, social, and political risk. As emphasized, all results from this exercise are snapshots in time that will undoubtedly change as more information becomes available and knowledge is gathered from the life cycle of developed solar PV, including construction, operation impacts, and decommissioning.

Outcome

This first of its kind, short-term exercise produced least-conflict maps for each stakeholder group that led to a final composite map. The process and the supporting platform proved nimble in supporting new data, models, and stakeholder working groups as the process unfolded, expanding and improving the final products. For example, the formation of the rangeland stakeholder group and the provision of information from the military and tribal governments occurred after the initial project launch.

For the first time, stakeholders were able to create maps revealing least-conflict lands from their perspectives with the underlying logic, data, and information available for review. All work completed by the stakeholders will remain on the Gateway to inform other planning processes and will be available for updating over time to reflect changing conditions. This process empowered the stakeholder groups and leveraged their knowledge through collaboration.

Many stakeholders expressed interest in reconvening to update the work in the future when more is known about the status of agricultural water supply and solar PV development impacts on the landscape. Another consistent theme echoed in the stakeholder process was that there is inadequate transmission capacity in the Valley to accommodate all the potential least-conflict renewable opportunity. Identification of these lands will be for naught without enough transmission on the ground to bring the renewable energy generated to the marketplace. Future meeting dates and

convenings could launch a discussion around issues this planning process identified but had inadequate time to fully address, such as additional cross-stakeholder group discussions, consensus building, and further recommendations for policy makers.

San Joaquin Valley Gateway

The San Joaquin Valley Gateway (www.sjcp.databasin.org) is a customized, map-based data sharing and collaboration platform based on Data Basin technology developed by the Conservation Biology Institute. The core of Data Basin is free to visitors and provides open access to thousands of scientifically grounded, biological, physical, and socio-economic datasets. This user-friendly platform enables people with varying levels of technical expertise to:

- Integrate a wide range of data into a single location
- Explore and organize the data and Information in new ways
- Organize non-spatial information and documentation
- Obtain high levels of transparency regarding all system content
- Publish or produce new datasets and maps
- Work together in self-organizing groups

To support the process to define least-conflict lands for solar development, the project team aggregated over 600 individual datasets into the Gateway and organized them into meaningful folders (called galleries) for easy access and use by the stakeholders (Figure 1). Having governmental and non-governmental datasets organized into a single location (with some important datasets contributed by the stakeholders themselves) proved powerful.

In a few cases, the project team created or compiled new datasets (e.g., current solar facilities) to fill some important gaps; others gaps remain unfilled (e.g., water availability forecasts). The acquired data ranged from basic spatial information (e.g., infrastructure and current land use) to more complex model results (e.g., potential species distributions). In fact, two of the stakeholder groups used numerous datasets to produce their

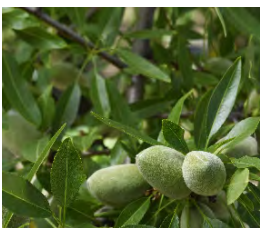

San Joaquin Valley -
Farmland Conservation



San Joaquin Valley -
Environmental Conservation



San Joaquin Valley - Energy



San Joaquin Valley -
Rangeland Conservation



San Joaquin Least Conflict
Solar Agricultural Farmland
Model

FIGURE 1. Example galleries created for the least conflict solar project. Each one contains numerous spatial datasets relevant to the topic identified in the headings.

own spatial model to identify least-conflict lands from their individual perspectives. The system allowed the groups to understand the input data better and how each component influenced the final result. It also provided the means to share it with and explain it to other stakeholders. All of the data used or generated from the process can be obtained on the gateway, where it will remain in the foreseeable future. It can be used to further refine results and support the discussion for this topic as well as to address other planning and resource issues affecting the same geography.

The platform was also instrumental in supporting three facilitated convenings, during which time the stakeholders could review key datasets together as a group and discuss them. This functionality in a group discussion helped to clarify for attendees the value and limitations of the available data to support the exercise while also illuminating important data gaps.

The platform allowed the stakeholders to work together in their respective groups to develop their results and, later in the process, the groups used the platform in real-time during the meetings to share individual results with the other stakeholders.



SOLAR INDUSTRY STAKEHOLDER MAPPING

Since climate change poses such a serious global threat, California has made rapid development of renewable energy sources a critical strategy in its effort to reduce greenhouse gas emissions. Solar PV has seen significant increases in deployment and cost reductions over the past few years, compared with other solar technologies. This has led to significant development of solar PV in nearly all areas of California. Of all new renewable energy generation capacity added in California in 2015, 80 percent came from solar PV.⁷ In 2016, nearly 100 percent of new renewable energy generation capacity in California may come from solar PV development.⁸ Therefore, with significant growth expected from solar PV over the next few years, decision-makers and other stakeholders must be proactive in siting and planning solar PV technologies in California.

The state currently has 8.7 gigawatts of solar PV capacity, with 3.5 gigawatts self-generated.⁹ Recently, the U.S. Energy Information Administration predicted that 4.1 gigawatts of new utility-scale solar capacity will be built in California by the end of 2017.¹⁰ This would represent 50 percent more than the current capacity and would necessitate the development of approximately 25,000 additional acres.^{11,12} Accommodating this growth will therefore require proactive planning, continued discussion around solar compatibility, and the integration of new planning techniques to continue to reduce soft costs.¹³

Mapping Process

The solar industry group, which consisted of 30 members from solar development companies and industry associations, directed CBI staff to develop an “opportunity area” for the San Joaquin Valley. The area consisted of a solar stakeholder boundary and protected areas. Inputs for mapping were based upon physical features of the landscape and regulatory boundaries. Results were generated for the eight San Joaquin Valley (SVJ) counties: Kern, Kings, Tulare, Fresno, Madera, Merced, Stanislaus, and San



Source Data

1. California Digital Elevation Model - National Aeronautics and Space Administration (NASA) and the National Geospatial-Intelligence Agency (NGA), 2000¹⁴
2. PAD-US (CBI Edition) Version 2.1, California¹⁵
3. California Conservation Easements – Green Info Network, 2015¹⁶
4. Critical Habitat – United States Fish and Wildlife Service¹⁷
5. California Department of Fish and Wildlife, 2013¹⁸

Joaquin – with all areas in the Desert Renewable Energy Conservation Plan in Kern County removed. The data used to develop the opportunity area included a digital elevation dataset, county boundaries, and protected lands datasets within the Valley. Importantly, this mapping does not preclude any solar developer from going outside the solar stakeholder boundary or developing within any areas that have not been identified by the other stakeholder groups as least conflict.

All review and decisions among the group were done through online conference meetings using the Gateway. During initial development of the solar stakeholder boundary and protected areas, the group held weekly meetings to cover current progress of the mapping, with final adjustments made early in the planning process. This opportunity mapping approach was ultimately integral in combining outputs from the other stakeholder groups. This work was therefore foundational for the rest of the mapping done by other groups, allowing for a defined solar industry primary area of interest – the solar stakeholder boundary – against which the other results were compared.

Data Development

Starting with a 90-meter digital elevation model (DEM), visual inspection revealed a rough estimate of 220 meters of elevation as a starting point to create a boundary for the solar opportunity area. The DEM was converted to contour lines using a contour tool in GIS. A 5-kilometer buffer of the 220-meter contour line defined the primary focal area from the perspective of the solar group, although areas outside this boundary may still be of potential interest.

This initial solar stakeholder boundary was enlarged in areas to the south to include low sloping areas where solar development previously occurred near Avenal in Kings County and Blackwells Corner in Kern County. No boundary edits were necessary along the eastern section of the Valley. To finalize the boundary, all areas outside of the Valley county boundaries were eliminated. Areas removed were primarily in the northern counties of Madera, Merced, Stanislaus, and San Joaquin. After discussion with the solar industry stakeholder group, the areas that were identified in their mapping as “protected areas” were all Gap Status 1 and 2 fee lands,¹⁹ federally designated critical habitat for endangered species, conservation easements, and lands owned and operated by the California Department of Fish and Wildlife. All areas that are within the solar stakeholder boundary and outside identified protected areas constitute the solar development opportunity area.

Solar Industry Mapping Results

The solar stakeholder mapping exercise found opportunity areas in all eight Valley counties (Figure 2). The opportunity area shown is exclusively on the valley floor, excluding higher elevation areas and areas with stringent development restrictions (including protected lands and areas unlikely to be streamlined for solar development, such as federally designated critical habitat). Total acreage identified within the solar stakeholder boundary was

9,535,267 acres, while the total area screened out by the solar stakeholder group was 1,009,440 acres (10.6 percent).

Solar Industry Stakeholder Participants

*Companies/Entities Listed in Alphabetical Order

8 Minute Energy
Clenera Energy
Crowell and Moring LLP
EON
ES Law
First Solar
Granville Homes
Iberdrola Energy
Independent Consultant Firms
Large-scale Solar Association
Maricopa Orchards
Next Era Energy
NRG
Paul Hastings
PV2 Energy
Recurrent Energy
Strategic Resource Advisors
SunEdison
Sun Power
Westlands Solar Park

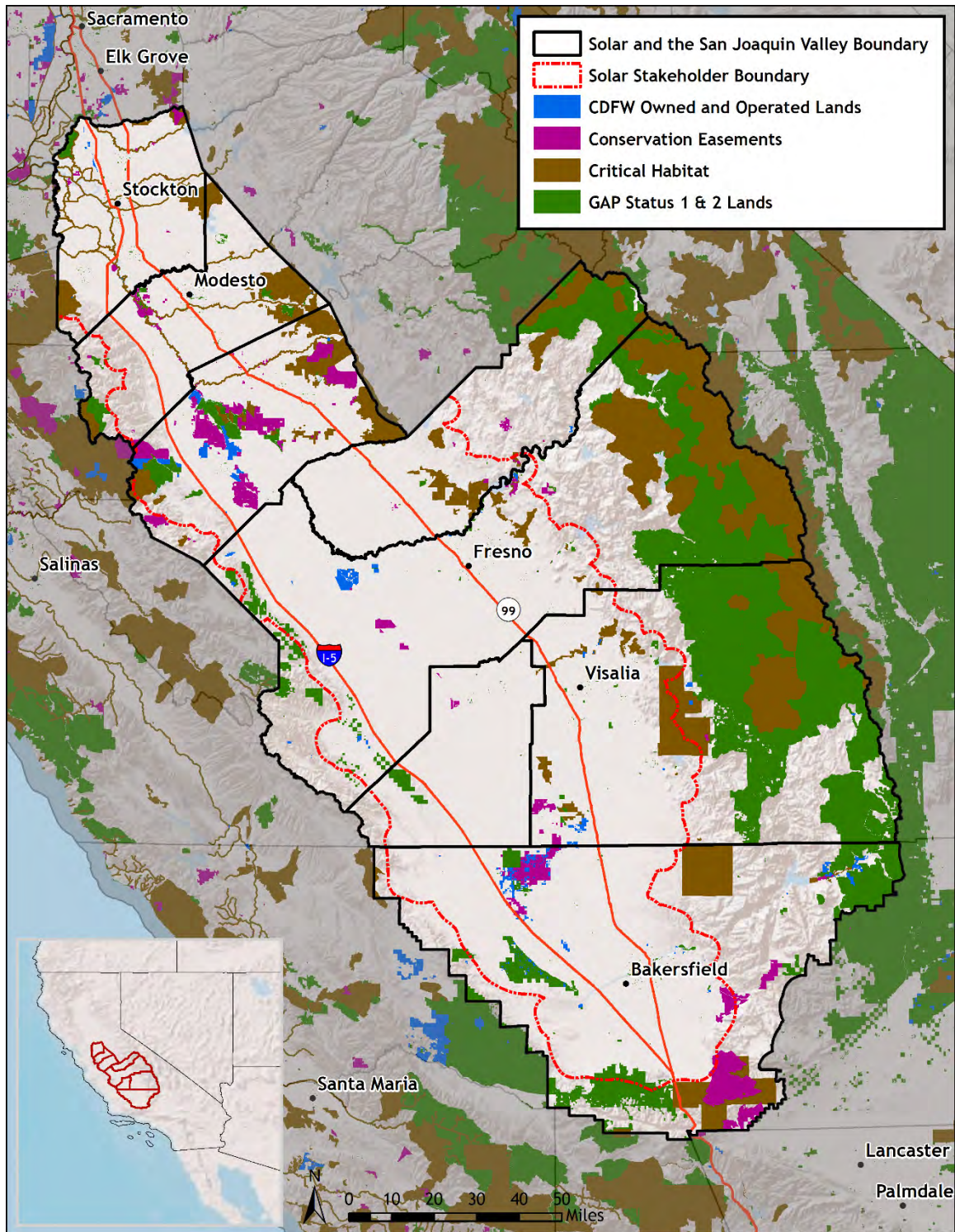

FIGURE 2. Final solar stakeholder output showing opportunity and avoidance areas. All areas within the solar stakeholder boundary (red dashed line) that are not covered by another land classification represent the solar stakeholder opportunity area. All polygons shown within the solar stakeholder boundary are areas that are considered unlikely for solar development.



AGRICULTURAL FARMLAND STAKEHOLDER MAPPING

The San Joaquin Valley is one of California's largest and most important agricultural regions. All 8 counties of the Valley rank within the top 10 list for agricultural market value within California, with 7 of the 8 counties on the top 10 list nationally.²⁰ Its farms and ranches account for more than 70 percent of the state's total annual agricultural production value of \$53+ billion. Much of this value is from the production of more than 300 different crops that thrive in the region's Mediterranean climate. California produces 2/3 of the nation's fruits and nuts and over 1/3 of the nation's vegetables, with the Valley supporting this production at a national and a global scale.

Federal and state water projects allow irrigated crop production year round in this region of California.²¹ Abundant groundwater resources, high soil productivity, numerous microclimates, and a culture developed around agriculture all make this region an area where long-term crop production and ranching will remain a top priority. Tax incentives such as the Williamson Act support the protection of farmland and conservation of rangeland at the county level.²² This protection was developed in parallel with efforts to track changing land use and conversion of agricultural lands through the Farmland Monitoring and Mapping Program (FMMP), which has documented 1.4 million acres of agricultural land conversion since it began recordkeeping in 1984.²³ Solar development, like other development within the region, represents a change on the Valley floor that needs to be weighed against the long-term capabilities of the land for food production.

Mapping Process

The agricultural farmland stakeholder group, which consisted of 24 members from non-profits, agricultural organizations, and consulting firms, directed CBI staff to develop an agricultural model to identify least-conflict lands for utility-scale solar development from an agricultural crop production perspective. Agency staff provided assistance with data issues as needed. Generation of the farmland model included multiple iterations and consisted of a series of screens for identifying different categories of farmland importance, with the main emphasis on identifying least-conflict lands.

This model focused on all or portions of the eight San Joaquin Valley counties - Kern, Kings, Tulare, Fresno, Madera, Merced, Stanislaus, and San Joaquin - encompassing 9,947,092 acres of land, after removing protected areas and urban areas from the analysis. These areas were removed to focus the mapping on active agricultural areas within the Valley. The foundation of the model consisted of the latest FMMP data and classifications; these datasets are updated at the county level biennially by the California Department of Conservation. Additional inputs to the model included soil and microclimate attributes and impaired drainage data within Westlands Water District. The group developed a final map that identified six classes of agricultural farmland value.

The question addressed by the group was: *Where are areas of least conflict for utility-scale solar development in the San Joaquin Valley from the Agricultural Farmland Stakeholder group perspective?*

The agricultural farmland group provided direction and insight to the modeling team to generate their final map. The process required frequent online meetings (weekly at first) supported by the Gateway throughout the process. Decision-making occurred through online conferencing, which allowed for nimble development and participation by all members of the group.

The model developed by the agricultural farmland conservation stakeholders used spatial datasets from federal, state and county governments. In general, inputs for the screening criteria covered current and past agricultural production potential, with priority given to lands that served multiple purposes or were of higher rarity in the San Joaquin Valley. As stakeholders acknowledged, not all lands are of equal agricultural value, and their condition is not necessarily static. The group noted that farmland condition in this region is constantly evolving due to climate change, water demands and use, changes in soil chemistry, and crop markets. As a result, identifying areas that are productive or non-productive will continue to be dynamic. Despite this constraint of the final agricultural farmland model, the logic behind the screening method remains sound, and this stakeholder group or others can easily update the model as landscape conditions continue to change.

Model Design

The project team chose a model design that was relatively straightforward and focused on overlaying the various inputs to create a final map of six different categories, from Rare Priority Agricultural Areas to Priority Least-Conflict Areas. The model diagram presented in Figure 3 illustrates how the data inputs generated the six final map classifications explained below.

Rare Priority Agricultural Areas. Areas mapped as the highest importance to the agricultural community and defined as lands identified as Prime Farmland, Farmland of Statewide Importance, or Unique Farmland according to FMMP that coincided with excellent or good Groundwater Recharge Areas **and** that also coincided with citrus crops, which are indicative of rare microclimates for these types of important crops.

The question addressed by the group was:

Where are areas of least conflict for utility-scale solar development in the San Joaquin Valley from the Agricultural Farmland Stakeholder group perspective?



Model Inputs

1. Farmland Mapping and Monitoring Program 2012 - California Department of Conservation²⁴
 - Prime Farmland, Farmland of Statewide Importance, and Unique Farmland
 - **NOT** Prime Farmland, Farmland of Statewide Importance, and Unique Farmland
2. Soil Storie Index Classification - Natural Resources Conservation Science^{25,26}
 - Poor, Very Poor, Non-Agricultural, Not Applicable for Storie Index Classes
3. Soil Salinity Classification - Natural Resources Conservation Science²
 - Moderately Saline, Strongly Saline Classes
 - Slightly Saline Class (Only in Westlands Water District)
4. Groundwater Recharge Areas - Soil Agricultural Groundwater Banking Index (SAGBI) 2015 - UC Davis²⁷
 - Excellent, Good Classes
5. United States Department of Agriculture - Cropscape CDL 2014 Data²⁸
 - Citrus Crops
6. Impaired Drainage Area - Bureau of Reclamation
 - Westlands Water District Impaired areas within the San Luis Unit Drainage

See **Appendix A** (see www.sjvp.databasin.org) for a complete listing, description, and links to the source data used in the agricultural farmland model.

Priority Agricultural Areas. Areas mapped of high importance, characterized by Prime Farmland, Farmland of Statewide Importance, or Unique Farmland according to FMMP that also coincided with excellent or good Groundwater Recharge Areas.

Important Agricultural Areas. Areas mapped as important, based on lands classified as Prime Farmland, Farmland of Statewide Importance, or Unique Farmland according to FMMP but were **NOT** also coincident with excellent or good Groundwater Recharge Areas or citrus crops.

Potential Important Agricultural Areas. Areas mapped as Prime Farmland, Farmland of Statewide Importance, or Unique Farmland according to FMMP that were also known to have impaired soils (Moderately or Strongly Saline Areas) **and** Poor, Very Poor, Non-Agricultural, or Not applicable for Storie Index Classes.

Least-Conflict Areas. Areas **NOT** mapped as Prime Farmland, Farmland of Statewide Importance, or Unique Farmland according to FMMP **or** areas that were within Westlands Water District drainage impaired lands.

Priority Least-Conflict Areas. Areas **NOT** mapped as Prime Farmland, Farmland of Statewide Importance, or Unique Farmland according to FMMP that also coincided with impaired soil areas (Moderately or Strongly Saline Areas) **and** Poor, Very Poor, Non-Agricultural, or Not applicable for Storie Index Classes, **or** areas that were within Westlands Water District drainage impaired lands that overlaid impaired soil areas (Slightly, Moderately, or Strongly Saline Areas) **and** Poor, Very Poor, Non-Agricultural, or Not applicable for Storie Index Classes.

TABLE 1. Total acres for each agricultural classification within the agricultural farmland model boundary and within the solar stakeholder focal area.

| Agricultural Classification | Acres - Within the Farmland Extent | Acres - Within the Solar Stakeholder Opportunity Area |
|--|------------------------------------|---|
| Rare Priority Agricultural Area | 121,917 | 121,874 |
| Priority Agricultural Area | 1,708,407 | 1,699,481 |
| Important Agricultural Area | 2,587,111 | 2,585,632 |
| Potential Important Agricultural Area | 405,408 | 405,408 |
| Least-Conflict Area | 4,656,203 | 2,778,123 |
| Priority Least-Conflict Area | 468,046 | 462,011 |
| Built Up Lands and Protected Areas Removed | --- | 1,482,738 |
| Total | 9,947,092 | 9,535,267 |

Agricultural Farmland Conservation Mapping Results

The agricultural farmland screening model output found areas of least-conflict throughout all eight Valley counties totaling over 3.6 million acres (37 percent) of the 9.5 million acres within the solar stakeholder focal area (Table 1). Figure 4 displays least-conflict areas as different shades of green, with the darkest green representing the “Priority Least-Conflict Areas.” These areas highlight Westlands Water District and other clusters of land along the western half of the Valley floor. Lands classified as “Least-Conflict Areas” were located primarily in the foothill regions surrounding the Valley floor. The final least-conflict category areas, “Potentially Important Agricultural Areas,” were concentrated in the central portion of the Valley.

Areas highlighted within these three categories are not currently in irrigated agriculture **or** represent areas where salt and drainage impairment occur. Some of these areas are naturally saline and/or drainage-impaired, while in other cases agricultural practices create these conditions over time. In

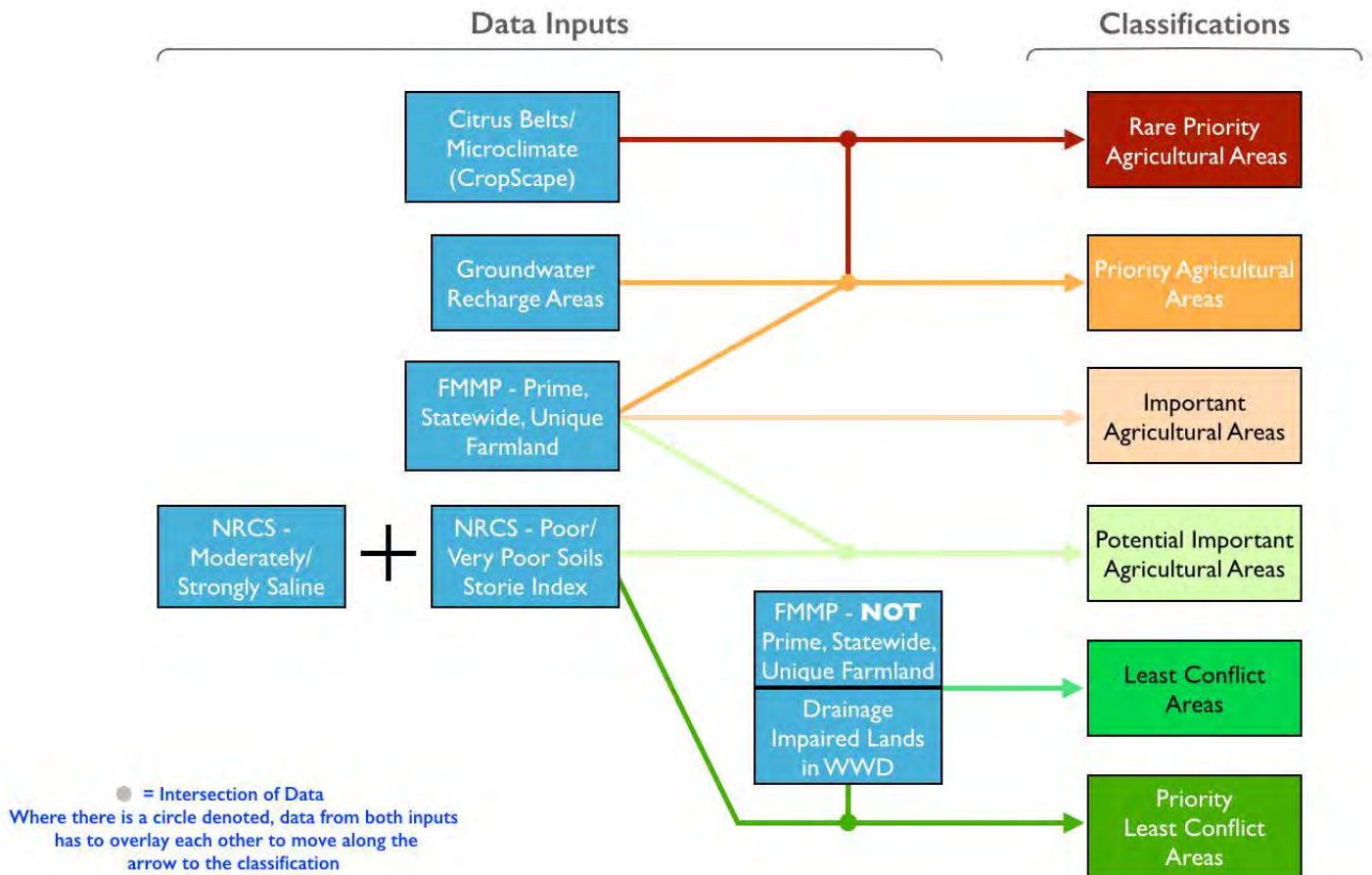

FIGURE 3. Conceptual Screening Model shown for the Agricultural Farmland Stakeholder group. Boxes shown in light blue (left) are data inputs and all other boxes shown (right) are land classifications developed by the agricultural stakeholders. [NRCS - Natural Resources Conservation Science; FMMP - Farmland Mapping and Monitoring Program; WWD - Westlands Water District]

locations where irrigation is required to grow crops (as is the case throughout much of the Valley), the act of irrigation can result in salinization of the soil, forming hard crusts on the soil surface (impairing drainage) and becoming increasingly toxic to many agricultural plants. On the Valley floor, the drainage-impaired areas in Westlands Water District and much of the areas surrounding the Tulare Lake Bed are the largest areas identified as least conflict. While these areas remain the largest contiguous areas highlighted, many clusters of smaller areas remain scattered throughout the Valley.

Agricultural Farmland Stakeholder Participants

Neema Assemi - Maricopa Orchards
Michael Boccadoro - West Coast Advisors
Michael Delbar - California Rangeland Trust
Russ Freeman - Westlands Water District
John Gamper - California Farm Bureau Federation
John Garamendi, Jr. - Professional Evaluation Group, Inc.
Sergeant Green – Fresno State University
Virginia Jameson - American Farmland Trust
Bill Martin - Central Valley Farmland Trust
Lynne McBride - California Farmers Union
Karen Mills - California Farm Bureau Federation
Mike Ming - Alliance Appraisal
Jean Okuye - Resource Conservation District
Tom Orvis - Stanislaus County Farm Bureau
Jon Reiter - Maricopa Orchards
Karen Sweet - California Rangeland Conservation Coalition
Ed Thompson – American Farmland Trust
David Zoldoske - Fresno State University

Agency Advisors

Scott Flint – California Energy Commission
John Lowrie - California Department of Conservation
Jenny Lester Moffitt - California Department of Food and Agriculture
Conor O'Brien - California Department of Food and Agriculture
Nathaniel Roth - California Geological Survey/California Department of Conservation
Robert Tse - United States Department of Food and Agriculture

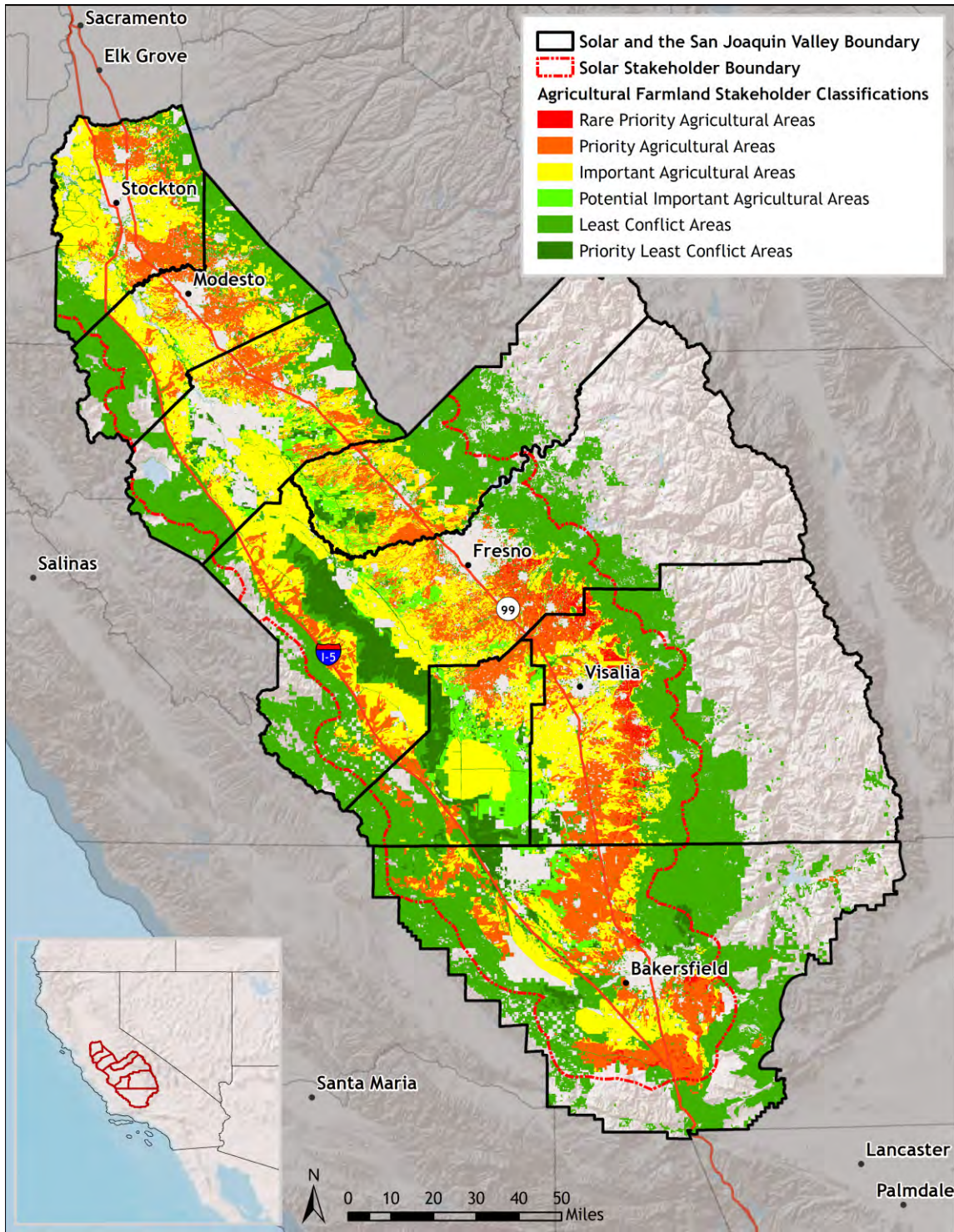

FIGURE 4. Final output for the agricultural farmland stakeholders screening model. Classifications presented for the farmland model exclude protected and built up areas (masked as light grey). Red dashed boundary depicts solar stakeholder opportunity area. Least conflict areas appear as shades of green, with the red, yellow, and orange representing areas that are not considered least conflict by the agricultural farmland group.



ENVIRONMENTAL CONSERVATION STAKEHOLDER MAPPING

The question addressed by the group was:

Where are areas of least-conflict for utility-scale solar development in the San Joaquin Valley from the Environmental Conservation group perspective?

The San Joaquin Valley is an area that has seen vast landscape-scale change since the early twentieth century.²⁹ The majority of its natural communities on the Valley floor have been reduced to less than five percent of their original extent.³⁰ Conversion of natural landscapes to human uses has reduced species movement, permanently removed and fragmented habitat, and resulted in the loss of native species' abundance and diversity. As of 2016, a total of 23 plant and animal species are listed as endangered or threatened on the Valley floor, contributing to California's record of 151 rare species (more than all other states but Hawaii).³¹

Environmental protection in the Valley has come in incremental steps focusing on restoring rivers and salmonid species in the northern counties, protecting and adding waterfowl habitat throughout the region, and protecting rangeland in the foothills.³² Balancing species and native habitat protection is a priority for this region, which lies directly within the Pacific Flyway and the California Floristic Province, one of 25 global hotspots for biodiversity.³³ Solar development, like other development within the region, represents a change on the Valley floor that needs to be weighed against the long-term impacts to globally significant native species and communities in an already highly developed and fragmented landscape.

Mapping Process

The environmental conservation stakeholder group, which consisted of 21 members from non-profits and environmental consulting firms, directed CBI staff to develop an environmental model to identify least-conflict lands for utility-scale solar development from the environmental conservation stakeholder group perspective. Generation of the environmental conservation model involved an iterative process to develop a logic structure that identified areas of important environmental concern and value, with an emphasis on identifying least-conflict lands.

The model focused on all or portions of the eight San Joaquin Valley counties - Kern, Kings, Tulare, Fresno, Madera, Merced, Stanislaus, and San



Model Inputs

1. Conservation Elements: Areas of Conservation Emphasis Version 2 (ACEIIV2) – California Department of Fish and Wildlife^{35,36}

- Sensitive Habitat Index (SENSHAB_EN)
- Rarity Weighted Richness Index (RWI_EN)
- Biological Index (BIO_IND_EN)

2. Wetland Density

- National Wetland Inventory – United States Department of Fish and Wildlife³⁷
- California Central Valley Wetlands and Riparian Classes – California Department of Fish and Wildlife³⁸

3. Vernal Pool Density

- Great Valley Vernal Pool Habitats - 2014³⁹

4. Species Distribution Models including Occurrences^{*40}

- Species Habitat Entire - Swainson's Hawk and Tricolored Blackbird occurrences included*
- Species Habitat Foothills
- Species Habitat Southwest

5. Landscape Permeability⁴¹

- Permeability for the Western United States – Theobald, 2013

6. Selected Corridors⁴²

- California Essential Connectivity (Corridors and Blocks) – California Department of Fish and Wildlife
- Fresno Slough Corridor – Patrick Huber Corridor Analysis
- Main River Corridors within the Study Area – including 500m buffer
- San Joaquin Kit Fox Permeable Land Use – Cypher and Phillips, 2013

Joaquin. In addition, the model included areas in San Benito, Monterey, San Luis Obispo, Santa Barbara, Ventura, Mariposa, Tuolumne, Calaveras, Amador, Sacramento, Contra Costa, Alameda, and Santa Clara counties. The study area for this model outside of the eight Valley counties spilled over to the north, west, and southwest to provide important context for conservation planning in the region. The total area assessed by the environmental conservation stakeholder group was 12,573,012 acres. Additionally, the study area included The Nature Conservancy's Western San Joaquin Valley Solar Assessment and the Bren School of Environmental Science and Management's study areas.³⁴ Both of these projects undertook independent analyses identifying areas of lower environmental and agricultural value that may be suitable for solar development. Including results from these previous studies allowed for a comparison of the studies. In the northern Valley counties, the project team buffered the boundary out by five kilometers to reduce any boundary effects sometimes created during modeling.

The environmental conservation stakeholder group used the Environmental Evaluation Modeling System (EEMS) framework developed by CBI to construct a logic model that considered four main components:

1. relatively intact areas that allow for movement of species and ecological process;
2. occupied or potential rare species and communities;
3. conservation lands that already prevent or restrict development such as designated conservation lands and federally designated critical habitat; and
4. conservation priority areas provided by the stakeholder group.

Based on an analytical unit of a 1km² grid cell array across the study area, the EEMS model produced a continuous output showing relative environmental conservation value for the greater San Joaquin Valley.

The question addressed by the group was: *Where are areas of least-conflict for utility-scale solar development in the San Joaquin Valley from the Environmental Conservation group perspective?*

The environmental conservation group provided direction and insight to the CBI modeling team to generate the final model and map. The process required frequent online meetings (weekly at first) supported by the Gateway throughout the process. Decision-making through online conferencing allowed for nimble development and participation by all members of the group.

The model developed by the environmental conservation stakeholders used spatial datasets from the federal, state and county governments. The output generated by this stakeholder group is a snapshot in time of environmental value. As more information becomes available for the



Model Inputs (continued)

7. Conservation Priorities⁴³

- Lands for Specialty Preserves – Endangered Species Recovery Program
- San Joaquin Valley Kit Fox Recovery Areas – Core, Satellite, and Linkage
- The Nature Conservancy Portfolio Areas
- Audubon Important Bird Areas – Global and State Significance
- Southern Sierra Partnership Priorities – Core Conservation Areas, Primary buffer and connector areas, and Secondary buffer and connector areas
 - Environmental Stakeholder Satellite Areas of Concern: Eastern and Western natural vegetation foothill areas
 - California Rangeland Conservation Coalition Priorities: Critical and Important Areas

8. Federally Designated Critical Habitat - United States Fish and Wildlife Service

- Critical Habitat for Threatened and Endangered Species

9. Designated Lands

- California Conservation Easements Database, 2015 (GreenInfo)
- California Department of Fish and Wildlife – Owned and Operated Lands
- California Protected Areas Database, 2015 (GreenInfo)
- PAD-US (CBI Edition, Version 2.1), California

See **Appendix B** (see www.sjvp.databasin.org) for a complete listing, description, and links to the source data used in the environmental conservation model.

region, this particular model can be updated and refined. And while the 1km² grid cell reporting unit provides adequate detail for landscape level planning and for the purpose of the exercise, it is inappropriate for parcel-level siting applications – more detailed surveys and analyses will still be required. The logic model developed is transparent and flexible and reflects the interest of the group in a repeatable fashion.

Model Design

The approach chosen by this group relied on a logic model software called EEMS (Environmental Evaluation Modeling System) created by CBI. This method allowed for the incorporation of many different factors and logical arrangements of the data by the group to test ideas, was highly transparent, and could be updated as new data become available.

The diagram for the EEMS model developed by the environmental conservation group (Figure 5) illustrates how the various data inputs came together to generate the final map. All of the boxes in the diagram correspond to a map for that component. The model runs from the bottom up with the apex of the diagram (Conservation Value in this case) being the final model goal. As the key shows, the different raw and derived data inputs form the bottom of the diagram and, as the model runs upward, generate a number of intermediate products (shown as blue boxes). The diamond symbols denote the process of normalizing (or arranging all values along a continuum between a scale of -1 to +1) before logic operators (blue dots) instruct the program what to do logically to the data downstream of the symbol. For this model, the three different operators used to combine inputs included: Maximum, Average, and Weighted Sum. These types of logical functions allow for greater nuance than simply adding input components together or using a binary approach for identifying value.⁴⁴

Environmental Conservation Mapping Results

The environmental conservation model output classified all cells along a continuum from lowest conservation value (-1) (and therefore least-conflict) to most valuable (+1). The final least-conflict map shows concentrations of both high and low conservation value throughout the study area (Figure 6). Table 2 presents the model results as 6 discrete classes for easier summarization.

Logic models, like the one produced for this stakeholder group, provide insight into how spatially explicit areas are valued. The output produced is continuous, running from a lowest value (indicated by -1.00) to highest value (indicated by +1.00). When all cells on the map were labeled with a number along the continuum, the group needed to decide where along the continuum of values it would define “least conflict.” To accomplish this step, the group considered only the negative values in the spectrum. After careful review of natural breaks of the output values, the environmental conservation group chose a cutoff for determining least conflict for this exercise to be all values equal to or

TABLE 2. Total acres for each conservation value classification within the environmental conservation model boundary and within the solar stakeholder focal area.

| Conservation Value | Acres - Within the Conservation Extent | Acres - Within Solar Stakeholder Opportunity Area |
|---------------------------------|--|---|
| Very High (1.00 to 0.75) | 6,060,615 | 3,257,623 |
| High (0.75 to 0.50) | 2,103,024 | 1,926,486 |
| Moderately High (0.50 to 0.00) | 1,409,662 | 1,361,649 |
| Moderately Low (0.00 to -0.15) | 398,797 | 389,828 |
| Least Conflict (-0.15 to -1.00) | 2,600,914 | 2,599,681 |
| Total | 12,573,012 | 9,535,267 |

below -0.15, which identified over 2.6 million acres (32%) of the 9.5 million acres within the solar stakeholder focal extent (Figure 7). The majority of the areas highlighted as least-conflict were located on the Valley floor.

The least-conflict area and the output from the logic model are intended for high-level planning purposes and do not represent parcel-level evaluations. In addition, the output from this model is a snapshot in time from the standpoint of environmental conservation value within the greater San Joaquin Valley, which is likely to change as environmental conditions change in the future. The regions identified as least conflict are likely to have lower resource quality and lower environmental conservation conflicts. However, they may not be devoid of all value. Development siting surveys may encounter species and natural communities even on least-conflict lands.

Environmental Conservation Stakeholder Participants

- Ileene Anderson – Center for Biological Diversity
- Erica Brand – The Nature Conservancy
- Jennifer Buck-Diaz – California Native Plant Society
- Scott Butterfield – The Nature Conservancy
- Dick Cameron – The Nature Conservancy
- Mary Creasman – The Trust for Public Land
- Stephanie Dashiell – Defenders of Wildlife/The Nature Conservancy
- Kim Delfino – Defenders of Wildlife
- Sarah Friedman – Sierra Club
- Garry George – Audubon California
- Dan Gluesenkamp – California Native Plant Society
- Kate Kelly – Kelly Group
- Katie Krieger – Audubon California
- Liling Lee – Audubon California
- Adam Livingston – Sequoia Riverlands Trust
- Gordon Nipp – Sierra Club
- Helen O’Shea – Natural Resources Defense Council
- Shelby Semmes – The Trust for Public Land
- Greg Suba – California Native Plant Society

Sam Young – Swaim Biological
Carl Zichella – Natural Resources Defense Council

Agency Advisors

Scott Flint - California Energy Commission
Melanie Gogol-Prokurat – California Department of Fish and Wildlife
Pat Lineback – US Fish and Wildlife Service
Tom Lupo – California Department of Fish and Wildlife
Nathaniel Roth - California Geological Survey/California Department of Conservation

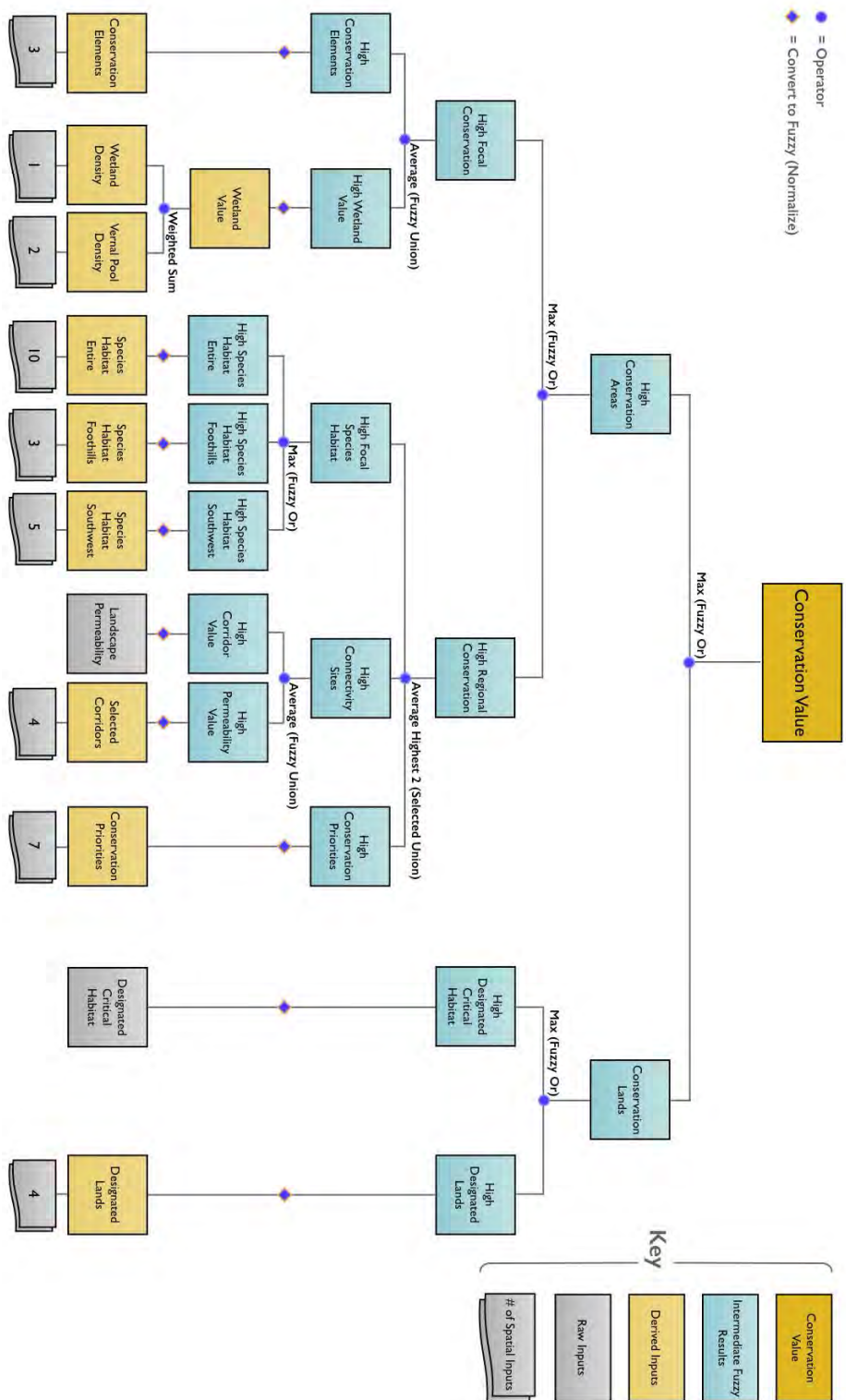

FIGURE 5. Least conflict output for the environmental conservation stakeholder logic model. Classifications presented for the entire conservation study area with the boundary for this planning extent shown in black. The solar stakeholder boundary is the red dashed line. The dark purple areas are classified as least conflict.

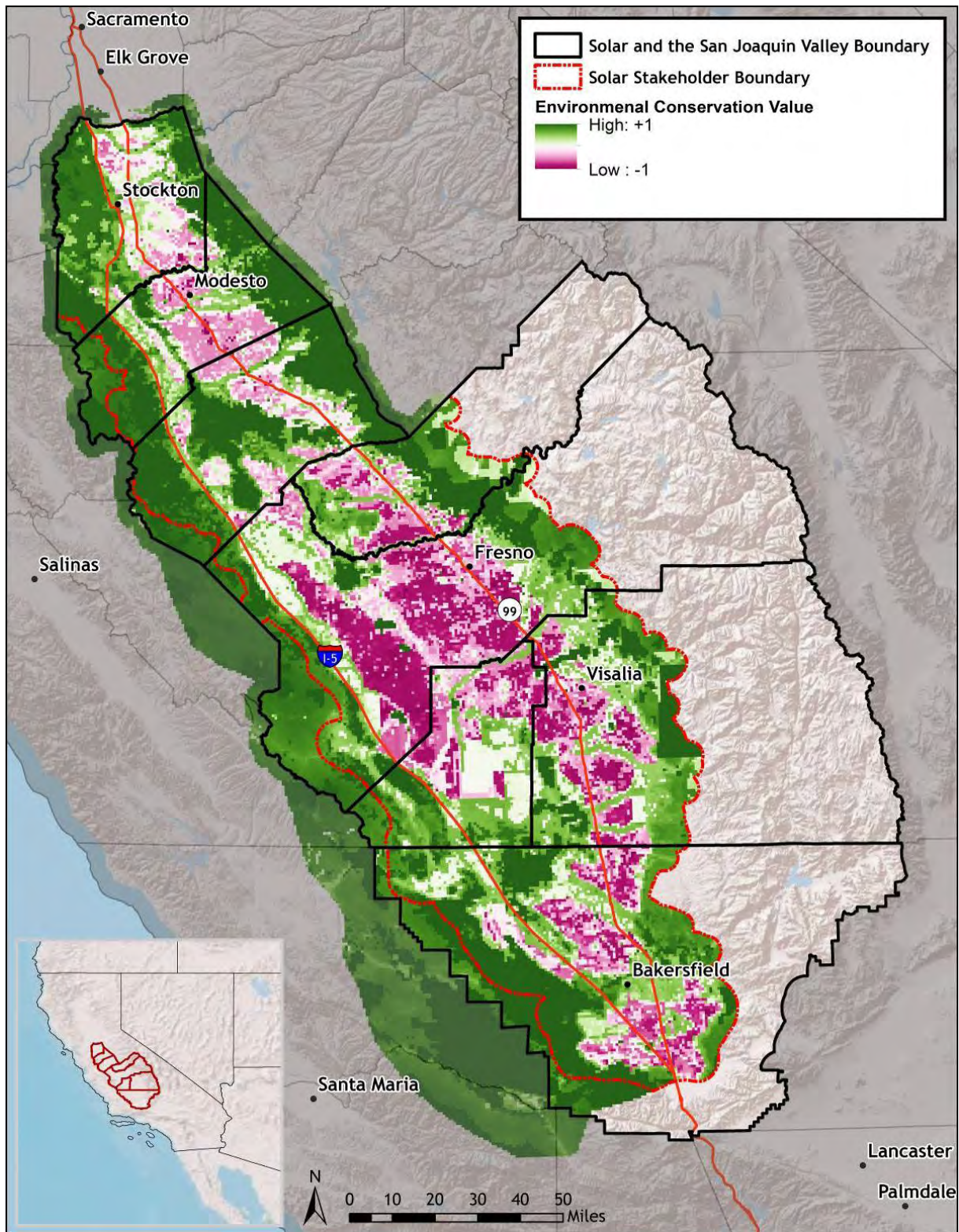

FIGURE 6. Final output for the environmental conservation stakeholder logic model. Classifications are presented for the entire conservation study area, with the boundary for this planning process shown in black. The solar stakeholder boundary is the red dashed line. All shades of green are higher-value areas as determined by the logic model; all shades of dark pink shown are lower-value areas.

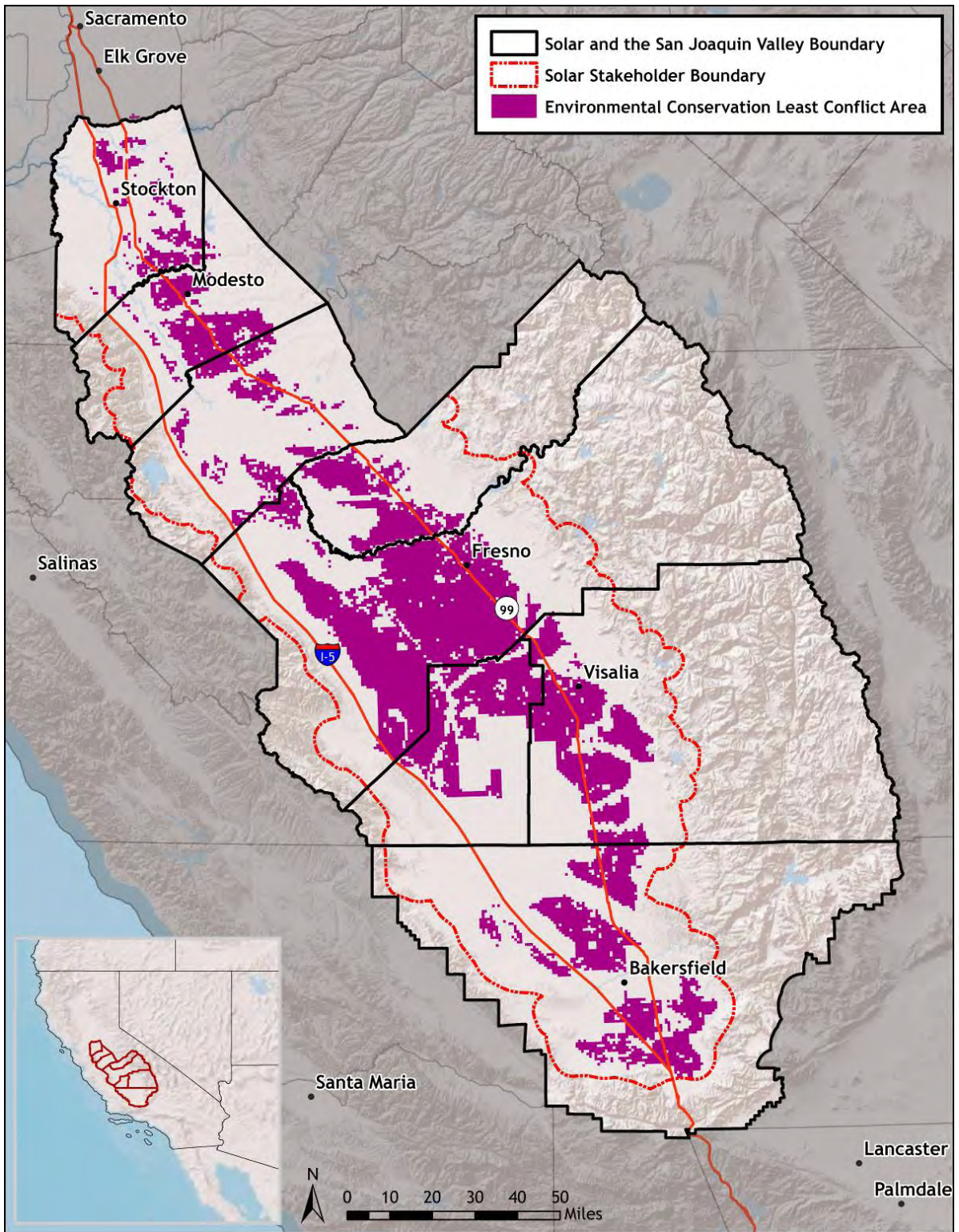

FIGURE 7. Least conflict output for the environmental conservation stakeholder logic model. Classifications presented for the entire conservation study area with the boundary for this planning extent shown in black. The solar stakeholder boundary is the red dashed line. The dark purple areas are classified as least conflict.



COMPOSITE LEAST-CONFLICT AREA IDENTIFICATION

Mapping Process

The main objective of this planning process was to identify least-conflict areas in the Valley for solar PV development. The solar industry, agricultural farmland conservation, and environmental conservation stakeholder groups generated spatially explicit data to answer this single question. The solar group developed a focal opportunities map, while the agricultural farmland and the environmental conservation stakeholder groups generated least-conflict area maps from their group perspectives. Combining the two least-conflict results within the solar stakeholder boundary (Figure 8) allowed a simple way to see where both agreed, resulting in a **composite least-conflict areas map**. This method allowed for a common language of least-conflict identification, using different methods and outputs from multiple stakeholder groups efficiently.

The full definitions for the composite least-conflict areas are:

Priority least-conflict area – Least-conflict areas identified by the environmental conservation stakeholder group and the priority least-conflict areas category identified by the agricultural farmland stakeholder group.

Least-conflict area – Least-conflict areas identified by the environmental conservation stakeholder group and the least-conflict areas category identified by the agricultural farmland stakeholder group.

Potential least-conflict area – Least-conflict areas identified by the environmental conservation stakeholder group and the potential important agricultural areas category identified by the agricultural farmland stakeholder group.

Composite Mapping Results

Composite least-conflict areas totaled over 470,000 acres (~5%) of the 9.5

million acres within the solar stakeholder boundary (Table 3). Least-conflict areas are represented in the mapped results (Figure 9 – Figure 12) from dark green (Priority Least-Conflict areas) to yellow (Potential Least-Conflict areas). The Priority Least-Conflict areas concentrated in the central portion of the Valley, found mostly within Fresno County and Westlands Water District. Least-Conflict areas occurred in scattered fashion throughout the other Valley counties. The Potential Least-Conflict Areas were concentrated in Fresno, Kings, and Madera counties, with some additional larger areas situated in Kern County north of Bakersfield.

TABLE 3. Total acres for each composite least-conflict classification within the solar stakeholder focal area

| Composite Least-Conflict Classification | Acres - Within Solar Stakeholder Focal Extent |
|---|---|
| Priority Least-Conflict Area | 202,330 |
| Least-Conflict Area | 151,901 |
| Potential Least-Conflict Area | 117,263 |
| Total | 471,495 |

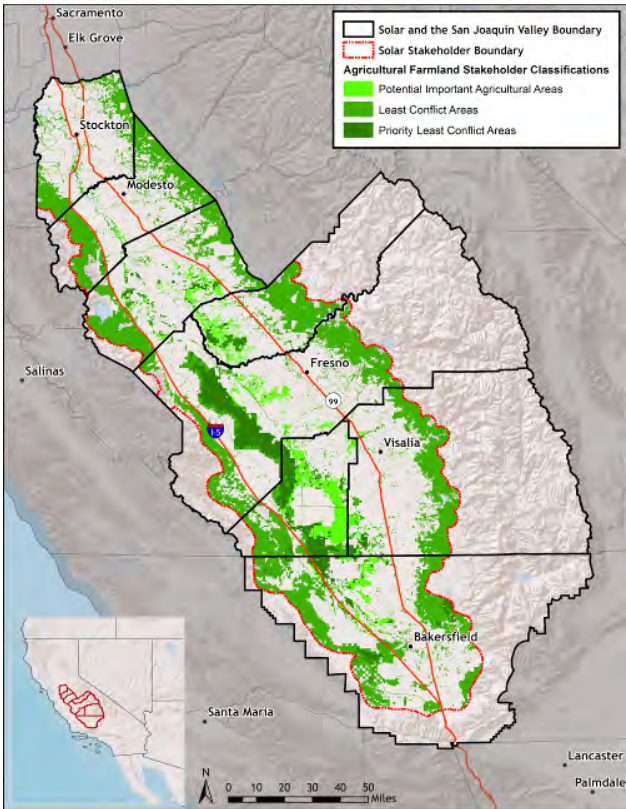
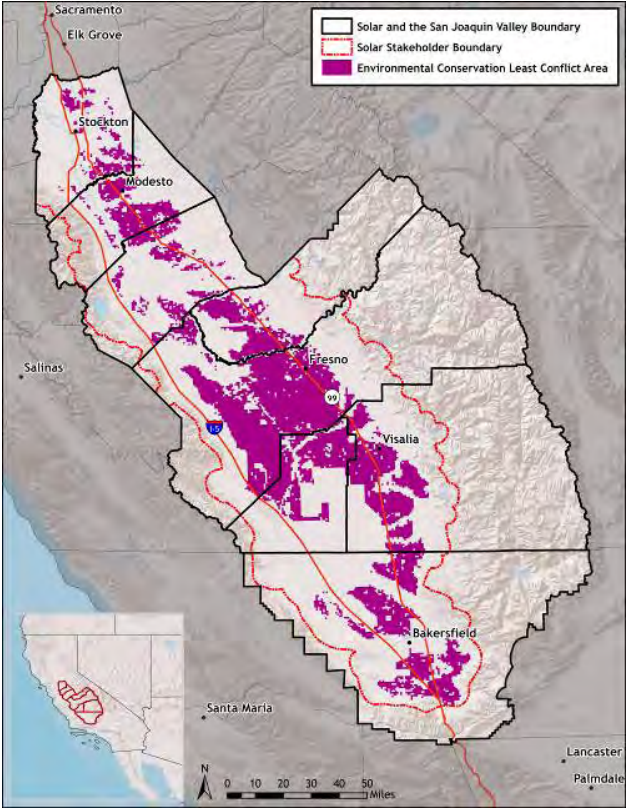

FIGURE 8. Development of the composite least-conflict areas. The figure on the left shows the least-conflict area identified by the environmental conservation stakeholders. The figure on the right shows the least-conflict classifications identified by the agricultural farmland conservation stakeholders.

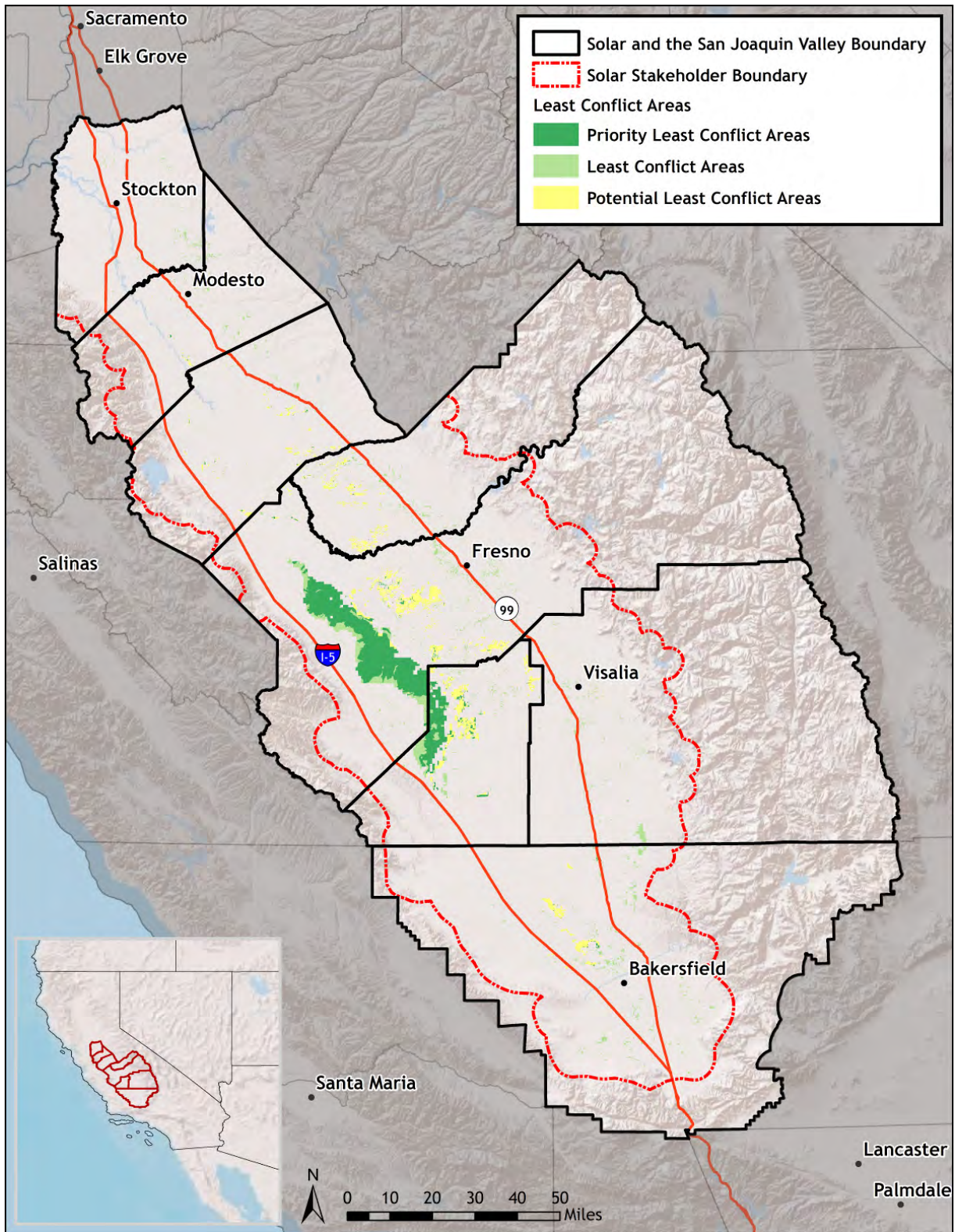

FIGURE 9. Least conflict composite output. Classifications presented for the entire conservation study area with the boundary for this planning extent shown in black.

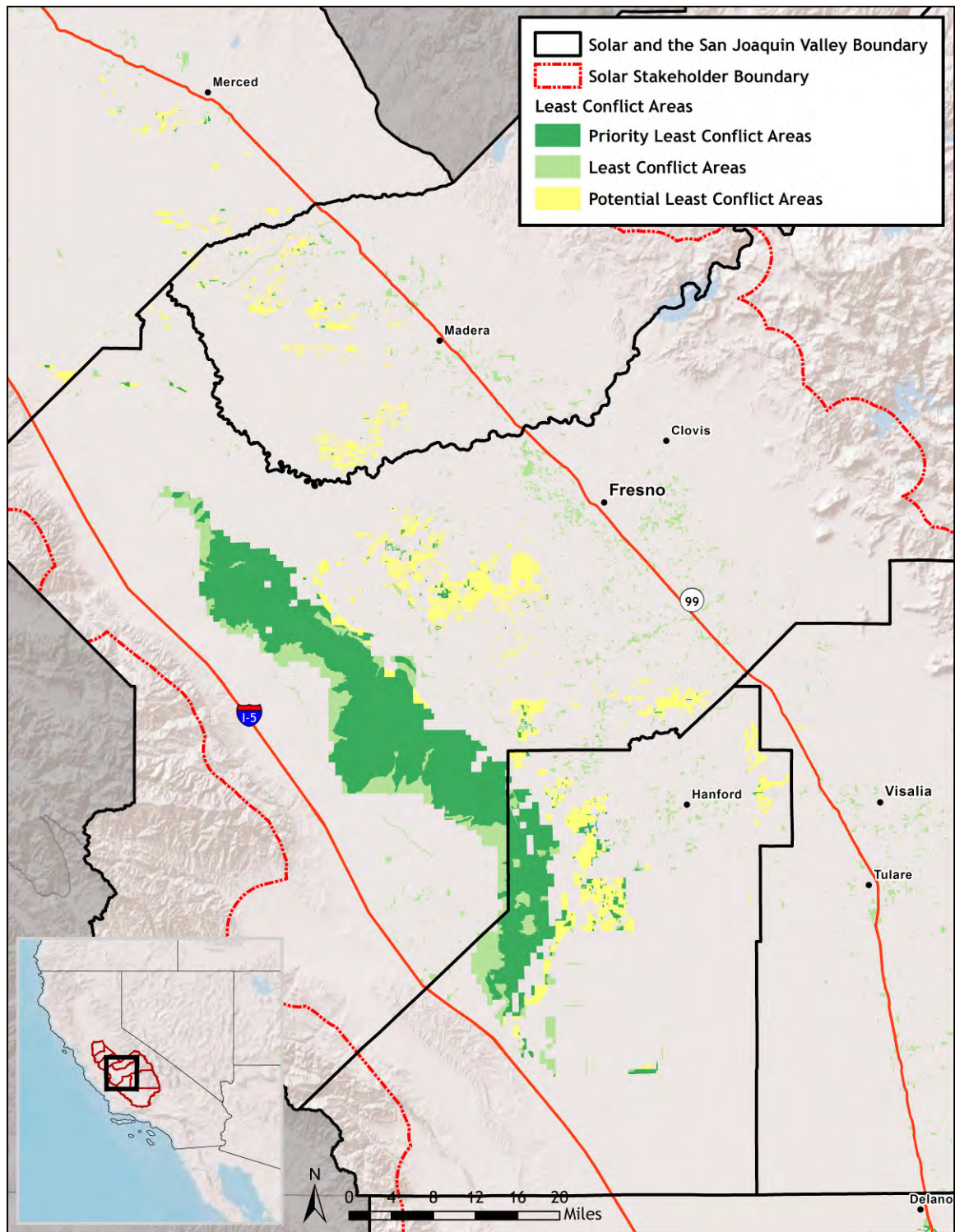

FIGURE 10. Least-conflict composite - middle section of the San Joaquin Valley. Counties shown include Tulare, Kings, Fresno, Madera, and Merced. Classifications presented for the entire conservation study area with the boundary for this planning extent shown in black. The solar stakeholder boundary is the red dashed line.

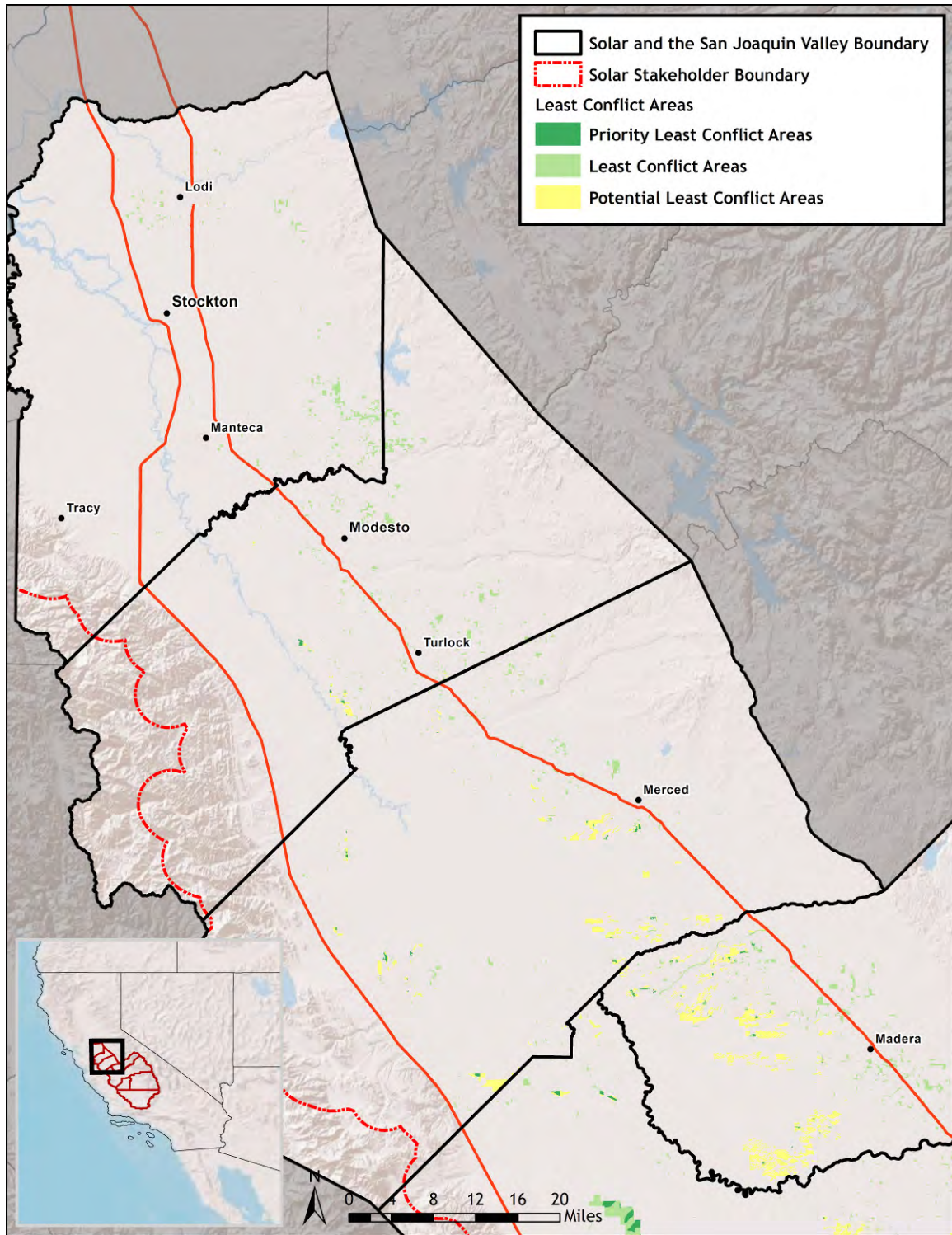

FIGURE 11. Least-conflict composite output – northern section of the San Joaquin Valley. Counties shown include Stanislaus, San Joaquin, Madera, and Merced. Classifications presented for the entire conservation study area with the boundary for this planning extent shown in black. The solar stakeholder boundary is the red dashed line.

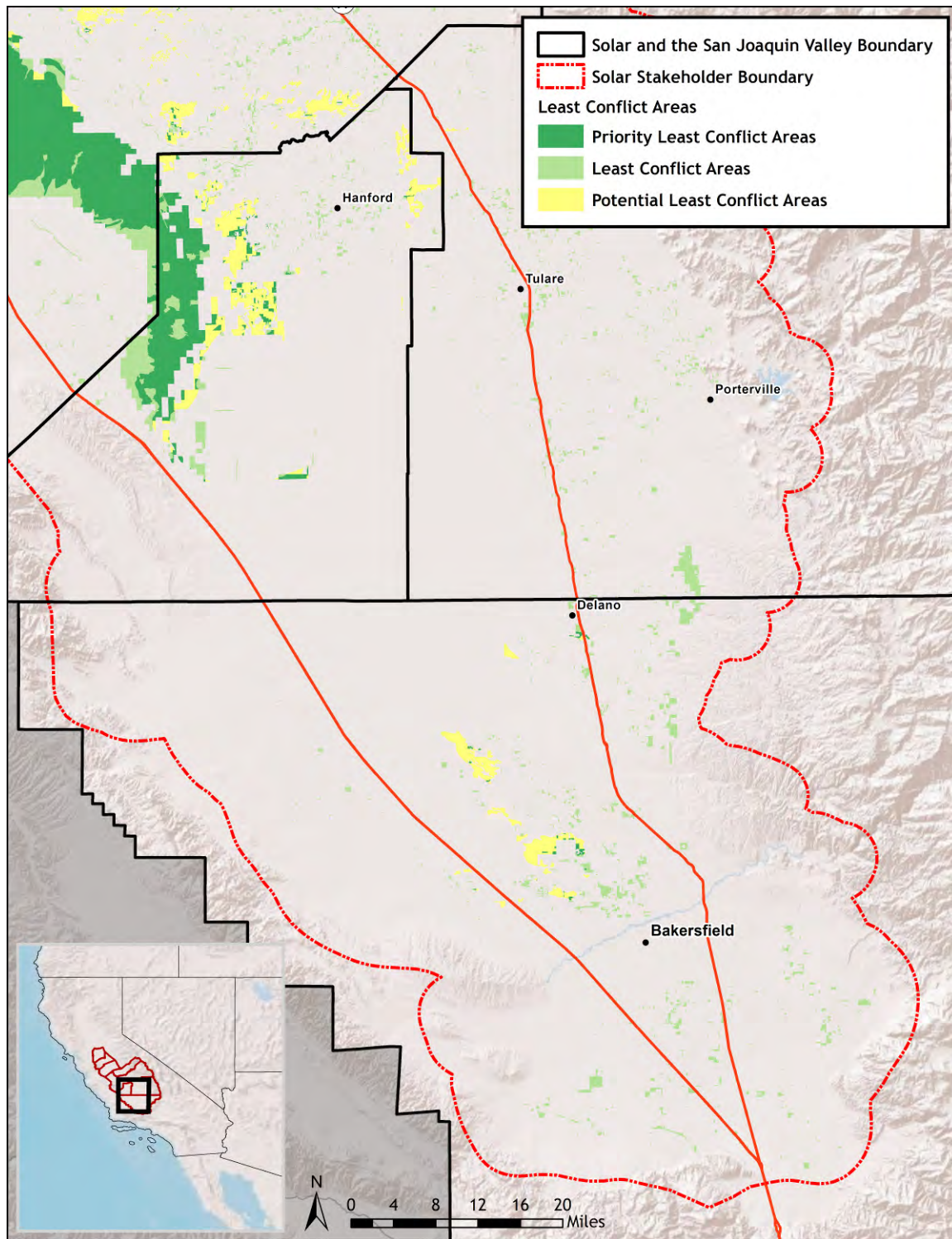

FIGURE 12. Least-conflict composite - southern section of the San Joaquin Valley. Counties shown include Tulare, Kings, Fresno, and Kern. Classifications presented for the entire conservation study area with the boundary for this planning extent shown in black. The solar stakeholder boundary is the red dashed line.



AGRICULTURAL RANGELAND STAKEHOLDER MAPPING

The San Joaquin Valley's remaining natural areas are often found within the rangelands of the foothills in the Sierra Nevada and Coastal Ranges. These rangelands, as all rangelands within California, provide valuable habitat for endangered and threatened species, enable connectivity for species and ecological processes, and represent the foundation for many ecosystem services in the state.⁴⁵ The majority of rangelands in the Valley remain in private ownership, some of which have been protected through individual voluntary action.

As more information on rangeland management emerges, the vital link these areas play in California for continued environmental quality and protection has become a repeated theme. An expanding human population and agricultural intensification in the Valley pose a continuing threat to these areas.⁴⁶ Policy makers need to consider and weigh expected losses of rangelands and grasslands against the impacts on the ecosystem services they provide.

Mapping Process

The agricultural rangeland group, which consisted of 11 members from non-profits, ranching organizations, and consulting firms, directed CBI staff to develop an information overlay for the study area showing potential rangeland. This mapping was undertaken by using existing data to extract areas of rangeland importance and potential importance.

Results were generated for all of California, with areas shown only for the eight Valley counties. The counties shown with potential rangeland included Kern, Kings, Tulare, Fresno, Madera, Merced, Stanislaus, and San Joaquin. The data used in this mapping process came from the California Department of Forestry and Fire Protection's 2015 vegetation dataset. All areas shown are considered to be of equally high value for agricultural rangeland uses by this stakeholder group.



Source Data

California Department of Forestry and Fire Protection 2015 Vegetation Dataset⁴⁷

26 Identified California Wildlife Habitat Relationship classes associated with rangeland

- 1) Alpine-Dwarf Shrub ADS
- 2) Annual Grassland AGS
- 3) Alkali Desert Scrub ASC
- 4) Bitterbrush BBR
- 5) Blue Oak-Foothill Pine BOP
- 6) Blue Oak Woodland BOW
- 7) Coast Oak Woodland COW
- 8) Chamise-Redshank Chaparral CRC
- 9) Coastal Scrub CSC
- 10) Desert Riparian DRI
- 11) Desert Scrub DSC
- 12) Desert Succulent Shrub DSS
- 13) Desert Wash DSW
- 14) Joshua Tree JST
- 15) Juniper JUN
- 16) Low Sage LSG
- 17) Mixed Chaparral MCH
- 18) Montane Chaparral MCP
- 19) Montane Riparian MRI
- 20) Perennial Grassland PGS
- 21) Pinyon-Juniper PJN
- 22) Palm Oasis POS
- 23) Sagebrush SGB
- 24) Valley Oak Woodland VOW
- 25) Valley-Foothill Riparian VRI
- 26) Wet Meadow WTM

The output generated for the agricultural rangeland group was stakeholder driven and controlled. The final output was similar to the information originally provided by the group, but it represents the most recent version of vegetation classification, allowing for higher vegetation distinction throughout California and within the Valley. Initial direction and group involvement was directed during an in-person meeting, with all review and editing occurring through online conferences, by email, or through phone communications. This mapping process did not require extensive iteration and editing, which allowed for development of the data quickly to align it with the other mapping processes that had already been underway.

Inputs for the mapping were based upon the most recent vegetation data that show potential rangeland within the California. This mapping does not represent ground-tested data. The mapping of potential rangeland shows areas that are used or may be useful for rangeland uses. The output created by the agricultural rangeland stakeholder group can be used for planning purposes, with the caveat that the data are snapshots in time.

Data Development

Using an approach created by the California Rangeland Research and Information Center (UC Cooperative/UC Davis), the project team queried the California Department of Forestry and Fire Protection's 2015 vegetation dataset for the 26 different wildlife habitat relationship codes that identify rangeland within California. The areas identified were then selected and extracted from the larger vegetation dataset and attributed based upon their wildlife habitat relationship code to allow for easier identification.

The definition for rangeland that guided the selection of the 26 specific wildlife habitat relationship classes comes from the Society for Rangeland Management:

"Rangelands are lands on which the indigenous vegetation is predominantly grasses, grass-like plants, forbs or shrubs and is managed as a natural ecosystem. They include grasslands, savannas, shrublands, deserts, tundras, marshes and meadows."⁴⁸

This definition can be expanded upon when using the California Code of Regulations' definition of rangeland, California Code of Regulations, title 14, section 1561.1 and Public Resources Code section 4789.2. Title 14, section 1561.1 (under the Chaparral Management Chapter) states:

"Rangeland means the land on which the existing vegetation, whether growing naturally or through management, is suitable for grazing and browsing. Rangeland includes any natural grasslands, savannas, shrublands, deserts, woodlands, and wetlands which support a vegetative cover of native grasses, grass-like plants, forbs, shrubs, or naturalized species. Rangeland is land that is dominated by vegetation other than trees. Many woodlands (including Eastside ponderosa pine, pinyon, juniper, chaparral, and oak woodlands) are included in

rangelands because their response to range management principles and activities are similar to those of other shrubby ecosystems.”

Both definitions capture the value of rangeland and the complex vegetation types that make up rangeland in California. The agricultural rangeland stakeholders intended to capture this complexity in the data development.

Agricultural Rangeland Mapping Results

The agricultural rangeland mapping exercise found areas of potential rangeland throughout all eight Valley counties (Figure 13). The areas shown are primarily in the foothills and mountainous areas of the counties. Looking just at the areas within the solar stakeholder boundary, the majority of areas identified as potential rangeland are in the natural and rural landscapes of the Valley foothills with some large areas found on the Valley floor.

Total acreages of the identified potential rangeland within the Valley is 5,799,453 acres. Areas identified as potential rangeland within the solar stakeholder boundary were over 2.6 million acres (27%) of the 9.5 million acres within the solar stakeholder boundary. Areas were highly correlated with high value environmental conservation lands.

Agricultural Rangeland Stakeholder Participants

Theresa Bechetti – University of California Cooperative Extension

Dick Cameron – The Nature Conservancy

Kim Delfino – Defenders of Wildlife

Michael Delbar – The California Rangeland Trust

John Gamper – California Farm Bureau Federation

John Garamendi Jr. – Professional Evaluation Group Inc.

Billy Gatlin – California Cattlemen’s Association

Justin Oldfield – California Cattlemen’s Association

Jean Okuye – East Merced Resource Conservation District

Karen Sweet – California Rangeland Conservation Coalition

Anthony Toso – ELT Agricultural Appraisers and Consultants

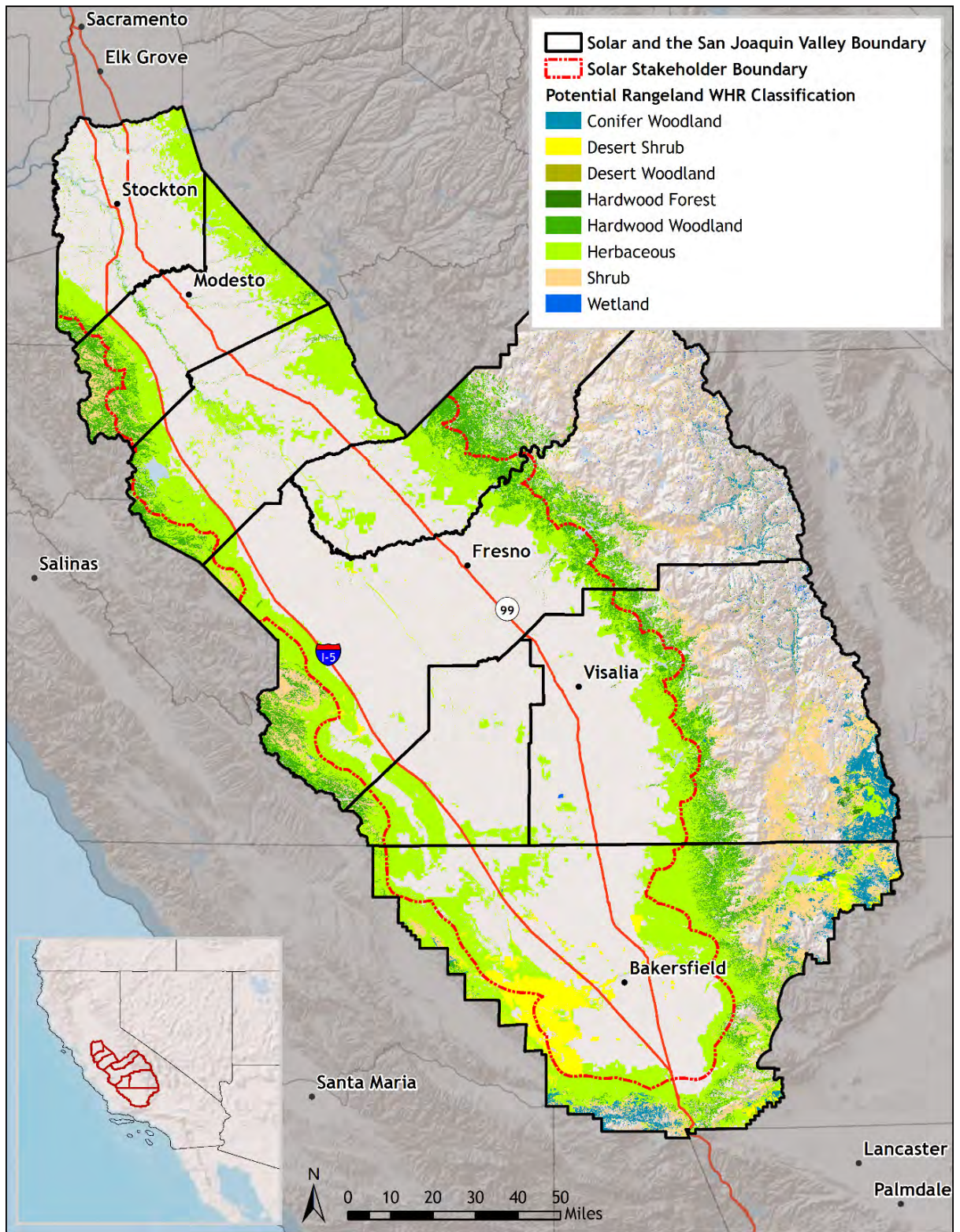

FIGURE 13. Final agricultural rangeland output. Wildlife habitat relationship classes (WHR13) are shown for the entire eight San Joaquin Valley counties with the boundary for the study shown in black. Red dashed boundary depicts solar stakeholder foal area. All classes on the map are considered of equally high value for agricultural rangeland uses.



CONTEXT WITHIN THE SAN JOAQUIN VALLEY

Tribal Considerations

Introduction

Some of the land in the San Joaquin Valley directly affects tribal interests in the region. As a result, solar PV planning and development will need to address federal and state laws pertaining to tribal jurisdiction and consultation. In addition, tribal governments and leaders represent important decision-makers in this process. Project leaders therefore attempted to acknowledge and address tribal considerations through outreach. This section of the report discusses: (1) the Native American groups and tribes affiliated with the San Joaquin Valley solar planning area (Valley planning area); (2) tribal concerns about solar development in the Valley planning area; (3) consultation methods and outcomes among tribes, the Governor's Office of Planning and Research (OPR) and the California Energy Commission (CEC); and (4) tribal recommendations for solar development in the Valley planning area.

Consultation with California Native American Tribal Governments is the responsibility of local, state, and federal agencies and is detailed in several sections of federal and state law and policy. Most such authorities on tribal consultation apply to general plans and specific project proposals, not long-range conceptual planning and advisory programs such as the San Joaquin Valley study.⁴⁹ For the state agencies conducting this planning exercise, however, Governor's Executive Order B-10-11 (signed by Governor Brown in September 2011) encourages state agency collaboration with California Tribal Governments. The executive order directs state agencies to afford California Native American Tribes, including federally recognized and non-recognized, the opportunity to "provide meaningful input into the development of policy on matters that affect tribal communities." The CEC

Contributed by Thomas Gates
Supervisor, Cultural Resources
California Energy Commission

Gabriel Roark
Energy Analyst, Cultural Resources,
California Energy Commission

and OPR are working in an advisory role with stakeholders in this planning effort. The California Natural Resources Agency policy also exhorts state agencies under its jurisdiction to give California Native American Tribes and tribal communities the opportunity to provide meaningful input into state agency plans and policies that may affect tribal communities. The CEC also uses a tribal consultation policy that operationalizes the California Natural Resources Agency’s consultation policy for CEC programs and projects.

| Cultural Affiliation | Name of Tribe |
|--|--|
| Me-Wuk/Miwok/Miwuk | Buena Vista Rancheria of Me-Wuk Indians |
| | Calaveras Band of Mi-Wuk Indians |
| | Calaveras County Mountain Miwok Indian Council |
| | California Valley Miwok Tribe |
| | Chicken Ranch Rancheria of Me-Wuk |
| | Ione Band of Miwok Indians |
| | Jackson Rancheria Band of Me-Wuk Indians |
| | Shingle Springs Band of Miwok Indians |
| | Southern Sierra Miwok Nation |
| | Tuolumne Band of Me-Wuk |
| | Wilton Rancheria |
| Yokuts—Northern and Southern Valley/Foothill | Choinumni Tribe of Yokuts |
| | Dumna Wo-Wah Tribal Government |
| | Kings River Choinumni Farm Tribe |
| | North Valley Yokuts Tribe |
| | Picayune Rancheria of Chukchansi Indians |
| | Santa Rosa Rancheria |
| | Table Mountain Rancheria |
| | Traditional Choinumni Tribe |
| | Tule River Indian Tribe |
| Mono (Monache) | Big Sandy Rancheria of Western Mono Indians |
| | Cold Springs Rancheria of Mono Indians |
| | North Fork Mono Tribe |
| | North Fork Rancheria |
| Costanoan | Amah Mutsen Tribal Band |
| | Amah Mutsun Tribal Band of Mission San Juan Bautista |
| Kitanemuk/Kawaiisu | Kern Valley Indian Council |
| | Tejon Indian Tribe (Southern Valley Yokuts) |

TABLE 4. Native American groups traditionally and culturally affiliated with the study area.

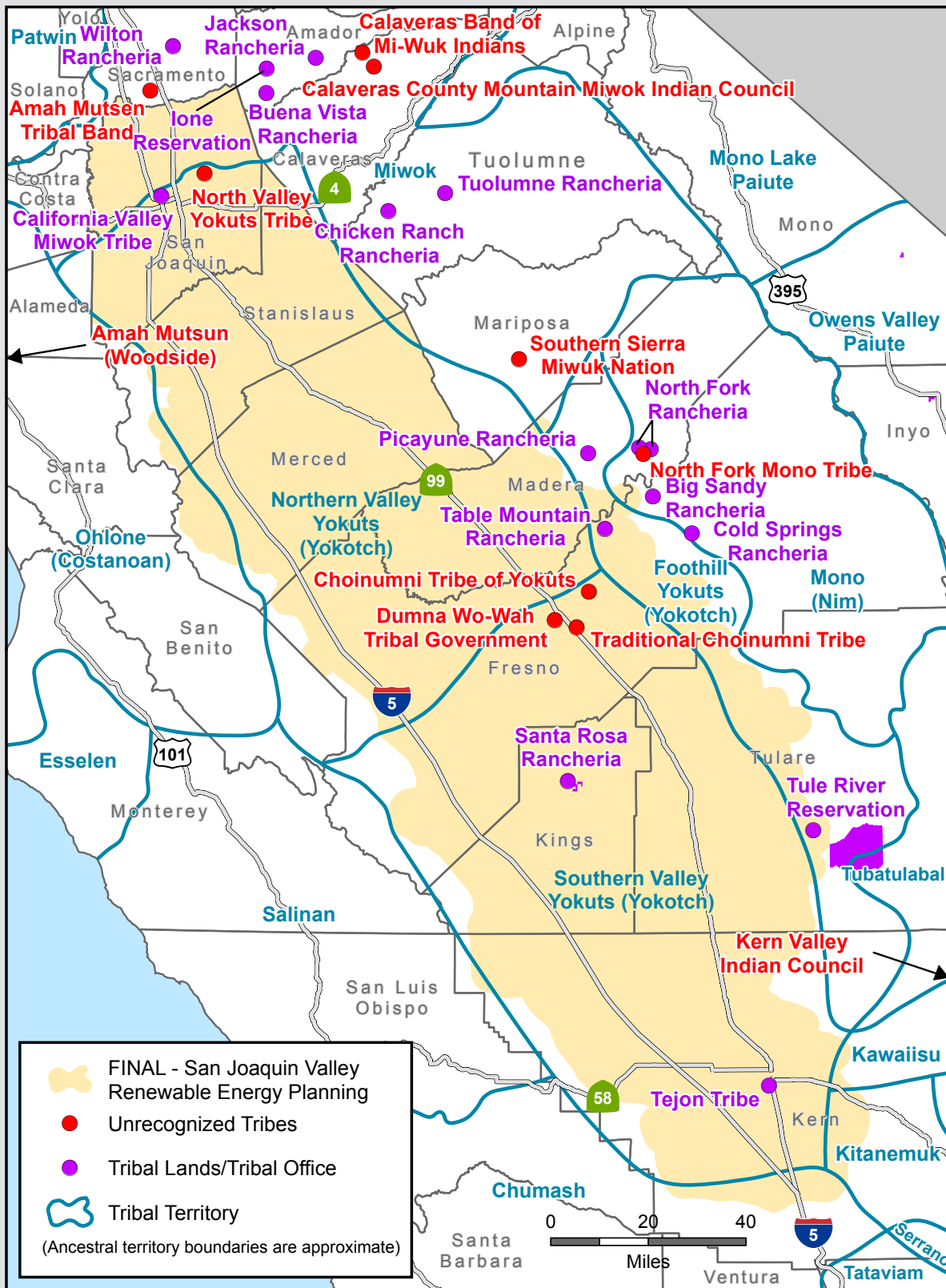

FIGURE 14. San Joaquin Valley Planning Area tribal governments, lands, and territories.

Native American Cultural Affiliations and Tribal Governments

The Valley planning area has supported—and continues to support—a rich and diverse Native American cultural legacy (Table 4, Figure 14). The southern area has yielded some of the most ancient sites known in California, some dating to about 11,000 years ago.⁵⁰

Cultural Description

The Valley planning area is located on the floor of the San Joaquin Valley. The Valley is culturally affiliated primarily with the Yokuts, comprising three broad divisions: Northern Valley, Southern Valley, and Foothill.⁵¹ The Northern Valley Yokuts are affiliated with the northern portion of the San Joaquin Valley, including the southern half of San Joaquin County, most of Stanislaus and Merced counties, portions of Santa Clara and San Benito counties, the western half of Madera County, and the northwestern portion of Fresno County (Figure 18).⁵² The Southern Valley Yokuts are affiliated with the southwestern portions of Fresno County, most of Kings County, and the western portions of Tulare and Kern counties.⁵³ The Foothill Yokuts are culturally affiliated with the eastern side of the valley from Madera County to Kern County.⁵⁴ The three Yokuts subgroups (Northern Valley, Southern Valley, and Foothill) are further distinguished by 40–50 dialect groups, each clustered in areas consisting of one to several villages.⁵⁵

The Southern Valley Yokuts traditionally occupied the areas around Kern, Buena Vista, and Tulare lakes, as well as some of the rivers that issue from the Southern Sierra Nevada mountain range, notably the Kern, Tule, Kaweah, and Kings rivers. This environment provided diverse plants and animals that were used as food and fiber sources, implements, and housing. The tule of the lakes and sloughs had various uses as food and shelter and was the prime material used for fashioning watercraft.

The Northern Valley Yokuts traditionally occupied an area that takes in the lower reaches of the rivers flowing out of the Sierra Nevada foothills and into the San Joaquin River from the Fresno River in the south to the Calaveras River in the north. The area includes the San Joaquin River for most of its reach from where it emerges from the Sierra Foothills to the Sacramento-San Joaquin River Delta. The western side of Northern Valley Yokuts territory follows the Diablo Range's eastern foothills. Acorns from various species of oak increased in use from the south to the north. Subsistence reliance on salmon and sturgeon increased to the north.

The Foothill Yokuts traditionally occupied the western slopes of the Sierra Nevada between the Fresno and Kern rivers. Historically, the foothill people comprised approximately 15 distinct tribes, each of which lived among one or two river drainages, with villages distributed along streams. The majority of Foothill Yokuts villages were situated between 2,000 and 4,000 feet above mean sea level, providing ready access to the valley-floor grasslands, lower foothill oak groves, and upper foothill pine forests. This well-positioned location fostered an economy of hunting and gathering terrestrial resources, supplemented by fishing.

The tribes affiliated with the San Joaquin Valley, surrounding foothills, mountains and delta participate in intricate socio-political units and profound religious traditions that guide individuals through the lifecycle in ways that bind indigenous people with their environments.

Relationships with Non-Indian Societies

The various Yokuts tribes first felt the effects of European and American contact at different points in time. But they had a unified experience of harm in their interactions with foreigners. The Southern Valley Yokuts were the first to encounter the Spaniards during the latter's late eighteenth-century explorations of the southern San Joaquin Valley. Initial Yokuts-Spanish interactions were infrequent; the Valley was far from the coastal mission strip and separated from it by the rugged South Coast Ranges. Spanish forays into the Northern Valley Yokuts' lands commenced in the early 1800s with reconnaissance of the Sacramento-San Joaquin River Delta. Periods of sparse, early encounters resulted in the Spanish removing some Tachi Yokuts (Southern Valley Yokuts division) and Northern Valley Yokuts to Missions Soledad, San Antonio, San Jose, San Luis Obispo, and San Juan Bautista.⁵⁶

After the United States annexed California, the Yokuts endured forced removal to reservations like the Fresno, Tejon, and Tule River Indian reservations or lived in hamlets or isolated homes in their traditional territories, particularly in the hills and mountains. The Foothill Yokuts were able to reside on or near some of the historic villages until the middle twentieth century, when the federal government's reservoir-building program inundated several river valleys that were once vital parts of Yokuts communities. The breakup of traditional communities weakened knowledge of native social organization and life-ways. Despite this history, many California Indian tribes have sought and received federal recognition. They and non-federally recognized tribes and organizations work to preserve California Native American culture and material heritage.

Native Americans on the Valley Periphery

Numerous non-Yokuts Indians inhabited the edges or smaller portions of the San Joaquin Valley: Miwok, Mono (Monache, Nim), Tubatulabal, Kawaiisu, Kitanemuk, Chumash, Salinan, and Costanoan (Ohlone).⁵⁷ All of these groups had hunter-gatherer economies broadly similar to those of the Yokuts, except for coastal subsistence. In the portions of their territories that intersect the Valley planning area, aboriginal land use probably most closely resembled that of the Northern Valley Yokuts of the delta area and the Foothill Yokuts. Beyond similarities in food acquisition, the tribal groups surrounding the Yokuts intermarried, socialized, traded, and sometimes engaged in armed conflict with the Yokuts. Particularly intense and frequent interactions occurred along the South Coast Ranges-Valley interface (Northern Valley and Tachi Yokuts-Eastern Costanoan tribes), in the foothill homelands of the Monache (or Mono) and Foothill Yokuts, and—especially after the upheaval caused by the Gold Rush—the Miwok-Northern Foothill Yokuts divide. Consequently, diverse contemporary Native American tribes and organizations maintain a cultural interest in the San Joaquin Valley and

adjacent uplands. The archaeological record of peripheral portions of the plan area likely relates to more than one culture groups rather than to a single Native American culture.

Tribal Consultation and Concerns

The CEC and OPR identified 28 tribes that have cultural affiliation to some portion of the Valley planning area (see Table 1). Agency staff sent outreach letters to 36 members of tribal leadership and cultural resources staff on October 9, 2015. The letters outlined the planning intent and process, invited tribal involvement, and signaled that state agency staff would follow up with tribes. CEC and OPR staff followed up with tribes via email and telephone to ascertain the tribal level of interest in this San Joaquin Valley study.

Based upon initial tribal responses and interest in the study, the project team held a Webex presentation on November 6, 2015. The presentation provided participating tribes with the three least-conflict maps (Solar Stakeholder Boundary, Agricultural Rangeland Stakeholder, and Environmental Conservation Stakeholder) and the composite map reflecting geographic agreement among these four stakeholders' mapping. The project team also showed a map of military operational areas. A November 18, 2015 informational meeting was hosted by Santa Rosa Tachi Yokut Rancheria near Lemoore, California. Meeting participants included representatives and staff from the Yokuts (Picayune Rancheria of Chukchansi Indians, Santa Rosa Rancheria, Table Mountain Rancheria, and the Tule River Tribe), OPR, and CEC.

CEC and OPR staff also received written and verbal comments on tribal concerns from some of the consulted tribes. Tribes that provided written comments included the Buena Vista Rancheria of Me-Wuk Indians, California Valley Miwok Tribe, and Tejon Indian Tribe. The Amah Mutsen Tribal Band and Table Mountain Rancheria provided verbal comments.

In addition to the comments referenced in the paragraph above, Table Mountain Rancheria, Tule River Reservation, and Santa Rosa Rancheria compiled a map of Tribal Areas of Concern in the vicinity of the Least-Conflict Solar Areas identified by the other stakeholder groups. Prior to providing the result to OPR and the CEC, these tribes sought input from Picayune Rancheria of Chukchansi Indians as well.⁵⁸ Although Picayune Rancheria did not provide additional mapping information, the tribe confirmed that the data compiled by the other tribes were consistent with their knowledge of tribal concerns in the Valley. OPR and CEC staff held conference calls with Table Mountain Rancheria cultural resources staff on January 29 and February 3, 2016 to better understand the data, the methods entailed in collecting the data, and confidentiality issues surrounding the Tribal Areas of Concern Map.

The four tribes compiled their cultural resources information for a study area that comprised the three grades of least-conflict areas (as defined by the Solar Development, Environmental Conservation, and Agricultural

stakeholder groups) into a map that OPR and the CEC developed. The four tribes delineated the Tribal Areas of Concern by mapping known cultural resource locations from the California Historical Resources Information System, tribal preservation office files and monitoring reports, and published ethnographic documents. The Tribal Areas of Concern also include locations known to tribal elders as containing tribal cultural resources. The Tribal Areas of Concern encompass natural features (both existing and former) that are likely to contain or indicate the presence of tribal cultural resources. The four tribes then applied buffers surrounding known resources and resource indicators but did not further delineate or quantify site types in relation to the buffers, in order to protect the confidentiality of the data. In essence, the Tribal Areas of Concern comprise “areas of greatest conflict” from a tribal perspective.

The Tribal Areas of Concern are likely to include the following types of cultural resources: former village sites, other types of archaeological sites, unmarked burial grounds, and traditional resource-gathering locations. Other types of resources and concerns might be present as well.

The resource information underlying the Tribal Areas of Concern map are confidential, as they pertain to archaeological and tribal resource locations that are protected, under federal and state law, from public disclosure. The four tribes agreed that a fair use of the data for OPR and the CEC planning purposes would involve incorporating the Tribal Areas of Concern into the Valley planning area geographic information system, masking areas where the Tribal Areas of Concern overlap with the other stakeholder groups’ least-conflict areas, and producing a map that displays the results (Figure 15). *Note that the Tribal Areas of Concern are not displayed to protect the confidentiality of these data.*

The CEC and OPR appreciate the effort of tribes to provide input into this planning process. The following concerns represent information from tribal governments for the use of participants in solar development.

1. Tribes are concerned that renewable energy projects could disrupt flyways for migratory birds. Tribes have culturally prescribed stewardship obligations for the natural environment and use the plumage of some bird species in ceremonial objects to this day.
2. Tribes are concerned about the potential for bird impacts resulting from glare and collision with facility infrastructure.
3. Tribes are also concerned that solar projects may impact, minimize or otherwise compromise the riparian corridors throughout the San Joaquin Valley. These corridors represent some of the only remaining wildlife habitats and migratory pathways.
4. Tribes are concerned about the amount of water usage and potential groundwater quality issues related to renewable energy projects.
5. Despite the major alteration of much of the plan area from native

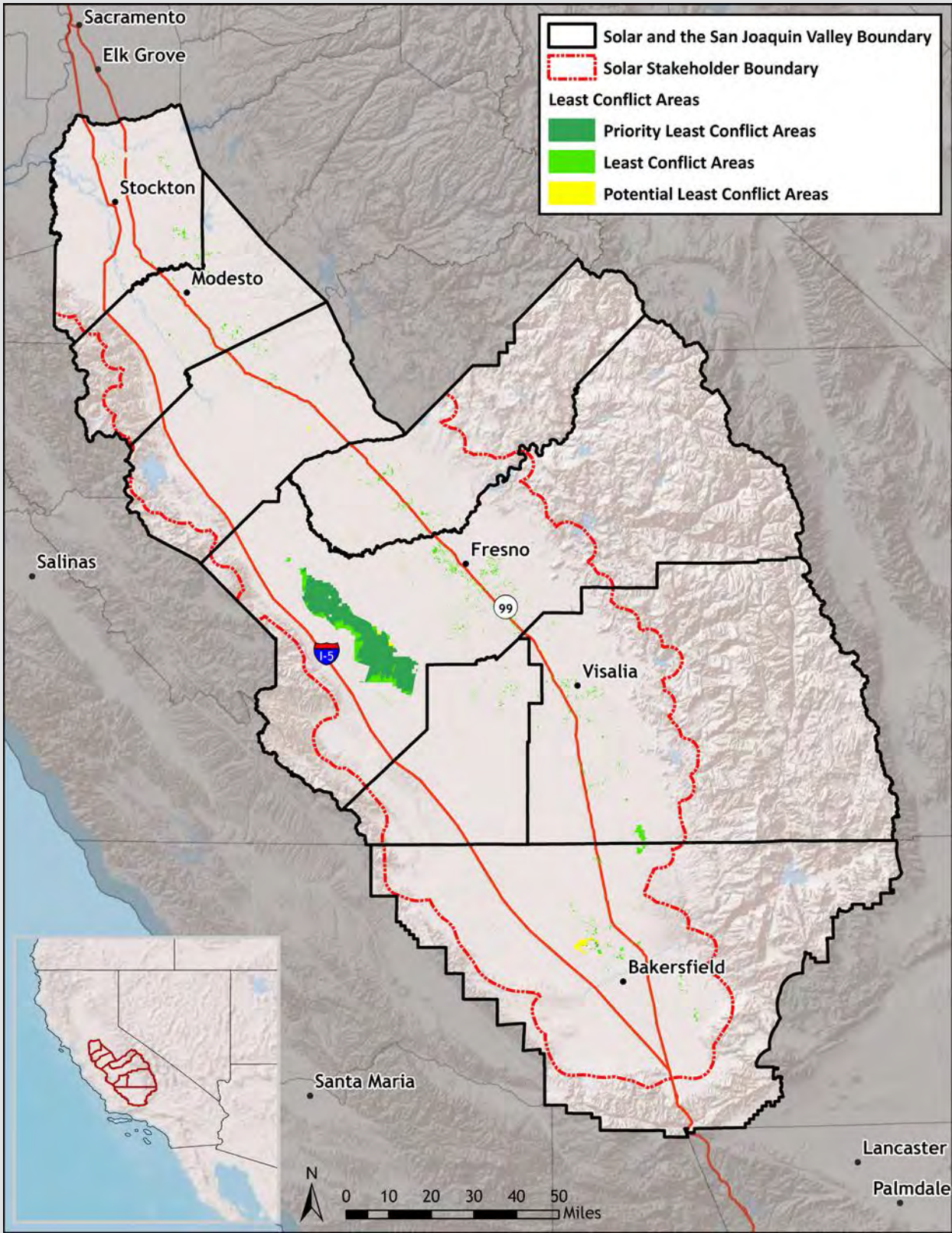

FIGURE 15. San Joaquin Valley least-conflict areas informed by tribal areas of concern.

conditions, there are numerous San Joaquin Valley areas in which significant cultural resources can still be found. These localities share characteristics with others in the plan area, showing that these are not isolated circumstances. For example:

- a. Along the western side of the plan area, at the Valley–foothill interface, a tribal heritage landscape is still evident, based on anthropological literature and living Yokuts today.
- b. Numerous rock art outcrops are located in the western foothills.
- c. Large Native American archaeological sites have been repeatedly identified on the ground surface of actively cultivated areas. Some of these sites contained Native American human remains on the ground surface or embedded in the sidewalls of agricultural drains.

Tribal Recommendations

Staff's consultation with tribes identified several cultural resource management recommendations for planning renewable energy development in the plan area.

1. In the Valley and other areas long under cultivation, the present topography and condition of the landscape do not clearly predict the location of tribal and archaeological cultural resources. Tribes and local archaeologists, however, have found that the location of surficial and buried archaeological resources may be found in advance of project siting by:
 - a. Conducting archival research, particularly in historic topographic and survey maps that record the location of mounds, waterways, and water bodies that have since been leveled or filled for agricultural purposes;
 - b. Conducting archival research in local histories and anthropological notes, which can yield the locations of cultural resources;
 - c. Conducting ethnographic and oral history inquiries with tribal people to identify areas of cultural sensitivity; and
 - d. Avoiding areas with rock outcrops. Such features are often cultural resources themselves, and frequently surficial or buried archaeological deposits accompany rock outcrops.
2. Once cultural resources have been identified—whether through literature review, tribal oral history, or field methods—tribes recommend that all project components be sited with appropriate buffer areas from the known exterior boundaries of the resources. Appropriate buffers should be established in close consultation with affiliated tribes to avoid impacts to cultural resources. Ample

avoidance buffers take into account the size of many archaeological resources in the plan area (for instance, some Yokuts-affiliated archaeological sites measure 0.5 mile by 1.0 mile), the tendency for modern tillage of the soil to move artifacts, and the fact that surface artifact scatters do not always neatly correspond with buried archaeological deposits.

3. Tribes wish to develop “inadvertent discovery” burial agreements with lead agencies and solar developers prior to project construction.
4. Project avoidance of tribal cultural resources is preferable, where feasible.
5. Tribes request to be involved in project construction monitoring, as a form of mitigation measure, where avoidance is not feasible.
6. Decommissioning of renewable energy generation facilities, where applicable, must be conditioned to avoid damaging known cultural resources, require all project elements to be safely removed, and ensure that the land is restored to a natural state as much as practically possible.
7. Conservation easements in culturally sensitive areas may be an effective mitigation measure for impacts in other areas of tribal concern and may overlap with biological resource mitigation.
8. Communication with the correct tribal representatives is important for the respect of tribal sovereignty and the efficiency of the consultation process.
9. Of the 471,000 acres identified as least-conflict areas by the Solar Development, Environmental Conservation and Agricultural stakeholder groups, a total of 258,000 acres intersect Tribal Areas of Concern. According to the information available to Picayune Rancheria, Santa Rosa Rancheria, Table Mountain Rancheria, and Tule River Indian Reservation, solar development in these 258,000 acres have greater potential than the other least-conflict areas to affect tribal resources and interests.
10. Item 9 above highlights the importance of early consultation with tribes during future planning and project-specific development, as required under state and federal laws.
11. Solar development in the balance of least-conflict areas (213,000 acres) could still affect tribal resources or other cultural resources.



CONTEXT WITHIN THE SAN JOAQUIN VALLEY

Department of Defense Operational Areas

As urban development and renewable energy technologies expand into the Valley, this progress should occur in a compatible manner with existing and future military operations. A number of military operational areas (MOAs) are located in the San Joaquin Valley Solar Planning Area. These areas include instrument routes (IRs), slow routes (SRs), and visual routes (VRs) that are used by multiple military services located both inside and outside of the planning area. Table 5 describes each route and the military services that operate within them. A map of the operating areas is shown in Figure 16. The Naval Air Station Lemoore (NASL) is also located in the study area. Its principal mission is to support Strike-Fighter Wing, U.S. Pacific Fleet and its mission to train, man, and equip west coast Strike-Fighter squadrons. More information about NASL is available at: http://cnic.navy.mil/regions/cnrsw/installations/nas_lemoore.html.

The military, as a stakeholder utilizing air, sea, land, and frequency spectrum within various landscapes, will need to collaborate and coordinate with industry stakeholders, land use agencies, and the public. Without viable land management policies and proactive planning, uninformed actions taken by external stakeholders may adversely impact the military mission. The Regional Coordination Team in the Southwest, comprised of representatives from the military services, maintains a core objective of proactively protecting Department of Defense (DoD) military operational areas from incompatible land uses, policies, procedures, and regulations. The following diagram visually represents these elements of this core objective:

Early engagement with the military and external stakeholders provides the necessary awareness and education towards establishing policies, plans and procedures to promote compatibility with military operations while balancing economic prosperity, stewardship of the environment, and quality of life.

Contributed by Steve Chung
NRSW Regional CPL0

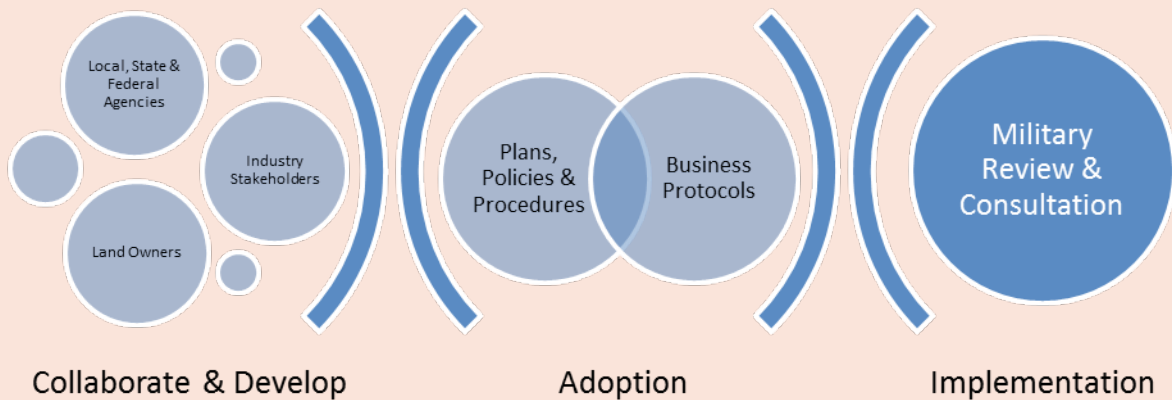

The military works with state and local governments and the public to plan for compatible land use and resource protection in areas potentially affected by military operations. Without collaboration, critical training and testing missions could be compromised.

To further collaborate between the military and local jurisdictions, Senate Bill 1462 (Kuehl, Chapter 906, Statutes of 2004) created a notification process to inform the military of local land use proposals that might have an impact on military facilities and operations in order to prevent land use conflicts with military installations and training activities. Specifically, the bill amended California Government Code Sections 65352(a)(6), 65404, 65940, and 65944(d)(1) and required local governments to:

- 1) Revise their development permit application forms to require identification of whether the proposed project is within 1,000 feet of a military installation, beneath a low-level flight path, or within special use airspace; and
- 2) Notify the military when a proposed project, or an updated or revised general plan, might have an impact on military facilities and operations. Such projects include wind turbines, meteorological “met” towers (to identify wind potential but typically not marked with lights to alert low-level aviators), solar energy facilities, cell towers, and geothermal plants.

Senate Bill 1468 (Knight, Chapter 971, Statutes of 2002) updated California Government Code Section 65302 (a)(2) to include consideration of impacts to the military’s operations in local government planning processes. The law states that the land use element of the General Plan: “shall consider the impact of new growth on military readiness activities carried out on military bases, installations, and operation and training areas, when proposing zoning ordinances or designating land uses covered by the general plan for land, or other territory adjacent to military facilities, or underlying designated military aviation routes and airspace.” Engagement includes the implementation of SB 1462 and SB 1468 through outreach and coordination of projects in and around military operation areas and installations.

| Military Ops Area (floor) | Owner or Common Name | Service | County |
|---------------------------|---|-------------------|---|
| IR203 (8000MSL) | Commander Strike FighterWing, US. Pacific Fleet, 001 (K) Street, Room 121, NAS Lemoore,CA 93246-5022 DSN 949-1034, C559-998-1034. | Navy | Kern |
| IR203 (11000MSL) | Commander Strike FighterWing, US. Pacific Fleet, 001 (K) Street, Room 121, NAS Lemoore,CA 93246-5022 DSN 949-1034, C559-998-1034. | Navy | Amador, Calaveras, Fresno, Madera, Mariposa, Merced, San Joaquin, Santa Clara, Stanislaus, Tulare, Tuolumne |
| SR300 (300AGL) | 60 OSS/OSO, 611 E. St., TravisAFB, CA 94535 DSN 837-5582, C707-424-5582. | Air Force | Calaveras, San Joaquin, Stanislaus |
| SR301 (300AGL) | 60 OSS/OSO, 611 E. St., TravisAFB, CA 94535 DSN 837-5582, C707-424-5582. | Air Force | Calaveras, San Joaquin, Stanislaus |
| VR1256 (200AGL) | Commander, Strike FighterWing, U.S. Pacific Fleet, 001 K Street, NAS Lemoore, CA93246-5022 DSN 949-1034 (1530-2400Z Mon-Fri),C559-998-1034. | Navy | Kern |
| VR1257 (200AGL) | Commander, Strike FighterWing, U.S. Pacific Fleet, 001 K Street, Rm 121, NAS Lemoore, CA93246-5022 DSN 949-1034, C559-998-1034. | Navy | Kern |
| VR1262 (200AGL) | Commander, Strike FighterWing, U.S. Pacific Fleet, 001 K Street, NAS Lemoore, CA93246-5022 DSN 949-1034 (1530-2400Z Mon-Fri),C559-998-1034. | Navy | Kern |
| VR1262 (1000AGL) | Commander, Strike FighterWing, U.S. Pacific Fleet, 001 K Street, NAS Lemoore, CA93246-5022 DSN 949-1034 (1530-2400Z Mon-Fri),C559-998-1034. | Navy | Kern |
| R2531 (Surface) | TRACY, CA | Navy | Alameda, San Joaquin |
| MOA US 01052 (2000AGL) | BAKERSFIELD MOA, CA | Navy | Kern |
| MOA US 01368 (2000AGL) | FOOTHILL 1 MOA, CA | Navy | Fresno |
| MOA US 01370 (2000AGL) | FOOTHILL 2 MOA, CA | Navy | Fresno, Tulare |
| MOA US 01665 (5000AMSL) | LEMOORE A MOA, CA | Navy | Fresno |
| MOA US 01666 (13000AMSL) | LEMOORE B MOA, CA | Navy | Fresno, Kings |
| MOA US 01667 (16000AMSL) | LEMOORE C MOA, CA | Navy | Fresno, Kings, Tulare |
| MOA US 01668 (5000AMSL) | LEMOORE D MOA, CA | Navy | Fresno, Kern, Kings |
| MOA US 01669 (5000AMSL) | LEMOORE E MOA, CA | Navy | Kern, Kings, Tulare |
| MOA US 01892 (2000AGL) | PORTERVILLE MOA, CA | Navy | Kern, Tulare |
| Military Airborne Radar | | Navy Air Force | Fresno, Kern, Kings, Madera, Mariposa, Merced, San Benito, Tulare |

TABLE 5. Description of Military Operational Areas in the SJV Planning Area.

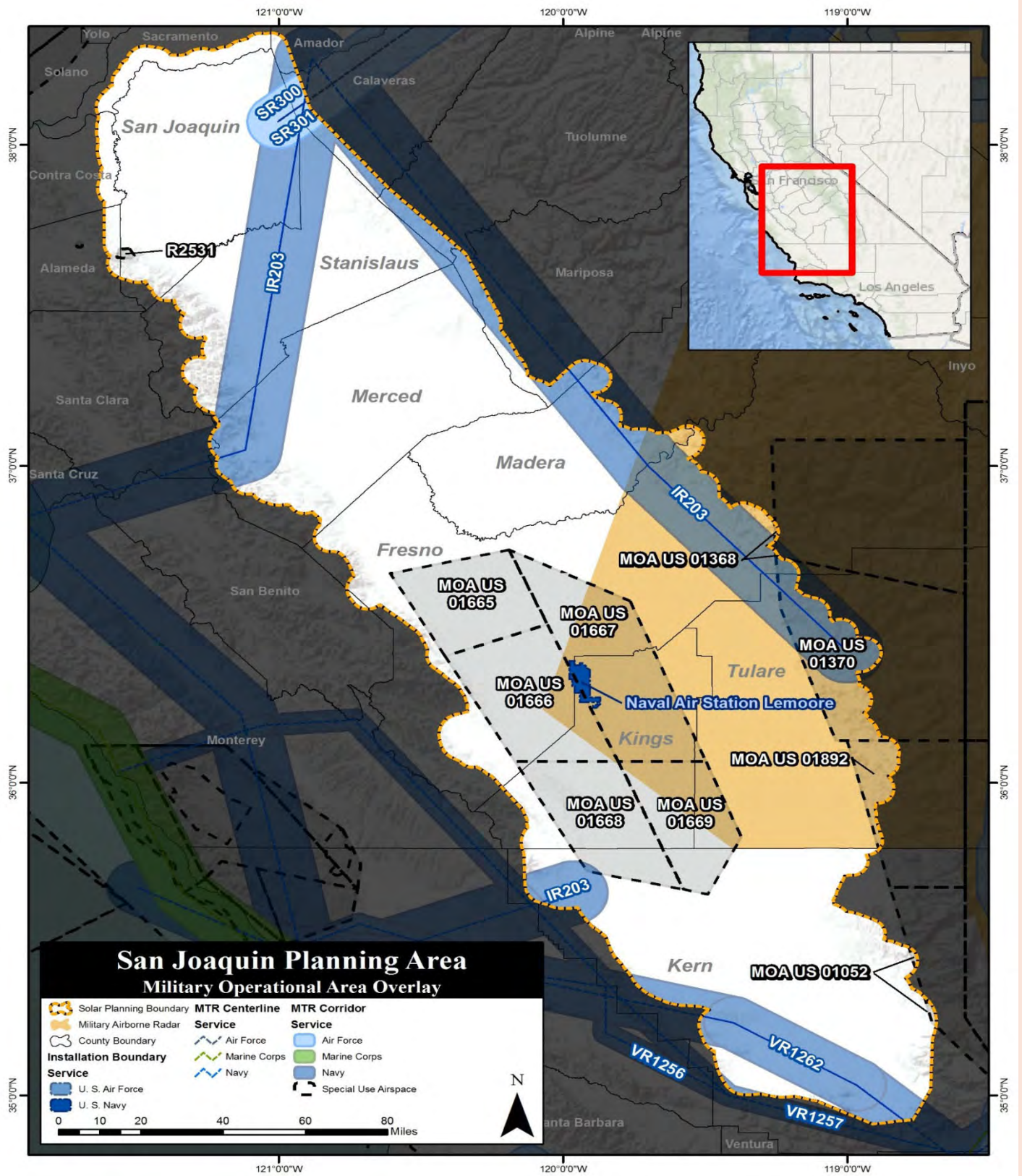

FIGURE 16. Military Operational Area intersects in the SJV Planning Area.



CONTEXT WITHIN THE SAN JOAQUIN VALLEY

Transmission in San Joaquin Valley

Transmission System

The transmission in the San Joaquin Valley is comprised of 500 kV, 230 kV, 115kV and 70 kV transmission circuits. Figure 17 illustrates the bulk transmission system in northern California, which covers the San Joaquin Valley. The northern portion of the San Joaquin Valley is located in the Pacific Gas and Electric (PG&E) service territory in Northern California. The southeastern portion of the San Joaquin Valley is located in the Southern California Edison (SCE) service territory.

The San Joaquin Valley area is interconnected to the bulk system through the PG&E 500 kV substations primarily at Midway, Gates and Los Banos, with underlying 230 kV transmission system interconnecting the local areas. The southeastern portion of the SCE 220 kV system in the Big Creek area connects to the southern 500 kV system. The PG&E and SCE 220 kV transmission systems are not interconnected. The northern and southern 500 kV systems are interconnected between the Midway and Vincent 500 kV substations.

Figure 18 provides a detailed illustration of 500 kV, 230 kV and 115 kV transmission circuits and substations within the identified boundaries of the San Joaquin Valley. The 500 kV bulk system runs along the west side of the San Joaquin boundary. The least-conflict areas identified in this report are also illustrated with respect to the area boundary and the transmission system.

*Contributed by Jeff Billinton
Manager, Regional Transmission-
North, CAISO*

This study has identified significant generation development potential in the San Joaquin Valley area where it would be best suited to fit into the



FIGURE 17. Bulk transmission system for northern California illustrating 500 kV, 230 kV, and 115 kV transmission circuits and substations within the identified boundaries of the San Joaquin Valley. The 500 kV bulk system runs along the west side of the San Joaquin boundary.

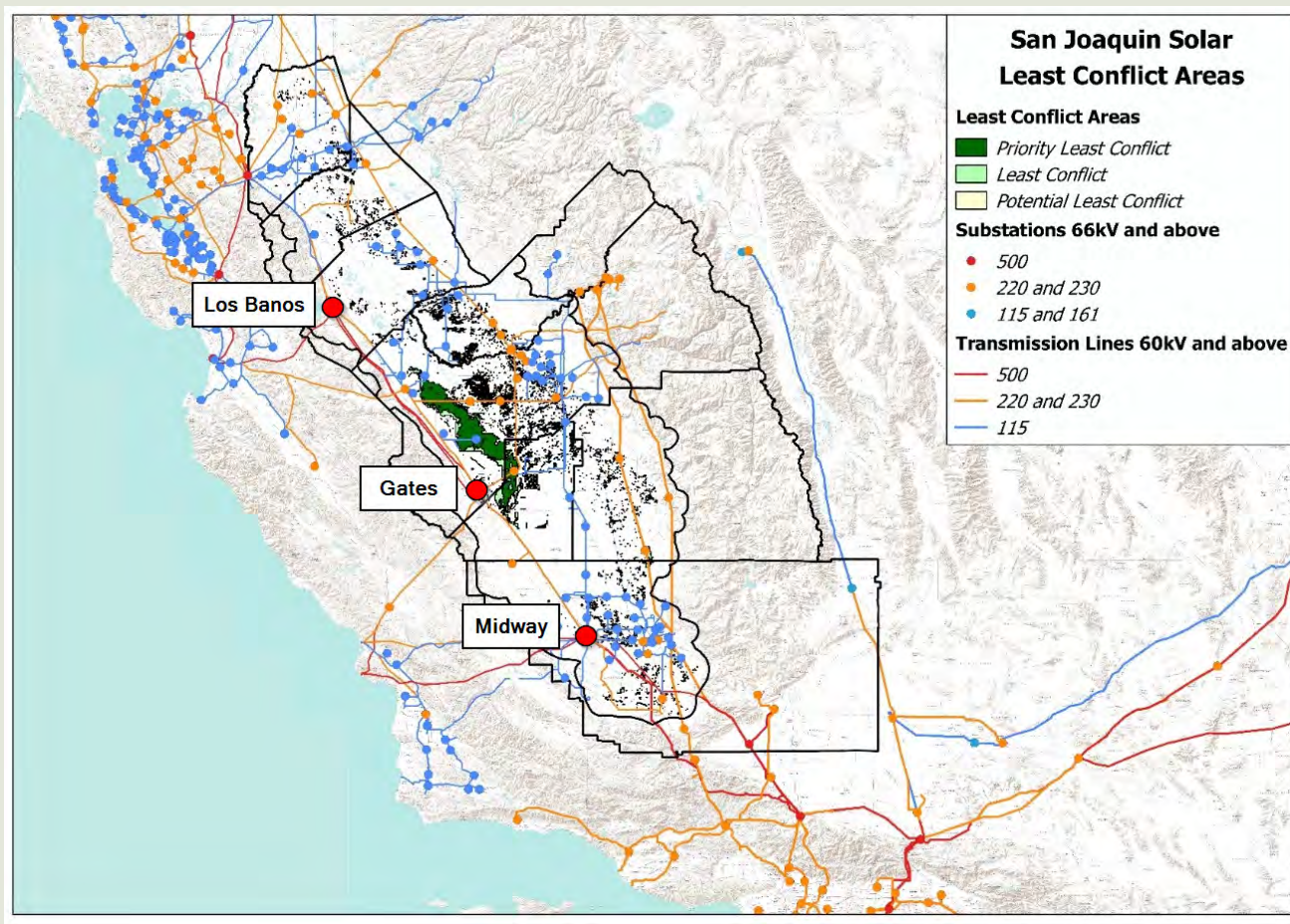

FIGURE 18. Existing transmission system in relation to the identified least conflict areas highlighting the three main substations in the region – Los Banos, Gates, and Midway.

existing land uses within the area. While there are smaller pockets of least-conflict lands identified throughout the San Joaquin Valley area, the largest area is located in the west central area of the San Joaquin Valley bordering adjacent to the 500 kV lines between the Gates and Los Banos substations.

Figure 19 provides a more detailed illustration of the transmission system in the primary least-conflict area that this process has identified. In addition to the identified bulk transmission (500 kV and 230 kV), local transmission systems (115 kV and 70 kV) also provide service, primarily to supply the loads in the area.

The detailed transmission system topology has not been included in the Data Basin datasets that have been developed as a part of this initiative; however, both PG&E and SCE provide detailed information on their websites for generation developers to identify geographically the transmission systems for potential interconnection of generation projects. The following provides links to the PG&E and SCE websites for these applications.

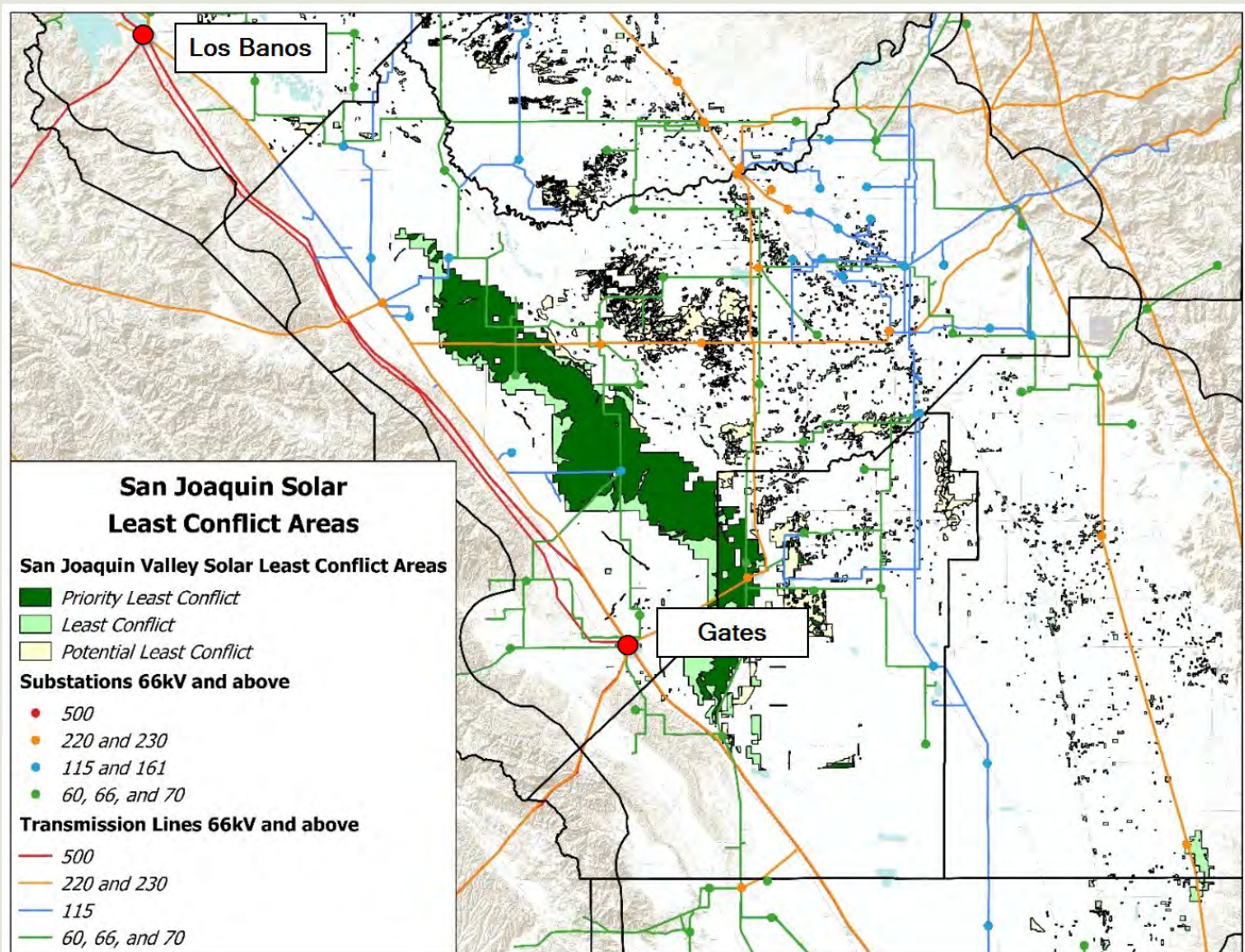

FIGURE 19. Existing transmission system in relation to the identified least conflict areas zoomed in between Los Banos and Gates substations.

- PG&E - Solar Photovoltaic (PV) and Renewable Auction Mechanism (RAM) Program Map www.pge.com/en/b2b/energysupply/wholesaleelectricssuppliersolicitation/PVRFO/pvmap/index.page
- SCE – Distributed Energy Resource Interconnection Map (DERiM) www.arcgis.com/home/webmap/viewer.html?webmap=e62dfa24128b4329bfc8b27c4526f6b7

Transmission Development and Capability

Transmission planning is a core responsibility of the California Independent System Operator (ISO). The ISO must identify and plan the development of solutions to meet the future needs of the ISO-

FIGURE 20. Existing transmission system in relation to the identified least conflict areas showing the Gates-Gregg Central Valley Power Connect

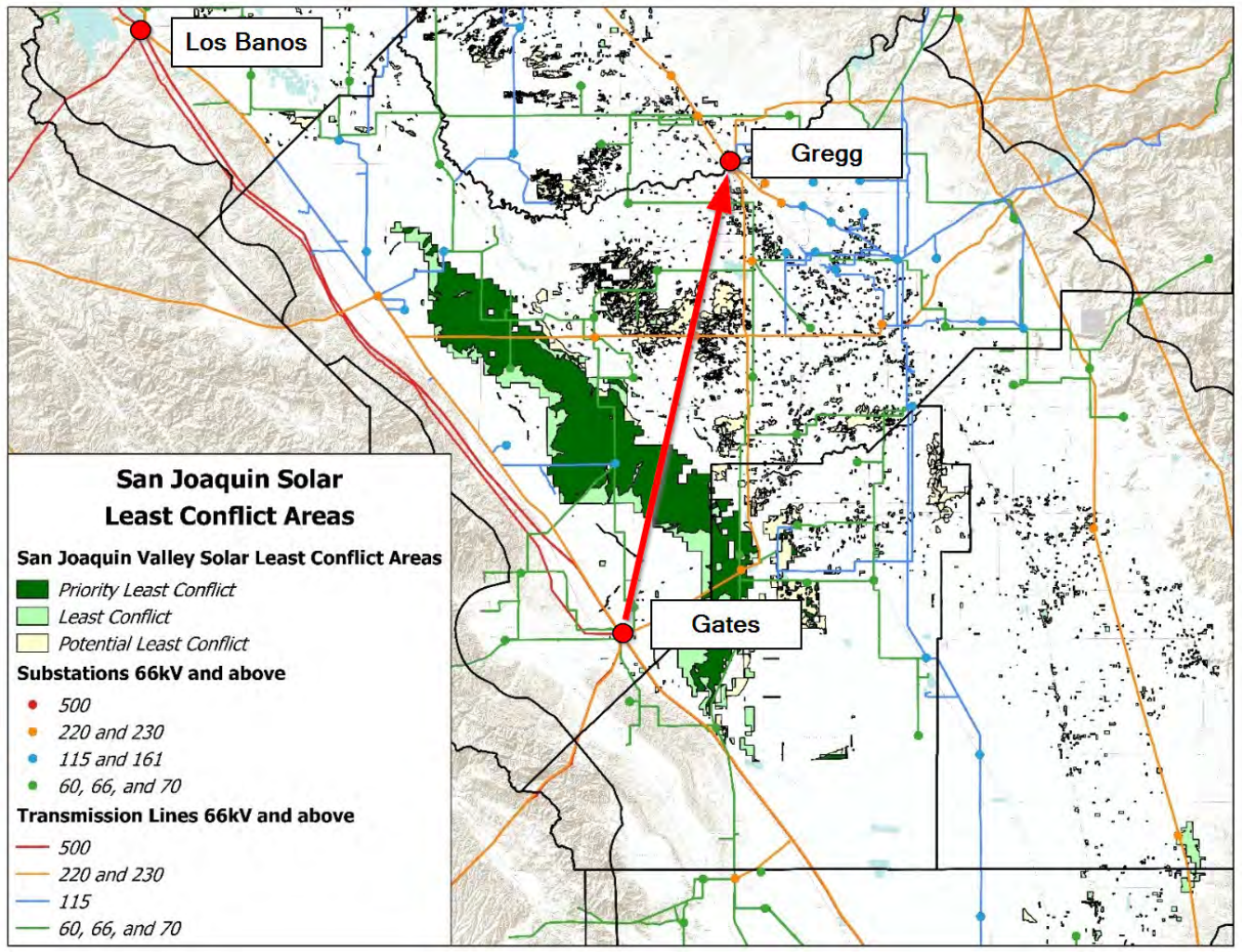

controlled grid, including the San Joaquin Valley area. Fulfilling this responsibility involves conducting an annual transmission planning process⁵⁹ (TPP) that culminates in the ISO Board of Governors (Board) approving a comprehensive transmission plan. The plan identifies needed transmission solutions and authorizes cost recovery through ISO transmission rates, subject to regulatory approval, as well as identifies other solutions that will be pursued in other venues to avoid building additional transmission facilities if possible. The plan is prepared in the larger context of supporting important energy and environmental policies and assisting in the transition to a cleaner, lower emission future, while maintaining reliability through a resilient electric system.

The plan primarily identifies needed transmission facilities based upon three main categories of transmission solutions: reliability, public policy and economic needs. The primary policy directive for the last four years

of the ISO planning cycles and the current cycle is California's Renewables Portfolio Standard, which calls for 33 percent of the electric retail sales in the state in 2020 to be provided from eligible renewable resources. The ISO formulates the public policy-related resource portfolios in collaboration with the California Public Utilities Commission (CPUC), with input from other state agencies such as the California Energy Commission (CEC) and the municipal utilities within the ISO balancing authority area. The CPUC plays a primary role in formulating the resource portfolios as the agency that oversees the supply procurement activities of the investor-owned utilities and retail direct access providers, which collectively account for 95 percent of the energy consumed annually within the ISO area.

The generation identified in the portfolios provided to help meet the 33 percent RPS requirement totaled 475 megawatts in the Westlands area, which is where stakeholders in this process identified the majority of the least-conflict areas in the Valley. In addition to the assessment of transmission to meet the 33 percent RPS policy requirements, the ISO has been coordinating with the CPUC to perform a special study in the 2015-2016 Transmission Planning Process. The special study is for information purposes only and will not be used to support a need for policy-driven transmission in the 2015-2016 planning cycle. The special study will provide information regarding the potential need for public policy-driven transmission additions or upgrades to support a statewide 50% renewable energy goal by 2030. It will also help inform the state's procurement processes about the cost impacts of achieving this goal. The special study is documented in the ISO 2015-2016 Transmission Plan.⁶⁰ The generation identified in the portfolios to go from 33 to 50 percent within the entire ISO-controlled area is in the order of magnitude of 12,000 MW.

A number of transmission developments have been identified and approved through the ISO transmission planning process. In particular, the 2012-2013 Transmission Plan identified development of multiple possible projects in the Central California area and approved the following reliability-driven projects, including:

- Gates-Gregg 230 kV Line (*Central Valley Power Connect*; Figure 20)
- Gates #2 500/230kV Transformer Addition
- Warnerville-Wilson 230kV Line Reactor
- Kearney-Hearndon 230kV Line Reconductoring

In addition to the reliability-driven projects identified above, the following projects are included in large generator interconnection agreements (LGIA) or approved as policy-driven projects in the ISO transmission planning process.

- Borden-Gregg 230 kV Reconductoring
- Warnerville-Bellota 230 kV Reconductoring
- Wilson-Le Grand 115 KV Reconductoring

FIGURE 21. Areas of generation interconnection requests in ISO queue.

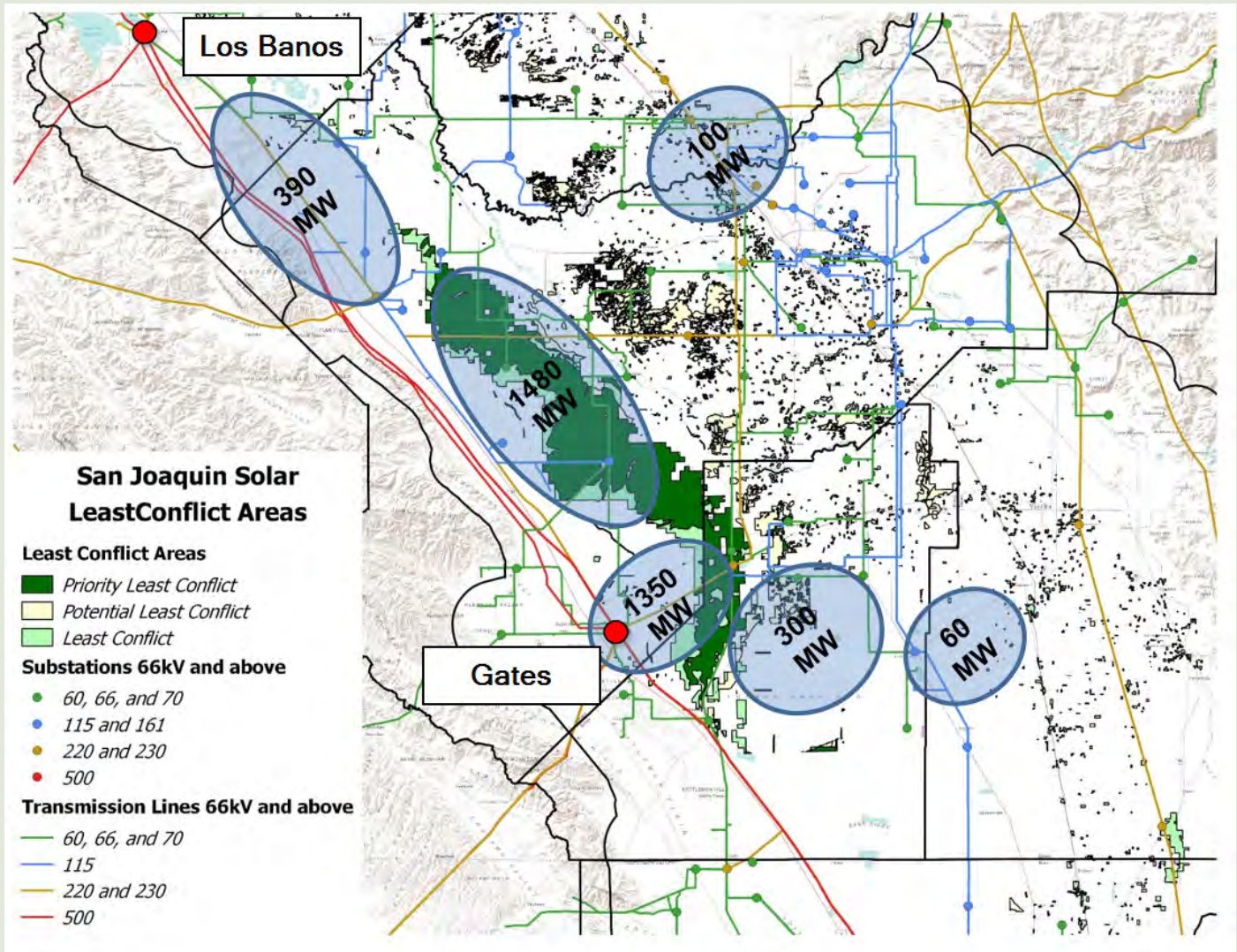

The Gates-Gregg 230 kV line (*Central Valley Power Connect*) was approved in the ISO 2012-2013 Transmission Plan to be constructed as a double circuit 230 kV transmission line.⁶¹ One side will be strung to facilitate future development requirements to supply load or integrate renewable generation in the area, while minimizing the future right-of-way requirements compared to single-circuit development.

While the need for the transmission was reliability-driven to supply the load in the areas and provide continued availability of the Helms Pumped Storage Plant, the projects also have policy-driven benefits for the area. The transmission development projects are scheduled to be in-service from 2018 to 2022. When the approved transmission projects identified above are in-service, the transmission capability of the system is in the 2,000 to 3,000 MW range. Depending on location and voltage of interconnection, additional local interconnection requirements may apply. The existing system can

FIGURE 22. Transmission development in the SCE area.

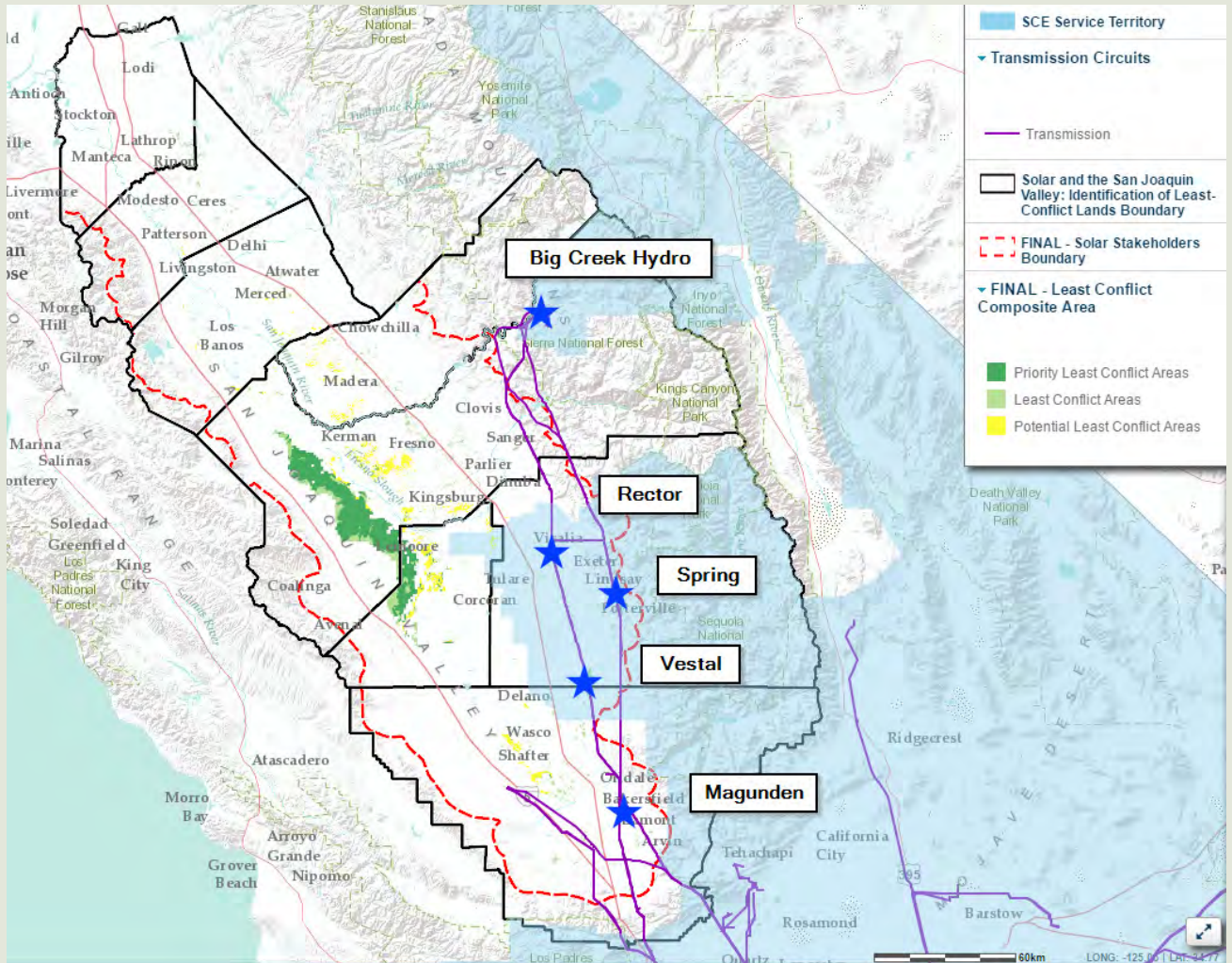

accommodate approximately 800 MW of generation interconnection in the area. The PG&E 115 kV and 70 kV systems in the local area have limited capacity and may require extensive upgrades to accommodate additional generation that interconnects to the lower voltage systems.

The generation connected to the transmission system in the identified least-conflict areas will either supply the load locally within the area or flow up onto the 500 kV system at either the Los Banos or Gates 500 kV substations. Flows into the 500 kV at Los Banos from potential generation development in the San Joaquin Valley would impact the 500 kV flows north of Los Banos effectively the same way as any generation development in Southern California. Similarly, the flows into the 500 kV at Gates from potential generation development in the San Joaquin Valley would impact the 500 kV flows south of Gates effectively the same as generation development in all of Northern California. Assessment through the ISO annual transmission planning process has not identified needs for transmission development either north of Los Banos, nor south of Midway to accommodate the identified generation development combinations.

The ISO administers the generation interconnection to the ISO-controlled grid through its FERC-approved tariff.⁶² Figure 21 illustrates the location of the current generation that is in the ISO Generation Interconnection Queue, with respect to the existing transmission system and the identified least-conflict lands. Approximately 3,380 MW of generator interconnection requests are located in pockets within the area as illustrated with additional individual generation interconnection requests located within isolated locations throughout the area.

The SCE transmission system in the San Joaquin Valley is located primarily along the eastern edge of the boundary area as illustrated in Figure 22. Two corridors from the Bakersfield area up to the Big Creek hydro area consist of two 220 kV single-circuit transmission circuits in each corridor. The existing system has limited additional interconnection capability due to thermal and stability limitations that require special protection systems (SPS) to mitigate contingency conditions. The ISO generation interconnection queue currently contains approximately 700 MW of generation. SCE reviewed the lines for potential options to increase the capacity of these lines. A copy of this assessment is included in Appendix C (see www.sjvp.databasin.org). Reconductoring these older low capacity 220 kV lines may be infeasible and could require rebuilding the lines with new, higher-capacity double circuit transmission lines.

Path Forward and Alternatives

California is currently on a trajectory to meet the 33 percent renewable energy mandate by 2020. The Clean Energy and Pollution Reduction Act of 2015 (SB 350) increased the RPS to at least 50 percent of retail sales and doubled the energy efficiency savings required by 2030.

RETI 2.0

To facilitate electric transmission coordination and planning, the California Energy Commission, the California Public Utilities Commission, and the California Independent System Operator have initiated the Renewable Energy Transmission Initiative 2.0, also known as RETI 2.0.⁶³ The objectives of RETI 2.0 are:⁶⁴

- Launch a statewide, non-regulatory planning effort to help meet statewide greenhouse gas and renewable energy goals;
- Explore combinations of renewable generation resources in California and throughout the West that can best meet these goals;
- Identify land use and environmental opportunities and constraints to accessing these resources;
- Build understanding of transmission implications of renewable scenarios and identify common transmission elements; and
- Inform future planning and regulatory proceedings.

Within the RETI 2.0 organizational structure, two technical groups (the Environmental and Land Use Technical Group and the Transmission

Technical Input Group) have been formed with stakeholder meetings underway. The work of the Transmission Technical Input Group will characterize the existing transmission and provide initial transmission input on developments necessary to access potential renewable generation as combinations of renewable resources are developed.

“Garamendi Principles” and Corridor Planning

Senate Bill 2431 (Garamendi, Statutes of 1988) recognized the value of the transmission system and the need for coordinated long-term transmission corridor planning to maximize the efficiency of transmission rights-of-way and avoid single purpose lines. Specifically, findings to SB 2431, commonly referred to as the Garamendi Principles, identified that the planning and siting of new transmission facilities should be pursued in the following order:

1. Encourage the use of existing rights-of-way (ROW) by upgrading existing transmission facilities where technically and economically feasible.
2. When construction of new transmission lines is required, encourage expansion of existing ROW, when technically and economically feasible.
3. Provide for the creation of new ROW when justified by environmental, technical, or economic reasons defined by the appropriate licensing agency.
4. Where there is a need to construct additional transmission capacity, seek agreement among all interested utilities on the efficient use of that capacity.

Senate Bill 1059 (Escutia and Morrow, Chapter 638, Statutes of 2006) linked transmission planning and permitting by authorizing the CEC to designate transmission corridor zones on non-federal lands to allow for the timely permitting of future high-voltage transmission projects, with the further requirement that any corridor proposed for designation must be consistent with the state’s needs and objectives as identified in the latest adopted strategic transmission investment plan.

With regard to corridors that would be suitable for designation by the CEC, the *2015 Integrated Energy Policy Report (IEPR)* references previous work from the *2013 IEPR and Strategic Transmission Investment Plan*, noting that:

“From a timing perspective, it makes sense to identify and designate, where appropriate, transmission corridors in advance of future generation development so that needed transmission projects can be permitted and built in an effective, environmentally responsible manner, contemporaneous with the generation development. The CEC will work with the utilities; federal, state, and local agencies; and stakeholders to identify transmission line corridors that are a high priority for designation such as those corridors that would

ease the development of renewable energy resources. Appropriate corridors could be identified as a result of the *Desert Renewable Energy Conservation Plan*, future examination of opportunities and needs in the San Joaquin Valley (southern area of the Central Valley), and the ongoing San Onofre transmission alternatives under consideration."⁶⁵

Based upon the outcomes of the RETI 2.0 and development of the portfolios to meet the 50 percent RPS goals, transmission alternatives to support long term potential considerations of generation development in the least-conflict areas beyond the existing capability of 2,000 to 3,000 MW in the San Joaquin Valley and to promote system reliability could include the following:

- Opportunities for reconductoring existing transmission lines;
- Opportunities for new transmission lines utilizing existing corridors; and
- Opportunities for right-sizing new transmission lines.

Additionally, RETI 2.0 provides an important opportunity to understand environmental, land use, and transmission constraints and opportunities related to a variety of conceptual resource combinations, potential common transmission elements, and plausible high-priority corridors to help expedite long-term transmission planning goals.



CHALLENGES AND RECOMMENDED SOLUTIONS

Throughout this process, stakeholders have expressed interest in identifying challenges and offering solutions to improve solar PV and transmission development in the San Joaquin Valley. The following sections summarize some of the challenges and solutions identified by the stakeholders. Many of the challenges listed are common throughout the region and many parts of the state, but the solutions are focused on incentivizing solar PV development specifically on the identified least-conflict lands.

Challenge: Lack of transmission capacity serving the San Joaquin Valley

Electricity transmission capacity serving the San Joaquin Valley was generally not sized until recently to transmit power from utility-scale generators in the Valley to consumers hundreds of miles away. This lack of capacity was partly due to the agricultural nature of the Valley economy, coupled with generally low population density across its 11,000 square miles, which results in relatively small electricity demand compared to other areas of the state that rely more on industrial production.⁶⁶ Early in the process, the majority of stakeholders repeatedly cited the perception of a lack of available transmission capacity as a major limiting factor in accommodating more renewable energy production from the Valley for use in other parts of the state.

At the final stakeholder convening, participants identified the lack of transmission and the timing, cost, and uncertainty of future transmission development as a significant impediment to solar development in the San Joaquin Valley generally, let alone in least-conflict lands. The ISO believes that the approved transmission projects (discussed in the ISO transmission planning process section) will provide transmission capacity in the least-conflict land areas within the 2000 to 3000 MW range.

According to stakeholders, two major factors continue to create significant barriers for transmission in the Valley:

1. The Generator Interconnection Process and queue process has recognized interconnection costs for generation developers in the area. These upgrades are typically related to the ones required to interconnect the generators to the local lower voltage (70 kV and 115 kV) system in the area. Beyond the 2000 to 3000 MW capacity discussed above, additional transmission development may be required.
2. State policy makers have included relatively low generation capacities in the Valley to date. This low capacity originated in the CPUC and CEC-developed RPS portfolios, using the CPUC RPS calculator, which the agencies submitted to the ISO. The ISO then used these portfolios in its transmission planning process to identify transmission needs to meet the state's RPS goals.

Upgrading nearby transmission lines can be expensive, and the upgrades identified in the ISO generator interconnection process will need to be financed upfront by developers, although these costs are eventually passed along to ratepayers after the generators interconnect to the system.

Stakeholders noted that significant advancements to the existing transmission grid may be required. The optimal transmission solutions to unlock the solar potential of the San Joaquin Valley will need to be scalable to address both current and potential future development, while maintaining and enhancing local reliability. Stakeholders noted that solutions should include upgrading local level and bulk transmission systems, as well as constructing new or upgraded backbone transmission facilities. Stakeholders understood that while upgrades to local level systems will largely depend on the specific locations of future solar projects, backbone system upgrades could begin now.

Possible Solution

Stakeholders felt that transmission should be prioritized to least-conflict areas. Transmission planners should incorporate identified generation development potential in least-conflict areas in the San Joaquin Valley into their process, along with potential transmission alternatives, such as upgrades to existing transmission facilities or “right sizing” of new transmission facilities to accommodate these needs and expected long-term future needs.

According to stakeholders, a comprehensive transmission plan is critical to supporting the development of large-scale solar in the San Joaquin Valley, as occurred with similar transmission plans previously developed to unlock the wind potential in the Tehachapi Mountains. RETI 2.0 and CPUC regulatory processes will develop future transmission planning assessments to meet state renewable goals and will incorporate the generation capacities that could be developed in the San Joaquin Valley. These potential generation capacities will be utilized within transmission planning studies to identify the transmission needs to accommodate these capacities.

If a need for transmission development to meet the planned-for generation capacity is identified, transmission planners and transmission developers should consider the size and design of these facilities to take advantage of economies of scale and to accommodate expected future growth in transmission capacity demand. This process is sometimes referred to as “right sizing”⁶⁷ and prevents having to site and build new parallel transmission lines within a few years, after the capacity of the previously built transmission line proves inadequate.⁶⁸ A right-sized project can reduce future costs and environmental impacts of transmission development. This is similar to the approach for the Gates to Gregg 230 kV line project (also called Central Valley Power Connect) approved through the ISO transmission planning process: the 230 kV line is to be constructed as a double-circuit transmission line, with only one of the circuits initially strung to satisfy the currently identified need. The second circuit can be strung when there is a need for additional capacity, without requiring additional rights-of-way for the additional transmission line to be constructed. The California Energy Commission’s *2015 Integrated Energy Policy Report* recommends that the state develop right-sizing definitions and policies in 2016 that are informed by RETI 2.0.⁶⁹ For financing, although California has experience with utility securitization with all three of its investor-owned utilities,⁷⁰ private funding for building transmission may not be sufficient to build the necessary lines for renewable energy. In order to achieve the state’s 50 percent renewable energy goal by 2030, California ratepayers may need to bear the costs of upgrading and deploying transmission lines upfront.

Stakeholders recommended a comprehensive planning exercise supported by the CEC, CPUC and the ISO to identify and plan for the near-term development of renewable generation to meet the state’s renewable goals, which would include solar PV in the San Joaquin Valley and target least-conflict lands. The CPUC and CEC should recognize the environmental, economic, and public policy benefits of a large amount of solar in the San Joaquin Valley as part of its next update for statewide renewable portfolios. These portfolios would be submitted to the ISO to be used in the annual transmission planning process to identify, beyond the existing and identified planned system capabilities, the additional transmission needs to accommodate the statewide renewable portfolios. If transmission development is determined to be necessary to accommodate the identified generation in the San Joaquin Valley area to meet the state’s renewable goals, potential upgrades to existing transmission facilities, the use of existing corridors, and the “right sizing” of new transmission facilities should be considered to accommodate current needs as well as expected longer-term future needs.

Challenge: High solar PV permitting uncertainty and complexity, along with large soft costs associated with siting, deployment, operations and mitigation.

Significant costs occur through the planning and deployment phases of solar PV projects, requiring developers to maintain a buffer to account for

contingencies.⁷¹ Mitigating the impacts of projects can also be costly, as the plans have to be adopted and implemented in accordance with both federal and state laws in order to address impacts on wildlife conservation and environmental protection.⁷² Mitigation based on anticipated environmental impacts, coupled with uncertainties pertaining to mitigation planning, pose significant challenges for solar PV development projects in all areas.

Developers also need to plan and prepare for the decommissioning of the installation after it has completed its useful and contractual life, including establishing decommissioning funds or trusts in order to finance the decommissioning and restoration of the land.

Possible Solution

Coordinating solar PV development, permitting, and mitigation with federal, state, and local agencies and receiving input from developers and stakeholders throughout the process.

Taking a landscape-scale approach to planning, permitting, and mitigation can improve permitting efficiencies, reduce conflicts and costs, and better achieve both development and conservation objectives. Federal, state and local agencies should work together with solar and transmission developers and other stakeholders to develop a more strategic, regional conservation permitting and mitigation process founded on the best available science and habitat conservation planning principles. Such an approach has potential to reduce permitting costs as well as costs associated with mitigation requirements. It can also lay a foundation for tiered permitting by federal, state and local agencies. In addition, agencies, developers, stakeholders, and Tribal governments should continue working together to understand each other's issues and areas of concern ahead of new project proposals, in order to avoid or reduce potential impacts going forward.

This type of programmatic permitting can reduce mitigation requirements, where appropriate and when preceded by a landscape-scale approach and/or by off-site pre-mitigation. Reduced mitigation requirements are probably more appropriate on least-conflict lands than on any other lands. Some projects in these areas may even be worth exempting from some or all mitigation requirements.

Central to this approach is the inclusion of local governments in the planning process. Many local governments would also benefit from dedicated funding for planning for renewables in least-conflict areas. Given their land use authority and role in environmental pre-clearance and advance mitigation, counties will need funds for advance planning and upfront environmental review. State funds could support this local effort.

Challenge: Lack of agreement concerning solar PV compatibility with agricultural and habitat values.

Some stakeholders suggested that solar PV development may be compatible

with agricultural uses and species habitat, provided the development is completed according to best practices on installation and configuration. However, there is uncertainty regarding the overall market potential, rural economic development capability, and specific solar configurations that may be compatible with agricultural and habitat values. Due to the recent growth of the industry, little long-term data exist regarding the environmental impacts of solar PV. Solar PV projects may be compatible with habitats for some species and with some forms of agriculture, particularly livestock grazing. However, the scarcity of sufficient long-term surveys and appropriately vetted information stands in the way of broad acceptance of solar compatibility with some agricultural and habitat values.

Solution

Solar development project studies with survey information on impacts and potential compatibility as a result of construction and operations-related best practices need to be compiled, vetted, shared and ultimately housed centrally by a state authority.

A recent study initiated in October of 2015 may offer a promising approach. *Meeting SunShot Cost and Deployment Targets through Innovative Site Preparation and Impact Reductions on the Environment (InSPIRE)* by NREL, the solar industry, and other stakeholders demonstrated opportunities for cost reductions and higher levels of deployment of solar technologies through low environmental impact designs and approaches. The project is intended to provide a comprehensive assessment of baseline costs, cost reduction strategies, and environmental impact reduction strategies for solar technologies in three areas:

- Low-impact site preparation practices for ground-mounted solar PV projects;
- Siting solar projects on contaminated and marginal lands; and
- Co-locating solar projects on agricultural lands.

In addition, an organized dialogue between the solar industry, agricultural practitioners, and the environmental/conservation community could provide a productive forum to identify other project studies and surveys that could shed additional light on the potential compatibility of these uses and values.

Challenge: Lands enrolled in the Williamson Act that may no longer be agriculturally productive or providing suitable open space habitat for species.

California's Williamson Act was conceived in the mid-1960s to keep agricultural land from being converted to urban land uses. The act provides property tax relief for agricultural and open-space property owners through automatically renewing ten- or twenty-year contracts, in return for their pledge to keep the land use unchanged. Williamson Act contracts may primarily be terminated by non-renewal, which is a lengthy process,

or by cancellation, which entails a highly uncertain multi-level permitting process and significant costs.⁷³

Because some least-conflict land may be under Williamson Act protection, the law may be inadvertently encouraging development on lands of high agricultural value that don't have significant Williamson Act protections, while discouraging development on marginal lands under purview of the law. For example, with California's enduring drought and ensuing water scarcity, agricultural use of certain lands may not be feasible or ecological in the foreseeable future. Yet the land use limitations of the Williamson Act still apply to some of these lands.

Solution

Alteration to SB 618 "solar easements" on Williamson Act land and revision of Williamson Act cancellation process

Some stakeholders advocated the full utilization of renewable energy-specific tools for the interim management of Williamson Act contracts, such as Senate Bill 618 (Wolk, Statutes of 2011, Chapter 596). SB 618 enables the parties to a Williamson Act or Farmland Security Zone contract to rescind this contract in its entirety or in part in order to simultaneously enter into a solar-use easement, requiring the land to be used for solar photovoltaic facilities for a term of 20 years or not shorter than 10 years. Other stakeholders suggested that additional cross-stakeholder group discussion is warranted to explore potential additional solutions.



CONCLUSION

“The San Joaquin Valley Least-Conflict process has demonstrated the effectiveness of collaborative planning with stakeholder leadership, multi-agency advisory support, and a commitment to transparency in the use of environmental and land use data and analyses. This process certainly demonstrated that there are significant opportunity areas for solar development in the San Joaquin Valley that were viewed as composite “least conflict” by participating stakeholder groups. Just as importantly, it documents why the process came out as it did for the benefit of all of those who wish to understand the work done here or to build on it.”

- Karen Douglas, Commissioner, California Energy Commission

The San Joaquin Valley process resulted in a credible snapshot of significant least-conflict lands for solar PV development. But it also underscores the remaining complex issues that warrant additional conversation, if the Valley is to realize its full potential as part of California’s renewable energy future. These issues include how best to balance renewable energy interests with agricultural interests and conservation of wildlife and natural communities in a rapidly changing environment. This effort is therefore just a start. The opportunity remains to continue the conversation and act on consensus recommendations that can simultaneously protect sensitive wildlife, conserve farmland, and help meet California’s renewable energy goals while promoting economic development in the San Joaquin Valley.

Full Stakeholder List

Stakeholder Group Participants

Ileene Anderson, Center for Biological Diversity
Erica Brand, The Nature Conservancy
Jennifer Buck-Diaz, California Native Plant Society
Scott Butterfield, The Nature Conservancy
Dick Cameron, The Nature Conservancy
Shelby Semmes, The Trust for Public Land
Mary Creasman, The Trust for Public Land
Stephanie Dashiell, The Nature Conservancy
Kim Delfino, Defenders of Wildlife
Sarah Friedman, Sierra Club
Garry George, Audubon California
Dan Gluesenkamp, California Native Plant Society
Kate Kelly, Defenders of Wildlife/Consultant
Katie Krieger, Audubon California
Liling Lee, Audubon California
Adam Livingston, Sequoia Riverlands Trust
Gordon Nipp, Sierra Club
Helen O'Shea, Natural Resources Defense Council
Greg Suba, California Native Plant Society
Sam Young, Swaim Biological
Carl Zichella, Natural Resources Defense Council

Goran Arya, Eon Energy
Chris Baker, Sun Power
Scott Busa, Next Era Energy
Jim Detmers, Consultant/Former CAISO ED
Lars Dorr, Clenera Energy
Bob Dowd, Consultant
Shannon Eddy, Large Solar Association
Tom Eisenhauer, Renewable Group
Chris Ellison, Ellison, Schneider & Harris
DaVina Flemings, Pacific Gas and Electric
Rachel Gold, Large Solar Association
Jesse Gronner, Iberdrola Renewables
Catherine Hackney, Southern California Edison
Katherine (Katie) Hoffmaster, Next Era Energy
Seth Israel, Recurrent Energy
Ray Kelly, NRG
Tim Lasocki, Sun Edison
Julia Ma Powers, Crowell & Moring
Jess Meilin, Next Era Energy
Marisa Mitchell, Recurrent Energy
Frances Mizuno, San Luis & Delta Mendota Water Authority
John Pimentel, PV2 Energy
Jon Reiter, Maricopa Orchards
Jeffrey Roberts, Granville Homes/Maricopa Orchards/Assemi Group

Renee Robin, SunPower
Diane Ross-Leech, Pacific Gas and Electric
Roy Skinner, First Solar
Al Solis, Development
Alex Sundquist, 8 Minute Energy
Curtis Uptain, Quad Knopf
Peter Weiner, Paul Hastings LLP
V. John White, Center for Energy Efficiency and Renewable Technologies
James Woodruff, First Solar
Byron Woertz, Jr., Western Electricity Coordinating Council
Tehya Wood, Center for Energy Efficiency and Renewable Technologies
John Woolard, Google

Andy Aston, Clenera Energy
Steve Black, Consultant
Justin Bieber, Pacific Gas and Electric
Brian Boroski, H.T. Harvey & Associates
John Cupparo, Mid American Transmission
Sony Dhaliwal, Pacific Gas and Electric
Eric Eisenman, Pacific Gas and Electric
Chris Ellison, Ellison, Schneider & Harris
Spencer Hanes, Duke - American Transmission
Jon Jensen, Western Electricity Coordinating Council
Kevin Johnson, TransCanyon
Chris Jones, Duke - American Transmission
Daniel Kim, Westlands Solar Park
Josh Martin, Westlands Solar Park
Brian McDonald, Pacific Gas and Electric
Patrick Mealoy, Consultant
Anupamu Pandey, Pacific Gas and Electric
Kevin Richardson, Southern California Edison
Marco Rios, Pacific Gas and Electric
Diane Ross-Leach, Pacific Gas and Electric

Neema Assemi, Maricopa Orchards/Assemi Group
Theresa Becchetti, University of California Merced Cooperative
Michael Boccadoro, West Coast Advisors
Matt Byrne, California Cattlemens Association
Michael Delbar, California Rangeland Trust
Russ Freeman, Westlands Water District
John Gamper, California Farm Bureau Federation
John Garamendi, Jr., Professional Evaluation Group
Billy Gatlin, California Cattlemens Association
Brian Grant, Bolthouse Farms
Sargeant Green, California State University, Fresno
Ryan Jacobsen, Fresno County Farm Bureau
Virginia Jameson, American Farmland Trust
Bill Martin, Central Valley Farmland Trust
Lynne McBride, California Dairy Campaign, California Farmers Union
Karen Mills, California Farm Bureau Federation

Mike Ming, Alliance Appraisal
Jean Okuye, East Merced Resource Conservation District
Justin Oldfield, California Cattlemens Association
Tom Orvis, Stanislaus County Farm Bureau
Karen Sweet, California Rangeland Conservation Coalition
Ed Thompson, American Farmland Trust
Anthony Toso, Edwards, Lien & Toso, Inc.
David Zoldoske, California State University, Fresno

Agency Advisors

Jana Affonso, United States Fish and Wildlife Service
Ken Alex, Governor's Office of Planning and Research
Keoni Almeida, California Independent System Operator
Al Alvarado, California Energy Commission
Jim Bartridge, California Energy Commission
Jeff Billinton, California Independent System Operator
Elaine Blok, United States Fish and Wildlife Service
Mariana Brown, United States Navy
D Bunn, California Department of Conservation
Chris Calfee, Governor's Office of Planning and Research
Matt Chalmers, California Energy Commission
Stuart Chan, California Department of Water Resources
Steve Chung, United States Navy
Dan Cox, United States Fish and Wildlife Service
DeeDee D'Adamo, State Water Resources Control Board
JR DeLaRosa, California Natural Resources Agency
Chi Doan, California Department of Water Resources
Karen Douglas, California Energy Commission
Scott Flint, California Energy Commission
Bill Forsythe, California Department of Water Resources
Rebecca Fris, United States Fish and Wildlife Service
Melanie Gogol-Prokurat, California Department of Fish and Wildlife
Denny Grossman, Strategic Growth Council
Rito Guerra, Governor's Office of Planning and Research
Thomas Heinzer, United States Bureau of Reclamation
Tiffany Heitz, United States Fish and Wildlife Service
Bronwyn Hogan, United States Fish and Wildlife Service
Kevin Hunting, California Department of Fish and Wildlife
Connie Latham, California State Parks
Tracey A. LeBeau, Western Area Power Administration
Jenny Lester Moffitt, California Department of Food and Agriculture
Pat Lineback, United States Fish and Wildlife Service
John Lowrie, California Department of Conservation
Tom Lupo, California Department of Fish and Wildlife
Jason Marshall, California Department of Conservation
Neil Millar, California Independent System Operator
Scott Morgan, Governor's Office of Planning and Research
Jennifer Nelson, California Energy Commission
Jennifer Norris, United States Fish and Wildlife Service
Conor O'Brien, California Department of Food and Agriculture

Dennis Peters, California Independent System Operator
Holly Roberson, Governor's Office of Planning and Research
Nate Roth, California Department of Conservation
Lara Rozzell, National Park Service
Kenneth Sanchez, United States Fish and Wildlife Service
Barbara Simpson, United States Bureau of Reclamation
Scott Springer, United States Bureau of Reclamation
Robert Tse, United States Department of Agriculture
Brian Turner, California Public Utilities Commission
Julie Vance, California Department of Fish and Wildlife

County Advisors

Norman Allinder, Madera County
Angela Freitas, Stanislaus County
Rick Griffin, San Joaquin County
Andy Horne, Imperial County
Bernard Jiminez, Fresno County
Oksana Newmen, Merced County
Lorelei Oviatt, Kern County
Tim Snellings, Butte County
Kerry Sullivan, San Joaquin County
Clark Thompson, Fresno COG
Michael Washam, Tulare County

Other Attendees

Audra Hartmann, Smith, Watts & Hartmann - Consulting and Lobbying
Betony Jones, UC Berkeley
Rey Leon, Valley Leap
Rhonda Mills, Center for Energy Efficiency and Renewable Technologies
Rhett Winterton, Precision Civil Engineering
Lydia Zabrycki, Precision Civil Engineering

Endnotes

- 1 SB 350, De León, Statutes of 2015. Clean Energy and Pollution Reduction Act of 2015. Available at: https://leginfo.legislature.ca.gov/faces/billNavClient.xhtml?bill_id=201520160SB350 (accessed March 5, 2016).
- 2 H. R. 2029 - Consolidated Appropriations Act, 2016. Available at: <https://www.congress.gov/bill/114th-congress/house-bill/2029/text> (accessed March 5, 2016).
- 3 Forrest Melton et al., “Fallowed Area Mapping for Drought Impact Reporting: 2015 Assessment of Conditions in the California Central Valley,” 2015. Available at: https://nex.nasa.gov/nex/static/media/other/Central_Valley_Following_Data_Report_14Oct2015.pdf (accessed March 5, 2016).
- 4 Brian L. Cypher, Scott E. Phillips, and Patrick A. Kelly, “Quantity and distribution of suitable habitat for endangered San Joaquin kit foxes: conservation implications,” *Canid Biology & Conservation* 16(7), 2013, pp. 25-31. Available at: http://www.canids.org/CBC/16/san_joaquin_kit_fox_habitat_suitability.pdf (accessed March 5, 2016).
- 5 Kate Kelly and Kim Delfino, “Smart from the Start: Responsible Renewable Energy Development in the Southern San Joaquin Valley,” 2012. Available at: http://www.defenders.org/sites/default/files/publications/smartfromthestartreport12_print.pdf (accessed March 5, 2016). See also H. Scott Butterfield et al., “Western San Joaquin Valley least conflict solar assessment. Unpublished report,” 2013. Available at http://scienceforconservation.org/dl/WSJV_SolarAssessment_2013.pdf (accessed March 5, 2016).
- 6 Recommendations at the end of the tribal section will assist agencies, stakeholders, and industry to understand tribal concerns and points of view.
- 7 California Energy Commission, “Tracking Progress,” December 22, 2015. Available at: http://www.energy.ca.gov/renewables/tracking_progress/documents/renewable.pdf (accessed March 5, 2016).
- 8 Id.
- 9 Id.
- 10 U.S. Energy Information Administration website, “Short Term Energy Outlook - Renewables and CO2 Emissions,” March 2016. Available at: https://www.eia.gov/forecasts/steo/report/renew_co2.cfm (accessed March 5, 2016).
- 11 See Sean Ong. Clinton Cambell. Paul Denholm. Robert Margolis. Garvin Heath, “Land-Use Requirements for Solar Power Plants in the United States,” June 2013. Available at: <http://www.nrel.gov/docs/fy13osti/56290.pdf> (accessed March 5, 2016).
- 12 Assuming low PV figure of 6 acres/MWac.
- 13 Energy.gov – Office of Energy Efficiency and Renewable Energy website, “Sunshot Initiative.” Available at: <http://energy.gov/eere/sunshot/sunshot-initiative> (accessed March 5, 2016).
- 14 Data Basin website, “90 m DEM of California, USA.” Available at: <http://databasin.org/datasets/78ac54fabd594db5a39f6629514752c0> (accessed March 5, 2016).
- 15 Data Basin website, “PAD-US (CBI Edition) Version 2.1, California.” Available at: <http://databasin.org/datasets/5f0fc3cea52146178b44033f6f47587a> (accessed March 5, 2016).
- 16 Greeninfo Network website, “California Protected Areas Data Portal.” Available at: <http://www.calands.org/> (accessed March 5, 2016).
- 17 U.S. Geological Survey website, “Critical Habitat, Pacific Southwest Region 8.” Available at: <https://www.sciencebase.gov/catalog/item/55439cdf64b0a658d7941606> (accessed March 5, 2016).
- 18 Data Basin website, “California Department of Fish and Wildlife (CDFW) Owned and Operated Lands, Generalized Version.” Available at: <http://sjvp.databasin.org/datasets/9a09bb8652fa43beb4c7d4a7ebe92bcb> (accessed March 5, 2016).
- 19 Gap Status 1 and 2 are federal designations and specify lands that are permanently protected from conversion of natural land cover.
- 20 California Department of Food and Agriculture, “California Agricultural Statistics Review, 2014-2015,” 2015. Available at: <https://www.cdfa.ca.gov/Statistics/PDFs/2015Report.pdf> (accessed March 5, 2016); and United States Department of Agriculture – National Agricultural Statistics Service website, “2012 Census of Agriculture.” Available at: <http://www.agcensus.usda.gov/> (accessed March 5, 2016).
- 21 U.S. Department of the Interior – Bureau of Reclamation website, “Central Valley Project.” Available at: <http://www.usbr.gov/mp/cvp/> (accessed March 5, 2016); and California Department of Water Resources website, “California State Water Project Overview.” Available at: <http://www.water.ca.gov/swp/> (accessed March 5, 2016).
- 22 Department of Conservation website, “The Land Conservation Act.” Available at: <http://www.conservation.ca.gov/dlrp/lca> (accessed March 5, 2016).
- 23 California Department of Conservation Division of Land Resource Protection, “California Farmland Conversion Report,” September 2015. Available at: http://www.conservation.ca.gov/dlrp/fmmp/Documents/fmmp/pubs/2010-2012/FCR/FCR%202015_complete.pdf (accessed March 5, 2016).
- 24 Department of Conservation website, “Farmland Mapping and Monitoring Program”. Available at: <http://www.conservation.ca.gov/dlrp/fmmp> (accessed March 5, 2016).
- 25 Natural Resource Conservation Service, “Technical Guide Section II,” 2008. Available at: <http://efotg.sc.egov.usda.gov/references/public/ca/4a-sectioniicropinterp.pdf> (accessed March 5, 2016).

- 26 Natural Resource Conservation Service website, “Description of SSURGO Database.” Available at: http://www.nrcs.usda.gov/wps/portal/nrcs/detail/soils/survey/geo/?cid=nrcs142p2_053627 (accessed March 5, 2016).
- 27 University of California website, “California agriculture.” Available at: <http://californiaagriculture.ucanr.edu/landingpage.cfm?article=ca.v069n02p75&fulltext=yes> (accessed March 5, 2016).
- 28 U.S. Department of Agriculture, National Agricultural Statistics Service website, “CropScape – Cropland Data Layer.” Available at: <http://nassgeodata.gmu.edu/CropScape/> (accessed March 5, 2016).
- 29 Patrick A. Kelly, Scott E. Phillips, and Daniel F. Williams, “Documenting Ecological Change in Time and Space: The San Joaquin Valley of California,” 2005, pp. 57-78. Available at: <http://esrp.csustan.edu/publications/pubhtml.php?doc=mvz2003&file=mvzmss.html> (accessed March 5, 2016).
- 30 Daniel F. Williams et al, “Recovery Plan for Upland Species of the San Joaquin Valley, California,” 1998. Available at: <http://esrp.csustan.edu/publications/recoveryplan.php> (accessed March 5, 2016).
- 31 California Department of Fish and Wildlife, “State and Federally Listed Endangered and Threatened Animals of California,” April 2016. Available at: <https://nrm.dfg.ca.gov/FileHandler.ashx?DocumentID=109405&inline=1> (accessed March 5, 2016).
- 32 Stillwater Sciences, “Merced River Corridor Restoration Plan,” 2002. Available at <http://www.stillwatersci.com/resources/2004mercestrestoplan.pdf> (accessed March 5, 2016); San Joaquin River Restoration Program website. Available at: <http://www.restoresjr.net/> (accessed March 5, 2016); U.S. Department of the Interior – Bureau of Reclamation website, “Central Valley Project Improvement Act (CVPIA).” Available at <http://www.usbr.gov/mp/cvpia/> (accessed March 5, 2016); California Rangeland Conservation Coalition website. Available at: <http://carangeland.org/> (accessed March 5, 2016).
- 33 Norman Myers et al., “Biodiversity hotspots for conservation priorities,” *Nature*, Vol: 403, 2000, pp. 853-858.
- 34 H. Scott Butterfield et al., “Western San Joaquin Valley least conflict solar assessment. Unpublished report,” 2013. Available at http://scienceforconservation.org/dl/WSJV_SolarAssessment_2013.pdf (accessed March 5, 2016); Data Basin website, “Western San Joaquin Valley Solar Assessment.” Available at: <http://sjvp.databasin.org/datasets/a2a14a2f99ea4869a19c93a73cf42032> (accessed March 9, 2016); Dustin Pearce, Sam Young, Graham Wesolowski, Jane Cowan, and Andrew Gwin, “San Joaquin Valley Landscape-Scale Planning for Solar Energy and Conservation, Unpublished Master’s Thesis,” 2015. Available at: <http://sjvp.databasin.org/galleries/2e0a678476284fe788e5d2168991f288> (accessed March 5, 2016).
- 35 California Department of Fish and Wildlife website, “Areas of Conservation Emphasis (ACE-II).” Available at: <http://www.dfg.ca.gov/biogeodata/ace/> (accessed March 5, 2016).
- 36 California Department of Fish and Wildlife, “Areas of Conservation Emphasis (ACE-II) Project Report,” 2010, p. 19. Available at: <https://nrm.dfg.ca.gov/FileHandler.ashx?DocumentID=24369&inline=1> (accessed March 5, 2016).
- 37 Data Basin website, “California Wetlands.” Available at: <http://sjvp.databasin.org/datasets/3179034e3d414ad1a2b2e2932c8ca573> (accessed March 5, 2016).
- 38 Data Basin website, “California Central Valley Wetlands and Riparian (5 Classes).” Available at: <http://sjvp.databasin.org/datasets/6ef327ceef1d4463858d66c0e3f4bdf4> (accessed March 5, 2016).
- 39 Carol W. Witham, Robert F. Holland, and John E. Vollmar, “Changes in the Distribution of Great Valley Vernal Pool Habitats from 2005 to 2012,” 2014, 39 pages. Available at: http://vernalpools.org/2012CVPIA/20141914_Final_2012_Remapping_Report.pdf (accessed March 5, 2016).
- 40 Data Basin website, “San Joaquin Least Conflict Solar Environmental Conservation Model Results and Inputs.” Available at: <http://sjvp.databasin.org/galleries/0749343c8a624455a07c277fd6344c50#expand=95143%2C95156%2C95159> (accessed March 5, 2016).
- 41 Data Basin website, “SJV Theobald 2013.” Available at: <http://sjvp.databasin.org/datasets/80553ff7836547149ce08680015cc08f> (accessed March 5, 2016).
- 42 Data Basin website, “San Joaquin Least Conflict Solar Environmental Conservation Model Results and Inputs.” Available at: <http://sjvp.databasin.org/galleries/0749343c8a624455a07c277fd6344c50#expand=95143%2C95156%2C95160> (accessed March 5, 2016).
- 43 Data Basin website, “San Joaquin Least Conflict Solar Environmental Conservation Model Results and Inputs.” Available at: <http://sjvp.databasin.org/galleries/0749343c8a624455a07c277fd6344c50#expand=95143%2C95156%2C95161> (accessed March 5, 2016).
- 44 To see a more detailed explanation of EEMS modeling system with examples on Data Basin, visit: <https://databasin.org/articles/e48fb1ac5ffe4454a324dff834de2ede> (accessed April 20, 2016).
- 45 D. Richard Cameron, Jaymee Marty, Robert F. Holland, “Whither the Rangeland?: Protection and Conversion in California’s Rangeland Ecosystems,” *PLoS ONE* 9(8), 2014. Available at: <http://dx.doi.org/10.1371/journal.pone.0103468> (accessed March 5, 2016).
- 46 Kristin B. Byrd et al., “Integrated climate and land use change scenarios for California rangeland ecosystem services: wildlife habitat, soil carbon, and water supply,” *Landscape Ecology* 30:4, 2015. Available at: <http://link.springer.com/article/10.1007/s10980-015-0159-7/fulltext.html> (accessed March 5, 2016).
- 47 Cal Fire website, “FRAP Mapping – FRAP GIS Data.” Available at: http://frap.fire.ca.gov/data/frapgisdata-sw-fveg_download (accessed March 5, 2016).
- 48 Joel R. Brown, Robert R. Blank, Guy R. McPherson, and Kenneth W. Tate, “An Issue Paper Created By the Society for Range Management,” 12 pages. Available at: http://www.rangelands.org/pdf/Global_Issue_Paper.pdf (accessed March 5, 2016).
- 49 For example, Senate Bill 18 (Ch. 905, Statutes of 2004) tribal consultations apply to local governments (California Cities and Counties) that are amending general plans, open space designations, or specific area plans. Senate Bill 18 would only apply as a result of the San Joaquin

Valley Least-Conflict planning effort should a local government choose to amend its general plan to specifically accommodate renewable energy development. Recent Assembly Bill 52 (Ch. 532, Statutes of 2014) amendments to the California Environmental Quality Act (CEQA) also require all CEQA lead agencies to conduct specific tribal consultation when properly requested by a California Native American Tribe. CEQA Assembly Bill 52 tribal consultations do not apply to the San Joaquin Valley Least-Conflict planning effort because there is no CEQA project before any lead agency.

- 50 Jeffrey S. Rosenthal, Gregory G. White, and Mark Q. Sutton, “Chapter 10. The Central Valley: A View from the Catbird’s Seat,” 2007, pp. 147-163. In: Terry L. Jones and Kathryn A. Klar (eds.), “California Prehistory: Colonization, Culture and Complexity,” AltaMira Press, 2010.
- 51 Michael Silverstein, “Yokuts: Introduction,” 1978, pp. 446-447. In: Robert F. Heizer (ed.), “Handbook of North American Indians, Vol. 8: California,” Washington D.C.: Smithsonian Institution, 1978.
- 52 W.J. Wallace, “Northern Valley Yokuts,” 1978, pp. 462-470. In: Robert F. Heizer (ed.), “Handbook of North American Indians, Vol. 8: California,” Washington D.C.: Smithsonian Institution, 1978.
- 53 Id.
- 54 R.F.G. Spier, “Foothill Yokuts,” 1978, pp.471-484. In: Robert F. Heizer (ed.), “Handbook of North American Indians, Vol. 8: California,” Washington D.C.: Smithsonian Institution, 1978.
- 55 Alfred Louis Kroeber (author), “Handbook of the Indians of California, 1976 reprinted edition,” New York: Dover Publications, originally published in 1925, 1120 pages.
- 56 Randall Milliken (author), “A Time of Little Choice: The Disintegration of Tribal Culture in the San Francisco Bay Area, 1769-1810,” Menlo Park, CA: Ballena Press, 1995, 364 pages.
- 57 Robert F. Heizer (ed.), “Handbook of North American Indians, Vol. 8: California,” Washington D.C.: Smithsonian Institution, 1978; M.L. Zigmund, “Kawaiisu,” 1986, pp. 398–411. In: Warren L. d’Azevedo (ed.), “Handbook of North American Indians, Vol. 11: Great Basin,” Washington D.C.: Smithsonian Institution, 1986.
- 58 These four tribes primarily consist of Foothill and Southern Valley Yokut Indians.
- 59 California ISO website, “Transmission planning for a reliable, economic and open grid.” Available at: <http://www.caiso.com/planning/Pages/TransmissionPlanning/Default.aspx> (accessed March 5, 2016).
- 60 California ISO website, “2015-2016 Transmission planning process.” Available at: <http://www.caiso.com/planning/Pages/TransmissionPlanning/2015-2016TransmissionPlanningProcess.aspx> (accessed March 5, 2016).
- 61 California ISO website, “Transmission planning for a reliable, economic and open grid.” Available at: <http://www.caiso.com/planning/Pages/TransmissionPlanning/Default.aspx> (accessed March 5, 2016).
- 62 California ISO website, “A streamlined process for interconnecting generating facilities.” Available at: <http://www.caiso.com/planning/Pages/GeneratorInterconnection/Default.aspx> (accessed March 5, 2016).
- 63 California Energy Commission website, “Renewable Energy Transmission Initiative (RETI) 2.0.” Available at: <http://www.energy.ca.gov/reti/> (accessed March 5, 2016).
- 64 California Energy Commission, “Renewable Energy Transmission Initiative 2.0 – Introduction Presentation,” 2016. Available at: http://docketpublic.energy.ca.gov/PublicDocuments/15-RETI-02/TN208287_20160121T121353_Introduction.pdf (accessed March 5, 2016).
- 65 California Energy Commission, “2015 Integrated Energy Policy Report,” 2015. Available at: http://docketpublic.energy.ca.gov/PublicDocuments/15-IEPR-01/TN210526_20160224T115020_2015_Integrated_Energy_Policy_Report_Full_File_Size.pdf (accessed March 5, 2016).
- 66 The Planning Center|DC&E, “San Joaquin Valley Demographic Forecasts – 2010 to 2050,” 2012. Available at http://www.valleyblueprint.org/files/San%20Joaquin%20Valley%20Demographic%20Forecasts%20-%20Final%2027%20Mar%202012_0.pdf. (accessed March 5, 2016).
- 67 Examples of right sizing include, but are not limited to, planning/building transmission lines with higher capacity ratings than the identified need, building double circuit transmission lines and only stringing one circuit initially, or building transmission infrastructure to a higher voltage level but only energizing at the voltage required to satisfy the identified need so as to be able to increase the capacity to satisfy expected longer-term needs with minimal environmental impact in the future.
- 68 Pamela Jacklin, Marcus Wood, and Jason Johns, □The Way Forward: Why Transmission Right Sizing and Federal Bridge Financing Hold the Key to Western Renewable Resource Development,□ 2010. Available at http://www.stoel.com/files/Transmission_Right-Sizing_Endnotes.pdf (accessed March 5, 2016).
- 69 California Energy Commission, “2015 Draft Integrated Energy Policy Report,” 2015, p. 118. Available at: http://docketpublic.energy.ca.gov/PublicDocuments/15-IEPR-01/TN206330_20151012T134153_2015_Draft_Integrated_Energy_Policy_Report.pdf (accessed March 5, 2016).
- 70 Nilgun Atamturk and Marzia Zafar, “Trends in Utility Infrastructure Financing,” August 2012. Available at <http://www.cpuc.ca.gov/WorkArea/DownloadAsset.aspx?id=3246> (accessed March 5, 2016).
- 71 National Renewable Energy Laboratory, “Impacts of Variability and Uncertainty in Solar Photovoltaic Generation at Multiple Timescales,” 2013, 41 pages. Available at: <http://www.nrel.gov/docs/fy13osti/58274.pdf> (accessed March 5, 2016).
- 72 Amy Wilson Morris and Jessica Owley, “Mitigating the Impacts of the Renewable Energy Gold Rush,” *Minnesota Journal of Law, Science & Technology* 15:1, 2014, pp. 293-388.
- 73 Michael Patrick Durkee, David H. Blackwell, and Thomas P. Tunny , “A Modern Perspective on the Williamson Act: Conservation, Confusion, and Controversy.” Available at <http://landusenavigators.com/articles/a-modern-perspective-on-the-williamson-act-conservation-confusion-and-controversy> (accessed March 5, 2016).



**For more information, please contact Ethan Elkind
at eelkind@law.berkeley.edu.**

**www.clee.berkeley.edu
[@berkeleylawCLEE](https://twitter.com/berkeleylawCLEE)**

To view a complete set of the maps and data used in this report, visit

Data Basin San Joaquin Valley Gateway

www.sjvp.databasin.org