

## **UC Merced**

### **Proceedings of the Annual Meeting of the Cognitive Science Society**

#### **Title**

Mutual Adaptive Meaning Acquisition by Paralanguage Information: Experimental Analysis of Communication Establishing Process

#### **Permalink**

<https://escholarship.org/uc/item/53p3m4t7>

#### **Journal**

Proceedings of the Annual Meeting of the Cognitive Science Society, 24(24)

#### **ISSN**

1069-7977

#### **Authors**

Komatsu, Takanori  
Suzuki, Kentaro  
Ueda, Kazuhiro  
et al.

#### **Publication Date**

2002

Peer reviewed

# Mutual Adaptive Meaning Acquisition by Paralanguage Information: Experimental Analysis of Communication Establishing Process

Takanori Komatsu (komatsu@cs.c.u-tokyo.ac.jp)

Kentaro Suzuki (suzuki@cs.c.u-tokyo.ac.jp)

Kazuhiro Ueda (ueda@gregorio.c.u-tokyo.ac.jp)

Kazuo Hiraki (khiraki@idea.c.u-tokyo.ac.jp)

Department of System Sciences, The University of Tokyo

3-8-1 Komaba, Meguro-ku, Tokyo, 153-8902 JAPAN

Natsuki Oka(oka@mrit.mei.co.jp)

Advanced Technology Research Laboratories, Matsushita Electric Industrial Co., Ltd.

3-4 Hikoridai, Seika, Souraku, Kyoto 619-0237 JAPAN

## Abstract

The effects of adjustments in teaching strategy and of paralanguage information in speech sound on the meaning acquisition process were determined by means of an experiment in which the game “Pong” was played by a team of two subjects. One subject (the teacher) coached the other one (the operator), instructing the operator in which direction to move the game paddle and when to hit the “ball.” However, the teacher’s speech was rendered linguistically incomprehensible. Three phenomena were observed. First, the use of a high-pitched voice by the teacher caused the operator to pay more attention to her/his actions. Second, meaning acquisition could be regarded as a reinforcement learning process based on a multi-reward system (i.e., one for successful game action and a different one from the teacher’s high-pitched voice for the wrong action). Third, the subjects adapted to each other; that is, they learned to respond more appropriately to each other’s behaviors (we call this **mutual adaptation**). These three phenomena are thought to play important roles in the acquisition of meaning from incomprehensible speech.

## Introduction

How do people who speak different languages learn to communicate? How do they acquire the meanings of each other’s speech? One way to interpret the meaning-acquisition process is to view it as statistical learning in which a certain speech sound is linked to the situation in which it was given. Several research groups have constructed general meaning-acquisition models based on this simple interpretation (for instance, Siskind, 1996). Testing of these models demonstrated that the word meanings can be acquired using statistical learning methodologies.

Some groups have investigated the teaching of word meanings to robot agents, which can move by themselves (Billard et al., 1998; Roy, 1999). For example, Kaplan (2000) showed that a four-legged robot could learn the names of a dozen objects shown in front of its “eyes” (camera) by the experimenter during its action experiences.

One study in particular demonstrated that an autonomous agent could learn not only the meanings of instruction words but also the meanings of evaluation instructions such as “good” and “bad”. Suzuki et al. (2002) developed a learning agent model that could learn the

meanings of words and evaluation instructions during its action experiences.

A large variety of learner models have thus been demonstrated. Siskind’s learner model was a computer that processed string inputs; Kaplan’s was a four-legged robot that could learn object names; and Suzuki’s was a computer agent that could move by itself in a virtual environment. In contrast, only one type of “teacher” has been demonstrated, one who gave instruction based on unchangeable rules. In real life, however, good teachers adjust their teaching strategy to fit the learner’s mode of learning. For example, a caregiver will speak to a preverbal infant using only simple words. Then, when the infant starts to speak, the caregiver will start to use more complex words and speak in different ways. So far, there have been no studies on how dynamically adjusting the teaching strategy affects the meaning acquisition process.

Investigating the process involved in acquiring meanings from speech sounds requires investigating the effects of not only phoneme information, which can be expressed using characters and text, but also of paralanguage information, such as prosody, speech speed and loudness, which cannot be expressed using characters and text. The effects of paralanguages information have been studied in various acoustic studies. For example, many studies have focused on the turn-taking mechanism (Pirrehumbert & Hirschberg, 1990) and emotional recognition (Hirose et al., 1997). However, so far, there have been none on the effect of paralanguage information on the meaning acquisition process.

We investigated the effects of adjustments in teaching strategy and of paralanguage information in speech sounds on the meaning acquisition process. We carried out a communication experiment, in which a team of two subjects played “Pong”. One subject (the teacher) coached the other one (the operator), instructing her/him in which direction to move the game paddle and when to hit the “ball.” However, the teacher’s speech was rendered linguistically incomprehensible. We observed how the listener acquired the meanings of the given instructions. For the paralanguage information, we focused on prosodic information, because data extraction should be easier and the possibility of the engineering realization is higher. The results provide a new point of view about meaning acquisition process and can be used to develop

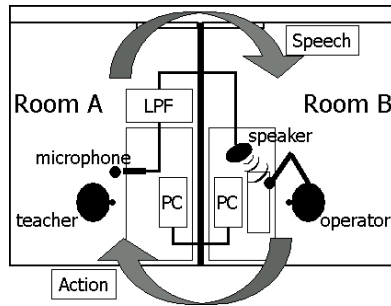

Figure 1: Game Environment

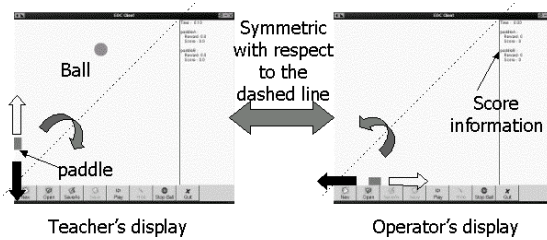

Figure 2: Different Display Settings

basic technologies for constructing interactive robots that can understand what is said to them, enabling them to communicate smoothly with people.

## Experiment

### Method

The experimental game environment is depicted in Figure 1. The two subjects were placed in separate rooms: the teacher in Room A, and the operator in Room B. The teacher's spoken instructions to the operator were transmitted through a low-pass-filter (LPF) and played over a speaker in Room B. The LPF masked the phoneme information, which included the symbolic elements of speech sound; it did not affect the prosodic elements. This means that the operator could hear only the prosodic information; s/he could not understand the teacher's instructions as meaningful linguistic information. They were simply noisy sound.

The team playing the game was awarded 10 points each time the operator hit the ball, and 10 points were deducted each time s/he missed it. As shown in Figure 2, the game display of the teacher differed from that of the operator: the teacher's display showed the ball, whereas the operator's did not. The operator could see only her/his paddle and the score information, indicating whether s/he had hit or missed the ball.

Even though the instructions were masked by the LPF, the operator still might be able to guess which instruction was given based on the number of phonemes heard. For example, "right" and "left" in Japanese

are *migi* and *hidari*, which have different numbers of phonemes. The display of the teacher and operator were thus made symmetrical with respect to the dashed line in Figure 2 to prevent biasing of the results.

### Subjects

Eleven teams, each composed of two subjects (Japanese, 20-28 years old, 18 men and 4 women), participated in the experiment. The members of each team were required to know each other. One additional team participated in two control experiments: one without LPF and one without instructions.

### Procedure

First, the experimenter explained to the subject team (one operator and one teacher) that the purpose of the experiment was to score as high a total score as possible by working together. Then, the experimenter let the team hear a vocal sample, with and without LPF masking, to demonstrate the filter's effects. The experimenter did not mention the differing displays.

The test was then started. Each team played two consecutive 10 minutes games, with 3 minutes of rest between them. The roles of teacher and operator were fixed, and the team members did not have an opportunity to talk face to face and share information.

## Results

To evaluate team performance, values were assigned to two types of actions, moving the paddle and hitting the ball. For each move action, if the operator moved the paddle in the teacher's intended direction, **Correct Direction Value (CDV)** was assigned one point; if s/he moved it in a different direction, CDV was assigned zero point. For each hit action, if the operator hit the ball, **Hit Value (HV)** was assigned one point; if s/he missed it, HV was assigned zero points. Testing statistical hypothesis using binominal distribution was used to group the subjects, and actually the teams were divided into three groups as follows.

**Group 1** Average CDV less than 0.8 point.

**Group 2** Average CDV more than 0.8 point; Average HV less than 0.7 point.

**Group 3** Average CDV more than 0.8 point; Average HV more than 0.7 point.

Table 1 shows the average values of the last ten hit and move actions for the three groups. Out of the 11 teams, two failed to understand any instructions (Group 1). Among the nine remaining teams, five succeeded in moving the paddle in the direction the teacher intended but could not hit the ball well (Group 2). We call this achievement "learning to recognize direction instructions." The four remaining teams could move to the teacher's intended position. We call this achievement "learning to recognize distance instructions"(Group 3).

Table 1: Correct Direction Value (CDV) and Hit Value (HV)

Group	(CDV, HV)
Group 1 (2 pairs)	(0.5, 0.5), (0.3, 0.2)
Group 2 (5 pairs)	(0.9, 0.3), (1.0, 0.2), (1.0, 0.5) (0.8, 0.6), (1.0, 0.6)
Group 3 (4 pairs)	(1.0, 0.9), (1.0, 0.7) (1.0, 0.7), (0.9, 0.8)
*control	no instructions (0.5, 0.2), (0.4, 0.3) without LPF (1.0, 0.7), (1.0, 0.8)

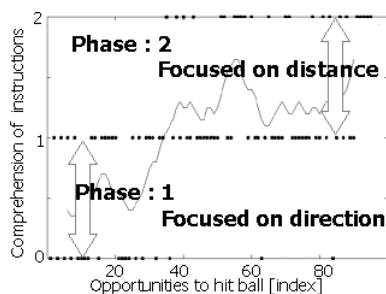

Figure 3: Trend in Comprehension of Instructions for Typical Group 3 Team

Table 1 shows that the values of two teams in Group 1 were the same as those for the control pair when they did not received instructions. Most of the teams in Group 2 and Group 3 had an average score between that of the two control settings, and some teams in Group 3 scored as high as the control group without the LPF.

We used **Comprehension of Instructions Value** to evaluate the operator’s comprehension of the instruction. This value was assigned 0 points if the paddle was moved in the wrong direction, 1 point if it was moved in correct direction but the ball was not hit, and 2 points if it was moved in the correct direction and the ball was hit. The value for a typical team in Group 3 are plotted in Figure 3. The curve shows the moving average of the ten hit opportunities. When the curve was between 0 and 1 point, the operator is thought to have focused on understanding the direction instructions; when it was between 1 and 2 points, the operator is thought to have focused on understanding the distance instructions. The operator more quickly learned to comprehend the direction instructions than the distance ones. We investigate the processes of these two learning phases in terms of the prosodic elements of the instructions, the movement of the paddle, and the variety of instructions given. We focused on the pitch of the teacher’s voice, which, among the prosodic elements, had the strongest relationship with the meaning of the instructions. As shown in Figure 6, when the pitch was increased, the operator tended to suddenly changed her/his action.

## Phase 1: Focused on Direction

The operator on nine of the 11 teams learned to comprehend the direction instructions. A particular teaching/learning process was used by most of the nine teams. First, the teacher gave a wide variety of instructions to the operator, e.g., “move to the center of the display”, “move a bit right”, etc. The pitch curve of this initial teaching is depicted on the left side of Figure 4. It would have been difficult for the operator to discriminate between the “*ue, ue, ue...* (up, up, up...)” instructions for the right direction and “*shita, shita...* (down, down...)” instructions for the left.

As the teaching continued, the teacher gradually decreased the variety of instructions, typically converging on only two, such as *ue* and *shita*. In contrast, the teachers on the unsuccessful teams did not decrease the variety and continued to use a wide variety (Figure 5). Decreasing the variety of instructions apparently makes it easier to understand direction instructions.

In conjunction with this gradual decrease in the variety of instructions, the difference in the pitch curves of these two instructions became more distinct. Most teachers started to repeat the instructions, e.g., “*ueueue...*” and “*shitashita...*” The former was audible as one long, continuous voice, while the latter sounded like many choppy utterances (see the right side of Figure 4).

Here, the operator learned to recognize the type of instructions according to the differed sounds. At the same time, subjects were ready to make her/his paddle actions correspond to them. The operator then started exploring this correspondence by trial and error. If the operator succeeded in hitting the ball, even by chance, s/he learned to associate the given instruction with her/his last action. The teacher elicited a correct response by using higher vocal tones (depicted in the circle in Figure 6). When the pitch at a certain point in a series of teaching voices was about 20 [Hz] higher than the pitch at the onset, and when this higher pitch continued for at least 500 [msec], the operators intuitively recognized this as a warning from the teacher. Specifically, when the operator heard instructions delivered at a higher pitch, s/he recognized that her/his current action was wrong and modified it accordingly. Therefore, high-pitched vocalizations in Phase 1 served as a negative reinforcement of the operator’s last action. The operators thus learned to compre-

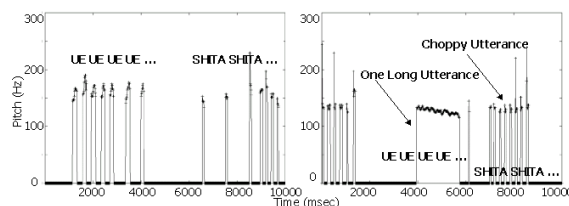

Figure 4: Pitch Curves of “*Ue*” and “*Shita*” in Phase 1. Left: 250 sec, Right: 540 sec



Figure 5: Variety of Instructions used by Successful/Unsuccessful Teams

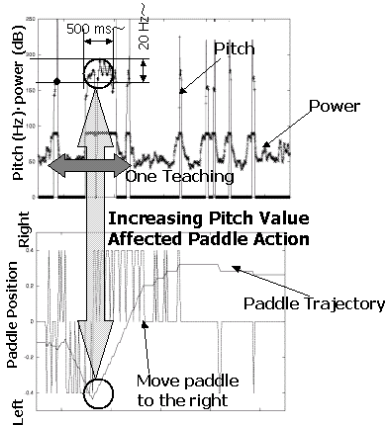

Figure 6: High-Pitch Element in Teaching Voice

hend the teacher’s instructions by reinforcement learning based on a positive reward (hitting the ball) and a negative one (hearing a high-pitched voice).

Learning to recognize the instructions during Phase 1 was due not only to the teacher’s efforts but also to the operator’s action. The actions of operators on the successful teams were initially reluctant, concentrated on inferring the teachers’ intentions from the given instructions. The operators started reacting actively after they inferred the intentions. Their actions thus indicated their comprehension of the given instructions. The operators on the unsuccessful teams were also reluctant at the beginning of the experiment, but over time they started moving actively, even though no instructions had been given: the operators seemed to disregard the instructions. In this case, the operator’s actions did not indicate any comprehension of the instructions.

Although at a first glance it seems that meaning acquisition was achieved only by the operator adapting to the teacher’s instructions, the teacher actually changed the instructions and method of delivery based on the operator’s comprehensions, which was judged from the operator’s reaction. The subjects actually learned to respond more appropriately to each other’s behavior, so that meaning acquisition was a mutual adaptation pro-

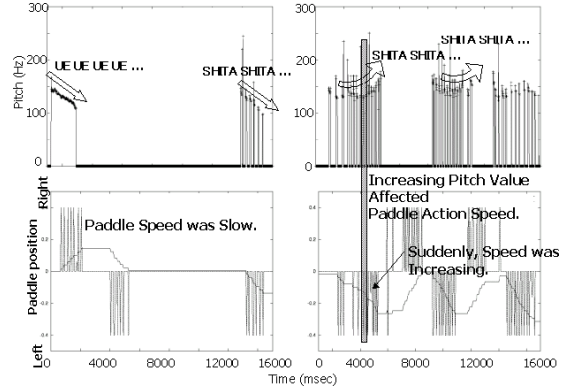

Figure 7: Pitch Curve of “Ue” and “Shita” in Phase 2. Left: 1070 sec, Right: 1270 sec

cess.

### Phase 2: Focused on Distance

In this “Pong” game experiment, learning to recognize the direction instruction was not sufficient for achieving a high score. The distance information was also needed to consistently hit the ball with the paddle. Of the nine teams that learned to recognize the distance instructions, four were able to recognize the distance instructions. These four teams exhibited two distinct approaches to learning to recognize distance instructions. One team used the “stop” instruction, and three teams did not.

**“Stop” Instruction Used** One team developed a common understanding of the “stop” instruction before developing one for direction instructions. The sound of “stop” has a short, skipping sound, so it was not difficult for the operator to understand this literally as “stop”. This team then developed a common understanding of direction instruction, like the repetitive “ueueue...” for move right and “shitashita...” for move left. In the case of using of “ue”, the teacher had to give repetitive instructions; otherwise the independent usage of “ue” was recognized as a choppy sound, meaning the opposite (left, “hidari”) direction. Therefore, the instruction to move right had to be repetitively elongated to avoid confusion with the usage of independent “ue”. Otherwise, the operator tended to go past the teacher’s intended position. When this “overrun” problem occurred, the teacher started saying “ueueue, stop, shitashita” to bring the operator back to the intended position. Finally, when the teacher said “stop” after a repetitive “ueueue...”, the operator immediately reversed direction so as not to overrun the teacher’s intended position. Thus, the operator took the “stop” instruction as the literal meaning or as meaning “go left”. This is a typical example of mutual adaptation in this experiment.

**“Stop” Instruction Not Used** The three teams that did not use the “stop” instruction learned to recognize direction instructions in a manner similar to that of the other team. In a typical case, after teaching the operator to learn to recognize direction instructions, the teacher pitched her/his voice higher at the onset of utterance and lower at the end, i.e., the intonation decreased, as shown on the left side of Figure 7. When the distance from the paddle appeared to the teacher to be too short, the teacher gradually increased the pitch at the end of the utterance. Specifically, the teacher increased the pitch at the end of the instructions utterance when a long distance appeared to be needed (see the right side of Figure 7), whereas s/he reduced it when the distance appeared to be short. In this way, the teacher controlled the operator’s action by increasing or decreasing the pitch at the end of the instruction utterance. High-pitched utterances spurred the operator’s actions, which can be broadly interpreted as drawing the operator’s attention to her/his actions.

Even among the nine teams who learned to recognize the direction instructions, five were unable to learn to recognize the distance instructions. The teachers on the successful teams came to realize that repetitive instructions were important to learning to recognize the direction instructions. They did this by observing the operators’ actions. The teachers on the unsuccessful teams apparently did not come to this realization and were thus perplexed when the operators headed in the opposite direction when an “*ue*” instruction was given.

Comparison of the successful teams with the unsuccessful ones in the two meaning acquisition phases showed that the team members had to learn to respond appropriately to one another’s behaviors to acquire a high score. The series of dynamic behaviors shown by the successful teams can be regarded as **mutual adaptation**.

Three points in particular were observed for the successful teams.

1. The use of a high-pitched voice by the teacher caused the operator to immediately focus on her/his action.
2. The operator learned to recognize the teacher’s instructions by reinforcement learning composed of a positive reward (hitting the ball) and a negative one (hearing a high-pitched voice).
3. During the meaning acquisition process, mutual adaptation was observed. That is, team members learned to respond more appropriately to each other’s behaviors.

Thus, paralinguistic information functioned as a negative reward in the reinforcement learning process, and the teacher’s adjustment in teaching strategy was observed as a mutual adaptation process. Paralinguistic information and adjustment in teaching strategy thus play important roles in learning to recognize unknown teaching utterances.

## Discussion

### Effects of Adjusting Teaching Strategy

In this experiment, we observed a mutual adaptation process: the two members (the teacher and operator) learned to respond more appropriately to each other’s behaviors. This study did not, however, consider how substantial differences between dynamic and static teaching strategies affect the meaning acquisition process. The actual effects of the teacher’s dynamic instructions on meaning acquisition are thus unclear. We plan to investigate this effect by carrying out additional experiments in which we will control the behavior of the teachers. In any case, we observed that the teachers on the successful teams adjusted their teaching strategy according to the operator’s comprehension of the given instructions. This observed behavior differs from one-directional, or fragmented communication aspect, such as that in the code model of Shannon & Weaver (1949). Wiener et al. (1972) argued that a symbol exchange model, which is a code model, is a primitive model of communication. Sperber and Wilson (1986) refuted this argument and argued instead that their “relevance theory” is a primitive model of communication. Although this theory might approach the essence of human communications and thus overcome the bottleneck of the code model: inferences in this theory can only be made using simple “deductive” inference rules (Kimura, 1997). Therefore, this theory is equivalent to the code model if we regard the inference “rules” as a complicated “code”. This theory, moreover, has another problem: technical terms in the theory are not connected through physical existence. These unsolved problems reduce the theory’s ability to explain actual communications.

In our experiment, it seemed at first that only the operator adapted to the teacher’s behavior, because only the teacher could give spoken instructions. However, during the process of establishing communication, we observed that not only did the operator adapt to the teacher’s behavior, the teacher adapted to the operator’s behavior. While it is not uncommon for a teacher, who is usually an information transmitter, to sometimes become an information receiver, in our experiment, the transmitting and receiving occurred simultaneously. This observed phenomenon cannot be explained by the code model. Thus, the results of our experiment suggest that the actual communication process cannot be expressed using a one-directional communication view like the code model. Instead, a mutual adaptive view that cannot be decoded into one-directional relationships is needed.

### Effects of Paralinguistic Information

In this experiment, we observed that the use of a high-pitched voice by the teacher caught the operator’s attention. In general, the pitch of a speech sound decreases as the utterance draws to the end. If the pitch deviates from this pattern, the listener immediately catches the change. The observed function of the high-pitched voice in our experiment can be explained by this “prominence mech-

anism.” Each team, regardless whether it was successful or not, actually made use of this function, which might be a universal trait among humans.

An infants’ salient attention to a motherese voice, as revealed in various cognitive development studies, suggests that sensitivity to prosodic information is either an innate function or is learned just after birth. From our results, it might be said that infants react to the prosodic information in the caregiver’s speech, not to the phoneme information. The meaning acquisition process observed in our experiment can be regarded as reinforcement learning with multiple-rewards, and the high-pitched voice among the various types of prosodic information functioned as one of two rewards. That is, prosodic information affects the meaning acquisition process at some basic levels. Thus, it can be assumed that the infants’ language acquisition process and the meaning acquisition process in our experiment are similar in both depend on receiving prosodic information before acquiring the actual meanings of speech or teachings. Further research should reveal how this assumption is related to the language acquisition processes.

### Application Based on Results

From the results of our experiment, we conclude that paralinguistic information and adjustments in teaching strategy play important roles in learning the meaning of unknown utterance. If an autonomous robot had such abilities, it should be able to learn the meanings of human utterances and thus be able to communicate with people smoothly. In the traditional method of developing an interactive robot system, the designer needs to map specific utterance to the robot’s functions. However, by applying the phenomena observed in our experiment, the designer need not to define such a mapping *a priori*, but simply needs to define “high-pitched voice = negative reward” and “successful action = positive reward”. From these definitions, the robot can learn by itself the mapping between unknown utterances and its possible actions by using a reinforcement learning process based on the two types of rewards. Consequently, the robot will be able to adapt to its owner by trial and error, and over time the robot and owner can create an intimate relationship.

### Conclusions

A communication experiment was carried out to observe the effects of a teacher’s adjustment in teaching strategy and of paralinguistic information in terms of learning the meanings of unknown utterances. An adjustment in teaching strategy was observed as a mutual adaptation process, in which the two subjects on a team learned to respond more appropriately to each other’s behavior, and paralinguistic information was observed to function as a negative reward in a reinforcement learning process for meaning acquisition. These two phenomena thus play important roles in learning the meaning of unknown utterances.

### References

- Billard, A., Dautenhahn, K., & Hayes, G. (1998). Experiments on human-robot communication with robots, and interactive learning and communicating doll robot. In B. Edmonds and K. Dautenhahn (Eds.), *Socially situated intelligence workshop (SAB98)* (pp. 4–16).
- Hirose, K., Kawanami, H., & Ihara, N. (1997). Analysis of intonation in emotional speech. *Proceedings of ESCA tutorial and Research Workshop in Intonation: Theory, Models and Applications*.
- Kaplan, F. (2000). Talking AIBO: First Experimentation of verbal interactions with an autonomous four-legged robot. In A. Nijholt & D. Jokinen (Eds.), *Learning to behave: interacting agents CELE-TWENTE Workshop on Language Technology* (pp. 63–75).
- Kimura, D. (1997). Information, regularity and communications – comparison between Shannon and Bateson. In Tani, Y (Eds.), *Communication no shizen-shi (in Japanese)*, Tokyo: Shin-yosha.
- Pirrehumbert, J. B., & Hirschberg, J. (1990). The meaning of intonational contours in the interpretation of discourse. In P. R. Cohen, and M. E. Pollack (Eds.), *Intentions in Communication*, Cambridge, MA: MIT Press.
- Shannon, C. & Weaver, W. (1949). *The Mathematical Theory of Communication*. Urbana: University of Illinois Press.
- Siskind, J. (1996). A computational study of cross-situational techniques for learning word to meaning mapping. *Cognition*, 61, 39–91.
- Sperber, D. & Wilson, D. (1986). *Relevance: Communication and Cognition*. Oxford: Blackwell.
- Suzuki, K., Ueda, K., & Hiraki, K. (2002). A Computational Model of an Instruction Learner: How to learn Good or Bad through Actions. *Cognitive Studies(In Japanese)*, in press.
- Roy, D. (1999). *Learning from sights and sounds: A computational model*. Doctoral dissertation, MIT Media Laboratory.
- Wiener, M., Davoe, S., Rubinow, S., & Geller, J. (1972). Nonverbal behavior and nonverbal communication. *Psychological Review*, 79.