

# UC San Diego

## UC San Diego Previously Published Works

### Title

Uncertainty and Sensitivity Analysis of Damage Identification Results Obtained Using Finite Element Model Updating

### Permalink

<https://escholarship.org/uc/item/4w9530q2>

### Journal

Computer Aided Civil and Infrastructure Engineering, 24(5)

### Authors

Moaveni, Babak  
Conte, Joel P  
Hemez, François M

### Publication Date

2009-07-01

### DOI

10.1111/j.1467-8667.2008.00589.x

Peer reviewed

# **Uncertainty and Sensitivity Analysis of Damage Identification Results Obtained Using Finite Element Model Updating**

**Babak Moaveni & Joel P. Conte<sup>1</sup>**

*Department of Structural Engineering, University of California, San Diego*

**&**

**François M. Hemez**

*Los Alamos National Laboratory, New Mexico*

## **ABSTRACT**

A full-scale seven-story reinforced concrete shear wall building structure was tested on the UCSD-NEES shake table in the period October 2005 - January 2006. The shake table tests were designed so as to damage the building progressively through several historical seismic motions reproduced on the shake table. A sensitivity-based finite element (FE) model updating method was used to identify damage in the building. The estimation uncertainty in the damage identification results was observed to be significant, which motivated the authors to perform, through numerical simulation, an uncertainty analysis on a set of damage identification results. This study investigates systematically the performance of FE model updating for damage identification. The damaged structure is simulated numerically through a change in stiffness in selected regions of a FE model of the shear wall test structure. The uncertainty of the identified damage (location and extent) due to variability of five input factors is quantified through analysis-of-variance (ANOVA) and meta-modeling. These five input factors are: (1-3) level of uncertainty in the (identified) modal parameters of each of the first three longitudinal modes, (4) spatial density of measurements (number of sensors), and (5) mesh size in the FE model used in the FE model

---

<sup>1</sup> To whom correspondence should be addressed. E-mail: [jpconte@ucsd.edu](mailto:jpconte@ucsd.edu)

updating procedure (modeling error). A full factorial design of experiments is considered for these five input factors. In addition to ANOVA and meta-modeling, this study investigates the one-at-a-time sensitivity analysis of the identified damage to the level of uncertainty in the identified modal parameters of the first three longitudinal modes. The results of this investigation demonstrate that the level of confidence in the damage identification results obtained through FE model updating, is a function of not only the level of uncertainty in the identified modal parameters, but also choices made in the design of experiments (e.g., spatial density of measurements) and modeling errors (e.g., mesh size). Therefore, the experiments can be designed so that the more influential input factors (to the total uncertainty/variability of the damage identification results) are set at optimum levels so as to yield more accurate damage identification results.

## **1. Introduction**

In recent years, structural health monitoring has received increasing attention in the civil engineering research community with the objective to identify structural damage at the earliest possible stage and evaluate the remaining useful life (damage prognosis) of structures. Vibration-based, non-destructive damage identification is based on changes in dynamic characteristics (e.g., modal parameters) of a structure. Experimental modal analysis (EMA) has been used as a technology for identifying modal parameters of a structure based on its measured vibration data. It should be emphasized that the success of damage identification based on EMA depends strongly on the accuracy and completeness of the identified structural dynamic properties. Extensive literature reviews on vibration-based damage identification are provided by Doebling et al. (1996, 1998) and Sohn et al. (2003).

Damage identification consists of (1) detecting the occurrence of damage, (2) localizing the damage zones, and (3) estimating the extent of damage (Rytter, 1993). Numerous vibration-based methods have been proposed to achieve these goals. Salawu (1997) presented a review on the use of changes in natural frequencies for damage detection only. However, it is in general impossible to localize damage (i.e., obtain spatial information on the structural damage) from changes in natural frequencies only. Pandey et

al. (1991) introduced the concept of using curvature mode shapes for damage localization. In their study, by using a cantilever and a simply supported analytical beam model, they demonstrated the effectiveness of employing changes in curvature mode shapes as damage indicator for detecting and localizing damage. Other methods for damage localizations include strain-energy based methods (Shi et al., 2002) and the direct stiffness calculation method (Maeck and De Roeck, 1999). A class of sophisticated methods consists of applying sensitivity-based finite element (FE) model updating for damage identification (Friswell and Mottershead, 1995). These methods update the physical parameters of a FE model of the structure by minimizing an objective function expressing the discrepancy between numerically predicted and experimentally identified features that are sensitive to damage such as natural frequencies and mode shapes. Optimum solutions of the problem are reached through sensitivity-based optimization algorithms. Recently, sensitivity-based FE model updating techniques have been applied successfully for condition assessment of structures (Teughels and De Roeck, 2004).

A full-scale seven-story reinforced concrete (R/C) shear wall building slice was tested on the UCSD-NEES uni-axial shake table in the period October 2005 - January 2006. The shake table tests were designed so as to damage the building progressively through several historical seismic motions reproduced on the shake table. At various levels of damage, several dynamic tests of different lengths and amplitudes were performed to identify the modal parameters of the building which responded as a quasi-linear system with dynamic parameters depending on the level of structural damage. A sensitivity-based FE model updating approach was used to identify damage at each of several damage states of the building based on its identified modal parameters. The estimation uncertainty in both the system identification and damage identification results was observed to be significant (Moaveni et al., 2006, 2008a, 2008b; He et al., 2006). This motivated the authors to perform (through numerical simulation) an uncertainty analysis on these system and damage identification results. In an earlier study (Moaveni et al., 2007), the authors investigated the performance of three different output-only system identification methods, used for experimental modal analysis of the shear wall building, as a function of the uncertainty/variability in the

following input factors: (1) amplitude of input excitation, (2) spatial density of measurements, (3) measurement noise, and (4) length of response data used in the identification process. This paper, which is an extension of the above mentioned study, investigates the performance of damage identification using FE model updating based on the identified modal parameters of the first three longitudinal vibration modes. In order to perform a systematic and comprehensive uncertainty analysis of damage identification results, information about exact damage location and extent, and exact modal parameters are required which are not available from the experimental data. Therefore, in this study the identified modal parameters of the damaged structure are generated numerically using a three-dimensional FE model of the test structure with different levels of damage simulated (numerically) along the height of the structure. The uncertainty of the identified damage (location and extent) is quantified through analysis-of-variance (ANOVA) and meta-modeling due to variability of the following input factors: (1-3) level of uncertainty in the (identified) modal parameters of the first three longitudinal modes (M1, M2, M3), (4) spatial density of measurements (number of sensors) (S), and (5) mesh size in the FE model used for damage identification (modeling error) (E). A full factorial design of experiments is considered for these five input factors. In addition to ANOVA and meta-modeling for effect screening, this study investigates the sensitivity of the identified damage to the level of uncertainty in the identified modal parameters for the first three longitudinal modes. This global sensitivity analysis is performed through one-at-a-time (OAT) perturbation of individual input factors M1, M2 and M3.

## **2. Finite Element Model of the Test Structure**

The full-scale seven-story R/C building slice tested on the UCSD-NEES shake table consists of a main wall (web wall), a back wall perpendicular to the main wall (flange wall) for lateral stability, concrete slabs at each floor level, an auxiliary post-tensioned column to provide torsional stability, and four gravity columns to transfer the weight of the slabs to the shake table. Figure 1 shows a picture of the test structure, a drawing of its elevation, and a rendering of its FE model with fine mesh (one of the two FE models used in this study). Also, a plan view of the structure is presented in Figure 2. Details about

construction drawings, material test data, and other information on the set-up and conducting of the experiments are available in Panagiotou et al. (2007).

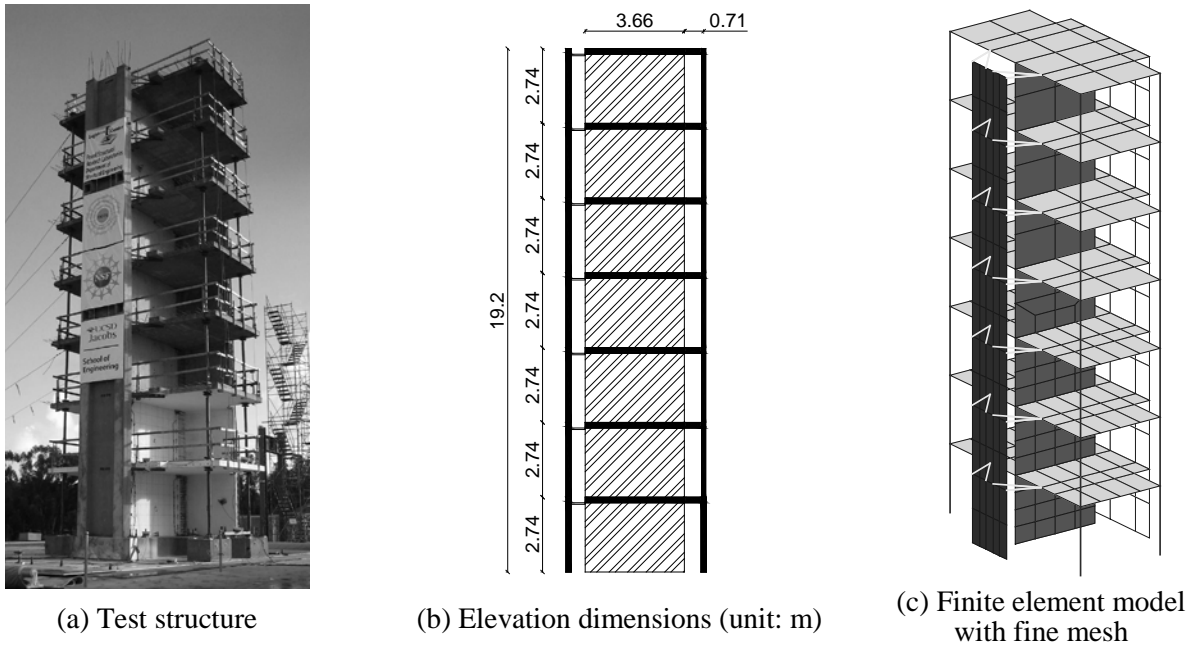

Figure 1. R/C shear wall building slice

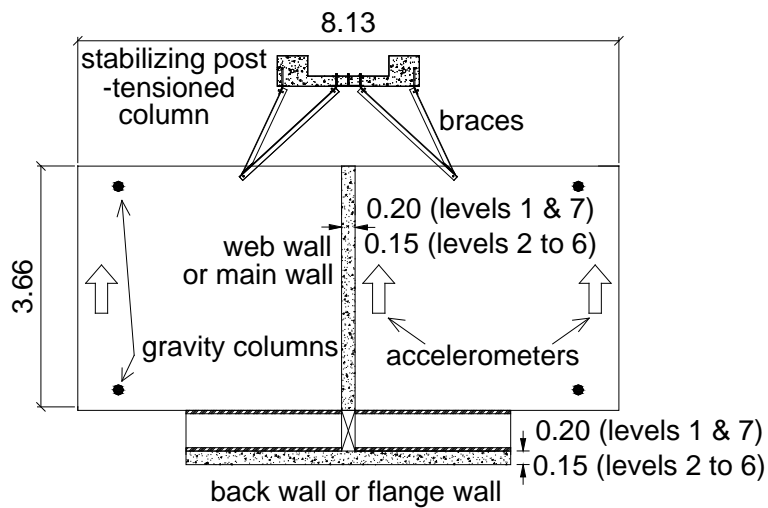

Figure 2. Plan view of the test structure (unit: m)

A three dimensional linear elastic FE model of the test structure was developed using a general-purpose FE structural analysis program, FEDEASLab (Filippou and Constantinides, 2004). A four-node linear flat shell element (with four Gauss integration points) borrowed from the FE literature was implemented in

FEDEASLab in order to model the web wall, back wall, and concrete slabs (He et al., 2006). In the FE model of the test building, the gravity columns and braces connecting the post-tensioned column to the building slabs are modeled using truss elements. The inertia properties of the test structure are discretized into lumped translational masses at each node of the FE model. In this study, two FE models of the building with different mesh sizes (i.e., numbers of elements) are used in the FE model updating process in order to investigate the effects of mesh size (modeling error) on the damage identification results. The FE model with fine mesh is also used for generating the modal parameters of the damaged structure with damage simulated as change in material stiffness (effective moduli of elasticity) distributed over the finite elements of the web wall. Table 1 reports the measured moduli of elasticity (through concrete cylinder tests) at various heights (stories) of the test structure, which are used in both FE models representing the test structure in its undamaged/baseline state.

Table 1. Measured moduli of elasticity at different heights of the test structure

Concrete Components	Measured Modulus of Elasticity (GPa)
1 <sup>st</sup> story	24.47
2 <sup>nd</sup> story	26.00
3 <sup>rd</sup> story	34.84
4 <sup>th</sup> story	30.20
5 <sup>th</sup> story	28.90
6 <sup>th</sup> story	32.14
7 <sup>th</sup> story	33.54

The natural frequencies and mode shapes of the first three longitudinal modes are used in the damage identification process. Figure 3 shows the modal parameters of the first three longitudinal modes computed from the fine mesh FE model representing the building in its undamaged state. These mode shapes and natural frequencies are in relatively good agreement with their counterparts identified experimentally based on ambient measurement data recorded on the undamaged test structure (Moaveni et al., 2006, 2008a).

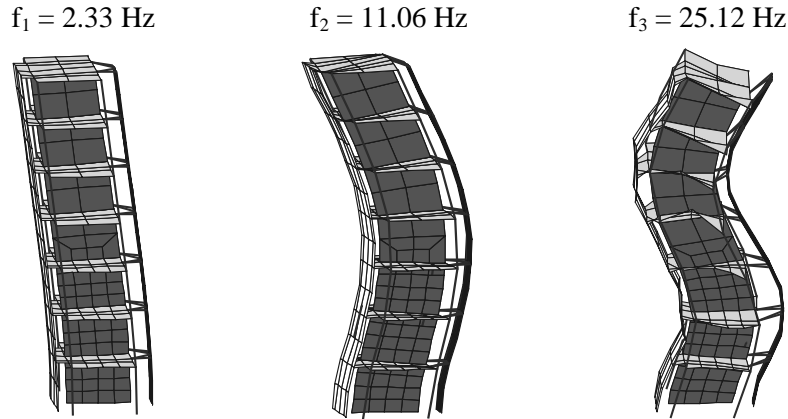

Figure 3. Mode shapes of first three longitudinal modes of fine mesh FE model representing undamaged structure

### 3. Description of Input Factors Studied and Design of Experiments

As already mentioned, the objective of this study is to analyze and quantify the uncertainty of the identified damage obtained using a FE model updating strategy due to the variability of five input factors: (1-3) level of uncertainty in the (identified) modal parameters of each of the first three longitudinal modes (M1, M2, M3), (4) spatial density of measurements (number of sensors) (S), and (5) mesh size in the FE model used for damage identification (a type of modeling error) (E). A number of other factors could be considered such as modeling assumptions (e.g., type of finite elements), number of updating parameters (number of sub-structures), type and number of residuals and their weights used in the objective function. This study is restricted to the above mentioned 5 factors in their considered ranges/levels which are selected based on previous experience and expert opinion (Moaveni et al., 2006, 2008a, 2008b; He et al., 2006). It should be noted that the enormous computational cost of the uncertainty analysis presented here prevented the authors from considering more input factors and also more than two levels for each input factor considered. This section briefly describes each of the input factors considered in this study and the design of experiments considered.

#### 3.1. Uncertainty in Modal Parameters

In practice, the main source of uncertainty in damage identification results arises from the uncertainty in the estimates of modal parameters that are used in the damage identification process. In a previous study



by the authors (Moaveni et al., 2007), it was observed that the estimation uncertainty of the modal parameters identified using three state-of-the-art output-only system identification methods (i.e., Natural Excitation Technique combined with Eigensystem Realization Algorithm, Data-driven Stochastic Subspace identification, and Enhanced Frequency Domain Decomposition) depend significantly on the variability of various input factors such as amplitude of excitation (i.e., level of nonlinearity in the response), level of measurement noise, and length of measured data used for system identification. In this study, the modal parameters of the first three longitudinal vibration modes are used in the damage identification process. Two levels of uncertainty, namely 0.5% and 1.0% coefficient-of-variation (COV) are considered for the natural frequencies and mode shape components of these three modes. These considered levels of uncertainty in modal parameters are selected based on previous experience with this test structure (Moaveni et al., 2006, 2008a). Environmental conditions can produce a much larger variability/uncertainty (up to 18% difference) in the identified modal parameters. However, in the presence of this level of uncertainty in the modal parameters, no damage identification algorithm will yield reasonable results. This is due to the fact that the changes in modal parameters due to damage are smaller than the variability of the identified modal parameters at a certain damage state due to changes in environmental conditions. Thus, in order to have converged and reasonable damage identification results in this study, the modal parameters are considered to be estimated with a reasonable level of accuracy. In practice, methods are needed to separate the changes in identified modal parameters (including their uncertainty) due to damage from those due to changes in environmental conditions. In this study, the modal parameter estimators are assumed to be unbiased (i.e., mean value of parameter estimates coincides with the “exact” parameter value). For each natural frequency and mode shape component of a vibration mode at a considered level of uncertainty, 20 noise realizations are generated from zero-mean Gaussian distributions with standard deviations scaled to result in the considered COV. The random estimation errors added to the natural frequencies and mode shape components are statistically independent (across the realizations and across natural frequencies and mode shape components). In general, the identified modal parameters of different vibration modes are statistically correlated. This statistical correlation

depends on many factors such as the characteristics of the input excitation (amplitude and frequency content), the closeness of the vibration modes of interest, and the mode shapes of the closely spaced modes. In the case when the vibration modes of interest are not closely-spaced, the cross-modal statistical correlation of modal parameters remains small. Therefore, for this reason and for simplicity, this study ignores the cross-modal statistical correlation of modal parameters. Statistics in terms of mean and standard deviation (over the 20 identification runs for each combination of input factors) of the identified damage extent at each location (i.e., substructure) are studied as a function of the variability/uncertainty of the input factors.

### *3.2. Spatial Density of the Sensors*

The spatial density of sensors can affect the damage identification results since the number of residuals in the objective function for FE model updating is directly related to the number of identified mode shape components (i.e., number of sensors). It should be noted that the spatial density of sensors also influences (weakly) the uncertainty of the identified mode shapes and modal frequencies (Moaveni et al. 2007). During the dynamic testing of the shear wall building, the web wall of the test structure was instrumented with 14 longitudinal accelerometers. The measured data were used later for modal identification of the test structure. To study the performance of FE model updating for damage identification as a function of the spatial density of the sensor array (i.e., number of sensors), two different subsets of the 14 sensor array are considered, namely (1) 10 accelerometers on the web wall at all floor levels (i.e., top of floor slabs) and at mid-height of the first three stories, and (2) 14 accelerometers on the web wall at all floor levels and at mid-height of each story.

### *3.3. Mesh Size of FE Model Used for Damage Identification*

The last input factor considered in this study is the modeling error due to the mesh size of the FE model (i.e., spatial discretization of the test structure) used for damage identification. This input factor is considered at two levels, i.e., two FE models of the building are used in the FE model updating process. Figure 4 shows the two FE models with considered course and fine mesh sizes, respectively. The first

model is defined by 340 nodes and 322 shell and truss elements. The web wall at each story is modeled using 4 shell elements and the floor slabs are discretized into 12 shell elements each. The second model, which has a more refined mesh, is defined by 423 nodes and 398 elements. In this model, the web wall at each of the first three stories is modeled using 16 shell elements, while the higher stories (5 to 7) are modeled using 4 shell elements each. The 4<sup>th</sup> story of the web wall is modeled using 8 shell elements. The floor slabs are modeled using 24 shell elements for each of the first three floors and 12 shell elements for each of the higher floors (4 to 7). The back wall, post-tensioned column, gravity columns and steel braces are modeled in the same way in both FE models.

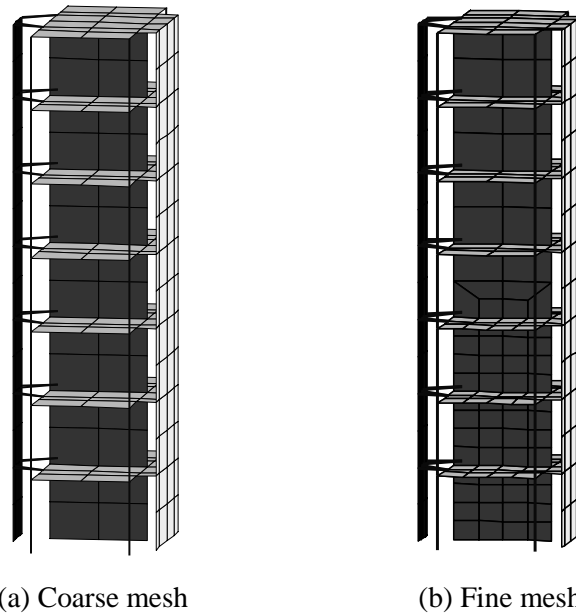

Figure 4. Two FE models with different discretization

It should be noted that these two FE models with different mesh size have different modal parameters (especially for the 3 modes considered in this study), even though the same material properties are used in the two models. The modal frequencies computed using the first model (coarse mesh) are

$$f_{\text{Coarse\_Mesh}} = [2.35 \quad 11.19 \quad 25.34] \text{ Hz} \quad (1)$$

which are slightly higher than their counterparts obtained using the second model (fine mesh) (see Figure 3). The “true” modal parameters of the damaged structure are computed using the second model (fine mesh) with damage represented as change of material stiffness (i.e., effective modulus of elasticity) distributed spatially and intensity-wise over the FE model according to the observed damage in the actual test structure (Moaveni et al., 2008b).

Table 2 summarizes the input factors and their levels considered in this study. A design of experiments (DOE) provides an organized approach for setting up experiments (physical or numerical). A full-factorial design of experiments is used in this study, where the five factors M1, M2, M3, S, and E (see Table 2) are varied in the design space. The full-factorial design requires a total of  $2 \times 2 \times 2 \times 2 \times 2 \times 20 = 640$  damage identification runs (a set of 20 identification runs for each combination of factors), but it offers the advantage of minimizing aliasing during the ANOVA (Saltelli et al. 2000). These 640 damage identification runs were performed using two fast server computers with dual-core Intel Xeon processors (3.0GHz) and also parallel computation on the “On Demand Cluster” of the San Diego Supercomputer Center (SDSC). Each of these identifications takes approximately an hour of CPU time on the fast server computers (for the fine mesh FE model).

Table 2. Description of factors studied and their levels considered

Factor	Description	Levels
M1	Uncertainty in modal parameters of mode 1	2 levels (0.5, 1% COV)
M2	Uncertainty in modal parameters of mode 2	2 levels (0.5, 1% COV)
M3	Uncertainty in modal parameters of mode 3	2 levels (0.5, 1% COV)
S	Spatial density of sensors	2 levels (10, 14 sensors)
E	FE mesh size	2 levels (322, 398 finite elements)

#### 4. Sensitivity Based Finite Element Model Updating for Damage Identification

In this study, a sensitivity-based FE model updating strategy (Friswell and Mottershead, 1995; Teughels and De Roeck, 2004) is used to identify (detect, localize and quantify) the numerically simulated damage

in the structure. The residuals in the objective function used for the FE model updating process are based on the natural frequency and mode shape estimates of each of the first three longitudinal modes of the test structure. It should be recalled that the modal parameter estimates are based on the exact modal parameters computed from the FE model of the damaged structure and then polluted with random noise added at the level of estimation uncertainty considered. As already mentioned, damage in the structure is introduced as changes (reduction) in material stiffness (effective modulus of elasticity) distributed over the finite element mesh of the web wall in the (fine mesh) FE model. This choice of damage model can be validated by the fact that both the damage identification results obtained from the test data (accelerometer data) and the observed damage (from high speed cameras, strain gages, LVDTs, and visual inspection) show that the structural damage is characterized by concrete cracks/degradation in the web wall, which can be reasonably modeled as a reduction in stiffness or effective modulus of elasticity of the material (Moaveni et al. 2008b). For the purpose of damage identification, the web wall is subdivided into ten sub-structures (each assumed to have a uniform value of the effective modulus of elasticity), 6 along the first three stories (every half story each) and 4 along the 4<sup>th</sup> to 7<sup>th</sup> stories (every story each), as shown in Figure 5. The level of damage simulated in these sub-structures is selected based on the profile of the observed/identified damage in the real test structure (Moaveni et al., 2008b) as

$$\mathbf{a}_{\text{exact}} = [45\% \quad 25\% \quad 66\% \quad 20\% \quad 10\% \quad 7\% \quad 4\% \quad 4\% \quad 2\% \quad 1\%]^T \quad (2)$$

from bottom to top of the web wall, where the damage factors  $\mathbf{a}_{\text{exact}}$  in percent represent the reduction in effective material modulus relative to the undamaged state. It should be noted that the identified damage in the real test structure was validated by the strain measurements and movies of the crack openings recorded by high speed cameras during the seismic tests. The bottom of the second story was observed to be the most damaged location in the building due to a lap-splice failure of the longitudinal steel reinforcement at this location. In order to identify damage in the structure, the effective moduli of elasticity of the sub-structures in the FE models are updated through minimization of an objective function. It should be noted that the sub-structures used in the updating process are the same as those used

in simulating the damaged structure, which makes it possible to identify the exact damage in the absence of estimation uncertainty in the modal parameters. The natural frequencies of the first three longitudinal modes computed using the fine mesh FE model of the structure with simulated damage given in Equation 2 are

$$f_{\text{Damaged\_Structure}} = [1.97 \quad 9.97 \quad 22.96] \text{ Hz} \quad (3)$$

Although it would be very interesting and beneficial to perform this type of uncertainty analysis for more than one damage pattern in the web wall, the findings reported here are limited to a single damage pattern due to the gigantic associated computational cost.

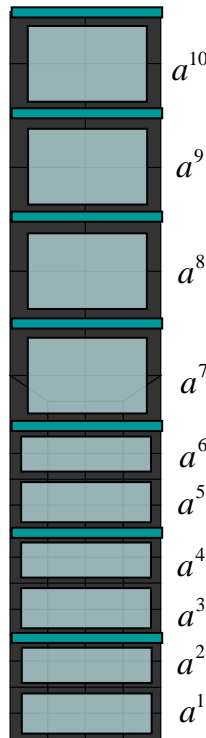

Figure 5. Sub-structures along the height of web wall

#### 4.1. Objective Function

The objective function used for damage identification is defined as

$$\min_{\theta} f(\theta) = \mathbf{r}(\theta)^T \mathbf{W} \mathbf{r}(\theta) = \sum_j [w_j r_j(\theta)]^2 \quad (4)$$

where  $\mathbf{r}(\boldsymbol{\theta})$  = residual vector containing the differences between FE computed and experimentally estimated modal parameters;  $\boldsymbol{\theta} \in \mathbb{R}^n$  = a set of physical parameters (effective moduli of elasticity), which must be adjusted in order to minimize the objective function;  $\mathbf{W}$  = a diagonal weighting matrix with each diagonal component inversely proportional to the square of the COV of the natural frequency of the corresponding vibration mode (Christodoulou and Papadimitriou, 2007). The main idea behind this selection is to assign the largest weight to the residuals corresponding to modal parameters identified with the least estimation uncertainty (i.e., identified the most accurately). It should be noted that the assigned weight for each mode shape component is equal to the weight assigned to the corresponding natural frequency divided by the number of mode shape components. Through this normalization, each modal frequency has globally the same weight as the corresponding set of mode shape components. A combination of residuals in natural frequencies and mode shape components is used to define the objective function as

$$\mathbf{r}(\boldsymbol{\theta}) = \left[ \mathbf{r}_f^T(\boldsymbol{\theta}) \quad \mathbf{r}_s^T(\boldsymbol{\theta}) \right]^T \quad (5)$$

in which  $\mathbf{r}_f(\boldsymbol{\theta})$ ,  $\mathbf{r}_s(\boldsymbol{\theta})$  = natural frequency and mode shape residual vectors, respectively. The two types of residuals are expressed, respectively, as

$$\mathbf{r}_f(\boldsymbol{\theta}) = \left[ \frac{\lambda_j(\boldsymbol{\theta}) - \tilde{\lambda}_j}{\tilde{\lambda}_j} \right], \quad j \in \{1 \quad 2 \quad \dots \quad N_m\} \quad (6a)$$

$$\mathbf{r}_s(\boldsymbol{\theta}) = \left[ \frac{\phi_j^l(\boldsymbol{\theta})}{\phi_j^r(\boldsymbol{\theta})} - \frac{\tilde{\phi}_j^l}{\tilde{\phi}_j^r} \right], \quad (l \neq r), \quad j \in \{1 \quad 2 \quad \dots \quad N_m\} \quad (6b)$$

where  $\lambda_j(\boldsymbol{\theta})$ ,  $\tilde{\lambda}_j$  = FE computed and experimentally identified eigenvalues (i.e.,  $\lambda_j = (2\pi \cdot f_j)^2$ ), respectively;  $\phi_j(\boldsymbol{\theta})$  and  $\tilde{\phi}_j$  = FE computed and experimentally identified mode shape vectors. In Equation 6b, the superscript  $r$  indicates a reference component of a mode shape vector (with respect to which the other components of the mode shape are normalized), the superscript  $l$  refers to the components that are

used in the updating process (i.e., at the sensor locations), and  $N_m$  denotes the number of vibration modes considered in the residual vector. In this study, the natural frequencies and mode shapes of the first three longitudinal modes (see Figure 3) of the structure are used to form the residual vector that has a total of 42 (when using 14 sensors) or 30 (when using 10 sensors) residual components consisting of 3 eigenfrequencies and  $3 \times (14 - 1) = 39$  or  $3 \times (10 - 1) = 27$  mode shape residuals, respectively.

#### 4.2. Damage Factors and Residual Sensitivities

In the process of FE model updating, the effective moduli of elasticity of the ten sub-structures are used as updating parameters. These ten sub-structures are distributed along the height of the web wall, with 6 of them along the first three stories (one per half story) and 4 from the 4<sup>th</sup> to the 7<sup>th</sup> story (one per story). Instead of the absolute value of each updating parameter, a dimensionless damage factor  $a^j$  is defined as

$$a^j = \frac{E_{undamaged}^j - E_{damaged}^j}{E_{undamaged}^j} \quad (7)$$

where  $E^j$  is the effective modulus of elasticity of the elements in sub-structure  $j$  ( $j = 1, 2, \dots, 10$ ). The damage factor  $a^j$  indicates directly the level of damage in substructure  $j$  (relative reduction in effective modulus of elasticity). The sensitivity of the residuals with respect to the damage factors  $a^j$  can be obtained through the modal parameter sensitivities as

$$\frac{\partial \mathbf{r}_f}{\partial a^j} = \left[ \frac{1}{\tilde{\lambda}_i} \frac{\partial \lambda_i}{\partial a^j} \right] \quad \text{and} \quad \frac{\partial \mathbf{r}_s}{\partial a^j} = \left[ \frac{1}{\phi_i^r} \frac{\partial \phi_i^l}{\partial a^j} - \frac{\phi_i^l}{(\phi_i^r)^2} \frac{\partial \phi_i^r}{\partial a^j} \right] \quad (8)$$

where the modal sensitivities  $\frac{\partial \lambda_i}{\partial a^j}$  and  $\frac{\partial \phi_i}{\partial a^j}$  are available in Fox and Kapoor (1968).

#### 4.3. Optimization Algorithm

The optimization algorithm used to minimize the objective function defined in Equation 3 is a standard Trust Region Newton method (Coleman and Li, 1996), which is a sensitivity-based iterative method available in the MATLAB optimization Toolbox (Mathworks Inc., 2005). The damage factors were



constrained to be in the range [0 0.90] for updating the undamaged FE model. The upper-bound of 90% was selected because no sub-structure of the building is expected to be damaged even close to 90% (largest simulated damage factor is 66%), while the lower bound of zero was selected considering that the identified effective moduli of elasticity cannot increase due to damage. The optimization process was performed using the “fmincon” function in Matlab, with Jacobian and first-order estimate of the Hessian matrices calculated analytically based on the sensitivities of the modal parameters to the updating variables, as given in Equation 8. It is important to mention that the proposed method was verified to be able to identify the exact simulated damage (given in Equation 2) in the absence of estimation uncertainty in the modal parameters used.

## **5. Uncertainty Quantification**

In this section, two methods are employed to quantify the uncertainty of the identified damage factor at each sub-structure due to variation of the five input factors considered. These two methods are: (1) effect screening which is achieved using analysis-of-variance (ANOVA) (Saltelli et al. 2000; Navidi 2007; Montgomery and Runger 2007; Walpole et al. 2006), and (2) meta-modeling (Wu and Hamada 2000; Myers and Montgomery 1995). Figure 6 shows the spread of the identified damage factors at the different sub-structures along the web wall height for all 640 damage identification runs. The horizontal solid line in each subplot indicates the value of the exact simulated damage for the corresponding substructure. The ensemble of identified damage factors is obtained by varying the five input factors M1, M2, M3, S and E, resulting in  $2 \times 2 \times 2 \times 2 \times 2 = 32$  combinations. For each combination of these five factors, 20 damage identification runs are performed based on modal parameters polluted with statistically independent realizations of the estimation errors, resulting in a total of  $32 \times 20 = 640$  identification runs.

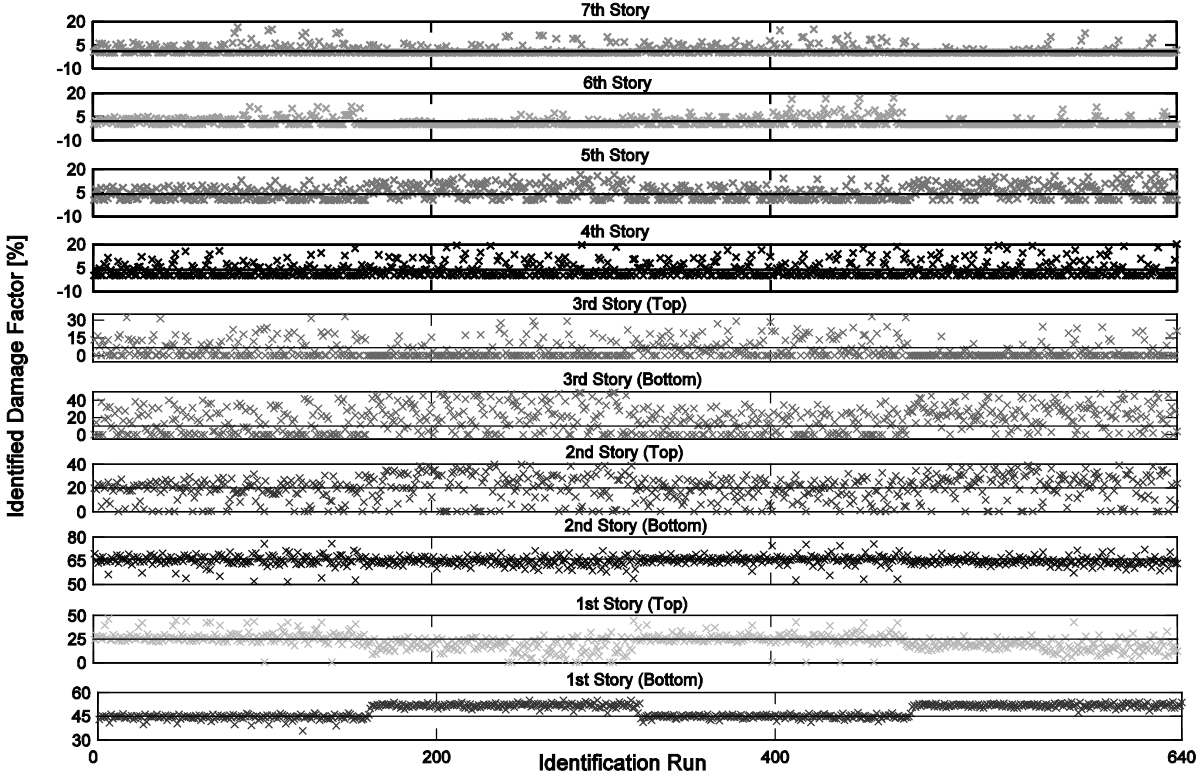

Figure 6. Spread of the identified damage factors at different sub-structures along the wall height (640 realizations)

Figure 7 shows in box plots the distributions of the identified damage factors together with their exact value (red solid line) at the different sub-structures. In such plots, the endpoints of the boxes are formed by lower and upper quartiles of the data, namely  $a_{0.25}^j$  and  $a_{0.75}^j$ . The vertical line within the box represents the median  $a_{0.5}^j$ , and the mean is displayed by the large dot. The bar on the right of the box extends to the minimum of  $a_{0.75}^j + 1.5 \times (a_{0.75}^j - a_{0.25}^j)$  and  $a_{\max}^j$ . In a similar manner, the bar on the left of the box extends to the maximum of  $a_{0.25}^j - 1.5 \times (a_{0.75}^j - a_{0.25}^j)$  and  $a_{\min}^j$ . The observations falling outside of these bars are shown with crosses. Table 3 reports the mean and standard deviation of the 640 sets of identified damage factors at the different sub-structures. The large bias and standard deviation in the identified damage factors in some sub-structures are due to the fact that the residuals used in the objective function are less sensitive to the updating parameters representing in these sub-structures. The uncertainty quantification is performed on the mean and standard deviation of the identified damage factors (over the

sets of 20 damage identification runs each). This analysis can be viewed as a crude variance reduction technique that reduces the variability of the output features (identified damage factors) arising from the 20 seed numbers corresponding to the 20 realizations of the random modal estimation errors.

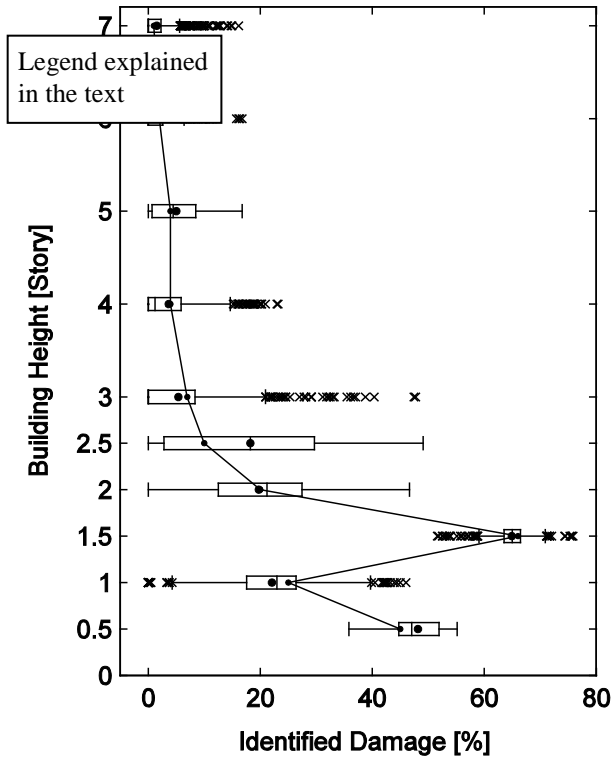

Figure 7. Distributions of identified damage factors in box plots together with their exact values

Table 3. Mean and standard deviation (STD) of identified damage factors at different sub-structures

Sub-Structure Location	Exact [%]	Mean [%]	STD
7th story	1	1.6	2.8
6th story	2	1.6	2.6
5th story	4	5.0	4.4
4th story	4	3.7	4.9
3rd story (top)	7	5.4	8.3
3rd story (bottom)	10	18.3	14.5
2nd story (top)	20	19.7	10.9
2 <sup>nd</sup> story (bottom)	66	64.9	3.1
1st story (top)	25	22.1	7.9
1st story (bottom)	45	48.2	3.9

Figures 8 and 9 show the spread of the mean and standard deviation of the identified damage factors, respectively, at the different sub-structures for all 32 combinations of the input factors. From Figures 8 and 9, it is not possible to quantify the contribution of each input factor or combination of input factors to the total uncertainty of the mean or standard deviation of the identified damage factors. Therefore ANOVA and meta-modeling are used for the uncertainty quantification of the mean and standard deviation.

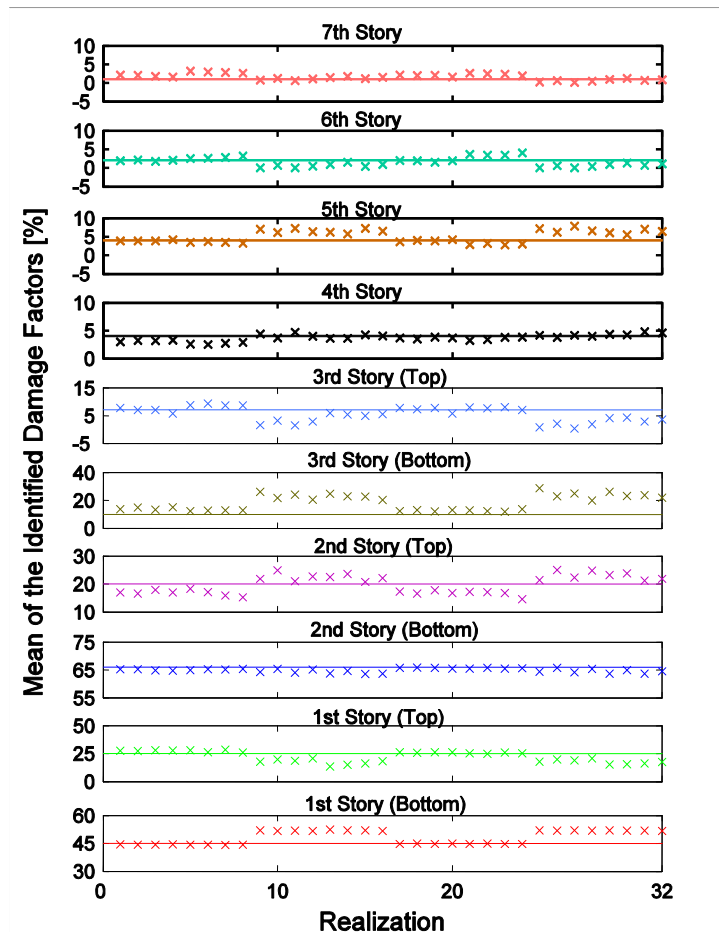

Figure 8. Spread of the mean of identified damage factors at different sub-structures (32 combinations of input factors)

### 5.1. Analysis-of-Variance (ANOVA)

To investigate the source of the observed uncertainty of the mean and standard deviation of identified damage factors shown in Figures 8 and 9, ANOVA is performed and the results are presented and discussed in this section. The theoretical foundation of ANOVA is that the total variance of the output

features can be decomposed into a sum of partial variances, each representing the effect of varying an individual factor independently from the others. These partial variances are estimated by the so-called R-square values. The input factor with the largest R-square value for an output feature has the most contribution to the uncertainty of that output feature. In this study, ANOVA is applied to 32 data sets of output features (i.e., mean and standard deviation of the identified damage factors over the set of 20 identification runs with independent realizations of the modal estimation errors, see Figures 8 and 9).

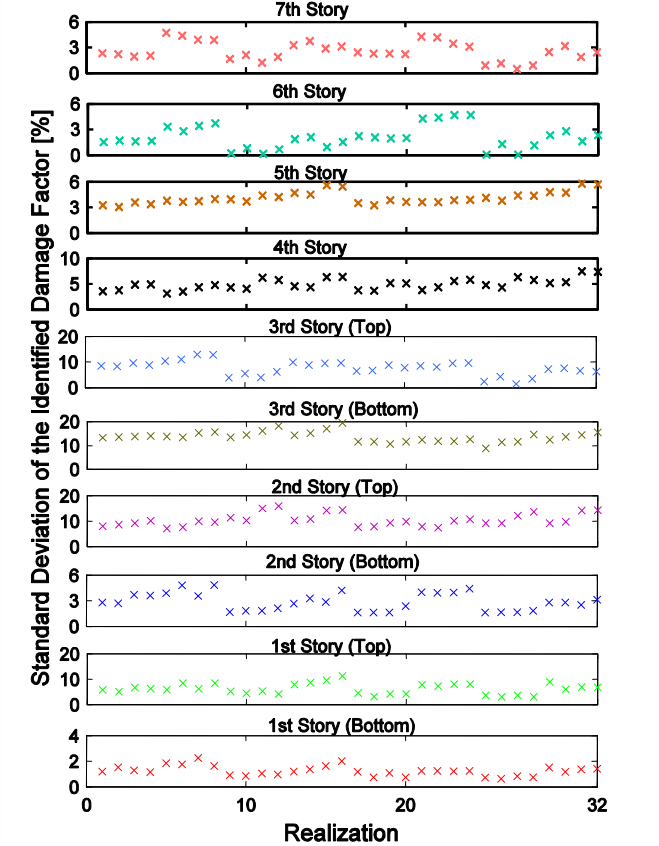

Figure 9. Spread of the standard deviation of identified damage factors at different sub-structures (32 combinations of input factors)

Figure 10 shows the R-square values of the mean and standard deviation of the identified damage factors for the 10 sub-structures considered. These R-square values are scaled such that their sum over all factors equates 100%.

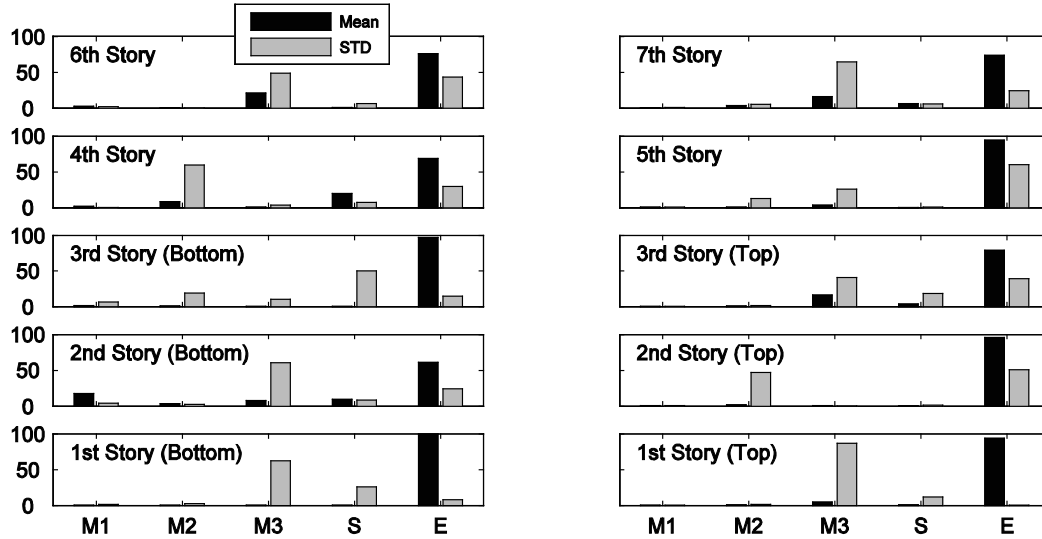

Figure 10. R-square of the mean and standard deviation (STD) of identified damage factors at different sub-structures due to variability of factors M1, M2, M3, S, and E

From Figure 10, the following observations can be made. (1) Mesh size (E) is the most significant input factor in introducing uncertainty in the mean value (i.e., estimation bias) of the identified damage. (2) Variability in the spatial density of the sensors (S) produces the least amount of uncertainty in the mean value of the identified damage factors at the different locations. This can be due to the fact that the considered levels for the spatial density of sensors (10 and 14) are already dense enough for the 10 updating parameters considered. Obviously, if different levels of S were considered with missing sensors at considered sub-structures, then this input factor would have more significant influence in the uncertainty of the identified damage in those sub-structures. It is also worth noting that this input factor has more relative contribution on the standard deviation of the identified damage. (3) In general, the level of uncertainty in the modal parameters (as measured by COV of estimated modal parameters) of the second and third longitudinal modes (M2 and M3) introduces more uncertainty on both mean and standard deviation of the identified damage than the uncertainty in the modal parameters of the first longitudinal mode (M1). This can be due to the fact that mode shape curvatures are well known to be one of the most sensitive features to local damage and higher modes have higher curvatures. This observation can be used in practice by designing dynamic experiments producing sufficient participation of higher

modes and therefore reducing their estimation uncertainty and leading to more accurate damage identification results. In practice, “designing” input excitations with relatively strong amplitude in the frequency range of the higher modes of interest will increase their relative contributions to the total response. (4) Mesh size (E) also introduces considerable amount of uncertainty to the standard deviation of the identified damage. However, this factor contributes less to the total uncertainty of the standard deviations than to that of the mean values of the identified damage.

## 5.2. Meta Modeling

Meta-models (also known as surrogate models) represent the relationship between input factors and output features without including any physical characteristics of the system (i.e., black-box models) (Wu and Hamada 2000; Myers and Montgomery 1995). The advantage of surrogate models is that they can be analyzed at a fraction of the cost it would take to perform the physics-based simulations. Meta-models must be trained, which refers to the identification of their unknown functional forms and coefficients. Their quality can be evaluated independently of the training step. The use of meta-models allows to further validate the effect screening results obtained from ANOVA. In this section, a linear polynomial model is fitted to the identified damage factors by including all input factors considered here and is expressed as

$$Y^j = \beta_0^j + \beta_{M1}^j M1 + \beta_{M2}^j M2 + \beta_{M3}^j M3 + \beta_S^j S + \beta_E^j E , \quad j = 1, 2, \dots, 10 \quad (9)$$

where  $Y^j$  denotes the  $j^{\text{th}}$  output feature (i.e., mean identified damage factor at  $j^{\text{th}}$  sub-structure), and  $\beta^j$ 's are the meta-model coefficients to be determined. In the above equation: (1) the input factors are scaled between -1 (corresponding to the low value) and +1 (corresponding to the high value); (2) the identified damage factors are normalized by their corresponding exact values so that the estimated  $\beta^j$  coefficients all have dimensionless units and the same order of magnitude for different output features (damage factors); and (3) the value of  $\beta_0^j$  corresponds to the mean value of the output feature (over all 640 damage identification runs). Figure 11 shows the absolute values of the regression coefficients obtained by least-

square fitting the polynomial in Equation 9 to the mean values (over sets of 20 identification runs) of identified damage factors at different sub-structures. Notice the different scales on the vertical axes of the subplots in Figure 11. From Figure 11, the following observations can be made. (1) For each sub-structure, the regression coefficient corresponding to the mesh size ( $\beta_E^i$ ) has the largest value indicating that E is the most significant input factor in introducing uncertainty in the mean value of the identified damage, which is consistent with the ANOVA results. (2) The regression coefficients for the first two stories are in general smaller than their counterparts for the higher stories, indicating less uncertainty in the mean value of the identified damage factors (i.e., less damage identification bias) at lower stories. (3) Uncertainty of the identified damage due to the first four input factors (M1, M2, M3, S) is not consistent across the different sub-structures.

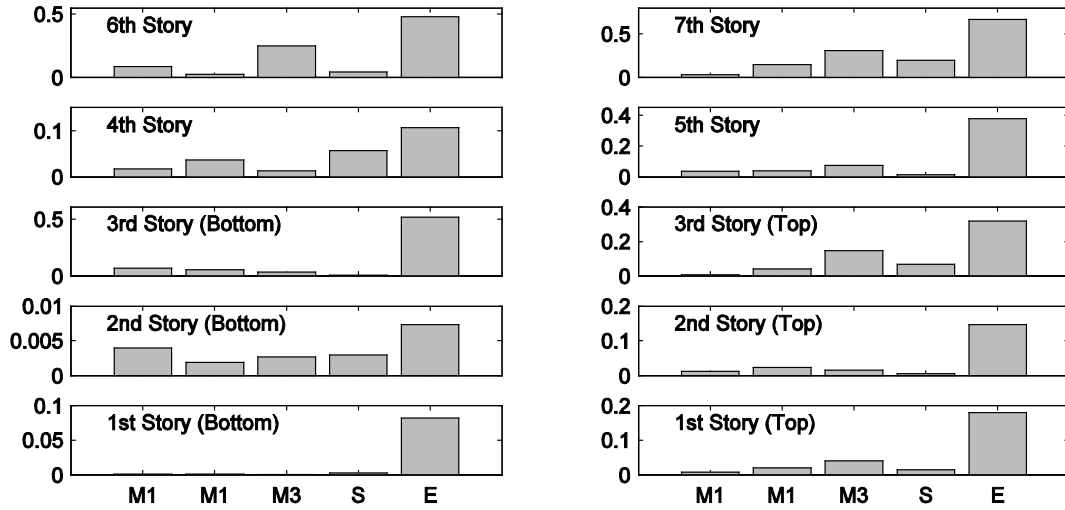

Figure 11. Absolute values of coefficients of the best-fitted polynomials to mean damage factors

### 5.3. One-at-a-Time (OAT) Sensitivity Analysis

In addition to ANOVA and meta-modeling, this study investigates the sensitivity of the identified damage to the level of uncertainty in the identified modal parameters of the first three longitudinal modes. Global sensitivity analysis is performed through one-at-a-time (OAT) perturbation of the individual input factors M1, M2 and M3, which allows investigating the effects of an input factor based on more levels spread



over a wider range. Statistical properties (mean/bias and standard deviation) of the identified damage are investigated for six different levels of uncertainty (0.5, 1.0, 1.5, 2.0, 2.5 and 3.0% COV) in the modal parameters of the mode considered, while the other input factors remain fixed. Values of the other fixed factors are: uncertainty of 0.5% in COV for the modal parameters of the other two longitudinal modes, spatial density of 14 sensors along the web wall, and fine mesh FE model (i.e., 398 elements). A set of 10 identifications is performed for each of the six different levels of uncertainty. The random estimation errors added to the natural frequencies and mode shape components are statistically independent. This global sensitivity analysis of M1, M2 and M3 results in an additional  $3 \times 6 \times 10 = 180$  identification runs. Figure 12 shows the mean and mean  $\pm$  one standard deviation of the identified damage factors at the 10 sub-structures as a function of the OAT perturbation in the uncertainty level of the modal parameters of the three longitudinal modes considered. Each column of subplots corresponds to the perturbation in the uncertainty level of the modal parameters of one vibration mode, while the other input factors remain fixed. From this figure the following conclusions can be made. (1) The mean/bias and standard deviation of the identified damage factors are very little sensitive to the level of uncertainty in the modal parameters of the first longitudinal mode for the range of uncertainty level considered in this study (0.5-3% COV). (2) The mean/bias and standard deviation of the identified damage factors at the first (top) and second (bottom and top) stories increase when the level of uncertainty in the modal parameters of the second mode increases from 0.5% to 1% COV, and remain almost constant for higher levels of uncertainty (1-3% COV). (3) The mean/bias and standard deviation of the identified damage factors at the first (bottom and top), second (bottom), sixth and seventh stories tend to increase monotonically with increasing level of uncertainty in the modal parameters of the third longitudinal mode. In general, the uncertainty level in the modal parameters of the third longitudinal mode has the most significant influence (among the three modes) on the estimation uncertainty (mean and standard deviation) of the damage identification results.

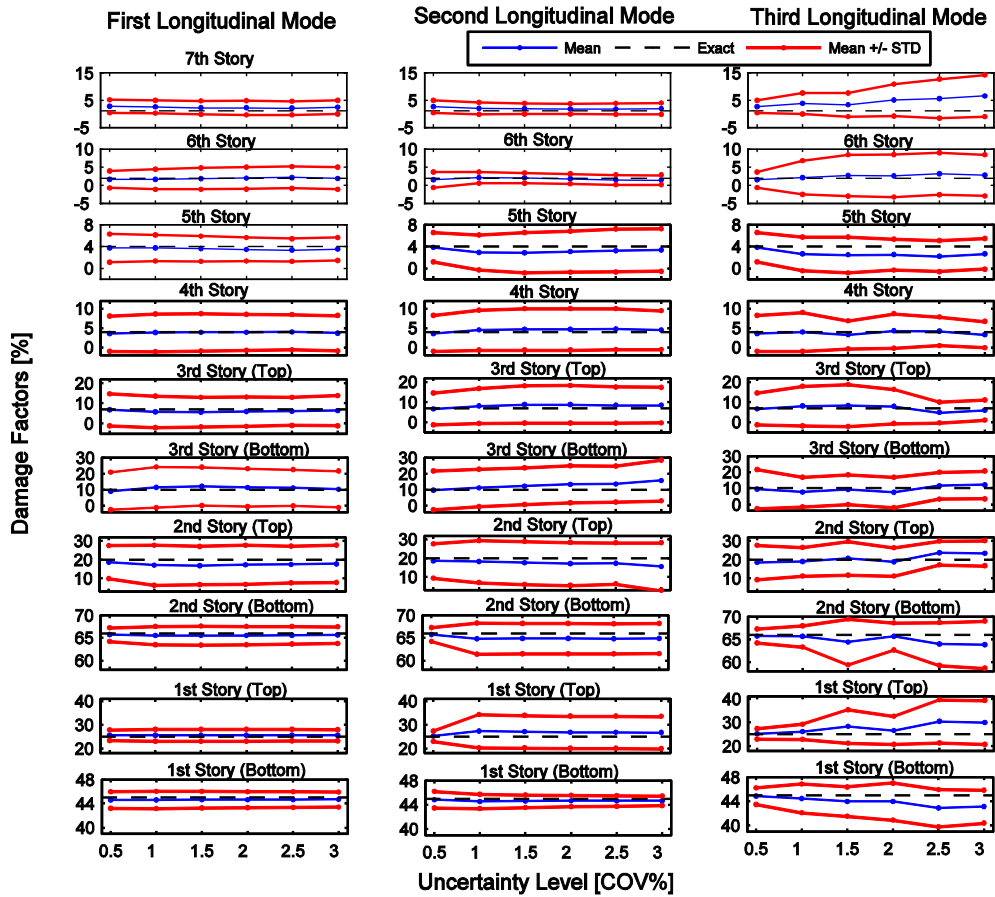

Figure 12. Statistics (mean, mean +/- standard deviation) of the identified damage with increasing level of uncertainty in modal parameters one mode at a time

## 6. Conclusions

In this study, the performance of FE model updating for damage identification of a seven-story building slice is systematically investigated. The damaged structure is simulated numerically through a change in stiffness in selected regions of a FE model of the shear wall test structure. The uncertainty of the identified damage (location and extent) is quantified through analysis-of-variance (ANOVA) and meta-modeling due to variability/uncertainty of the following input factors: (1-3) level of uncertainty in the (identified) modal parameters of the first three longitudinal modes (M1, M2, M3), (4) spatial density of measurements (number of sensors) (S), and (5) mesh size in the FE model used for damage identification (modeling error). A full factorial design of experiments is used in this study, resulting in

$2 \times 2 \times 2 \times 2 \times 2 = 32$  combination of the input factors. For each combination of these five factors, 20 damage identification runs are performed based on modal parameters polluted with statistically independent realizations of the estimation errors, resulting in a total of  $32 \times 20 = 640$  identification runs.

From the results of ANOVA, it was observed that the mesh size (E) is the most significant input factor (within their considered levels of variability) affecting the uncertainty in the mean value (i.e., estimation bias) of the identified damage. From this observation, it can be concluded that even though the modal parameters computed from the two FE models are very close (within 1.2%), i.e., the modal parameters are almost converged, they yield distinct damage identification results, which is mostly due to their different sensitivities to damage. This result also points to the importance of understanding the connection between finite element discretization, computed modal parameters, their sensitivities to structural damage (i.e., sensitivities of modal parameters to updating parameters), and damage identification results. Another interesting observation is that the uncertainty in the modal parameters of the second and third longitudinal modes (M2 and M3) affects more significantly both the mean and standard deviation of the identified damage than the uncertainty in the modal parameters of the first longitudinal mode (M1). This is most likely due to the fact that mode shape curvature is well known to be one of the most sensitive features to local damage and higher modes have higher curvatures. This observation can be used in practice by designing dynamic experiments producing sufficient participation of higher modes and therefore reducing their estimation uncertainty and leading to more accurate damage identification results. In practice, “designing” input excitations with relatively strong amplitude in the frequency range of the higher modes of interest will increase their relative contributions to the total response.

In addition to ANOVA, polynomial meta-models are best-fitted (using least-squares method) to the mean identified damage factors by including all the main factors. From the regression coefficients of the best-fitted polynomials, it was observed that for each sub-structure, the regression coefficient corresponding to the mesh size has the largest value indicating that E is the most significant input factor affecting the mean value of the identified damage, which is consistent with the ANOVA results. Also the regression

coefficients for the first two stories are found to be in general smaller than those for the higher stories, indicating less uncertainty in the mean value of the identified damage factors (i.e., less damage identification bias) at lower stories, where the damage is largest. Finally, sensitivities of the identified damage factors are investigated as a function of the level of uncertainty in the modal parameters of the first three longitudinal modes. This global sensitivity analysis is performed through one-at-a-time (OAT) perturbation of the individual input factors M1, M2 and M3, while the other input factors remain fixed. From this global OAT sensitivity analysis, it is concluded that the uncertainty in the modal parameters of the third longitudinal mode has the most significant influence (among the three modes) on the estimation uncertainty (mean and standard deviation) of the damage identification results.

This systematic investigation demonstrates that the level of confidence in the damage identification results obtained through FE model updating is a function of not only the level of uncertainty in the identified modal parameters, but also choices made in the design of experiments (e.g., spatial density of measurements) and modeling errors (e.g., mesh size). In addition, it is worth noting that the absolute level of uncertainty in the identified damage can become rather large even with typical low modal identification errors (0.5 - 4% COV based on system identification results of the 7-story building), which results in false alarms. This problem is more significant when dealing with relatively low values of damage factors. Based on the results obtained and the experience gained through the study presented herein, it is concluded that probabilistic damage identification methods (e.g., Bayesian FE model updating) are preferable to deterministic methods. Such methods allow to account for all pertinent sources of uncertainty and express the damage identification results in probabilistic terms.

## **ACKNOWLEDGEMENTS**

Partial supports of this research by Lawrence Livermore National Laboratory with Dr. David McCallen as Program Leader and by the Englekirk Center Industry Advisory Board are gratefully acknowledged. Any opinions, findings, and conclusions or recommendations expressed in this material are those of the authors and do not necessarily reflect those of the sponsors. The first author also wants to acknowledge

Mr. Dong Ju Choi of San Diego Supercomputer Center (SDSC) and Dr. Ronnie Hoogerwerf and Mr. Patrick Boyle of Interactive Supercomputing Corporation for their help in performing parallel computations using StarP on the “On Demand Cluster” of SDSC.

## REFERENCES

- Allman, D.J., (1988), A Quadrilateral Finite Element Including Vertex Rotations for Plane Elasticity Analysis, *International Journal for Numerical Methods in Engineering*, Vol. 26, No. 3, 717-730.
- Batoz, J.L., & Tahar, M.B., (1982), Evaluation of a New Quadrilateral Thin Plate Bending Element, *International Journal for Numerical Methods in Engineering*, Vol. 18, No. 11, 1655-1677.
- Christodoulou, K., & Papadimitriou, C., (2007), Structural Identification Based on Optimally Weighted Modal Residuals, *Mechanical Systems and Signal Processing*, Vol. 21, No. 1, 4-23.
- Coleman, T.F., & Li, Y., (1996), An Interior, Trust Region Approach for Nonlinear Minimization Subject to Bounds, *SIAM Journal on Optimization*, Vol. 6, No. 2, 418-445.
- Doebling, S.W., Farrar, C.R., Prime, M.B., & Shevitz, D.W., (1996), *Damage Identification in Structures and Mechanical Systems Based on Changes in Their Vibration Characteristics: A Detailed Literature Survey*. Los Alamos National Laboratory, Rep. No. LA-13070-MS, Los Alamos, New Mexico, USA.
- Doebling, S.W., Farrar, C.R., & Prime, M.B., (1998), A Summary Review of Vibration-Based Damage Identification Methods, *The Shock and Vibration Digest*, Vol. 30, No. 2, 99-105.
- Filippou, F.C., & Constantinides, M., (2004), *FEDEASLab Getting Started Guide and Simulation Examples*. Technical Report NEESgrid-2004-22, <http://fedeeslab.berkeley.edu>.
- Fox, R.L., & Kapoor, M.P., (1968), Rates of Change of Eigenvalues and Eigenvectors, *AIAAJ*, Vol. 6, No. 12, 2426-2429.
- Friswell, M.I., & Mottershead, J.E., (1995), *Finite element model updating in structural dynamics*. Kluwer Academic Publishers, Boston, USA.

He, X., Moaveni, B., Conte, J.P., Restrepo, J.I., & Elgamal, A., (2006), Damage Identification of a Seven-Story Reinforced Concrete Shear Wall Building Tested on UCSD-NEES Shake Table, *Proc. of 4th World Conference on Structural Control and Monitoring*, San Diego, USA.

Hughes, T.J.R., & Brezzi, F., (1989), On Drilling Degree of Freedom, *Computer Methods in Applied Mechanics and Engineering*, Vol. 72, 105-121.

Maeck, J., & De Roeck, G., (1999), Dynamic Bending and Torsion Stiffness Derivation from Modal Curvatures and Torsion Rates, *Journal of Sound and Vibration*, Vol. 225, No. 1, 153-170.

MathWorks Inc., (2005), *Matlab - High Performance Numeric Computation and Visualization Software, User's Guide*. The MathWorks Inc., Natick, MA.

Moaveni, B., Barbosa, A.R., Conte, J.P., & Hemez, F.M., (2007), Uncertainty Analysis of Modal Parameters Obtained from Three System Identification Methods, *Proc. of International Conference on Modal Analysis (IMAC-XXV)*, Orlando, USA.

Moaveni, B., He, X., Conte, J.P., and Restrepo, J.I. (2008a), System Identification Study of a Seven-Story Reinforced Concrete Shear Wall Building Tested on the UCSD-NEES Shake Table, *Journal of Structural Engineering*, ASCE, under review.

Moaveni, B., He, X., & Conte, J.P., (2008b), Damage Identification Study of a Seven-Story Reinforced Concrete Shear Wall Building Tested on the UCSD-NEES Shake Table, *Journal of Structural Engineering*, ASCE, under preparation.

Moaveni, B., He, X., Conte, J.P., & Restrepo, J.I., (2006), System Identification of a Seven-Story Reinforced Concrete Shear Wall Building Tested on UCSD-NEES Shake Table." *Proc. of the 4th World Conference on Structural Control and Monitoring*, San Diego, USA.

Montgomery, M.C., and Runger, G.C. (2007). *Applied Statistics and Probability for Engineers*, 4th Edition. John Wiley and Sons.

Myers, R. H., and Montgomery, D. C. (1995). *Response Surface Methodology*, John Wiley and Sons, Inc., New York, NY.

Navidi, W.C. (2007). *Statistics for Engineers and Scientists*, 2nd Edition. McGraw-Hill.

Panagiotou, M., Restrepo, J.I., & Conte, J.P., (2007), *Shake Table Test of a 7-story Full Scale Reinforced Concrete Structural Wall Building Slice, Phase I: Rectangular Section*. Report No. SSRP-07/07, Department of Structural Engineering, University of California, San Diego.

Pandey, A.K., Biswas, M., & Samman, M.M., (1991), Damage Detection from Changes in Curvature Mode Shapes, *Journal of Sound and Vibration*, Vol. 145, No. 2, 321-332.

Rytter, A., (1993). *Vibration Based Inspection of Civil Engineering Structures*. Ph.D. Thesis, Department of Building Technology and Structural Engineering, Aalborg University, Denmark.

Salawu, O.S., (1997), Detection of Structural Damage through Changes in Frequency: A Review, *Engineering Structures*, Vol. 19, No. 9, 718-723.

Saltelli, A., Chan, K., & Scott, E.M., (2000), *Sensitivity Analysis*. John Wiley & Sons, New York.

Shi, Z.Y., Law, S.S., & Zhang, L.M., (2002), Improved Damage Quantification from Elemental Modal Strain Energy Change, *Journal of Engineering Mechanics*, ASCE, Vol. 128, No. 5, 521-529.

Sohn, H., Farrar, C.R., Hemez, F.M., Shunk, D.D., Stinemat, D.W., & Nadler, B.R., (2003), *A Review of Structural Health Monitoring Literature: 1996-2001*. Los Alamos National Laboratory, Report No. LA-13976-MS, Los Alamos, New Mexico, USA.



Teughels, A., & De Roeck, G., (2004), Structural Damage Identification of the Highway Bridge Z24 by FE Model Updating, *Journal of Sound and Vibration*, Vol. 278, No. 3, 589-610.

Walpole, R.E., Myers, R.H., Myers, S.L., and Ye, K. (2006). *Probability and Statistics for Engineers and Scientists*, 8th Edition. Prentice Hall.

Wu, C.F.J., & Hamada, M., (2000), *Experiments: Planning, Analysis, and Parameter Design Optimization*. John Wiley & Sons, New York.