

Lawrence Berkeley National Laboratory

LBL Publications

Title

A 20 mK TEMPERATURE SENSOR

Permalink

<https://escholarship.org/uc/item/4v58v1qp>

Author

Wang, N.

Publication Date

1987-11-01

e2



Lawrence Berkeley Laboratory

UNIVERSITY OF CALIFORNIA

Physics Division

LAWRENCE
BERKELEY LABORATORY

FEB 1 1988

LIBRARY AND
DOCUMENTS SECTION

Presented at the IEEE Nuclear Symposium,
San Francisco, CA, October 21-23, 1987

A 20 mK Temperature Sensor

N. Wang, B. Sadoulet, T. Shutt, J. Beeman,
E.E. Haller, A. Lange, I. Park, R. Ross,
C. Stanton, and H. Steiner

November 1987

TWO-WEEK LOAN COPY
*This is a Library Circulating Copy
which may be borrowed for two weeks.*

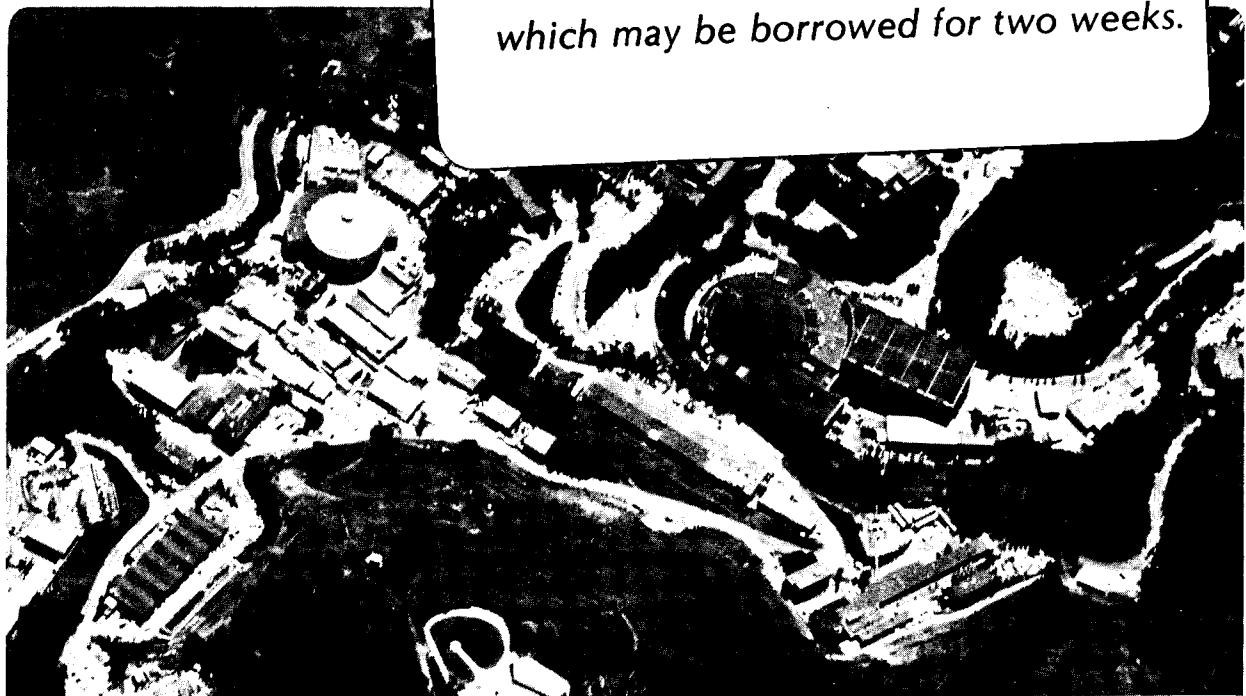

LBL-24301
e2

DISCLAIMER

This document was prepared as an account of work sponsored by the United States Government. While this document is believed to contain correct information, neither the United States Government nor any agency thereof, nor the Regents of the University of California, nor any of their employees, makes any warranty, express or implied, or assumes any legal responsibility for the accuracy, completeness, or usefulness of any information, apparatus, product, or process disclosed, or represents that its use would not infringe privately owned rights. Reference herein to any specific commercial product, process, or service by its trade name, trademark, manufacturer, or otherwise, does not necessarily constitute or imply its endorsement, recommendation, or favoring by the United States Government or any agency thereof, or the Regents of the University of California. The views and opinions of authors expressed herein do not necessarily state or reflect those of the United States Government or any agency thereof or the Regents of the University of California.

LBL-24301

A 20MK TEMPERATURE SENSOR¹

N. Wang, B. Sadoulet, T. Shutt, J. Beeman, E.E. Haller,
A. Lange, I. Park, R. Ross, C. Stanton, H. Steiner

Lawrence Berkeley Laboratory
University of California
Berkeley, CA 94720

November 1987

Presented at the IEEE Nuclear Symposium
San Francisco, CA., October 21-12, 1987

¹This work was supported in part by the U.S. Department of Energy under Contract
DE-AC03-76SF00098

A 20MK TEMPERATURE SENSOR

N.Wang*, B.Sadoulet*, T.Shutt*,
J.Beeman†, E.E.Haller†¶, A.Lange*, I.Park†¶,
R.Ross¶, C.Stanton*, H.Steiner¶
Department of Physics*

Department of Material Science and Mineral Engineering†
Lawrence Berkeley Laboratory¶
University of California, Berkeley, CA 94720

Abstract

We are developing a 20mK temperature sensor made of neutron transmutation doped (NTD) germanium for use as a phonon detector in a dark matter search. We find that NTD germanium thermistors around 20 mK have resistances which are a strong function of temperature, and have sufficient sensitivity to eventually reach a base line rms energy fluctuation of 6eV at 25mK. Further work is needed to understand the extreme sensitivity of the thermistors to bias power.

Introduction

It is believed that 90% of the mass of the universe does not radiate electromagnetic waves. What this "dark matter" is made of is not known, but there have been many suggestions [1,2]. One group of candidates is exotic particles contained in the halo of our galaxy, for instance photinos or heavy neutrinos. Such particles could be detected directly with detectors of a few hundred grams if they can obtain thresholds of a few hundred eV [3]. Phonon detectors appear to be a hopeful technique for the realization of these requirements [4,5].

A thermal detector for phonons [6] in this context consists of an energy absorbing crystal of heat capacity C_a with an attached temperature sensor of heat capacity C_s . The temperature sensor is connected to a heat sink through a thermal link with thermal conductance G_S . When a particle interacts with the detector it will deposit energy in the absorber, where it appears as phonons. These phonons (which are here presumed to be ballistic, although this has not yet been demonstrated) will then transfer a fraction, ϵ , of their heat to the sensor, and are thus detected. With given energy threshold and sensor mass requirements, we can make a rough estimate of the necessary operating temperature based on the system noise. There are several noise sources: thermal noise, Johnson noise, amplifier noise and excess noise, but with good sensor responsivity ($|dV/dT|$ for a thermistor) and with good electronics it should be possible to make the thermal noise dominant. Over a bandwidth B , the latter is given by [7,8] $\delta E_{th} \approx \sqrt{(kT^2C)/\epsilon\sqrt{2\tau B}}$ where C is the effective heat capacity of the system and τ is the thermal time constant ($\tau \approx C/G$). In order to have a low effective heat capacity and to obtain the thresholds required for dark matter detection, for instance, it may well be necessary to work at temperatures near 20 mK. To our knowledge no one has yet demonstrated proper operation of a sensor in this temperature range with a good responsivity.

One possibility for a temperature sensor is a thermistor. Suppose the resistance of the thermistor is a rapidly varying function of the temperature, $R=R(T)$. If the resistor is biased at a constant current, then the voltage variation due to a temperature change is

$$\Delta V = \frac{dV}{dT} \frac{\epsilon \Delta E}{C}$$

where ΔE is the energy deposited in the absorber. For ballistic phonons it could be arranged so that $C = C_s$ (i.e. the heat capacity of the sensor) and ϵ is here more specifically defined as the efficiency of energy transfer from ballistic phonons to electrons in the sensor. (If, on the other hand, the phonons turn out to be thermal, then C is the effective heat capacity of the absorber plus sensor, and $\epsilon = 1$.) We present here the first results on the sensitivity of a thermistor operating at 25 mK.

Sample Preparation

We have tested thermistors made of NTD germanium [9,10] with dopant concentration $n_A - n_D = 6.64 \cdot 10^{16} \text{ cm}^{-3}$. Their dimensions are 1mm x 1mm x 0.25mm. The 1mm² faces are covered with 4000 Å of gold for electrical contact. A boron layer

approximately 2000 Å thick implanted into the germanium beneath the gold assures uniform electrical contact, while a thin layer (500 Å) of palladium between the gold and boron binds these two together. We have chosen the relatively large surface area of these faces (1mm²) because we anticipate eventual detection of ballistic phonons. For ballistic phonons a larger surface between the sensor and the absorber yields a greater efficiency of heat transfer, and hence greater sensitivity.

Figure 1 shows the sample installed on a dilution refrigerator. The sensor is glued with conductive epoxy to a copper-kapton-copper sandwich which is indium soldered to the copper sample holder. The kapton (125 microns thick) provides electrical isolation between the sensor and the refrigerator. The sample holder is then screwed to the mixing chamber which has a base temperature around 20 mK. This design maximizes thermal clamping between the sensor and the heat sink. A 0.7 mil diameter aluminum lead is wedge bonded to the sensor. Aluminum is superconducting at the operating temperatures, therefore the thermal conductance of the wire is very small and little heat flows through it. Lastly, the sensor is completely enclosed in a copper radiation shield which is at the mixing chamber temperature.

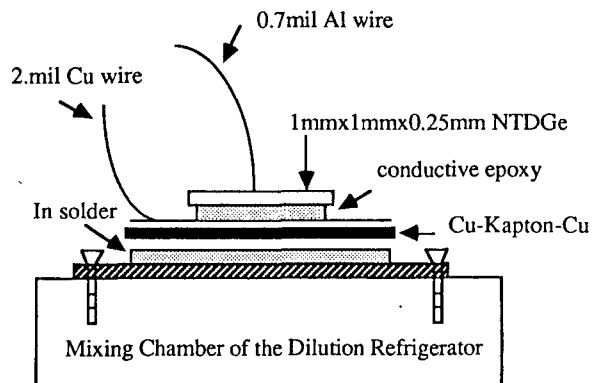

Figure 1. Installation of the thermistor on the mixing chamber of a dilution refrigerator.

Experimental Configuration

Figure 2 is a simple schematic of the circuit used to measure the I-V curves. Because the thermistors have proved to be extremely sensitive to rf heating and microphonics, great experimental care is necessary to reduce these effects. (For instance, as discussed in the next section, 10⁻¹⁴ Watts of bias power causes significant changes in the resistance at 19 mK.) As much as of the experiment as possible is located inside of a screen room, the amplifier is powered by batteries, and all lines leading into and out of the screen room are filtered to reduce external noise. Finally, the experiment is located underground.

The I-V curve is obtained by applying a bias voltage V_{bias} and measuring the resulting voltages across the bias resistor R_{bias} and the sensor resistance R_{bolo} .

Experimental Results

I-V Measurements

Figure 3 shows the I-V curves taken at different mixing chamber temperatures. Note the strong dependence of the zero bias power resistance on this temperature. It has been suggested that the curve should obey the relation $R = R_0 \exp(\Delta/T)$ [11]. In figure 4 we plot the zero power R against T and find that it obeys this prediction over 5 decades. For the sample shown we found R_0

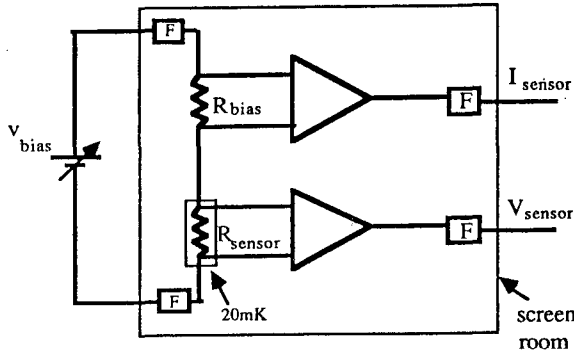

Figure 2. Schematic of the circuit used for I-V measurements
All the lines going into the screen room are filtered.

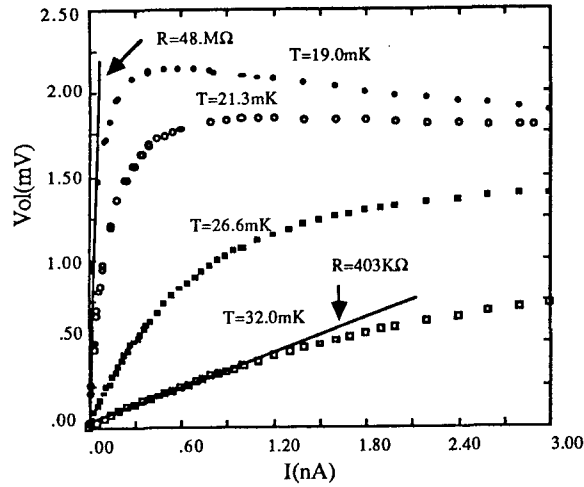

Figure 3. I-V curves of NTD Ge at different mixing chamber temperatures.

= 0.0474 Ohm and $\Delta = 8.151\text{K}$, which is the straight line on the plot. The horizontal error bars reflect a 2% uncertainty in the temperature of the mixing chamber.

More puzzling is the marked deviation from linear behavior at non-zero bias powers, despite the fact that our sensor is well thermally clamped to the heat sink. This is evident in figure 3 and also in figure 5 where we plot the static resistance, V/I , as a function of bias power, IV . Both the degree of curvature of the IV plots and the bias power at which this curvature begins depend strongly on the mixing chamber temperature. Further experiments (to be described elsewhere) suggest that this is indeed not a problem of a poor heat link between the sensor and the heat sink, but rather an intrinsic property of our thermistors. Other groups have seen this effect at higher temperatures [12].

Responsivity dV/dT

These nonlinearities in the IV curves mean that the choice of bias current is very important to obtain maximum thermistor sensitivity. A quantity of interest is the change in voltage with temperature for fixed current, dV/dT , which we shall refer to as the responsivity. It has been obtained from the IV curves by considering the voltage as function of temperature for fixed current. Figure 6 shows the responsivity as a function of the bias power. At each heat sink temperature there is evidently a bias condition which yields optimum sensitivity. In figure 7 we plot this maximum responsivity as a function of heat sink temperature.

AC Measurement

In addition to an understanding of the IV curve, optimum use of thermistors requires knowledge of the thermal noise and thermal conductance, G_s , of the sensor. These can be

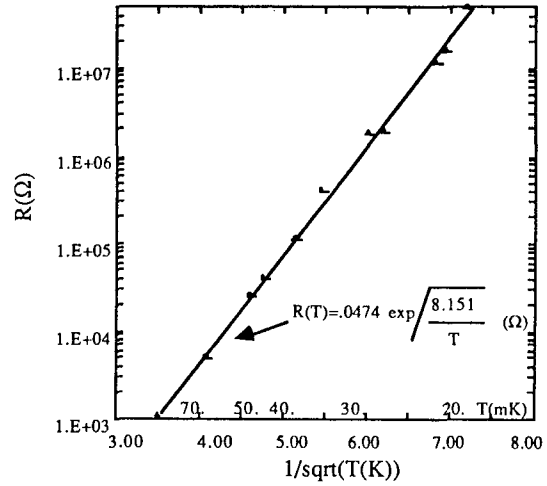

Figure 4. Dependence of the zero bias resistance of NTD Ge on the mixing chamber temperature. These points are from figure 3 and other measurements we performed on the same sample.

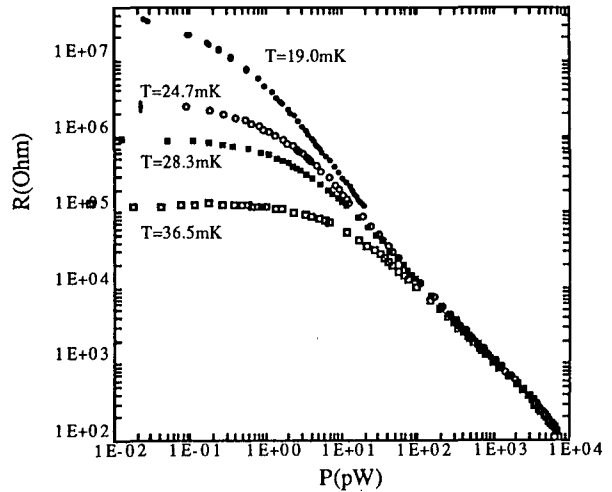

Figure 5. Power ($P=IV$) vs. static resistance ($R=V/I$) for NTD Ge at different mixing chamber temperatures.

obtained from the heat capacity, C_s , and the thermal time constant, τ , which we determined experimentally using an AC pulse measurement technique [13]. A schematic of the circuit is shown in figure 8a. Data was taken with a mixing chamber temperature of 24 mK, and the sensor DC biased at 1.0 nA when the resistance $R=V/I$ was $\approx 2\text{M}\Omega$. Figure 8b shows the bias current as a function of time with an applied square wave. The response of the sensor voltage to this bias current is shown in figure 8c. For a thermistor of heat capacity C and thermal conductance G , using the small signal approximation, the time constant for the voltage relaxation is

$$\tau = \frac{C}{G} \frac{1}{1 - \frac{I^2 \partial R}{G \partial T}}$$

and the initial pulse height ΔV divided by the time constant is

$$\frac{\Delta V}{\tau} = \frac{2I^2 \partial R}{C \partial T} R \Delta I$$

Although we are clearly not in the small signal regime and obviously observe strong nonlinearities, such formulas give us order of magnitude estimates for our sensor of $C_s \approx 0.8 \times 10^{-11} \text{J/K}$ and $G_s \approx 2 \times 10^{-9} \text{W/K}$.

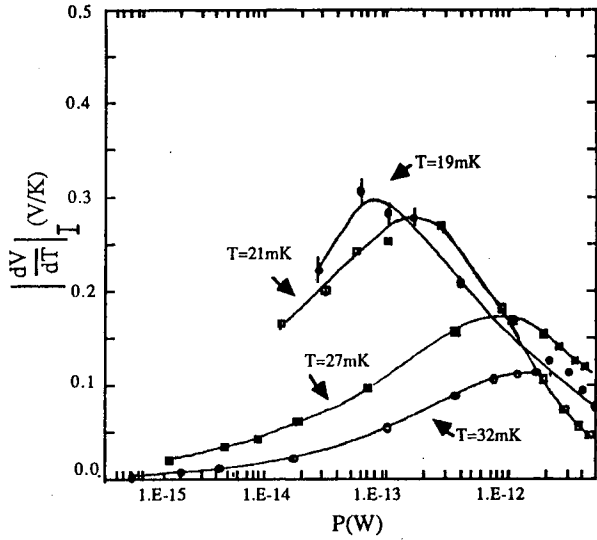

Figure 6. Responsivity $|dV/dT|_1$ vs. power ($P=IV$) of NTD Ge at different mixing chamber temperatures.

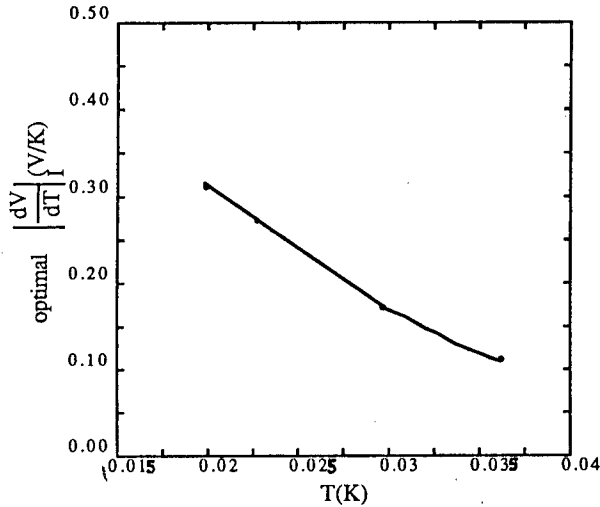

Figure 7. Optimal responsivity vs. mixing chamber temperature, where optimal responsivity is taken to be the maximum value in figure 6.

Minimum Detectable Energy

From the measured responsivity, heat capacity and thermal time constant, we may estimate the sensitivity of our device. If there is no excess noise, then as mentioned above there are three contributions to the baseline energy fluctuation. Fluctuations in phonon number produce energy fluctuations with spectral density $(\delta E)^2 = 4k_B G_s T^2 / (4(\pi f)^2 + 1/\tau^2)$ per Hz, where k_B is Boltzmann's constant, T is the sensor temperature, and G_s is the sensor thermal conductance. For the electronics noise we assume an amplifier noise level of $e_n^2 = (2nV)^2/\text{Hz}$ (which should be obtainable.) The thermistor, since it has resistance R , also has Johnson noise $(\delta V)^2 = 4k_B TR/\text{Hz}$. If we neglect thermal feedback effects, it can be shown in a manner analogous to Mather's noise treatment [7,8], that the energy fluctuation obtained with optimal filtering is

$$\delta E = \frac{\left[\left(\frac{1}{C^2} \left(\frac{\partial V}{\partial T} \right)^2 \frac{2C}{\tau} + \left(\frac{G_s^2}{\tau^2} + 2k_B T R \right) \right) \left(\frac{G_s^2}{\tau^2} + 2k_B T R \right) \right]^{1/4}}{\frac{1}{C} \frac{dV}{dT}}$$

Using the measured values of G_s , C_s , τ , and the responsivity at 24 mK of $|dV/dT| = .25 \text{ V/K}$, we predict an rms energy fluctuation $\delta E = 6 \text{ eV}$. This can be compared, for instance, with the thermal noise alone (integrated over a bandwidth $B = 1/2\tau$) of $\delta E = \sqrt{(k_B T C^2)} \approx 1.6 \text{ eV}$.

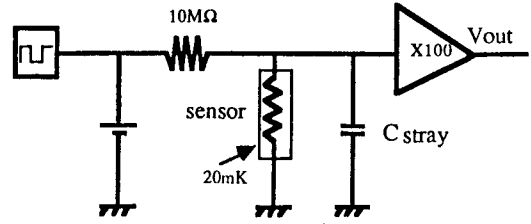

Figure 8.(a)

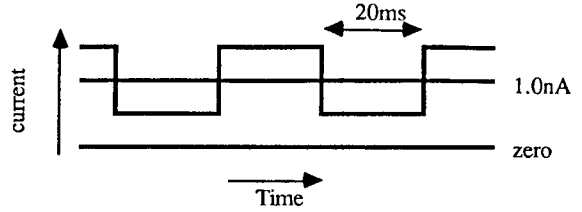

Figure 8.(b)

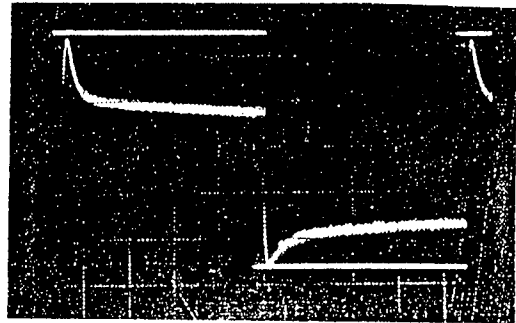

Figure 8.(c)

Figure 8.(a) Schematic of the circuit used for AC measurements, where C_{stray} the stray capacitance. (b) Bias current as a function of time in the AC measurement. (c) Response of the sensor voltage to the bias current shown in figure 8(b).

Conclusion

We have tested a temperature sensor made of NTD germanium at temperatures around 20 mK. We found that the sensor resistance at zero bias as a function of mixing chamber temperature follows the relation $R=R_0 \exp(\sqrt{\Delta/T})$ as low as 19mK. From the observed responsivity $|dV/dT|$, the thermal time constant τ , and the sensor heat capacity C_s , all at 25 mK, we infer an rms energy fluctuation of 6 eV. We are still limited by the responsivity of our device, but our results show that these type of sensors are promising at temperatures as low as 20 mK. More research is needed to determine the nature of the extreme sensitivity of thermistor resistance on bias power, and to find ways to improve the responsivity.

Acknowledgements

We thank J. Clarke, R. Packard for use of their dilution refrigerators, and A. Cleland and J. Davis and Fred Wellstood for help in using them. We gratefully acknowledge support from the U.S Department of Energy under contract DE-AC03-76SF00098.

References

- [1] A.K.Drukier et al., "Detecting Cold Dark-Matter Candidates", Phys.Rev.,D33,pp3495-3508(1986)
- [2] B.Sadoulet, "Prospects for Detecting Dark Matter Particles by Elastic Scattering",
- [3] M.W.Goodman and E.Witten, " Detectability of Certain Dark-Matter Candidates," Phys.Rev., D31,pp3059-3063 (1985)
- [4] D.McCammon et al., "Experimental Tests of a Single-Photo Calorimeter for X-ray Spectroscopy," J.Appl.Phys., vol.56(5), pp1263-1266(1984)
- [5] S.H.Moseley, J.C.Mather, and D.McCammon, "Thermal Detectors as X-ray Spectroscopy," J.Appl.Phys., vol.56(5), pp1257-1262(1984)
- [6] B.Sadoulet, " Cryogenic detectors: hopes and challenges", presented at the IEEE 1987 Nuclear Science Symposium, San Francisco, CA, October 22-24 1987, this volume.
- [7] J.C.Mather, "Bolometers:nonequilibrium theory, " Applied Optics,vol.21,pp1125-1129(1982)
- [8] J.C.Mather, "Bolometers: ultimate sensitivity, optimization, and amplifier coupling, " Applied Optics,vol.23,no.4, pp584-588(1984)
- [9] E.E.Haller, N.P.Palaio, M.Rodder, W.L.Hansen, and E.Kreysa, "NTD Germanium: A Novel Material for Low Temperature Bolometers", proceedings of the 4th International Neutron Transmutation Doping of Semiconductors Conferences, pp21-36(1984)
- [10] A.E.Lange, E.Kreysa, S.E.McBride, and P.L.Richards, "Improved Fabrication Techniques for Infrared Bolometers", International Journal of Infrared and Millimeter Waves, vol.4, no.5, pp689-706(1983)
- [11] See for example H.Fritzsche, "The Metal-Nonmetal Transition in Disordered Systems", L.R.Friedman and D.P.Tunstall eds., Scottish Universities Summer School in Physics(1978)
- [12] Private communications from S.H.Moseley, D.McCammon, T.Kenny, P.L.Richards, and E.Kreysa.
- [13] J.C.Mather, "Electrical Self-calibration of Nonideal Bolometers" Applied Optics, vol.23, no.18, pp3181-3183(1984)

*LAWRENCE BERKELEY LABORATORY
TECHNICAL INFORMATION DEPARTMENT
UNIVERSITY OF CALIFORNIA
BERKELEY, CALIFORNIA 94720*