

## **UC Merced**

# **Proceedings of the Annual Meeting of the Cognitive Science Society**

### **Title**

Tracking the Development of Automaticity in Memory Search with Human Electrophysiology

### **Permalink**

<https://escholarship.org/uc/item/4qb622n2>

### **Journal**

Proceedings of the Annual Meeting of the Cognitive Science Society, 40(0)

### **Authors**

Cao, Rui

Busey, Thomas A

Nosofsky, Robert M

et al.

### **Publication Date**

2018

# Tracking the Development of Automaticity in Memory Search with Human Electrophysiology

Rui Cao (caorui.beilia@gmail.com)

Thomas A. Busey (busey@indiana.edu)

Robert M. Nosofsky (nosofsky@indiana.edu)

Richard M. Shiffrin (shiffrin@indiana.edu)

Department of Psychological and Brain Sciences, Indiana University  
1101 E. Tenth Street, Bloomington, IN., 47405 USA

Geoffrey F. Woodman (geoff.woodman@vanderbilt.edu)

Vanderbilt Vision Research Center, Department of Psychology, Vanderbilt University  
Nashville, TN., 37240 USA

## Abstract

Shiffrin and Schneider (1977) demonstrated that highly efficient memory- and visual-search performance could be achieved through consistent item-to-response mapping (CM) training. It is theorized that subjects shifted from relying on working memory to learned item-response associations in long-term memory (Logan, 1988). The theory was tested and explored mostly through behavioral experiments and computational modeling. In a recent series of articles involving visual search (e.g. Woodman et al, 2013; Carlisle et al. 2011), Woodman and colleagues found that the contralateral-delay activity (CDA) of human event-related potentials is related to the maintenance of information in visual working memory and that the magnitude of the CDA decreases when target information is stored in long-term memory. We employed the CDA and other neural measures to study the nature of memory retrieval in CM memory search tasks. We observed a significant reduction in the magnitude of the CDA in CM training compared to a control condition in which item-response mappings varied from trial to trial (VM). The results provided converging evidence supporting the classic theoretical interpretation of the bases for CM and VM memory search. The results also raised interesting questions concerning the detailed interpretation of CDA.

**Keywords:** Memory search; Old-new recognition; EEG; Automatic processing; contralateral delay activity

## Introduction

For many years researchers have studied the nature of different forms of memory retrieval. Sperling (1960) demonstrated highly accurate retrieval from a short-lived memory termed the visual icon, with subsequent less-accurate retrieval from longer lasting memory stores that had lower capacity. Schneider and Shiffrin (1977) and Shiffrin and Schneider (1977) explored the effects of learning on memory retrieval by varying the way that stimulus-response relations are experienced: They trained using either *varied mapping* (VM) in which the binary responses to a given stimulus varied throughout training, or *consistent mapping* (CM) in which the same response was always assigned to a given stimulus throughout training. VM and CM produced marked differences in performance,

and this was interpreted as changes in the learning of automatic responses, causing changes in attention and memory retrieval. The memory and visual search paradigms they used were associated with large differences in perceived effort, CM coming to seem relatively effortless while VM remained highly effortful throughout training. Logan (1988) emphasized the role of memory retrieval in studies of the learning of alphabet-arithmetic, showing a switch from effortful algorithmic calculation of answers to relatively effortless and fast memory-based retrieval after consistent training.

In recent years, Cao, Shiffrin and Nosofsky (2018; Nosofsky, Cao, et al., 2014) have used VM and CM training to explore in greater detail their role in storage and retrieval in short-term probe-recognition tasks. In their usual paradigm each trial involves presentation of a short list of to-be-remembered items (usually pictures). The study list is followed by a test probe. Subjects respond “old” if the test probe is an item that appeared on the presented list (“targets”); and respond “new” if the test probe is an item that did not appear on the list (“foils”). Note that both targets and foils may have occurred as either study items or test probes on numerous previous lists. Consistent with earlier findings, there were marked differences in performance due to VM versus CM training: VM performance did not improve with training and produced large set size and serial position effects. CM performance showed rapid improvement with training and any set size or serial position effects were greatly reduced. These effects were observed in both accuracy and response times.

To explain the findings of VM and CM training on short-term probe recognition, Cao et al. (2018) used a variant of the “Exemplar Based Random Walk” (EBRW) of Nosofsky and Palmeri (1997). In their modeling approach, study and test-probe exemplars presented on previous trials might be retrieved along with current-list exemplars in driving observers’ old-new recognition judgments. VM training caused storage of previous-trial exemplars with roughly equal numbers of old and new responses, which would lead to interference in making old-new judgments for current-list

items. CM training produced storage of previous-trial exemplars with consistent responses, which would lead to facilitation of performance. Therefore, in VM, an observer would attempt to limit retrieval to current-list items, placing the emphasis on short-term retrieval. But in CM, an observer can rely on long-term memory retrieval of the consistently mapped exemplar-response pairs established throughout training.

Woodman and colleagues (e.g. Carlisle, Arita, Pardo & Woodman, 2011; Woodman, Carlisle & Reinhart, 2013) used a visual-search paradigm in conjunction with EEG measurements to illuminate possibly different forms of retrieval across VM and CM conditions. In their paradigm a single display of a small number of simple visual stimuli (Landolt C's in various orientations) were presented on both sides of fixation, the items to be remembered (targets) being indicated by the color of the stimuli on one side. After the presentation of the cue, the subject was asked to maintain the targets during a delay period, followed by a display of a ring of Landolt C's, which the subject searched for the presence of the studied targets. The researchers observed that, during the delay period, there was a significantly stronger activation from lateral-occipital electrodes on the contralateral side vs. the ipsilateral side of the to-be-remembered item. The difference between contralateral side and ipsilateral side is termed *contralateral delay activity* (CDA; for a recent comprehensive review of the CDA as a neural measure of visual working memory, see Luria et al., 2016; for early evidence, see Vogel & Machizawa, 2004). This CDA signal is stronger when more stimuli must be maintained on one side (e.g. one versus two Landolt C's). Following earlier work, Woodman et al. (2013) suggested the CDA signal provides a measure of the active maintenance of items in short-term visual memory and that it is subjected to top-down attention modulation. In a VM situation in which the to-be-remembered targets varied from trial to trial the magnitude of the CDA remained unchanged from trial to trial. However, in a condition in which the same target repeated for 7 consecutive trials (a form of "local" CM training involving a single item), the magnitude of the CDA signal dropped at each presentation (in another condition it disappeared when subjects searched the same item for an entire session). Carlisle et al. (2011) suggested that in CM long-term memory for the target item could be used, reducing the need to maintain items in visual working memory, thereby reducing the CDA. In VM, no learning could occur, so working memory maintenance was required on every trial.

These findings and interpretations occurred in a task that differed in many ways from our short-term probe-recognition studies described earlier, including the simultaneous versus sequential presentation of the to-be-remembered stimuli; the simplicity of the stimuli (Landolt C's versus pictures of objects); and the number of different stimuli used in the study. For example, in Woodman's CM paradigm, there was only a single target that repeated consecutively across trials, whereas in traditional CM

memory-search studies the test probe is drawn from a large set of stimuli and the specific test probe changes across trials. In this study we therefore returned to a variant of the short-term probe-recognition paradigm, but collected the EEG measures that Woodman found diagnostic in his task. We hoped that the EEG measures could be used to help interpret the differences between VM and CM training.

Participants were presented with short lists of to-be-remembered pictorial stimuli (see Figure 1). The pictures were presented successively on both sides of fixation, one picture on each side. The side of each to-be-remembered item could vary from one visual frame to the next and was indicated by the color of an outline square. This varying presentation-side procedure was adopted in order to reduce subjects' urge to move eyes from fixation, but our interest is on the trials with target stimuli all on one side. In one condition we used VM training for 100 trials (target and foil pictures exchanged roles from trial to trial) and in another condition we used CM training for 100 trials (target and foil pictures maintained their roles over all trials). Our primary interests were in the behavioral accuracy and response time data, and in the CDA measures after each successive item was presented in the study list. (As we will describe, however, we also examined another EEG measure based on Alpha power suppression.) The primary question was whether the CDA signal would be stronger in VM than in CM, providing converging evidence for the differential reliance on STM vs. LTM across these different conditions of memory search. In addition, we were interested in exploring how the CDA signal might vary with memory load in the case in which study items are presented in sequential rather than simultaneous fashion.

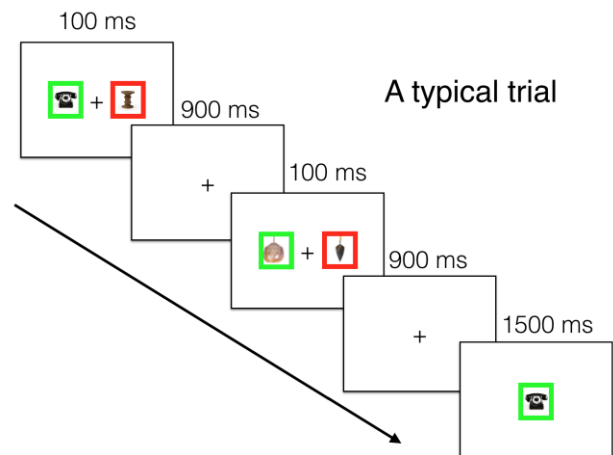

Figure 1: Example of one trial in the experiment (set size 2).

## Experiment

### Methods

**Subjects** 15 Volunteers (20-36 years of age) participated in the experiment in exchange for monetary compensation. All participants had normal color vision, no history of

neurological problems, and normal or corrected-to-normal vision acuity.

**Stimuli** The stimuli were drawn from a pool of 2,400 unique object images obtained from the website of Talia Konkel and described by Bradly, Konkle, Alvarez, and Oliva (2008). Participants viewed the stimuli at a distance of 95 cm, displayed on a grey background with a 0.25 cm thick square that framed each image in either green (RGB value [0 255 0]) or red (RGB value [255 0 0]). The stimuli were presented on a Mac with Psychtoolbox (Brainard, 1997).

**Procedure** Each subject completed two practice blocks (one in the VM condition and one in the CM condition) followed by four EEG recording blocks (two VM blocks and two CM blocks randomly ordered). The practice blocks were meant to familiarize subjects with the test and the CM vs. VM manipulations. Each practice block contained 50 trials and each EEG recording block contained 100 trials. In all conditions, half the test probes were targets and half foils.

For each block, 16 images were sampled without replacement. Subjects were tested on 8 of the images (stimulus-set) and the other 8 images served as filler images during study (filler-set). The filler images were never selected to serve as test probes. There were no overlapping images between blocks. On each trial in the VM condition, a memory set of 2 or 4 items was randomly selected from the stimulus set and the items were presented sequentially for the subject to study. The presentation of the memory set was followed by the presentation of a test probe. Subjects indicated whether the test probe was “old” (a target item that was a member of the study list) or “new” (a foil item that was not a member of the study list) by left clicking or right clicking, accordingly. Test probes that were targets (“old”) were randomly chosen from the memory set; test probes that were foils (“new”) were randomly chosen from the remaining stimulus-set items that were not members of the memory set on the current trial. In the CM condition, 4 items from the stimulus set were randomly selected to serve as “target set” items and these stayed fixed across the block; the remaining items from the stimulus set became the “foil set” and these also stayed fixed. On each trial, a memory set of 2 or 4 items was always randomly selected from the target set. Just as in the VM condition, the items were presented sequentially for the subjects to study, and this study list was then followed by a test probe. Test probes that were targets (“old”) were randomly chosen from the memory set; test probes that were foils (“new”) were always randomly chosen from the fixed foil set.

A schematic illustration of a typical trial with set size two is presented in Figure 1. Subjects started each trial by clicking both keys of the mouse when a letter “B” was displayed at the center of the screen (visual angle of 0.2°). After a 500 ms delay, the memory set items were presented sequentially, each accompanied with a filler image that was randomly selected from the filler set. Each image was 10cm x 10cm in size. The memory set item and the filler image

were simultaneously presented with one image on the right side and the other image on the left side of the fixation point (the inner boarder of each image was 5cm away from the fixation point; the visual angle to the center of the image is 6.37°). The images were distinguished with color frames (red vs. green) and subjects were instructed to pay attention only to images framed by the task-relevant color (fixed across all blocks). In 50% of the trials, the study items stayed at the same side of the fixation point across the sequential presentation of the memory set; in the remaining 50% of trials the side of the study items was chosen randomly on each sequential presentation. In total, roughly 67% of trials were stay trials. The images were presented for 100ms followed by 900ms with just the fixation point. Following the presentation of the last memory set item, there was a 1000ms delay, after which a test probe was presented. The test probe (half the time a target) was presented at the center of the screen with the target-color frame. The test probe remained on the screen for 1.5 s or until the subject clicked the mouse key to make a response. Feedback was then provided with tunes in different pitch: high pitch indicated a correct response; low pitch indicated an incorrect response; a burst of three tunes indicated a slow response.

Prior to the practice blocks, subjects were informed of the task-relevant color (red or green, counterbalanced between subjects) and of the nature of the memory search task without information regarding the CM vs. VM manipulation. After completing the practice blocks, subjects were asked to verbally describe to the experimenter the difference between the 2 blocks and were informed about the CM vs. VM manipulation. After EEG net capping, each subject was asked to perform 6 eye-blink trials and 24 horizontal eye-movements (with 4 trials for each of 2.67, 5.15 and 10.29 degrees of eye-movements to the left or right of the center of the screen) before the start the memory search task.

### **Electroencephlogram acquisition and pre-processing**

The electroencephalogram (EEG) was sampled at 32 channels at 1000hz and down sampled to 500hz. The signals were amplified by a factor of 20,000 using Sensorium amplifiers with an analog bandpass filter of 0.01-100HZ. Eye-movements were monitored with electrodes 2 cm away from the eyes to capture horizontal eye-movements and an electrode was placed under the right eye to detect eye-blinks and vertical eye-movements. The data was later low-pass filtered below 50hz.

For each trial, the EEG data were collected 500ms prior to the onset of the first study item and 1500ms after the onset of the test probe. We used three steps to remove artifacts from the average ERP. The horizontal EOG from the instructed eye-movement trials were used to generate a linear function of degrees of eye-movement; we rejected trials with at least 4 degrees of horizontal eye-movement during the presentation of the memory set. In addition, two subjects were rejected for excessive eye-movement (>35% of trials). Research assistants in the lab also rejected any

trials with obvious artifacts. EEGLab toolbox (Delorme & Makeig, 2004) was employed for EEG data analysis. For the 13 remaining subjects, an average of 14% trials were removed. Independent Component Analysis (ICA) was used to identify artifacts including eye-blinks, eye-movement, and muscle activity. The artifacts were subtracted from the raw EEG data prior to ERP analyses and Alpha power analyses. Due to the relatively low frequency of error trials (resulting in inadequate statistical power), we included only correct trials in the EEG analyses.

### Behavioral Results

In Figure 2 we plot the probability of errors and the mean response time (RT) for correct trials as a joint function of condition (CM vs. VM), test-probe type (target vs. foil), and memory set size (2 vs. 4). The results are consistent with patterns observed in many previous studies of VM and CM memory search: RTs are much shorter and error rates are much lower in the CM condition than in the VM condition. Most importantly, while VM error rates and RTs increased strongly with set size, CM performance stayed the same across set sizes. Such results indicate that the paradigmatic changes made in order to implement this EEG experiment did not alter the usual pattern of behavioral results.

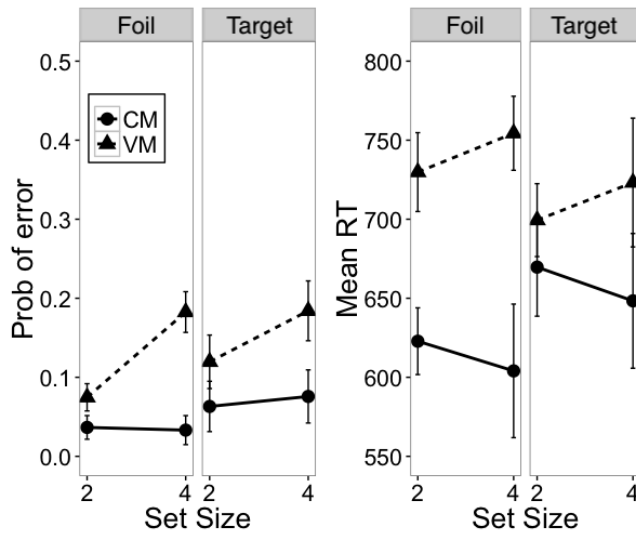

Figure 2. Probability of error (left panel) and mean correct response time (right panel) as function of condition (CM, VM), set size (2, 4) and probe type (foil, target)

To analyze the data, we applied a 2 (CM, VM) x 2 (Target, Foil) x 2 (set size 2, 4) repeated measure ANOVA to both the accuracy and RT data. For the accuracy data, the effects of both condition ( $F(1,12)=12.25, p=0.004$ ) and set size ( $F(1,12)=39.13, p<0.001$ ) were significant. The interaction between condition and set size ( $F(1,12)=41.81, p<0.001$ ) was also significant, reflecting that set size had a big impact in the VM condition but not in the CM condition. For the RT data, the main effect of conditions was significant ( $F(1,12)=10.29, p=0.008$ ); as was the interaction

between condition and test probe (Target vs. Foil) ( $F(1,12)=18.21, p<0.001$ ). The interaction reflects that RTs increased with set size in the VM condition but not in the CM condition.

### EEG Analyses

**CDA Analyses** In Figures 3A and 3B we show the average waveforms of lateral occipital-temporal electrodes (PO3/4, O1/2, PO7/8, P7/8), collapsed based on their relative locations to the stimuli during memory-set presentation (i.e., ipsilateral vs. contralateral). (Figure 3A shows the results for the set-size-4 trials, and Figure 3B for the set-size-2 trials.) To avoid any complications arising from conflicting CDAs due to swapping sides, we analyzed only those trials where the target stimuli stayed at the same side of fixation. The space between the contralateral waves and the ipsilateral waves measures the CDA. As shown in the figure, for both set sizes, the CDA is observed in both the CM and VM conditions, although the magnitude of CDA is reduced in the CM condition compared to the VM condition. To bring out this result more clearly, in Figure 3C we plot the CDA in the CM and VM conditions for the first and second study items, averaged across the set-size-4 and set-size-2 conditions.

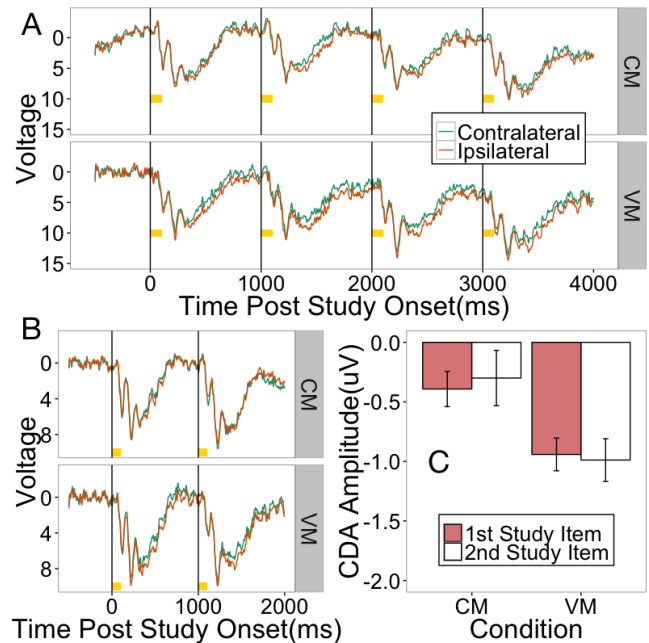

Figure 3. CDA signals in the experiment. A. Grand average waveforms from lateral occipital-temporal electrodes for set size 4. The vertical black lines indicate onset of each study item and the yellow shades indicate the duration of study item presentations (same applies to B). B. Grand average waveforms from lateral occipital-temporal electrodes for set size 2. C. Grand average of CDA in the time period 300-1000 ms post the onset of the first and second study item.

We performed a 2 (CM vs. VM) x 2 (Contralateral vs. Ipsilateral) x 2 (set size 2 vs. 4) repeated ANOVA of the

averaged electrodes voltage during the 300-1000ms epoch after the onset of each study item. We found a significant main effect of relative sides (Contralateral vs. Ipsilateral,  $F(1,12)=23.2$ ,  $p<0.001$ ). Most important, the interaction between relative sides and condition was also significant ( $F(1,12)=6.63$ ,  $p=0.024$ ), reflecting the reduced CDA in the CM condition compared to the VM condition.

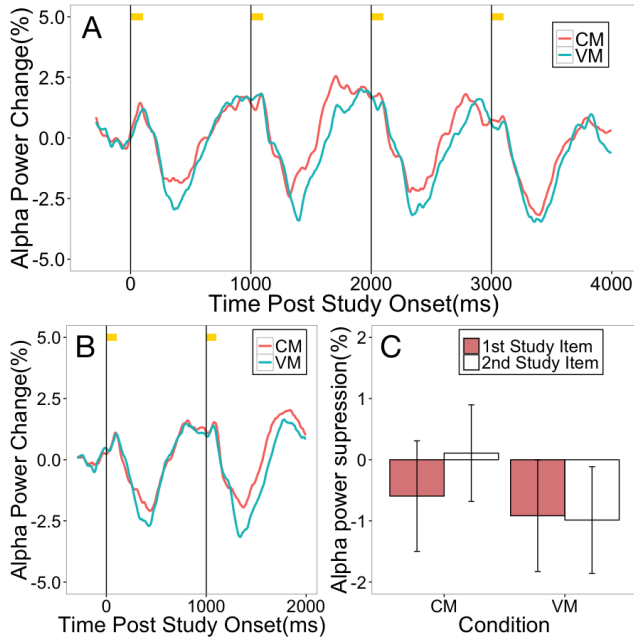

Figure 4 Alpha-power change during study. A. Grand average waveforms from lateral occipital-temporal electrodes for set size 4. The vertical black lines indicate onset of each study item and the yellow shades indicate the duration of study item presentations (same applies to B). B. Grand average waveforms from lateral occipital-temporal electrodes for set size 2. C. Grand average of alpha power suppression in the time periods 300-1000 ms post the onset of the first and second study item.

**Alpha Power Suppression** Researchers have shown that suppression of alpha power is associated with load in short-term memory (Fukuda & Woodman, 2017). Therefore, we decided to assess suppression of Alpha power in our study. EEG from parieto-occipital channels (P3/4, PO3/4, O1/2, Pz) of each trial was subjected to spectral decomposition using EEGLAB function “newtimef” with 3 cycles per morlet wavelet. We define the baseline as the mean Alpha power spectrum (8-13 HZ band) during the pre-trial time window (-500 to 0ms relative to the onset of the first study item). The percentage change of Alpha power for the memory set presentation relative to the baseline is then plotted in Figure 4. The average change of Alpha power is collapsed across electrodes from both sides of the scalp. (We also examined the Alpha power change separately for electrodes located contralateral vs. ipsilateral to the study items and found no difference in the pattern of results.) As shown in the figure, Alpha power reduced substantially after the onset of each study item and there appears to be more

reduction in the VM condition than in the CM condition. We averaged the change of Alpha power from baseline over the epoch of 300-1000ms after the onset of each study item. We performed a 2 (CM vs. VM) x 2 (set size 2 vs. 4) repeated ANOVA for the mean change of alpha power. The effect of condition was marginally significant ( $F(1,12)=3.2$ ,  $p=0.099$ ). None of the interactions were significant. Although the noise in these data makes any strong conclusions difficult, the results are consistent with those from the CDA analyses in showing greater Alpha power suppression in VM than in CM.

**Effects of increasing the short-term memory load** The VM behavioral data show a decline in performance when load increases from two to four items to be remembered, a universal finding in the field. There is no hint, however, of an increase in the CDA as additional items are presented for study. This observation is supported by statistical test: A pairwise t-test (first vs. second study item) of average CDA over 300-1000ms after the onset of each study item revealed no evidence of a difference ( $t<1$ ). There is also very little evidence for an increase in alpha power suppression as additional items are presented. Such findings suggest a refinement of the interpretation of the meaning of the CDA and alpha power suppression findings. We suggest they show load effects for the amount of information that an observer attempts to actively and simultaneously maintain in visual working memory. Under our conditions of testing, observers may have tried to actively maintain only the most recently presented item, without attempts to actively maintain the previous study items. Much future research will be needed to test this and numerous other possibilities.

## DISCUSSION

Limits on capacity of short term memories, defined by numbers of distinct items or by persistence, have been acknowledged and studied since the first days of psychology. Schneider and Shiffrin (1977) and Shiffrin and Schneider (1977) showed how consistent practice could overcome such limits through the development of automaticity, with a likely mechanism involving the retrieval from long-term memory of stored instances of the consistently mapped item-response pairs (e.g. Logan, 1988). Both these results are seen in the behavioral results from the present studies of probe-recognition memory search. The VM conditions show the effects of load or capacity limitations, with observers performing worse in cases in which four rather than two items are held in memory. This decline in performance was observed for both accuracy and response time measures. By contrast, as a result of consistent practice, the effects of memory load were greatly reduced in the CM conditions.

Recent years have seen the discovery of neural measurements that signify the presence of short-term memory load and capacity limitations. A few are based on EEG measures, including the CDA that was the focus of the present investigation (Carlisle et al., 2011; Luria et al.,

2016; Vogel & Machizawa, 2004; Woodman et al., 2013). The CDA is correlated with the amount of material being held in at least one kind of short-term visual memory. Researchers have shown not only a dependence of the CDA upon the demands for memory maintenance, but also a reduction of the CDA in CM practice conditions in which a single stimulus was repeatedly mapped to the same response (Carlisle et al., 2011; Reinhart, Carlisle, & Woodman, 2014; Reinhart & Woodman, 2014). Recent work has also indicated that the magnitude of alpha-band suppression can provide a reliable neural metric of storage in visual working memory (e.g., Fukuda, Kang, & Woodman, 2016; Fukuda & Woodman, 2017); thus, we also quantified this activity.

Here we measured EEG while subjects were sequentially shown a substantial number of complex pictures, and with considerable training in both VM and CM, deviating from previous work in these regards. Both the CDA and the amount of alpha power suppression were measured after each presentation of the study items. Both the magnitude of CDA and alpha suppression were greater for VM than CM. These results were consistent with the hypothesis derived from behavioral and formal modeling work that practice under the present kinds of CM conditions did indeed reduce the demands for short term memory capacity. Furthermore, previous demonstrations of the reduced CDA under CM conditions involved the repetition of only a single target item across consecutive trials. Our results generalize that finding by showing a reduced CDA under CM conditions involving large sets of to-be-remembered stimuli and in which the test probes are spaced throughout the entire training block.

One other finding, however, was not expected a priori: In VM, as additional pictures were presented sequentially, the size of the CDA and the amount of alpha suppression did not increase, despite the behavioral evidence that load in short-term memory was increasing. As noted earlier, a number of studies using CDA have shown that an increase in memory load increases the CDA. There are several possible explanations for the difference in findings between the present experiment and previous studies of the CDA. One possibility is that the CDA measures the load associated with attempts to actively maintain multiple items, whereas in our probe-recognition experiments the subjects may have tried to actively maintain only the most recently presented item. We plan to pursue this and other possibilities in future research.

### Acknowledgement

This research was supported by AFOSR grant FA9550-14-1-0307 to RMN; GFW was supported by National Institutes of Health grants R01-EY019882, R01-EY025275, R01-MH110378, P30-EY08126, and T32-EY007135.

### References

Brady, T. F., Konkle, T., Alvarez, G. A., & Oliva, A. (2008). Visual long-term memory has a massive storage capacity for object details. *Proceedings of the National*

- Academy of Sciences, USA*, 105, 14325–14329.
- Brainard, D. H. (1997). The Psychophysics Toolbox. *Spatial Vision*, 10, 433–436.
- Cao, R., Shiffrin, R. M., & Nosofsky, R. M. (2017). Item frequency in probe-recognition memory search: Converging evidence for a role of item-response learning. *Memory & cognition*, 1-14.
- Carlisle, N. B., Arita, J. T., Pardo, D., & Woodman, G. F. (2011). Attentional templates in visual working memory. *Journal of Neuroscience*, 31, 9315–9322.
- Delorme, A. & Makeig, A. (2004) EEGLAB: an open source toolbox for analysis of single-trial EEG dynamics. *Journal of Neuroscience Methods* 134:9-21.
- Fukuda, K., Kang, M.-K., & Woodman, G. F. (2016). Distinct neural mechanisms for spatially lateralized and spatially global working memory representations. *Journal of Neurophysiology*, 116, 1715-1727.
- Fukuda, K., & Woodman, G. F. (2017). Working memory buffers information retrieved from human long-term memory. *Proceedings of the National Academy of Sciences*, 114(20), 5306-5311.
- Logan, G.D. (1988). Toward an instance theory of automatization. *Psychological Review*, 95, 492-527.
- Luria, R., Balaban, H., Awh, E., & Vogel, E. K. (2016). The contralateral delay activity as a neural measure of visual working memory. *Neuroscience & Behavioral Reviews*, 62, 100-108.
- Nosofsky, R.M., Cao, R., Cox, G.E., & Shiffrin, R.M. (2014). Familiarity and categorization processes in memory search. *Cognitive Psychology*, 75, 97-129.
- Nosofsky, R. M., & Palmeri, T. J. (1997). An exemplar-based random walk model of speeded classification. *Psychological Review*, 104(2), 266-300.
- Reinhart, R. M. G., Carlisle, N. B., & Woodman, G. F. (2014). Visual working memory gives up attentional control early in learning: Ruling out inter-hemispheric cancellation. *Psychophysiology*, 51(800-804).
- Reinhart, R. M. G., & Woodman, G. F. (2014). High stakes trigger the use of multiple memories to enhance the control of attention. *Cerebral Cortex*, 24, 2022-2035.
- Schneider, W., & Shiffrin, R. M. (1977). Controlled and automatic human information processing: I. Detection, search, and attention. *Psychological Review*, 84, 1-66.
- Shiffrin, R. M., & Schneider, W. (1977). Controlled and automatic human information processing: II. Perceptual learning, automatic attending, and a general theory. *Psychological Review*, 84, 127-190.
- Sperling, G. (1960). The information available in brief visual presentations. *Psychological Monographs: General and Applied*, 74(11), 1-29.
- Vogel, E. K., & Machizawa, M. G. (2004). Neural activity predicts individual differences in visual working memory capacity. *Nature*, 428(6984), 748-751.
- Woodman, G. F., Carlisle, N. B., & Reinhart, R. M. (2013). Where do we store the memory representations that guide attention?. *Journal of Vision*, 13(3), 1-1.