

Lawrence Berkeley National Laboratory

Recent Work

Title

ENZYMATIC UTILIZATION OF WASTES CELLULOSIC

Permalink

<https://escholarship.org/uc/item/4q00j7rv>

Authors

Mitra, Gautam
Wilke, C.R.

Publication Date

1974

c.2

ENZYMATIC UTILIZATION OF WASTE CELLULOSICS

Gautam Mitra* and C. R. Wilke

January 1975

Prepared for the U. S. Atomic Energy Commission
under Contract W-7405-ENG-48

* Filed as a Ph. D. thesis

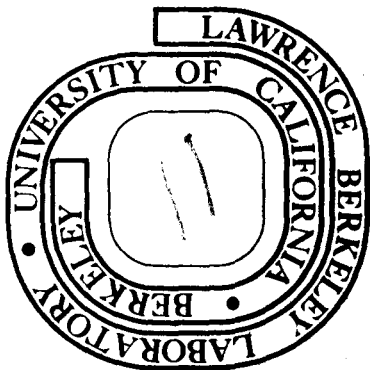

TWO-WEEK LOAN COPY

This is a Library Circulating Copy
which may be borrowed for two weeks.
For a personal retention copy, call
Tech. Info. Division, ~~Ext. 5545~~

c.2

DISCLAIMER

This document was prepared as an account of work sponsored by the United States Government. While this document is believed to contain correct information, neither the United States Government nor any agency thereof, nor the Regents of the University of California, nor any of their employees, makes any warranty, express or implied, or assumes any legal responsibility for the accuracy, completeness, or usefulness of any information, apparatus, product, or process disclosed, or represents that its use would not infringe privately owned rights. Reference herein to any specific commercial product, process, or service by its trade name, trademark, manufacturer, or otherwise, does not necessarily constitute or imply its endorsement, recommendation, or favoring by the United States Government or any agency thereof, or the Regents of the University of California. The views and opinions of authors expressed herein do not necessarily state or reflect those of the United States Government or any agency thereof or the Regents of the University of California.

ENZYMATIC UTILIZATION OF WASTE CELLULOSICS

Table of Contents

Abstract	vi
Acknowledgements	xii
1. Introduction	1
1.1 Background	1
1.2 Rationale for the Present Investigation	3
2. Cellulases and Their Applications	8
2.1 Structural and Morphological Characteristics of Cellulose	8
2.2 Degradation of Insoluble Cellulose	9
2.3 C ₁ -C _x Components of Cellulase and Their Mode of Action	11
2.4 Degradation of Soluble Cellulose	15
2.5 Kinetics of Enzymatic Breakdown of Cellulose	18
2.6 Kinetics of Enzymatic Breakdown of Oligosaccharides	22
3. Experimental Procedures	28
3.1 Assay Procedures	28
3.1.1 Enzyme Activity Assay	28
3.1.2 Cellulose Assay	29
3.1.3 Reducing Sugar Assay	30
3.1.4 Protein Assay	32
3.1.5 Q _{O₂} Measurement	37

3.2	Enzyme Production	39
3.3	Ultrafiltration	46
3.3.1	Background	46
3.3.2	Theory	49
3.3.3	Experimental Technique	53
3.4	Gel Filtration	55
3.4.1	Background	55
3.4.2	Theory	57
3.4.3	Experimental Technique	60
4.	Results and Discussions	66
4.1	Enzyme Characteristics	66
4.2	Growth of the Fungus and Enzyme Production	78
4.2.1	Development of a Low Cost Growth Medium	78
4.2.2	Q_{O_2} Measurement	82
4.2.3	C. S. T. R. Runs with Soluble Sugars	86
4.2.4	Batch Growth and Enzyme Production on Insoluble Substrate	91
4.2.5	Two Stage C. S. T. R. Runs of Enzyme Production	94
4.2.6	Separation of Enzyme from Solids Following Enzyme Production	100
4.3	Enzymatic Hydrolysis of Newsprint	102
4.4	Enzyme Recovery and Reuse	110
5.	Process Design and Economic Evaluation.	121
5.1	Design Basis	121
5.2	Description of the Process	122
5.3	Energy Requirement for the Process	126

5.4 Economic Evaluation 131

5.5 Suggestions for Future Study 147

Appendices

Appendix A: Hydrolysis 149

Appendix B: Calibration Curve for Solid Feeder 177

Calibration Curve for Rotameter 177

ENZYMATIC UTILIZATION OF WASTE CELLULOSICS

Gautam Mitra* and C. R. Wilke

Department of Chemical Engineering
Lawrence Berkeley Laboratory, University of California
Berkeley, California 94720

ABSTRACT

On the land area of the earth about 1.6×10^{10} tons of carbon are fixed every year by photosynthesis out of which about half appears in the form of cellulose. Hydrolysis of one pound of cellulose theoretically yields 1.11 lb. glucose which is equivalent to 0.56 lb. of ethyl alcohol. In the North American continent large amount of cellulosic wastes are available for economic processing (1, 2, 3) with their energy equivalence almost equal to a fifth of current U. S. gasoline consumption (4).

In recent years cellulose degradation through enzymatic means has been investigated by various workers (5, 6, 7), the hydrolysis products being a mixture of simple reducing sugars. These investigations, however, have mostly been confined to the realm of basic research. This study presents experimental results on different aspects of the integrated process culminating in an economic process designed for manufacturing reducing sugar solution by enzymatic hydrolysis of waste cellulosic material.

* Present Address: Cutter Laboratories, Berkeley, California.

The cellulose molecule is a high molecular weight polymer of β -1, 4 linked D-glucose residues. The chemical structure is represented as follows:

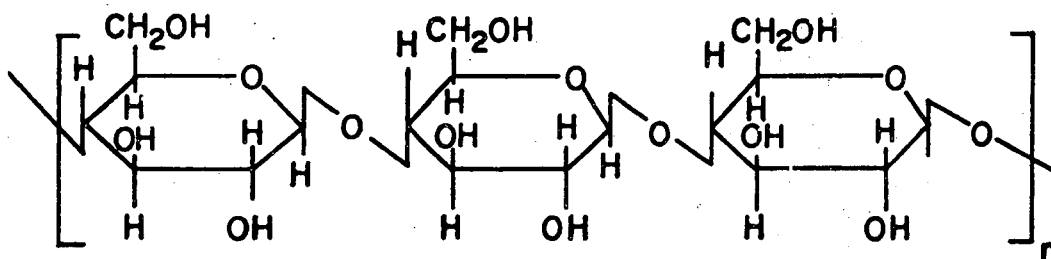

Degree of polymerization varies widely depending upon its origin. For chemical pulp and filter paper the degree of polymerization generally varies between 500 and 1000 whereas in wood cellulose it is about 8000-10,000. During enzymatic hydrolysis by cellulase enzyme β -1, 4 glucosyl bonds are split to produce reducing sugars according to

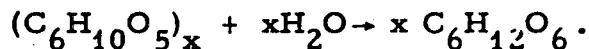

The term "cellulase" is used to designate a complex system of enzymes (molecular weight range 12,000-68,000) showing various types of activities with respect to different kinds of substrates. The mechanism of degradation of crystalline cellulose by enzymatic means has been the object of intense study for the last 25 years. The most accepted postulate in this area has been the 2-step C_1 - C_x theory proposed by Reese et al., (8). According to this theory the C_1 component

of the enzyme first desintegrates the cellulose chain prior to its solubilization. The subsequent hydrolytic action at the β -1, 4 linked glucosyl bonds of the solubilized chain is attributed to the C_x component of the enzyme. Certain micro-organisms grow only on soluble cellulose, such as carboxymethyl cellulose, and synthesize only C_x components, whereas other microorganisms are capable of growing on highly ordered forms of cellulose and produce both C_1 and C_x . The fungus, Trichoderma viride was selected for the present study because of its high C_1 productivity during growth on insoluble cellulose (5, 7) along with an adequate production of C_x .

Cellulase activities are measured by interacting a given substrate with the enzyme and measuring the amount of reducing sugar produced in a given time. The tests are as follows:

C₁-Cotton: This test measures C_1 activity; 50 mg of adsorbent cotton is added to 1 ml appropriately diluted enzyme and 1 ml of 0.05 M sodium citrate buffer at pH 4.8. Reaction is carried out at 50°C for 24 hours and amount of reducing sugar produced measured by dinitrosalicylic acid test.

Filter Paper Activity: This test measures combined C_1 - C_x activity. Fifty mg (1 × 6 cm) of Whatman filter paper no. 1 is added to a mixture of 1 ml of appropriately diluted enzyme and 1 ml of 0.05 M sodium citrate buffer at pH 4.8. Reaction is carried out at 50°C for 1 hour and reducing sugar concentration determined by dinitrosalicylic acid test.

C_x Activity: This test determines $\beta(1-4)$ glucanase activity. To 0.5 ml of 1.0% carboxymethylcellulose (CMC, 50T, Hercules Powder Co.) in 0.05 M sodium citrate buffer (pH 4.8) 0.5 ml of appropriately diluted enzyme is added and reaction carried out at 50° C for 1/2 hour followed by reducing sugar determination by dinitrosalicylic acid test.

Trichoderma viride, a highly productive mutant developed at the U.S. Army Laboratory at Natick, Massachusetts, was grown in a fermentation system (Figure 7) for the production of cellulase. Enzyme characteristics were examined in a stirred ultrafiltration cell and gel filtration column. Strong synergistic action among various fractions of C_x above and below molecular weight of 30,000 was noticed. C₁ activity was strongly dependent upon simultaneous presence of C_x activity in the enzyme solution. A low cost growth medium was developed (Figure 18). For the growth of the fungus, substituting chemical grade analytical reagents with commercial fertilizers. Specific oxygen demand for fungal growth on soluble sugars was determined to be $1.04 \frac{\text{millimoles oxygen}}{\text{gm. dry weight} \times \text{h}}$. Single stage C. S. T. R. runs (Figure 21) with 1% soluble sugar yielded a maximum cell productivity of $0.92 \frac{\text{mg. dry weight}}{\text{ml} \times \text{hr}}$ at a dilution rate of 0.21 hr^{-1} . The corresponding maximum specific growth rate from unsteady state observations (Figure 20) was found to be 0.294 hr^{-1} . Two stage C. S. T. R. runs were conducted with cell growth on glucose in the first stage and enzyme induction by cellulose addition in the second stage. From the results shown in Figure 24 the enzyme productivity for this mode of operation was determined to be $27.3 \times 10^{-3} \frac{\text{Filter paper activity}}{\text{ml} \times \text{hr}}$.

1% dextrose as growth medium and 1% pure cellulose as inducer.

Hydrolysis of -200 mesh ball milled newsprint at 50° C and 4.80 pH with enzyme of 2.70 F.P. activity resulted in 82% conversion of cellulose in 40 hours. Adsorption characteristics of the enzyme on the fully ground solids and on the spent solids following hydrolysis were experimentally measured (Figure 31, Figure 32) at 50° C. Based on the experimental data a process for manufacturing reducing sugar solutions from waste paper was formulated.

Economic analysis was carried out for this process with a waste cellulosic feed of 833 tons/day (dry basis). Excluding the cost of the waste cellulose the net manufacturing cost for reducing sugars was estimated at ³ ~~1~~4/lb with a total plant investment of \$10,134,000.

References

1. First Annual Report of the Council on Environmental Quality, U.S. Congress, 1970.
2. Chemical Week, 109(13), 21 (1970).
3. Wiley, A. O., Ind. Eng. Chem., 47, 1397 (1955).
4. Shreeve, R. N., Chemical Process Industries, McGraw-Hill, N. Y., 1967.
5. Gould, R. F., Adv. in Chem. Series, 95 (1969).
6. Siu, R. G. H., Microbial Decomposition of Cellulose, Reinhold Publications, N. Y., 1951.
7. Norkrans, B., Adv. in Appl. Microbiol., 9, 91 (1967).
8. Reese, E. T., R. G. H. Siu, H. S. Levinson, J. Bacteriol. 59, 485 (1950).

ACKNOWLEDGMENTS

The author gratefully acknowledges the assistance of numerous people for the success of this investigation. Professor C. R. Wilke, author's research director, is to be thanked for his guidance, suggestions and infinite patience. Professor R. Emerson of the Botany Department helped the author in the initial part of this study with helpful suggestions. Dr. Mary Mandels of Army Natick Laboratory, in Massachusetts is to be thanked for readily providing the mutant strains utilized. In addition, Mr. Lynn Williams and Mr. Richard Ige are to be thanked for stimulating discussions on various aspects of this research. Ms. Myra Baker painstakingly typed the first draft of the thesis.

This work was performed under the auspices of the United States Atomic Energy Commission.

1. INTRODUCTION

1.1. Background

Although the history of human effort contains numerous incidents of mankind's failure to live within physical limits, it is success in overcoming these limits that forms the basis of survival of the human species on this planet. Over the past two hundred years human beings have compiled an impressive record of pushing back the apparent limits to economic growth by a series of breathtaking scientific and technological breakthroughs. The major tool in this endeavor has been the mastery of a vast, inexhaustible energy source, namely the fossil fuel reserve. However in recent years one sad fact has become more and more apparent--that the century old Malthusian principle of the impossibility of exponential growth to keep up with linear increase of the means of subsistence is still all too real. The problem, however, is more acute than this. Even if the rate of growth is slowed down appreciably as suggested by several scientists in recent years, the most notable being the systems report recently published by a research group at M.I.T. (1), the question of energy crisis in the immediate future is all too real. The fossil fuel reserve, from the global point of view, is obviously not inexhaustible and the general opinion in this area at the present time (2) seems to indicate that the present reserve is sufficient to last only till the middle of the 21st century. Unfortunately the above estimation does not take into account

the geopolitical situation properly. Any serious hostility between major oil producing countries and the rest of the world would significantly curtail the time span mentioned above.

There is little doubt that nuclear fission as well as fusion will be the prime energy source of the future. But applications have to extend beyond just the generation of electricity for these processes to be successful. With expected hydro-electric and geothermal energy sources having marginal values, nuclear power is indeed regarded as the panacea of future energy problems. However, nearly all proposals utilizing nuclear power are geared towards generation of electricity. Only 20% of present and anticipated energy consumption is in the form of electrical power, the remaining 80% as heat. It is towards this latter fraction that various efforts are at present being undertaken to manufacture a cheap source of chemical fuel. The major chemical fuel source towards which most research work has recently been done is electrolytic hydrogen. Unlike fossil fuels, hydrogen would not be a source material, but rather an energy carrier with a great deal of flexibility. The problem of pollution from burning of fuel is minimal in this context because hydrogen combustion is basically pollution free. Interest in hydrogen as a fuel has been world wide and Dr. Cesare Marchetti of Ispra Research Establishment (Italy) summarizes the future for hydrogen as following:

"Practically all the energy needed for an advanced society can be supplied in the form of electricity and hydrogen delivered through pipelines."

Another important source of energy for the future towards which the present investigation is aimed is the chemical energy stored in cellulose by photosynthesis from the sun.

1.2. Rationale for the Present Investigation

On the land area of the earth about 1.6×10^{10} tons of carbon are fixed every year by photosynthesis out of which about half appears in the form of cellulose. Hydrolysis of one pound of cellulose theoretically yields 1.1 lb glucose, which is theoretically equivalent to 0.56 lb of ethyl alcohol. This can be used as liquid fuel or the hydrolysis products (mainly glucose) can be converted to methane which can be a useful source of gaseous fuel.

Most early efforts geared towards hydrolysis of wood products (cellulose) to sugars employed acid hydrolysis. The most notable process in this context being the Bergius process in the '30's (3) using hydrochloric acid. The acid processes did not prove economically feasible because of acid losses, costly materials of construction and accompanying corrosion. In recent years cellulose degradation has been investigated by various workers through enzymatic means (4) (5) (6), the hydrolysis products being a mixture of simple reducing sugars. In terms of available energy, expressed either as the heat of combustion of cellulose or of the glucose or alcohol theoretically obtainable from it, a pound of cellulose is equivalent to 0.35 lb of gasoline (7200 BTU). In actual conversion of cellulosic materials to glucose as presented in this dissertation a net energy equivalence of 0.2 lb gasoline

per lb of cellulose seems a conservative estimate after allowance for processing inefficiencies. Noting the previous figure of 8 billion tons of cellulose fixed per year through photosynthesis all over the earth, this gives an equivalence of 12 billion tons of gasoline per year. The sheer magnitude of this potential source dictates the necessity towards improvement of the scientific and technological capabilities for cellulose utilization. The present investigation is an effort in that direction. Mention should be made in this context of an even larger quantity of carbon fixed in the oceans which has not been included in the above estimation of the potential reserve considering current technology and economic factors.

In the North American continent certain cellulosic materials are available for economic processing at this time. Two hundred ninety ninety million tons per year of residential, institutional and commercial solid wastes (7) containing approximately fifty percent paper and other cellulosic materials are produced in the United States. In addition about sixty million tons of bagasse (9) are available. These altogether contain about one hundred and twenty million tons of cellulose equivalent to one hundred and thirty million tons of glucose or sixty-six million tons of alcohol together with sixty-four million tons of carbon dioxide via fermentation. Energy equivalence of these wastes is equal to about a fifth of current U.S. gasoline consumption (10). Furthermore 2.3 billion tons per year of agricultural wastes in the U.S., having a very high cellulose content, increase the above supply significantly. Cellulose farming in this context might be

considered as a suitable supply; certain grasses, such as Savannah species (almost pure cellulose), are known to produce as much as 7.5 tons of cellulose per acre per year.

In spite of these various sources of available cellulose a major industrial alcohol fermentation process can only be successful if the reducing sugars are available at a sufficiently low price. Based on a detailed economic analysis prepared by the U. S. Dept. of Agriculture (11) it can be concluded that for fermentation to be competitive with petrochemical synthesis from ethylene the maximum allowable price for reducing sugars has to be about 4 cents per pound. This dissertation shows the practicality of producing reducing sugars (80% fermentable by yeasts) at about 1.0 cents per pound without any cost assigned to the waste cellulose itself.

If the current market price of \$23.00 per ton for waste newspaper is taken into account the cost of reducing sugars would be increased by 2.07 cents per pound to about 3.07 cents per pound. Based on these costs of reducing sugars it would seem possible to produce anhydrous alcohol in the cost range of 30-41 cents per gallon (cost of waste cellulose not included) depending upon available credit for by-product carbon dioxide. These values compare quite favorably with the current market price of 61 cents per gallon for alcohol. Also an additional benefit would be freeing of 6×10^5 tons per year of hydrocarbon as ethylene.

Alcohol-gasoline or alcohol-water mixtures have been found to be adequate as motor fuels in Western Europe (12). In terms of heat of combustion, one gallon of gasoline (as n-octane) is equivalent

to 1.4 gallon of anhydrous alcohol. The above cost figures of alcohol from cellulose should be compared with an equivalent cost of 42-57 cents per gallon of gasoline. Obviously this figure compares unfavorably with refinery price of gasoline at 14 cents per gallon. However, if the alcohol could be used in blends with water the fuel cost could become competitive. Improvements in fermentation technology could very well reduce these costs further. Also the economic balance in the long range would probably shift. A Wall Street Journal (March 15, 1973) article projects possible price for gasoline above \$1.00 within the next five to ten years. Stringent pollution control standards for hydrocarbon fuels could also become a dominant consideration in the near future.

Considering all these factors it makes eminent sense to try to develop the technology of conversion of cellulose to liquid fuels. This dissertation investigates the first half of this problem, economic conversion of cellulosic wastes to reducing sugars.

Literature cited in Chapter 1

- 1) Meadows, D. N., D. L. Meadows, J. Randers, and W. W. Behrens, "The Limit of Growth," Potomac Assoc. Book, Washington, D. C., 1972.
- 2) Chemistry and Engineering News, June 26, 1972, p. 14.
- 3) Bergius, F., Ind. Eng. Chem., 29, 247 (1973).
- 4) Gould, R. F., Adv. in Chem. Series, 95, (1969).
- 5) Siu, R. G. H., Microbial Decomposition of Cellulose, Reinhold Publications, New York (1951).
- 6) Norkans, B., Adv. in Appl. Microbiol., 9, 91 (1967).
- 7) First Annual Report of the Council on Environmental Quality, U. S. Congress, 1970.
- 8) Wiley, A. O., Ind. Eng. Chem., 47, 1397 (1955).
- 9) Chemical Week, 109(13), 21 (1970).
- 10) Shreeve, R. N., Chemical Process Industries, McGraw-Hill, N. Y. (1967).
- 11) U. S. Department of Agriculture, Miscellaneous Publications, No. 327, 1938.
- 12) Underkofler, L. A., and R. J. Hickey, Industrial Fermentations, p. 10, Chemical Publications Co., N. Y. (1954).

2. CELLULASES AND THEIR APPLICATIONS

2.1. Structural and Morphological Characteristics of Cellulose

The Cellulose molecule is a high molecular weight polymer of β - 1, 4-linked D-glucose residues. The chemical structure is as follows:

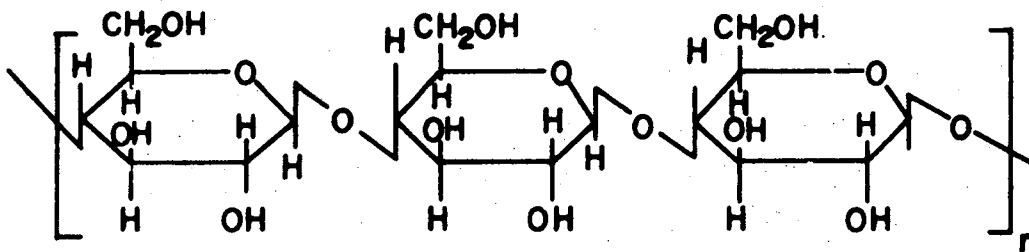

Degree of polymerization varies widely depending upon its origin. For chemical pulp and filter paper the degree of polymerization generally varies between 500 and 1000 whereas in wood cellulose it is about 8000-10,000. For cotton yarn similar values reported are as high as 15,000 (1).

For native cellulose different morphological assemblies have been proposed in literature. The generally accepted theory however is that native cellulose is basically composed of microfibrils of width 100 Å or less (2). Thicker fibrils and layers and walls of crossing fibrillar units all contain microfibrils of well defined thickness and

indefinite length. The native microfibrils exist as bundles of lamellae containing an indefinite number of units. There are ordered (crystalline) and less ordered (amorphous) regions of this bundle, the molecules of one region grading gradually into the other. A recent concept (3) shows the microfibril to be about $50 \times 100 \text{ \AA}$ in cross section consisting of a highly ordered crystalline core arranged in a rectangular array. This region is surrounded by a paracrystalline sheath which is mainly cellulose in cotton. In wood this region contains also hemicellulose and lignin. The crystalline core may or may not be continuous. A related concept (4) suggests that a number of elementary fibrils containing 15 to 40 cellulose molecules and of 33 \AA width make up to form a microfibril. The association according to this model is less well ordered at certain points of the microfibril giving rise to amorphous regions. Another recent model (5), however, suggests an entirely new idea. According to this model cellulose molecules exist in a folded chain lattice formed as a ribbon which in turns is wound in a tight helix. A serious objection to this model is that it does not corroborate X-ray diffraction and infrared absorption work showing a preferred orientation of the (101) lattice plane.

2.2. Degradation of Insoluble Cellulose

In general, the more ordered the substrate structure the more difficult it is for enzyme degradation to take place. Regenerated cellulose always presents higher number of active sites for the enzyme reaction compared to native cellulose such as cotton. If a cellulase

molecule is assumed to be spheroidal, an approximate diameter of 40 Å for molecular weight of 60,000 may be a reasonable estimation. Since cotton fiber amorphous regions consist of micelles of 600 Å length and 50 Å in width it becomes apparent that only a limited number of enzyme molecules become accessible to the substrate even if the enzyme is in excess. An assumption of cylindrical shape of the enzyme molecule, as proposed by Whitaker (6)(7) of about 200 Å × 33 Å, makes its movement in the intermicellar spaces more restricted.

A term designated as 'swelling factor' has been in use since the papers of Marsh (8)(9) to denote the absorbability of eighteen per cent sodium hydroxide on cotton fibers. This swelling was attributed to partial damage of the primary and secondary wall of the fiber. Electromicroscopic observation by Norkrans (10) substantiated these findings later. Subsequent work by Nisizawa et al., (11) also corroborated these findings. Swelling factor responses were accompanied by decrease in degree of polymerization (d.p.) in these findings indicating equivalence to hydrolytic action by the enzyme itself. A swelling maximum was obtained in prolonged treatment with the enzyme. Nisizawa proposed the existence of 'semicrystalline' regions from these experiments which cannot absorb alkali in ordinary state but upon treatment with enzyme change to an amorphous state which can readily absorb alkali.

There is, however, a striking difference between acid hydrolysis and enzyme hydrolysis as far as mechanism of hydrolytic action is concerned. Work done by Reese et al. (12) can be mentioned in

this context. On treatment with a 1.8% cellulase solution the d. p. of the pulp decreased from 900 to 800 corresponding to 40% hydrolysis. In contrast, acid hydrolysis with 4N hydrochloric acid resulted in a decrease of d. p. from 900 to 200 corresponding to 15% hydrolysis. The morphological characteristics of the pulp were considerably changed upon acid treatment resulting in much shorter length and width of fibers. But similar periods of enzyme treatment resulted in essentially the same length and width of the pulp fiber.

2.3. C₁ - C_x Components of Cellulase and their Mode of Action

The mechanism of degradation of crystalline cellulose to simple sugars by enzymatic means has been the object of intense study for the last 25 years. Reese, Siu and Levinson (13) first suggested the conversion of native cellulose to soluble sugars based on a 2-step process. The C₁ component of the enzyme was postulated to first disaggregate the cellulose chain prior to its solubilization. The subsequent hydrolytic action at the β -1, 4 linked glucosyl bonds of the solubilized chains was attributed to the C_x component of the enzyme. According to these workers microorganisms which grow only on soluble cellulose, such as carboxymethyl cellulose, synthesize only C_x components. However, other microorganisms capable of growing on highly ordered forms of cellulose produce both C₁ and C_x. The latter group of microorganisms includes Trichoderma viride, Trichoderma koningii, Fusarium solani, Penicillium funiculosum, etc. Native cellulose on exposure to cellulase from this group of microorganisms shows extensive change in physical properties: increased capacity of alkali absorption

and moisture absorption, transverse cracking, loss of tensile strength, etc., before producing any measurable amount of reducing sugars. These occur almost simultaneously. Work of Halliwell (14) and Marsh (15) and Marsh (16) should be mentioned in this context. Working with culture filtrates of the genus *Trichoderma*, Halliwell (14) found various degraded but insoluble fragments from cotton during initial periods of enzymatic hydrolysis. These were then converted to reducing sugars by different cellulases. Marsh (15) also found little production of soluble material during initial fragmentation of fibers. Similar results recently reported by Rautela and King (17) and by Liu and King (18) substantiate these findings. Electron microscopic observations indicated that the initial fragmentation of fibers on exposure to cellulase (from *T. viride*) was initiated by the formation of longitudinal fissures.

Mandels and Reese (19) subsequently purified the cellulase from culture filtrates of *T. viride* by passage through DEAE-dextran columns. Cotton silver and CM-cellulose were utilized as substrates for measurement of C_1 and C_x activities respectively. Separated fractions from the column chromatography experiments showed that the C_x fraction hydrolyzes CM-cellulose but without any activity towards cotton. These observations substantiated the two-step C_1 - C_x theory to a great extent.

Numerous reports dealing with fractionation of true cellulolytic microorganisms' culture filtrates have appeared in literature since then. In general, all these reports have indicated that cellulases from these microorganisms are multi-component enzyme systems. Substantial evidence for the existence of a C_1 component has been found.

However, controversy still exists as to the specificity of various C_1 components and specially the original two-step sequential C_1-C_x mechanism has been questioned increasingly in recent years. There are confusing and contradictory claims in abundance in the literature on this matter. A couple of general ideas and observations, however, are prevalent in all these findings and these are reviewed briefly in the following paragraphs.

Selby and Maitland (20)(21) reported the isolation of a C_1 component from cultures of T. viride. A CM-cellulase fraction and a cellobiase fraction were also isolated. The C_1 fraction by itself did not support any cellulose degradation but in the presence of the C_x fraction it was fully active. These three fractions were purified by passage through Sephadex columns followed by ion-exchange chromatography. The summary of their findings are shown in the following table.

Table 1. Activities of Cellulase Components of T. viride Alone and in Combination.

Component	% Recovery of Activity		
	Cotton	CM-Cellulose	Cellobiose
C_1	1.2	0	0
CM-Cellulase	<1	96	0
Cellobiase	<1	0	96
CM-Cellulase+ Cellobiase	2	96	96
C_1 + CM-Cellulase	35	96	7
C_1 + Cellobiase	27	7	96
C_1 + CM-Cellulase+ Cellobiase	101	96	96

The important findings of these observations were the striking synergistic action of C_1 and C_x . Two possible hypotheses were proposed: that C_1 makes cotton fiber more susceptible for C_x action or that C_1 is inhibited by the products of its own reaction unless these are removed by C_x action. The second possibility is probably more valid because of the additional synergistic action of the cellobiase fraction. Also these workers found that when the action of C_1 alone takes place with simultaneous dialysis against water its activity is increased by 50%. All of these, of course, substantiate the original C_1 - C_x theory, that the cotton fibers are attacked successively by C_1 , C_x and cellobiase or β -glucosidase to form glucose.

Evidence to the contrary has appeared in the literature in recent years. Those reports all agree that cellulase from true cellulolytic microorganisms is indeed a multicomponent system as did the previous workers. What is questioned is the assertion that the C_1 -component of the enzyme attacks the cellulose fiber as the first step. Wood (22) and Wood and McCrae (23) have purified C_1 -component in the cellulase complex of Trichoderma koningii and Fusarium solani and gel filtration, ion exchange chromatography and electrofocusing. The C_1 -component thus purified still possessed a limited ability to produce reducing sugars from a solution of CM-cellulose but by itself could not attack highly ordered or crystalline cellulose. The C_1 -component when acting alone attacked oligosaccharides (cellotetrose and cellohexose) to the 2-step C_1 - C_x hypothesis and cellobiose was virtually the sole product of these reactions. Similar results were

also reported by Pettersson et al. (24) working with purified C_1 component from T. viride cellulase.

Nisizawa et al. (25) similarly could not remove CM-cellulase activity from purified C_1 component of T. viride after repeated purified C_1 fraction by itself attacked amorphous and soluble cellulose by endwise (exo) mechanism with cellobiose as the sole product. The purified CM-cellulase fraction on the other hand showed more random (endo) mechanism towards cello-oligosaccharides and CM-cellulose. Most interestingly the purified CM-cellulase fraction decreased the degree of polymerization (d.p.) of cotton at a much faster rate than purified C_1 fraction as shown in Fig. 1. Similar results are reported by these workers from culture filtrates of Irpex lacteus. All these results combine to postulate the alternative hypothesis. It is the C_x component which delivers the initial attack on cellulose chain by random action producing fragments of lower molecular weight which can then be acted upon by C_1 component by an endwise (exo) mechanism producing cellobiose residues.

2.4. Degradation of soluble cellulose

Degradation of soluble cellulose (CM-cellulose, carboxyethyl (CE)-cellulose, hydroxymethyl (HM)-cellulose, hydroxyethyl (HE)-cellulose, etc.) by cellulase is carried out either by a random mechanism (enzymes called endoglucanases) or by removal of cellobiose units from the end of the chain (enzymes called exoglucanases). Various reports from Reese (26), Kooiman et al. (27), Hash et al. (28) suggest endoglucanases to be the major constituent of all

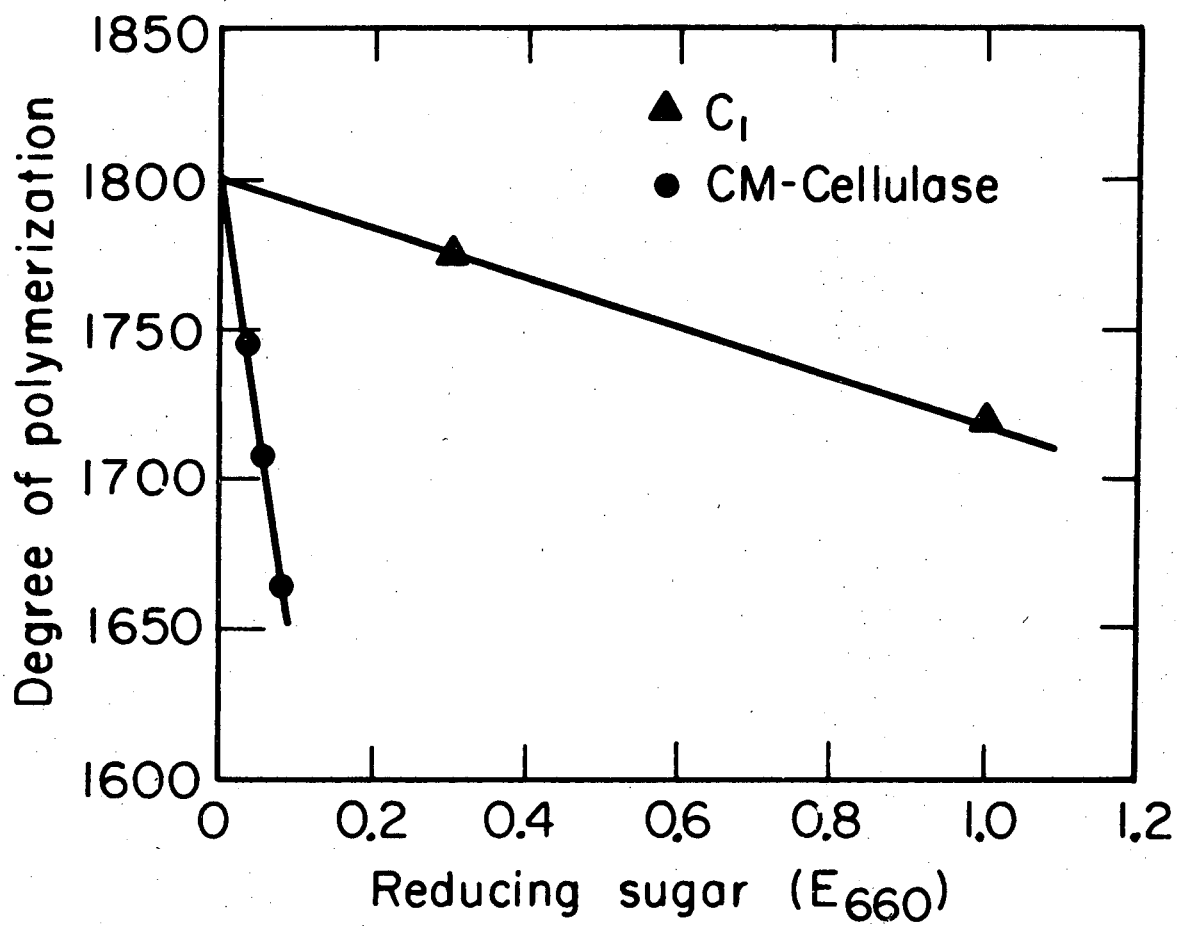

XBL7310-4232

Fig. 1. Decrease in d.p. of cotton and simultaneous production of reducing sugar (2).

cellulases. However, other reports from Storvick et al. (29), King (30), Li et al. (31) demonstrate the presence of exoglucanases as well. The relative amounts of these two fractions were very much dependent upon the microorganism studied and to a certain degree upon the substrate as well. The pioneering work on the actions of these glucanases on various oligosaccharides, however, was done by Whitaker (32) in 1956. Cellobiose, cellotriose, cellotetrose, and cellopento-
se were utilized as substrates for hydrolysis by Myrothecium verrucaria cellulase and first order velocity constants and activation energies were measured. As the chain length increased from two to five the rate constant progressively increased and an overall increase by a factor 450 from cellobiose to cellopento-
se was noticed. The activation energy, however, remained constant at 12,000 calories/mole for all these observations. The obvious interpretation of this observation of increase in rate constant with chain length was in terms of classical collision theory determined solely by steric factor. Whitaker (32) repeated these experiments with the substrates modified by reduction to a corresponding sorbityl derivative. Compared to unreduced substrates reduced substrates showed lower reaction rate constants but the general trend of increasing rate constants with increasing chain length was maintained even for these modified substrates. Effect of partial denaturation of the enzyme by heat was also studied in these experiments. Loss of activity of this denatured enzyme was different towards different substrates, the loss being greater for the smaller oligosaccharides. This observation too was interpreted as due to steric factors by

Whitaker.

Li et al. (31) reported characteristic hydrolysis of B-1, 4 oligosaccharides with T. viride cellulase. A highly purified fraction of endoglucanase was obtained from this enzyme and its relative frequency of attack on the four glucosidic linkage of reduced cellopento-
se studied. The third linkage from the non-reducing end showed the highest frequency indicating that the cellopento-
se was most easily split into cel-
lulose and cellobiose. This situation was quite similar to the hydrolysis of amorphous cellulose by the same enzyme preparation. Similar work by Storvick et al. (29) and Cole et al. (33) investigating action of cellulase components from Cellvibrio gilvus on cellopento-
se and cellobiose indicated the preferential cleavage of the second and third glucosidic linkage from the non-reducing end. Similar results were also reported by Toda et al. (34) and Yamane et al. (35).

2.5. Kinetics of enzymatic breakdown of cellulose

Most of the kinetic analysis of enzymatic degradation of cellulose has been empirical. Substrate specificities of various cellulase components are quite different and synergistic action of these components is necessary for any appreciable breakdown of insoluble cellulose. Consequently no sound theoretical basis for interpretation of data has been proposed, the mechanism of degradation varying a great deal from one source of enzyme to another, also from one type of substrate from another. One of the oldest empirical equations in this area is the so-called 'Schutz's equation' first demonstrated by Karrer et al. (36) (37) for reaction of crude snail juice cellulase on regenerated cotton

cellulose. According to this equation

$$v \propto t^{1/2}$$

where

v → velocity of the hydrolytic reaction

t → time

An extension of this concept was tested by Miyamoka et al. (38) with cellulase preparations from various fungi acting on colloidal hydrocellulose. The empirical equation proposed to fit the obtained data was of the form

$$x = k t^m e^n$$

where

x → percentage hydrolysis

e → amount of cellulase present

t → reaction time

k → empirical velocity constant

m, n → characteristic exponents of the cellulase enzyme

Data presented for cellulose from Aspergillus niger showed the cellulase activity to be proportional to $e^{1/3}$. Also the ratio $(x/t^{1/3})$ was nearly constant for the entire reaction time of about 72 hours. Similar results were presented with cellulase preparation from Irpex lacteus, the ratio $x/t^{1/2}$ for these observations was nearly constant. Theoretical interpretation of these observations was not presented by the authors due to the difficulties stated in the previous paragraph.

Amount of enzyme adsorbed on the surface of the solid substrate is an important parameter in this context. McLaren (39) proposed that the reaction velocity is proportional to the surface adsorbed enzyme

according to Freundlich's equation

$$E_a/A_s = K(E)^n$$

where

E_a → moles of enzyme adsorbed on surface area A_s

E → amount of total enzyme

K → proportional coefficient

n → exponent (< 1), characteristic of the enzyme

Also, for insoluble substrate and soluble enzyme in aqueous medium.

Initial rate of hydrolysis = constant × (concentration of bound enzyme on substrate surface).

The value of exponent n for Myrothecium verrucaria cellulase preparation was calculated by the same author to be 0.66 on precipitated cellulose and 0.77 on swollen linters. King (30) reported digestion of crystalline cellulose by the C_1 component isolated from T. viride culture to follow Schultz's equation. For cases where rate of hydrolysis was dependent upon surface area of the insoluble substrate an alternative form was proposed as follows

$$V = V_o - kt^3$$

where

V_o is the initial particle volume

V is the particle volume after reaction time t

k is a proportionality constant

A recent report by Amemura et al. (40)(41), however, showed enzymatic hydrolysis by cellulase (obtained from Penicillium variable) on insoluble substrate to follow classical Michaelis-Menten type relation within a limited range of reaction. Lineweaver-Burk plot at the

earlier stages of hydrolysis produced a straight line with a K_m (Michaelis-Menten constant) value of 3.57 gm/l. Degradation of insoluble substrate according to these authors corroborated the concepts proposed by Reese et al. (12); the amorphous regions were attacked first resulting in enrichment of the crystalline region. The latter regions then loosened their peripheral parts turning to fringe micelles of the amorphous state. This sequence kept continuing, the schematic illustration being as follows:

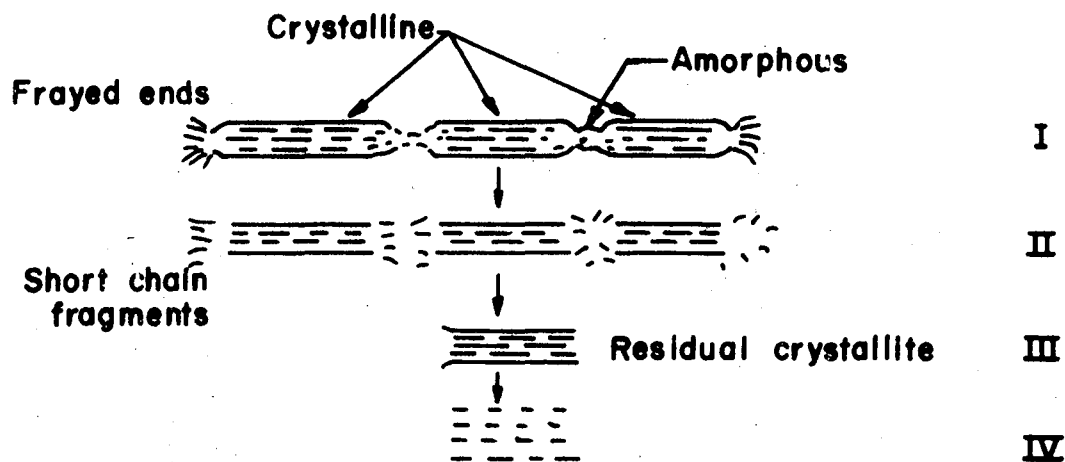

2.6. Kinetics of enzymatic breakdown of oligosaccharides

At a sufficiently low enzyme concentration the rate of hydrolysis is expressed by the traditional second-order kinetics

$$-\frac{ds}{dt} = K [E] [S]$$

where

[E], [S] are concentrations of enzyme and substrate respectively

K is the second order velocity constant.

For a sufficiently high enzyme concentration the above equation reduces to the first order form

$$-\frac{ds}{dt} = K' [S]$$

where

K' is the pseudo-first order velocity constant.

Integrating the above equation

$$K' = \frac{1}{t} \ln \frac{[S_0]}{[S]}$$

where

S₀ is the initial substrate concentration

S is the substrate concentration at time t

Whitaker (42) working with a purified cellulase preparation from Myrothecium verrucaria reported the following pseudo-first order rate constants for the oligosaccharides. Protein concentration in these experiments was reported to be 20 µg/ml.

Substrate	K' (10^{-5} seconds)
Cellobiose	1.2
Cellotriose	16
Cellotetrose	83
Cellopentoase	500

For cellotriose, cellotetrose, and cellopentoase a maximum of initial reaction velocity was found at substrate concentrations 10^{-2} , 5×10^{-3} and 2×10^{-3} molal respectively, above which substrate inhibition was noticed. Nisizawa et al. (43) observed similar results with fractionated cellulase components from culture filtrates of Irpex lacteus by starch-zone electrophoresis. Maximum rates of hydrolysis in these experiments were obtained at substrate concentrations of 10^{-4} , 10^{-3} , and 10^{-1} molar concentrations for cellopentoase, cellotetrose, and cellotriose respectively. K_m values of exo and endoglucanases from T. viride have been estimated Li et al. (31). The results are shown in Table 2. K_m values for exoglucanases were much smaller than those of

Table 2. K_m (Michaelis Constant) values for exo and endoglucanases of T. viride acting on various β , 1-4 Oligosaccharides.

Substrate	K_m (Molar)	
	Endoglucanase	Exoglucanase
Cellobiose	$190 \times 10^{-4}^*$	$220 \times 10^{-5}^*$
Cellotriose	31×10^{-4}	$18 \times 10^{-5}^*$
Cellotetrose	28×10^{-4}	$6.5 \times 10^{-5}^*$
Cellopentoase	7.0×10^{-4}	6.0×10^{-5}
Cellohexose	$1.0 \times 10^{-4}^*$	$16 \times 10^{-5}^*$

* Lineweaver-Burk plot showed apparent substrate inhibition at concentrations greater than 0.05 M.

endoglucanases for all the oligosaccharides tested. This suggested that exoglucanases are more similar in nature to β -glucosidases than endoglucanases. For both exo and endoglucanases affinity of the enzyme to the substrate increased roughly parallel to the increase in the chain length. For both reduced and non-reduced oligosaccharides K_m values were of the same order but the V_{max} (maximum velocity of enzymatic degradation) values were decreased for reduced oligosaccharides. This indicated that the reducing groups do not affect the enzyme-substrate complex but affect the rate of substrate breakdown.

Literature cited in Chapter 2.

- 1) Goring, D. A. I. and T. E. Timell, *Tappi*, 45, 454 (1962).
- 2) Ranby, B., S. A. Rydholm, 'Polymer Processes, High Polymers', Interscience, N. Y. Publisher, 10, IX, 351 (1956).
- 3) Mühlethaler, K., *Ann. Rev. Plant Phys.*, 18, 1 (1967).
- 4) Hess, K., H. Mahl, and E. Gütter, *Kolloid Z.*, 155, 1 (1957).
- 5) Manly, R. St. J., *Nature*, 204, 1155 (1964).
- 6) Whitaker, D. R., *Arch. Biochem Biophys.*, 53, 439 (1954).
- 7) Whitaker, D. R., *Can. J. Biochem. Physiol.*, 34, 488 (1956).
- 8) Marsh, P. B., G. V. Merola, and M. S. Simpson, *Text. Res. J.*, 23, 831 (1953).
- 9) Marsh, P. B., K. Bollenbacker, M. L. Butler, and L. R. Guthrie, *Text. Res. J.*, 23, 878 (1953).
- 10) Norkrans, B., *Ann. Review Phytopath.*, 1, 325 (1963).
- 11) Nisizawa, T., H. Suzuki, and K. Nisizawa, *J. Ferment. Tech.*, 44, 659 (1966).
- 12) Reese, E. T., L. Segal, and V. W. Tripp, *Text. Res. J.*, 27, 626 (1957).
- 13) Reese, E. T., R. G. H. Siu, and H. S. Levinson, *J. Bacteriol.*, 59, 485 (1950).
- 14) Halliwell, G., *Biochem. J.*, 95, 270 (1965).
- 15) Marsh, P. B., *Text. Res. J.*, 27, 913 (1957).
- 16) Marsh, C. A., *Biochem. Biophys. Acta*, 122, 367 (1966).

- 17) Rautela, G. S., and K. W. King, Arch. Biochem. Biophys., 123, 589 (1968).
- 18) Liu, T. H., and K. W. King, Arch. Biochem. Biophys., 120, 426 (1967).
- 19) Mandels, M. and E. T. Reese, Develop. Indus. Microbiol., 5, (1964).
- 20) Selby, K., and C. C. Maitland, Arch. Biochem. Biophys., 118, 254 (1967).
- 21) Selby, K., and C. C. Maitland, Biochem. J., 104, 716 (1967)
- 22) Wood, T. M. Ferment. Technol. Today, Soc. Ferment. Technol., Japan, 711 (1972).
- 23) Wood, T. M., S. I. McCrae, Biochem. J., 128, 1183 (1972).
- 24) Petterson, L. G., Axio-Fredriksson, U. Berghen, L. E. R., Ferment. Technol. Today, Soc. Ferment. Technol., Japan, 727 (1972).
- 25) Nisizawa, K., Y. Tomita, T. Kanda, H. Suzuki, and K. Wakabayashi, Ferment. Technol. Today, Soc. Ferment. Technol., Japan, 719 (1972).
- 26) Reese, E. T., Appl. Microbiol. 4, 39 (1956).
- 27) Kooiman, P., P. A. Roelofsen, and S. Sweeris, Enzymologia, 16, 237 (1953).
- 28) Hash, J. H., K. W. King, J. Biol. Chem., 232, 381 (1958).
- 29) Storvick, W. O., F. E. Cole, and K. W. King, Biochem., 2, 1106 (1963).
- 30) King, K. W., J. Ferment. Tech., 43, 79 (1965).

- 31) Li, L. H., R. M. Flora, and K. W. King, Arch. Biochem. Biophys. 111, 439 (1965).
- 32) Whitaker, D. R., Can. J. Biochem. Physiol., 34, 102 (1956).
- 33) Cole, F. E., and K. W. King, Biochim. Biophys. Acta, 81, 122 (1964).
- 34) Toda, S., H. Suzuki, and K. Nisizawa, J. Ferment. Tech., 46, 711 (1968).
- 35) Yamane, K., H. Suzuki, and K. Nisizawa, J. Biochem. (Tokyo) 67, 19 (1970).
- 36) Karrer, P., P. Schubert, and W. Wehrli, Helv. Chim. Acta, 8, 797 (1925).
- 37) Karrer, P., and P. Schubert, Helv. Chim. Acta, 9, 893 (1926).
- 38) Miyamoto, S., and K. Nisizawa, J. Veterinary Soc. Army, Japan, 396, 778 (1942).
- 39) McLaren, A. D., Enzymologia, 26, 237 (1963).
- 40) Amemura, A., and G. Terui, J. Ferment. Tech., 43, 275 (1965).
- 41) Amemura, A., and G. Terui, J. Ferment. Tech., 43, 281 (1965).
- 42) Whitaker, D. R., Marine Boring and Fouling Organisms, p. 301, Univ. of Washington Press, Seattle (1959).
- 43) Nisizawa, K., Y. Hashimoto, and Y. Shibata, Adv. in Enzymic Hydrolysis of Cellulose and Related Materials, p. 171, Pergamon Press, N. Y. (1963).

3. EXPERIMENTAL PROCEDURES

3.1. Assay Procedures

3.1.1. Enzyme Activity Assay

Cellulase is a complex enzyme showing various types of activities with respect to different kinds of substrates. There are many assay methods reported in literature for assaying cellulase and Halliwell's account (1) summarizes the major efforts in this area. For quantitative work all assay methods are based on relatively short hydrolysis periods of the enzyme on the accessible portion of the cellulose substrate. For the present work assay procedures suggested by Mandels and Weber (2) were adopted. Cellulase activities were measured by interacting a given substrate with the enzyme and measuring the amount of reducing sugar produced in a given time by dinitrosalicylic acid test.

C₁-Cotton - This test measures C₁ activity. Fifty mg of absorbent cotton was added to 1 ml appropriately diluted enzyme and 1 ml of 0.5 M sodium citrate buffer at pH 4.8. Reaction was carried out at 50°C for 24 hours and amount of reducing sugar produced measured by dinitrosalicylic acid test.

Filter Paper Activity - This test measures combined C₁-C_x activity. Fifty mg (1 × 6 cm) of Whatman filter paper No. 1 was added to a mixture of 1 ml of appropriately diluted enzyme and 1 ml of 0.05 M sodium citrate buffer at pH 4.8. Reaction was carried out at 50°C for

1 hour and reducing sugar concentration determined by dinitrosalicylic acid test.

C_x Activity - This test determines β (1-4) glucanase activity. To 0.5 ml of 1.0% carboxymethylcellulose (CMC, 50T, Hercules Powder Co.) in 0.05 M sodium citrate buffer (pH 4.8) 0.5 ml of appropriately diluted enzyme was added and reaction carried out at 50°C for 1/2 hour followed by reducing sugar determination by dinitrosalicylic acid test.

Filter paper activity and C₁ activity in these tests were expressed as mg of reducing sugar produced by the undiluted enzyme sample. The number of C_x units equaled the inverse of dilution re-measures the combined C₁-C_x activity this was the major enzyme activity test performed throughout the present investigation. The time for the test was short and the substrate easily duplicated under laboratory conditions and hence the entire test was highly reproducible.

3.1.2. Cellulose Assay

In the presence of fungal biomass a chemical method for determination of cellulose content of the sample was adopted. The method utilized was one originally suggested by Viles and Silverman (3) and modified by Upedegraff (4). This is a simple, rapid, colorimetric method for concentration range of 0.05-0.45 mg/ml cellulose

with a sensitivity in the range of 5 $\mu\text{g/ml}$.*

For samples of ball milled newspaper, lignin, hemi-cellulose and xylosans were removed by extraction with acetic acid/nitric acid reagent (150 ml 80% acetic acid and 15 ml concentrated nitric acid). The leftover cellulose was dissolved in 10 ml 67% H_2SO_4 . Appropriate dilution (so that resultant concentration is in the range 0.05-0.5 mg/ml) was made with distilled water. 1 ml of this dilution was added to 4.0 ml of distilled water in a screw cap tube and put in an ice bath to cool. 10 ml of cold anthrone reagent (0.2 gm anthrone in 100 ml concentrated H_2SO_4 , prepared and chilled 2 hours before use) was added to the above, mixed well on a Vortex mixer and put back in the ice bath. The sample tube was then placed in a boiling water bath for 16 minutes, cooled in ice bath for 3 minutes, and kept at room temperature for 10 minutes. Absorbance was then measured in the DU-2 spectrophotometer at 620 mu against an appropriate blank treated in the identical way.

The standard curve prepared with Solka Floc (purified Spruce Wood, Brown Company) dehydrated in the drying oven is shown in Figure 2.

3.1.3. Reducing Sugar

Reducing sugar was estimated using dinitrosalicylic acid method

* The test is made by rapidly adding a solution of anthrone (0.2% in concentrated sulfuric acid) to a sulfuric acid (67%) digest of cellulose sample in presence of water. Under controlled conditions the intensity of the bluish green color is proportional to the cellulose content.

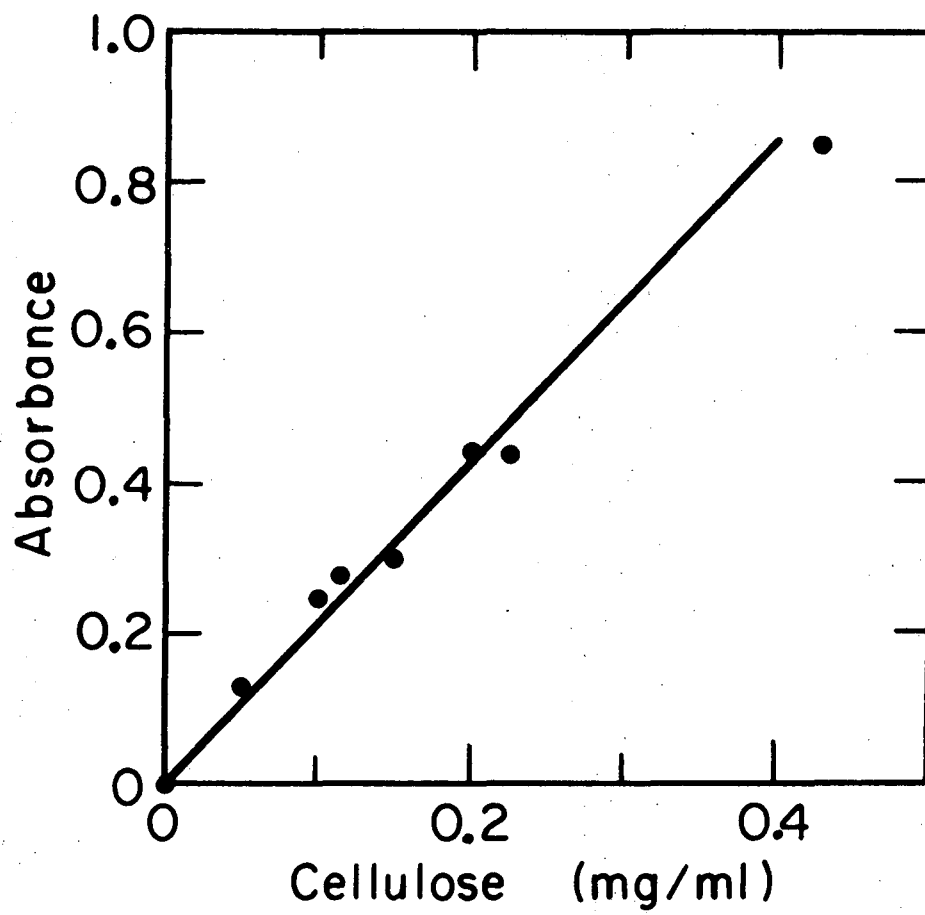

XBL 7310-4231

Fig. 2. Standard curve for cellulose.

(5). 3 ml of DNS reagent was added to 1 ml of sample in a test tube, mixed thoroughly in a Vortex mixer and placed in a boiling water bath for exactly 5 minutes. The tube was removed from the water bath, cooled to room temperature and then diluted with distilled water to a final volume of 25 ml. The contents were well mixed by inverting the tube 3-4 times and absorbance measured with a Beckman DU-2 spectrophotometer at 600 m μ against an appropriate DNS reagent and distilled water blank. The standard curve prepared with anhydrous dextrose (Mallinckrodt chemicals) is shown in Figure 3.

3.1.4. Protein Assay

Protein assay was one of the major parameters measured throughout the present investigation. Primarily this was done to measure the amount of free enzyme in solution. Samples were centrifuged at high speed (10,000 rpm at 0° C followed by decantation of the supernatant which was assayed for its protein content. Also the estimation of fungal biomass in presence of insoluble inducer (cellulose) was made by assaying the protein content of the precipitate following centrifugation of the sample and washing the precipitate with citrate buffer.

Generally the practice over a number of years has been to use the standard Lowry method (6) for determination of protein in biological samples. However, results of studies performed with this method have shown high variability and low reproducibility. Since for engineering analysis the latter factor is of considerable importance a modified microbiuret method proposed by Koch and Putnam (7) was

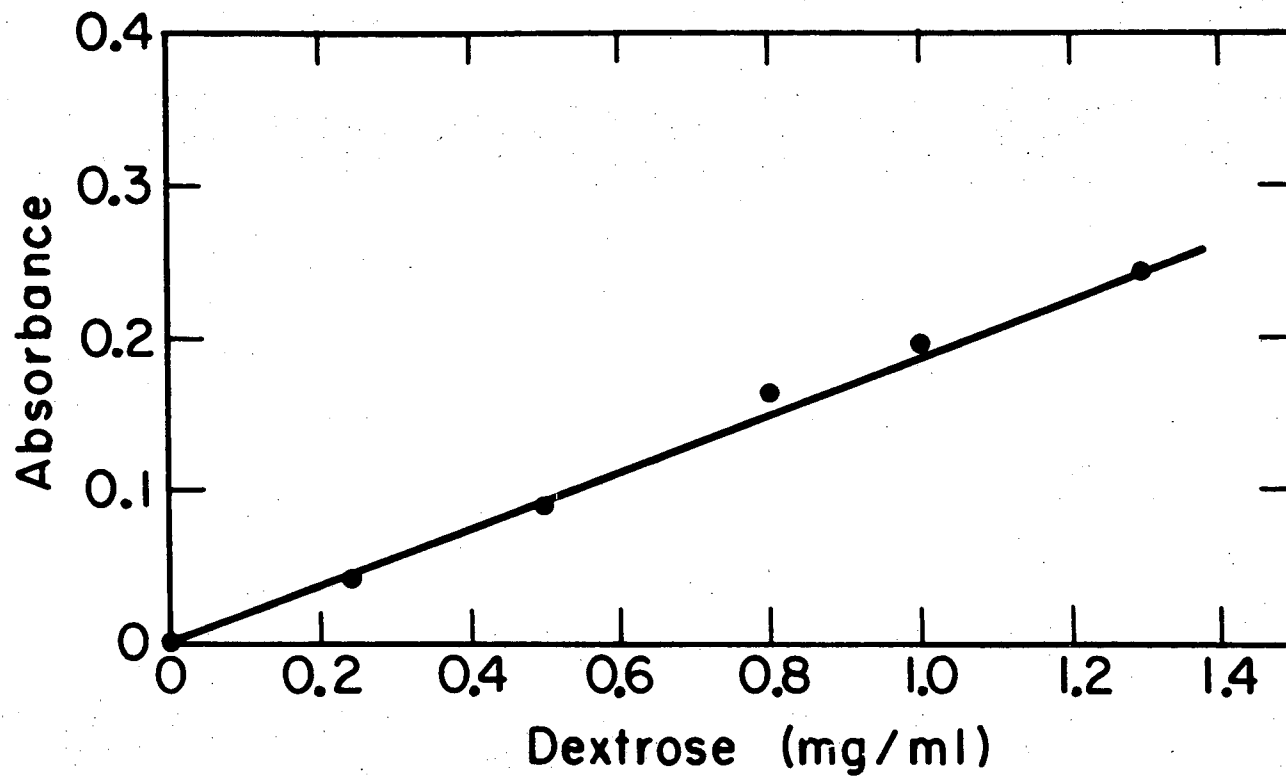

XBL 7310-4230

Fig. 3. Standard curve for reducing sugar.

used for protein assay in our studies. Though the sensitivity of this assay technique was about one-fifth of the usual Lowry method it showed more consistency. Also the sensitivity of the assay technique ($\sim 28 \mu\text{g}$ protein/ml) was more than adequate for our purpose.

The standard curve (Fig. 4) was prepared with Bovine Serum Albumin as standard. For enzyme assay 1 ml of clear solution was added to 4.0 ml of copper containing reagent and mixed thoroughly with the Vortex mixer and then the absorbance is read at $330 \text{ m}\mu$ after 0.5 hr at room temperature. All samples were run in duplicate with a corresponding blank of 1 ml of citrate buffer (pH 4.8). For fungal biomass determination a 10 ml homogeneous sample was centrifuged at 10,000 rpm and the precipitate after washing twice with citrate buffer was added to 1 ml of 4.6 N sodium hydroxide. The contents were mixed well and placed in boiling water bath for 5 minutes. The tube was cooled down, 4.0 ml of copper containing biuret reagent added to it and absorbance measured at $330 \text{ m}\mu$ after 0.5 hr at room temperature. To correct for light scattering an identical duplicate sample was run which was reacted to 4.0 ml of copper-less biuret reagent after sodium hydroxide treatment and its absorbance at $330 \text{ m}\mu$ was directly subtracted from the previous sample to get the effective absorbance reading.

To correlate protein contents of the fungus to the total biomass, batch growth of the fungus was carried out with soluble substrate (1% dextrose) and a calibration curve was prepared between dry wt. of fungus and protein content (Fig. 5). The least square line between the experimental points indicates 31.3% of the fungal dry weight to be protein.

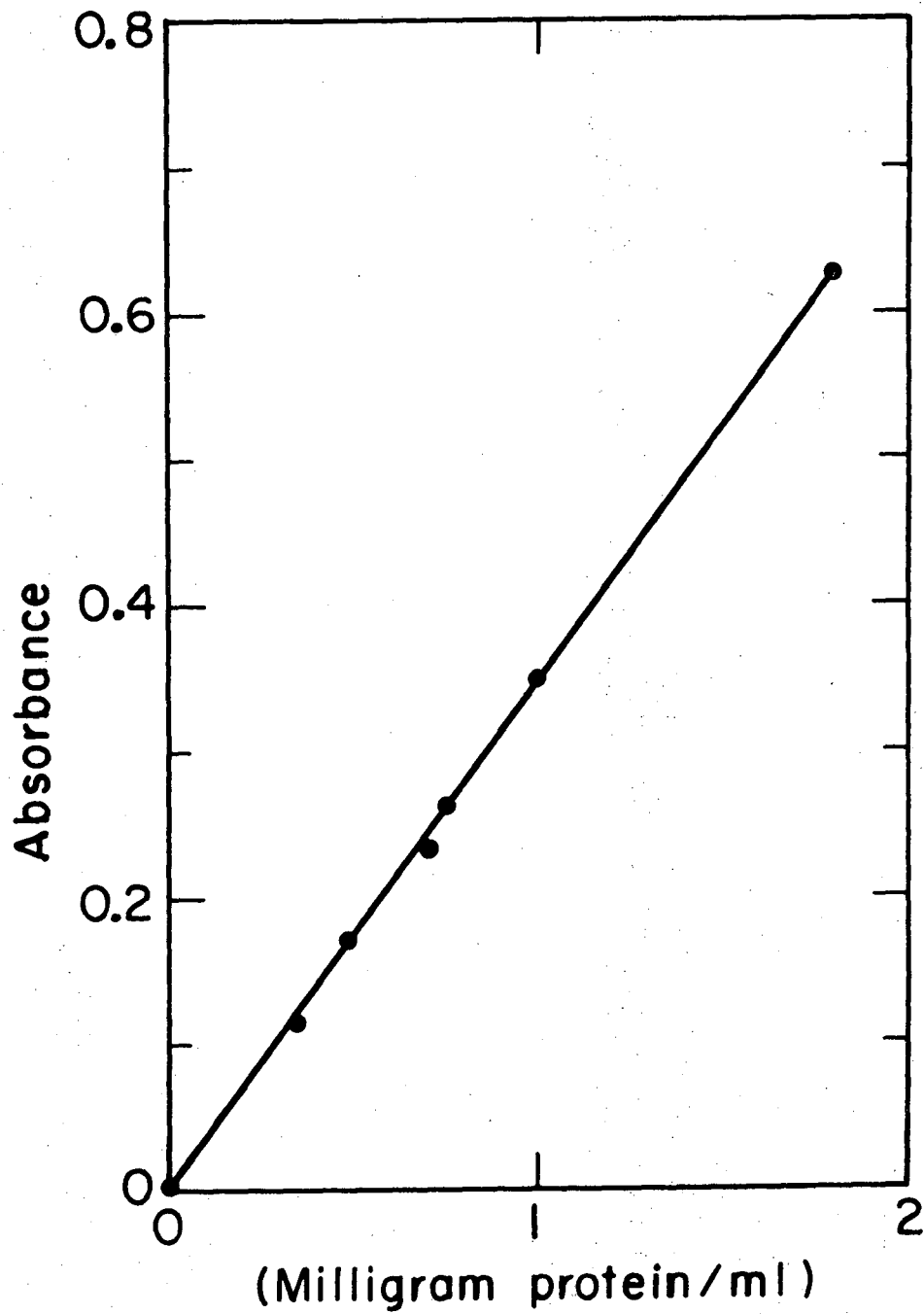

XBL7310-4229

Fig. 4. Standard curve for biuret protein.

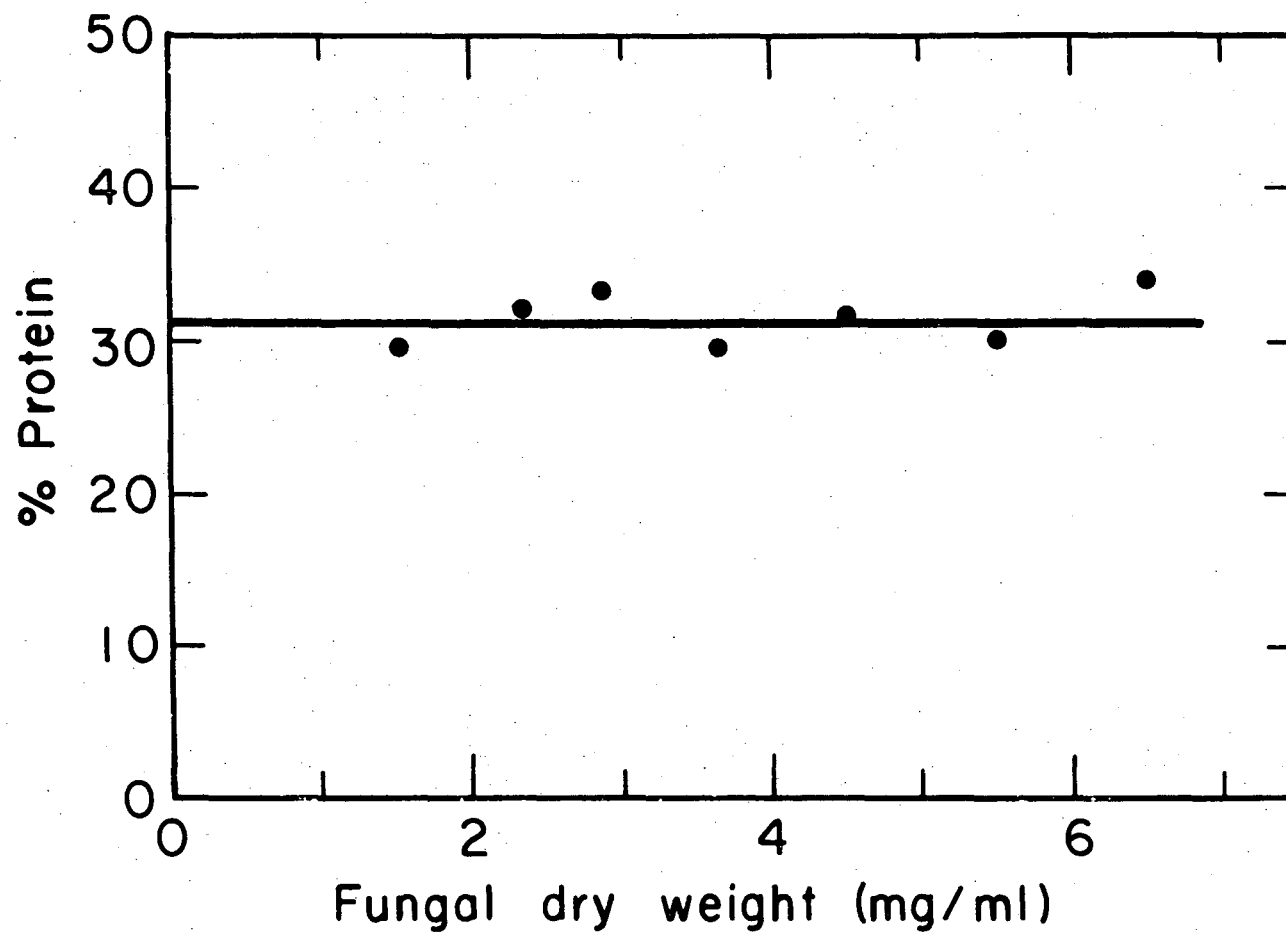

XBL7310-4228

Fig. 5. Dry weight of biomass against protein content.

3.1.5. Q_{O₂} Measurement

During growth of the fungus T. viride QM 9414 on soluble sugars the specific respiration rate Q_{O_2} in $\frac{\text{millimoles of } O_2}{(\text{gm dry wt})(\text{hr})}$ was estimated according to the method suggested by Bandyopadhyay et al. (8). The method consisted of dynamic measurement of dissolved oxygen concentration with a fast response, sterilizable, dissolved oxygen probe during a brief interruption of the aeration of the fermenting system.

For a typical experiment batch growth of the fungus was studied in a Miniferm with a total liquid volume of 800 ml. The probe attached to one of the ports on the head plate was sterilized in place. At various times during the fermentation the incoming air was turned off and the probe response was followed on an appropriate high speed voltage recorder. Immediately after the air turn off nitrogen was sparged over the surface of the liquid (Rate 1 V. V. M.) to minimize surface aeration. After the hold up bubbles of air escaped within the first couple of seconds

$$\text{Change of dissolved oxygen concentration} = - \frac{dc}{dt} = Q_{O_2} X$$

where X, the biomass per unit volume of the fermentor fluid was assumed constant during this degassing experiment.* The slope of the concentration against time straight line response on the voltage recorder was noted which remained constant during the first 5 minutes

*There was no measurable time lag to the probe response.

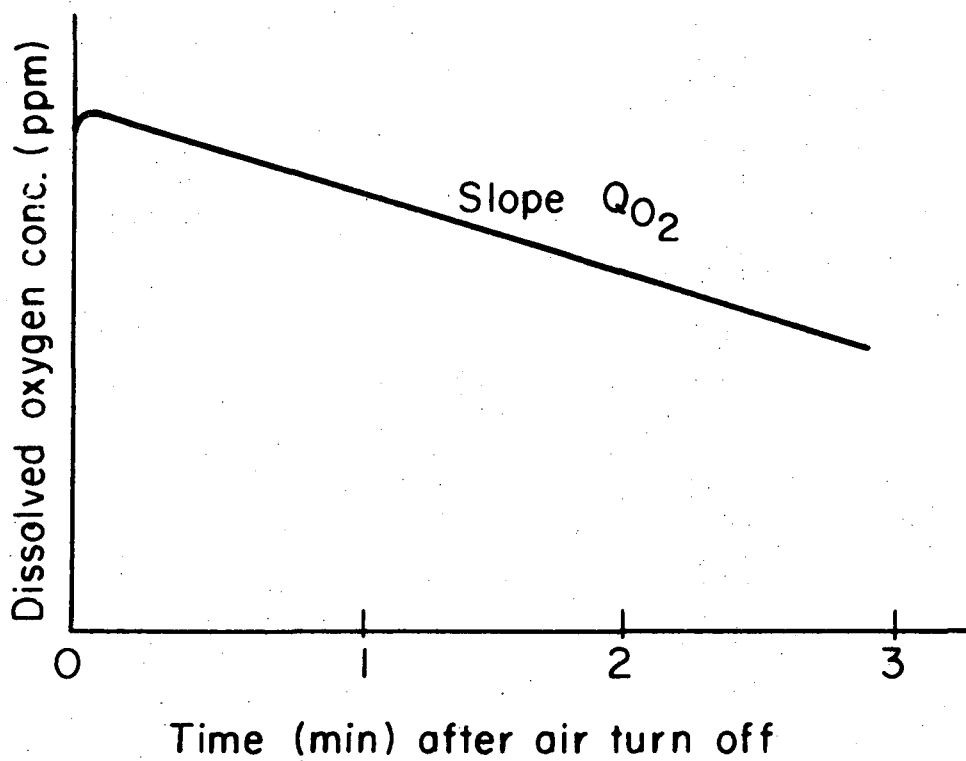
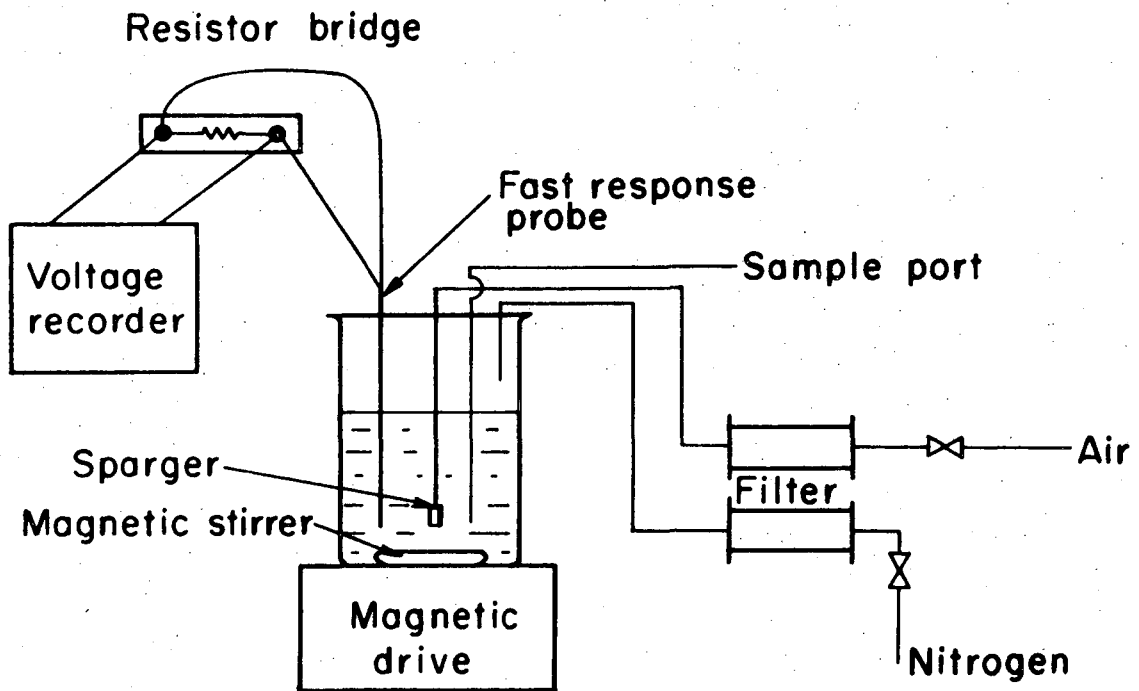

XBL7310-4227

Fig. 6. Q_{O_2} measurement setup.

after air turnoff Fig. (6). Appropriate homogeneous sample of the liquid was drawn for biomass determination and the air flow was turned on again with simultaneous shut off of the nitrogen stream.

The total degassing time never exceeded 5 minutes and during this time the constant biomass assumption for the slow growing fungus introduced negligible error in the estimation of Q_{O_2} . These measurements were repeated over several biomass concentrations during the batch growth.

3.2. Enzyme Production

New Brunswick Scientific Corporation 14 liter culture vessels were used for batch production of the enzyme and the growth of the fungus. The vessel, made of pyrex glass, was connected to a stainless steel head plate through a flange and six wing nuts, with a rubber O-ring seal between the glass jar and the head plate. The head plate contained necessary ports for various inlets, outlets and control probes for the operation of the unit. An impeller shaft extended through a graphite bearing seal (to prevent contamination) on the center of the head plate and was connected to a 1/3 HP General Electric Statorol motor (variable speed) by a universal joint coupling. Two 4-blade, 4-5/8 inch diameter turbine impellers were fitted on the shaft; one directly above the air sparger and the other at the liquid level of the vessel. The former helped dispersion of the incoming bubbles whereas the latter facilitated foam break up. The head plate was fitted with 4 internal baffles which helped promote turbulence during agitation. These baffles were

hollow in nature; one of them served as the air line leading towards the sparger; two others were utilized for circulation of water for achieving constant temperature.

Constant temperature was maintained by circulating water from an outside water bath by a centrifugal pump. The immersion heater in this water bath (500-watt, knife blade type) was connected to a YSI proportional temperature controller (Yellowsprings Instrument Co., Ohio) which in turn was connected to the precision thermistor probe (Cole Parmer Company, Chicago, Illinois) inside the thermal well (positioned inside the vessel through the head plate). Close temperature regulation within $\pm 0.1^\circ\text{C}$ was easily maintained.

The measuring and the silver chloride reference pH electrode were obtained from Leeds Northrup Co., Pennsylvania. Temperature range for their operation was listed between 20 and 60°C with provisions for steam sterilization at 130°C for maximum two hours at a time. The pH electrodes were inserted into stainless steel sleeves which screwed into the fermentor head. The signals from the electrodes went to a Beckman Model 900 pH controller-analyzer (on-off type) coupled to a New Brunswick PA-6 peristaltic pump which added 5(N) hydrochloric acid or 5(N) sodium hydroxide to maintain constant pH operation.

Aeration was provided by feeding the building compressed air at 40 psig into a pressure regulator where the pressure was reduced to about 5 psig. The air then passed through a rotameter and 1/4 inch nylon tubing to a glass wool filter (to remove contamination air borne microbes) and then through a humidifier to the single hole sparger

directly below the bottom impeller. Oxygen concentration in the liquid was monitored by a New Brunswick membrane bound dissolved oxygen probe. The current from the leads of this probe passed through an appropriate resistor bridge and the voltage drop was measured with a Leeds Northrup Speedomax type G recorder. The measured voltage drop was proportional to the dissolved oxygen concentration in the system. Provision was also made for control of foam, which was a common problem during the operation of the fermentor unit. A foam sensing probe was inserted inside the culture vessel which sent a signal to a foam control unit (New Brunswick Scientific Co.) when excessive foam developed. This activated the operation of a peristaltic pump which fed an antifoam agent (Antifoam 60, silicone emulsion, General Electric) until the foam was reduced or eliminated.

A three unit system of culture vessels was designed and assembled for the present investigation. An individual unit with its various control attachments is shown in the accompanying schematic diagram, Figure 7. Before starting a typical batch (working volume between 5l and 10l) the culture vessel was dissociated from the drive motor by loosening the universal joint coupling, the required medium components added and mixed with a portable Lightening Mixer (Mixing Equipment Company, Rochester, New York) in distilled water, and the stainless steel head plate replaced on top and tightened with the wing nuts through the rubber O-ring seal. The entire vessel with its accompanying sterilizable surgical tubings was then placed in a New Brunswick vertical autoclave and sterilized at 15 psig and 121° C. The steam in the autoclave was generated by an electrical heater and

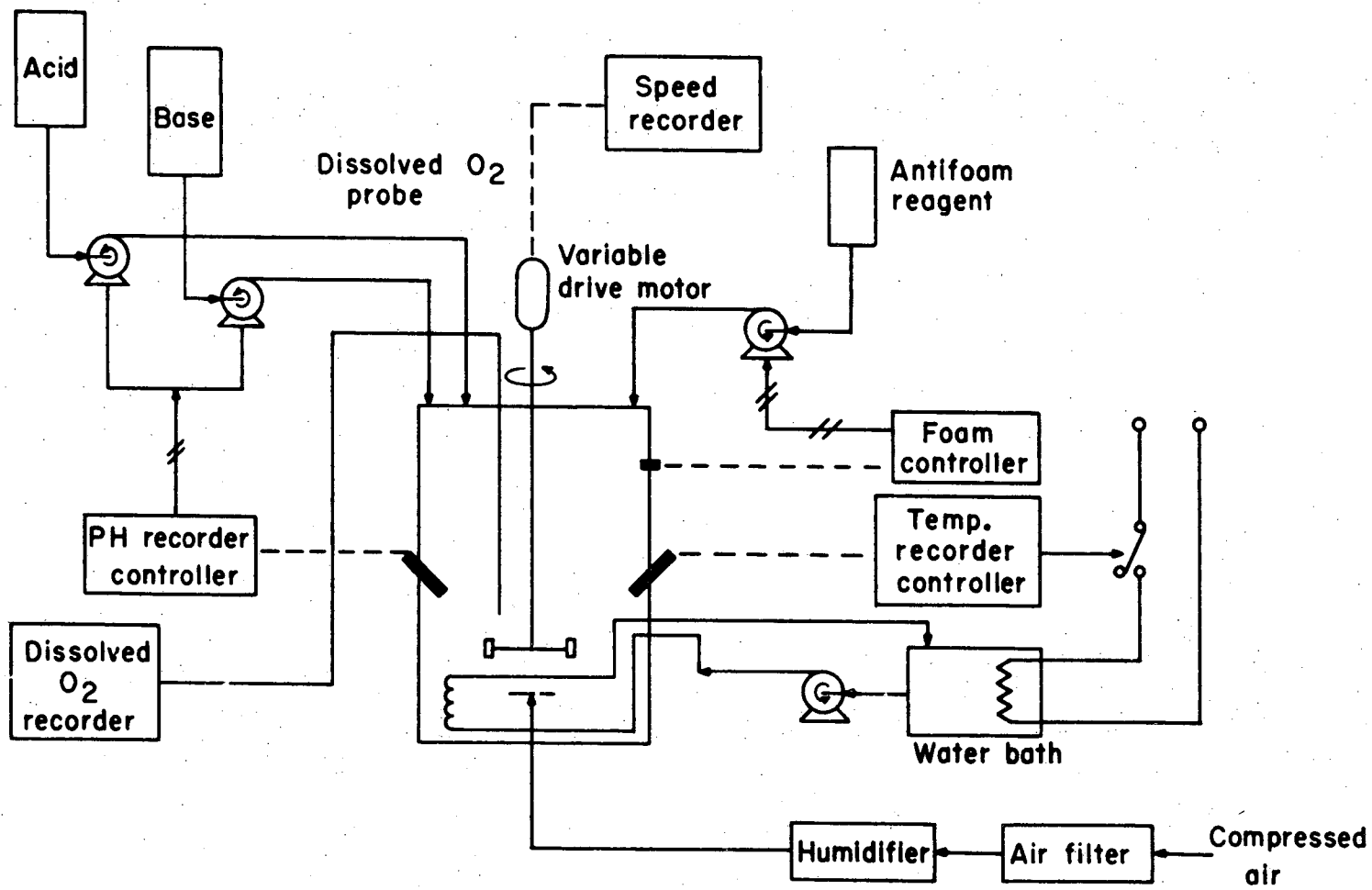

XBL7310 - 4174

Fig. 7. Schematic arrangement of 14 liter New Brunswick fermenter and its controls.

a typical holding time for a 10 l batch at 121°C was 1/2 hour. The fermentor was then slowly cooled down to room temperature, removed from the autoclave and attached to the proper assembly position. The acid/base reservoir and the air filter and humidifier were also sterilized in a similar manner but separately. These were then joined to the main fermentor unit through ground glass joints with utmost care for preserving sterility of the entire system. The fermentor was then ready for the start of a run.

Inoculum was prepared in 250 ml Erlenmeyer flasks with working volume between 100 and 150 ml. Incubation was carried out in a New Brunswick AQUATHERM water bath shaker and the contents were transferred to the fermentor aseptically through the 3/4" screw cap inoculation port on the fermentor head. A special sampling device was utilized to collect samples at regular intervals. In this device a length of silicone rubber tubing was attached from the stainless steel sampling line mounted in the fermentor head to a rubber stopper inserted in a sterile 125 ml Erlenmeyer flask. A syringe with a two-way valve was used to evacuate stagnant liquid in the line; air was pumped through an air filter and flowed through the sampling line forcing out the stagnant liquid. The same syringe was used to collect samples; the pressure in the collection flask was reduced by pumping action of the syringe attached to an air filter. The drop in pressure forced the culture liquid to flow from the vessel to the sampling flask. The flask was then removed and replaced aseptically by another sterile flask. After taking a sample microscopic examination was always made to check for possible contamination.

For Continuous Stirred Tank Reactor (C. S. T. R.) operations 5 gallon glass carboys were used for feed tanks. Feed tank medium was prepared just as that of the fermentor medium, the total volume of liquid in the feed tank being kept between 15 and 20 liters. Feed liquid was delivered to the fermentor vessel by a variable speed Masterflex pump (Cole Parmer, Chicago, Illinois). A Masterflex Tachometer was directly attached to the pump head, giving direct reading of both the pump speed and percent of full flow. Manufacturer's guaranteed accuracy within 2% of full scale reading facilitated constant feed rate to the fermentor for a prolonged period (2 to 3 days corresponding to a volume throughout equivalent to 2 to 3 times that of the volume of the fermentor liquid) of time till steady state operation was attained. Constant volume of the fermentor liquid was maintained by a variable length outlet pipe. For a given fermentor volume it was positioned just above the liquid level; the outlet end of the pipe was attached to a glass carboy through a piece of vacuum tubing. The vent hole from this receptacle was connected to the house vacuum (17" of Hg) by another piece of vacuum tubing. Whenever the liquid level in the fermentor went above the pre-set level the pressure difference forced the excess liquid out into the product receptacle. This design of delivery outlet from the fermentor was exceptionally stable over a prolonged period of time and in general proved to be superior to the traditional scheme of a siphone-breaker. Specially with 2-stage operation with insoluble cellulose the latter scheme inevitably resulted in clogging of delivery outlet within a period of 24 hours operation.

For 2 stage C. S. T. R. operation pure spruce wood cellulose Solka Flocc (Brown Company, Providence, R. I.) was fed continuously into the second stage by a low rate volumetric disc feeder, BIF Omega model 22-01 (General Signal Corp., Providence, R. I.). The feeder transferred solids to the fermentor by gravity, aided by agitators, to the feed disc. The disc had an accurately machined groove which filled with material as it rotated beneath the hopper. Groove filler springs rotated with the disc to break up small lumps and assured complete filling of the groove. A stationary plow, shaped to fit the groove and mounted at the feeder discharge, removed all material from the groove as the disc revolved. The variable speed transmission, operated by an outside handwheel, could operate the system over a range of 0 - 100% maximum capacity. For the unit assembled 100% capacity corresponded to 80 cubic inches per hour. The transmission of the factor operated in an oil bath to minimize friction. A sifter assembly was driven from the constant speed shaft of the transmission and oscillated at a constant rate. Small agglomerates of Solka Flocc from the rotating disc fell into the sifter and were immediately broken up by the motion of the screen. A precision made steel funnel was fitted snugly on the discharge port and the other end of the funnel was connected to a transparent vinyl chloride tubing which transplanted the solids into the fermentor. To prevent build up of solids inside the tubing resulting from the air pressure inside the fermentor sterile air at 5 psig was utilized to blow the solid particle down the tubing straight into the fermentor. At the same time the

piece of tubing was constantly shaken mechanically to facilitate easy discharge of the solids.

A schematic diagram of the 2-stage C. S. T. R. operation is shown in Fig. 8.

3.3. Ultrafiltration

3.3.1. Background

Low pressure membrane ultrafiltration has emerged as an important biological separation/purification device within the last decade. It is basically a process of selective molecular separation utilizing microporous membranes which would pass solvent and low molecular weight solutes, retaining solutes and colloidal matter of larger molecular dimensions. This separation is effected without phase change and hence avoids the deleterious effects associated with phase change, specially important for biological fluids. Like a reverse osmosis membrane ultrafiltration is driven by hydraulic pressure but unlike the former ultrafiltration does not require very high operating pressures. The term reverse osmosis is usually reserved for separation of low molecular weight solutes. The osmotic pressure for these is usually quite high (500-2000 psi) and hence the driving pressure for separation has to exceed these values in order to operate a viable process. Macromolecules on the other hand (separation being effected by ultrafiltration) have very low osmotic pressure and hence operating pressure range for ultrafiltration is usually within the range of 5 to 100 psi.

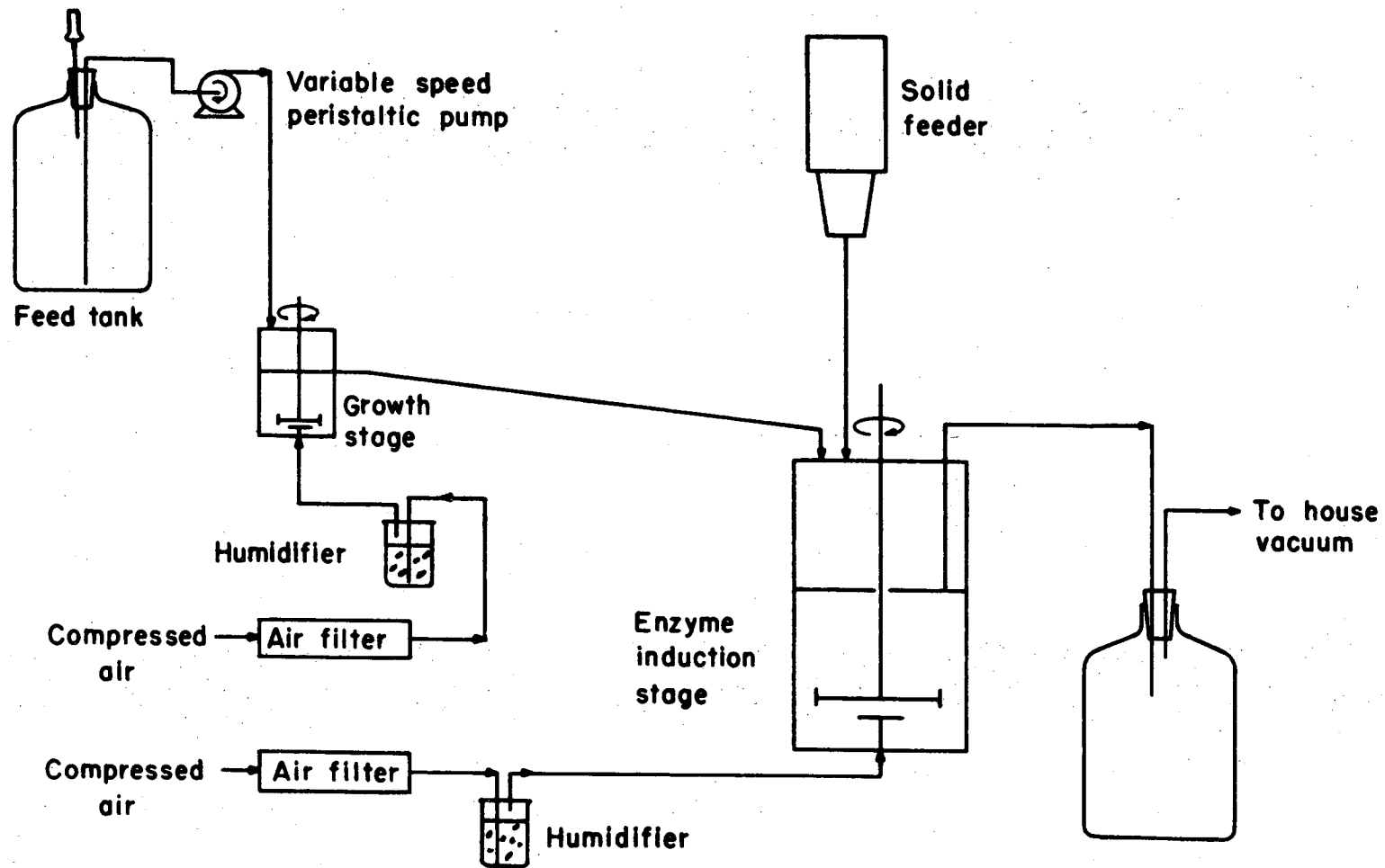

-47-

XBL 7310 - 4173

Fig. 8. Schematic arrangement for C.S.T.R. operation of the 2 stage system. Individual control units not shown.

The emergence of ultrafiltration as a practical process depended a great deal upon preparation of anisotropic membranes (9) in the late fifties, which resulted in preparation of membranes of very thin layer (0.1-0.5 μ) supported by relatively thicker porous support structure (2-10 mm). Various methods were developed for preparation of anisotropic membranes from different synthetic polymers and a survey of readily available ultrafiltration membranes was prepared by Michaels (10). Various commercial concerns manufacture ultrafiltration membranes at the present time--Amicon Corporation, Abcor Incorporated, and General Electric are the major concerns in this area. In general these membranes are utilized in the following four general areas:

- i) Concentration: involves removal of water or solvent without phase change resulting in enrichment of macromolecular solute.
- ii) Desalting: removal of simple electrolytes, salt exchange.
- iii) Purification: removal of high or low molecular weight solutes.
- iv) Fractionation: Separation of macromolecular mixtures. In the present investigation ultrafiltration of cellulase enzyme (macromolecular mixture) was carried out in stirred cells basically for fractionation.

3.3.2. Theory

Theoretical analysis of ultrafiltration is available in literature in detail (11)(12) and only analysis relevant to the present investigation will be reviewed here.

In general, $J(\text{water flux through membrane}) = A \Delta P$. (i)

where A membrane constant (dependent upon pressure)
 ΔP hydrostatic pressure as driving force.

In presence of macromolecular solute however-equation (i) has to be rewritten as

$$J = A(\Delta P - \Delta \tau) \quad (\text{ii})$$

where $\Delta \tau =$ osmotic pressure difference across the
membrane

$$= \tau_W - \tau_P$$

W, P suffixes denoting osmotic pressures at membrane surface and permeate respectively. Osmotic pressures for biological macromolecules are usually small, specially for concentration ranges below 1%. Between 1 and 5% concentration range the osmotic pressure can be evaluated from the following equation derived by Flory (13)

$$\tau(\text{osmotic pr}) = \frac{RTC}{M} \left(1 + \frac{\Gamma}{2} C \right)^2 \quad (\text{iii})$$

where Γ second virial coefficient,
 C macromolecular concentration, and
 M macrosolute molecular weight

In actual ultrafiltration experiments however the continuous solute rejection at the membrane surface results in accumulation which increasingly prevents solvent flow through membrane. Finally the convective transport of solute toward the membrane equals the rate of back diffusive transport away from it and the solvent flux through membrane approaches zero. This phenomenon is known as concentration polarization and most ultrafiltration process equipment technology is geared to minimizing this effect. The greater the velocity of the feed solute, or the Reynold's number, the greater is the shear rate at the membrane surface resulting in lesser concentration polarization and hence higher transmembrane flux. In general an optimum shear rate is determined from power costs and membrane area cost considerations.

A model incorporating concentration polarization becomes identical to that of constant pressure filtration

$$J(\text{flux}) = \frac{\Delta P}{R_G + R_M} \quad (\text{iv})$$

where R_M → flow resistance due to membrane
 R_G → flow resistance due to deposited solute at the membrane surface.

The deposited solute layer becomes thicker until convective transport of solute (JC) towards the membrane becomes equal to the back diffusion of the solute to the bulk of the solution to give

$$JC - D \frac{dc}{dx} = 0 \quad (\text{v})$$

where D is the diffusivity of the solute
 $\frac{dc}{dx}$ is the concentration gradient of the solute with
distance x away from the membrane

Integrating equation (v)

$$J = k \log \frac{C_I}{C_b}$$

where C_I solute concentration at the interphase
 C_b bulk solute concentration
 k mass transfer coefficient dependent upon solute
diffusivity and hydrodynamic conditions.

Figure (9) gives a schematic diagram of the transport model. For stirred cell ultrafiltration Smith et al. (14) relate mass transfer coefficient k with operating conditions as

$$\frac{kb}{D} = \text{Const. } Re^m Sc^{1/3}$$

where exponent m is dependent upon system geometry

b → stirred cell radius

D → diffusivity of solute

Re, Sc → Reynold's number and Schmidt number
respectively.

Later work by Goldsmith (12) with 1% dextran solutions indicated a value of $1/3$ for exponent m .

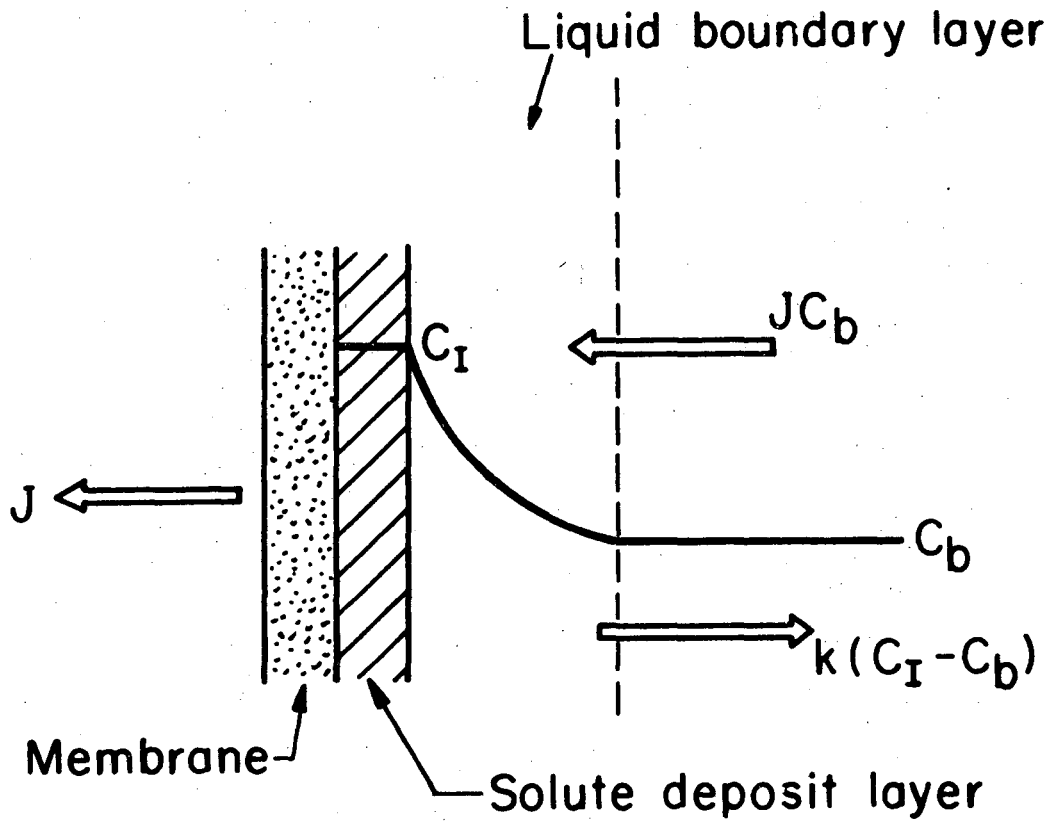

XBL7310-4226

Fig. 9. Transport model for steady state ultrafiltration.

3.3.3. Experimental Technique

Amicon Corporation (Lexington, Massachusetts) manufactured Diaflow ultrafiltration membranes of PM series were used for the present investigation. These membranes could withstand autoclaving and were chemically inert with no marked adsorption of co-ordinated ionic or inorganic solutes. Retention characteristics of these membranes (Fig. 10) determined the use of PM30 membranes; this corresponded to 90% or more retention of species of molecular weight greater than 30,000. Since the macromolecular mixture in Trichoderma viride cellulase has been reported in literature to be between molecular weight range of 12,6000-62,000 (20) the choice of separation across a molecular weight of 30,000 seemed proper for the study of two distinct fractions of the enzyme.

Amicon manufactured magnetically stirred model 202 ultrafiltration cell was utilized for this study. The membrane was held on disposable porous discs in the bottom of the cell with transparent sleeve fittings to assure leak proof operations. All material in contact with liquid inside the cell was biologically compatible nylon, teflon or other inert plastics. The cell was connected to pressure source (Nitrogen gas cylinder) through 1/4 inch O.D. plastic tubing. The maximum liquid volume inside the cell was 200 ml and the membrane diameter was 62 mm corresponding to an effective ultrafiltration area of 27.5 cm². The maximum pressure at which this system could be operated was 75 psi. For all operations magnetic stirring was provided by a standard laboratory magnetic stirrer (Lapine Scientific Co., Chicago, Ill).

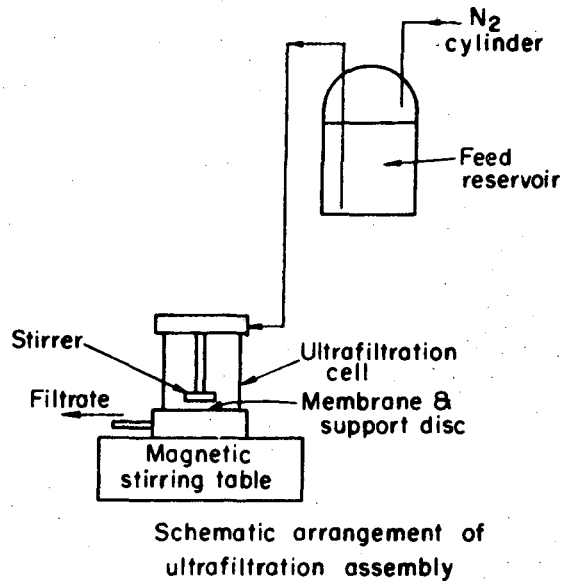
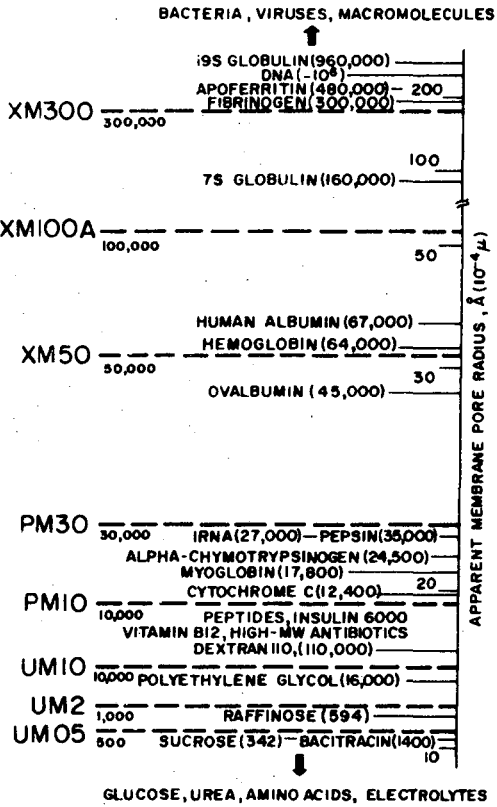

Retention characteristics of ultrafiltration membranes

XBL7310-4225

Fig. 10. Retention characteristics of amicon membranes and ultrafiltration assembly.

For liquid volume greater than 200 ml a 4 liter stainless steel pressurized reservoir (Model RS 4, Amicon Corporation) was used to hold the feed solution, the nitrogen pressure source was connected to this feed tank to maintain a constant liquid level inside the stirred ultrafiltration cell. The ultrafiltration assembly is shown schematically in Fig. 10.

3.4. Gel Filtration

3.4.1. Background

Chromatographic separation of proteins presents special problems compared to other biological compounds. Lability towards extreme pH and ionic strength, low diffusivity due to high molecular weights, polyelectrolyte nature—are the major characteristics to be taken into account in this context. Ion-exchange resins can be considered as concentrated forms of strong or weak acids or bases. Consequently the range of ion-exchangers that can be utilized to contact proteins without causing denaturation is limited. The idea of chromatographic separation of proteins based on different molecular dimensions penetrating different amounts of a suitable stationary phase evolved from these considerations. Utilization of this concept succeeded with the preparation of suitable stationary phases (gels) and this technique came to be known as Gel Filtration and became a standard technique of protein chemistry by the mid sixties.

Lathe and Ruthven (15) first reported clear description of chromatographic separation of proteins based mainly on molecular dimensions, charge effects having secondary considerations. Working with

starch columns good separation of neutral or isoelectric solutes was obtained in the molecular weight range of 60 to 1,000. These results also produced a good correlation between elution order and the molecular weights of the solutes. The method was extended for solutes of higher molecular weights (up to 60,000) by the use of swollen maize starch granules. Complications arose in fully interpreting these results due to the use of a stationary phase of natural origin; however, this work of Lathe and Ruthven (15) is the basis of all modern molecular sieve chromatography of large molecules.

Extension of this pioneering work was soon taken up by other research workers, the main thrust being preparation of suitable artificial stationary phase. The most important advance in this area was the work of Porath and Flodin (16) who reported preparation of artificially cross-linked dextrans as suitable stationary phase. The amount of cross-linking between linear glucose chains could be regulated chemically resulting in water insoluble polymers with different water regain values. These values, inversely related to degree of cross-linking, were considerably greater than that of ion-exchange resins; lowest amount of cross-linking corresponded to 20 gm water per gm of dextran.

Carefully standardized cross-linked dextrans (cross-linking agent being epichlorohydrin) are marketed under the name Sephadex by Pharmacia Fine Chemicals of Sweden. Because of the large number of hydroxyl groups in the polysaccharide chains, Sephadex is strongly hydrophilic. Various types of Sephadex possess different swelling properties. Gels in which the matrix is a minor component

are used for fractionation of high molecular weight substances, whereas denser gels are used for separation of low molecular weight compounds.

3.4.2. Theory

Theoretical basis of gel-filtration is extensively covered in literature (17, 18) and only the fundamentals pertinent to the present work will be discussed here. In general V_t (total packed volume of the column) = V_g (volume occupied by gel matrix) + V_i (volume within the gel particles or the internal volume) + V_c (volume in between the gel particles). Not all the internal volume V_i is available to solute molecules as a portion is bound to the dextran as solvent of solution. The true stationary phase volume V_s is about 80% of V_i . For aqueous solvents the internal volume

$$V_i = \frac{m}{d} \cdot Wr$$

where m is the dry weight of dextran, Wr is the water regain, d is the wet density of the swollen gel. Sephadex gels are manufactured with various standard values of d according to its grade.

The chromatographic behavior of a solute in a dextran gel system may be described by the following equation.

$$\bar{V} = V_c + a \cdot V_s$$

\bar{V} is the retention volume of the solute, a is the partition coefficient between the external and internal phases. If a solute is totally excluded

from the internal phase of the gel particle $\alpha = 0$, $\bar{V} = V_c$ and the solute appears at the outlet after passage of one column volume of solvent. At the other end of the spectrum if the solute can enter the gel phase freely, $\alpha = 1$ and $\bar{V} = V_c + V_s$. The solute for this case appears in the effluent after passage of a volume equal to the sum of column and internal volumes. For analytical purpose a separation of a mixture of proteins has to be operated in a region of hindered diffusion into the gel or between the two extreme cases mentioned above. The partition coefficient α is directly related to the molecular weight of the solute and the relationship reported by Andrews (19) between α and molecular weight of globular proteins is shown in Figure 11, using various grades of Sephadex. A gel should be chosen so that separation occurs in the linear part of the α versus molecular weight diagram. Literature report for T. viride cellulase enzyme complex (20) falls in the general range of 12,600-62,000 and consequently all gel filtration work in the present investigation was carried out with Sephadex G-75.

Various theories are available in literature to account for values of partition coefficient of a solute between the stationary and mobile phase. Flodin (21) considered the partition phenomena resulting from steric effects only, dividing the gel matrix into permitted and forbidden regions. In the permitted region the concentration of the solute is identical with that of the interstitial liquid. The larger the molecular dimension of the solute, the greater will be the proportion of the gel constituting the forbidden region. Extensions of this approach can be found in works of Porath (22) and Squire (23).

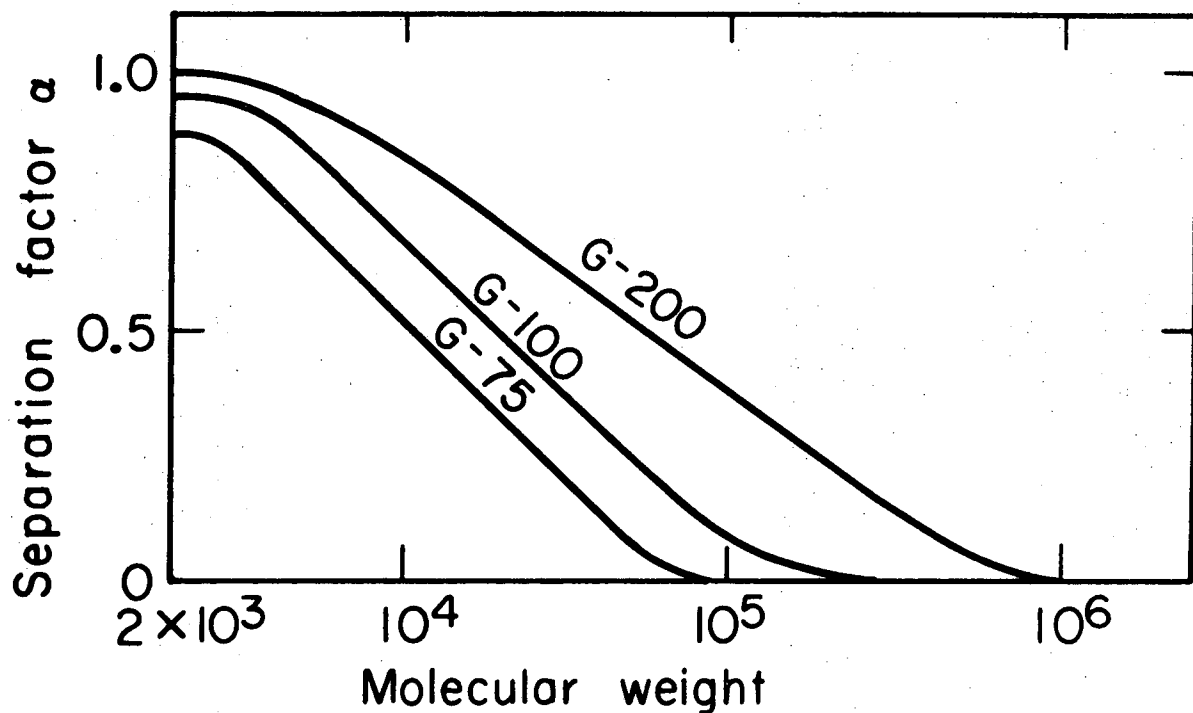

XBL7310-4223

Fig. 11. Separation factor vs molecular weight (logarithmic scale) for globular proteins on various types of sephadex gels.

This approach to partition of solute due to steric effects only does not take into account the difference of affinity of the solute to the gel phase and the solvent phase. With gels of low water region or a high content of gel matrix effects of differences in affinity are often as great as steric effects. Marsden (24) investigated these two effects and their contributions to partition coefficient for work with Sephadex G-10 and G-15.

3.4.3. Experimental Technique

Solvent used for elution was phosphate buffer, essentially the same as reported by Selby and Maitland (20), 10 millimoles of total phosphate, 100 millimole of NaCl, pH adjusted to 6.5. To obtain reasonable flow rates and satisfactory separation the G-75 gel was prepared carefully, allowed to swell in excess solvent and left to stand at room temperature for 24 hours. Antimicrobial agent Merthiolate (ethyl mercuric thiosalicylate, manufactured by Eli Lilly & Co., Indianapolis, Ind.) was added at a concentration of 0.005% to the suspension. The swollen gel was allowed to settle and excess elutant removed to obtain a fairly thick slurry. Special care had to be taken to exclude trapped air bubbles from the system. The gels then were ready to be poured into the chromatographic column.

The column used was Sephadex laboratory column type K25/100 equipped with a suitable flow adapter and sample applicator. Schematic diagram and specification of this type of column are shown in Fig. 12. The column was used for descending flow chromatography. It consisted of a precision bore (diameter 2.5 cm) borosilicate glass tube

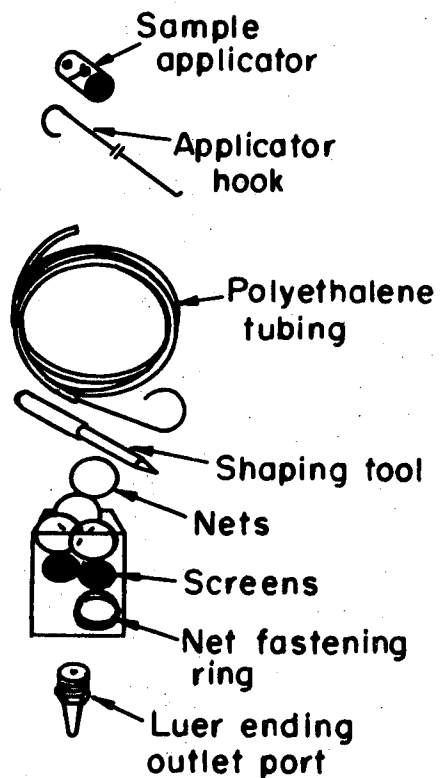
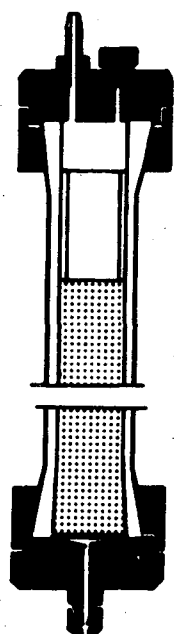

SPECIFICATION

Type	Diameter cm	Length cm	Bed volume ml	Approximate quantity of dry Sephadex in g							
				G-10	G-15	G-25	G-50	G-75	G-100	G-150	G-200
K 25/100	2.5	100	485	245	165	100	50	40	35	25	20

XBL 7310-4224

Fig. 12. Sephadex laboratory coloumn K25/100 with accessories.

with two end pieces of superpolyoxymethylene. The top piece had an eluant (or solvent, these two terms are used interchangeably) inlet port for connection to the eluant reservoir. The vent hole was for removal of air from the system. The bottom piece was fitted with a 400 mesh nylon net which was supported by a coarse nylon screen and locked into place with a P. V. C. ring. A specially designed screw nipple outlet spout could easily be attached to a capillary tubing.

The column was mounted vertically and the dead space under the net and tubing filled with eluant. This was done by injecting the liquid into the outlet tubing and pumping it up through the bed support net. When the dead space was properly filled the outlet port was closed. The gel slurry was then poured down the wall of the column and what any space left on the top was filled with eluant so that the column was completely full. The eluant reservoir was connected to the top of the column by capillary tubing and the last traces of air removed through the air vent. Flow of the eluant was started immediately. The operating pressure depended upon the difference between the free surface of the eluant reservoir and the outlet. For the Sephadex K25/100 column using G-75 gel the allowable operating pressure suggested by manufacturers (Pharmacia Fine Chemicals Company) was between 40-100 cm H₂O and this limit was strictly obeyed. Between two to three column volumes of eluant was passed through the column in order to stabilize and equilibrate the gel bed.

After equilibrium the bed was ready for application of the sample. This was done with a flow adapter which is an adjustable column end piece. With the column nearly full with liquid the adapter

mechanism was lowered until it just touched the top of the gel bed. The column outlet tubing was closed during this operation, the eluant above the bed leaving through the capillary tubing of the adapter. Sample was then applied on the top of the bed through the adapter. The entire exercise was geared to analytical purpose, the main objective being attaining as good separation as possible. Hence sample volumes were kept small, between 3 ml and 5 ml. After layering the sample on top of the gel bed the column top was slowly filled with eluant without disturbing the surface. The top piece was screwed back on making sure that no air bubbles were left behind and eluant flow from the reservoir started. Simultaneously the outlet tubing from the bottom of the column was unclamped.

The outlet capillary discharged column effluents through a photoelectric volumetric actuating unit (Model LVM1, Gilson Medical Electronics, Inc., Middleton, Wisconsin) to a Gilson Linear Fraction collector (Model LB1). The volume collected was adjustable over the range of each volumetric cylinder (standard range 1 ml to 15 ml). A light from a fluorescent source was focused on a light dependent resistor by means of the cylindrical lens formed when the collecting cylinder was filled with the sample. The light dependent resistor actuated a relay, the fractionator was indexed to the next tube, the ball and socket valve opened and emptying occurred.

The entire unit was enclosed inside a Gilson Model FRW refrigerator with temperature maintained at 4° C during its operation. The individual fractions collected were subsequently removed and assayed for enzyme activity and protein concentration.

Literature cited in Chapter 3

- 1) Halliwell, G., 'Advances in Enzyme Hydrolysis of Cellulose and Related Materials', E. T. Reese, ed., p. 71, Pergamon Press (London) (1963).
- 2) Mandels, M., and J. Weber, *Advances in Chem. Series*, 95, 391 (1969).
- 3) Viles, F. J., and Silverman, L., *Anal. Chem.*, 21(8), 950 (1949).
- 4) Updegraff, D. M., *Anal. Biochem.*, 32, 420 (1969).
- 5) Sumner, J. B., G. F. Somero, 'Laboratory Experiments in Biological Chemistry', Academic Press, New York (1944).
- 6) Lowry, O. H., N. J. Rosebrough, A. L. Farr, and R. J. Randall, *J. Biol. Chem.*, 193, 265 (1951).
- 7) Koch, A. L., and S. L. Putman, *Anal. Biochem.*, 44, 239 (1971).
- 8) Bandopadhyay, B., and A. E. Humphrey, *Biotech and Bioengg.*, IX, 533 (1967).
- 9) Loeb, S., and Sourirajan, S., *Advan. Chem. Series*, 38, 117 (1963).
- 10) Michaels, A. S., *Chem. Eng. Prog.*, 64(12), 31 (1968).
- 11) DeFillipi, R. P., and Goldsmith, R. L., *Membrane Science and Technology*, Plenum Press, New York (1970).
- 12) Goldsmith, R. L., *Ind. Eng. Chem. Fund.*, 10(1), 113 (1971).
- 13) Flory, P. J., *Principles of Polymer Chemistry*, Cornell Univ. Press, N.Y. (1957).

- 14) Smith, K. A., Colton, C. K., Merrill, E. W., Evans, L. B.,
Chem. Eng. Prog. Symp. Series 64(84), 45 (1968).
- 15) Lathe, G. H., and C. R. Ruthven, Jr. Biochem. J., 62, 665
(1956).
- 16) Porath, J., and P. Flodin, Nature, London, 183, 1657 (1959).
- 17) Determann, H., "Gel Chromatography," Springer Verlag, N.Y.,
1968.
- 18) Gelotte, B., and J. Porath, "Chromatography" (2nd edition),
Reinhold Publishing Corporation, N.Y., 1967.
- 19) Andrews, P., Biochem. J., 91, 222 (1964).
- 20) Selby, K., C. C. Maitland, Biochem. J., 104, 716 (1967).
- 21) Flodin, P., Dissertation, AB Pharmacia, Uppsala, Sweden
(1962).
- 22) Porath, J., J. Appl. Chem., 6, 233 (1963).
- 23) Squire, P. G., Arch. Biochem. Biophys., 107, 471 (1964).
- 24) Marsden, N. V. B., Ann. N.Y. Acad. Sci., 125, 428 (1965).

4. RESULTS AND DISCUSSIONS

4.1. Enzyme Characteristics

Organisms used in the present investigation were Trichoderma viride QM6a and Trichoderma viride QM9414 obtained from U. S. Army Natick Laboratories at Massachusetts. The strain QM9414 was a mutant strain obtained by irradiating conidia of strain QM6a with a linear accelerator (1) secreting twice as much cellulase per unit dry weight of biomass. The growth characteristics in terms of biomass production with time were, however, similar for both these strains.

Trichoderma viride QM6a cultures were grown in batch fermentors of 5 L. liquid volume utilizing the mineral medium suggested by Mandels and Weber (2). The carbon source was pure spruce wood cellulose as 0.5% Solka Floc (Brown Company, Providence, R. I.). Temperature was controlled at 30°C and aeration was carried out at 0.5 V. V. M. At the end of the fourth day the batch was harvested, the mycelium-liquid mixture centrifuged at 10,000 rpm for 10 minutes in the refrigerated centrifuge (4°C) and the clear pale yellow colored supernatant collected. The average soluble protein content of this supernatant was measured by modified Biuret reagent to be 382 µg/ml corresponding to an enzyme activity of 0.80 filter paper activity. This enzyme was used for ultrafiltration experiments. For all the ultrafiltration runs 200 ml of the enzyme solution was used inside the cell utilizing Amicon PM 30 membrane of area 4.27 in.². At operating

pressure of 20 psig the flux through the membrane with time is shown in Figure 13. Concentration of the enzyme solution was carried out in this setup between factors of 2.0 and 10.0 and the distribution of C_1 , C_x , filter paper activity and soluble protein measured in the filtrate and the concentrate. The results obtained are shown in Table 3.

The overall soluble protein recovery remained fairly constant over this experimental range, the average value being 96.4%. The loss of about 4% of the soluble protein was attributable to the adsorption loss on the membrane itself, a phenomenon quite common to ultra-filtration operation at intermediate pressures. Percentage of total protein in the filtrate initially progressively increased with the increase in concentration factor, finally reaching a more or less constant value.

Since the cut-off point of the PM-30 membrane is at a molecular weight of 30,000 the experimental results would indicate that about half of the total soluble protein is of molecular weight lower than 30,000. C_x -activity is generally associated with the lower molecular weight components of cellulase enzyme and the soluble protein in the filtrate should correspond to the C_x -activity. Distribution of C_x -activity in the concentrate and the filtrate corroborated this observation. C_x -activity in the filtrate increased initially with increase in concentration factor finally slowly approaching a constant value. Total C_x -activity in the filtrate and concentrate combined remained fairly constant at an average value of 61.48% through the entire range of the experiment. This loss of an average 38.52% could not obviously be attributed to the

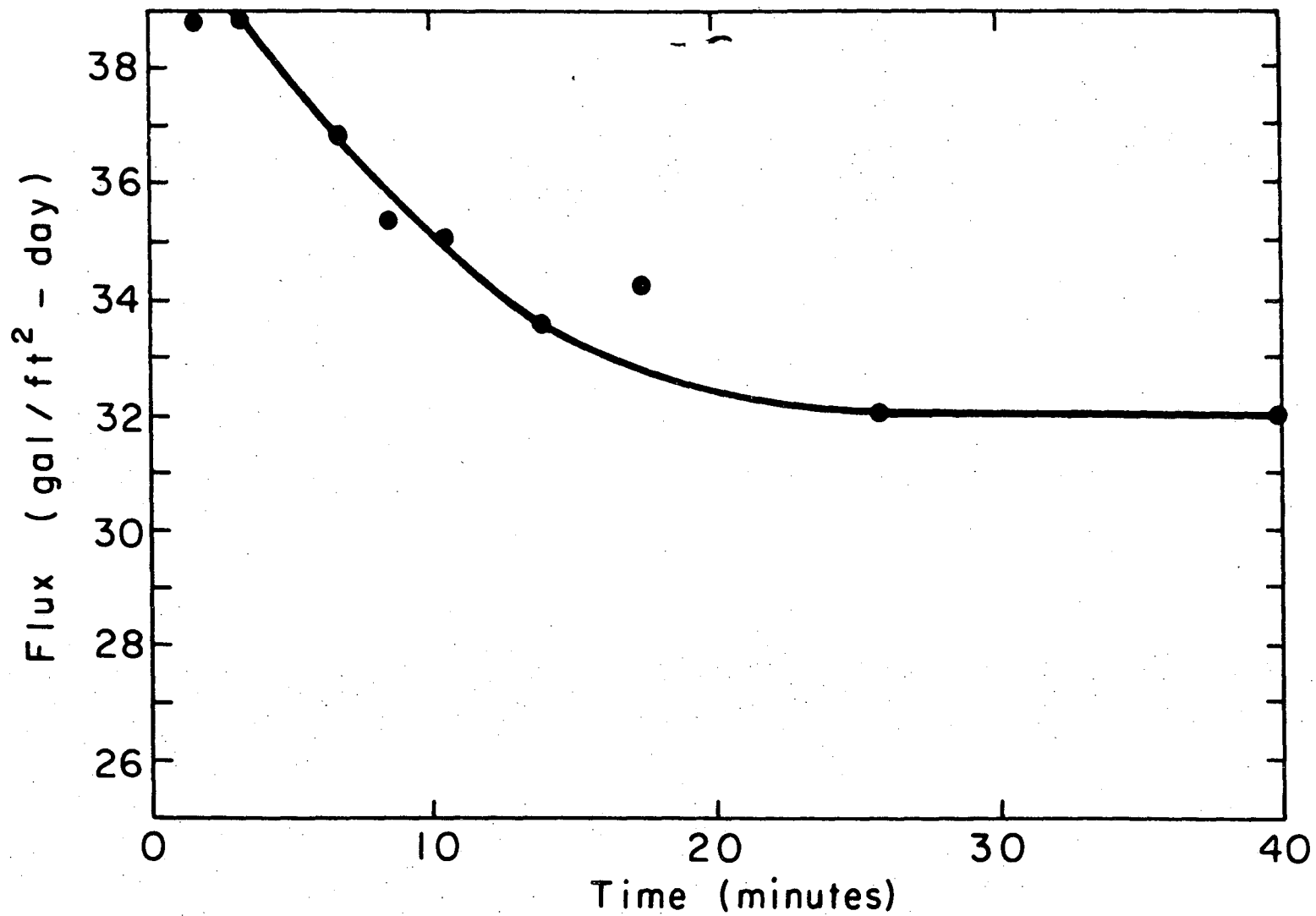

-89-

XBL7310-4328

Fig. 13. Membrane flux with time.

Table 3. Culture filtrates centrifuged at 10,000 rpm 4° C for 10 minutes. 200 cc of supernatant (average protein content 382 µg/ml, 0.80 filter paper activity) used in the ultrafiltration cell for all concentration experiments. No reducing sugar present.

Concentration factor	Protein recovery (%)	Distribution of Total Protein		Total C _x recovery (%)	Distribution of Total C _x Activity		Recovery of filter paper activity (%)	Recovery of C ₁ -cotton activity (%)
		Concentrate (%)	Filtrate (%)		Concentrate (%)	Filtrate (%)		
2.00	98.88	76.32	22.56	62.28	62.28	Trace	100.00	62.50
3.28	95.61	58.93	36.68	57.37	43.18	14.19	82.39	48.35
5.00	95.83	53.83	42.00	60.61	27.63	32.98	67.53	42.07
6.67	96.17	48.10	48.07	64.45	20.95	43.50	58.50	43.09
8.33	96.00	47.80	48.00	61.30	15.08	46.22	60.50	37.10
10.00	95.81	47.31	48.50	15.62	15.62	47.25	62.67	31.36

adsorption loss only since the average protein loss was only 3.6%. During the ultrafiltration experiments C_1 activity was confined in the concentrate, none escaping to the filtrate. Synergism of C_1 and C_x would explain this overall loss of C_x -activity. This observation is very significant because in this context we are talking about synergism vis-a-vis substrate carboxymethyl cellulose (CMC). According to the 2-step C_1 - C_x theory of Reese et al., it is the C_x component which is dependent upon the C_1 -fraction for hydrolysis of native cotton but the C_x -fraction by itself is perfectly capable of hydrolyzing soluble CMC. Selby and Maitland (4) also published results supporting the above hypothesis. This obviously was not the case in the present investigation, the partially purified C_x -fractions losing a substantial part of their activity towards CMC. The unienzyme concept of breakdown of cellulose is probably more valid in interpreting these results, the Nisizawa et al., (5) theory of cellulase components with 'more' or 'less' random mechanism towards various cellulosic substrates being pertinent in this context. C_x itself is not a single enzyme and hence by ultrafiltration we have essentially separated 2 fractions of C_x above and below molecular weight of 30,000. It seems that there is a very strong synergistic action among these various fractions of C_x component for hydrolytic action towards CMC, the overall loss of activity being directly related to the separation of the enzyme mixture around a fixed molecular weight. This was further substantiated (as will be seen in a subsequent section) during gel filtration experiments with the concentrate and the filtrate obtained from these experiments.

C_1 -activity during these experiments never escaped in the filtrate. There was a progressive decrease in C_1 -activity recovery at higher concentrations from 62.50% at a concentration factor of 2.0 to 31.35% at a concentration factor of 10.0. The loss of activity at higher concentration factors was related to the fraction of protein escaping into the filtrate. This, in other words, indicates that C_1 activity is strongly dependent upon the simultaneous presence of C_x fractions of the enzyme. This essentially corroborates the results reported by Selby and Maitland (4) with purified fractions of Trichoderma viride cellulase. Filter paper activity recovery during these observations initially decreased sharply with increase in concentration factor and subsequently reached a more or less constant value around 60%.

An analysis of the ultrafiltration system assuming a stirred tank model on the high pressure side is presented below.

Let

- V be the volume of liquid in the high pressure side.
- x be the concentration of protein fraction of molecular weight less than 30,000 in the concentrate.
- F be the rate of ultrafiltration through the membrane.
- t be the elapsed time.

Assuming a sieving model so that all the protein of M. W. < 30,000 can pass through the membrane unimpeded

$$-Fx = V \frac{dx}{dt}$$

or

$$-F/V = \frac{1}{x} \frac{dx}{dt}$$

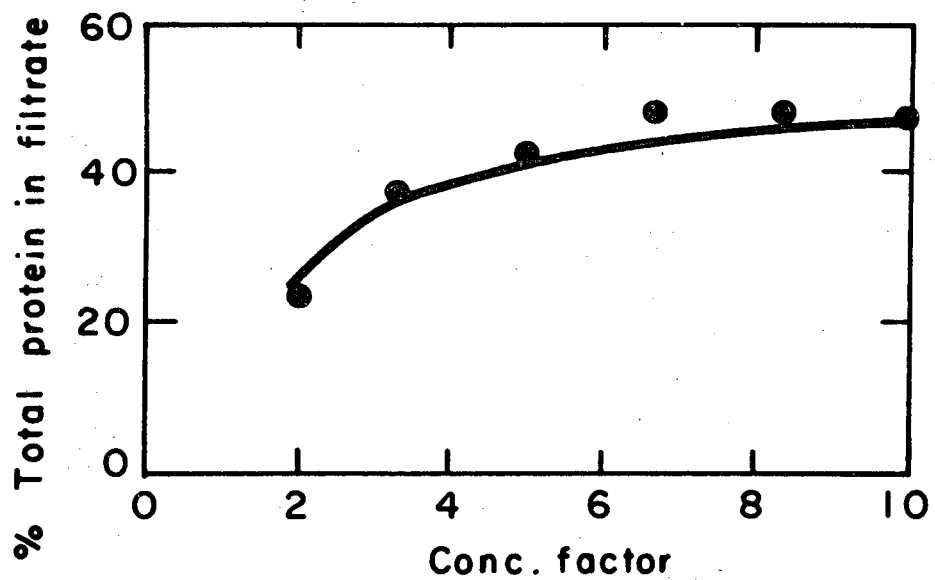

XBL7310 - 4330

Fig. 14. Stirred tank model for ultrafiltration.

If V_0 is the initial volume, $V = V_0 - Ft$

or

$$\frac{+F}{(V_0 - Ft)} dt = \frac{-dx}{x}$$

Integrating with boundary conditions

$$\text{at } t = 0, \quad x = x_0$$

$$\text{at } t = t, \quad x = x_1$$

$$\ln\left(\frac{V_0}{F}\right) - \ln\left(\frac{V_0 - Ft}{F}\right) = \ln \frac{x_0}{x_1}$$

or

$$\ln \frac{V_0}{V_0 - Ft} = \ln\left(\frac{x_0}{x_1}\right)$$

Assuming 51% of the initial soluble protein mixture to be of MW < 30,000 the theoretical curve corresponding to the above equation is shown in Fig. 14. The experimental points are also shown side by side. As shown, a reasonably good corroboration was obtained between C. S. T. R. assumption and the experimental observations.

Gel chromatographic runs were made with concentrates and filtrates of the ultrafiltration experiment mentioned above. Figure 15 depicts the chromatogram for the concentrate of concentration factor 3.28. The G-75 Sephadex packed column of dimension 85×2.5 cm was used with a 3 ml sample size and flow rate of eluting buffer between 5-8 ml/hr. 5 ml fractions were collected with the automatic fraction collector and contents of each fraction assayed for protein content by the modified Biuret method. Three distinct protein peaks

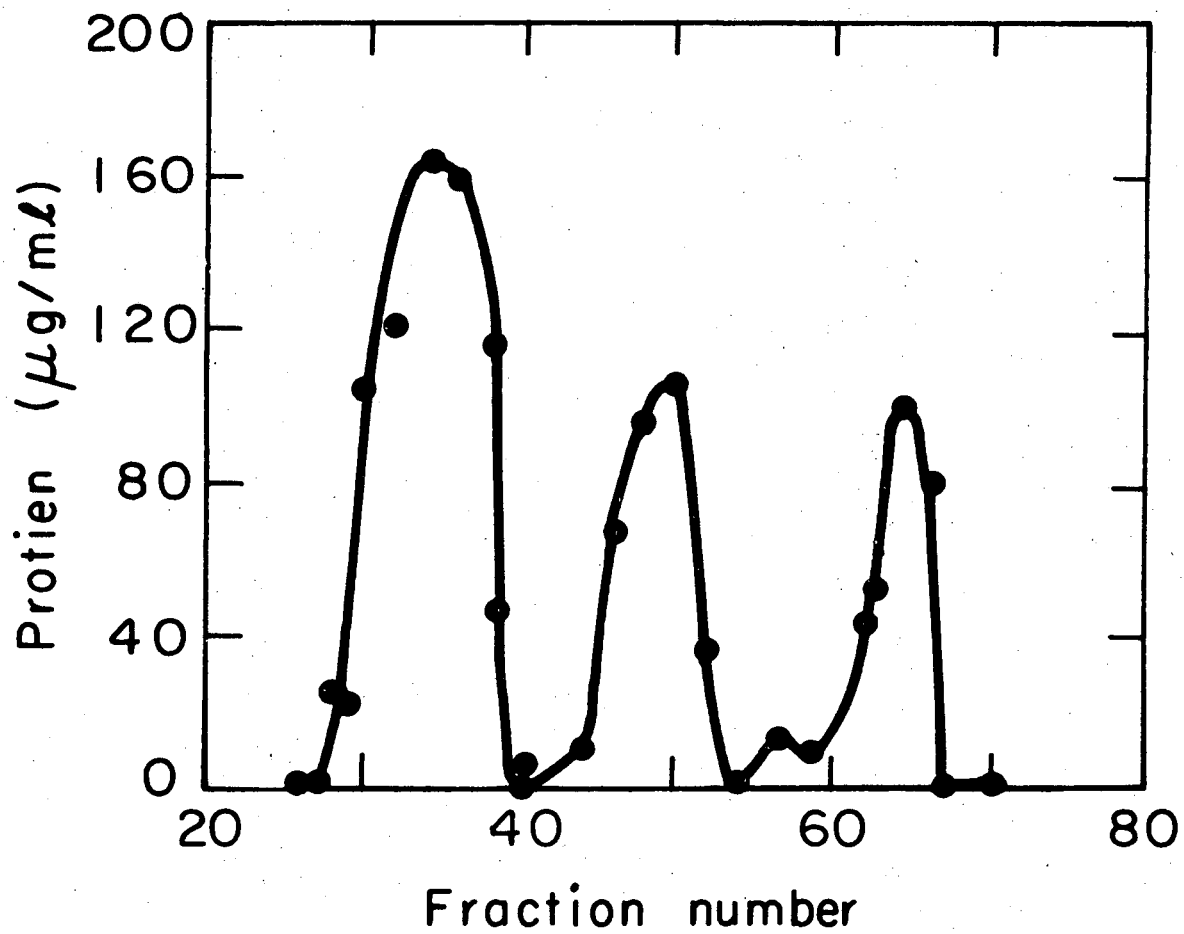

XBL729-4081

Fig. 15. Chromatogram of concentrate (X3.28).

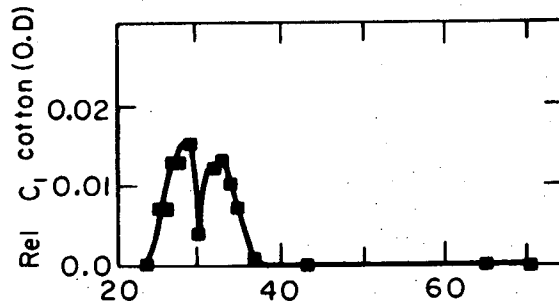
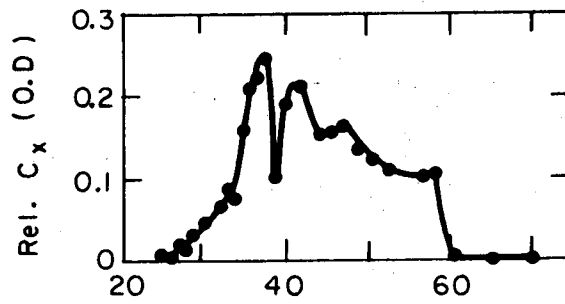
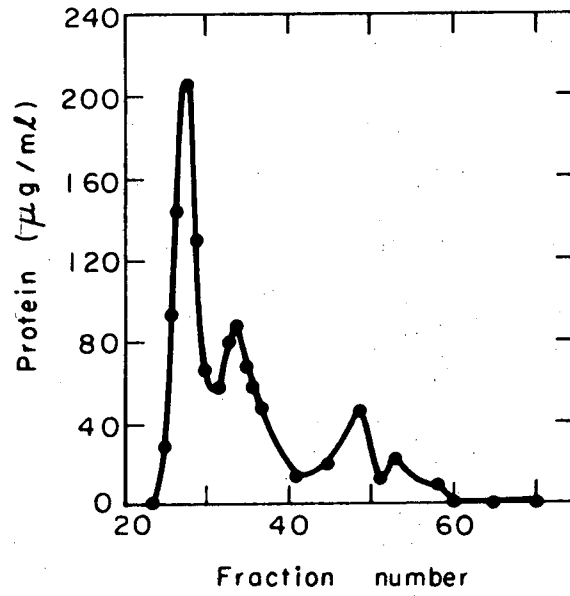

XBL729-4080

Fig. 16. Chromatogram of concentrate (X 8.33).

were obtained, the molecular weight of these peaks decreasing with increasing fraction numbers. Figure 16 depicts the gel filtration run with a 5 ml sample of concentration factor 8.33, the other operating conditions being exactly the same as that of the previous case. The protein peak after fraction number 60 was not present here due to its passage through the ultrafiltration membrane. Also the peak between fractions 45 and 53 became shorter. This according to Table 3 corresponded to an increase in the total protein content in the filtrate from 37% to 48%. Figure 16 also shows the relative C_1 and C_x activities corresponding to the collected fractions. To account for dilution effects hydrolysis time for C_x estimation was increased from 30 to 160 minutes. C_x activity was distributed over the various fractions whereas C_1 activity was only found between fractions 24 and 37. C_1 fraction of cellulase is generally understood to have the highest molecular weight (~ 65,000) of the protein mixture and the observation that it is eluted first from the gel column is in agreement with this. The C_1 activity in the individual fractions, however, was substantially lower than that in the concentrate. The C_1 fractions between 24 and 37 were pooled together and an estimation of C_1 activity of this pool could only account for about 5% of the total activity present in the entire concentrate. This obviously suggests that C_1 -activity is strongly dependent upon simultaneous presence of C_x -activity. The ultrafiltration results shown in Table 3 also corroborate this observation.

Figure 17 shows gel filtration run with 5 ml sample from the filtrate obtained during concentrating cellulase by a factor 6.67 in the ultrafiltration cell. The buffer flow rate was 29 ml/hr and the column

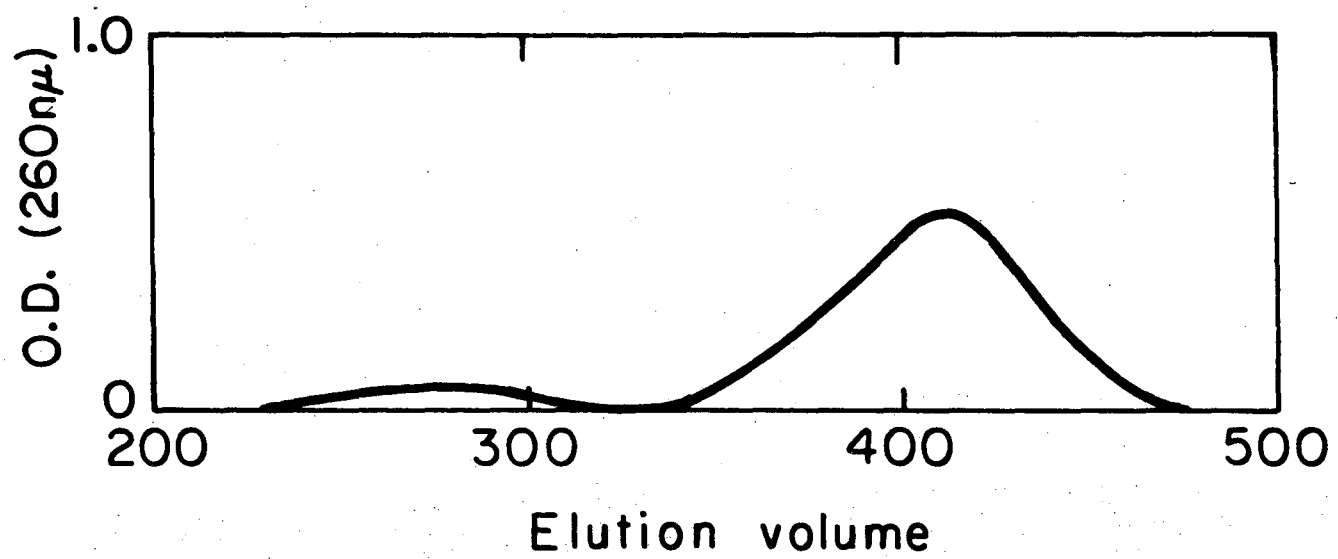

XBL7310-4329

Fig. 17. Chromatogram of filtrate (X 6.67).

dimensions 79×2.5 cm. The protein content of the effluent stream was measured automatically as extinction coefficient at 260 m μ . Two very flat peaks were obtained as shown in Fig. 17. C_x assay of the individual fractions did not show any activity, when pooled together, however, the C_x activity of the filtrate was easily accounted for. This supports the earlier findings of ultrafiltration observations; that C_x activity is strongly dependent upon the presence of all of its constituent fractions for its hydrolytic action towards soluble CMC.

4.2. Growth of the fungus *T. viride* and enzyme production

4.2.1. Development of a low cost growth medium

Nutrient compositions for submerged culture growth of *Trichoderma viride* have been reported in the literature by the research group at Natick, Massachusetts as early as 1957 (6). Subsequent papers (7)(8) reported the effects of several oligosaccharides on induction of cellulase. The concept of adding a soluble protein in the growth medium as a suitable growth factor developed concurrently in these findings. The resulting optimum medium described by Mandels and Weber (2) has the composition shown in Table 4. Rosenbluth and Wilke (9) utilized this medium for their process design study based on cell growth and enzyme production rate data obtained at Natick. Utilizing chemically pure materials the cost of the medium necessary for treatment of a ton of cellulose was estimated to be \$24.00, or roughly 2 cents per pound of sugars produced by the process. Since the cost of reducing sugars has to be less than 4 cents per pound in order to make ethanol fermentation competitive with petrochemical synthesis, it was decided

Table 4. Growth medium of Mandels and Weber (2).

Compound	Amount (grams/liter)	Cost/pound
$(\text{NH}_4)_2\text{SO}_4$	1.4	\$ 0.10
(KH_2PO_4)	2.0	0.10
$(\text{NH}_2)_2\text{CO}$	0.3	0.047
CaCl_2	0.3	0.29
$\text{MgSO}_4 \cdot 7\text{H}_2\text{O}$	0.3	0.029
Proteose Peptone	0.5	0.20
Carbon Source*	10.0	0.20

Trace metal ions in milligram/liter: Fe^{++} , 1.0; Mn^{++} , 0.8; Zn^{++} , 0.5; CO^{++} , 0.5.

* SOLKA FLOC, if enzyme is to be produced, dextrose if only growth of the fungus is desired.

that the development of a low-cost growth medium is essential for the process to become economically feasible.

The use of commercial fertilizers was investigated in place of inorganic chemicals and cotton seed oil in place of proteose peptone. The materials described in Table 5 were tested over a range of relative amounts for the growth of T. viride QM9414 in the presence of soluble sugars (hydrolysis products of newsprint) as carbon source. The optimum medium composition was estimated to consist of component A 2.5 gm/1, component B 0.5 gm/1 and component C 0.05%.

The constituents in the above proportions were mixed with appropriately

Table 5. Low cost medium components.

Component	Description	Major Constituents	(%)	Cost/ pound
A. Kellogg Superphosphate	Inorganic Fertilizer	Phosphoric acid (available)	20.0	\$0.02
		Anhydrous calcium sulfate	51.0	
		Combined sulfur (from calcium sulfate)	12.0	
B. Kellogg "All Purpose" Plant Food	Organic-Inorganic Fertilizer	Organic Nitrogen	8.0	\$0.02
		Phosphoric Acid (available)	8.0	
		Potash (water soluble)	4.0	
		Iron (as sulfate)	3.0	
		Calcium (as sulfate)	3.0	
		Combined sulfur (from sulfates)	2.0	
		Magnesium (as sulfate)	1.0	
		Zinc (as sulfate)	0.3	
		Manganese (as sulfate)	0.1	
		Copper (as sulfate)	0.1	
		Aluminum	0.1	
C. Proflo Oil	Cottenseed oil mfg. by Traders Protein Div., Ft. Worth, Texas	Protein (Kjeldahl basis)	61.0	\$0.11

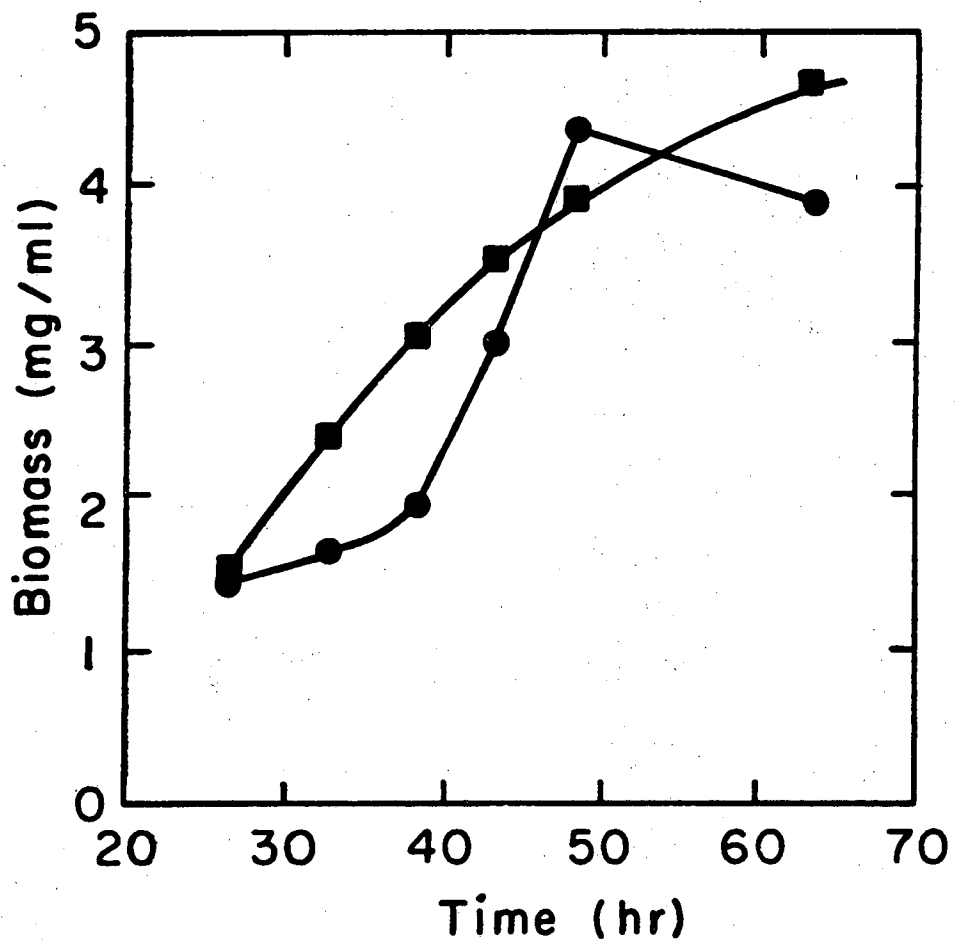

XBL733-2376

Fig. 18. Growth Data of *Trichoderma viride* QM9414 on Hydrolysis Products of Saccharification Initial Reducing Sugar Concentration 10 mg/ml pH 4.8, temperature maintained at 30° C.

- Superphosphate/Proflo Oil Medium
- Chemical Grade Pure Medium

diluted hydrolysis products of reducing sugar concentration 10 mg/ml and passed through a Waring Blender for ten minutes. This facilitated the dissolution of a major part of solids; the liquid was then decanted and sterilized in the Miniform with a liquid volume of 500 ml. An identical run was made with the Natick chemical grade medium and the comparison of biomass production with time for these two cases is shown in Fig. 18. For biomass measurement 10 ml samples were drawn at appropriate time intervals and centrifuged at 10,000 rpm for 10 minutes at 4°C. The clear liquid as supernatant was discarded and modified Biuret method utilized to measure the protein content of the precipitate. From the standard curve of dry weight against protein the biomass values were ascertained. As depicted in the figure, the two media appear to be essentially equivalent for the production of cell mass, with very substantial cost advantage in favor of the crude medium.

4.2.2. Q_{O₂} Measurement

Three experiments were carried out to determine the specific oxygen demand Q_{O_2} during the exponential growth of the fungus on 1% dextrose at 30°C. The rate of depletion of oxygen with time after air turn off at 3 different biomass concentrations is shown in Fig. 19. The linear decrease of oxygen in the initial period can be tabulated as follows:

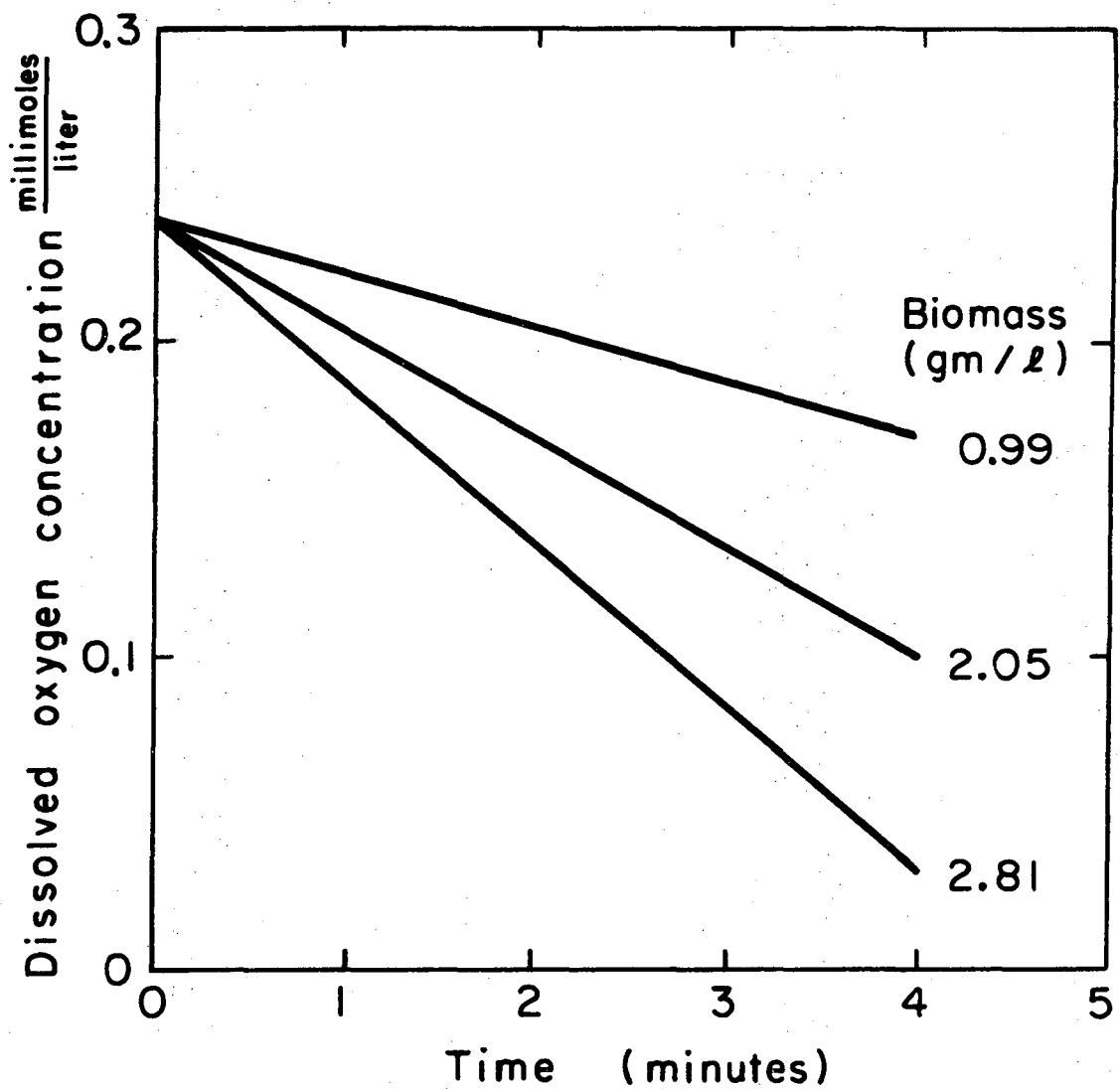

XBL7310-4327

Fig. 19. Dissolved oxygen decrease with time after air turn off for exponentially growing *T. viride* on 1% dextrose at 30° C.

Biomass concentration (gm/1)	Rate of O ₂ consumption milli- moles $1 \times \text{min}$	Q_{O_2} millimoles O ₂ gm dry wt \times hr
0.99	1.70×10^{-2}	1.03
2.05	3.42×10^{-2}	1.0
2.81	5.15×10^{-2}	1.1

Typical Q_{O_2} values for various microorganisms have been reported in literature (11) and a sample of representative values may be mentioned below in this context:

Organism	Q_{O_2} millimoles O ₂
<u>E. coli</u>	10.8
<u>S. cerevisiae</u>	8.0
<u>P. chrysogenum</u>	3.9
<u>A. niger</u>	3.0
<u>S. griseus</u>	3.0

In general the specific oxygen demand decreases from bacterium to fungi and the experimental values obtained here for T. viride fall in the lower end of the spectrum. While comparing Q_{O_2} values, however, it should be remembered that all of these reported results were obtained by employing different chemical and manometric methods. Dynamic response method employed in the present investigation is a relatively new technique and a true comparison can only be made when experimental techniques employed are the same in all cases.

Based on the experimental values of Q_{O_2} the following analysis shows that oxygen concentration was not limiting during the growth of the fungus on 1% dextrose:

$$\begin{aligned}
 \text{Yield constant } (Y_{x/s})_{\text{Expt}} &= 0.43, \text{ hence } \max^m \text{ biomass} = 4.3 \frac{\text{mg}}{\text{ml}} \\
 \text{Liquid volume} &= 5 \text{ liters} \\
 \text{Aeration rate} &= 2.5 \text{ l/min} = 150 \text{ l/hr} \\
 \text{Oxygen consumption rate} &= Q_{O_2} \times x = 1.0 \times 4.3 \\
 &= 4.3 \frac{\text{millimoles } O_2}{\text{liter} \times \text{hr}} \\
 &= 4.3 \times 5 \\
 &= .0215 \frac{\text{moles } O_2}{\text{hr}}
 \end{aligned}$$

If Y is the mole-fraction of O_2 in air stream an O_2 balance over the fermentor

$$(\text{Air outflow}) Y_{\text{out}} = (\text{Air inflow}) Y_{\text{in}} - \text{oxygen consumption}$$

$$\text{Mol. wt. of air} \quad 28.84$$

$$\begin{aligned}
 \text{Incoming sterile air} = 150 \text{ l/hr} &= \frac{150 \times 10^3}{82.05 \times 303} \frac{\text{gm moles}}{\text{hr}} \\
 &= 6.02 \frac{\text{gm moles air}}{\text{hr}} \\
 &= 0.21 \times 6.02 = 1.264 \frac{\text{gm moles } O_2}{\text{hr}}
 \end{aligned}$$

$$\begin{aligned}
 Y_{\text{out}} &\approx \frac{1.264 - 0.0215}{6.02} \\
 &= \frac{1.2425}{6.02} = 0.206
 \end{aligned}$$

$\frac{0.206}{0.21} = 98\%$ of the oxygen non-utilized and only 2% of the oxygen in the air stream is utilized for biomass production.

Hence the assumption of oxygen concentration being non-limiting in the analysis of the data should be valid.

4.2.3. C.S.T.R. runs with soluble sugars

C.S.T.R. runs for the growth of Trichoderma viride were made with 0.5% and 1% glucose as carbon source with temperature controlled at 30° C and sterile air supplied at 0.5 V. V. M. Dissolved oxygen probe readings were monitored throughout making sure that the concentration of oxygen in the fermentor liquid never became critical and growth was controlled only by the concentration of the limiting substrate and the dilution rate. The operating liquid volume in these experiments was 5 liters. The batch growth was continued till essentially all the substrate was utilized; the feed stream to the fermentor was then initiated starting the continuous operation. After a throughput volume twice that of the volume of the fermentor liquid assay of reducing sugars in the fermentor liquid was initiated at the interval of one hour till a steady state value was obtained. In general, steady state was achieved in these operations immediately after a throughput volume of twice that of the fermentor liquid. Sterility checks of all observations were made with dilution streaks on potato-dextrose agar and microscopic examination. No apparent contamination was noticed.

An estimation of specific growth rate μ with substrate concentration S was made according to the following analysis

Let x be the biomass concentration

V be the volume of liquid in the fermentor

F be the medium flow rate

$$V \frac{dx}{dt} = -Fx + V \frac{dx}{dt} \cdot \text{growth} = -Fx + Vx\mu$$

or
$$\frac{dx}{dt} = x\left(\mu - \frac{F}{V}\right)$$

or
$$x_1 = x_1' e^{(\mu - D)t}$$

with boundary conditions at $t = 0, x = x_1'$
 $t = t, x = x_1$

Hence variations of x with t was measured during unsteady state operation making certain that $t = 0, D \neq \mu$. From these observations values of specific growth rate μ were calculated. Substrate concentrations were also experimentally determined during these observations and the resulting μ vs. S curve is shown in Fig. 20. A Lineweaver Burk type plot was also drawn from the above figure and the maximum growth rate μ_{\max} was estimated at 0.294 hr^{-1} .

Steady state operation results are shown in Figures 21 and 22 for 0.5% and 1.0% inlet dextrose concentration. A maximum productivity of cells at $0.47 \frac{\text{mg}}{\text{ml} \times \text{hr}}$ was obtained at a dilution rate of 0.21 hr^{-1} for 0.5% inlet sugar concentration. The corresponding value for 1.0% inlet sugar concentration was $0.92 \frac{\text{mg}}{\text{ml} \times \text{hr}}$ at a dilution rate of 0.21 hr^{-1} .^{*} Reported values of cell productivity for fungus in a

* Higher inlet sugar concentrations were not investigated thoroughly in this study due to time limitations although substrate inhibition was noted around 3% inlet sugar concentration.

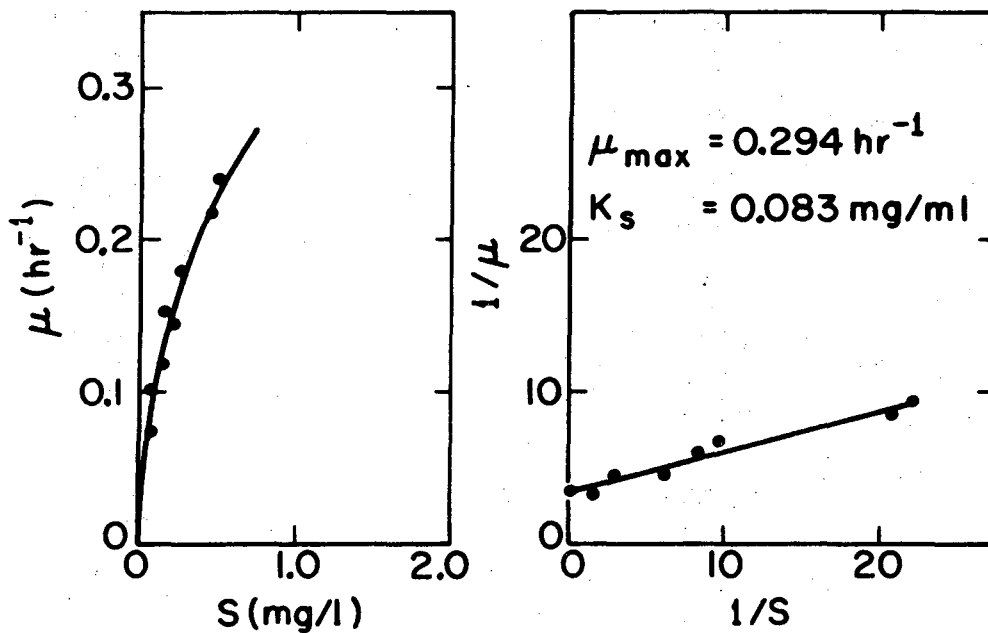

XBL7310-4172

Fig. 20. Unsteady state observations, substrate 0.5% glucose, pH 4.8, temp 30° C.

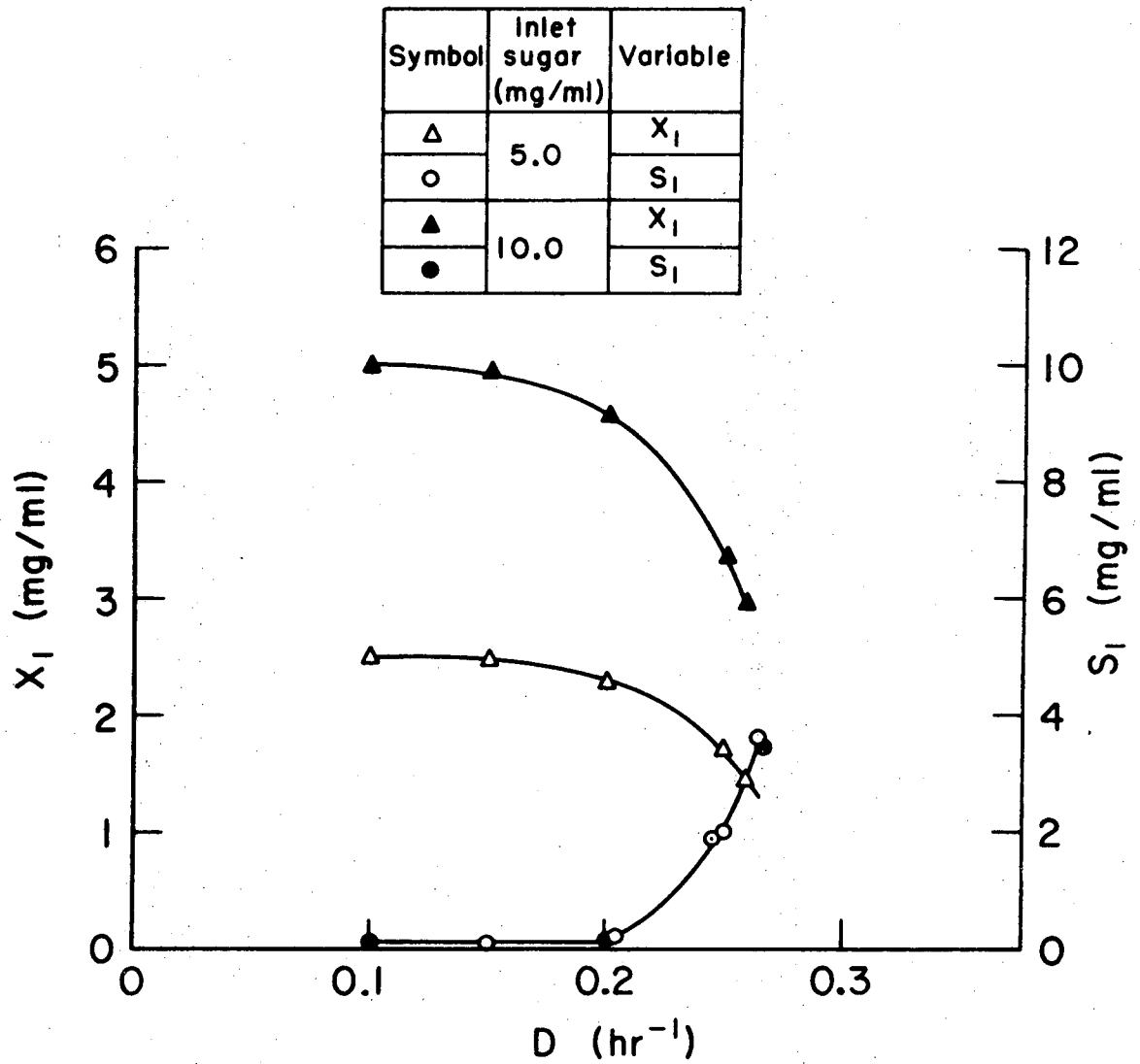

XBL7310-4169

Fig. 21. Continuous culture (C.S.T.R) operation. D → dilution rate, S_1 → outlet sugar concentration, X_1 → outlet fungal biomass concentration.

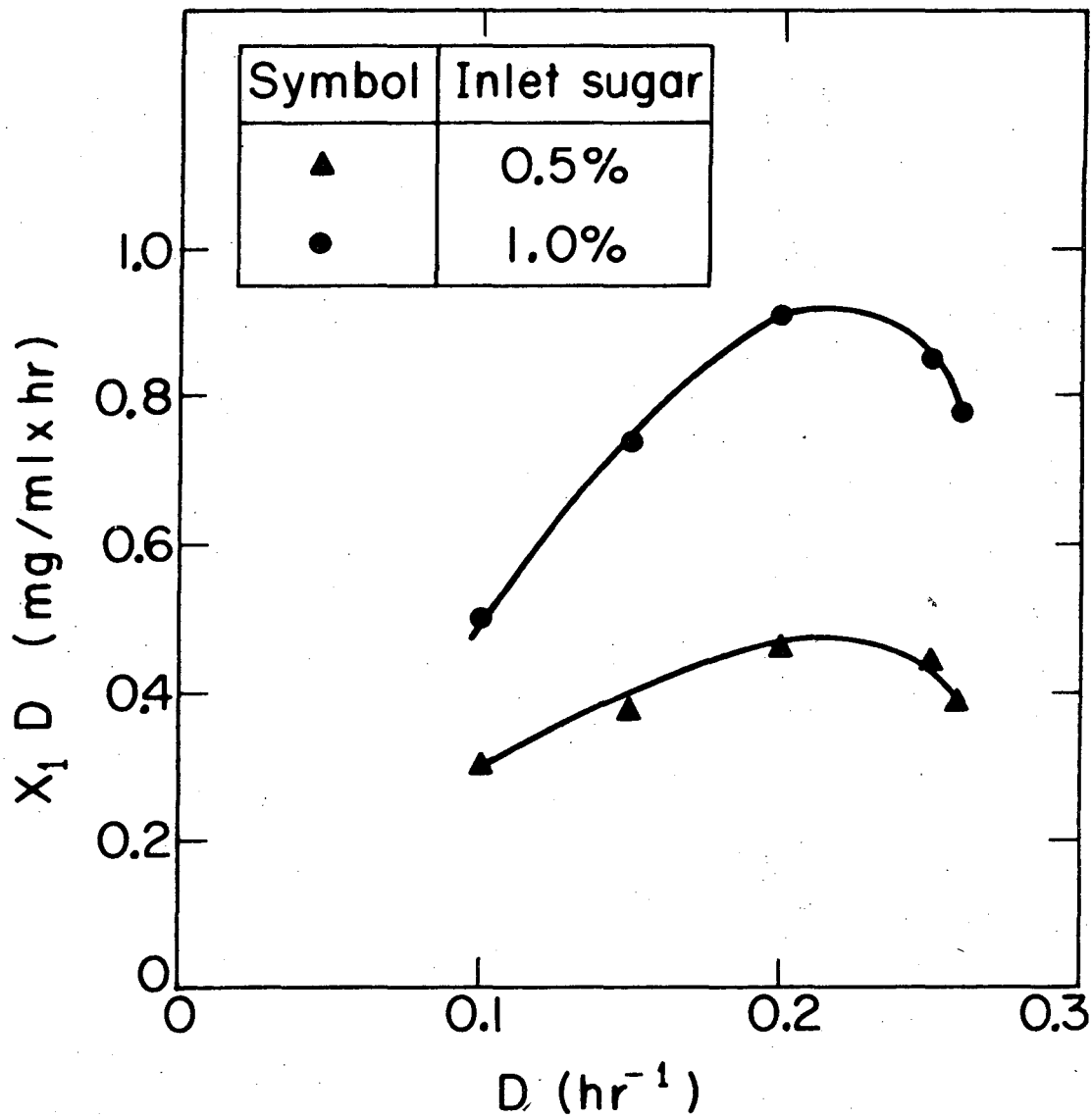

XBL7310-4171

Fig. 22. Cell productivity ($X_1 D$) with dilution rate (D).

submerged culture fermentation usually fall in the range of 0.25 and 0.35 $\frac{\text{mg}}{\text{ml} \times \text{hr}}$ for 0.5% inlet substrate concentration and hence the obtained value was about 1.5 times higher. Literature reported values for the growth of the fungus on insoluble substrate (2) place the dilution rates in the neighborhoods of 0.2 day⁻¹ for maximum cell productivity. Hence an increase of about 25 times in cell productivity was obtained utilizing a soluble substrate.

4.2.4. Batch Growth and Enzyme Production on Insoluble Substrate

T. viride QM6a growth in the presence of 1.0% Solk Floc (pure spruce wood cellulose) as the sole carbon source was conducted in 5-liter liquid volumes at 30°C. Samples were drawn at regular intervals and assayed for fungal biomass and enzyme activity. pH was externally controlled at 4.8 and the results obtained are shown in Figure 23. An enzyme activity of 1.0 Filter Paper activity was generally achieved in a 7-day period. Enzyme production was growth associated in the exponentially growing phase and a general Ludeking Piret type expression was valid for enzyme activity measurement.

If

x be the biomass concentration

P be the enzyme activity

t be the elapsed time

α, β be empirical constants

Then an empirical relationship of Ludeking Piret type for enzyme activity yields

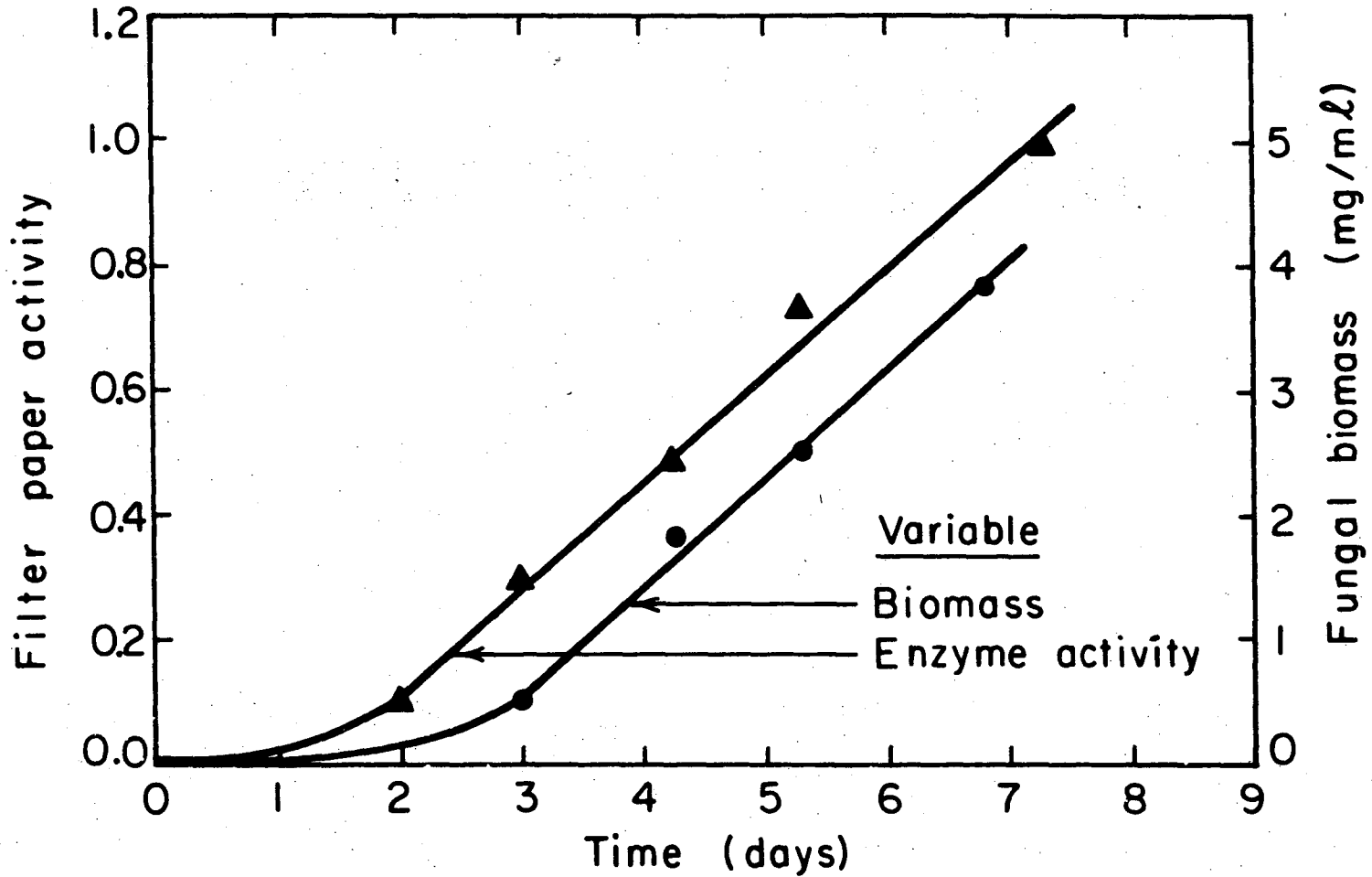

XBL7310-4326

Fig. 23. Batch growth and enzyme production of T. viride QM6a on insoluble substrate.

$$\frac{dP}{dt} = a \frac{dx}{dt} + \beta x$$

during exponential growth, (specific growth rate) $\mu = \mu_{\max}$

$$\begin{aligned} \therefore \frac{dP}{dx} &= \left(a + \beta \frac{x}{\frac{dx}{dt}} \right) \\ &= (a + \beta/\mu_{\max}) \frac{dx}{dt} = \text{Const} \times \frac{dx}{dt} \end{aligned}$$

from the experimental values the following relationship can be obtained for the exponential phase

$$\frac{dP}{dt} = 0.205 \frac{dx}{dt}$$

where $P \rightarrow$ Filter Paper activity, $t \rightarrow$ days, $x \rightarrow$ mg/ml.

Trichoderma viride QM9414 has been reported in the literature (1) to secrete more than twice as much enzyme per unit dry weight of biomass as the QM6a strain. Experiments were run to verify this observation with the strain of T. viride QM9414 obtained from Army Natick Laboratories in Massachusetts and enzyme production compared with that from T. viride QM6a. Batch runs with 5-liter liquid volumes were run with 0.5% Solka Floc as the sole-carbon source at 30°C. Initial pH of the medium was adjusted at 4.8 and no further external pH control was maintained. After 5 days the batch was stopped, the culture harvested, and the supernatant liquid following centrifugation assayed for enzyme activity. Four identical batches were run in this set of experiments and the results are shown in the following table.

Table 6.

Batch no.	Filter paper activity	C ₁ -Cotton activity [Reducing sugar conc. after 24 hrs. hydrolysis of 50 mg cotton] (mg/ml)	C _x -activity [Reducing sugar conc. after 1/2 hr. hydrolysis of 1% CMC] (mg/ml)
1	1.97	2.91	2.37
2	2.31	2.52	2.40
3	1.87	3.23	3.14
4	2.04	2.37	2.42

From the above data of Filter Paper Activity measurements and comparison of these values with that obtained from the strain QM6a it indeed becomes apparent that the amount of enzyme excreted in 5 days is at least 3 times greater. Hence subsequent experiments for 2-stage C.S.T.R. enzyme production runs were carried out with the strain QM9414.

4.2.5. Two-stage C.S.T.R. runs for enzyme production

Growth of the fungus on soluble sugars from single stage C.S.T.R. runs described above in section 4.2.3 indicated that the maximum biomass productivity was obtained around a dilution rate (or specific growth rate) of 0.21 hr^{-1} . On insoluble substrates (pure spruce wood cellulose) however the maximum specific growth rate was to the order of 0.027 hr^{-1} or about an order of magnitude lower. Cellulase is known to be an inducible enzyme secreted in the medium only in the presence of an appropriate inducer like cellulose.

cellobiose, etc. From these observations 2-stage C. S. T. R. runs were planned; in the first stage the fungus was grown on soluble sugars and in the second stage the inducer in the form of pure spruce wood cellulose added for production of the enzyme. The liquid volume in the first stage was 500 ml, temperature 30° C, aeration at 0.5 V. V. M. and the feed operated at a dilution rate of 0.21 hr^{-1} for maximum cell productivity. No external pH control for this stage was maintained and the average pH of the effluent fluids from this state was 3.2. The second stage had a liquid volume between 4 and 10 liters and operated at 30° C and aeration rate of 0.5 V. V. M. pH of this stage was externally controlled at 4.8. The effluents of the first stage were directly transported to the second stage and the dilution rate was varied between 0.012 hr^{-1} to 0.026 hr^{-1} by varying the liquid volume. Pure spruce cellulose was added to this second stage through a disc type low rate solid feeder so that the incoming concentration was maintained between 10 mg/ml and 5 mg/ml. This was the only source of carbon in the second stage since at the operating conditions essentially all the sugars in the first stage were exhausted. When steady state was reached samples were taken from the second stage and assayed for enzyme activity.

Two sets of runs were made in this context; one with 0.5% and the other with 1.0% inlet dextrose concentration to the first stage. The rate of cellulose addition for these two cases was also 0.5% and 1.0% respectively. The enzyme activity measurements with varying dilution rate observations are shown in Figure 24. The maximum enzyme activities for the two cases were 0.7 and 1.3 Filter Paper activity respectively around a dilution rate of 0.2 hr^{-1} . Since the incoming biomass

concentration in the latter case was twice that of the former (4.4 mg/ml compared to 2.20 mg/ml) the doubling of secreted enzyme in the presence of the inducer was to be expected. In the neighborhood of 0.027 hr^{-1} dilution rate total washout was obtained; this corresponded to an average residence time of 37 hours. There is an inherent lag between the growth of the fungus in soluble sugar and subsequent production of the enzyme in presence of the inducer. Batch results obtained by Rosenbluth and Wilke (9) placed this lag around 40 hours for the culture of T. viride in the presence of 1% glucose and a subsequent sterile addition of 1% pure cellulose upon exhaustion of the initial sugar. Spot estimation of cellulose concentration was made in the effluent stream from the second stage to make sure that enzyme activity was not limited by inducer concentration.

Analysis of a 2-stage C.S.T.R. operation where a different substrate is added to the second stage for conversion to a desired product was presented by Herbert (10). This second substrate, as in the present case, did not support any growth in the given average residence time.

Let

- Z → concentration of the inducer
- X → biomass concentration
- p → concentration of enzyme produced
- t → elapsed time
- S → concentration of growth substrate (dextrose) in the first stage.
- Y → Yield constant ($\frac{\Delta X}{\Delta S}$) for the first stage.

Cell growth in the first stage $X_1 = Y(S_{in} - S_{ou})$
 $\approx Y S_{in}$ (for nearly total exhaustion
of growth substrate $S_{out} \ll S_{in}$).

The kinetics of resting cells for production of the enzyme was approx-
imated by a Michaelis-Menten type relation as reported in literature
(12) for certain steroid transformations

$$-\frac{dZ}{dt} = \frac{1}{Y_c} \frac{dP}{dt} = \frac{kx_1}{Y_c} \left(\frac{Z}{k_Z + Z} \right)$$

where k is a metabolic coefficient having the dimension of a velocity
constant (t^{-1}), $Y_c \rightarrow$ Yield Cost. $\left(\frac{\Delta P}{\Delta Z} \right)$ for enzyme production.

k_Z is the Michaelis constant of half speed concentration. In
general, $k_Z \ll Z$ and the above equation reduces to

$$-\frac{dZ}{dt} = \frac{1}{Y_c} \frac{dP}{dt} = kx_1/Y_c$$

or the reaction becomes zero order at constant x . If D is the dilution
rate then a balance of enzyme concentration over the second stage:

$$\frac{dP}{dt} = -DP + \left(\frac{dP}{dt} \right) \text{ production}$$

or

$$\frac{dP}{dt} = -DP + kx_1/Y_c$$

At steady state L.H.S. = 0

or
$$P = \frac{k X_1}{DY_c}$$

or
$$P = \frac{k Y S_{in}}{DY_c}$$

If the metabolic coefficient k is assumed to be a constant entity then for a given dilution rate D , P should be directly proportional to the resting biomass x_1 of $Y S_{in}$ and this indeed was the case with the experimental observations. What was particularly interesting though was the inverse relationship predicted between P and D for a given x_1 (assuming a constant k). The experimental values did not follow this behavior over the entire range of dilution rates tested. From dilution ratio of 0.02 hr^{-1} and upwards the main effect of increasing dilution rate (or decreasing residence time) was wash out as far as enzyme activity was concerned. Lowering the dilution rate beyond 0.02 hr^{-1} however did not produce the predicted increase in enzyme activity and a slow progressive decrease with decreasing dilution rate was observed.

To determine the reason for these observations samples from the second stage were assayed for insoluble protein content and one such set of readings for 5 mg/ml inlet glucose concentration to the first stage is shown in Fig. 24. The biomass concentration out of the first stage at a dilution rate of 0.21 hr^{-1} was 2.2 mg/ml corresponding to an insoluble fungal protein of 0.72 mg/ml . In the second stage, however, at dilution rates lower than 0.02 hr^{-1} the insoluble protein content decreased gradually from 0.72 mg/ml at a dilution rate of 0.02 hr^{-1} to 0.45 mg/ml at a dilution rate of 0.0125 hr^{-1} . Since there was no other source of carbon available to the cells during the time they resided in the second stage, an increase in residence time beyond a certain limit produced a gradual diminishing effect on the usual turn

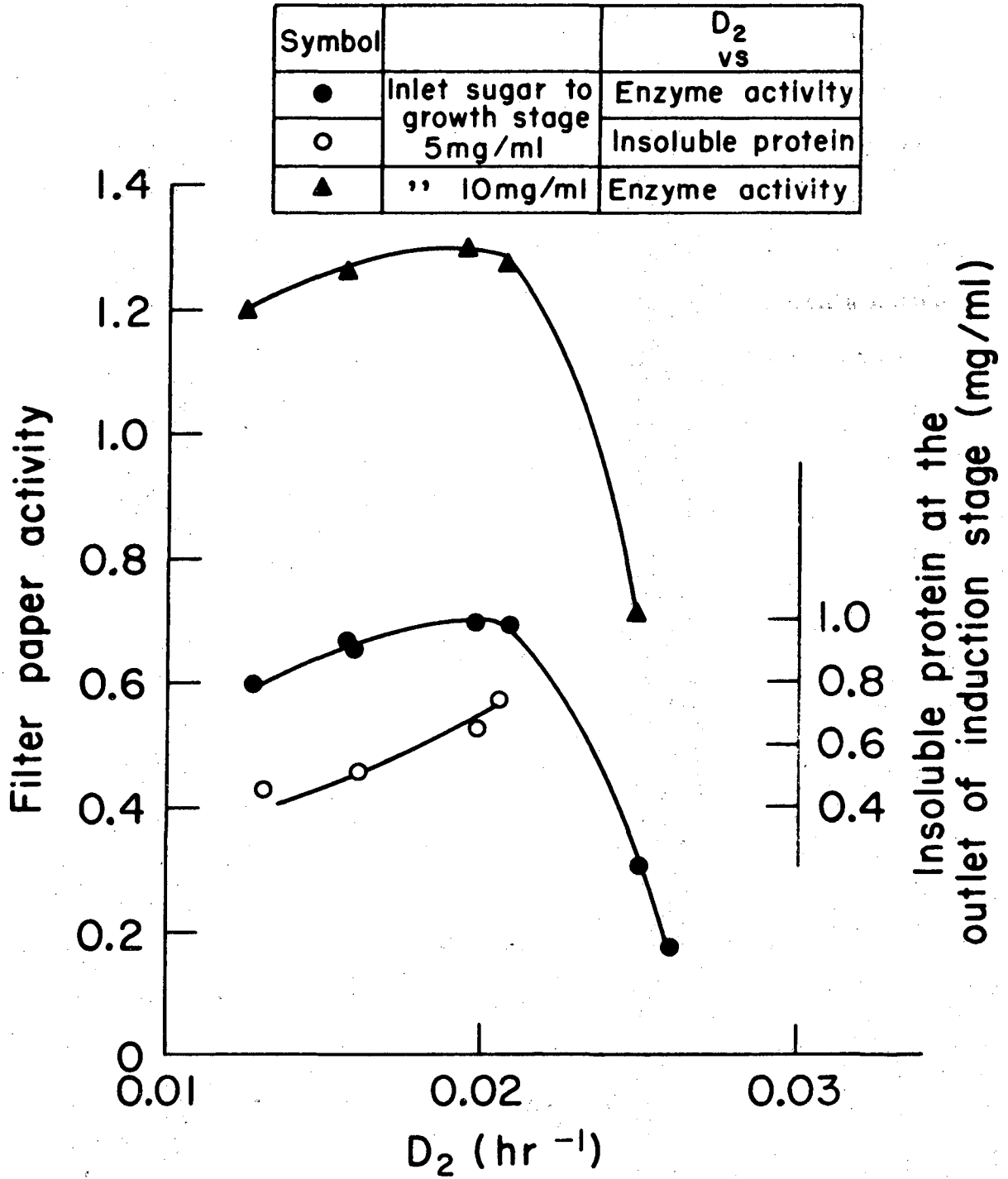

XBL 7310-4168

Fig. 24. CSTR operation of the enzyme induction stage
 $D_2 \rightarrow$ dilution rate.

over rate of proteins of normal healthy fungal biomass. This resulted in a decrease in the rate of excretion of secondary metabolites into the medium (decrease in metabolic coefficient k) corresponding to an equivalent decrease in cellulase activity.

A 2-state operation described above can very well be compared with a single stage C. S. T. R. operation for enzyme production. Mandels and Weber reported (2) a semi-continuous operation with 1% pure spruce wood cellulose to obtain an average enzyme productivity of 5.39×10^{-3} filter paper activity/ml x hr. The enzyme productivity for the present setup at 0.21 hr^{-1} dilution rate was 27.3×10^{-3} $\frac{\text{filter paper activity}}{\text{ml x hr}}$ utilizing 1% dextrose for growth and 1% pure cellulose for induction corresponding to an increase in productivity by a factor of 4.13.

4.2.6. Separation of Enzyme from Solids Following Enzyme Production

Filtration studies were made to determine the separation characteristics of the enzyme solution from the mycelium-cellulose mixture following enzyme production. Batch cultures of T. viride QM9414 on 1% dextrose as carbon source were grown in shake flasks at 30°C for 3 days resulting in total exhaustion of available substrate. This resulted in an average biomass concentration of 4.3 mg/ml corresponding to a yield factor of 0.43. Since filter aids are cellulose based solids various amounts of pure spruce wood cellulose (1:1, 5:1, 10:1) were added to this mycelium culture and the mixture passed through a filter consisting of a Millipore holder containing a 9.6 cm^2 disc of Whatman Filter Paper No. 42. Filtrate flows were determined at

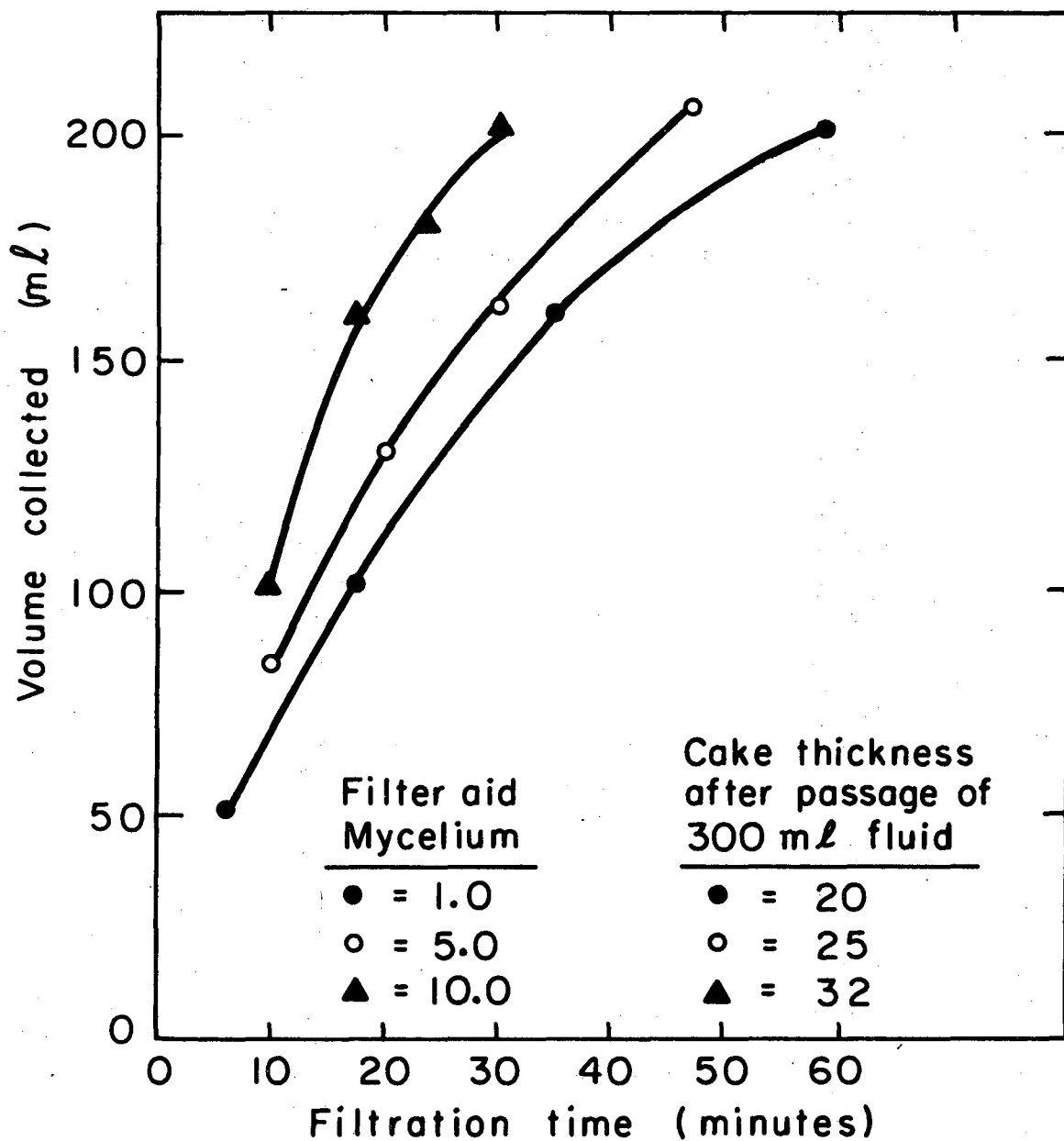

XBL 7310-4325

Fig. 25. Filtration results following enzyme production. Filtration area 9.6 cm².

various times under an average vacuum of 17" Hg and the results are shown in Fig. 25.

4.3. Enzymatic Hydrolysis of Newsprint

For hydrolysis experiments issues of the Wall Street Journal published over the period November 1972 to June 1973 utilized as substrate. This was done because of literature report of its cellulose content by Updegraff (13) and its ready availability as a standardized substrate material. Wall Street Journal copies were shredded in a paper shredder and then milled in a pebble mill (grinding medium porcelain cylinders of size 1 × 2 cm) for 48 hours. The material was then sieved to obtain -200 mesh fraction, the coarser particles were recycled back for further milling. Effect of heating the substrate was investigated for two specific instances—before milling and after milling. For both cases the substrate material was heat treated inside a 170° C stationary oven for 30 minutes. No effort was made to remove the ink or other inert ingredients present in the paper. The concentration of the ground newsprint in the enzyme solution was maintained at 10% unless otherwise stated. The temperature of hydrolysis was 50° C and pH 4.8. The enzyme solution was obtained from the two stage enzyme production system described previously under section 4.2. This solution was utilized as is or concentrated by acetone precipitation (acetone: enzyme solution = 3:1 V/V) and redissolving the precipitated protein in appropriate volumes of citrate buffer (pH 4.8).

Figure 26 shows the initial rates of hydrolysis with enzyme of 2.87 filter paper activity. Heating after milling resulted in a

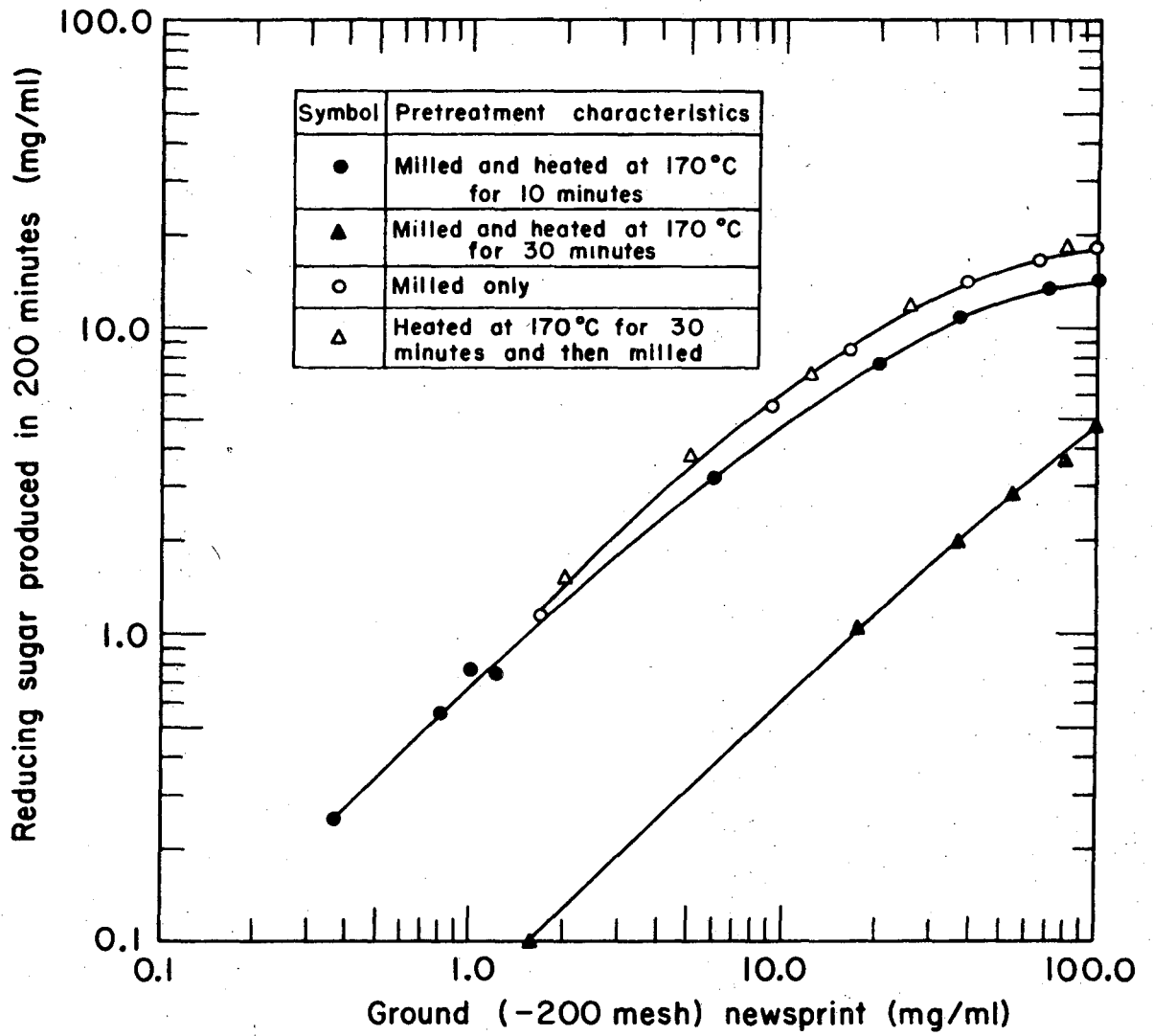

XBL7310-4167

Fig. 26. Initial rate of hydrolysis with enzyme of 2.87 filter paper activity.

progressively slower rate of hydrolysis. A period of 30 minutes of heating following milling resulted in 59% decrease of initial rate for a 10% solid suspension. These observations substantiated the findings of Ghosh and Kostic (14), the inhibitory effects being a direct result of drying out of ground fibers. Since one mole of glucose is formed according to the following schematic representation of

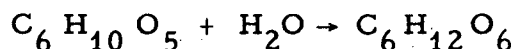

decrease in water uptake capacity of the interstitial spaces in the fiber matrix would hinder the enzymatic degradative process. Heating before milling did not result in any appreciable difference in hydrolysis rates for the particular substrate studied. Increasing substrate concentration resulted in a proportional increase of reducing sugars produced. This increase in rate with increasing substrate concentration leveled off near 10% solids concentration.

Figure 27 shows hydrolysis experiments conducted with various enzyme activities, the higher activities being obtained by concentration of lower activity samples as described before. In all experiments the liquid volume was 500 ml; samples were drawn at regular intervals, centrifuged to obtain the clear supernatant and assayed for reducing sugar. For a given hydrolysis time higher enzyme activity resulted in a greater degree of hydrolysis as would be expected. During concentration of the indigenous enzyme sample it was noticed that around a concentration factor of 4.0 it was difficult to redissolve the protein back in solution since saturation point for the protein was nearly reached. This indirectly fixed the upper limit of enzyme activity for

the study. 61% of the substrate consisted of pure cellulose and hence % hydrolysis for these cases can be tabulated as follows:

<u>Enzyme</u>	<u>Hydrolysis at Various Times</u>		
	<u>20 hr.</u>	<u>30 hr.</u>	<u>40 hr.</u>
1.0 F.P.	39.14 %	50.21 %	57.60 %
2.72 F.P.	64.98 %	75.32 %	81.97 %
3.25 F.P.	73.11 %	81.97 %	88.61 %
4.26 F.P.	77.54 %	85.66 %	90.83 %
4.41 F.P.	81.97 %	89.35 %	94.52 %

The % hydrolysis values obviously correlate to the cellulose content (61%) of the substrate; the non-cellulosic materials, namely lignin and hemicellulose, remain as inert ingredients as far as the cellulase enzyme is concerned. Hence the total solids present in the hydrolysis system can be computed as follows:

At time 40 hr., % conversion of cellulose for enzyme activity

$$2.72 = 81.97\%$$

$$\begin{aligned} \text{cellulose unreacted} &= (61 (1-0.8197)) \text{ mg/ml} \\ &= 10.998 \text{ mg/ml} \approx 11.0 \text{ mg/ml} \end{aligned}$$

$$\begin{aligned} \text{total solids in the system at 40 hrs.} &= 39 + 11 \\ &= 50 \text{ mg/ml} \end{aligned}$$

These spent solids from the above example were harvested by centrifugation, washed 5 times with buffer to remove traces of adsorbed enzyme and dried in a 90° C oven overnight. Various amounts of this dried sample were contacted with 100 ml of fresh enzyme of 2.72 filter paper activity and the initial rates of hydrolysis at 50° C measured.

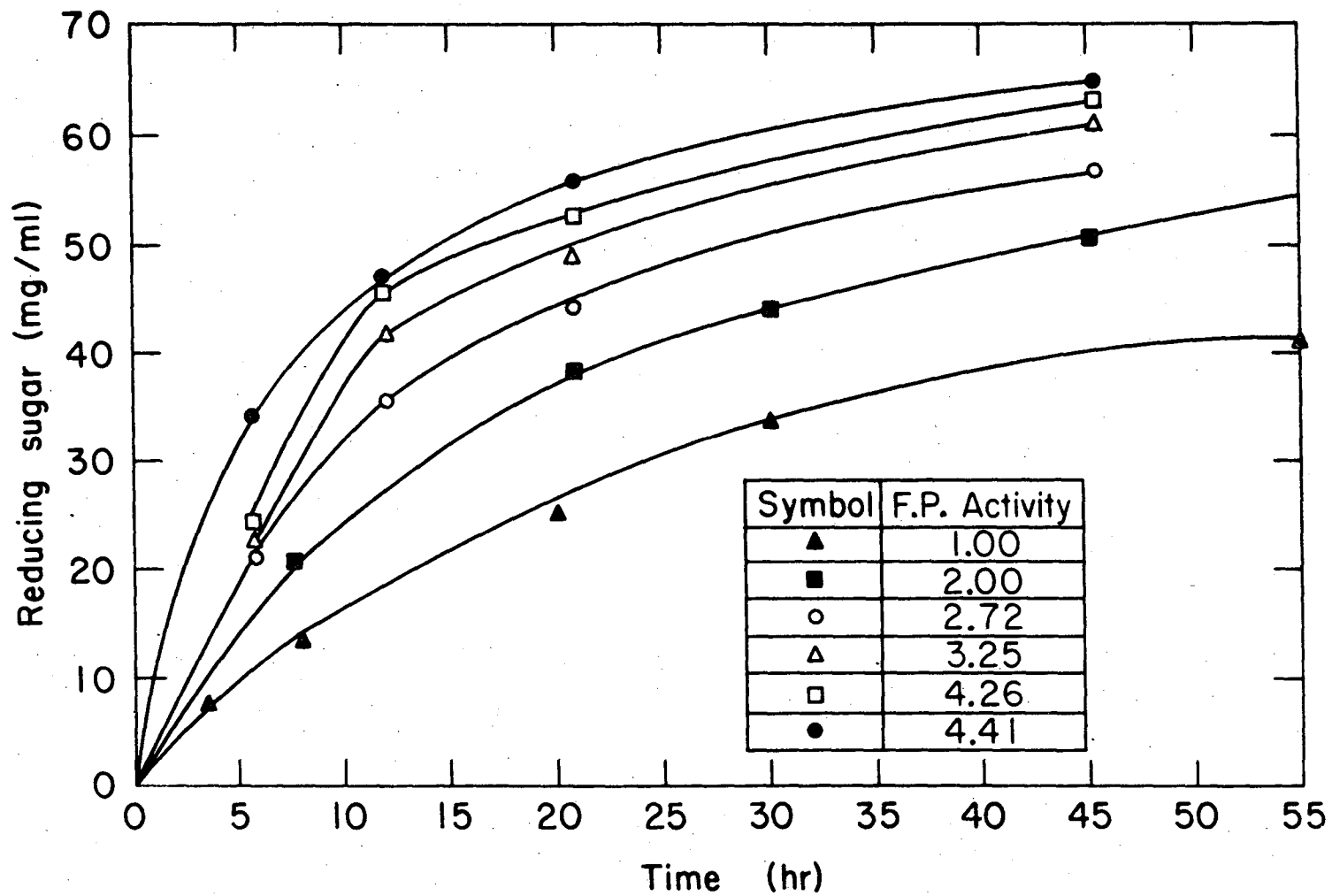
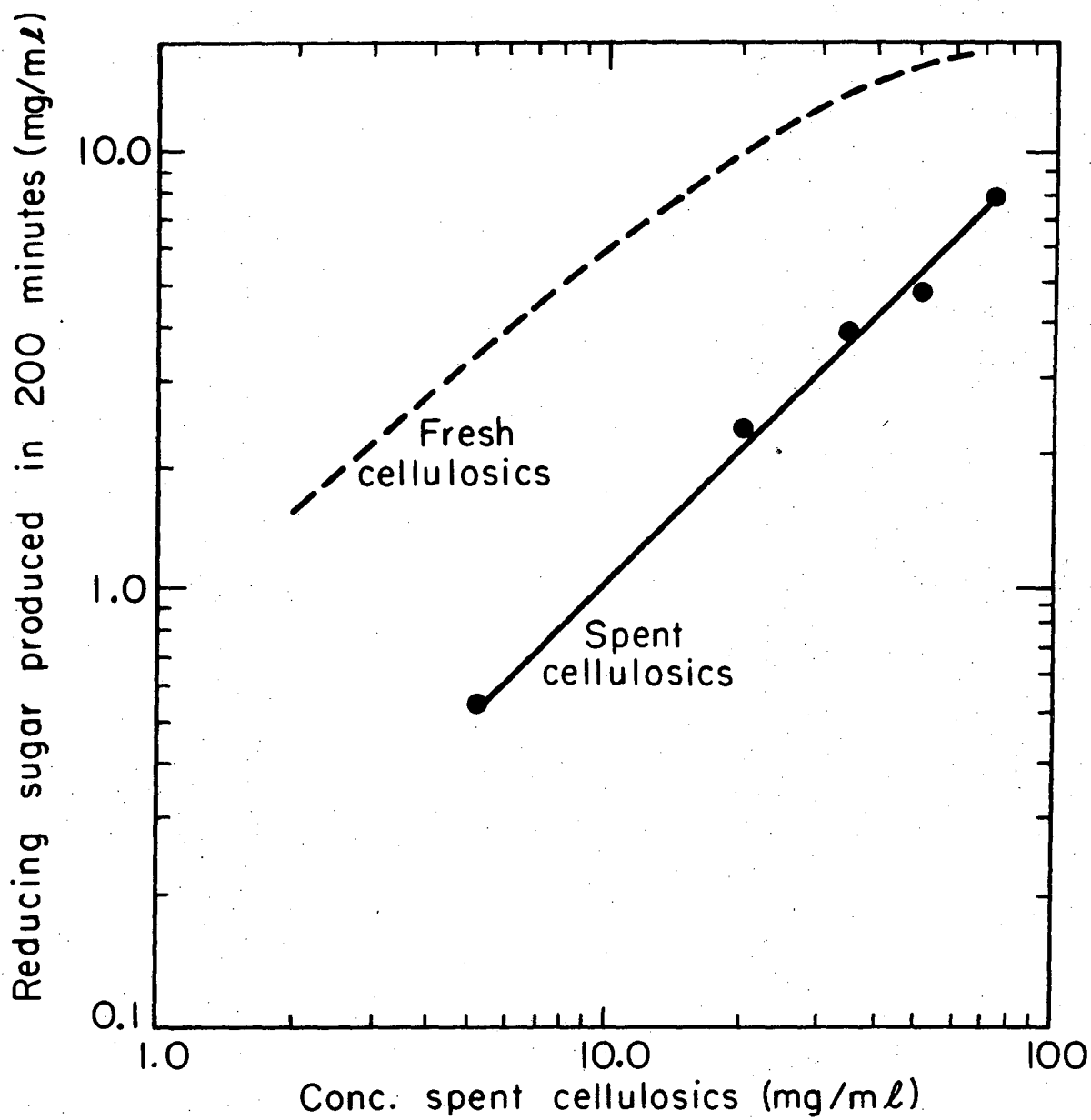

Fig. 27. Hydrolysis of 10% ball milled (-200 mesh) newsprint.

The results are shown in Fig. 28. For adequate comparison the initial rates with fresh substrate under similar conditions are shown by the dotted line in the same graph. A sizeable decrease in hydrolytic breakdown was apparent for the spent cellulosic material. This could be attributed to the increase in non-cellulosics/pure cellulose ratio from 0.64 to 3.55. Lignin and hemicellulose physically hinder the enzyme molecule from coming in contact with the cellulose chain. An increase in their proportion with respect to pure cellulose would obviously make it more difficult for the enzyme molecule to penetrate the solid matrix and physically come in contact with a β 1, -4 glucosidic linkage. This probably is the main reason why the rate of hydrolysis for the milled newsprint decreased with time as shown in the previous Figure (27). As more and more cellulose got converted to reducing sugars it was more and more difficult for the free enzyme to contact the unreacted cellulose due to physical hindrance of noncellulosic materials.

Effect of grinding upon the extent of hydrolysis was subsequently investigated with various enzyme activities as shown in Figure 29. The substrate used was pure cellulose in the form of Whatman Filter Paper #1 at a concentration of 2.5%. The substrate was in the form of a 1 cm \times 6 cm strip and hence unground. The pH was 4.8 and temperature 50° C as in previous hydrolysis experiments. Percent hydrolysis values with time obtained from the graph are tabulated below.



XBL7310 - 4324

Fig. 28. Initial rate of hydrolysis as a function of spent cellulosic conc.

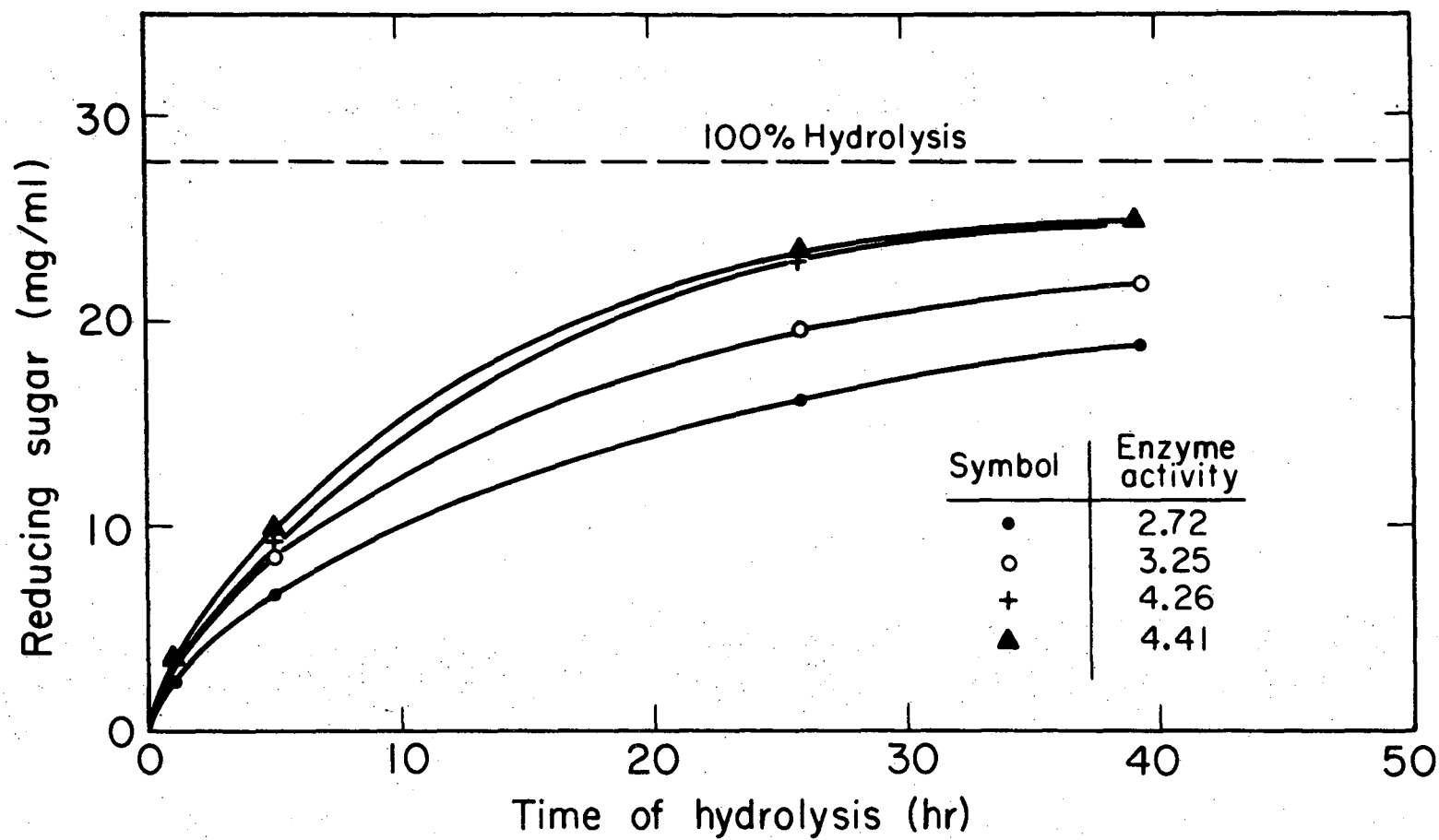

-109-

XBL7310-4233

Fig. 29. Hydrolysis of unground cellulose with acetone precipitated enzyme.

Enzyme activity	% Hydrolysis at Various Times		
	20 hr.	30 hr.	40 hr.
2.72 F.P.	51.35 %	62.16 %	67.57 %
3.25 F.P.	63.06 %	73.87 %	78.38 %
4.26 F.P.	47.77 %	85.59 %	---
4.41 F.P.	77.48 %	86.49 %	89.19 %

A comparison of the above values with those with milled newsprint (previous table) indicates that although the substrate in this case was pure cellulose % hydrolysis was consistently lower. Absence of physical hindrance from non-cellulosics for this case was overcome by the lack of adequate surface area resulting in an overall decrease of hydrolytic breakdown. This suggests that if the unground substrate was newsprint the % hydrolysis values would be still lower since the sum total of the above two effects would be cumulative.

4.4. Enzyme Recovery and Reuse

Recovery of enzyme from the effluent liquid following hydrolysis was investigated by adsorption on freshly ground (-200 mesh) newsprint at 50° C. Various amounts of the ground newsprint were contacted with enzyme of 2.85 Filter Paper activity and the amount of original activity in free solution measured after the adsorption equilibrium was attained. Figure 30 depicts approach to such equilibrium for a solids concentration of 1 mg/ml. After a contact time of 120 minutes the enzyme activity in the free solution remained constant. For all subsequent experiments a contact time of 200 minutes

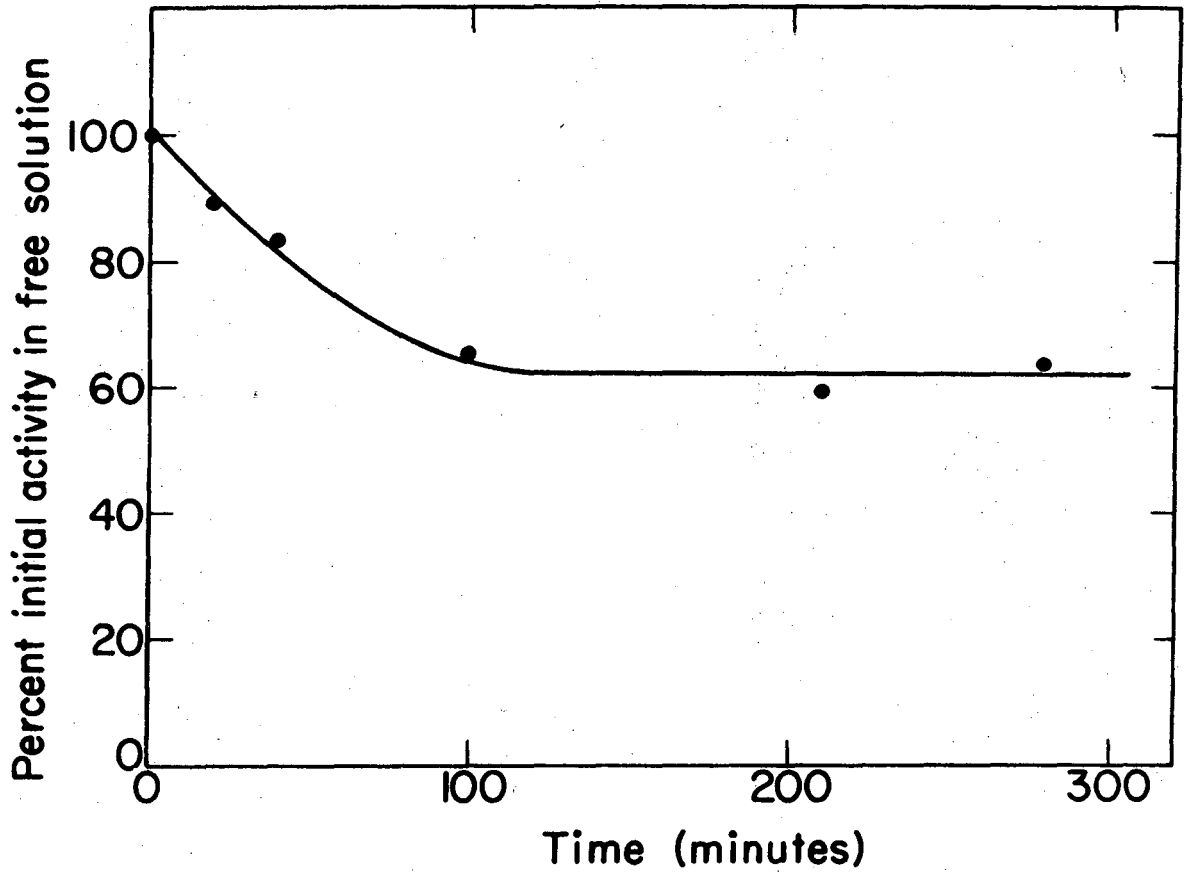

XBL7310-4165

Fig. 30. Approach to adsorption equilibrium at 50° C. Solids content: 1 mg/ml -200 mesh ball milled newspaper; enzyme activity: 2.85 filter paper act.

was maintained before measuring the activity in the free solution. This assured positively an equilibrium situation between the solid and the liquid phase and Figure 31 depicts such measurements with various concentrations of newsprint. C_1 and C_x activities were adsorbed in different amounts, both showing quite high adsorption for the substrate. At very low concentration of solids ($< 1.6\%$) C_x activity was not adsorbed, all of it remaining in solution. C_1 activity in this range of solid concentrations was constant around 81% of its initial activity in free solution. Preferential adsorption of C_1 activity at low solid concentration corroborates the 2 step enzyme action mechanism postulated by Reese et al. (3). Since all of the C_x activity in this region was in the liquid phase the initial attack on the insoluble substrate had to be due to the 19% of the C_1 activity adsorbed on the solid matrix. Increase in solids concentration beyond 1.6% resulted in increased adsorption of C_1 and C_x activity and for 10% solids these values were 60% and 84% respectively.

The spent cellulosic solids following hydrolysis had a different non-cellulosic/pure cellulose ratio compared to the freshly ground newsprint. The adsorption equilibrium for the enzyme with the effluent solids from the hydrolyzer was determined in the following experiment. A 10% solids suspension in contact with enzyme of 2.72 filter paper activity for 40 hours produced 82% conversion based on initial cellulose content. This was the same experiment described before under Section 4.3. The solids were separated by centrifugation, washed five times with equal volume of citrate buffer to remove all

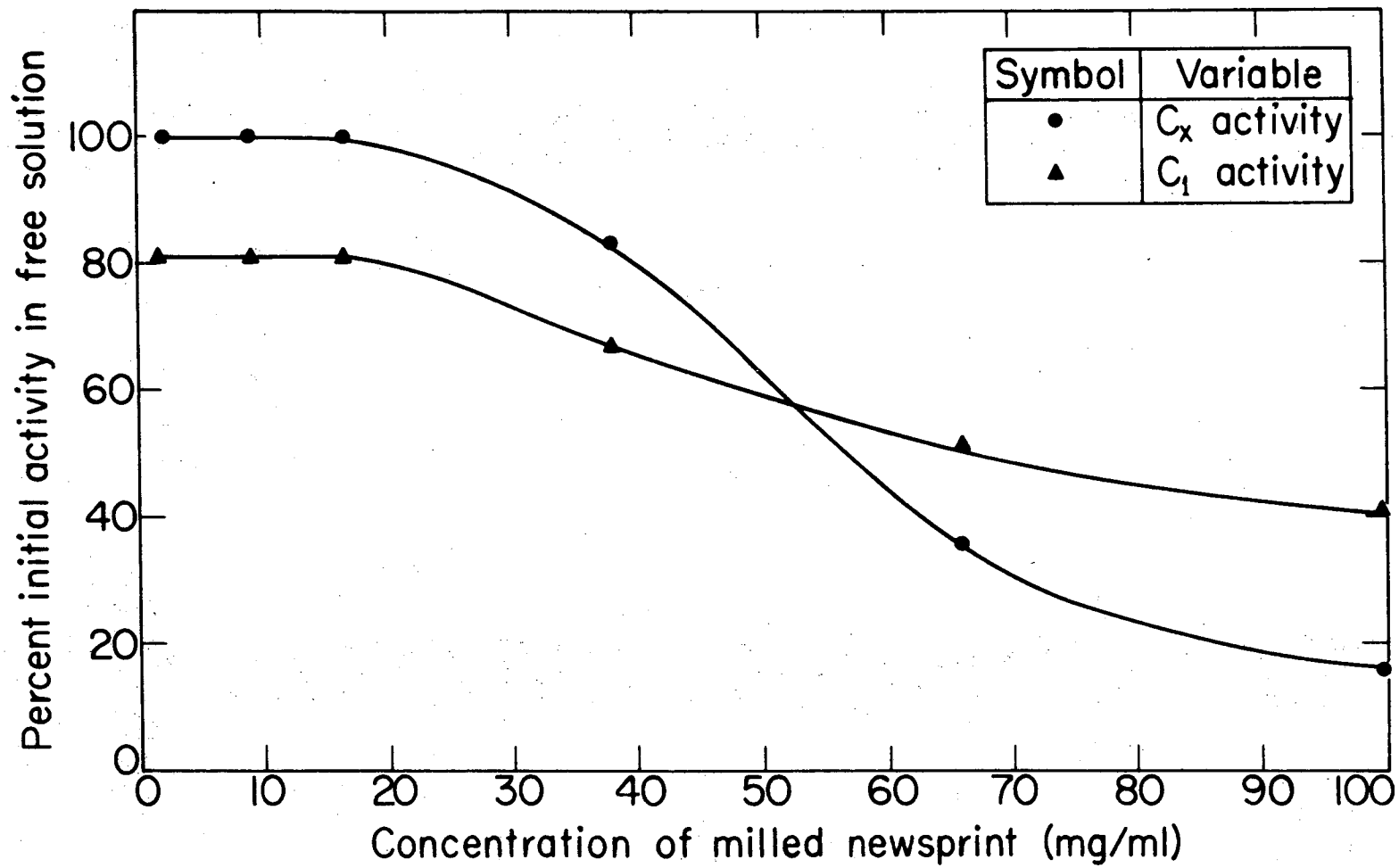

-113-

XBL7310-4166

Fig. 31. Adsorption equilibrium at 50° C.

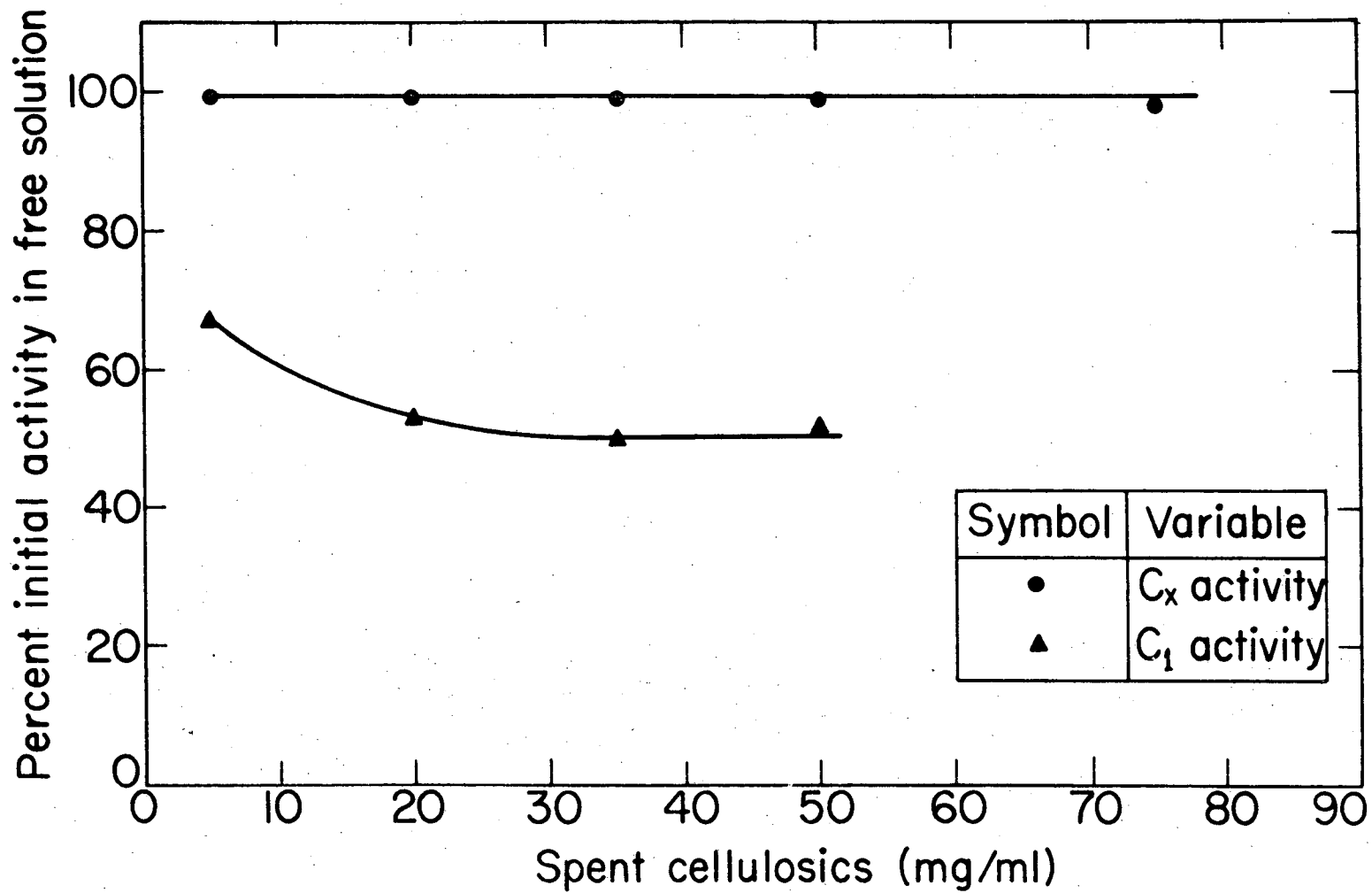

XBL7310-4164

Fig. 32. Adsorption equilibrium between fresh enzyme (F.P. 2.72) spent cellulose.

traces of the adsorbed enzyme, dried overnight in a 90° C oven and then contacted with 100 ml of fresh enzyme of 2.72 filter paper activity. Various amounts of the spent cellulose were contacted with the enzyme solution at 50° C for 200 minutes and the enzyme activity in free solution measured. Results are shown in Figure 32. Unlike freshly ground newsprint all C_x activity remained in free solution in this case. About 49% of C_1 activity was adsorbed by a 3% solid suspension. Further increase in solids concentration did not produce any appreciable increase in C_1 adsorption.

Experiments were conducted with the idea of recovering this 49% adsorbed C_1 activity. The solids from the previous experiments were separated by centrifugation and the above process repeated for the second and third wash. The results obtained are shown below.

Spent Solids (82% Cellulose Converted) Concentration 50 mg/ml

Initial C_1 (O.D.)	Equilibrium C_1 in free solution in contact with spent cellulose (O.D.)	Equilibrium C_1 in free solution of first wash. (O.D.)	Equilibrium C_1 in free solution of second wash. (O.D.)	Equilibrium C_1 in free solution of third wash. (O.D.)
0.58	0.296	0.123	0.070	0.040

Hence the equilibrium distribution of C_1 activity during washing is as follows:

	First Wash	Second Wash	Third Wash
Y ($\frac{\text{enzyme units}}{\text{ml liquid}}$)	0.598	0.341	0.192
X ($\frac{\text{enzyme units}}{\text{gm solid}}$)	15.12	8.47	4.74
K (partition Co-eff	0.0396	0.0403	0.0406

Schematically the experiments conducted for recovery of the adsorbed enzyme activity from the solids can be designated as follows:

Let V be the volume

Initial C_1 activity (O.D. = 0.58) be arbitrarily assigned a value of 100.

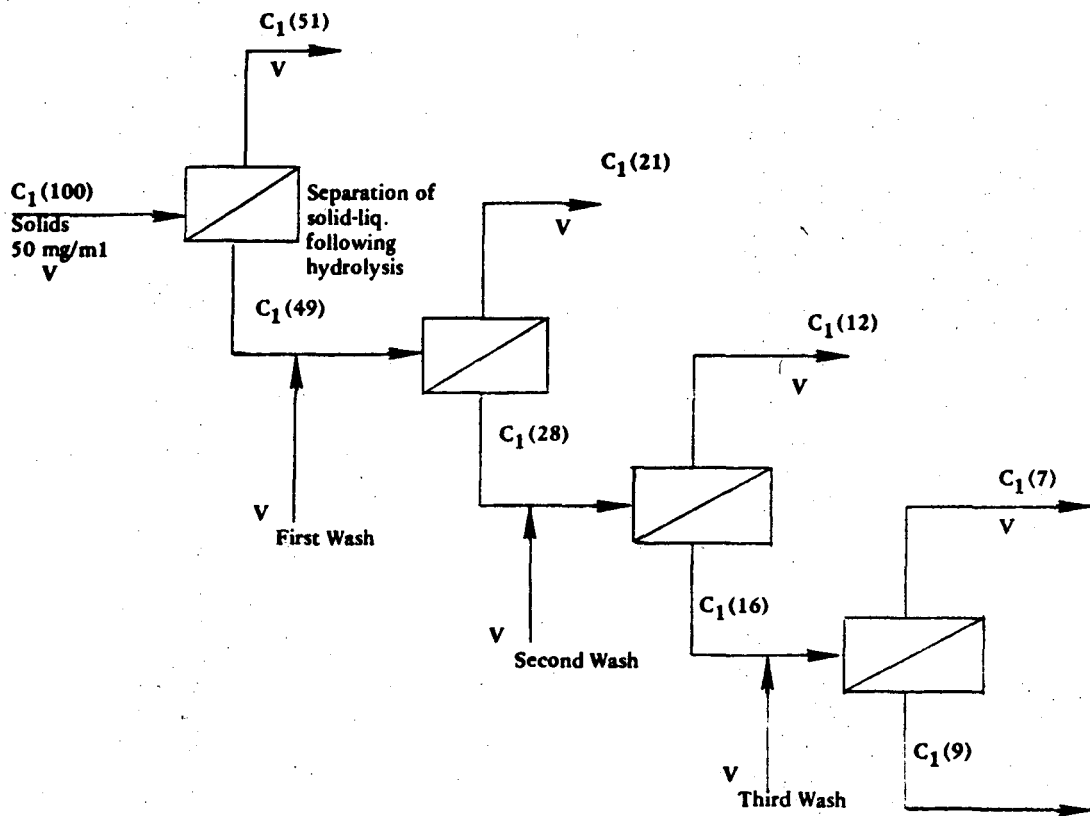

Hence the consecutive washing in 3 stages resulted in an overall recovery of $21 + 12 + 7 = 40\%$ of the original C_1 activity. Since only 40% of the original C_1 activity was adsorbed on the effluent solids the above corresponded to an 81.5% recovery of the adsorbed enzyme. The accompanying dilution effect due to a total wash volume of 3V has to be taken into account in this respect. Finally concentration and dilution effects on enzyme activity were determined. Enzyme solution of filter paper activity 2.85 and 1.2 mg/ml protein were used as the starting material. 10 ml of the enzyme solution were added to 30 ml of acetone and held for 1/2 hour at room temperature to facilitate the precipitation of enzyme protein. The sample was then centrifuged at 3000 rpm for 5 minutes, the supernatant discarded and the precipitate redissolved in appropriate amounts of citrate buffer. The enzyme activity of this redissolved protein was then determined by the standard method. The results are shown in Fig. 33. The general trend in data is to be expected as the residual substrate offers increasing resistance towards enzyme action unlike the traditional homogeneous system where both the enzyme and the substrate are in the liquid phase. The upper limit of enzyme activity was determined by solubility problems; around an enzyme activity of 4.5 F. P. redissolving the protein became a difficult task and portion of the precipitated protein did not go into solution.

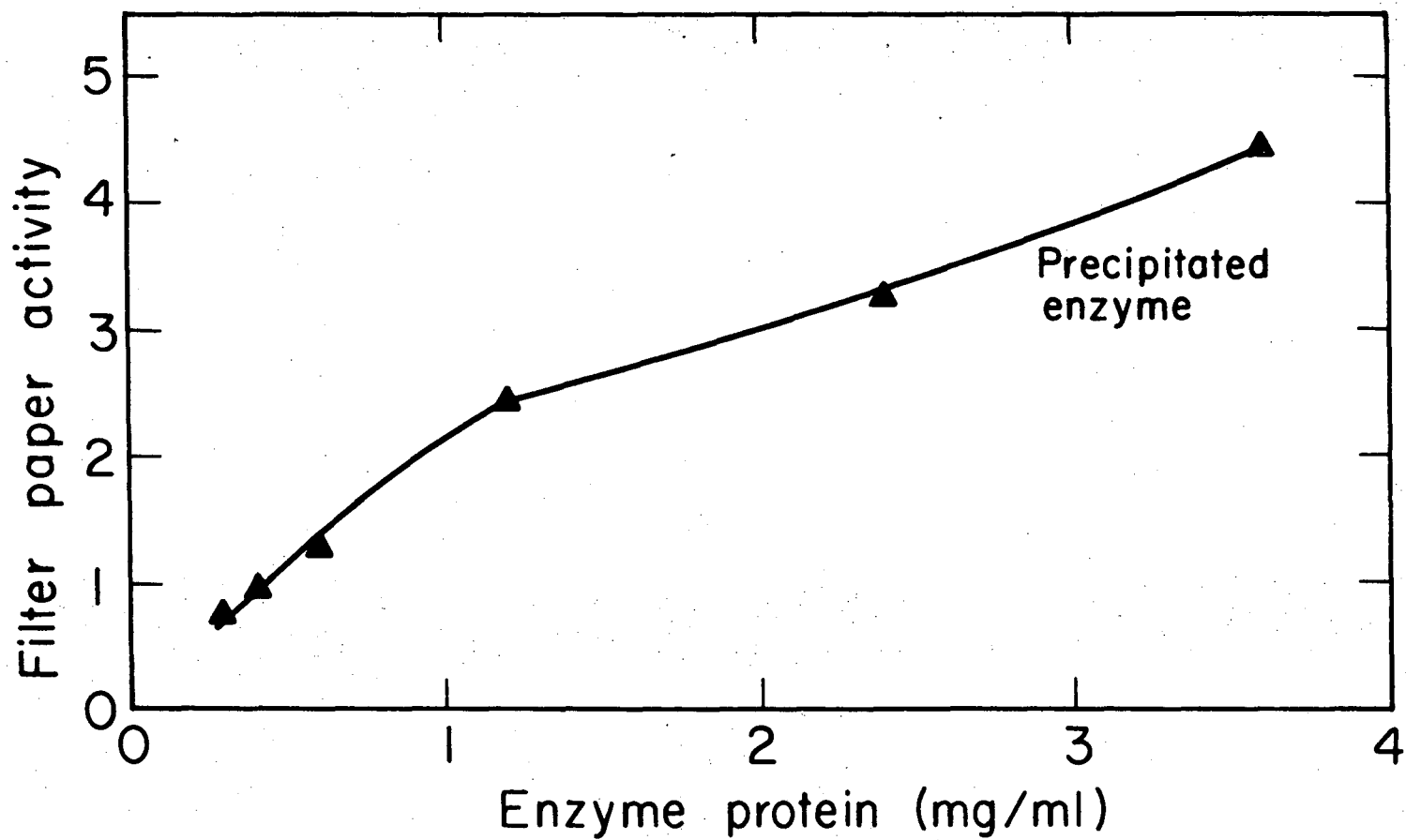

-119-

XBL 7310- 4234

Fig. 33. Concentration and dilution effects on enzyme activity.

Literature Cited in Chapter 4

1. Mandels, M., J. Weber, R. Parizek, *Appl. Microbiol.*, 21(1) 152 (1971).
2. Mandels, M. and J. Weber, *Adv. in Chem. Ser.*, 95, 391 (1969).
3. Reese, E. T., R. G. H. Siu, H. S. Levinson, *J. Bacteriol.* 59, 485 (1950).
4. Selby, K. and C. C. Maitland, *Biochem. J.*, 104, 716 (1967).
5. Nisizawa, K., T. Tomita, T. Kanada, H. Suzuki, K. Wakabayashi, *Fermentation Technology Today* (G. Terui, ed.) 719, 1972.
6. Mandels, M., E. T. Reese, *J. Bacteriol.*, 72, 269 (1957).
7. Mandels, M., E. T. Reese, *J. Bacteriol.*, 79, 816 (1960).
8. Mandels, M., E. T. Reese, *J. Bacteriol.*, 83, 400 (1962).
9. Rosenbluth, R. F., C. R. Wilke, SERL Report No. 70-9, College of Engineering and School of Public Health, U. C., Berkeley (1970).
10. Herbert, D., *Cont. Culture of Microorganisms*, S. C. I. Monograph No. 12, 80 (1961).
11. Brown, D. E., *Methods in Microbiology*, p. 137, Academic Press New York, 1970.
12. Stephenson, M., *Bacterial Metabolism*, Longmans Publishers, London (1948).
13. Updegraff, D. M., *Anal. Biochem.*, 32, 420 (1969).
14. Ghose, T. K., J. A. Kostick, *Adv. in Chem. Series*, 95, 415 (1969).

5. PROCESS DESIGN AND ECONOMIC EVALUATION

5.1. Design Basis

Based on experimental observations of Chapter 4 a process design has been proposed for hydrolysis of waste paper utilizing fungal enzyme cellulose from Trichoderma viride QM9414. Process conditions, reaction rates and separation characteristics are based on the present work and the basis of the process design is as follows:

a) The process is designed to treat 885 tons/day of waste paper containing 6% moisture. Cellulose content of the newprint is 61%, i. e. the same as that of the newprint utilized for experiments described in Chapter 4. The substrate is shredded and ground to -200 mesh size before being utilized for hydrolysis.

b) Solid concentration in the hydrolysis vessel is 10%. The hydrolysis temperature is maintained at 50°C and pH at 4.8. For an enzyme activity of 2.7 F. P. a residence time of 40 hours is maintained, this corresponds to 82% conversion based on experimental results of Chapter 4 (Figure 27).

c) Effluents from the hydrolyzer are passed through a filter to remove the unreacted solids from the enzyme and glucose solution. According to adsorption equilibrium values described in Figure 32 of Chapter 4 only 51% of the hydrolyzer enzyme activity remains in the liquid phase after filtration, the rest being adsorbed on spent solids. To recover the adsorbed enzyme the filtered solids are washed in a series of countercurrent mixer-settlers and the wash water fed back to the hydrolysis vessel. The enzyme activity in the liquid phase on the other

hand is recovered by countercurrent adsorption on the incoming fresh solid feed to the hydrolysis stage. Detailed calculations shown in Appendix A indicate that 84.6% of the original enzyme activity can be recovered through the proposed scheme.

d) Make up enzyme is produced at 1.3 F. P. activity by culture of T. viride QM9414 in a two stage process. The enzyme protein is precipitated by addition of acetone (solvent:liquid = 3:1 v/v) to the culture broth following filtration to remove the mycelium. The enzyme precipitate following filtration is fed to the hydrolyzer. Acetone is recovered from the filtrate by distillation.

e) The spent solids from the hydrolyzer following washing are utilized as fuel for the reboiler furnace to the distillation column and for steam/power generation.

5.2. Description of the process

The flow sheet of the process is shown in Figure 34. Detailed calculations for sizing the process equipments and assigning numerical values to the different flow streams are shown in Appendix A. Only the summary of these calculations will be presented here in relationship to the flow sheet. 885 tons/day of waste paper (6% moisture, 61% cellulose) are shredded in paper shredders (G_1) and ground in hammermills (G_2) to yield -200 mesh particle size. The ground waste is contacted countercurrently in five mixer-filter states with filtrate solution from the hydrolysis section and then conveyed to the hydrolysis Section (H) consisting of 5 agitated cylindrical concrete digesters each with volume 5.54×10^4 gallons and power input of 260 HP. These concrete digesters

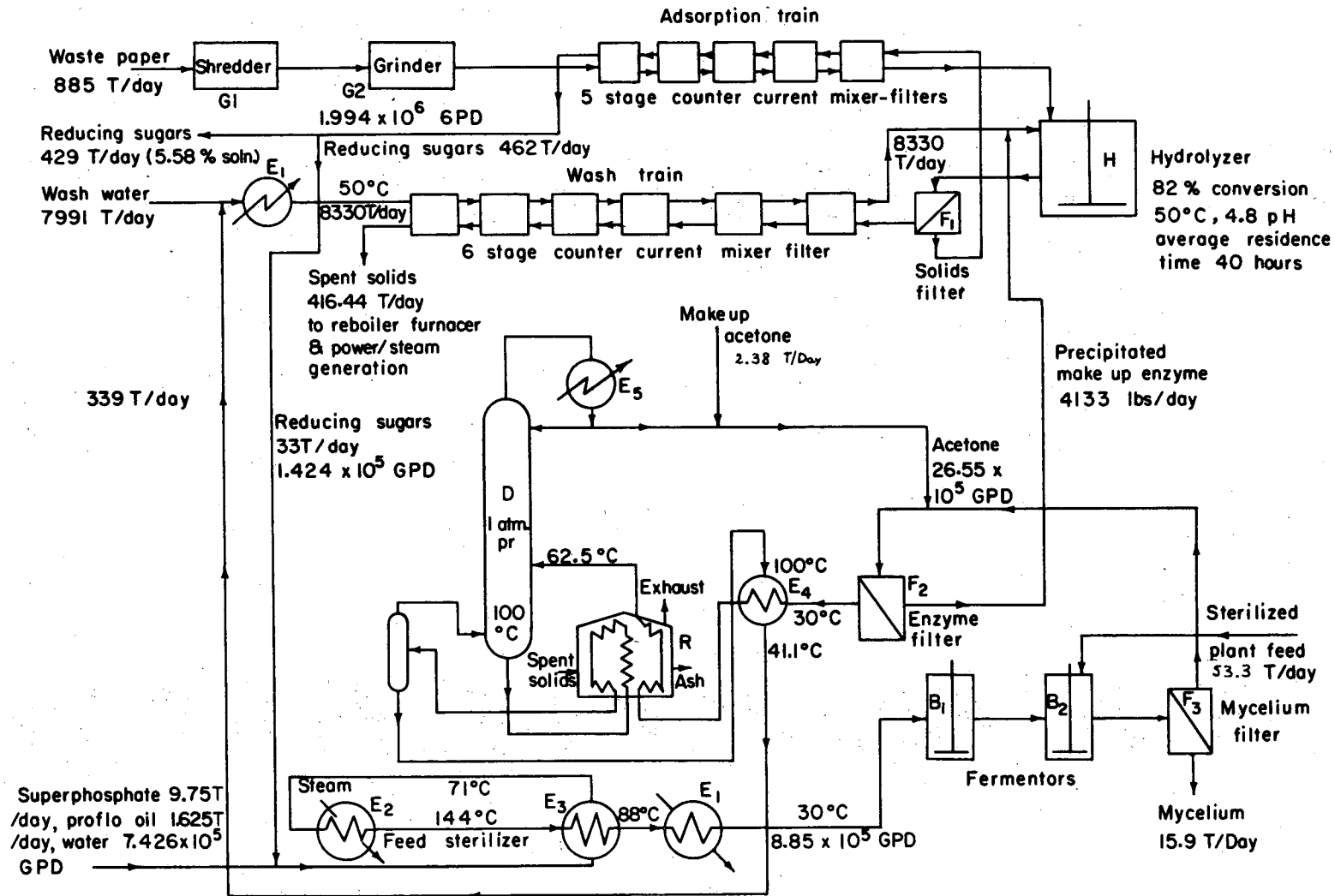

XBL7310-4385

Fig. 34. Flow sheet of the process.

are of the type used in solid waste treatment in sanitary engineering. The average reaction time of the cellulosic solids at 2.7 F. P. enzyme activity, 50°C temperature and PH 4.8 is 40 hours corresponding to a cellulose conversion of 82%. Following hydrolysis the effluents are filtered in a vacuum drum filter (F_1) to separate out the liquid and solid phase. (F_1) corresponds to one vacuum drum filter with filtration area of 1380 ft². The liquid stream following filtration enters the adsorption train as noted above to recover the enzyme in the liquid phase. Each adsorption stage corresponds to a mixing tank of volume 18.5×10^4 gallons and a vacuum drum filter of filtration area 1380 ft². The cellulosic solids with the recovered enzyme protein adsorbed on them are fed to the hydrolysis vessels. The liquid stream out of this adsorption train at 1.994×10^6 GPD containing 462 tons/day of reducing sugar is the product stream of this process. A part of this stream (1.424×10^5 GPD) is utilized in the enzyme make-up section for the growth of the fungus resulting in a net product output of 429 tons/day of reducing sugars as 5.58% solution.

The filtered solids from the hydrolyzers enter the wash train for recovery of the adsorbed enzyme by washing with process water (8330 tons/day) at PH 4.8 in 6 countercurrent stages. Each stage corresponds to a mixing tank of volume 18.5×10^4 gallons and a vacuum drum filter of filtration area 1380 ft². The liquid stream (8330 tons/day) is fed to the hydrolyzers and the spent solids containing 1 lb H₂O/lb dry cake (416.44 tons/day) are used as the source of fuel for the reboiler-furnace (R) and for steam/power generation. The wash water is heated from 77°F to 122°F in the heat exchangers

E_1 (total heat transfer area 2544 ft^2) by the make-up enzyme stream (8.85×10^5 GPD) in cooling it down from 191°F to 86°F . The overall enzyme recovery in the adsorption and wash train is 84.6% resulting in a make-up enzyme requirement of 15.40% of the total supplied to the hydrolysis section. The make-up enzyme is produced at 1.3 F. P. activity in fermentors (B_1) and (B_2). These are agitated stainless steel reaction vessels with liquid temperature at 30°C . The liquid volumetric flow rate is 8.85×10^5 GPD. (B_1) corresponds to 5 mycelium growth fermentors each with volume 4.08×10^4 gallons and 4 HP agitator motor. (B_2) corresponds to 5 enzyme induction fermentors each with volume 4.08×10^5 gallons and 100 HP agitator motor. The feed to the fermentors is sterilized in E_1 , E_2 and E_3 heat exchangers. In heat exchanger E_2 (heat transfer area 970 ft^2) the feed is heated from 160°F to 291°F by condensing steam at 120 psig. Heat exchanger E_3 (area 780 ft^2) heat the raw medium from 60°F at 160°F using process liquid exiting from exchanger E_2 as the heating medium. Heat exchangers E_1 (area 2545 ft^2) cools the sterile medium from 191°F to 86°F by heating the wash water to reaction temperature of 50°C . Following enzyme production mycelium solids are separated in pressure filter F_3 (filtration area 743 ft^2) and to the liquid stream (8.85×10^5 GPS) solvent acetone to the amount 26.55×10^5 GPD (3:1 v. v) is added for protein precipitation. The precipitated enzyme is separated by plate and frame pressure filters F_2 (total filtration area 7060 ft^2) and fed into the hydrolyzers. The liquid stream is utilized for solvent recovery by distillation in the column D (sieve plate column, 9.04 ft diameter, 23 sieve trays) to recover 99.99% of the acetone from the top of the column with the male

fraction of 0.9. The column bottoms are cooled from 212°F to 106°F in preheating the feed in the heat exchangers E_4 (area 1586 ft²) from 86°F to 120°F. The feed is further heated in the reboiler furnace R to a temperature of 144.5°F (62.5°C) before its entry to the distillation column. Reboiler furnaces R have a total heat duty of $157 \times 10^6 \frac{\text{BTU}}{\text{hr}}$, which is supplied by combustion of spent solids from the wash train. E_5 (heat transfer area 17,750 ft²) condenses the acetone vapor from the distillation column. Make-up acetone in the amount of 2.38 T/day is added to the liquid stream from the column top before being reused for solvent precipitation. Column bottoms at 339 T/day are recycled back to the wash water stream in the wash train.

Major items of process equipments with their capacity and purchased cost (sources in Appendix A) are shown in Table 7.

5.3. Energy requirement for the process

Major energy inputs to the process are three-fold (1) heat duty of the reboiler-furnace during solvent recovery (2) steam generation for sterilization of fermentor feed and (3) electrical power input to the major processing steps. The detailed calculations are shown in Appendix A and only a brief summary of these values will be mentioned here. Heat duty of the reboiler furnace is $223.40 \times 10^6 \frac{\text{BTU}}{\text{hr}}$, the steam generation plant energy input is $50.37 \times 10^6 \frac{\text{BTU}}{\text{hr}}$ and the electrical power input to the major processing steps is 4602.45 HP summarized in Table 8.

TABLE 7. Major Items of Equipment

Item	Description of each unit	No. of units	Cost/unit	Total purchased cost
Shredder (G ₁)	Welded steel construction, direct connected 75 HP, 3600 RPM motor, shaft mounted blower, air system with cyclone, capacity 5000-8000 lb/hr	10	\$ 22,000	\$ 220,000
Hammermill (G ₂)	Welded steel construction, direct connected 90 HP 3600 RPM motor, air system with cyclone, capacity 5000-800 lb/hr	10	\$ 24,000	\$ 240,000
Hammermill (G ₃)	Welded steel construction, direct connected 40 HP 3600 RPM motor, capacity 3000 lb/hr	1	\$ 22,000	\$ 22,000
Screw conveyor	Capacity 400 ft ³ /hr, diameter of flights 10", length 30', drive HP 1.69	5	\$ 2,750	\$ 13,750
Cell growth fermentor (B ₁)	Volume 4.08 × 10 ⁴ gallons, agitated, stainless steel construction	5	\$ 22,300	\$ 111,500
Agitator motor coupled with B ₁	Rating 2 HP	5	\$ 556	\$ 2,780
Air compressor coupled with B ₁	Unit rating 4 HP, centrifugal type	5	\$ 1,769	\$ 8,845
Induction fermentor (B ₂)	Volume 4.08 × 10 ⁵ gallons, agitated, stainless steel construction	5	\$ 89,000	\$ 445,000

TABLE 7. (continued)

Item	Description of each unit	No. of units	Cost/unit	Total purchased cost
Agitator motor coupled with B ₂	Unit rating 100 HP	5	\$ 3,500	\$ 17,500
Air compressor coupled with B ₂	Centrifugal type, unit rating 40 HP	5	\$ 4,451	\$ 22,255
Mycelium filter (F ₃)	Pressure filter, filtration area 743 ft ²	1	\$ 13,600	\$ 13,600
Raw material mixing tank coupled with B ₁ and B ₂	Volume 10,280 gallons, steel construction, 30 HP agitator motor	1	\$ 11,200	\$ 11,200
Heat exchanger (E ₂)	Shell and tube type, condensing steam in shell side, heat transfer area 970 ft ²	1	\$ 7,012	\$ 7,012
Heat exchanger (E ₃)	Shell and tube type, heat transfer area 780 ft ²	1	\$ 5,420	\$ 5,420
Heat exchanger (E ₁)	Shell and tube type, heat transfer area 848 ft ²	3	\$ 6,150	\$ 18,450
Distillation column (D)	9.04 ft diameter, 23 sieve trays with 24" tray spacing	1	\$ 43,000	\$ 43,000
Enzyme filter (F ₂)	Plate and frame pressure filter - filtration area 1010 ft ²	7	\$ 18,300	\$ 128,100
Reboiler furnace (R)	Direct fired furnace, heat duty 31.4 × 10 ⁶ <u>BTU</u> hr	5	\$ 124,083	\$ 620,416

TABLE 7. (continued)

Item	Description of each unit	No. of units	Cost/unit	Total purchased cost
Condenser (E ₅)	Carbon steel construction, heat transfer area 3550 ft ²	5	\$ 11,400	\$ 57,000
Heat exchanger (E ₄)	Shell and tube type, transfer area 793 ft ²	2	\$ 5,733	\$ 11,466
Hydrolyzer (H)	Concrete digester, agitated, placed below ground level, volume 5.54×10 ⁵ gallons	5	\$ 222,000	\$1,110,000
Agitator motor coupled with (H)	Rating 260 HP	5	\$ 11,100	\$ 55,500
Solids filter (F ₁)	Industrial vacuum drum filter, filtration area 1380 ft ²	1	\$ 54,300	\$ 54,300
Mixing tanks for absorption/wash train	Agitated carbon steel mixing vessels, volume 18.5×10 ⁴ gallons	11	\$ 64,000	\$ 704,000
Agitator motor coupled with above	Unit rating 100 HP	11	\$ 3,500	\$ 38,500
Filters for adsorption/wash train	Industrial vacuum drum filters, filtration area 1380 ft ²	11	\$ 54,300	\$ 597,300

TABLE 8

	Processing Unit	Power Input (HP)
5	hydrolysis vessels	1295.00
11	agitated mixers for enzyme recovery	951.50
5	enzyme induction vessels	810.00
5	induction vessel compressors	801.00
5	fermentor compressors	80.10
10	shredders of waste paper	750.00
10	hammermills for grinding waste paper	900.00
1	shredder/grinder for enzyme induction	40.00
5	screw conveyors	8.45
	Total	5636.05 HP

An efficiency of 21% for power plants is common and the equivalent thermal energy input for supply of electrical power is given by:

$$\frac{5636.05}{0.21} \times 2.5445 \times 10^3 \frac{\text{BTU}}{\text{hr}} = 68.29 \times 10^6 \frac{\text{BTU}}{\text{hr}}$$

The total thermal energy requirement of the process is $342.06 \frac{\text{BTU}}{\text{hr}}$.

This energy is to be generated by combustion of the spent cellulosics out of the hydrolyzer following filtration. The furnace complex will provide for direct heating for generation of electrical power and process steam.

The overall energy may be estimated as follows. The weight fractions of cellulose and lignin-hemicellulose in the spent solids are 0.216 and 0.784 and their respective heating values are $7525 \frac{\text{BTU}}{\text{lb}}$ and $13,275 \frac{\text{BTU}}{\text{lb}}$. Assuming heating values of cellulose and lignin-hemi-

cellulose to be additive and after allowance for the water content of the filtered solids $\left(\frac{1 \text{ lb H}_2\text{O}}{1 \text{ lb dry solids}} \right)$ the net heat of combustion is $10,979 \frac{\text{BTU}}{\text{lb}}$. The total quantity of spent solids available is 416.44 tons/day, corresponding to an available energy of $381.00 \times 10^6 \frac{\text{BTU}}{\text{hr}}$ to be generated by combustion. This latter quantity represents an excess of $51.4 \times 10^6 \frac{\text{BTU}}{\text{hr}}$ over the estimated total requirement.

It appears therefore that the waste solids are sufficient for the energy requirements of the entire process. No separate energy input is required. Part of the excess energy will obviously be used for pumping and other accessories the detailed calculation of which is beyond the scope of this study.

Electrical power generation facilities are not shown in the flow sheet, or designed for cost estimation. Rather, a standard cose of \$ 0.0075/KWH has been assigned for electrical power which will include the capital investment a mortization and operating costs. Process steam facilities have been treated similarly.

5.4. Economic Evaluation

5.4.1 Fixed Capital Investment

On the basis of the estimated costs of the principal items of equipment listed in Table 7 the total fixed capital investment is calculated following the procedure recommended by Peters (1). The cost factors used are described in Table 9.

TABLE 9. Cost factors for estimation of fixed capital investment

Category	% of purchased equipment cost	
Piping		20
Instrumentation		10
Insulation		5
Electrical Installation		10
Building/Services		20
Land/Yard		10
Total physical plant cost	≡	1.75 purchased equipment cost
Engineering and construction	≡	25% physical plant cost
Total direct plant cost	≡	2.1875 purchased equipment cost
Contractors fees	≡	5% of direct plant cost
Contingency	≡	10% of direct plant cost
Fixed capital investment	≡	2.4505 purchased equipment cost

For the concrete digestors the unit cost of \$ 3.00/ft³ already includes the engineering construction cost and contractors fees. A multiplier of 1.68 is used instead of 2.4505 for this case. For a plant utilizing 833 tons/day (dry basis) of waste paper the total fixed capital investment is estimated at \$10,134,334. An on-stream efficiency of 90% for the entire process is assumed. Depreciation is estimated on a straight line over a period of 10 years. The insurance and interest rates are assumed at 1% and 6% respectively. Labour costs are assigned a value of \$3.50/man-hour

5.4.2 Utilities and Raw materials

Utilities costs are assigned in Table 10.

TABLE 10. Utilities Costs

Utility	Unit Cost
Power (generated in-plant)	\$ 0.0075/KWH
Process steam at 120 psig (in-plant)	\$ 0.325/1000 lbs.
Cooling water	\$ 0.01/1000 gallons
Process water	\$ 0.49/1000 gallons

Raw material costs are listed in Table 11. No cost is assigned for the waste cellulosics. If a market price of \$ 23.00/ton for waste paper is assumed an additional 2.07 cents/lb glucose produced is added to the present estimated cost.

TABLE 11. Raw Materials Costs. *

Raw Material	Unit Cost
Superphosphate	\$ 0.02/lb
Proflo Oil (cotton/seed oil-meal)	\$ 0.10/lb
Acetone	\$ 0.069/lb

* Raw material costs for this process design are based on market prices as of January 1973. During the Phase Four economic controls the price of agricultural goods (soybean particularly) in some cases has increased by as much as 200% necessitating a general check on the existing prices as of late 1973. Chemical Marketing Reporter of August 20, 1973 revealed the price of Cottonseed Oilmeal to be \$200/ton (same as that of the present design) but the general outlook remains uncertain and some price increase in the near future is expected. The market price of Dextrose (hydrated) was reported at 10¢/lb; the present design cost estimate of a 5.5% sugar solution at 1¢/lb compares quite favourably with the same.

5.4.3. Total cost analysis

The resulting total costs and costs per unit of product for hydrolysis at 2.7 F. P. units enzyme activity are listed in Table 12 for each of the major processing sections: (1) hydrolysis, (2) pretreatment, (3) enzyme recovery, and (4) enzyme make-up. Similar cost summaries for hydrolysis at 2.0 F. P. and 1.3 F. P. are listed in Tables 13 and 14 respectively. A possible credit for mycelium as cattle feed supplement is included in these estimates.

The summary of the total cost analysis for these 3 cases is presented in Table 15. The most economic design (in terms of unit cost of product) is that employing hydrolyzing enzyme activity at 2.0 F. P.

TABLE 15. Summary of total cost analysis

Enzyme Activity for hydrolysis	Manufacturing cost without credit for mycelium (¢/lb. glucose)	Manufacturing cost with credit for mycelium (¢/lb. glucose)
2.70 F. P.	1.538	1.353
2.00 F. P.	1.273	1.150
1.30 F. P.	1.414	1.314

TABLE 12. Design Basis: Plant feed rate 833 tons/day (dry basis); On stream efficiency 90% ;
 Enzyme activity 2.7 F.P. ; Hydrolysis time 40 hrs. corresponding 82% conversion;
 Cellulose composition of waste paper 61%

OPERATION	HYDROLYSIS (\$ /day)	PRETREATMENT (\$ /day)	ENZYME RECOVERY (\$ /day)	ENZYME MAKE-UP (\$ /day)	TOTAL (\$ /day)
<u>Cost Item</u>					
Raw Material	0	0	0	1043.30	
Labor	168.00	84.00	168.00	168.00	
Supervision	25.20	12.60	25.20	25.20	
Maintenance	333.72	199.68	539.70	854.40	
Plant Supplies	50.06	29.95	80.96	128.16	
Utilities	1032.42	204.50	116.00	649.28	
Direct Manf. Cost	1609.40	530.73	929.86	2868.34	5938.33
Payroll Overhead	25.20	12.60	25.20	25.20	
Laboratory	25.20	12.60	25.20	25.20	
Plant Overhead	84.00	42.00	84.00	84.00	
Indirect Manf. Cost	134.40	67.20	134.40	134.40	470.40
Depreciation	556.23	332.83	899.50	1423.97	
Insurance	55.62	33.28	89.95	142.40	
Interest	333.72	199.68	539.70	854.40	5461.28
Fixed Manf. Cost	945.57	565.79	1529.15	2420.77	5461.28

TABLE 12. (continued)

<u>OPERATION</u>	<u>HYDROLYSIS</u> <u>(\$ /day)</u>	<u>PRETREATMENT</u> <u>(\$ /day)</u>	<u>ENZYME</u> <u>RECOVERY</u> <u>(\$ /day)</u>	<u>ENZYME</u> <u>MAKE-UP</u> <u>(\$ /day)</u>	<u>TOTAL</u> <u>(\$ /day)</u>
<u>Cost Item</u>					
Total Manf. Cost	2689.37	1163.72	2593.41	5423.51	11870.01
\$ /lb glucose	0.00348 (22.65%)	0.00151 (9.80%)	0.00336 (21.84%)	0.00703 (45.71%)	0.01538 (100%)
Possible credit for mycelium as cattle feed supplement			0.037 lb mycelium/lb glucose at 5 cents/lb.		0.00185
Net Manf. Cost (\$ /lb. glucose)					0.01353

TABLE 13. Design Basis: Plant feed rate 833 tons/day (dry basis); On Stream efficiency 90% ;
 Enzyme activity 2.0 F. P. ; Hydrolysis time 57 hrs. corresponding to 82% conversion;
 Cellulose content of waste paper 61%

<u>OPERATION</u>	<u>HYDROLYSIS</u> (\$ /day)	<u>PRETREATMENT</u> (\$ /day)	<u>ENZYME</u> <u>RECOVERY</u> (\$ /day)	<u>ENZYME</u> <u>MAKE-UP</u> (\$ /day)	<u>TOTAL</u> (\$ /day)
<u>Cost Item</u>					
Raw Material	0	0	0	691.71	
Labor	168.00	84.00	168.00	168.00	
Supervision	25.20	12.60	25.20	25.20	
Maintenance	317.04	199.68	539.70	570.90	
Plant Supplies	47.56	29.95	80.96	85.64	
Utilities	998.75	204.50	116.00	441.69	
Direct Manf. Cost	1556.55	530.73	929.86	1983.14	
Payroll Overhead	25.20	12.60	25.20	25.20	
Laboratory	25.20	12.60	25.20	25.20	
Plant Overhead	84.00	42.00	84.00	84.00	
Indirect Manf. Cost	134.40	67.20	134.40	134.40	
Depreciation	528.42	332.83	899.50	951.50	
Insurance	52.84	33.28	89.95	95.15	
Interest	317.04	199.68	539.70	570.90	
Fixed Manf. Cost	898.30	565.79	1529.15	1617.55	

TABLE 13. (continued)

<u>OPERATION</u>	<u>HYDROLYSIS</u> <u>(\$ /day)</u>	<u>PRETREATMENT</u> <u>(\$ /day)</u>	<u>ENZYME</u> <u>RECOVERY</u> <u>(\$ /day)</u>	<u>ENZYME</u> <u>MAKE-UP</u> <u>(\$ /day)</u>	<u>TOTAL</u> <u>(\$ /day)</u>
<u>Cost Item</u>					
Total Manf. Cost	2589.25	1163.72	2593.41	3735.09	10,081.47
\$ /lb glucose	0.00,327 (25.69%)	0.00147 (11.54%)	0.00,327 (25.72%)	0.00472 (37.05%)	0.01273 (100%)
Possible credit for mycelium as cattle feed supplement 5 cents/lb.			0.0245 lb. mycellium/lb glucose at		0.00123
Net Manf. Cost (\$ /lb. glucose)					0.01150

TABLE 14. Design Basis: Plant feed rate 833 tons/day (dry basis); On Stream efficiency 90%
 Enzyme activity 1.3 F.P.; Hydrolysis time 60 hrs. corresponding to 70% conversion
 Cellulose content of waste paper 61%

<u>OPERATION</u>	<u>HYDROLYSIS</u> <u>(\$ /day)</u>	<u>PRETREATMENT</u> <u>(\$ /day)</u>	<u>ENZYME</u> <u>RECOVERY</u> <u>(\$ /day)</u>	<u>ENZYME</u> <u>MAKE-UP</u> <u>(\$ /day)</u>	<u>TOTAL</u> <u>(\$ /day)</u>
<u>Cost Item</u>					
Raw Material	0	0	0	457.76	
Labor	168.00	84.00	168.00	168.00	
Supervision	25.20	12.60	25.20	25.20	
Maintenance	522.24	199.68	441.60	182.70	
Plant Supplies	78.34	29.95	66.24	27.41	
Utilities	1136.92	204.50	95.00	223.65	
Direct Manf. Cost	1930.70	530.73	796.04	1084.72	
Payroll Overhead	25.20	12.60	25.20	25.20	
Laboratory	25.20	12.60	25.20	25.20	
Plant Overhead	84.00	42.00	84.00	84.00	
Indirect Manf. Cost	134.40	67.20	134.40	134.40	
Depreciation	870.36	332.83	735.96	304.48	
Insurance	87.04	33.28	73.60	30.45	
Interest	522.24	199.68	441.60	182.70	
Fixed Manf. Cost	1479.64	565.79	1251.16	517.63	

TABLE 14. (continued)

<u>OPERATION</u>	<u>HYDROLYSIS</u> <u>(\$ /day)</u>	<u>PRETREATMENT</u> <u>(\$ /day)</u>	<u>ENZYME</u> <u>RECOVERY</u> <u>(\$ /day)</u>	<u>ENZYME</u> <u>MAKE-UP</u> <u>(\$ /day)</u>	<u>TOTAL</u> <u>(\$ /day)</u>
<u>Cost Item</u>					
Total Manf. Cost	3544.74	1163.72	2181.60	1736.75	8626.81
\$ /lb. glucose	0.00581 (41.08%)	0.00191 (13.49%)	0.00358 (25.29%)	0.00284 (20.14%)	0.01414 (100%)
Possible credit for mycelium as cattle feed equipment			0.02 lb. mycelium/lb. glucose at 5 cents/lb.		0.0010
Net Manf. Cost (\$ /lb. glucose)					0.01314

5.4.4 Discussion of Design Assumptions and Cost Analysis

The present process analysis has been based on the original specification of Ghose and Kostic (2) that milling of cellulose to -200 mesh provided adequate size reduction. This specification was found to be satisfactory in our studies on ball milled newsprint as described in Section 4.3. However, the equipment and power requirements for obtaining suitable milling in large scale operation have not been studied and should be recognized as an area of uncertainty in the cost estimate. Our design has assumed that the hydrolysis results would not be dependent upon the manner in which the size reduction was attained. (As discussed below this assumption may not be correct.)

A preliminary milling equipment specification utilizing Williams Co. hammermills and air classifiers was obtained from the Empire Equipment Corporation, Pasadena, California. An overall power requirement of 40 KWH/ton was estimated to reduce paper to 80% -200 mesh. This estimate seems generally in the range of power requirements for moderate grinding of various organic materials reported by Perry (3).

Recently, Mandels, Hontz, and Nystrom (4) have reported data on the hydrolysis of various cellulosic materials with T. viride cellulase for various types of milling which confirm that fine milling is required for maximum conversion. However, the results also suggest that lower but economically acceptable levels of conversion may be possible with material that has been milled much less strenuously. A few examples of these data obtained for 5% suspensions of solids which appear most pertinent to the present study are given in Table 15 below, along with some of our results on ball milled newsprint from the tabulation on p. 105

and the extrapolated values assumed in the process design calculations.

From these data it appears that susceptibility to hydrolysis is almost as good with the light milling or shredding used by Mandels, et al. as for the present work with ball milling. Considering the case of newspaper specifically, the Mighty Mac Mulcher material gave 42% conversion in 48 hours vs. 50-58% for our ball milled paper in 40 hours. If the non-lignin composition of the two papers can be assumed similar, and assuming similar behavior for 5% and 10% suspensions, one might expect a total conversion of at least 40% for our paper (after allowance for difference in lignin content) at 2.7 filter paper activity if the material were shredded with the Mighty Mac Mulcher. Therefore, instead of the 82% conversion of α -cellulose assumed in the original designs for 2.7 and 2.0 filter paper activity a conversion of 69% might be more likely. Milling of the type obtained with the Mighty Mac Mulcher or Jay Bee Disintegrator should not cost more than the shredding and hammer-milling assumed in our original design. Therefore, attainment of the lower conversion would increase the processing cost by about 20%.

Since October 1973 when our original estimates were prepared, process equipment costs have risen by about 12%, based on the Marshall-Stevens index for 2nd Quarter 1974, and it might be assumed that this factor should apply to the entire process.

Another uncertainty which has been called to our attention is the possibility that the estimate of filter costs in the enzyme recovery system is too low. Since these are a major cost item, it is hoped that a less expensive type of solid-liquid separation technique will be

TABLE 15
SOME COMPARISONS OF MILLING METHODS WITH RESPECT TO
HYDROLYSIS OF CELLULOSIC MATERIALS

Material	Type of Milling	Approximate Filter Paper Activity	Hydrolysis Time, hour	% Conversion of α Cellulose	% Conversion of total sample (as glucose)	Investigators
Corrugated Fiberboard (18.8% Lignin)	Mighty Mac ¹ Mulcher	3-4	48	N/A	55	Mandels, et al. ⁽⁴⁾
Newspaper (27.3% Lignin)	Mighty Mac Mulcher	3-4	48	N/A	42	Mandels, et al. ⁽⁴⁾
Computer Print-out (14.3% Lignin)	Jay Bee Disintegrator ²	3-4	48	N/A	51	Mandels, et al. ⁽⁴⁾
Key Punch Holes	None	3-4	48	N/A	56	Mandels, et al. ⁽⁴⁾
Newsprint (24.5% Lignin)	Ball mill -200 to +300 mesh (Tyler)	4.4	40	95	58	This Work
Newsprint (24.5% Lignin)	Ball mill -200 to +300 mesh (Tyler)	2.7	40	82	50	This Work
Newsprint (24.5% Lignin)	Ball mill -200 to +300 mesh (Tyler)	2.0	57	82	50	This Work (extrapolated)
Newsprint (24.5% Lignin)	Ball mill -200 to +300	1.3	60	70	43	This Work (extrapolated)

1. Amerind MacKissic Co., Parker Ford, Pa. A small garden Mulcher which reduces paper to pieces several centimeters in diameter.
2. M. B. Sedberry Inc., Tyler Texas. This shredder is basically a hammer mill with impact blades and screen running at a fixed RPM. Paper is fed to the shredder one sheet at a time producing a fibrous pulp of very low bulk density.

possible. If the 12 vacuum filters specified for the process were quadrupled in cost* the fixed capital investment would be increased by \$4,800,000 and the processing cost would be increased by 75%, or about 1¢ per pound.

Another uncertainty would be the effect of the type of milling on the adsorption characteristics of the enzyme which could also affect the recovery system. A limiting case for evaluation of this aspect of the process would be an operation with no enzyme recovery system at all. In this case the additional enzyme production required would result in an additional processing cost of 5.2¢ per lb of sugar at 2.0 filter paper activity (after allowance for elimination of the enzyme recovery system).

For the optimum case given in Table 13, effects of the foregoing assumptions in various combinations on the processing cost may be summarized as follows:

	Processing Cost per lb sugar produced in aqueous solution)
Original design 82% conversion	1.3 ¢
69% conversion plus 12% inflation factor	1.7 ¢
69% conversion plus 12% inflation factor plus quadrupled filter costs	2.8 ¢
69% conversion plus 12% inflation factor with no enzyme recovery system	8.0 ¢

* Indicated by an approximate cost estimate from Dorr-Oliver, August 1974.

Further research is needed to provide more accurate costs.

However, with a current price for solid glucose of 23 ¢ per lb (10/74) the proposed process appears promising at even the highest of the above estimates.

5.5. Suggestions for Future Study

Further definitive studies are required for improving the process economics. Decrease of hydrolytic reaction time for a given amount of conversion is a step in this direction. Breaking down of lignosulfonates in waste paper with fungal 'Lignase' should be promising since this removes the physical barrier between the cellulose molecule and cellulase enzyme. The optimum way to use lignase in the hydrolytic step will obviously be dependent upon experimental observations with these two enzyme systems.

Quantitative studies are needed for identification of hydrolytic products. The proportion of mono, di and tri saccharides produced during hydrolysis and their effect on subsequent fermentability by yeast should be a very interesting area of study. Furthermore, efforts to depress the formation of cellobiose by the use of fungal β -glucosidase should be pursued since cellobiose is known to inhibit the breakdown of β , 1-4 linkages. Last, but not the least, alternative sources of cellulase should be looked into. Thermophilic fungi isolated from self-heated wood-chips and mesophilic fungi of the genus Fusarium are important in this context.

Literature Cited

1. Peters, M. S., Tinnerhaus, K. D., Plant Design and Economics for Chemical Engineers, McGraw Hill, Second Edition (1968).
2. Ghose, T. K. and Kostick, J. A., Adv. in Chem. Science 95, 415 (1969).
3. Perry, R. H. and Chilton, C. H., Section 8: "Size Reduction and Size Enlargement," Chemical Engineers' Handbook (Fifth Ed.), McGraw-Hill, Inc., 1973.
4. Mandels, M., U. S. Army Natick Laboratories, personal communication, August 16, 1974--to be published in Bioengineering Biotechnology.

APPENDIX A

Hydrolysis

Substrate utilized is 885 tons/day of waste paper (6% moisture) containing 61% cellulose. Hence on dry basis the feed rate to the hydrolyzers is 508 tons/day of cellulose and 325 tons/day of non-cellulosic material (mainly lignin and hemicellulose). Since a 10% solid suspension (dry basis) is maintained in the hydrolyzers, the incoming liquid flow rate is 8330 tons/day or 1.994×10^6 gallons/day (GPD).

For a residence time of 40 hours at 2.7 Filter Paper (F.P.) enzyme activity the conversion of cellulose is 82% (Figure 27, Chapter 4). Hence the amount of reducing sugar produced is 462.38 tons/day and the spent solids in the effluent amount to 416.44 tons/day.

The effluent liquid is a 5.6% reducing sugar solution. According to the experiments conducted by the author an increase of 3.4% of liquid volume takes place at 50°C due to this sugar dissolution. Accounting for the water content of the spent solids at 1 lb. H₂O/lb dry solids a resultant net increase of 1.58% of liquid volume takes place. Hence the net liquid flow out of the hydrolyzers following filtration is 2.026×10^6 GPD.

The total residence time during countercurrent

adsorption is 10 hours at 50°C. The net residence time in the hydrolyzers is consequently 30 hours. The total liquid volume in the hydrolyzers is 24.93×10^5 gallons and the total vessel volume is 27.70×10^5 gallons (liquid volume = 90% of hydrolyzer tank volume). Concrete digestors used in solid waste treatment are deemed appropriate for use as hydrolyzers in this case. These are agitated by turbine agitators, cylindrical in shape and buried below ground level. Five individual units are used, each with a volume of 5.54×10^5 gallons.

Power required to suspend the ground newsprint in the hydrolyzer liquid according to Calderbank and Moo-Young (1)

$$\frac{P}{V} = 32.09 \times \frac{(g\Delta\rho)^{4/3} \mu_c^{1/3}}{\rho_c^{2/3}}$$

where,

P/V = power dissipated by agitator per unit
volume of continuous phase

$\Delta\rho$ = density difference between dispersed and
continuous phase

μ_c = continuous phase viscosity

ρ_c = continuous phase density

g = acceleration due to gravity

$\Delta\rho$ for this case = 0.05 gm/ml

μ_c (water at 50°C = 0.56 centipoise

ρ_c = 1.00 gm/ml

Substituting these values in the above equation

$$\frac{P}{V} = 0.52 \text{ Horsepower/1000 gallons}$$

Cost of concrete digestors are estimated at \$3/cubic feet as of late 1973 according to personal communications with Professor Oswald of Sanitary Engineering Department of the University of California at Berkeley. This figure includes engineering-construction cost and contractor's fees. At this rate unit digester cost equals \$222,000 and for five units total cost equal \$1,110,000. Cost of the 260 HP agitator motor is estimated from standard chemical engineering sources (2,3) and updated to the last quarter of 1973 according to Marshall-Stevens cost indices. Unit motor cost is \$11,000, five units are required for a total of \$55,500.

During hydrolysis the incoming liquid stream has to be heated from 25°C to reaction temperature of 50°C.

$$\Delta T = 122 - 77 = 45^\circ F$$

$$\begin{aligned} \text{Heat to be supplied} &= \frac{8.31 \times 10^4}{7.48} \times 62.5 \times 1 \times 45 \frac{\text{BTU}}{\text{hr}} \\ &= 31.25 \times 10^6 \frac{\text{BTU}}{\text{hr}} \end{aligned}$$

This heat is to be supplied by heat exchange with incoming liquid to the fermentor following sterilization:

Liquid stream to fermentor equals $30.7 \times 10^4 \frac{\text{lb}}{\text{hr}}$

(numerical value derived later in this chapter) to be cooled down from 191°F to 86°F. Potential heat available equals $32.20 \times 10^6 \frac{\text{BTU}}{\text{hr}}$ and log-mean temperature difference is 31.6°F. Assuming an overall heat transfer coefficient of $400 \frac{\text{BTU}}{\text{hr ft}^2 \text{°F}}$ (Chemical Engineering Handbook, Perry, 4th Edition) the heat transfer area requirement is 2545 ft². The cost of the exchanger is included within the enzyme make-up section.

Filtration of Unhydrolyzed Solids

Industrial vacuum drum filter (Dorr-Oliver Co.) is used for separating unhydrolyzed solids from the reducing sugar solution following hydrolysis. Vacuum drum filter is chosen for its effective use in continuous operation with minimum amount of labor and maintenance costs. Laboratory filtration results (Figure 35) are scaled up to the operating pressure of 0.9 atm according to the method suggested in Chemical Engineers Handbook by Perry (Section 19-56; 4th Edition). For constant pressure operation:

$$\frac{(\text{Filtration rate})_{\text{at pr. } P_1}}{(\text{Filtration rate})_{\text{at pr. } P_2}} = \left(\frac{P_2}{P_1} \right)^S$$

where P_1 is the original pressure at which the experiments are conducted and P_2 is the scaled up pressure. S is the compressibility coefficient, for this design the cellulosic solids are assumed to be

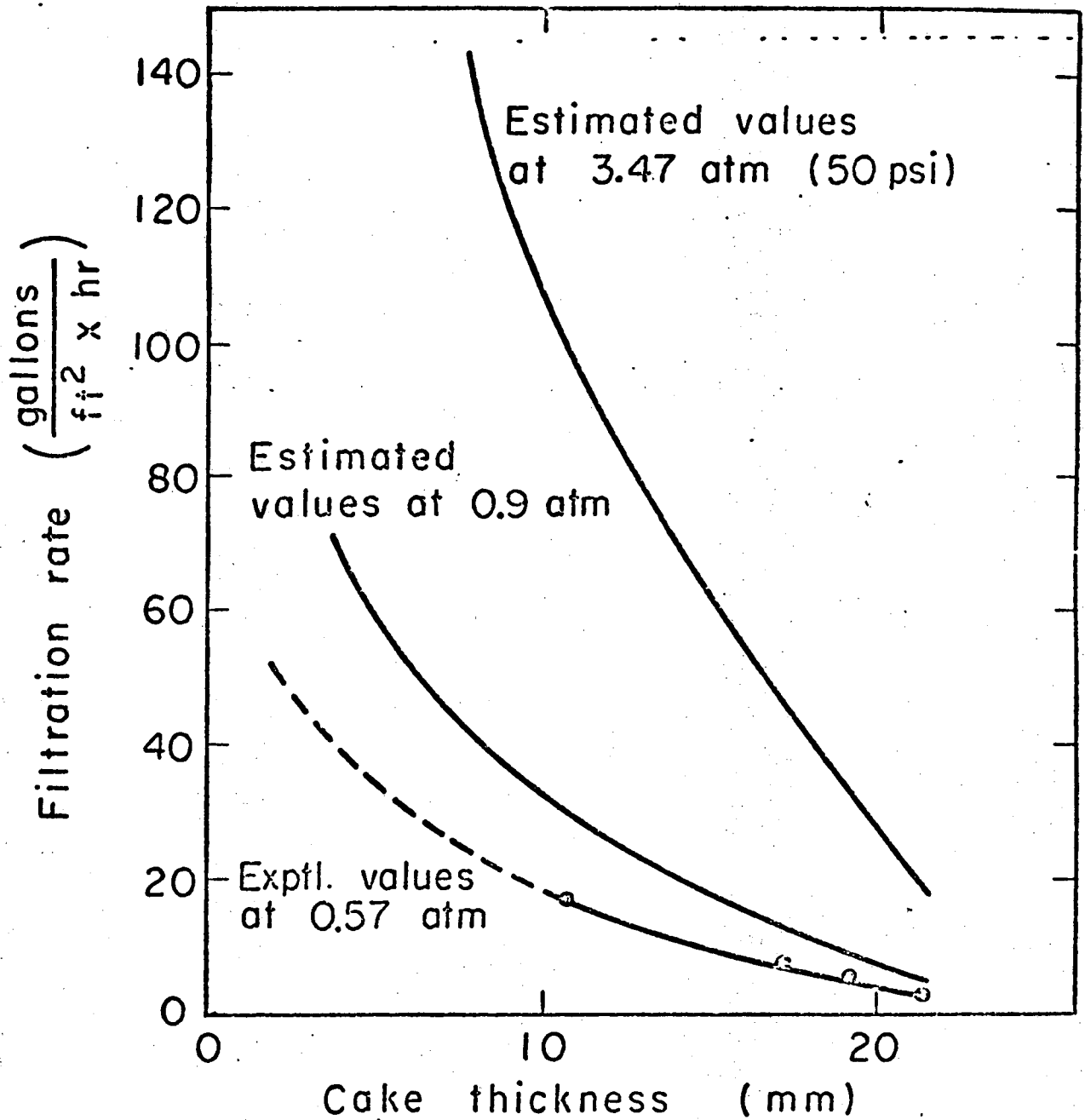

XBL7312-6994

Fig. 35. Scale-Up of Filtration Results

incompressible and hence S is unity. This analysis neglects the filter medium resistance which is small compared to the filter cake. The estimated filtration rates at 0.9 atm are shown in Figure 35. According to the manufacturer's (Dorr-Oliver) specifications a maximum allowable cake thickness for filtration of cellulosic solids is 10 mm, corresponding to an average cake thickness of 5 mm. From Figure 35 the average filtration rate is $60 \frac{\text{gallons}}{\text{ft}^2 \times \text{hr}}$. Since the volumetric flow rate is 2.026×10^6 GPD, the total filtration area requirement equals 1380 ft^2 . The manufacturer's (Dorr-Oliver Co.) suggested price for the vacuum drum filter is \$54,300. Major utilities in the hydrolysis section for 90% plant efficiency are as follows: Process water (at pH 4.8) at the rate of $1.994 \times 0.9 \times 10^6$ GPD (unit cost \$0.49/1000 gallons (2)) cost \$875.92/day. Self-generated power (unit cost \$0.0075/KWH (4)) cost for 868.5 kilowatts equals \$156.5/day. This power is utilized for agitation in the hydrolysis vessels. Hence the total cost for utilities in the hydrolysis section is \$1032.42/day.

Enzyme Recovery

According to the experimental results shown in Chapter 4, hydrolysis at 2.72 F.P. activity and pH 4.8 for 40 hours corresponds to 82% cellulose conversion (Fig. 27). The filtration of the effluents results in 51% of the C_1 activity in free solution and 49% of it

adsorbed on the spent solids (Fig. 32).

The liquid stream is contacted countercurrently with incoming freshly ground newspaper (833T/day) for recovery of this enzyme back into the hydrolysis vessels. Adsorption equilibrium data at 50°C with enzyme of 2.72 F.P. activity was shown in Figure 31 and according to the experimental results 60% of C_1 activity and 84% of C_x activity are adsorbed in contact with a 10% solid suspension. Since C_1 activity is adsorbed less the equilibrium relationship is based upon the distribution of C_1 activity in the two phases. The assumption here is that since C_x activity is adsorbed more a given recovery of C_1 activity through adsorption on the solid is sufficient for the recovery of C_x activity as well. Schematically the countercurrent adsorption arrangement is shown below.

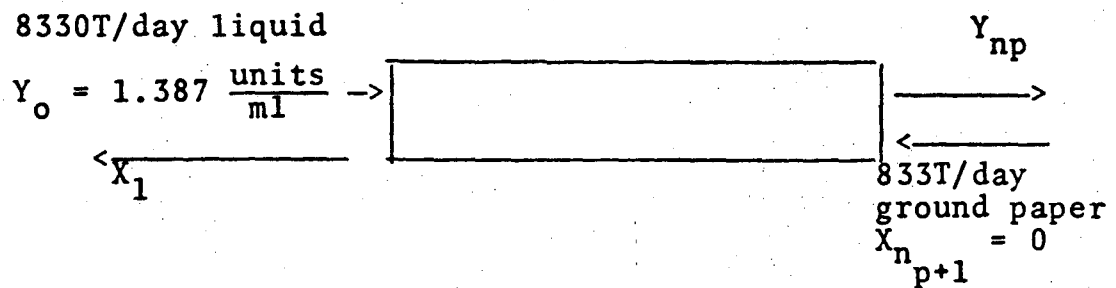

Schematically the arrangement is shown above where

$$Y_0 = \frac{\text{enzyme activity}}{\text{ml}} \text{ of incoming liquid}$$

$$Y_{n_p} = \frac{\text{enzyme activity}}{\text{ml}} \text{ of liquid after adsorption}$$

$$X_{n_{p+1}} = \frac{\text{enzyme activity}}{\text{gm solids}} \text{ of freshly ground paper}$$

$$X_1 = \frac{\text{enzyme activity}}{\text{gm solids}} \text{ after adsorption}$$

The equilibrium line based on the distribution of C_1 activity in contact with a 10% solid suspension is $Y = 0.067 X$. The operation line slope is 0.1 and 94.5% of the enzyme, activity is recovered. Hence the following values of X_1 and X_{n_p} are calculated:

$$X_1 = \frac{8330 \times 1.387 \times 0.945}{833} = 13.107 \frac{\text{enzyme units}}{\text{gm solids}}$$

$$Y_{n_p} = 1.387 \times 0.055 = 0.076 \frac{\text{enzyme units}}{\text{ml}}$$

Figure 36 shows the graphical construction for counter-current adsorption calculations of dilute solutions as given in Treybal (5). Five equilibrium stages are sufficient for this recovery. Overall activity loss is 2.8% of the original activity. Average residence time in each equilibrium stage is 2 hours (Fig. 30) and hence the liquid volume in each stage is 16.62×10^4 gallons. Assuming 90% of the mixing tank to be occupied by liquid the vessel volume for each stage corresponds to 18.47×10^4 gallons. Power requirement is calculated similar to the hydrolysis section and at 0.52 HP/1000 gallons this is estimated at 86.5 HP/stage.

Individual equilibrium stage of the adsorption train consists of a mixing vessel for equilibrium contact followed by a vacuum drum filter for the

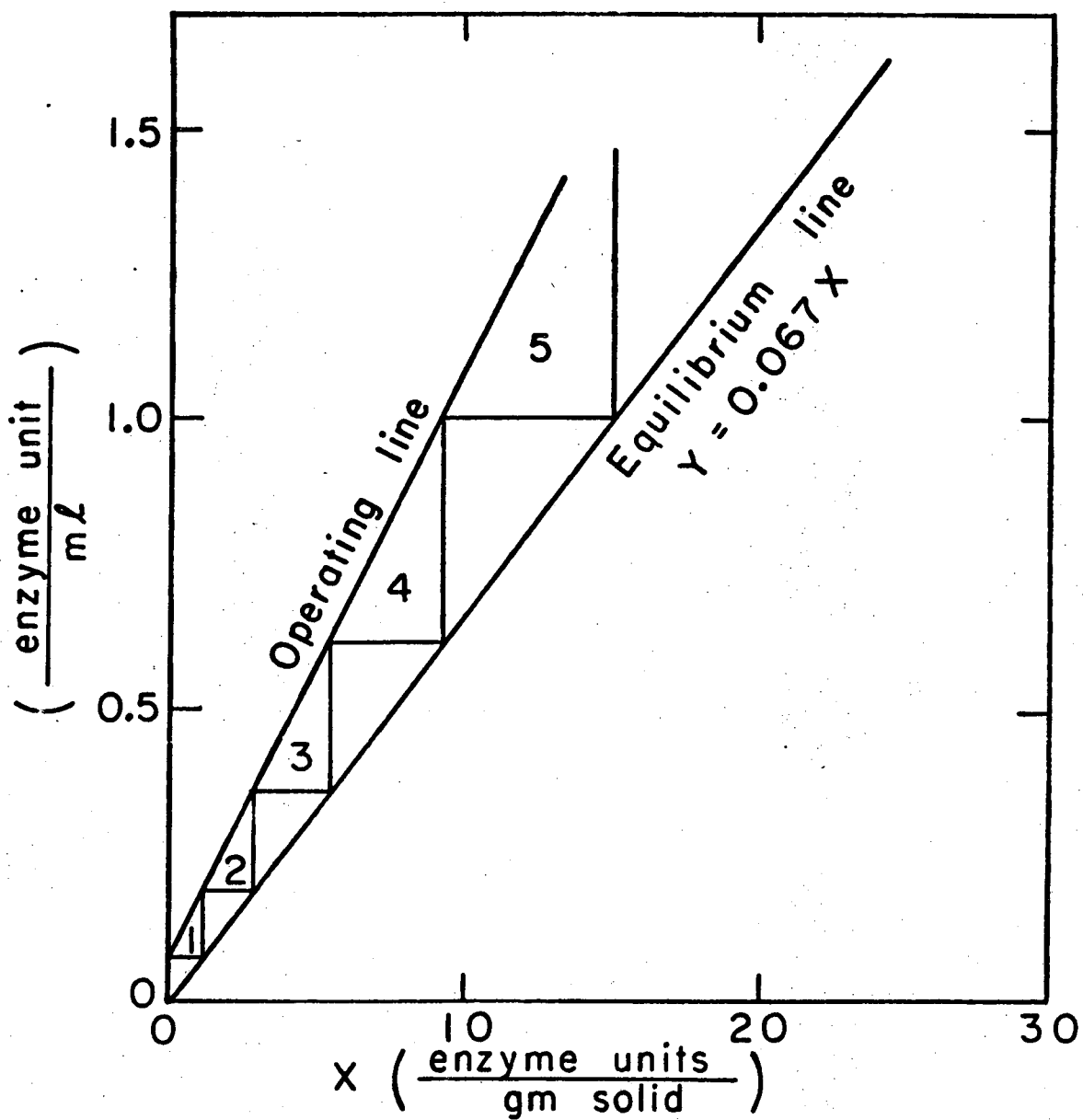

XBL7310-4357

Fig. 36. Countercurrent adsorption on freshly ground paper.

separation of the solid and the liquid phase. Vacuum drum filter is particularly appropriate here for easy of continuous operation and low maintenance and labour costs. For an operating pressure differential of 0.9 atm an average cake thickness of 5 mm is selected as in the hydrolysis section. Average filtration rate under this condition is estimated at 60 $\frac{\text{gallons}}{\text{ft}^2 \text{ x hr.}}$ (Fig. 35). Filtration area for each stage is 1380 ft². Five such vacuum drum filters are required.

The filtered solids following hydrolysis (cellulose conversion 82%) are washed countercurrently with the process water feed to the hydrolyzers (pH 4.8) to recover most of the adsorbed enzyme. Only C₁ activity remains adsorbed (Fig. 32), all of the C_x activity remains in the liquid. The schematic arrangement is as presented below:

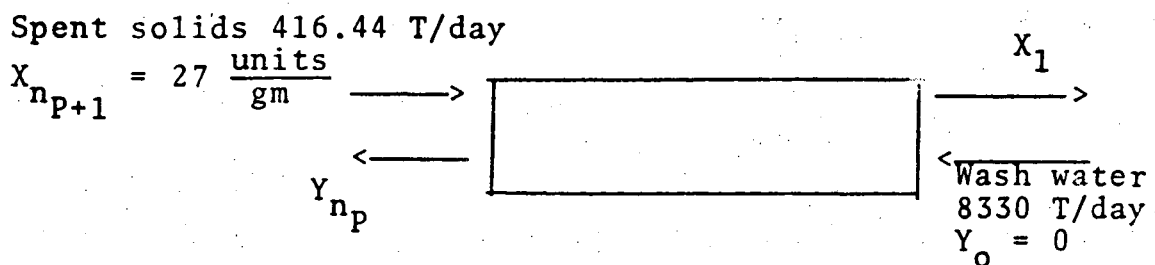

where

- $Y_0 = \frac{\text{enzyme units}}{\text{ml}}$ of incoming wash water
- $Y_{n_p} = \frac{\text{enzyme units}}{\text{ml}}$ of wash liquid following desorption
- $Y_{n_{p+1}} = \frac{\text{enzyme units}}{\text{gm solids}}$ of incoming spent solids
- $X_1 = \frac{\text{enzyme units}}{\text{gm solids}}$ following desorption

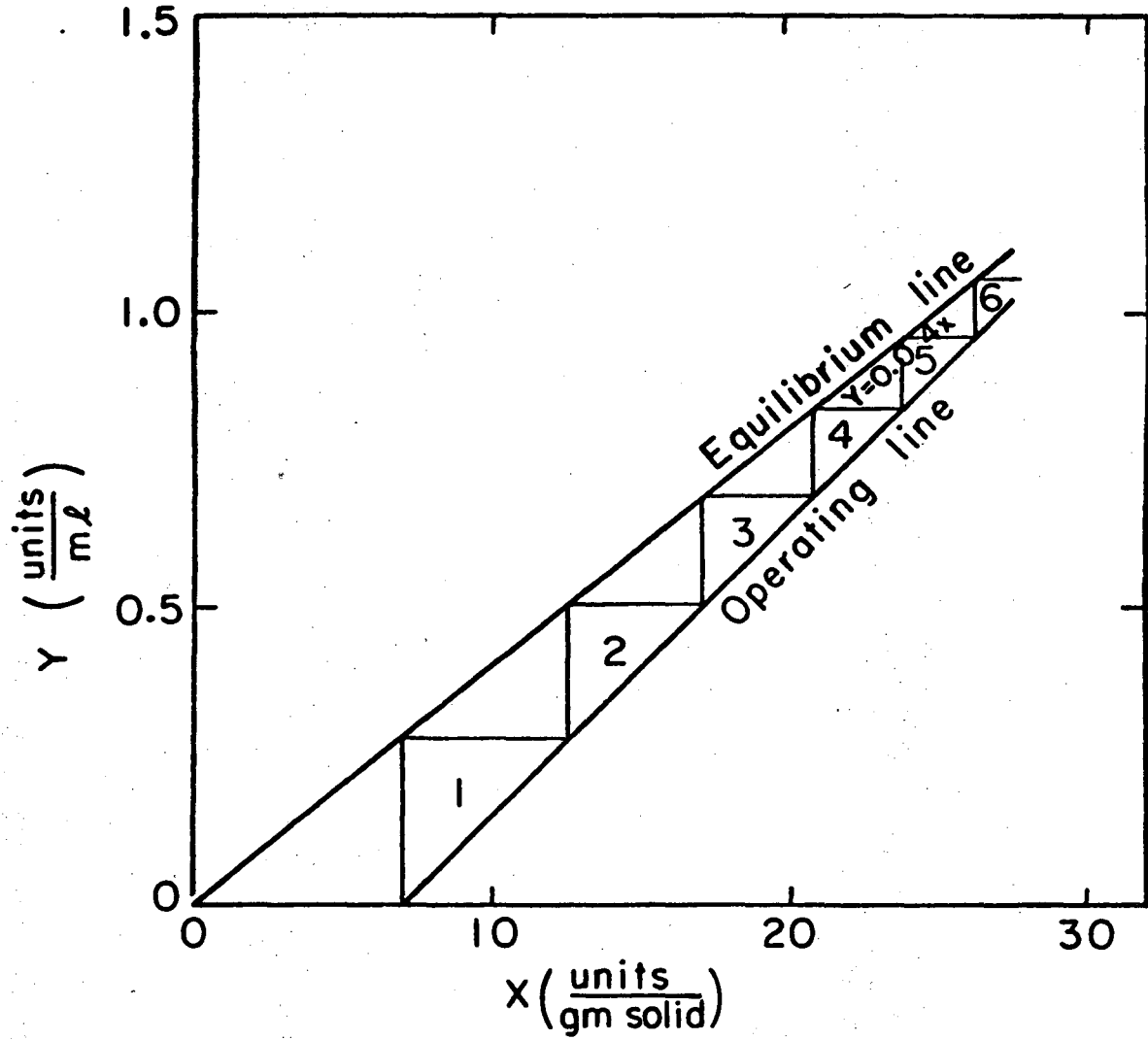

XBL7310-4354

The equilibrium relationship is based on the distribution of C_1 activity in the two phases and equals $Y = 0.04X$. The enzyme concentration in the outlet wash water stream is set at $1.01 \frac{\text{enzyme units}}{\text{ml}}$ and according to the graphical construction shown in Fig. 37, six equilibrium stages are sufficient to recover 74.3% of the adsorbed enzyme. The loss of 25.7% of the adsorbed enzyme corresponds to 12.6% of the original activity in the hydrolyzers. Analogous to the previous calculations the equipment specifications for the wash section are: 6 units of mixing vessels, each of volume 18.47×10^4 gals and with a power input of 86.5 HP; 6 units of vacuum drum filter, each with filtration area of 1380 ft^2 .

Total recovery from adsorption and wash sections equal 84.6% of the original enzyme activity in the hydrolyzers. Hence make up enzyme stream is to replenish the 15.40% loss at 2.7 F.P. enzyme activity.

Industrial vacuum drum filter costs were obtained from Dorr-Oliver Incorporated sales office at Oakland, California. For filters of 1380 ft^2 filtration area the unit cost as of 1973 is \$54,300; eleven units are required for a total cost of \$597,300.

Mixing tank costs were obtained from Cleveland Mixers Sales Office at South San Francisco. Cost of an 18.5×10^4 gallon volume agitated mixer is \$64,000; eleven units are required for a total cost of \$704,000

Agitator motor of 100 HP rating per mixer costs

\$3,500; the total cost for eleven units equal \$38,500.

The major utilities cost in the recovery section is the power input to the mixing vessels estimated at 646 kilowatts or \$116 per day.

Enzyme Production

Enzyme is produced at 1.3 F.P. activity in the amount of 8.85×10^5 GPD. This is equivalent to 3.07×10^5 GPD at 2.7 F.P. activity (Fig. 33).

Dilution rate in the enzyme induction vessel is 0.02 hr^{-1} (Chapter 4) giving rise to a liquid volume of 18.35×10^5 gallons. Assuming 90% of the tank volume to be liquid the total enzyme induction vessel size is 20.39×10^5 gallons. Ungassed power requirement is calculated as following: Let diameter be D and let 5 induction vessels of equal size are used

Assuming standard geometry

$$\frac{\pi}{4} D^3 = 13.9 \times 10^8 \text{ ml}$$

$$\therefore D = 1210 \text{ cm.}$$

Diameter of the impeller $D_i = 1/3 D = 403.3 \text{ cm.}$

Power number for turbulent range $N_p = 6$

but

$$N_p = \frac{P g_c}{\rho n^3 D_i^5}$$

where,

P = ungassed power

n = speed of impeller rotation = 23.22 r.p.m.
(sufficient to provide adequate mass transfer)

D. = impeller diameter = 403.3 cm.

g_c = conversion factor

ρ = density of the medium = 1 gm/ml.

Ungassed power P is calculated from the above equation to be 500 HP/induction vessel.

Aeration rate in these vessels is 1.12×10^5 liters/min. Gassed power requirement is calculated according to the correlation given by Michael et al.(7).

$$P_g = 0.00184 \left\{ \frac{P_n^2 D_i^3}{Q^{0.56}} \right\}^{0.45}$$

where,

P_g = gassed power requirement (HP)

P = ungassed power requirement = 500 HP

Q = aeration rate (liters/min) = 1.12×10^5 l/min.

n = impeller speed (r.p.m.) = 23.22 r.p.m.

D_i = diameter of the impeller (cm) = 403.3 cm.

Substituting these values in the above equation gassed power requirement P_g is calculated to be 357.7 HP.

For air compressor power requirement work done by the isothermal expansion of air in the liquid is given by

$$W = P_2 V_2 \ln \frac{P_1}{P_2}$$

where

P_1 = inlet air pressure = 30.35 psi

P_2 = outlet air pressure = 14 psi

V_2 = volume of air per pound at the outlet condition

Since molecular weight of air $M = 38.82$, with T denoting absolute temperature and R the universal gas constant, we obtain

$$V_2 = \frac{RT}{MP} = \frac{1}{28.82} \times \frac{1.544 \times 490 \times 10^3}{14 \times 144} = 13 \text{ ft}^3$$

Hence work done.

$$\begin{aligned} W &= (14 \times 144) \times 13 \times 0.74 \frac{\text{ft. lb. f}}{\text{lb air}} \\ &= 9.78 \times 10^{-3} \frac{\text{HP hr}}{\text{lb air}} \end{aligned}$$

Air flow rate is 1.82×10^4 lb/hr. and hence work done by the compressor is 178.0 HP. Assuming 89 percent compressor efficiency the rating is 200 HP, the impeller motor supplies the difference of 180 HP to the fermentor liquid.

For fungal growth the optimum dilution rate is 0.2 hr^{-1} (Chapter 4) and the above calculations are repeated to obtain the following results: 5 growth vessels each of volume 4.08×10^4 gallons is required. Agitation is provided by aeration only as it is sufficient for providing adequate mixing. 5 air compressors are required, each with a 20 HP rating for aeration of the growth fermentors. The work done by an individual compressor is 17.80 HP (89% efficiency). Raw material requirements for the liquid volume of 33.5×10^5 liter/day are as following:

$$\begin{aligned} \text{Superphosphate (0.3\%)} &= 9.75 \text{ tons/day} \\ \text{Proflo oil (0.05\%)} &= 1.625 \text{ tons/day} \end{aligned}$$

Sterilized plant feed (1% based on its
cellulose content) = 53.3 tons/day

Purchased equipment costs are obtained from reference (2) corresponding to a Marshall-Stevens Cost Index of 150.6. The current index for chemical processing equipments as published in Chemical Engineering of October 8, 1973 is 344.6. The purchased equipment costs are updated accordingly. Growth fermentor cost for 4.08×10^4 gallon volume is estimated at \$22,300. This is done on the basis of the purchased cost of an agitated Stainless Steel reaction vessel. Five units are required for a total cost of \$111,500. Air compressor (unit rating 20 HP) cost is \$8000. For five units the total cost is \$40,000.

Induction fermentor cost is similarly estimated on the basis of the purchased cost of an agitated Stainless Steel reaction vessel of volume 4.08×10^5 gallons. Unit cost is \$89,000. Five units are utilized for a total cost of \$445,000. Agitator motor (rating 200 HP) cost is \$9000 per unit. Five units are required for a total cost of \$45,000. Air compressor (200 HP rating) cost per unit is \$45,760. For five units the total cost is \$228,800.

The raw material costs are listed in Table (16). Following enzyme production the mycelium is separated in a pressure filter operating at a pressure differential of 50 psi. For an allowable cake thickness of 10 mm an average filtration rate of $108 \frac{\text{gallons}}{\text{ft}^2 \text{ x hr.}}$ is appropriate (Fig. 35). At this rate the time of filtration is 19 minutes after which the cake thickness reaches the allowable 10 mm limit. Cleaning the pressure filter and dumping the mycelium cake is assigned a time of 0.74 hr for every hour of filtration operation. This is a conservative estimate for operation of the plate and frame type pressure filters (9). The filtration area requirement is 743 ft^2 . Purchased cost obtained from Dorr-Oliver Company for this filter is \$13,600.

Raw material mixing tank volume is 10,280 gallons assuming a mixing time of 1/4 hour and 90% of vessel volume to be liquid. Power input during mixing is 27 HP calculated as shown in the hydrolysis section. Cost for the mixing vessel including agitator motor is obtained from Cleveland Mixers and equals \$11,200.

Feed Sterilization

The feed stream to the fermentors (8.85×10^5 GPD) is sterilized in the heat exchangers E_1 , E_2 , and E_3 . Exchanger E_3 heats the raw feed from 60°F to 160°F , utilizing exiting liquid stream from exchanger E_2 at

291°F as the heat source. Since the flow rates of these two streams are equal, the temperature changes of the two streams are the same. For liquid-liquid heat transfer for low viscosity liquids an overall heat transfer coefficient of $400 \frac{\text{BTU}}{\text{hr. ft}^2 \text{ } ^\circ\text{F}}$ is appropriate (9).

Log-mean temperature difference is 98.4°F and hence the effective heat transfer area is 780 ft². The feed next flows to the exchanger E₂ where it is heated from 160°F to 291°F by condensing steam at 120 psig (latent heat 878 $\frac{\text{BTU}}{\text{lb}}$). Log-mean temperature difference is 104°F giving rise to an effective heat exchanger area of 970 ft². Effective length of the holding section at 291°F for a 0.155 meter diameter piping is calculated according to the method suggested by Aiba et al. (10). Based on isothermal death rate data of Bacillus stearothermophilus FS 7954 the reaction rate constant at 291°F is 778 min⁻¹. A contamination level at 10⁵/ml and a sterility level of 10⁻³ result in a holding section length of about 1 ft. in the turbulent flow regime.

Heat exchanger E₁ cools the sterile medium from 191°F to 87°F by heating the wash water from 77°F to 112°F. Log-mean temperature difference is 31.6°F resulting in an effective heat transfer area of 2545 ft².

Heat exchanger costs (Shell and tube type) are identified from reference (2) and updated according to the current Marshall-Stevens Cost Index. Exchanger E₂

has a heat transfer area of 970 ft^2 for a purchased cost of \$7012. Exchanger E_3 has a heat transfer area of 780 ft^2 for a purchased cost of \$5420. Three exchangers, each with heat transfer area of 848 ft^2 , denote exchanger E_1 . Unit cost is \$6150 and hence the total cost is \$18,450.

Solvent Precipitation

The enzyme solution is added to 26.55×10^5 GPD of acetone for precipitation of the protein. The precipitated protein (4133 lb/day) is separated in a plate and frame filter press and transported to the hydrolysis reactors as the make up stream. 99.99% of the acetone is recovered from the liquid stream by distillation in a sieve plate column at 1 atmosphere pressure.

Filtration rate data of the precipitated protein at 50 psi is obtained from Ige (8). In absence of any filter aids the average rate is $42 \frac{\text{gallons}}{\text{ft}^2 \times \text{hr}}$ for an average cake thickness of 5 mm. This assumes incompressible filter cakes. Experiments in this area is still in progress and more reliable data should be forthcoming in the immediate future. This design utilizes the initial experimental results obtained without any addition of filter aids and assumes a washing and cleaning cycle of forty-five minutes and fifteen minutes respectively for every hour of filtration operation. These estimates of washing and cleaning cycles are on the conservative side (9) for

for plate and frame type filter operation. The effective filtration area requirement is 7060 ft^2 . Water content of the filter cake is assumed at one lb for every lb of solid filtered. The total solids filtered are 2.067 tons/day, corresponding to an acetone loss of 1.46 tons/day with the filter cake. Filter costs are obtained from Dorr-Oliver Company and for a filtration area of 1010 ft^2 the estimated purchase cost is \$18,300. Seven units are required for a total cost of \$128,100.

Solvent Recovery

Liquid volumetric flow rate is 5.58×10^5 liters/hr. Average molecular weight is 34.80 and the mole fraction of acetone is 0.42. This 134.19×10^5 moles/hr of feed is fed into a distillation column, 99.99% of the acetone is recovered from the top and recycled back to the precipitation stage together with make up acetone. Mole fraction of acetone at the top of the column is 0.9 and the following values are calculated:

$$\text{Top product flow rate } D = 62.98 \times 10^5 \text{ moles/hr}$$

$$\text{Bottom product flow rate } B = 71.20 \times 10^5 \text{ moles/hr}$$

Hence for 1 mole of feed, $D = 0.457$ mole and $B = 0.543$ mole. Incoming feed is preheated by heat exchanging with the bottoms from the distillation column ($2.825 \times 10^5 \frac{\text{lbm}}{\text{hr}}$) in cooling it down from 212°F to 106°F . The amount of heat available from this stream is $29.95 \times 10^6 \frac{\text{BTU}}{\text{hr}}$. Hence the temperature of $11.22 \times 10^5 \frac{\text{lb}}{\text{hr}}$ of

feed stream (specific heat = $0.79 \frac{\text{BTU}}{\text{hr}}$, density = $912 \frac{\text{gm}}{\text{liter}}$) is raised from 86°F to 120°F in the exchanger. Log-mean temperature difference is calculated to be 47.3°F and assuming an overall heat transfer coefficient of $400 \frac{\text{BTU}}{\text{hr ft}^2 \text{ } ^\circ\text{F}}$ (9) the total heat transfer area is computed to be 1586 ft^2 . The inlet temperature of the feed to the distillation column is fixed at 144.5°F (62.5°C) and hence an extra $21.70 \times 10^6 \frac{\text{BTU}}{\text{hr}}$ of heat is to be supplied by the reboiler furnace.

The acetone-water system is highly non-ideal and hence the calculation of number of stages in the distillation column is made by an enthalpy-concentration diagram utilizing the Ponchon-Savarit method (Fig. 38). A total condenser is used and the equilibrium data is obtained from Treybal (5). Reflux ratio used is 0.3. 15 ideal stages plus a reboiler is required for this separation with the feed being introduced at the 13th plate from the top. Average overall plate efficiency is 56% for sieve plate columns (6) and hence the actual number of plates is 23.

Let

Q_C be heat removed in the condenser

Q_R be heat added in the reboiler

According to the values shown in Figure 37

$$Q_C = 17,410 \times 62.983 \times 10^5 \times \frac{1}{453.6} = 241.50 \times 10^6 \frac{\text{BTU}}{\text{hr}}$$

$$Q_R = 10,000 \times 71.207 \times \frac{1}{453.6} = 157 \times 10^6 \frac{\text{BTU}}{\text{hr}}$$

$$\begin{aligned}\text{Total reboiler furnace load} &= (157 + 21.70) \times 10^6 \\ &= 178.70 \times 10^6 \frac{\text{BTU}}{\text{hr}}\end{aligned}$$

The heat load is supplied by a direct fired reboiler furnace, utilizing spent solids from hydrolyzer as fuel.

Assuming a furnace efficiency of 80%

$$\text{Furnace heat load} = 223.40 \times 10^6 \frac{\text{BTU}}{\text{hr}}$$

$$\text{Total condenser duty} = 241.50 \times 10^6 \frac{\text{BTU}}{\text{hr}}$$

Cooling water is available at 70°F and an outlet temperature of 120°F is assumed. Temperature at column top = 134°F. Hence log-mean temperature difference = 34°F. Assuming an overall heat transfer coefficient of $400 \frac{\text{BTU}}{\text{hr ft}^2 \text{ } ^\circ\text{F}}$ (9), the condenser heat transfer area is 17,750 ft² and cooling water requirement is 57.10⁴ gallons/hr.

Cost for the reboiler furnace and condenser is estimated from reference (2). The purchased cost for a Shell and tube type condenser of 3550 ft² area is \$11,400. Five units are required giving rise to a total cost of \$57,000. For duty of $31.4 \times 10^6 \frac{\text{BTU}}{\text{hr}}$ a direct fired furnace cost is estimated at \$125,400. Five units are required for a total cost of \$627,000.

The distillation column is assumed to be of sieve plate type with 24" tray spacings. Total feed rate to this column is $32200 \frac{\text{lb-moles}}{\text{hr}}$. For this highly non-ideal system of acetone-water the flow decreases down the column as shown in the analysis given by King (6).

Hence the column is sized according to the flow at the top. Ten columns handle the total volume at $3220 \frac{\text{lb mole}}{\text{hr}}$ each.

At column top

$$\text{Liquid flow } L = 0.3 \times 0.457 \times 3220 = 41.45 \frac{\text{lb-moles}}{\text{hr}}$$

$$\text{Vapor flow } V = 1.3 \times 0.457 \times 3220 = 1913.00 \frac{\text{lb-moles}}{\text{hr}}$$

$$\text{Density of vapor } (\rho_G) = 0.124 \text{ lb/ft}^3$$

$$\text{Density of liquid } (\rho_L) = 48.59 \text{ lb/ft}^3$$

Hence

$$\frac{L}{V} \left(\frac{\rho_G}{\rho_L} \right)^{1/2} = 0.0117$$

$$V(\rho_G)^{-1/2} = 1086.93$$

From the correlation for flooding limits in perforated columns given in King (6)

$$U_{\text{flood}} \left(\frac{\rho_G}{\rho_L - \rho_G} \right)^{1/2} = 0.39$$

where

$$U_{\text{flood}} = \text{flooding gas velocity}$$

- per unit time per unit active tray area

or

$$U_{\text{flood}} = 73.5 \frac{\text{lb-moles}}{\text{ft}^2 \text{ hr}}$$

For 85% flooding and 70% of tower cross-section active area

$$\text{Tower cross-section} = \frac{1913.00}{73.5 \times 0.58 \times 0.70} = 64.0 \text{ ft}^2$$

$$\therefore \text{ Tower diameter} = 9.04 \text{ ft}$$

Hence

A column with 9.04 ft diameter and 23 sieve trays with spacing of 24" is required for this separation. Cost of the sieve plate column is estimated from reference (2) and updated according to Marshall Stevens Cost Index. The purchased cost as of December 1973 is estimated at \$43,000. Ten columns are required for the total cost of \$430,000.

The raw material and the major utilities costs for the enzyme make up section are shown in Tables 16 and 17 respectively.

Pretreatment

885 tons/day of waste paper (6% moisture) is to be reduced to -200 mesh size for processing requirements. Personal communications with representatives of Empire Equipment Corporation, Pasadena, California resulted in the choice of size reduction equipment.

Paper shredder of capacity 5000-8000 lbs/hr is available with direct connected 75 HP, 3600 r.p.m. motor. The feed opening is 23" x 32" and it is also provided with shaft mounted blower and air system with cyclone. The unit cost is \$22,000. Ten units are required for a total cost of \$220,000.

Hammermill of capacity 5000-8000 lbs/hr is provided with shaft mounted blower, feed hopper and air system with cyclone. The mill is attached to a direct connected 90 HP 3600 r.p.m. motor. The unit cost for

TABLE 16

Raw Material Costs

Raw Material	Consumption rate	Manufacturer	Unit Cost	Cost/day
Superphosphate	19,500 lbs/day	Stauffer Chemicals Richmond, Calif.	\$0.02/lb	\$390
Proflo Oil	3250 lbs/day	Traders Oil Mill Fort Worth, Texas	\$0.10/lb	\$325
Acetone	2.38 T/day	Stauffer Chemicals Richmond, Calif.	\$0.069/lb	\$328.3
			TOTAL COST	<u>\$1043.30</u>

TABLE 17

Major Utilities Costs in Enzyme Make Up Section (Ref. 2)

Item	Amount Used	Unit Cost	Cost/day
Power input to fermentors	810 HP	\$0.0075/kwhr	\$108.81
Power input to compressors	881.1 HP	"	118.36
Power input to mixing tank	27.0 HP	"	3.61
Cooling water	$52.02 \times 10^4 \frac{\text{gallons}}{\text{hr}}$	0.01/1000 gallons	97.50
Process Steam (120 psig)	$4.59 \times 10^4 \frac{\text{lbs}}{\text{hr}}$	0.325/1000 lbs	321.00
		TOTAL COST	\$649.28/day

such a mill is \$24,000. Ten units are required for a total cost of \$240,000.

Screw conveyors are used to transport the solids to the induction vessel. Maximum capacity of 400 ft³/hr corresponds to 10" diameter of heights. Drive horsepower for 30' length is 1.69 HP. The unit cost for the conveyor is \$2750. Five units are required for a total cost of \$13,750.

Feed to the induction vessel is milled in a 3000 lbs/hr capacity mill manufactured by the Empire Equipment Company. This is coupled with a 40 HP motor and the cost of this unit is \$22,000.

The major utilities in the pretreatment section is the power input to the size reduction vessels. This is equal to 1134 KW or \$204.5/day.

APPENDIX B

Calibration Curve for Solid Feeder

Feed: Solka Floc (Brown Company, Providence, R. I.).

Variable Speed Transmission Setting	Feed Rate (mg/minute)
100	9.38
100	9.80
300	21.90
300	22.00
600	33.00
600	35.18
800	50.74
800	53.10

Calibration Curve for Rotameter

Flow medium: air at 70°F and 14.7 psia

Rotameter Model No. 603
Tube: R-2-15-13
Float: Stainless Steel
Matheson Co., Inc., E. Rutherford, N.J.

The calibration curve is shown in Figure 38.

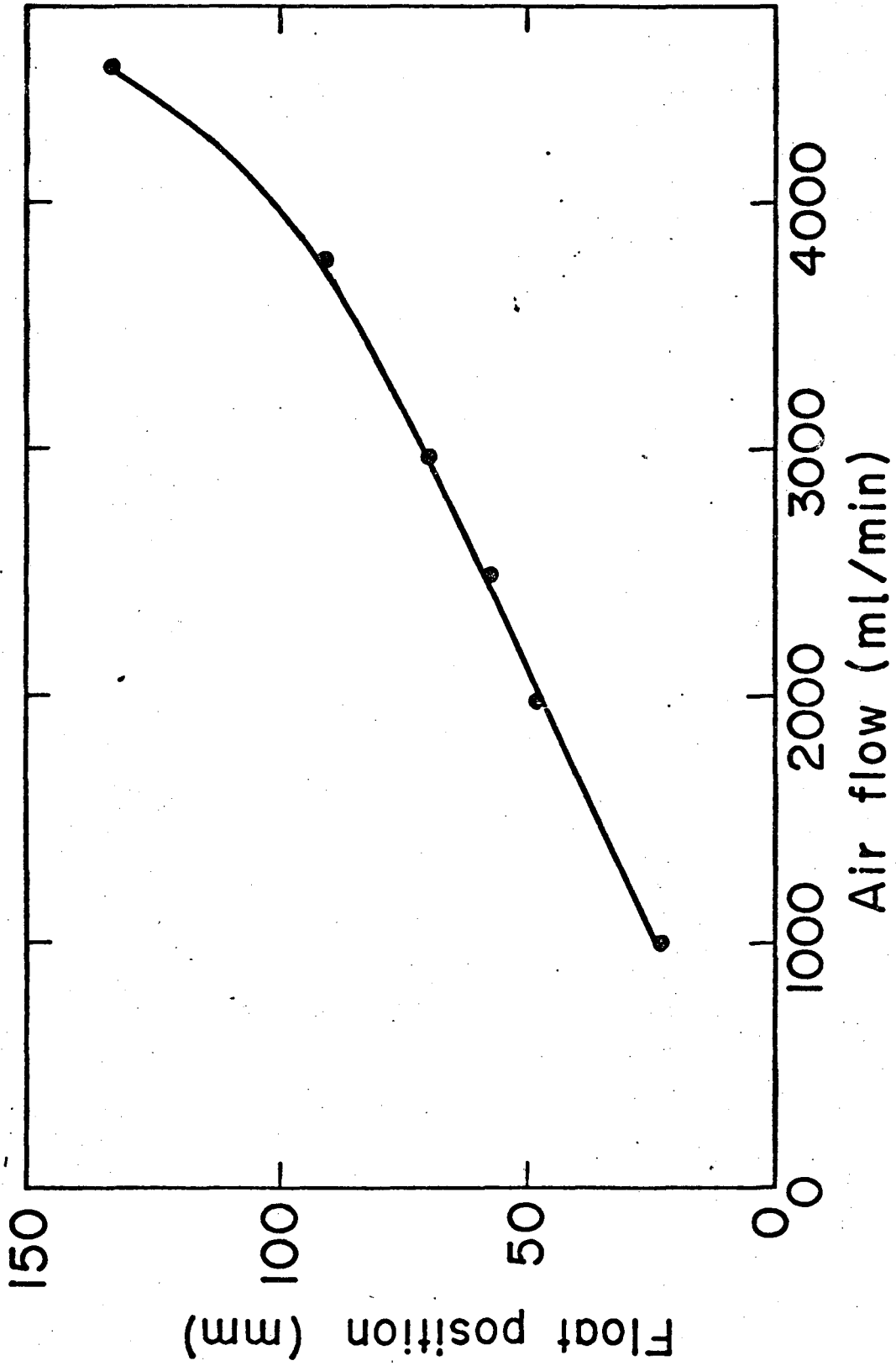

XBL7312-7037

Literature Cited

1. Calderbank, P. H., and M. B. Moo-Young, Chem. Eng. Sci., 16 39 (1961).
2. Chilton, C. H. (ed), "Cost Engineering in the Process Industries," McGraw-Hill, 1960.
3. Aries, R. S., and R. D. Newton, "Chemical Engineering Cost Estimation," McGraw-Hill, 1955.
4. Peters, M. S., and K. D. Timmerhaus, "Plant Design Economics for Chemical Engineers," Second Ed., McGraw-Hill, 1968.
5. Treybal, R. E., "Mass Transfer Operations, Second Ed., p. 401, McGraw-Hill, 1968.
6. King, C. J., "Separation Processes," p. 342 & 548, McGraw-Hill, 1971.
7. Michael, B. J., and S. A. Miller, AIChE J., 8, 262 (1962).
8. Ige, R., Masters thesis in progress, Dept. of Chem. Eng., Univ. of California, Berkeley.
9. Perry, J., Chemical Engineering Handbook, Fourth Ed., McGraw-Hill (Publisher).
10. Aiba, S., A. E. Humphrey, and N. F. Millis, 'Biochemical Engineering,' Chapter 8, Academic Press (Publisher).

LEGAL NOTICE

This report was prepared as an account of work sponsored by the United States Government. Neither the United States nor the United States Atomic Energy Commission, nor any of their employees, nor any of their contractors, subcontractors, or their employees, makes any warranty, express or implied, or assumes any legal liability or responsibility for the accuracy, completeness or usefulness of any information, apparatus, product or process disclosed, or represents that its use would not infringe privately owned rights.

TECHNICAL INFORMATION DIVISION
LAWRENCE BERKELEY LABORATORY
UNIVERSITY OF CALIFORNIA
BERKELEY, CALIFORNIA 94720