

# Lawrence Berkeley National Laboratory

## Recent Work

### Title

Relating the Microcosm Simulations to Full-Scale Grid Simulations

### Permalink

<https://escholarship.org/uc/item/4hr341n8>

### Authors

Undrill, J  
Mackin, P  
Ellis, J

### Publication Date

2018-02-13

Peer reviewed

# Relating the Microcosm Simulations to Full-Scale Grid Simulations

Authors:

**John Undrill<sup>1</sup>, Peter Mackin,<sup>2</sup> and Jeffrey Ellis<sup>2</sup>**

<sup>1</sup>John Undrill, LLC

<sup>2</sup>Utility Systems Efficiencies, Inc.

**Energy Analysis and Environmental Impacts Division  
Lawrence Berkeley National Laboratory**

**February 2018**



This work was supported by the Federal Energy Regulatory Commission, Office of Electric Reliability, under interagency Agreement #FERC-16-I-0105, and in accordance with the terms of Lawrence Berkeley National Laboratory Contract No. DE-AC02-05CH11231 with the U.S. Department of Energy.

## **Disclaimer**

This document was prepared as an account of work sponsored by the United States Government. While this document is believed to contain correct information, neither the United States Government nor any agency thereof, nor The Regents of the University of California, nor any of their employees, makes any warranty, express or implied, or assumes any legal responsibility for the accuracy, completeness, or usefulness of any information, apparatus, product, or process disclosed, or represents that its use would not infringe privately owned rights. Reference herein to any specific commercial product, process, or service by its trade name, trademark, manufacturer, or otherwise, does not necessarily constitute or imply its endorsement, recommendation, or favoring by the United States Government or any agency thereof, or The Regents of the University of California. The views and opinions of authors expressed herein do not necessarily state or reflect those of the United States Government or any agency thereof, or The Regents of the University of California.

Ernest Orlando Lawrence Berkeley National Laboratory is an equal opportunity employer.

## **Copyright Notice**

This manuscript has been authored by an author at Lawrence Berkeley National Laboratory under Contract No. DE-AC02-05CH11231 with the U.S. Department of Energy. The U.S. Government retains, and the publisher, by accepting the article for publication, acknowledges, that the U.S. Government retains a non-exclusive, paid-up, irrevocable, worldwide license to publish or reproduce the published form of this manuscript, or allow others to do so, for U.S. Government purposes.

# Relating the Microcosm Simulations to Full-Scale Grid Simulations

Prepared for the  
Office of Electric Reliability  
Federal Energy Regulatory Commission

## **Principal Author**

John Undrill, John Undrill, LLC  
Peter Mackin and Jeffrey Ellis, Utility Systems Efficiencies, Inc.

Ernest Orlando Lawrence Berkeley National Laboratory  
1 Cyclotron Road, MS 90R4000  
Berkeley CA 94720-8136

LBNL-2001106

February 2018

The work described in this study was funded by Federal Energy Regulatory Commission, Office of Electric Reliability, under interagency Agreement #FERC-16-I-0105, and in accordance with the terms of Lawrence Berkeley National Laboratory Contract No. DE-AC02-05CH11231 with the U.S. Department of Energy.

## Acknowledgements

The work described in this study was funded by the Federal Energy Regulatory Commission (FERC), Office of Electric Reliability, under interagency Agreement #FERC-16-I-0105, and in accordance with the terms of Lawrence Berkeley National Laboratory Contract No. DE-AC02-05CH11231 with the U.S. Department of Energy. The authors acknowledge project management provided by Eddy Lim, FERC Office of Electric Reliability.

The authors thank Hongming Zhang and Terry Baker at Peak Reliability (PeakRC), Julia Matevosyan at the Electric Reliability Council of Texas (ERCOT), and Raja Thappetaobula at the Midwest Independent System Operator (MISO) for providing information on each of the three U.S. interconnections that was used as a basis for aspects of the operating conditions that we studied using simulation tools.

The authors thank Sydney Niemeyer, NRG Energy (retired) and Julia Matevosyan, Electric Reliability Council of Texas for review comments on an early draft of this report.

All opinions, errors, and omissions remain the responsibility of the authors. All reference URLs were accurate as of February 2018.

# Table of Contents

|   |           |
|---|-----------|
| Acknowledgements.....   | i         |
| Table of Contents.....  | ii        |
| Table of Figures.....   | iii       |
| List of Tables .....  | iii       |
| Acronyms and Abbreviations.....   | iv        |
| <b>1. Objective .....</b>   | <b>1</b>  |
| <b>2. Relationship of the Microcosm Model to Large-Scale Simulation Models.....</b> | <b>1</b>  |
| 2.1 The Microcosm Simulation Model .....  | 1         |
| 2.2 Matching a Microcosm Simulation to Standard System-Wide Simulations .....       | 3         |
| 2.3 Sources of Data .....   | 4         |
| <b>3. Comparisons of Microcosm and Large-Scale Simulations.....</b>                 | <b>6</b>  |
| 3.1 Texas Interconnection.....  | 6         |
| 3.2 Western Interconnection.....  | 11        |
| 3.3 Eastern Interconnection.....  | 14        |
| <b>4. Commentary .....</b>  | <b>18</b> |
| <b>5. References.....</b>   | <b>19</b> |

# Table of Figures

- Figure 1. Generation elements of the microcosm model ..... 1
- Figure 2. Construction of the microcosm model from fleet makeup data ..... 2
- Figure 3. ERCOT simulation case 1: PSS/E..... 6
- Figure 4. ERCOT inertia data provided by ERCOT ..... 8
- Figure 5. ERCOT simulation case 1: Microcosm..... 10
- Figure 6. ERCOT parameter variations..... 10
- Figure 7. WECC simulation case 1: PSLF..... 11
- Figure 8. WECC simulation case 1: Microcosm ..... 13
- Figure 9. WECC parameter variations..... 13
- Figure 10. EI simulation case 1: PSS/E ..... 14
- Figure 11. EI simulation case 1: Microcosm..... 16
- Figure 12. EI parameter variations..... 16
- Figure 13. EI simulation of 'Rockport' event: loss of 4600MW over 9 seconds ..... 17

# List of Tables

- Table 1. Summary of base case models used for large-scale simulations ..... 5
- Table 2. Fleet makeup for microcosm simulation: ERCOT..... 9
- Table 3. Summary and result of microcosm simulation: ERCOT..... 9
- Table 4. Fleet makeup for microcosm simulation: WECC..... 12
- Table 5. Summary and result of microcosm simulation: WECC..... 12
- Table 6. Fleet makeup for microcosm simulation: EI..... 15
- Table 7. Summary and result of microcosm simulation: EI ..... 15
- Table 8. Adjusted fleet makeup for microcosm simulation to match the 'Rockport' event ..... 18

## Acronyms and Abbreviations

|           |  |
|-----------|--|
| CCGT      | Combined-cycle gas turbine                                     |
| CCST      | Combined-cycle steam turbine                                   |
| ERCOT     | Electric Reliability Council of Texas                          |
| FMW       | Fleet MW of the grouping; the total real power produced, in MW |
| GT        | gas turbine  |
| GVA       | Generator electrical capability                                |
| HRSR      | Heat Recovery Steam Generator                                  |
| Hz        | Hertz  |
| LBNL      | Lawrence Berkeley National Laboratory                          |
| MVAT      | Total connected generator, complex power capability, MVA       |
| MW        | Megawatt   |
| MWCT      | Total connected prime mover capability, MW                     |
| MWST      | Stored inertial energy at rated speed, MW-sec                  |
| Rfrac, Rf | Responsive fraction  |
| Sfrac, Sf | Responsive-sustaining fraction                                 |
| WECC      | Western Electricity Coordinating Council                       |



# 1. Objective

This report is an addendum to Undrill 2018b1. It compares simulations made with the microcosm power system model described in Undrill 2018a2 and Undrill 2018b, with full scale grid simulation programs made with the PSS/E and PSLF simulation programs.

## 2. Relationship of the Microcosm Model to Large-Scale Simulation Models

### 2.1 The Microcosm Simulation Model

The microcosm model described in the accompanying report (Undrill 2018a) considers the dynamic behavior of eleven classes of generation connected to a single-point electric system as shown in Figure 1. The generation in each class is represented by a single generator, excitation system, prime mover and plant level secondary controller. Renewable generation is treated as contributing constant real power but no inertial response to the system and, accordingly, is represented as negative electrical load.

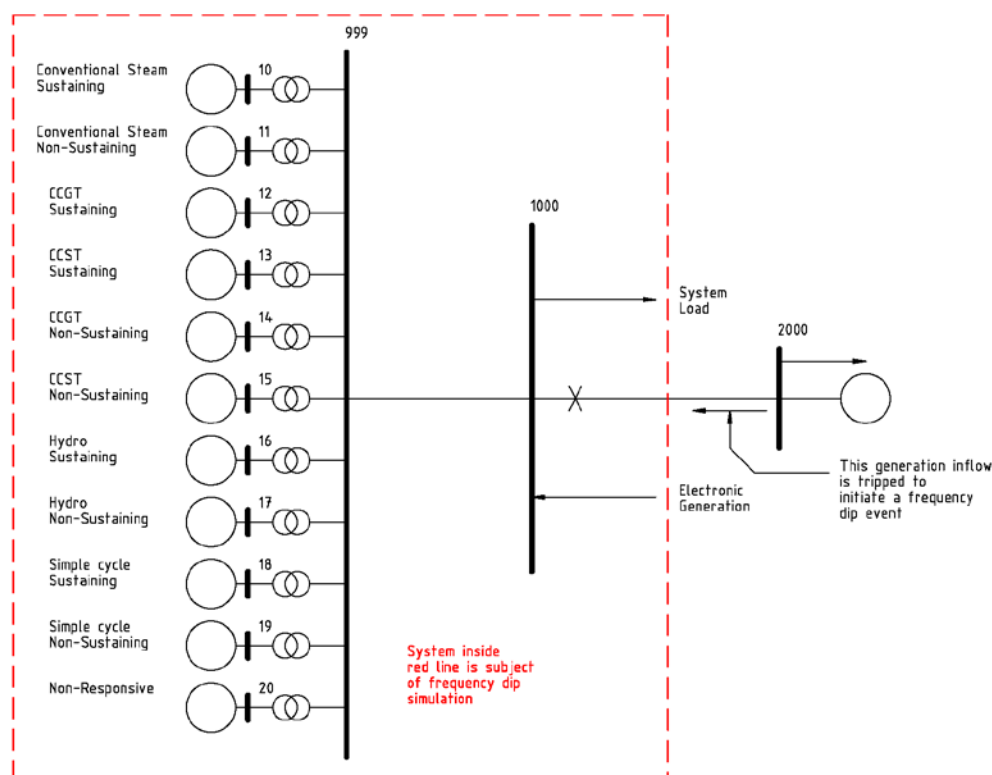
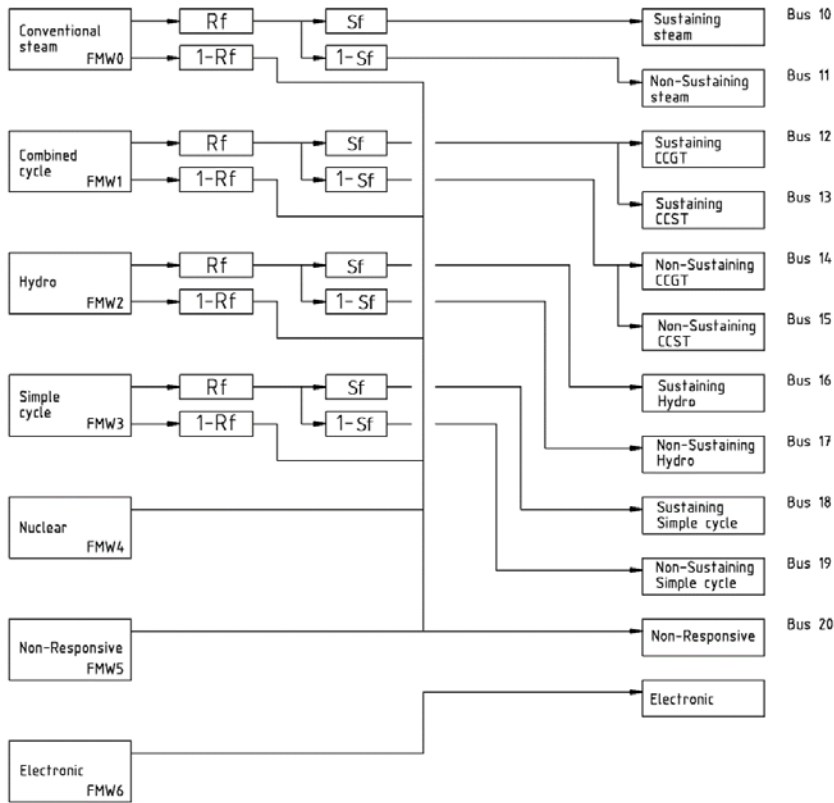

**Figure 1. Generation elements of the microcosm model**

<sup>1</sup> Undrill, J.M. (2018b): *Primary Frequency Response and Control of Power System Frequency*.

<sup>2</sup> Undrill, J.M. (2018a): *Microcosm Model for Simulation of Power System Frequency Dip Transients: Program Manual*.

Each of the first ten synchronous generating units represents the totaled behavior of a particular type of synchronous generating unit in a particular operating mode. The types and operating modes are shown in Figure 2.



**Figure 2. Construction of the microcosm model from fleet makeup data**

The electrical parameters of the generators and electrical system are assigned *pro forma* values chosen to ensure that:

- the eleven turbine generators are firmly synchronized with one-another
- there is sufficient electric power transfer capacity to convey the power produced by the prime movers to the load

The MVA ratings, MW ratings, and inertia constants of the turbine-generators and the frequency dependence characteristics of load are important parameters in the simulation model; other electrical characteristics are important only in relation to the assurances noted above.

The prime-mover and secondary control models assigned to the eleven classes of prime mover are the focus of interest in simulations made with the microcosm model. The model is implemented in the PSLF program and uses the standard prime-mover and control models available in that program. In keeping with the minimal electric system modeling, the description of the model is made in terms of real power

generation; transmission losses are considered to be part of the total system load.

The individual prime mover models in the microcosm system model are populated by preassigned parameters that are typical of the classes of power plant that they represent, but contain only *pro forma* values of turbine capability, inertia constant, and generator MVA. These pro-forma characterizations of size and operating mode are replaced each time a simulation is executed by reading and applying fleet description parameters as described below.

After the simulation has been prepared, details of the individual dynamic models can be viewed and modified by the standard facilities of the PSLF program and its EPCL programming language.

## 2.2 Matching a Microcosm Simulation to Standard System-Wide Simulations

The setup of the microcosm model is based on the grouping of generation types as follows:

|   |  |
|---|--|
| 0 | steam (conventional)                       |
| 1 | combined cycle (including GT and ST parts) |
| 2 | hydro                                      |
| 3 | simple cycle                               |
| 4 | nuclear                                    |
| 5 | nonresponsive (synchronous)                |
| 6 | electronic                                 |

The generation fleet is described by stating the fraction of the total real power production, including that of electronically coupled generations, provided by each of the seven generation types. The power fractions assigned to these classes must add up unity.

For each class of turbine-generator there must be specified:

|       |  |
|-------|--|
| FMW   | The fraction of the total real power produced by the generation assigned to the group  |
| Rfrac | Responsive fraction. The fraction of the generation in the class that is initially responsive to change of frequency         |
| Sfrac | Sustaining fraction. The fraction of the responsive generation in the class that sustains its initial change in power output |

The relationship between the groupings of generation by type and the generation classes of the microcosm model is illustrated by Figure 2.

The steps required to relate the microcosm model to a large-scale simulation, or to reality are:

- a. Work from a data base that describes to real power output and type of every generating unit that is on-line in the system condition of interest.
- b. Identify the type, such as conventional steam, combined cycle, or hydro, of each generating unit.

- c. Group the generating units by type, into the seven generation groupings identified above, and obtain the following for each grouping:
  - Total real power produced, MW
  - Total connected generator MVA capability
  - Total connected prime mover real power capability, MW
  - Stored inertial energy at rated speed, MW-sec
- d. Determine by examination of parameters, if possible, or otherwise estimate the fraction of the generation in each grouping that is responsive to change of system frequency. This fraction is referred to as the Responsive fraction (Rfrac, or Rf).
- e. Determine by examination of parameters, if possible, or otherwise estimate the fraction of the responsive part of each grouping's generation that sustains its initial response to a discrete disturbance of frequency. This fraction is referred to as the Sustaining fraction (Sfrac, or Sf).
- f. Enter the values gleaned for the above parameters into the fleet data file (described in the accompanying manual).
- g. Execute the control program to run a simulation.

Sample fleet data files containing the above data for the three interconnections are shown in Table 2, Table 4, and Table 6. The details of the file format are described in the operating manual of the microcosm model (Undrill 2018a).

## 2.3 Sources of Data

Simulations of each of the three U.S. interconnections were made with the microcosm simulation model and compared with large-scale simulations made with the PSS/E and PSLF grid simulation programs. The parameters used in the microcosm model were based, to the extent that proved to be possible and meaningful, on data gleaned from the PSS/E and PSLF base cases cited Table 1.

The totals of generator electrical capability (GVA) and turbine real power capability (GW) shown in the table were gleaned from examination of the load flow cases and of the associated dynamic simulation data files.

The table shows the system level values of the Responsive fractions (Rfrac) and Sustaining fractions (Sfrac) used to describing the overall operating modes of the generation in each system. These overall fractions were calculated from the values assigned to these fractions for each of the seven generation classes. The PSS/E and PSLF data bases provide only minimal information on power plant operating modes.

Accordingly, the Responsive and Sustaining fractions for the generation groups had to be estimated initially and then tuned in trial simulations with the microcosm model. Initial estimates of the fractions, Rfrac and Sfrac, allocating generation to responsive, and responsive-sustaining operation were made on the basis of experience with the several types of plants.

It must be noted that the parameters shown in Table 1 do not purport to indicate the totals and fractions that exist in the interconnections in reality. Rather, these totals and fractions describe the simulations that have been made with the two full-scale programs.

**Table 1. Summary of base case models used for large-scale simulations**

| Year  | File | Total             | Total | Total | Total  | Synch   | Rf      | Sf   | Nf   | Ef   | Gen  |        |
|-------|------|-------------------|-------|-------|--------|---------|---------|------|------|------|------|--------|
|       |      | Synch             | Real  | Synch | Synch  | Reserve |         |      |      |      | Loss |        |
|       |      | Gen               | Power | Power | Capac. |         |         |      |      |      |      |        |
|       |      | GVA               | GW    | GW    | GW     | GW      | Rf      | Sf   | Nf   | Ef   |      |        |
|       |      | D                 | E     | F     | G      | H       |         |      |      |      |      |        |
| EI    | 2018 | MMWG_2016SUM_2015 | 878.0 | 665.6 | 657.7  | unclear | unclear | 0.67 | 0.66 | 0.32 | 0.01 | 0.007  |
| ERCOT | 2018 | NT2018-2015       | 56.8  | 43.3  | 28.2   | 52.2    | 24.0    | 0.65 | 0.52 | 0.05 | 0.30 | 0.0625 |
| WECC  | 2018 | 18LW2             | 168.6 | 99.0  | 4.0    | 120.0   | 17.0    | 0.79 | 0.57 | 0.17 | 0.04 | 0.0276 |

### 2.3.1 The Texas Interconnection (ERCOT)

Generation types were deduced from the names of governor dynamic models associated with the generators. The PSS/E data base does not include explicit identification of prime mover type and so the deduction was based on assumed correspondence with dynamic models with the types of interest. For example, it was assumed that ERCOT uses the ggov1 model for steam turbines and that the ucggt model (which is a 'user written' model) is indicative of a gas turbine in a combined cycle.

Examination of the wind turbine models in the ERCOT data base indicated that a large fraction of the wind power plants in Texas are type 1 machines and, accordingly, that the wind fleet contributes a significant, but unknown, amount of rotating inertia to the ERCOT system. The system inertia constant used for the rotating synchronous part of the ERCOT fleet is 3.8 seconds, (see Figure 4). This inertia constant value has been augmented by trial-and-error to achieve a fair match between the initial rate of frequency decline and the timing of the frequency nadir as indicated by the microcosm model and by the simulation in PSS/E.

### 2.3.2 The Western Interconnection (WECC)

Generation types were deduced on the basis of the turbine governor model name as follows:

|                                |   |
|--------------------------------|---|
| conventional steam             | ieeeg1, tgov1   |
| gas turbine and combined cycle | ggov1, ggov3  |
| hydro                          | hygov, hygov4, hygovr, ieeeg3, hyg3, gpwsc, pidgov, g2wsc |

### 2.3.3 The Eastern Interconnection

Generation type was determined on the basis of the turbine governor model names. There was a high degree of uncertainty in the identification of prime mover types and operating modes. It is suspected that the data base indicates larger fraction of generation to be responsive and responsive-sustaining than exists in reality. (This point is addressed further in Section 3.3.2.)

### 3. Comparisons of Microcosm and Large-Scale Simulations

#### 3.1 Texas Interconnection

Simulations of the Texas Interconnection in the PSS/E program consider the instantaneous loss of 2750 MW, resulting from the trip of both units of the South Texas Nuclear plant. The response of frequency as simulated by PSS/E is shown by the dashed trace in Figure 3.

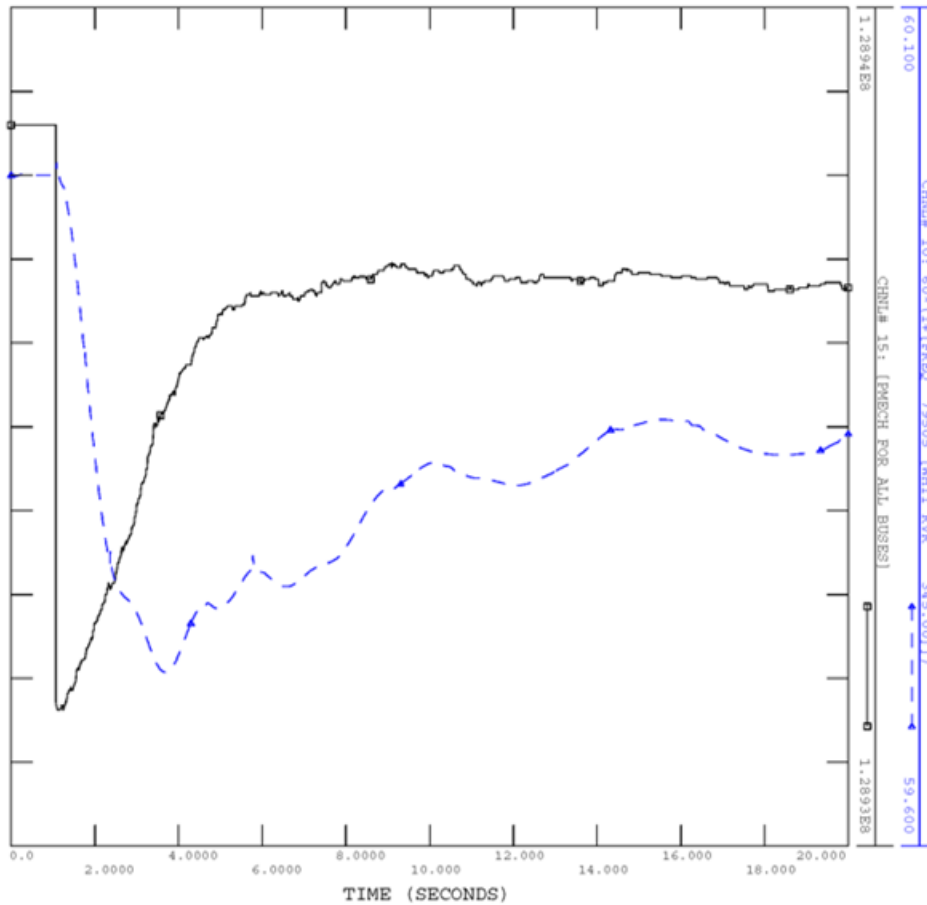

Figure 3. ERCOT simulation case 1: PSS/E

The following have been gleaned from examination of the initial condition load flow solution and the associated dynamics data file:

|  |           |
|--|-----------|
| Total generation output                            | 43341 MW  |
| Total synchronous generation output                | 28226 MW  |
| Total asynchronous generation output               | 15117 MW  |
| Total connected synchronous generation MVA         | 56807 MVA |
| Total connected synchronous prime mover capability | 52208 MW  |

Based on the above, the fleet makeup has been set up for the microcosm model with the generation grouped as the following fractions of the system total:

|   |                                       |        |
|---|---------------------------------------|--------|
| 0 | Coal/gas steam generation output      | 0.32   |
| 1 | Comb. cycle generation (GT+ST) output | 0.16 W |
| 2 | Hydro generation output               | 0.02   |
| 3 | Simple cycle GT generation output     | 0.16   |
| 4 | Nuclear generation output(post-trip)  | 0.04   |
| 5 | Nonresponsive generation              | 0.00   |
| 6 | Wind + solar generation output        | 0.30   |

The inertia constant used in the microcosm simulation of ERCOT is based on generator dispatch and inertia data provided by ERCOT separately from the inertia constant values contained in the PSS/E data file. The tabulation of this data is shown in Figure 4.

The data file specifying the setup of the microcosm simulation is shown in Table 2. The summary of the microcosm simulation is shown in Table 3.

|                   | Coal fired conventional steam |                 |                        | Gas fired conventional steam |                 |                        | Gas turbine in combined cycle |                 |                        | Steam turbine in combined cycle |                 |                        | Heavy duty GT in simple cycle |                 |                        | Aeroderiv GT in simple cycle |                 |                        | EFls line H                          |      |       |      |       |       |      |      |      |       |      |       |       |       |
|-------------------|-------------------------------|-----------------|------------------------|------------------------------|-----------------|------------------------|-------------------------------|-----------------|------------------------|---------------------------------|-----------------|------------------------|-------------------------------|-----------------|------------------------|------------------------------|-----------------|------------------------|--------------------------------------|------|-------|------|-------|-------|------|------|------|-------|------|-------|-------|-------|
|                   | Power<br>produced<br>MVA      | No. of<br>units | Total<br>MW<br>seconds | Power<br>produced<br>MVA     | No. of<br>units | Total<br>MW<br>seconds | Power<br>produced<br>MVA      | No. of<br>units | Total<br>MW<br>seconds | Power<br>produced<br>MVA        | No. of<br>units | Total<br>MW<br>seconds | Power<br>produced<br>MVA      | No. of<br>units | Total<br>MW<br>seconds | Power<br>produced<br>MVA     | No. of<br>units | Total<br>MW<br>seconds | Total MW-sec<br>divided by total MVA |      |       |      |       |       |      |      |      |       |      |       |       |       |
| 07/13/20 16:18:15 | 18826                         | 32              | 61513                  | 2.63                         | 3093            | 6697                   | 23                            | 18039           | 5.06                   | 141                             | 137563          | 5.06                   | 5427                          | 13309           | 57                     | 57569                        | 4.33            | 943                    | 4764                                 | 53   | 23495 | 4.33 | 463   | 737   | 8    | 1668 | 2.26 | 3.639 |      |       |       |       |
| 07/14/20 16:18:15 | 18364                         | 32              | 61513                  | 2.63                         | 3495            | 6421                   | 31                            | 24132           | 2.67                   | 17605                           | 27388           | 143                    | 138616                        | 5.06            | 6880                   | 13416                        | 58              | 57753                  | 4.30                                 | 954  | 4663  | 54   | 22109 | 4.72  | 766  | 1223 | 15   | 2245  | 1.84 | 3.900 |       |       |
| 08/01/20 16:18:00 | 16803                         | 30              | 57076                  | 2.61                         | 5568            | 10365                  | 35                            | 26275           | 2.62                   | 17381                           | 27076           | 144                    | 138775                        | 5.05            | 6464                   | 13122                        | 57              | 56508                  | 4.31                                 | 1413 | 5318  | 67   | 26562 | 4.39  | 311  | 562  | 7    | 1359  | 2.33 | 3.925 |       |       |
| 08/08/20 16:19:00 | 16404                         | 2716            | 31                     | 59333                        | 2.61            | 9064                   | 11975                         | 40              | 34185                  | 2.65                            | 18231           | 26292                  | 150                           | 145937          | 5.05                   | 8241                         | 14074           | 61                     | 60177                                | 4.28 | 1102  | 4668 | 48    | 22613 | 4.89 | 662  | 1295 | 16    | 2327 | 1.80  | 3.676 |       |
| 08/11/20 16:19:00 | 16245                         | 22716           | 31                     | 59333                        | 2.61            | 5760                   | 11691                         | 39              | 34203                  | 2.63                            | 18132           | 26254                  | 150                           | 146848          | 5.06                   | 8368                         | 14218           | 62                     | 60697                                | 4.28 | 1270  | 5132 | 52    | 25060 | 4.88 | 656  | 1295 | 16    | 2327 | 1.80  | 3.907 |       |
| 07/22/20 16:15:15 | 18303                         | 22729           | 31                     | 59600                        | 2.62            | 8534                   | 12122                         | 46              | 35040                  | 2.69                            | 18055           | 27817                  | 149                           | 140516          | 5.05                   | 9855                         | 13811           | 59                     | 58659                                | 4.26 | 1442  | 5267 | 57    | 25720 | 4.87 | 581  | 1016 | 12    | 1958 | 1.97  | 3.686 |       |
| 08/03/20 16:14:00 | 17764                         | 21696           | 30                     | 57076                        | 2.61            | 9096                   | 13375                         | 48              | 37949                  | 2.64                            | 17782           | 27279                  | 148                           | 137676          | 5.05                   | 6737                         | 13412           | 59                     | 57174                                | 4.26 | 1696  | 5691 | 61    | 27032 | 4.75 | 943  | 1579 | 20    | 2660 | 1.69  | 3.642 |       |
| 08/05/20 16:14:00 | 16993                         | 21213           | 29                     | 55184                        | 2.60            | 9154                   | 13406                         | 47              | 38027                  | 2.64                            | 18232           | 26274                  | 149                           | 142802          | 5.05                   | 6978                         | 14210           | 60                     | 60895                                | 4.29 | 1851  | 5696 | 60    | 27877 | 4.89 | 599  | 1024 | 12    | 2001 | 1.96  | 3.698 |       |
| 09/08/20 16:13:25 | 18222                         | 22716           | 31                     | 59333                        | 2.61            | 7792                   | 13139                         | 45              | 37162                  | 2.65                            | 16425           | 26533                  | 152                           | 144190          | 5.05                   | 9551                         | 14366           | 62                     | 61625                                | 4.29 | 1196  | 4602 | 51    | 23666 | 4.83 | 678  | 1147 | 15    | 2022 | 1.76  | 3.688 |       |
| 09/19/20 16:15:00 | 16865                         | 22602           | 31                     | 59236                        | 2.62            | 8637                   | 13704                         | 47              | 39370                  | 2.67                            | 17961           | 27508                  | 150                           | 138003          | 5.02                   | 6928                         | 14107           | 62                     | 60075                                | 4.26 | 1660  | 5547 | 63    | 27504 | 4.96 | 1048 | 1723 | 22    | 2824 | 1.64  | 3.693 |       |
| 10/23/20 16:02:00 | 7104                          | 22232           | 30                     | 58023                        | 2.61            | 16                     | 633                           | 7               | 1566                   | 2.47                            | 3019            | 7632                   | 45                            | 36736           | 5.06                   | 774                          | 2556            | 15                     | 11818                                | 4.62 | 463   | 3563 | 42    | 17518 | 4.82 | 0    | 0    | 0     | 0    | 0     | 0     | 3.467 |
| 11/17/20 16:02:50 | 6800                          | 19195           | 26                     | 49837                        | 2.60            | 30                     | 798                           | 8               | 1882                   | 2.46                            | 2264            | 7292                   | 41                            | 37598           | 5.16                   | 1004                         | 3475            | 18                     | 17249                                | 4.96 | 538   | 3437 | 39    | 16004 | 4.80 | 0    | 0    | 0     | 0    | 0     | 0     | 3.607 |
| 11/27/20 16:02:30 | 5009                          | 16372           | 23                     | 40732                        | 2.61            | 152                    | 1258                          | 9               | 2562                   | 2.37                            | 2644            | 8786                   | 48                            | 46595           | 5.19                   | 781                          | 3167            | 16                     | 14662                                | 4.60 | 562   | 3569 | 41    | 17393 | 4.87 | 0    | 0    | 0     | 0    | 0     | 0     | 3.719 |
| 11/25/20 16:03:20 | 5869                          | 16644           | 23                     | 43207                        | 2.60            | 30                     | 798                           | 8               | 1882                   | 2.46                            | 3714            | 10473                  | 55                            | 54371           | 5.19                   | 1368                         | 4725            | 21                     | 21735                                | 4.60 | 598   | 3752 | 44    | 16275 | 4.87 | 0    | 0    | 0     | 0    | 0     | 0     | 3.637 |
| 11/27/20 16:03:55 | 5813                          | 18079           | 25                     | 47439                        | 2.62            | 30                     | 798                           | 8               | 1882                   | 2.46                            | 3008            | 9211                   | 50                            | 47127           | 5.12                   | 963                          | 3918            | 18                     | 17956                                | 4.58 | 606   | 3655 | 45    | 18914 | 4.91 | 25   | 142  | 2     | 350  | 2.46  | 3.673 |       |
| 10/01/20 16:04:35 | 12389                         | 21532           | 29                     | 58504                        | 2.62            | 265                    | 2433                          | 9               | 6198                   | 2.33                            | 4854            | 11116                  | 63                            | 56516           | 5.06                   | 1620                         | 4378            | 21                     | 20055                                | 4.56 | 558   | 3468 | 42    | 16968 | 4.90 | 0    | 0    | 0     | 0    | 0     | 0     | 3.639 |
| 11/06/20 16:02:25 | 9364                          | 18952           | 26                     | 49769                        | 2.63            | 30                     | 798                           | 8               | 1882                   | 2.46                            | 6169            | 13603                  | 69                            | 68302           | 5.02                   | 2433                         | 5099            | 24                     | 29934                                | 4.89 | 502   | 3286 | 38    | 15774 | 4.83 | 0    | 0    | 0     | 0    | 0     | 0     | 3.659 |
| 11/19/20 16:02:00 | 7871                          | 18907           | 27                     | 52157                        | 2.62            | 30                     | 798                           | 8               | 1882                   | 2.46                            | 7506            | 15097                  | 75                            | 74874           | 4.96                   | 3486                         | 7224            | 31                     | 33648                                | 4.86 | 562   | 3460 | 41    | 16670 | 4.83 | 0    | 0    | 0     | 0    | 0     | 0     | 3.660 |
| 11/13/20 16:01:00 | 8859                          | 18907           | 27                     | 52157                        | 2.62            | 31                     | 798                           | 8               | 1882                   | 2.46                            | 6236            | 12531                  | 64                            | 63663           | 5.08                   | 2781                         | 5979            | 25                     | 25961                                | 4.59 | 546   | 3400 | 41    | 16670 | 4.83 | 0    | 0    | 0     | 0    | 0     | 0     | 3.789 |
| 11/26/20 16:05:00 | 9870                          | 17327           | 24                     | 46119                        | 2.60            | 31                     | 798                           | 8               | 1882                   | 2.46                            | 5754            | 13010                  | 64                            | 64332           | 4.94                   | 2043                         | 5169            | 22                     | 24311                                | 4.68 | 637   | 3752 | 44    | 16275 | 4.87 | 0    | 0    | 0     | 0    | 0     | 0     | 3.644 |

Figure 4. ERCOT inertia data provided by ERCOT



**Table 2. Fleet makeup for microcosm simulation: ERCOT**

```

ChaPrefix      ercot-
I Type         FMW    Rf    Df
---- Fleet makeup
0 Steam        0.32  0.98  0.48
1 CCGT-G       0.16  0.98  0.58
2 Hydro         0.02  1.00  .95
3 SCGT         0.16  0.98  .48
4 Nuclear       0.04  .00   .00
5 Nonresp       0     .00   .00
6 Renewable    0.30  .00   .00
---- General settings
deltap         0.0625
H              5.4
kimw           0.001
lpd            1.
droop          0.04
gbasef         2.01
tbasef         1.85
---- Individual parameter settings
0 end

```

**Table 3. Summary and result of microcosm simulation: ERCOT**

| Type      | I | Ff   | Rf   | Df   | Qf   | Rmw    | Dmw    | Qmw    |
|-----------|---|------|------|------|------|--------|--------|--------|
| Steam     | 0 | 0.32 | 0.98 | 0.48 | 0.52 | 0.3136 | 0.1505 | 0.1631 |
| CCGT-G    | 1 | 0.16 | 0.98 | 0.58 | 0.42 | 0.1568 | 0.0909 | 0.0659 |
| Hydro     | 2 | 0.02 | 1.00 | 0.95 | 0.05 | 0.0200 | 0.0190 | 0.0010 |
| SCGT      | 3 | 0.16 | 0.98 | 0.48 | 0.52 | 0.1568 | 0.0753 | 0.0815 |
| Nuclear   | 4 | 0.04 | 0.00 | 0.00 | 1.00 | 0.0000 | 0.0000 | 0.0000 |
| Nonresp   | 5 | 0.00 | 0.00 | 0.00 | 1.00 | 0.0000 | 0.0000 | 0.0000 |
| Renewable | 6 | 0.30 | 0.00 | 0.00 | 1.00 | 0.0000 | 0.0000 | 0.0000 |

|                                  |     |       |
|----------------------------------|-----|-------|
| Total generation                 | = : | 10000 |
| Rotating synchronous generation  | = : | 7000  |
| Electronic generation            | = : | 3000  |
| System regulating fraction Rfrac | = : | 0.647 |
| Sustaining frac (of Rfrac) Dfrac | = : | 0.519 |
| Non-responsive fraction Nfrac    | = : | 0.053 |
| Electronic fraction Efrac        | = : | 0.300 |

|                             |     |        |
|-----------------------------|-----|--------|
| Responsive/sustaining MW    | = : | 3357.4 |
| Responsive/nonsustaining MW | = : | 3114.6 |
| Responsive - total MW       | = : | 6472.0 |
| Non-responsive - total MW   | = : | 528.0  |
| Renewable - total MW        | = : | 3000.0 |
| Minimum frequency (Hz)      | = : | 59.695 |

|                         |     |        |
|-------------------------|-----|--------|
| Gen loss fraction       | = : | 0.0625 |
| System inertia constant | = : | 5.4000 |
| Load control gain       | = : | 0.0010 |
| Load freq exponent      | = : | 1.0000 |
| Governing droop         | = : | 0.0400 |
| Gen MVA factor          | = : | 2.0100 |
| Turbine MW factor       | = : | 1.8500 |

Figure 5 shows the microcosm simulation of frequency for three variations on the fleet makeup given in Table 2 as follows:

- Red: Decrease Steam fraction of fleet by 0.05 pu/increase non-responsive fraction
- Green: Fleet fractions as given in Table 2
- Blue: Increase Steam fraction of fleet by 0.05 pu/decrease non-responsive fraction

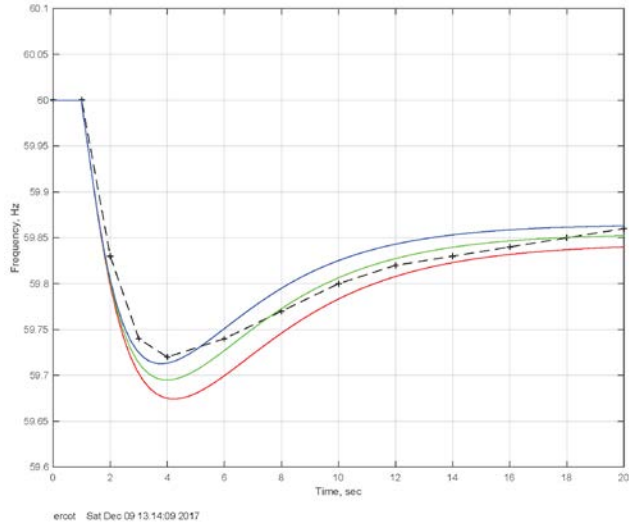

**Figure 5. ERCOT simulation case 1: Microcosm**

*Fleet makeup shown in Table 2*

*Red - 25 percent steam*

*Green - 30 percent steam*

*Blue - 35 percent steam*

*Black - Full-scale simulation*

Figure 6 illustrates the sensitivity of the frequency dip to variations of fleet makeup (Figure 6a) and fleet inertia constant (Figure 6b). For Figure 6a, the fraction of ERCOT generation in steam plants is varied  $\pm 0.05$  per unit and, for Figure 6b the overall inertia constant of the ERCOT rotating fleet is varied  $\pm 1.0$  second. (Note that Figure 6a is the same as Figure 5.)

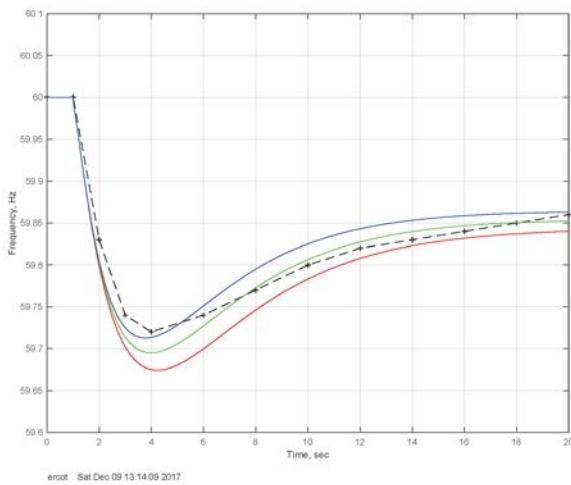

(a) Variation of fleet fraction in steam plants

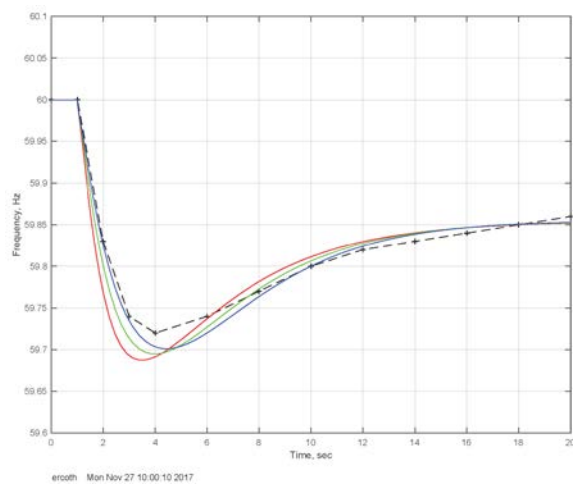

(b) Variation of overall inertia constant

**Figure 6. ERCOT parameter variations**

*(a)  $ff[0] \pm 0.05$*

*(b)  $hg \pm 1.0$*

### 3.2 Western Interconnection

Simulations of the Western Interconnection in the PSLF program considered the instantaneous loss of 2780 MW, resulting from the trip of two units of the Palo Verde Nuclear plant. The response of frequency as simulated by PSLF is shown in Figure 7. The following have been gleaned from examination of the initial condition load flow solution and the associated dynamics data file:

|   |            |
|---|------------|
| Total generation output                 | 99037 MW   |
| Total connected rotating generation MVA | 168631 MVA |

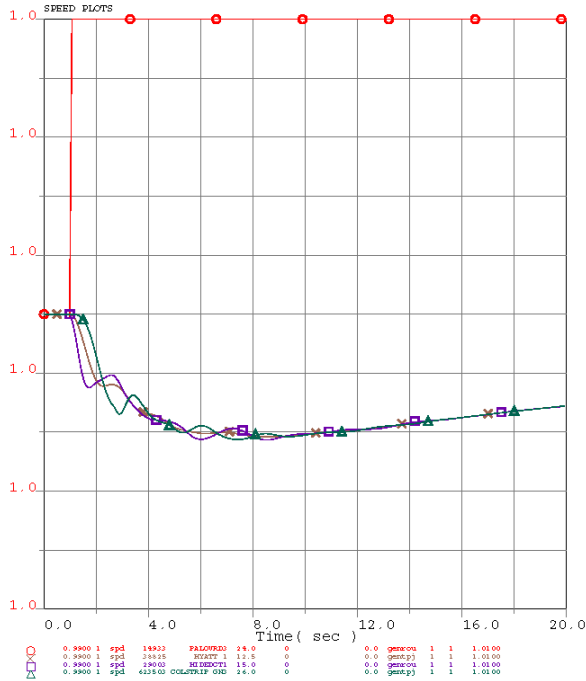

Figure 7. WECC simulation case 1: PSLF

Based on the above, the fleet makeup has been set up for the microcosm model with the generation grouped as the following fractions of the system total:

|   |                                  |      |
|---|----------------------------------|------|
| 0 | Coal/gas steam generation output | 0.20 |
| 1 | Combined cycle output (GT+ST)    | 0.20 |
| 2 | Simple cycle GT output           | 0.02 |
| 3 | Hydro generation output          | 0.40 |
| 4 | Nuclear output (post-trip)       | 0.02 |
| 5 | Nonresponsive synchronous        | 0.12 |
| 6 | Wind + solar output              | 0.04 |

The inertia constant used in the microcosm simulation is based on the generator dispatch, MVA, and status data in the base case load flow used for the full scale simulation. The system inertia constant estimated on this basis is 3.8 seconds.

The data file specifying the setup of the microcosm simulation is shown in Table 4. The summary of the microcosm simulation is shown in Table 5.

**Table 4. Fleet makeup for microcosm simulation: WECC**

```

ChaPrefix      wecc-
I Type         FMW   Rf   Df
---- Fleet makeup
0 Steam        20000 0.92 0.48
1 CCGT-G       20000 0.92 0.48
2 Hydro        40000 1.00 .65
3 SCGT         2000  0.98 .48
4 Nuclear      2000  .00 .00
5 Nonresp     12000  .00 .00
6 Renewable    4000  .00 .00
---- General settings
deltap        2760
H              3.8
kimw          0.05
lpd           2.
droop         0.04
gbasef        1.78
tbasef        1.20
---- Individual parameter settings
0 end

```

**Table 5. Summary and result of microcosm simulation: WECC**

| Type      | I | Ff   | Rf   | Df   | Qf   | Rmw    | Dmw    | Qmw    |
|-----------|---|------|------|------|------|--------|--------|--------|
| Steam     | 0 | 0.20 | 0.92 | 0.48 | 0.52 | 0.1840 | 0.0883 | 0.0957 |
| CCGT-G    | 1 | 0.20 | 0.92 | 0.48 | 0.52 | 0.1840 | 0.0883 | 0.0957 |
| Hydro     | 2 | 0.40 | 1.00 | 0.65 | 0.35 | 0.4000 | 0.2600 | 0.1400 |
| SCGT      | 3 | 0.02 | 0.98 | 0.48 | 0.52 | 0.0196 | 0.0094 | 0.0102 |
| Nuclear   | 4 | 0.02 | 0.00 | 0.00 | 1.00 | 0.0000 | 0.0000 | 0.0000 |
| Nonresp   | 5 | 0.12 | 0.00 | 0.00 | 1.00 | 0.0000 | 0.0000 | 0.0000 |
| Renewable | 6 | 0.04 | 0.00 | 0.00 | 1.00 | 0.0000 | 0.0000 | 0.0000 |

```

Total generation           = : 10000
Rotating synchronous generation = : 9600
Electronic generation      = : 400
System regulating fraction Rfrac = : 0.788
Sustaining frac (of Rfrac) Dfrac = : 0.566
Non-responsive fraction    Nfrac = : 0.172
Electronic fraction        Efrac = : 0.040

Responsive/sustaining MW    = : 4460.5
Responsive/nonsustaining MW = : 3415.5
Responsive - total MW      = : 7876.0
Non-responsive - total MW  = : 1724.0
Renewable - total MW       = : 400.0
Minimum frequency (Hz)     = : 59.730

Gen loss fraction          = : 0.0276
System inertia constant   = : 3.8000
Load control gain         = : 0.0500
Load freq exponent        = : 2.0000
Governing droop           = : 0.0400
Gen MVA factor            = : 1.7800
Turbine MW factor         = : 1.2000

```

Figure 8 shows the microcosm simulation of frequency for three variations on the fleet makeup given in Table 4 as follows:

- Red: Decrease Steam fraction of fleet by 0.05 pu/increase non-responsive fraction
- Green: Fleet fractions as given in Table 4
- Blue: Increase Steam fraction of fleet by 0.05 pu/decrease non-responsive fraction

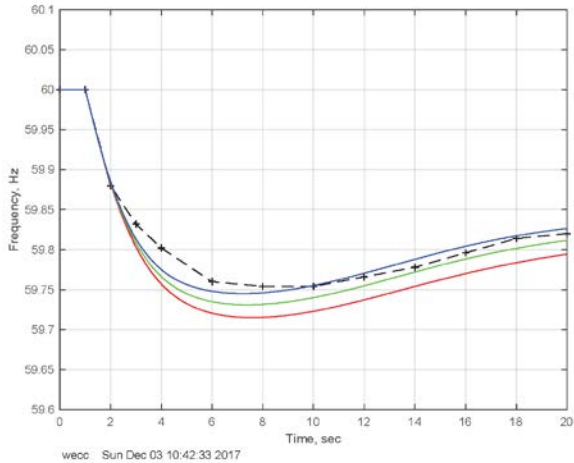

**Figure 8. WECC simulation case 1: Microcosm**

Red - 11 percent steam  
 Green - 16 percent steam  
 Blue - 21 percent steam  
 Black - Full-scale simulation

Figure 9 illustrates the sensitivity of the frequency dip to variations of fleet makeup (Figure 9a) and fleet inertia constant (Figure 9b). For Figure 9a, the fraction of WECC generation in steam plants is varied  $\pm 0.05$  per unit and, for Figure 9b the overall inertia constant of the WECC rotating fleet is varied  $\pm 1.0$  second. (Note that Figure 9a is the same as Figure 8.)

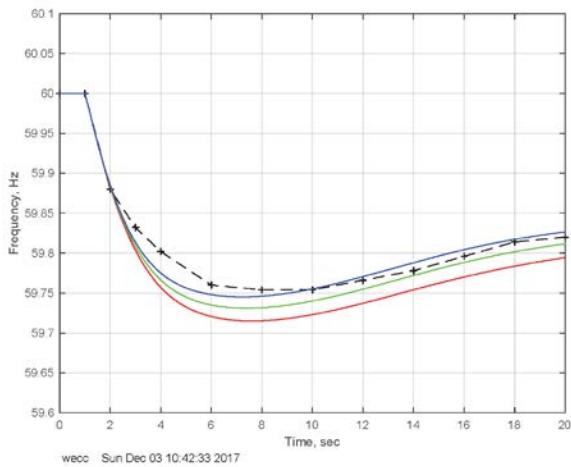

(a) Variation of fleet fraction in steam plants

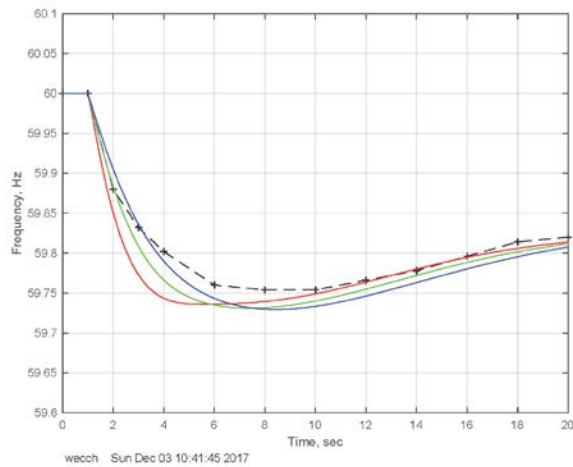

(b) Variation of overall inertia constant

**Figure 9. WECC parameter variations**

(a)  $ff[0] \pm 0.05$   
 (b)  $hg \pm 1.0$

### 3.3 Eastern Interconnection

#### 3.3.1 Comparison with PSS/E simulation

Simulations of the EI system in the PSS/E program considered the loss of 4600 MW, spaced over several seconds, resulting from the trip of several units in the 'Rockport' event. The response of frequency as simulated by PSS/E is shown in Figure 10.

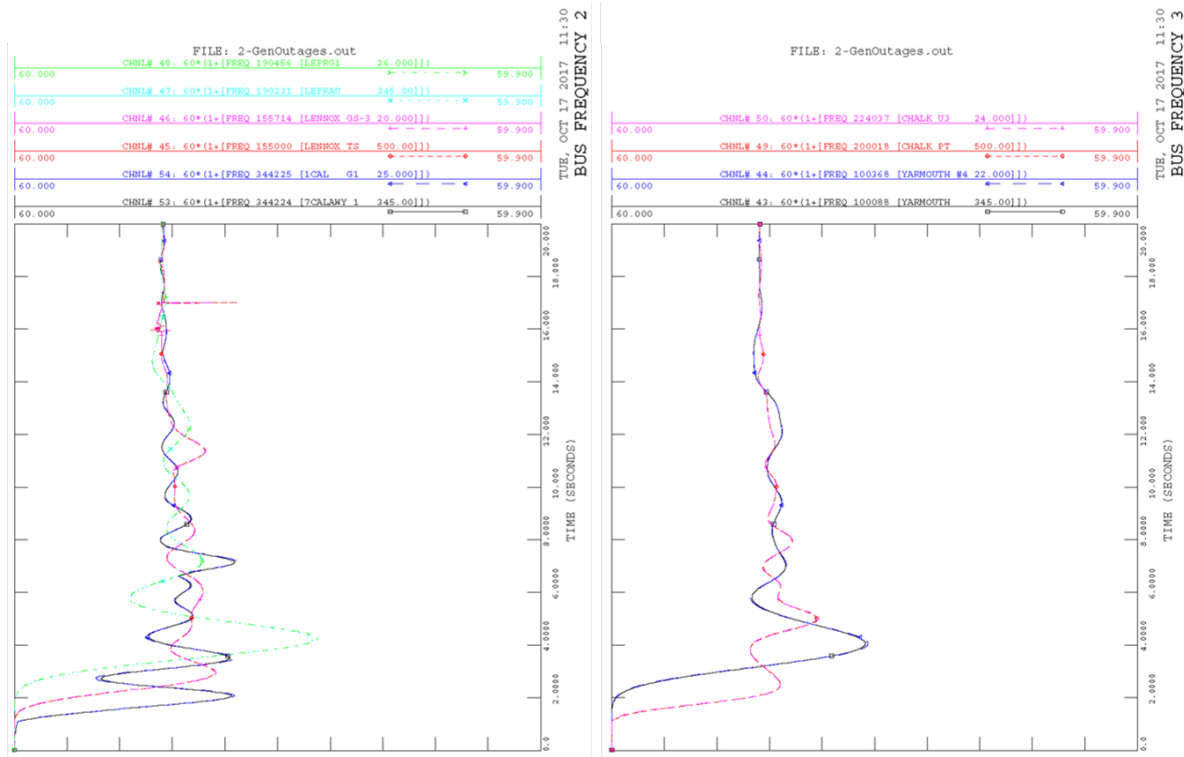

Figure 10. EI simulation case 1: PSS/E

The following have been gleaned from examination of the initial condition load flow solution and the associated dynamics data file:

|   |            |
|---|------------|
| Total generation output                 | 666399 MW  |
| Total connected rotating generation MVA | 926482 MVA |

Based on the above, the fleet makeup has been set up for the microcosm model with the generation grouped as the following fractions of the system total:

|   |                                       |      |
|---|---------------------------------------|------|
| 0 | Coal/gas steam generation output      | 0.60 |
| 1 | Comb. cycle generation (GT+ST) output | 0.10 |
| 2 | Hydro generation output               | 0.03 |
| 3 | Simple cycle GT generation output     | 0.05 |
| 4 | Nuclear generation output(post-trip)  | 0.10 |
| 5 | Nonresponsive synchronous             | 0.11 |
| 6 | Wind + solar generation output        | 0.01 |

The inertia constant used in the microcosm simulation is based on the generator dispatch, MVA, and status data in the base case load flow used for the full scale simulation. The system inertia constant estimated on this basis is 3.95 seconds.

The data file specifying the setup of the microcosm simulation is shown in Table 6. The summary of the microcosm simulation is shown in Table 7.

**Table 6. Fleet makeup for microcosm simulation: EI**

```

ChaPrefix      ei-
I Type         FMW      Rf      Df
-----
0 Steam        0.60    .90    .65
1 CCGT-G       0.10    .90    .65
2 Hydro        0.03    1.00   .90
3 SCGT         0.05    .10    .60
4 Nuclear      0.10    .00    .00
5 Nonresp     0.11    .00    .00
6 Renewable    0.01    .00    .00
-----
deltap        0
H              3.95
kimw          0.005
lpd           1
droop         0.04
gbasef        1.3
tbasef        1.3
-----
0 end

```

**Table 7. Summary and result of microcosm simulation: EI**

```

Type  I   Ff   Rf   Df   Qf   Rmw   Dmw   Qmw
-----
Steam  0  0.60  0.90  0.65  0.35  0.5400  0.3510  0.1890
CCGT-G 1  0.10  0.90  0.65  0.35  0.0900  0.0585  0.0315
Hydro  2  0.03  1.00  0.90  0.10  0.0300  0.0270  0.0030
SCGT   3  0.05  0.10  0.60  0.40  0.0050  0.0030  0.0020
Nuclear 4  0.10  0.00  0.00  1.00  0.0000  0.0000  0.0000
Nonresp 5  0.11  0.00  0.00  1.00  0.0000  0.0000  0.0000
Renewable 6  0.01  0.00  0.00  1.00  0.0000  0.0000  0.0000

Total generation           = : 10000
Rotating synchronous generation = : 9880
Electronic generation     = : 120
System regulating fraction Rfrac = : 0.665
Sustaining frac (of Rfrac) Dfrac = : 0.661
Non-responsive fraction   Nfrac = : 0.323
Electronic fraction       Efrac = : 0.012

Responsive/sustaining MW = : 4395.0
Responsive/nonsustaining MW = : 2255.0
Responsive - total MW = : 6650.0
Non-responsive - total MW = : 3229.9
Renewable - total MW = : 120.1
Minimum frequency (Hz) = : 59.961

Gen loss fraction = : 0.0000
System inertia constant = : 3.9500
Load control gain = : 0.0050
Load freq exponent = : 1.0000
Governing droop = : 0.0400
Gen MVA factor = : 1.3000
Turbine MW factor = : 1.3000

```

Figure 11 shows the microcosm simulation of frequency for three variations on the fleet makeup given in Table 6 as follows:

- Red: Decrease Steam fraction of fleet by 0.05 pu/increase non-responsive fraction
- Green: Fleet fractions as given in Table 6
- Blue: Increase Steam fraction of fleet by 0.05 pu/decrease non-responsive fraction

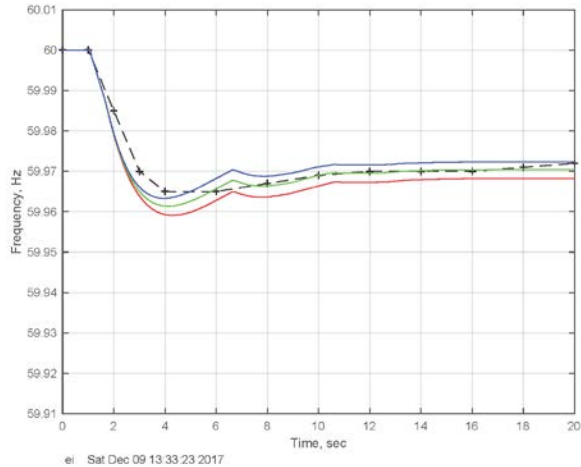

**Figure 11. EI simulation case 1: Microcosm**

Red - 11 percent steam  
 Green - 16 percent steam  
 Blue - 21 percent steam  
 Black - Full-scale simulation

Figure 12 illustrates the sensitivity of the frequency dip to variations of fleet makeup (Figure 12a) and fleet inertia constant (Figure 12b). For Figure 12a, the fraction of EI generation in steam plants is varied  $\pm 0.05$  per unit and, for Figure 12b the overall inertia constant of the EI rotating fleet is varied  $\pm 1.0$  second. (Note that Figure 12a is the same as Figure 11.)

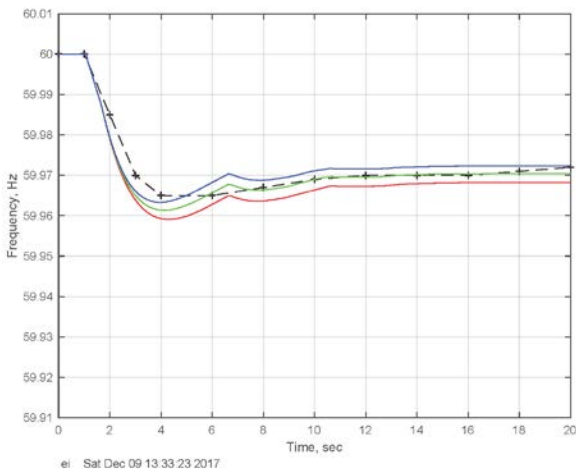

(a) Variation of fleet fraction in steam plants

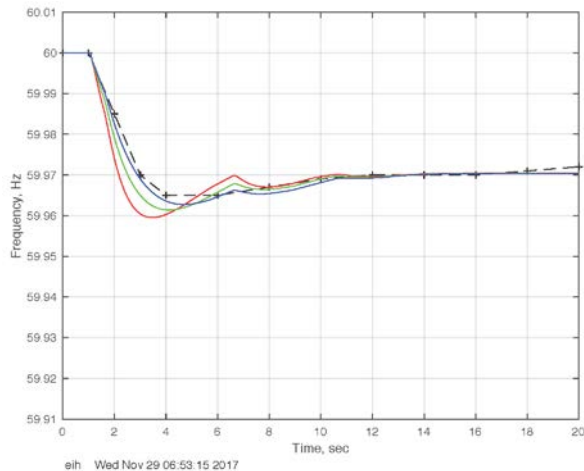

(b) Variation of overall inertia constant

**Figure 12. EI parameter variations**

(a)  $ff[0] \pm 0.05$   
 (b)  $hg \pm 1.0$



### 3.3.2 Comparison with reality

The fleet makeup parameters used in the previous section gave a fair match of the microcosm simulation to a full scale simulation made with PSS/E, but neither the microcosm simulations nor those made with PSS/E are in credible agreement with reality. Figure 13 compares microcosm simulations with a frequency trajectory recorded after the “Rockport event”, and with the PSS/E simulation from the preceding section.

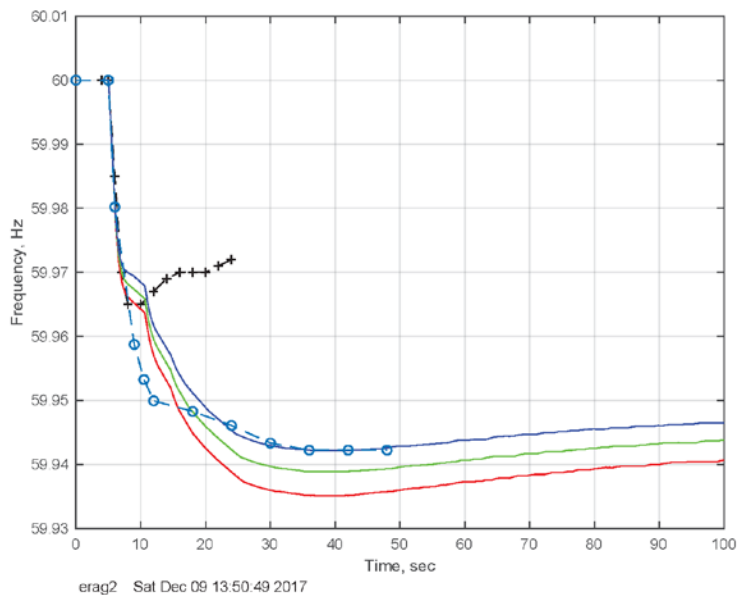

**Figure 13. EI simulation of 'Rockport' event: loss of 4600MW over 9 seconds**

*Red - Microcosm simulation - 11 percent steam  
Green - Microcosm simulation - 16 percent steam  
Blue - Microcosm simulation - 21 percent steam  
+ Simulation made with PSS/E and ERAG data base  
o Recorded frequency*

It is clear that the full scale simulation (black +) does not match the recording of reality (blue o). The three colored traces in Figure 13 are simulations made with the microcosm model using revised values of the fleet description parameters. The following changes were made to the microcosm simulation, relative to the fleet makeup parameters used to match the PSS/E simulation:

- The fractions of the steam and combined cycle generation that contribute frequency response were reduced from 0.9 to 0.7
- The sustaining fractions of the three types of responsive generation were reduced, so that the overall responsive-sustaining fraction of the fleet was reduced from 0.44 to 0.21
- Time constants representing the thermal delays in boiler reheaters and combined-cycle HRSGs were reduced to produce quicker initial response from steam and combined cycle plants

The total amounts of conventional steam, combined cycle, and simple cycle generation were not changed. The revised fleet data file is shown in Table 8.

**Table 8. Adjusted fleet makeup for microcosm simulation to match the 'Rockport' event**

```
ChaPrefix      erag2-
I Type         FMW    Rf    Df
-----
0 Steam        0.60   .70   .35
1 CCGT-G       0.10   .70   .35
2 Hydro        0.03   1.0   .90
3 SCGT         0.05   .70   .35
4 Nuclear      0.10   .00   .00
5 Nonresp      0.11   .00   .00
6 Renewable    0.01   .00   .00
-----
deltap         0
H              3.95
kimw           0.01
lpd            1.0
droop          0.04
gbasef        1.3
tbasef        1.3
-----
10 ggov1 tb 5
11 ggov1 tb 5
13 ccst3 td 20
15 ccst3 td 20
0 end
```

The changed assumptions regarding the fractions of the fleet that produce initial and then sustained response results in microcosm simulation traces that:

- match the initial rate of decrease of frequency
- generally reproduce the 'elbow' where the initial rapid decline of frequency is replaced by slow 'tailing off'
- show a prolonged depression of frequency and match the amount of the depression for a substantial period after the start of the event

## 4. Commentary

- a. The microcosm model depends on parameter values that describe the make-up of the rotating turbine-generator fleet in terms of turbine type and operating mode. The operating modes of primary importance are described by the fraction of each turbine type that is responsive to change of system frequency and the fraction of the responsive generation that sustain the initial response.
- b. It has been possible, to varying degrees among the three interconnections, to glean useful data on the makeups of the fleets by turbine type. However, it has been necessary to make assumptions regarding the fractions of the fleet that are responsive and responsive-sustaining.
- c. The adjustments to the microcosm model that resulted in credible correspondence to recorded reality indicate that the Eastern interconnection data base is strongly optimistic regarding both: the fractions of the thermal turbine-generator fleet that are responsive to frequency, and the fraction of the responsive generation that sustains its initial contribution.

- d. The data bases used in the production grid-scale simulation programs, and the data management facilities provided by those programs, are ill suited to consideration of the frequency control issues faced by the three interconnections. This reflects the way the programs were developed with their primary focus on transmission system issues and related electrical control matters. The dynamic models used to represent power plant components and the provisions for using these models are largely based on the assumption that all plants operate with voltage controls in automatic mode, power system stabilizers in service, and with turbine governors in direct control of real power output.
- e. The dynamic modeling and model management facilities of these programs do not adequately recognize that, while the electrical elements of power plants are in the same automatic operating modes for the great majority of the time, the operating modes of the thermal elements of power plants are many, are different for different types of plant, and are chosen at the discretion of the plant operators.
- f. The dynamic models used to represent power plant operation in the large-scale grid simulation programs are, in many cases, overly detailed with regard to the internal operation of the equipment they represent, and naive with regard to the modes of operation that can be in effect.

## 5. References

Undrill, J.M. (2018a). *Microcosm Model for Simulation of Power System Frequency Dip Transients: Program Manual*. Lawrence Berkeley Laboratory. February.

Undrill, J.M. (2018b). *Primary Frequency Response and Control of Power System Frequency*. Lawrence Berkeley Laboratory. February.