

Lawrence Berkeley National Laboratory

Recent Work

Title

DELAYED PROTON EMISSION OF N=81 ODD-ODD PRECURSORS: ^{148}Ho , ^{150}Tm AND ^{152}Lu

Permalink

<https://escholarship.org/uc/item/4hj7789x>

Author

Nitschke, J.M.

Publication Date

1987-06-01



Lawrence Berkeley Laboratory

UNIVERSITY OF CALIFORNIA

JUN 1987

Submitted to Physical Review C

DELAYED PROTON EMISSION OF N=81 ODD-ODD PRECURSORS: ¹⁴⁸Ho, ¹⁵⁰Tm AND ¹⁵²Lu

J.M. Nitschke, P.A. Wilmarth, J. Gilat,
K.S. Toth, and F.T. Avignone III

June 1987

TWO-WEEK LOAN COPY
*This is a Library Circulating Copy
which may be borrowed for two weeks.*

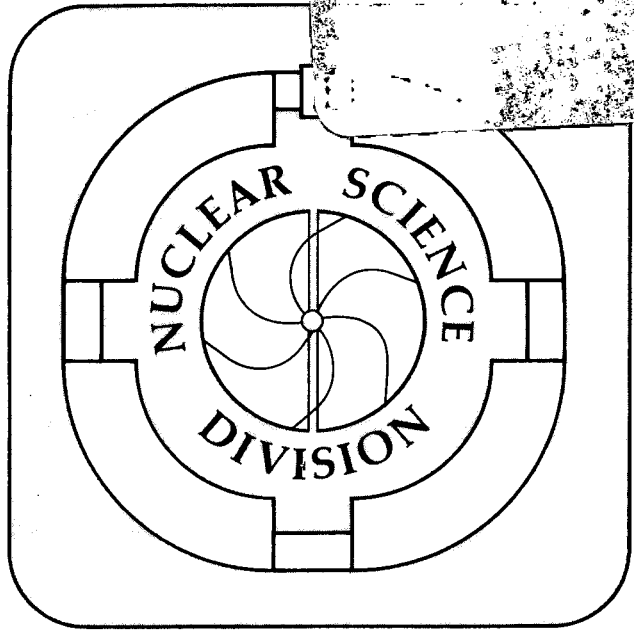

LBL-23408
c.2

DISCLAIMER

This document was prepared as an account of work sponsored by the United States Government. While this document is believed to contain correct information, neither the United States Government nor any agency thereof, nor the Regents of the University of California, nor any of their employees, makes any warranty, express or implied, or assumes any legal responsibility for the accuracy, completeness, or usefulness of any information, apparatus, product, or process disclosed, or represents that its use would not infringe privately owned rights. Reference herein to any specific commercial product, process, or service by its trade name, trademark, manufacturer, or otherwise, does not necessarily constitute or imply its endorsement, recommendation, or favoring by the United States Government or any agency thereof, or the Regents of the University of California. The views and opinions of authors expressed herein do not necessarily state or reflect those of the United States Government or any agency thereof or the Regents of the University of California.

Delayed Proton Emission of N=81 Odd-Odd Precursors:
 ^{148}Ho , ^{150}Tm and ^{152}Lu

J.M. Nitschke, P.A. Wilmarth, J. Gilat,*
K.S. Toth,¹ and F.T. Avignone, III²

Nuclear Science Division
Lawrence Berkeley Laboratory
University of California
Berkeley, California 94720

June 1987

¹ Oak Ridge National Laboratory, Oak Ridge, TN 37831

² University of South Carolina, Columbia, SC 29208

This work was supported by the Director, Office of Energy Research, Division of Nuclear Physics of the Office of High Energy and Nuclear Physics of the U.S. Department of Energy under Contract DE-AC03-76SF00098, and under contract No. DE-AC05-84OR21400 at Oak Ridge National Laboratory, operated by Martin Marietta Energy System, Inc. for the U.S. Department of Energy.

Delayed proton emission of $N=81$ odd-odd precursors: ^{148}Ho , ^{150}Tm , and ^{152}Lu

J. M. Nitschke, P. A. Wilmarth, J. Gilat*
Lawrence Berkeley Laboratory, Berkeley, CA 94720

K.S. Toth
Oak Ridge National Laboratory, Oak Ridge, TN 37831

F. T. Avignone, III
University of South Carolina, Columbus, SC 29208

ABSTRACT

Beta-delayed proton decay was observed in ^{148}Ho , ^{150}Tm , and ^{152}Lu for the first time. Contrary to neighboring even-Z $N=81$ isotones the proton spectra appear structureless and statistical in nature. The proton branching ratios for the three isotopes, based on the intensity of γ -ray transitions in the intermediate nuclei, are: $(8\pm 1)\times 10^{-4}$, $(1.4\pm 0.1)\times 10^{-2}$, and $(1.5\pm 0.7)\times 10^{-1}$, respectively. The onset of proton emission in all three cases occurs at a proton to γ width ratio of about 10^{-4} . Protons were found to be in coincidence with x rays, γ rays, and positrons. Coincident K x rays served to identify the Z of the precursor, while the γ rays gave quantitative information about proton decay to excited states in the daughter nuclei. By comparing the γ intensities with statistical model calculations it was concluded that ^{148}Ho and ^{150}Tm both have isomers with probable spin values of 1^+ and 6^- . Statistical model calculations with "standard" prescriptions for level densities and γ widths reproduced the ^{148}Ho but not the ^{150}Tm and ^{152}Lu branching ratios. For the latter two isotopes, a reduction of the level density parameter to 70% of the "back shifted" Fermi level density was necessary to achieve agreement. To reproduce the shape of the proton spectrum it was necessary to assume Gaussian shaped GT β strength functions centered near 8 MeV excitation energy. In the course of these experiments β -delayed proton emission in ^{148}Er was also identified.

I. INTRODUCTION

Beta-delayed proton emission is a phenomenon characteristic of nuclei near the proton drip line. In the region of $A < 70$ delayed proton spectra are composed of discrete transitions from levels in the intermediate nucleus to levels in the final nucleus, usually dominated by transitions to the isobaric analog state. Levels in the intermediate nucleus typically have spacings larger than the detector resolution for protons due to the relatively low level density in light nuclei. Thus the energies and intensities of the proton lines yield a wealth of information on β decay to levels at high excitation energies.^{1, 2} In contrast, nuclei in the heavier mass regions, such as the rare earth elements, have level densities -- at excitation energies that are sufficiently high for proton decay -- in excess of 10^3 MeV^{-1} . Since the resolution of solid state detectors commonly used for charged particle spectroscopy is rarely better than 10 keV, the proton spectra appear smooth and unresolved. The high level density justifies the treatment of the proton vs. γ -ray emission process in the framework of a statistical model.³ Some proton emitters near the $Z=50$ closed shell show a pronounced structure in their spectra which has been interpreted as Porter-Thomas fluctuations⁴ of the product distribution of the reduced β -transition probability and the particle decay width to the final state. Subsequently, well-defined proton structures were also observed in the precursor ^{147}Dy ^{5, 6}, whose β -decay daughter, ^{147}Tb , is just one proton removed from the doubly magic nucleus ^{146}Gd . This was at first attributed to the reduced level density associated with both the $N=82$ shell and $Z=64$ subshell closures, but it was later shown that the relevant shell is $N=82$ since the sharp structure was also observed in ^{149}Er ^{7, 8, 9} and ^{151}Yb ¹⁰, where the daughter nuclei, ^{149}Ho and ^{151}Tm , are three and five protons removed from $Z=64$, respectively.

The aim of the present investigation was to study $N=81$ isotones with odd- Z numbers to determine whether a qualitative change in the spectra compared to even- Z , $N=81$ isotones would occur. Such a change is expected for the following reasons: (1) in an odd-odd precursor such as $^{150}_{69}\text{Tm}$, an unpaired proton decays into a neutron, leaving the p-emitting nucleus in a state of relatively high excitation energy reflected by a Gamow-Teller (GT) resonance at about 7 MeV [see

Fig. 1(a)], while in an even-odd precursor such as $^{151}_{70}\text{Yb}$, a proton pair has to be broken, lowering the GT resonance in the β -strength function, S_β , by about twice the pairing gap energy to about 5 MeV [Fig. 1(b)]; and (2) β^+ -decaying odd-odd precursors populate even-even emitters with large proton binding energies, S_p , (~ 3 MeV in $^{150}_{68}\text{Er}$), while even-odd precursors populate odd-even emitters with small proton binding energies (~ 0.4 MeV in $^{151}_{69}\text{Tm}$). The combined effect is a 2.5 to 3.5 MeV shift in the mean effective excitation energy from which protons are emitted, which corresponds to a change in level density by about two orders of magnitude.

Another qualitative difference in the proton spectra between odd-odd and even-odd $N=81$ precursors is related to the fact that both have high-spin isomers with spin/parity J^π equal to $\sim 6^-$ (uncertain to ± 1 unit of angular momentum) and $11/2^-$, respectively. In the odd-odd case the final nucleus (odd-even) has two nearly degenerate ground states with $J^\pi=1/2^+$ and $11/2^-$, creating two nearly parallel paths for β -delayed high- and low-spin proton decay [see Fig. 1(a)]. For example, one can write symbolically for the high-spin decay of ^{150}Tm :

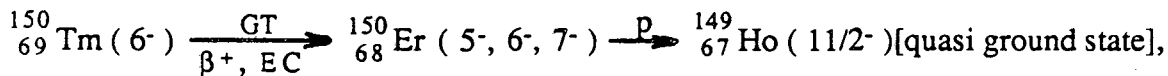

and for the low-spin decay of ^{150}Tm :

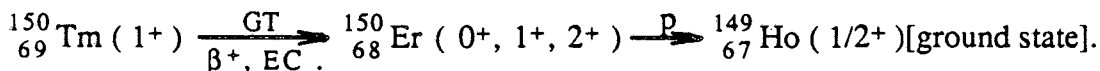

Since the energetics for the two paths are the same within a few hundred keV, the high- and low-spin branches are not easily distinguished experimentally. In contrast, the even-even, $N=82$ final nucleus for an even-odd, $N=81$ precursor [see Fig. 1(b)] has a 0^+ ground state, and higher spin states at 1.5 to 3.0 MeV excitation. This leads to different energetics for the low- and high-spin decay branches [see Fig. 1(b)]. For example, in the case of ^{151}Yb the high-spin decay can be written as:

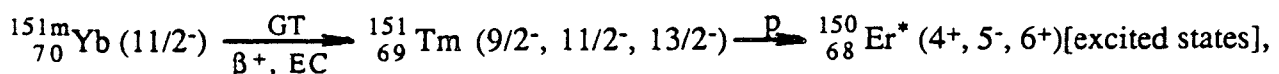

and the low-spin decay as:

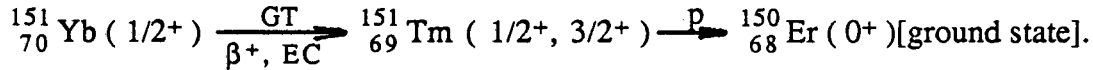

Since the excitation energies in ${}^{151}\text{Tm}$ are different, the two branches can be distinguished experimentally by the different β^+/EC ratios in the decay feedings. We showed in Ref. 10 that the low-spin branch is associated with proton decay from low level density and low excitation energy states in the intermediate nucleus, giving rise to the structured proton spectrum typical for the even-odd, $N=81$ precursors ${}^{147}\text{Dy}$, ${}^{149}\text{Er}$, and ${}^{151}\text{Yb}$. In the same paper it was shown that the high-spin branch gave rise to a statistical spectrum originating from high excitation energies and high level densities in the intermediate nucleus. This high-spin branch in even-odd, $N=81$ precursors is therefore similar to the combined high- and low-spin delayed proton decay branches in odd-odd, $N=81$ precursors. We will show this to be true for the new isotope ${}^{152}\text{Lu}$, and for the delayed-proton branches in ${}^{150}\text{Tm}$ and ${}^{148}\text{Ho}$ observed here for the first time.

Several authors in the past have estimated the threshold for proton emission.^{1, 11} Since we have produced a series of six $N=81$ isotones from ${}^{147}\text{Dy}$ to ${}^{152}\text{Lu}$, we attempted to find a criterion that would give a consistent description of the onset of proton emission. An obvious choice for such a criterion is the ratio of the proton to γ decay widths Γ_p/Γ_γ , since these two processes are in competition with each other. This ratio is approximately equal to $\Gamma_p/(\Gamma_\gamma + \Gamma_p)$ because $\Gamma_p \ll \Gamma_\gamma$ at the onset of proton emission. The proton width is related to the transmission coefficients $T_{e,j}$ and the level density ρ through the well known relationship

$$\Gamma_p(E) = [2\pi\rho(E)]^{-1} \sum_j T_{e,j}(E),$$

where the sum is taken over all initial states in the intermediate nucleus and all final states in the daughter nucleus. Transmission coefficients were calculated with several sets of optical model parameters. Values of Γ_p/Γ_γ quoted in this paper are based on parameters given by Becchetti and Greenlees,¹² while the level densities ρ_j were calculated according to Dilg et al.¹³ Average

radiation widths $\langle \Gamma_\gamma \rangle$ of states with spin J at excitation energy E_x were calculated according to the following formula suggested by Hardy:¹⁴

$$\langle \Gamma_\gamma(E_x) \rangle = \int_0^{E_{\max}} E_\gamma^3 f_{E1}(E_\gamma) \sum_{I=J-1}^{I=J+1} \frac{\rho_I(E_x - E_\gamma)}{\rho_J(E_x)} dE_\gamma,$$

where ρ_J is the density of spin J states, f_{E1} is the strength function for $E1$ γ -decay; $f_{E1}(E_\gamma) = 8.7 \times 10^{-8} \sigma(E_\gamma) / E_\gamma$, and $\sigma(E_\gamma)$ is the photoabsorption cross section in mb.

It was found empirically that the onset of proton emission is observed at a value of $\Gamma_p/\Gamma_\gamma \approx 10^{-4}$. The energy corresponding to this value is indicated in the proton spectra by double arrows. An equally good criterion for the six $N=81$ isotones is $\Gamma_p(E) = 10^{-5}$ eV, marked by single arrows in the proton spectra. Together these criteria give $\Gamma_\gamma = 10^4 \times \Gamma_p = 0.1$ eV, which is equivalent to a lifetime of $\tau_\gamma = 7 \times 10^{-15}$ s. Lifetimes of this order are associated with $E1$ single-particle transitions of about 0.4 MeV or $M1$ transitions of about 1.7 MeV.¹⁵

II. EXPERIMENTAL

To produce the three isotopes ^{152}Lu , ^{150}Tm , and ^{148}Ho , targets of ^{96}Ru and ^{94}Mo were bombarded with beams of ^{58}Ni ions from the Lawrence Berkeley SuperHILAC. Details of the compound nucleus reaction channels, target thickness, target material enrichment, laboratory projectile energy in the midplane of the target, and calculated cross sections¹⁶ are given in Table I. Bombarding energies (column 7) were chosen to optimize the production of the desired isotope (column 1) via the reaction channel given in column 4. Heavy ion beam currents were typically in the range of $(0.5 - 1.0) \times 10^{12}$ particles s^{-1} , limited by the mechanical stability of the gas-cooled ^{96}Ru targets,^{17, 18} or the uncooled ^{94}Mo targets. The evaporation residue recoils were stopped in a tantalum catcher operated close to its melting point (~ 3000 C). The Ta catcher was located inside a surface ionization source. After diffusing out of the catcher and being ionized, the product ions were accelerated to an energy of 50 keV and mass separated in the on-line isotope separator OASIS.¹⁹ The separator was calibrated with stable rare earth isotopes introduced into the ion source as minute quantities of the oxides. For the separation of the radioactive isotopes, small corrections to the mass values of the stable isobars were applied to take into account mass changes within an isobaric chain for nuclei far from stability. A single isobaric chain was selected at the focal plane of the separator and transported ionoptically to a shielded, low background spectroscopy laboratory. Here the 50-keV ions were implanted in a 50- μm Mylar tape and transported within 180 ms to an array of detectors consisting of a Si ΔE -E particle telescope, a hyperpure Ge detector (0.7 keV FWHM resolution at 122 keV), two n-type Ge detectors with relative efficiencies of 24% (1.9 keV FWHM resolution at 1332 keV) and 52% (2.4 keV FWHM resolution at 1332 keV), and a thin plastic $\Delta E\beta$ detector. A scale drawing of the detector arrangement is shown in Fig. 1 of Ref. 20. Coincidences between protons, x rays, γ rays, and positrons were recorded event-by-event on magnetic tape for subsequent off-line analysis. After the arrival of a fresh sample of isotopes at the detector array a quartz controlled clock was started that tagged all events with a relative time signal for half-life information. Appropriate counting time intervals were chosen, taking into account the known or expected half-lives. In the cases of

^{152}Lu , ^{150}Tm , and ^{148}Ho the tape cycles were 4, 8, and 16 seconds, respectively. A new batch of collected isotopes was supplied by the computer controlled tape system at the conclusion of each counting interval. Concurrent with the event-by-event data acquisition, time resolved spectroscopy singles data were taken with the 24% γ -ray detector. Counting intervals for the singles measurements were typically divided into eight equal time bins.

Energy and efficiency calibrations of the Ge detectors were carried out with standard sources; x-ray and γ -ray efficiencies were linked to the efficiency of the particle telescope via the α/γ decay of ^{241}Am . The relative efficiencies of the particle telescope and the 24% γ -detector were also checked during the ^{152}Lu and ^{150}Tm experiments by comparing the α -decay strengths of ^{152}Er and ^{150}Dy relative to photon intensities of known γ -ray transitions in ^{152}Ho and ^{150}Tb . The α branches of ^{152}Er and ^{150}Dy were then deduced to be $86\pm 4\%$ and $39\pm 5\%$, respectively, in agreement with values adopted in Nuclear Data Sheets.^{21,22} These checks are important for judging the reliability of the proton branching ratio measurements. The detection efficiency of the thin (1 mm) ΔE_{β} plastic detector for positrons was calibrated with the lowest-energy proton line in the ^{151}Yb spectrum¹⁰ which is predominately populated by positron decay. A small correction for the EC contribution was applied, and a cross check was carried out by observing the 511 keV annihilation radiation from the positrons in the appropriate detectors.

III. RESULTS

A. Decay of ${}^{148}_{67}\text{Ho}_{81}$ to ${}^{147}_{65}\text{Tb}_{82}$

The high-spin isomer of ${}^{148}\text{Ho}$ was first observed by Toth *et al.*²³ via its decay to the first 3⁻ state of ${}^{148}\text{Dy}$ at 1688 keV. Its half-life was determined to be 9 ± 1 s. Subsequently Nolte *et al.*²⁴ reported the discovery of the low-spin (1⁺) isomer with a half-life of 2.2 ± 1.1 s. Only three γ rays following the decay of ${}^{148}\text{Ho}$ were known at the time, with most of the β decay of the low-spin isomer proceeding directly to the ${}^{148}\text{Dy}$ ground state. In the meantime, a more detailed study²⁵ of the ${}^{148}\text{Ho}$ β decay has been carried out, including the observation of at least 39 transitions.

With the isotope separator calibrated at $A=148$ using the stable isotope ${}^{148}\text{Nd}$, the ΔE - E particle telescope registered the proton spectrum of Fig. 2. Figure 3(a) shows the decay of these protons from which a single component half-life of 8.2 ± 0.6 s was derived. Only $3.4\pm 0.8\%$ of all protons were in coincidence with positrons; the remainder followed electron capture, which gave rise to strong K x-ray peaks in the proton coincident x-ray spectrum shown in Fig. 4(a). The identification of the observed K x rays and the mass determination from the separator unambiguously established the precursor as ${}^{148}\text{Ho}$. In addition to the Dy x-ray lines, two peaks in Fig. 4(a) were identified as Ho $K_{\alpha 1}$ and Ho $K_{\beta 2}$ x rays, indicating that some of the delayed protons were due to a previously unknown β -delayed proton branch in ${}^{148}\text{Er}$. This was confirmed by the presence of a 72-keV γ ray [Figs. 4(a) and 4(b)] which belongs to the known transition between the first excited 3/2⁺ state and the 1/2⁺ ground state of ${}^{147}\text{Dy}$.²⁶ The observation of ${}^{148}\text{Er}$ in this experiment is consistent with a calculated¹⁶ cross section of 9 mb compared to that of 80 mb for ${}^{148}\text{Ho}$, and with the expected similar ionization efficiencies based on the first ionization potentials. The half-life of the proton activity, 8.2 ± 0.6 s, is noticeably shorter than the value of 9.7 ± 0.3 s measured²⁵ for the high-spin isomer of ${}^{148}\text{Ho}$. This indicates: (1) that the high-spin ${}^{148}\text{Ho}$ isomer is the principal contributor to the β -delayed proton spectrum, and (2) that there may be significant admixtures from ${}^{148}\text{Ho}$ low-spin, 2.2 ± 1.1 s,²⁴ and ${}^{148}\text{Er}$, 4.4 ± 0.4 s,²⁵ decays.

The similar magnitudes of the half-lives and limited counting statistics did not allow a reliable decomposition of the proton decay curve into three components. Under the assumption that the ^{148}Ho decay is dominated by the high-spin isomer (see below), a two component decay analysis with fixed half-lives (4.4 s for ^{148}Er and 9.7 s for ^{148}Ho) was carried out. The result, which gave a slightly improved fit compared to the single component analysis and is shown as the curve through the data points [Fig. 3(a)], suggested a $17\pm 6\%$ admixture of ^{148}Er . This was confirmed by a careful analysis of the x-ray intensities [Fig. 4(a)] which yielded an ^{148}Er admixture of $22\pm 5\%$. These calculations were carried out under the assumption that the EC/β^+ ratios integrated over the proton spectrum were the same for ^{148}Ho and ^{148}Er . The measured energies of the proton coincident K_α x rays were 47.5 and 45.9 keV, in agreement with the accepted average K_α energies of 47.3 and 45.7 keV for Ho and Dy, respectively.

As discussed in the Introduction, there exists a "favoured decay path" from the $6^-/1^+$ states of ^{148}Ho to the $h_{11/2}/s_{1/2}$ quasi-degenerate ground state of the daughter nucleus ^{147}Tb .²⁷ Along this path protons can be emitted with low values of angular momentum, hence reducing the centrifugal barrier. For this reason, it is not surprising that only about 10% of the observed protons were in coincidence with γ rays from excited states in ^{147}Tb [Fig. 4(b)]. After taking into account γ -ray efficiencies, losses due to conversion and summing, the proton decay branches, b , feeding levels in ^{147}Tb were: $b(g_{7/2})=7\pm 4\%$, $b(d_{5/2})=1\pm 4\%$, $b(d_{3/2})=3\pm 5\%$, and $b(s_{1/2}, h_{11/2})=89\pm 20\%$. Even though the limited statistical accuracy precluded a detailed analysis, the small branch to the first excited state ($d_{3/2}$) indicates that the contribution of the ^{148}Ho 1^+ precursor state to the proton spectrum is small.

It was possible to obtain an estimate of the proton branching ratio for the ^{148}Ho high-spin isomer by comparing the number of observed protons, N_p , with the number of $3^- \rightarrow 0^+$ plus $2^+ \rightarrow 0^+$ transitions, N_γ , in the intermediate nucleus. This ratio, N_p/N_γ , was measured to be $8\pm 1 \times 10^{-4}$. (The error here and in the N_p/N_γ ratios for ^{150}Tm and ^{152}Lu indicates only the statistical uncertainty.) It should be interpreted as an upper limit to the proton branching ratio due to the following effects: (1) possible contribution to the proton spectrum from the low-spin (1^+)

precursor, most of the β -strength of which proceeds directly to the 0^+ ground state of the intermediate nucleus, (2) unobserved γ rays bypassing the $3^- \rightarrow 0^+$ and $2^+ \rightarrow 0^+$ transitions, and (3) summing of positrons, x rays, annihilation quanta, and other coincident γ rays with the $3^- \rightarrow 0^+$ (1688 keV) and the $2^+ \rightarrow 0^+$ (1678 keV) transitions due to close counting geometries. These effects will tend to increase the average number of γ rays per β decay and lower the experimental proton branching ratio.

It would be of interest to compare the observed final state branching ratios with statistical model calculations in the case of ^{148}Ho and to obtain more quantitative results for the high- to low-spin production ratios and the EC/β^+ to proton branching ratio. In this mass region our efforts were, however, frustrated by the fact that it has not yet been possible to carry out reliable calculations of β -strength functions for both the low and high spin states of the precursor. There are also no measurements available in this region, except for ^{147}mDy .²⁸ This makes it difficult to compare, for instance, experimental proton branching ratios with calculations. Despite the lack of information on β -strength functions an attempt was made to reproduce the observed proton spectrum with a statistical model calculation. Several changes over an earlier model³ were already mentioned in the discussion of the proton emission threshold and the Γ_p/Γ_γ ratio. For the ^{148}Ho high-spin isomer, the β -strength function was represented by a single Gaussian with a centroid E_0 and a width parameter σ , based on the assumption that the shape of the GT resonance might be similar to that observed for ^{147}mDy .²⁸ Values for Q_{EC} of ^{148}Ho and the proton separation energy S_p in ^{148}Dy were obtained from Refs. 29 and 30, respectively. The 6^- state was assumed to lie 0.1 MeV above the 1^+ ground state, and E_0 and σ were varied until the best fit to the shape of the experimentally observed proton spectrum was obtained. The final result of the statistical model calculation, shown in Fig. 2 as a smooth curve, was obtained with the following set of parameters: $E_0=8.4$ MeV, $\sigma=0.825$ MeV, $Q_{\text{EC}}=10.0$ MeV, and $S_p=4.31$ MeV. The calculated proton branching ratio is $P_p=1.1 \times 10^{-3}$ is in agreement with the experimental value, and the relative branches to levels in ^{147}Tb are: $b(g_{7/2})=2.3\%$, $b(d_{5/2})=1.7\%$, $b(d_{3/2})=0.8\%$, and $b(h_{11/2})=94.5\%$. Considering the difficulties inherent in the measurements of absolute proton

branching ratios and the weak excited state feeding a comparison of experiment and calculation confirms our understanding of the $^{148}\text{Ho}(6^-)$ β -delayed proton decay.

Interpretation of the observed ^{148}Er β -delayed proton decay is simplified by the precursor 0^+ ground state and the nonexistence of a long-lived high-spin isomer. A statistical model calculation for ^{148}Er predicts that the first excited $3/2^+$ state of ^{147}Dy at 72 keV should be populated by proton decay with 48% probability, with the remaining 52% going to the $1/2^+$ ground state. The experimental branching ratios deduced from the number of protons in coincidence with the 72-keV γ ray [Fig. 4] and the estimated total number of observed protons, were: $61\pm 24\%$ feeding the $3/2^+$ level and $39\pm 19\%$ feeding the ground state, in agreement with the calculations.

B. Decay of $^{150}_{69}\text{Tm}_{81}$ to $^{149}_{67}\text{Ho}_{82}$

The isotope ^{150}Tm was first identified by Nolte *et al.*³¹ who reported a half-life of 3.5 ± 0.6 s and the observation of four γ rays in its β decay to ^{150}Er . A more extensive study of the ^{150}Tm β decay was published recently³² and a half-life of 2.2 ± 0.2 s for the 6^- state of ^{150}Tm was obtained. There was indirect evidence that a low-spin (1^+) isomer in ^{150}Tm was also present but no isomeric transition was observed and no half-life determined.

The proton energy spectrum and decay curve measured in our experiment for $A=150$ is shown in Fig. 5(a), and the decay curve in Fig. 3(b). A half-life of 2.15 ± 0.10 s was derived which is in agreement with the value of 2.2 ± 0.2 s obtained from γ decay and reported in Ref. 32. Since the observed γ rays³² originated from the high-spin (6^-) isomer this indicates that the proton spectrum is dominated by decay from this state (unless the low-spin state has a similar half-life). Figure 5(b) shows the observed positron coincident proton spectrum. The curve in Fig. 5(b) is the smoothed, unbiased proton spectrum [Fig. 5(a)] multiplied by the ratio of the Fermi functions $f^+/(f^+ + f^{\text{EC}})$. It can be seen that the observed positron coincident spectrum reflects closely the expected spectrum, except perhaps, for some excess strength at about 3 MeV proton decay energy. The x-ray spectrum coincident with EC-delayed protons is shown in Fig. 6; the observed x-ray energies of 48.7, 55.6, and 57.3 keV are in excellent agreement with accepted K_{α} , $K_{\beta 1}$, and $K_{\beta 2}$ x-ray energies for Er of 48.8, 55.7, and 57.1 keV, respectively. This, in conjunction with the mass selection through the isotope separator, uniquely identifies the precursor as ^{150}Tm . Contrary to the $A=148$ experiment, there was no indication of a second group of x rays associated with another proton emitter. A possible candidate would have been ^{150}Yb , but its calculated¹⁶ cross section is only 0.7 mb compared to 22 mb for ^{150}Tm . Another discriminating factor was the expected half-life of 0.8 s for ^{150}Yb .³³ An isotope of such short half-life would have been strongly suppressed by the 8-s tape cycle employed in this experiment. A third factor hindering the observation of ^{150}Yb is the higher first ionization energy of 6.25 eV for Yb compared to 6.18 eV

for Tm. From the coincident x-ray spectrum (Fig. 6) an upper limit of 5% of the Tm activity was set for the observation of a Yb proton precursor.

As was already discussed for the decay of ^{148}Ho , an upper limit to the proton branching ratio can be obtained for a high-spin odd-odd precursor because almost all of its β -delayed γ decay proceeds via allowed GT transitions to high-spin states which ultimately concentrate their strength in one or two prominent transitions to the 0^+ ground state of the even-even intermediate nucleus. In ^{150}Er these transitions are the $3^- \rightarrow 0^+$ 1786.6-keV and the $2^+ \rightarrow 0^+$ 1579.0-keV γ rays. The ratio of the observed protons to the number of 1787- and 1579-keV γ rays is $(1.4 \pm 0.1) \times 10^{-2}$.

It can be seen in Fig. 6 that protons are observed in coincidence with several γ rays that can be identified as transitions in the daughter nucleus ^{149}Ho . Members of the high-spin band³⁴ (not shown in Fig. 6) terminating in the $11/2^-$ state and members of the low-spin band^{35, 36} decaying to the $1/2^+$ state were observed. As in the case of ^{148}Ho the favoured decay path from the $6^-/1^+$ states of the precursor leads to the $11/2^-/1/2^+$ ground states of the daughter nucleus. This results in small branches to excited states in ^{149}Ho and consequently in a low statistical accuracy for the observation of γ transitions from these states. The third column of Table II summarizes the observed relative proton branches to levels in ^{149}Ho .

Statistical model calculations were carried out to compare the experimental final state feedings with different assumptions about the precursor spin and parity. Again, because of the lack of theoretical or experimental information, the parameters of a single Gaussian distribution of the β strength were varied until a fit to the experimental proton spectrum was obtained. This is shown as the smooth curve in Fig. 5(a). The parameters E_0 and σ of the β strength distribution, and the Q_{EC} and S_p values used in the calculation were: $E_0=7.8$ MeV, $\sigma=1.45$ MeV, $Q_{\text{EC}}=11.7$ MeV, and $S_p=3.0$ MeV. The value for S_p was obtained from Ref. 29. The Q_{EC} value calculated from the same table was 11.4 MeV; we found it, however, necessary to increase this value to 11.7 MeV to correctly match the upper flank of the proton spectrum [Fig. 5(a)].

The branching ratio of 1.4×10^{-2} is unexpectedly large and even though it was pointed out in Section IIIA that this ratio is an upper limit we have nonetheless studied the effects of varying

different parameters of the statistical model to reproduce this enhanced proton emission. Several of the parameters of the statistical model are constrained by systematics (Q_{EC} and S_p), others by the final state branching ratios (J^π), the shape of the proton spectrum (S_β), or the positron coincident to total proton ratio (Q_{EC} and S_p). The strongest influence on the proton branching ratio (without altering the agreement with other experimental results) is exhibited by the level density parameter, a , and the gamma width. A reduction in the level density parameter increases the proton width in inverse proportion while a lowering of the γ width favors proton decay by reducing γ competition. We have found that in the case of ^{150}Tm reducing a to 70%, or Γ_γ by a factor of 10 achieves the same effect: it raises the proton branching ratio by an order of magnitude. To distinguish between the two possible alternatives it is worth remembering that a reduced level density has already been postulated as the underlying cause for the structure in the proton spectra of the even-odd $N=81$ precursors.^{8, 10} It therefore seems conceivable that this effect could also make itself felt in the odd-odd $N=81$ precursors. By reducing a to 70% of the value of the "back shifted" Fermi level density,¹³ proton branching ratios of 1.2% and 1.9% were calculated for the 6^- and 1^+ states of ^{150}Tm , respectively. More detailed results of the calculations for these two states are given in Table II. Comparing the experimental final state proton branching ratios with the results for $^{150}\text{Tm}(6^-)$ it is evident that this calculation does not reproduce the feeding to the excited states in ^{149}Ho correctly; the same is true for the calculation starting with $^{150}\text{Tm}(1^+)$. A much better agreement with the experiment is, however, achieved with a 20% mixture of the 1^+ decay with 80% of the 6^- decay as shown in the last column of Table II. Under these conditions, the weighted proton branching ratio is 1.3% compared to the upper limit of 1.4% from the experiment. From the $6^-/1^+$ mixing ratio and the calculated $6^-/1^+$ proton branches, the production ratio, R , for the high-spin to low-spin precursors was estimated to be: $R \approx (80/20) \times (1.9/1.2) \approx 6.3$. This value is consistent with the high-spin selectivity of heavy ion reactions and the non-observation of an isomeric transition. It should be mentioned parenthetically that the proton branching ratios to the final states are not very sensitive to small variations in Q_{EC} , S_p , and the beta strength function.

C. Decay of $^{152}_{71}\text{Lu}_{81}$ to $^{151}_{69}\text{Tm}_{82}$

We previously reported²⁰ the first observation of ^{152}Lu and its decay to levels of ^{152}Yb . The half-life of the new isotope based on the deexcitation of levels in ^{152}Yb was 0.7 ± 0.1 s. From the observation of an allowed transition to a 5^- level it was concluded that the spin/parity of ^{152}Lu is 4^- , 5^- , or 6^- . Due to a low counting rate, no evidence for a low-spin isomer was seen.

The β -delayed proton spectrum measured at $A=152$ is shown in Fig. 7. From the decay curve, Fig. 3(c), a half-life of 0.6 ± 0.1 was extracted which is in agreement with the ^{152}Lu half-life determined from the γ -ray data.²⁰ The small predicted production cross section (0.4 mb)¹⁶ and the short half-life resulted in low counting statistics, and consequently less information could be obtained for ^{152}Lu compared to the other two odd-odd precursors discussed above. Copious amounts of α particles from ^{152}Er were produced via sequential β decay from ^{152}Yb which was synthesized in the reaction $^{96}\text{Ru}(^{58}\text{Ni}, 2p)$. The ratio of α particles to protons was 250:1; during data analysis this strong α background was suppressed by well known ΔE - E particle identification techniques. Only Yb K x rays were observed in coincidence with the protons which uniquely established the Z of the ^{152}Lu precursor. No proton coincident γ rays in the daughter nucleus ^{151}Tm were identified.

Statistical model calculations were again carried out with the reservations expressed for the other two odd-odd precursors, except that in this case the β strength function was represented by four Gaussians. Their relative intensities (A_n), centroids (E_n), and σ -values (σ_n) for $n=1$ through 4 were: $A_1=1.0$, $A_2=0.2$, $A_3=0.2$, $A_4=0.2$; $E_1=5.8$, $E_2=7.0$, $E_3=8.1$, $E_4=9.5$ (MeV); $\sigma_1=0.6$, $\sigma_2=0.7$, $\sigma_3=0.8$, $\sigma_4=0.8$ (MeV). No physical significance for these values is claimed other than to represent the distribution of the beta strength necessary to reproduce the wide asymmetric proton spectrum observed for ^{152}Lu . Values for $Q_{\text{EC}}=12.75$ MeV and $S_p=2.02$ MeV were calculated from Ref. 29 and levels in ^{151}Tm were taken from Ref. 37. If the assumption is made that the proton activity originates from a 6^- state in ^{152}Lu , a proton branching ratio of 1.5% is calculated; for a 1^+ state the ratio is 3.1%. Experimentally, the upper limit for the proton branching ratio was

(15 ± 7)% based on the observed intensity of the 1531-keV $2^+ \rightarrow 0^+$ transition in ^{152}Yb . Even though the ratio of the contributions of the high and low spin states of ^{152}Lu to the proton decay is not known it is evident that the calculated proton branching ratio is substantially smaller.

Calculational variations of the Q_{EC} and S_p within the uncertainties of current mass tables are unable to increase this ratio sufficiently; however, as in the case of ^{150}Tm the discrepancy can be eliminated by either reducing Γ_γ a factor of 10, or by reducing the level density parameter to 70% of the "back shifted" value. In both cases the calculated proton branching ratio increases to 11%.

IV. CONCLUDING REMARKS

For the first time a group of three odd-odd $N=81$ β -delayed proton precursors was studied. The proton spectra are distinctly different from the even-odd $N=81$ precursors in that they resemble more closely the statistical spectra typical for heavy nuclei far from shell closures. This is interpreted as the signature of a decay path that starts with a high-spin precursor and ends in the high-spin ground state of the daughter nucleus, thereby sampling high excitation energies and level densities in the intermediate nucleus. Such conditions justify the treatment of these decays in the framework of a statistical model. One prediction of the calculation is the proton branching ratio. The calculated ratio was found to agree with the experimental value for ^{148}Ho ; discrepancies between the experiment and predictions of an order of magnitude were observed for ^{150}Tm and ^{152}Lu . It was possible to eliminate this discrepancy by reducing the level density parameter in the statistical model, guided by observations in the proton decays of ^{147}Dy , ^{149}Er , and ^{151}Yb . It remains, however, unclear why such a reduction was not necessary for ^{148}Ho .

The observed half-lives for $^{152}\text{Lu}(6^-)$ 0.7 s, $^{150}\text{Tm}(6^-)$ 2.2 s, and $^{148}\text{Ho}(6^-)/^{148}\text{Ho}(1^+)$ 9.7/2.2 s are in good agreement with the predictions of the "Gross Theory of Beta Decay" ³³ of 0.5, 1.2, and 5.7 s, respectively. Half-lives obtained from proton decay agree with those obtained from γ -ray data taken in the same experiments; the half-life of ^{150}Tm disagrees with that available in the literature.²⁴ In the course of these experiments β -delayed proton emission in ^{148}Er was also identified.

ACKNOWLEDGMENTS

The authors wish to thank Y. A. Ellis-Akovali, M. N. Rao, and D. M. Moltz for their participation in the data taking phase of this investigation. The work at Lawrence Berkeley Laboratory was supported by the Director, Office of Energy Research, Division of Nuclear Physics of the Office of High Energy and Nuclear Physics of the U.S. Department of Energy under Contract DE-AC03-76SF00098. Oak Ridge National Laboratory is operated by Martin Marietta Energy Systems, Inc. for the U. S. Department of Energy under Contract No. DE-AC05-84OR21400.

REFERENCES

*On leave from Soreq Nuclear Research Center, Yavne, Israel

- ¹J. C Hardy, "Nuclear Spectroscopy from Delayed Particle Emission", in Nuclear Spectroscopy and Reactions, Part C, J. Cerny ed. (Academic Press, New York and London 1974) p. 417.
- ²J. Cerny and J. C. Hardy, Ann. Rev. Nucl. Sci. 27, 333 (1977).
- ³P. Hornshøj, K. Wilsky, P. G. Hansen, B. Jonson and O. B. Nielsen, Nucl. Phys. A187, 609 (1972).
- ⁴T. Elmroth, E. Hagberg, P. G. Hansen, J. C. Hardy, B. Jonson, H. Ravn and P. Tiedemand-Peterson, Nucl. Phys. A304, 493 (1978).
- ⁵O. Klepper, T. Batsch, S. Hofmann, R. Kirchner, W. Kurcewicz, W. Reisdorf, E. Roeckl, D. Schardt and G. Nyman, Z. Phys. A305, 125 (1982).
- ⁶R. Kirchner, O. Klepper, W. Kurcewicz, P. O. Larsson, E. Roeckl, D. Schardt, G. Nyman and P. Tidemand-Peterson, Proc. Intl. Workshop on Gross Properties of Nuclei and Nuclear Excitations XI, H. Feldmeier ed. (Hirschegg, 1983) p. 60
- ⁷K. S. Toth, D. M. Moltz, E. C. Schloemer, M. D. Cable, F. T. Avignone III and Y. A. Ellis-Akovi, Phys. Rev. C 30, 712 (1984).
- ⁸D. Schardt, P. O. Larsson, R. Kirchner, O. Klepper, V. T. Koslowsky, E. Roeckl, K. Rykaczewski, P. Kleinheinz and K. Zuber, Proceedings of the 7th Intl. Conf. on Atomic Masses and Fundamental Constants, AMCO-7, O. Klepper ed. (Darmstadt, 1984) p. 229.
- ⁹K. S. Toth, D. M. Moltz, E. C. Schloemer, M. D. Cable, F. T. Avignone III and Y. A. Ellis-Akovi, Proceedings of the 7th Intl. Conf. on Atomic Masses and Fundamental Constants, AMCO-7, O. Klepper ed. (Darmstadt, 1984) p. 237.
- ¹⁰K. S. Toth, Y. A. Ellis-Akovi, J. M. Nitschke, P. A. Wilmarth, P. K. Lemmert, D. M. Moltz and F. T. Avignone III, Phys. Lett. B 178, 150 (1986).
- ¹¹V. A. Karnaukhov, Nukleonika 19, 425 (1974).
- ¹²F. D. Becchetti Jr. and G. W. Greenlees, Phys. Rev. 182, 1190 (1969).
- ¹³W. Dilg, W. Schantl and H. Vonach, Nucl. Phys. A217, 269 (1973).
- ¹⁴J. C. Hardy, Phys. Lett. B 109, 242 (1982).
- ¹⁵J. M. Blatt and V. F. Weisskopf, "Theoretical Nuclear Physics" (John Wiley and Sons, New York 1952) p. 627.

- 16W. G. Winn, H. H. Gutbrod and M. Blann, Nucl. Phys. A188, 423 (1972).
- 17J. M. Nitschke, Nucl. Instr. and Meth. 138, 393 (1976).
- 18J. D. Molitoris and J. M. Nitschke, Nucl. Instr. and Meth. 186, 659 (1981).
- 19J. M. Nitschke, Nucl. Instr. and Meth. 206, 341 (1983).
- 20K. S. Toth, D. C. Sousa, J. M. Nitschke and P. A. Wilmarth, Phys. Rev. C 35, 310 (1987).
- 21C. A. Baglin, Nucl. Data Sheets 30, 1 (1980).
- 22E. der Mateosian, Nucl. Data Sheets 48, 345 (1986).
- 23K. S. Toth, C. R. Bingham, D. R. Zolnowski, S. E. Cala, H. K. Carter and D. C. Sousa, Phys. Rev. C 19, 482 (1979).
- 24E. Nolte, S. Z. Gui, G. Colombo, G. Korschinek and K. Eskola, Z. Phys. A306, 223 (1982).
- 25K. S. Toth, D. C. Sousa, J. M. Nitschke and P. A. Wilmarth, to be published.
- 26K. S. Toth, A. E. Rainis, C. R. Bingham, E. Newman, H. K. Carter and W. -D. Schmidt-Ott, Phys. Lett. B 56, 29 (1975).
- 27K. S. Toth, D. M. Moltz, Y. A. Ellis-Akovali, C. R. Bingham, M. D. Cable, R. F. Parry and J. M. Wouters, Phys. Rev. C 25, 667 (1982).
- 28G. D. Alkhasov, A. A. Bykov, V. D. Wittmann, V. E. Starbodubsky, S. Yu. Orlov, V. N. Panteleyev, A. G. Polyakov and V. K. Tarasov, Nucl. Phys. A438, 482 (1985).
- 29S. Liran and N. Zeldes, At. Data and Nucl. Data Tables 17, 431 (1976).
- 30A. H. Wapstra and G. Audi, Nucl. Phys. A432, 55 (1985).
- 31E. Nolte, G. Colombo, S. Z. Gui, G. Korschinek, W. Schollmeier, P. Kubik, S. Gustavsson, R. Geier and H. Morinaga, Z. Phys. A306, 211 (1982).
- 32K. S. Toth, D. C. Sousa, J. M. Nitschke and P. A. Wilmarth, Phys. Rev. C 35, 620 (1987).
- 33K. Takahashi, M. Yamada and T. Kondoh, At. Data and Nucl. Data Tables 12, 101 (1973).
- 34J. Wilson, S. R. Faber, P. J. Daly, I. Ahmad, J. Borggreen, P. Chowdhury, T. L. Khoo, R. D. Lawson, R. K. Smither and J. Blomqvist, Z. Phys. A296, 185 (1980).

³⁵D. Schardt, P. O. Larsson, R. Kirchner, O. Klepper, V. T. Koslowsky, E. Roeckl, K. Rykaczewski, K. Zuber, N. Roy, P. Kleinheinz and J. Blomqvist, Proceedings of the 7th Intl. Conf. on Atomic Masses and Fundamental Constants, AMCO-7, O. Klepper ed. (Darmstadt, 1984) p. 222.

³⁶K. S. Toth, Y. A. Ellis-Akovali, F. T. Avignone III, R. S. Moore, D. M. Moltz, J. M. Nitschke, P. A. Wilmarth, P. K. Lemmertz, D. C. Sousa and A. L. Goodman, Phys. Rev. C 32, 342(1985).

³⁷P. Kleinheinz, B. Rubio, M. Ogawa, M. Piiparinen, A. Plochocki, D. Schardt, R. Barden, O. Klepper, R. Kirchner and E. Roeckl, Z. Phys. A323, 705(1985).

TABLE I. Experimental parameters for the production of the β -delayed proton precursors $^{152}_{71}\text{Lu}$, $^{150}_{69}\text{Tm}$, and $^{148}_{67}\text{Ho}$.

Isotope	Target	Projectile	Reaction Channel	Target Thickness (mg/cm ²)	Target Enrichment (%)	Projectile Lab. Energy Target Center (MeV)	Calculated Cross Section at Projectile Energy (mb)
$^{148}_{67}\text{Ho}$	$^{94}_{42}\text{Mo}$	$^{58}_{28}\text{Ni}$	3pn	2.0	93.9	257	80
$^{150}_{69}\text{Tm}$	$^{96}_{44}\text{Ru}$	$^{58}_{28}\text{Ni}$	3pn	1.6	96.5	267	20
$^{152}_{71}\text{Lu}$	$^{96}_{44}\text{Ru}$	$^{58}_{28}\text{Ni}$	pn	1.5	96.5	244	0.4

TABLE II. Experimental and calculated β -delayed proton branches from $^{150}_{69}\text{Tm}$ to levels in $^{149}_{67}\text{Ho}$. The last column represents a mixture of 80% 6^- decay and 20% 1^+ decay.

Levels in ^{149}Ho		Proton Branching Ratios (%)			
J^π	Energy (keV)	Experiment	Calc. $^{150}\text{Tm}(6^-)$	Calc. $^{150}\text{Tm}(1^+)$	$[0.8(6^-) + 0.2(1^+)]$
$1/2^+$	0	78 ± 4.7	92.3	46.3	83.1
$11/2^-$					
$3/2^+$	171.5	6.5 ± 2.4	1.7	41.2	9.6
$5/2^+$	515.4	4.3 ± 1.9	1.8	11.5	3.7
$7/2^+$	952.1	4.5 ± 1.3	2.2	1.0	2.0
$15/2^+$ ^a	1380 ^b	5.4 ± 2.7	1.4	0.0	1.1
$15/2^-$ ^a	1560 ^b	1.2 ± 1.2	0.6	0.0	0.5

^a Spin and parity assignments of these levels are uncertain; the statistical model calculations are, however, not sensitive to variations of ± 1 unit of angular momentum because of the low branching ratios.

^b Reference 34.

FIGURE CAPTIONS

FIG. 1. Schematic representation of β -delayed proton decay in (a) odd-Z and (b) even-Z $N=81$ precursors (see text).

FIG. 2. Proton spectrum from Ho and Er observed with the ΔE -E particle telescope at mass 148. The proton decay energy Q_p is calculated as the sum of the experimental proton energy and the recoil energy. A single arrow marks the energy at which $\Gamma_p=10^{-5}$ eV, a double arrow indicates where $\Gamma_p/\Gamma_\gamma=10^{-4}$ eV. The smooth curve is the result of a statistical model calculation for the ^{148}Ho high-spin isomer only (see text), normalized to the total number of observed protons.

FIG. 3. (a) Decay of the proton activity at a mass separator setting of $A=148$ during a tape cycle of 16-s duration, (b) the same for $A=150$ and a tape cycle of 8-s duration, and (c) the same for $A=152$ and a tape cycle of 4-s duration.

FIG. 4. (a) Low-energy photons in coincidence with protons, observed at a mass separator setting of $A=148$. Dysprosium and holmium K x rays are identified as well as a γ transition in ^{147}Dy . (b) Gamma rays coincident with protons, observed at the same mass separator setting. Transitions in ^{147}Dy and ^{147}Tb are indicated.

FIG. 5. (a) Proton spectrum observed at mass 150. For an explanation of Q_p and the two arrows see caption of Fig. 2. The smooth curve is the result of a statistical model calculation (see text), normalized to the total number of observed protons. The contributions of the 6^- and 1^+ states of ^{150}Tm are assumed to be 80% and 20%, respectively (see Table II and text). (b) Protons observed in coincidence with positrons. The curve was obtained by smoothing the proton spectrum in part (a) and multiplying it by the ratio of the Fermi functions $f^+/(f^++f^{EC})$.

FIG. 6. Gamma rays in ^{149}Ho , and K x rays measured in coincidence with ^{150}Tm β -delayed protons; additional γ rays were observed at 1381 keV and 1552 keV.

FIG. 7. (a) Proton spectrum observed at mass 152. For an explanation of Q_p and the two arrows see caption of Fig. 2. The smooth curve is the result of a statistical model calculation (see text), normalized to the total number of observed protons.

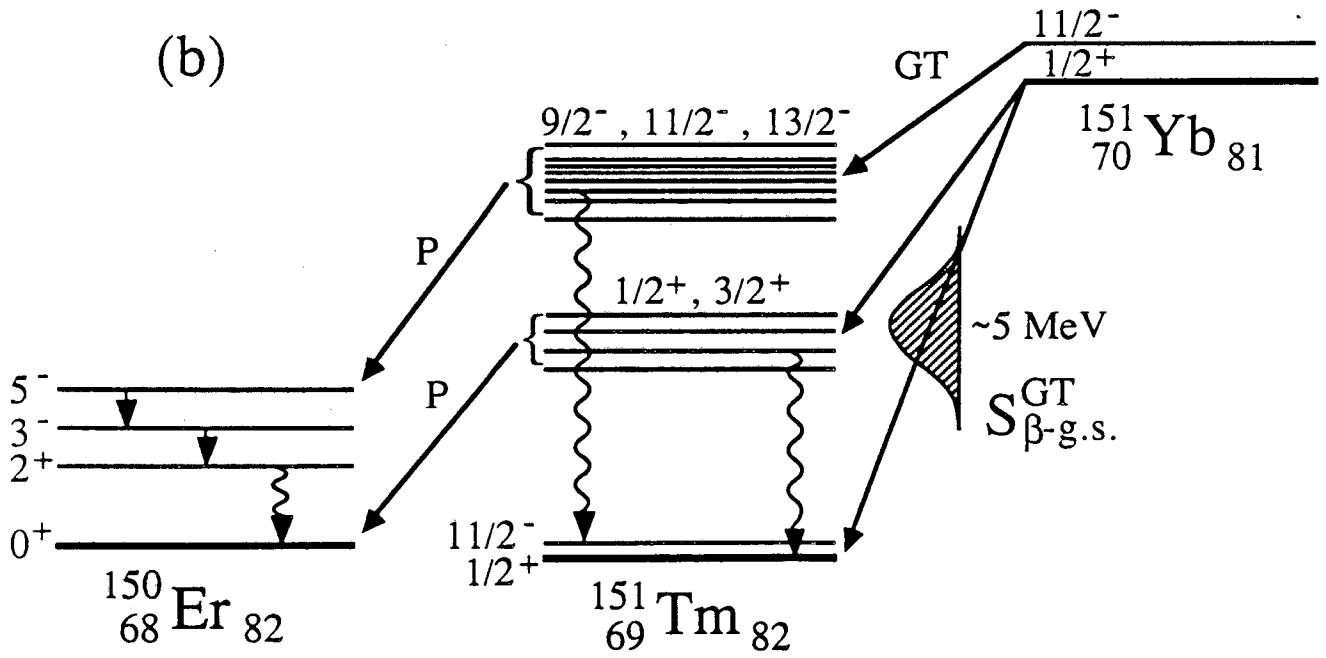
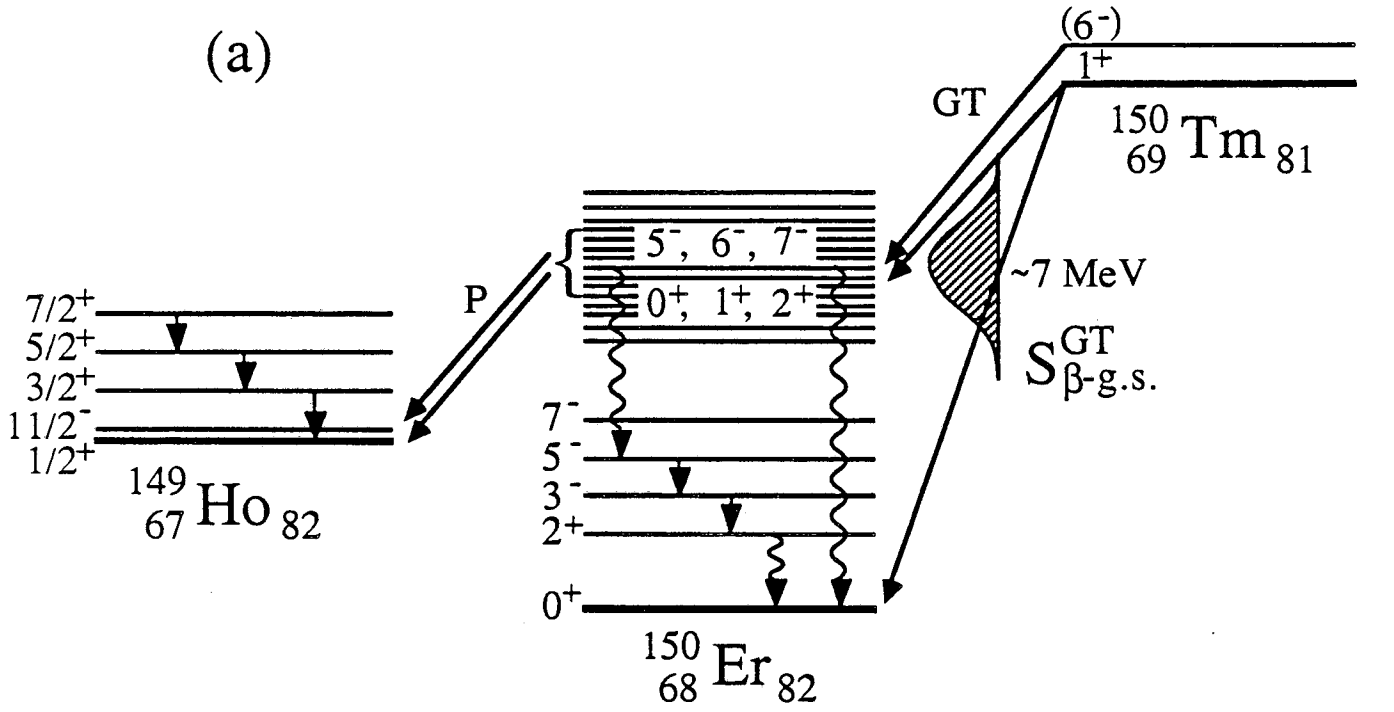
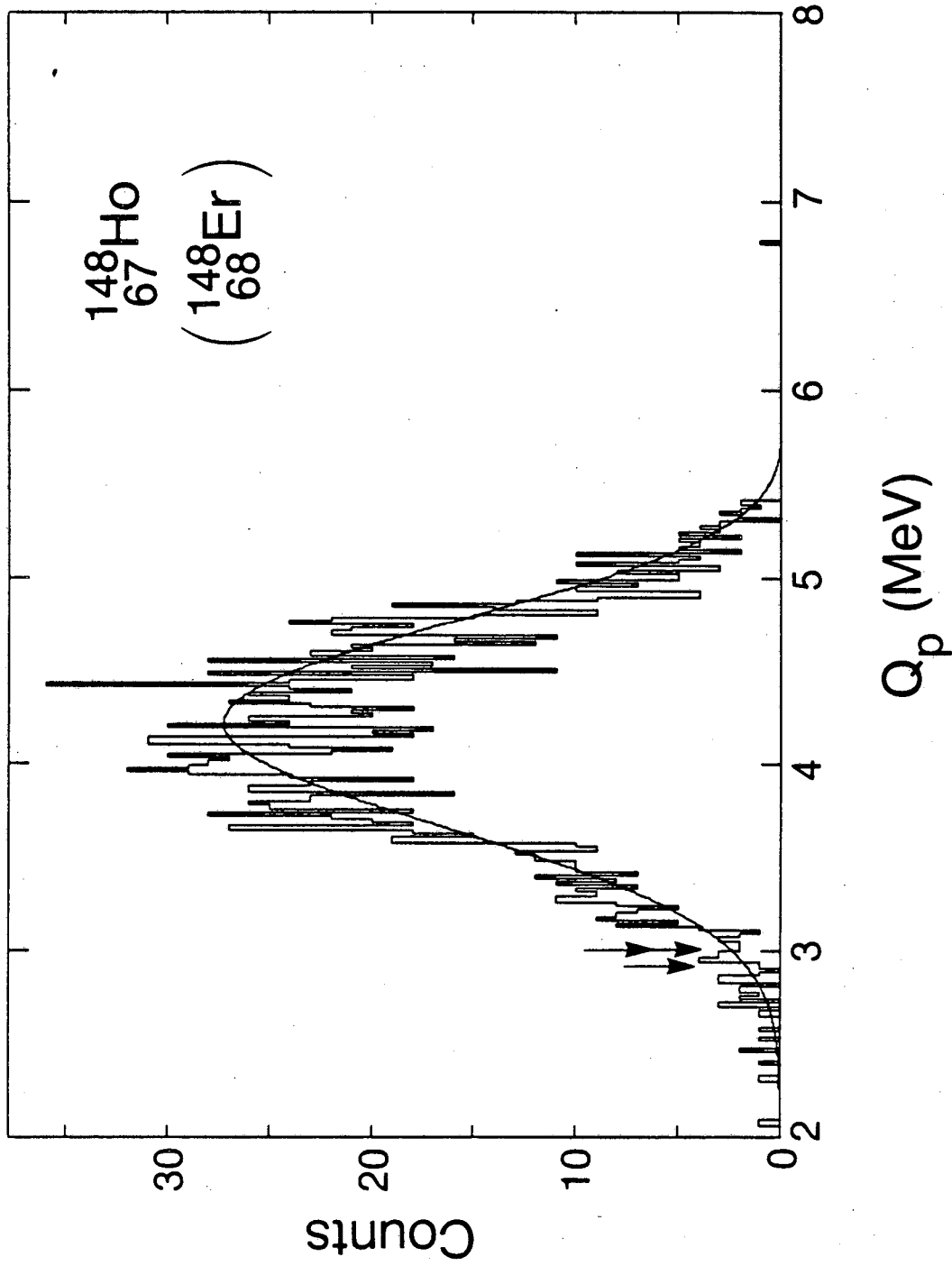
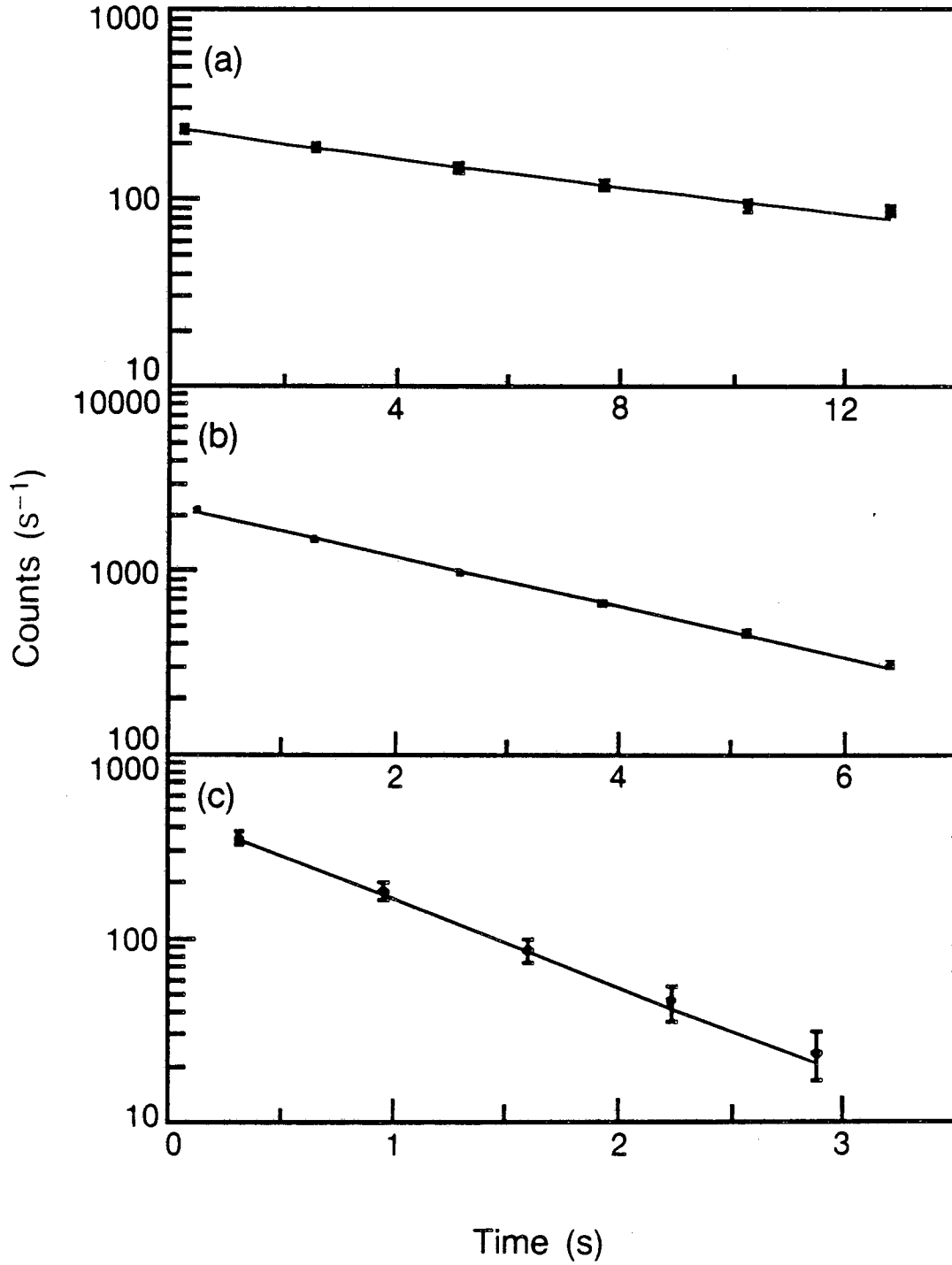

Figure 1



XBL 876-9708

Figure 2



XBL 876-9707

Figure 3

ORNL-DWG 87-8331R

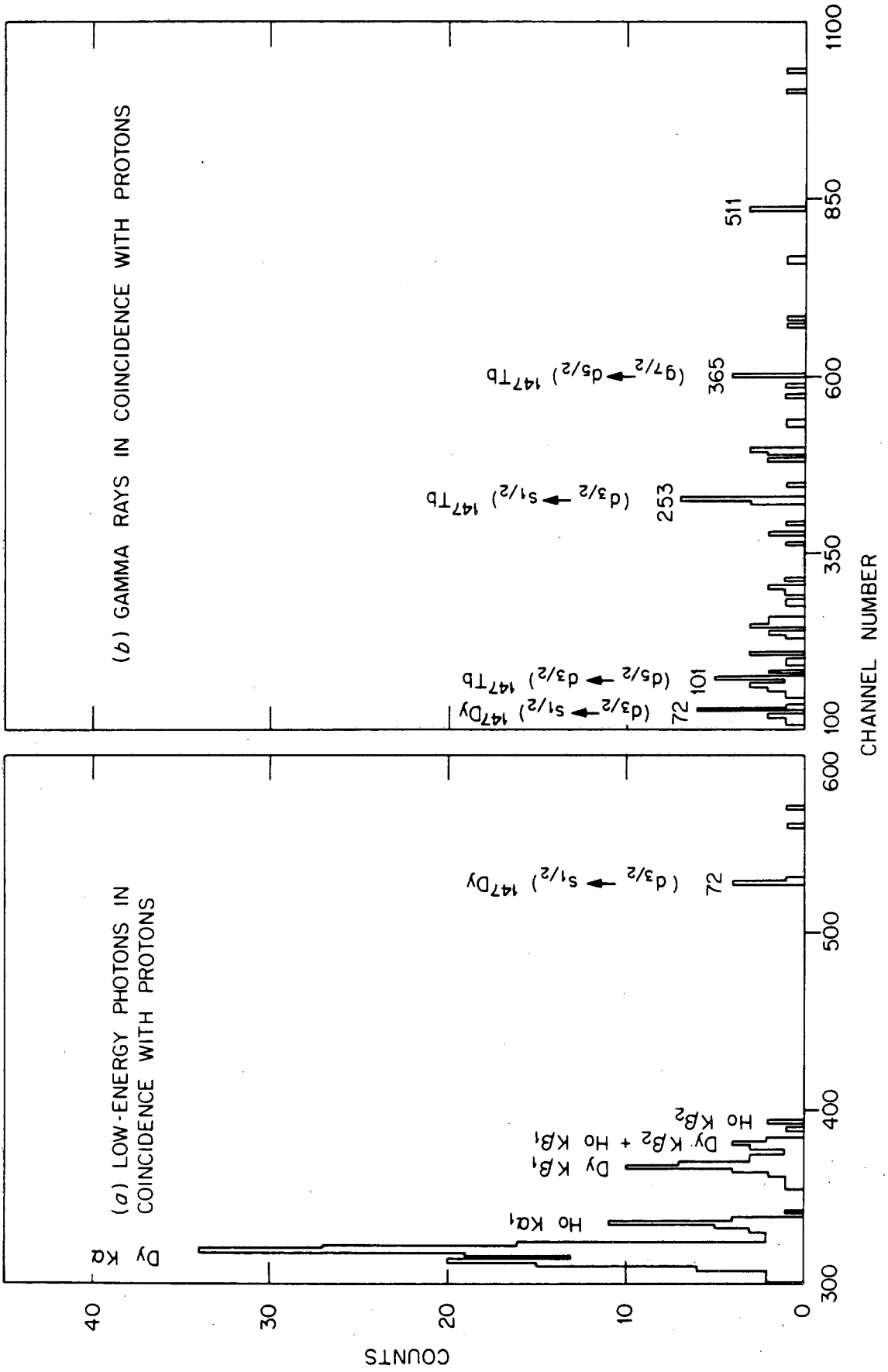
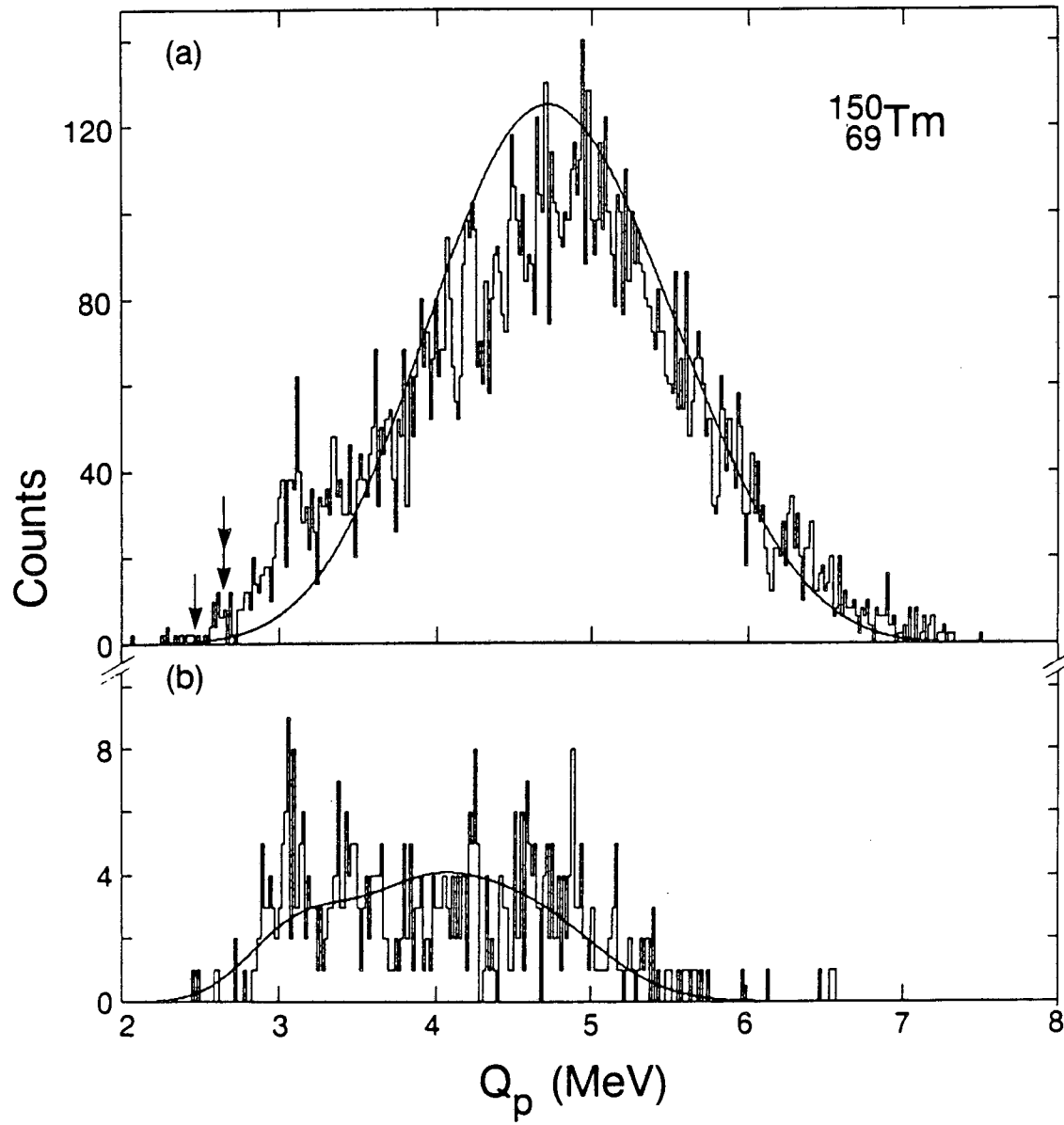

Figure 4



XBL 876-9709

Figure 5

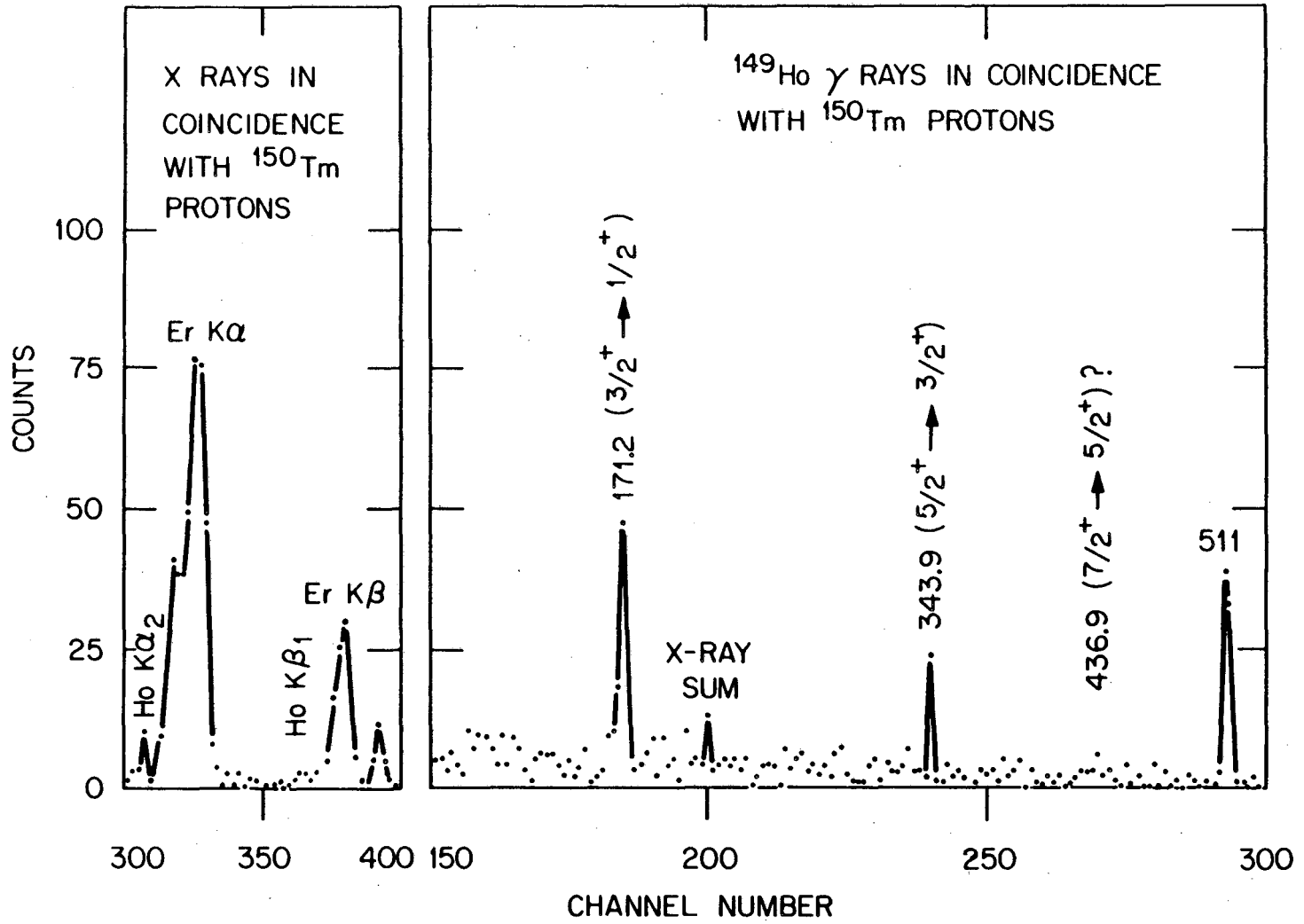
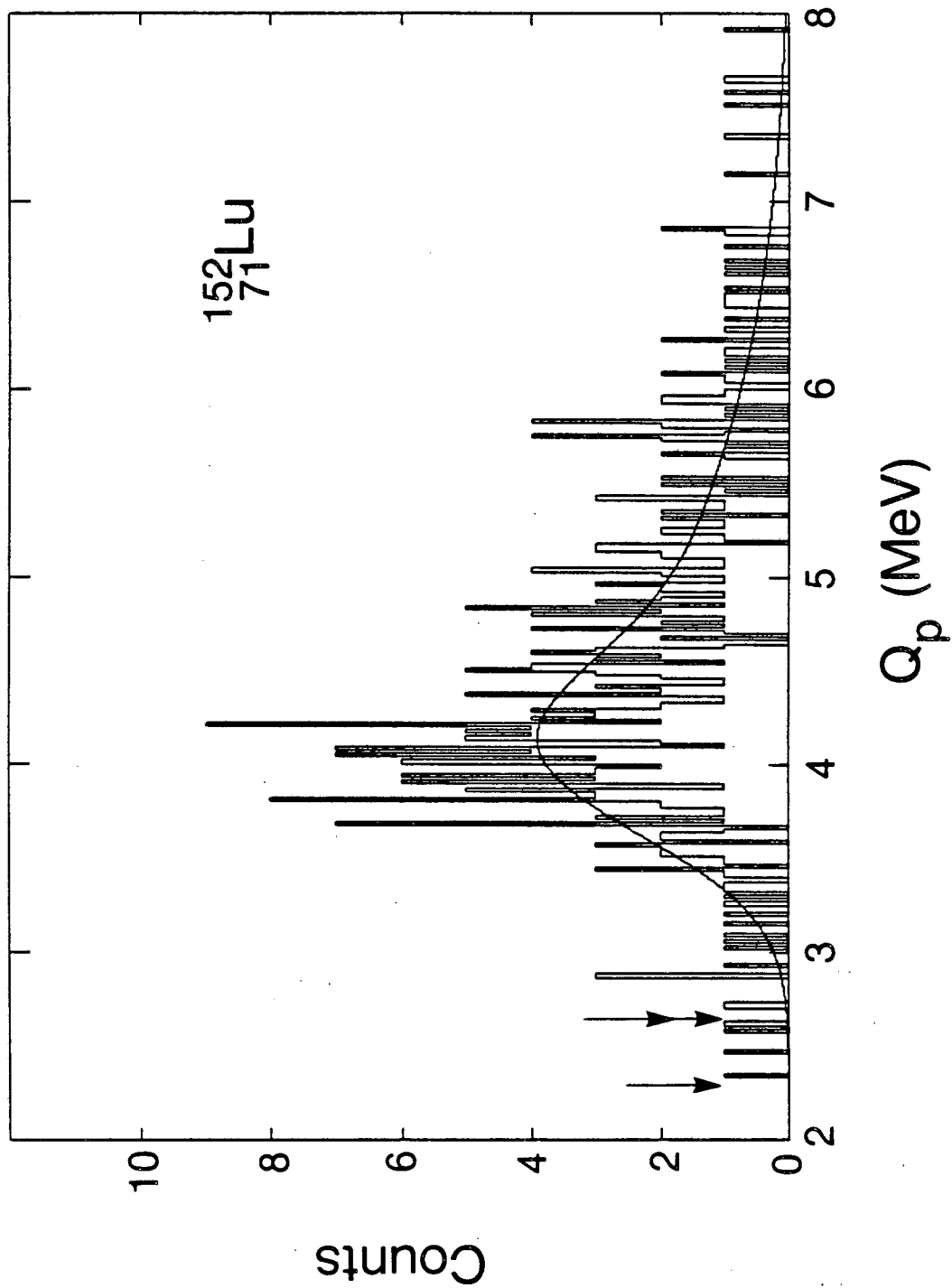

Figure 6



XBL 876-9706

Figure 7

*LAWRENCE BERKELEY LABORATORY
TECHNICAL INFORMATION DEPARTMENT
UNIVERSITY OF CALIFORNIA
BERKELEY, CALIFORNIA 94720*