

Lawrence Berkeley National Laboratory

Recent Work

Title

THE BEAM LINE X NDFE-STEEL HYBRID WIGGLER FOR SSRL

Permalink

<https://escholarship.org/uc/item/4fm1h9dz>

Author

Hoyer, E.

Publication Date

1987-03-01

c. 2



Lawrence Berkeley Laboratory

UNIVERSITY OF CALIFORNIA

Accelerator & Fusion Research Division

RECEIVED
LAWRENCE
BERKELEY LABORATORY

AUG 21 1987

Presented at the Particle Accelerator Conference,
Washington, DC, March 16-19, 1987

LIBRARY AND
DOCUMENTS SECTION

THE BEAM LINE X NdFe-STEEL HYBRID WIGGLER FOR SSRL

E. Hoyer, K. Halbach, D. Humphries, S. Marks,
D. Plate, D. Shuman, V.P. Karpenko,
S. Kulkarni, and K.G. Tirsell

March 1987

TWO-WEEK LOAN COPY
*This is a Library Circulating Copy
which may be borrowed for two weeks*

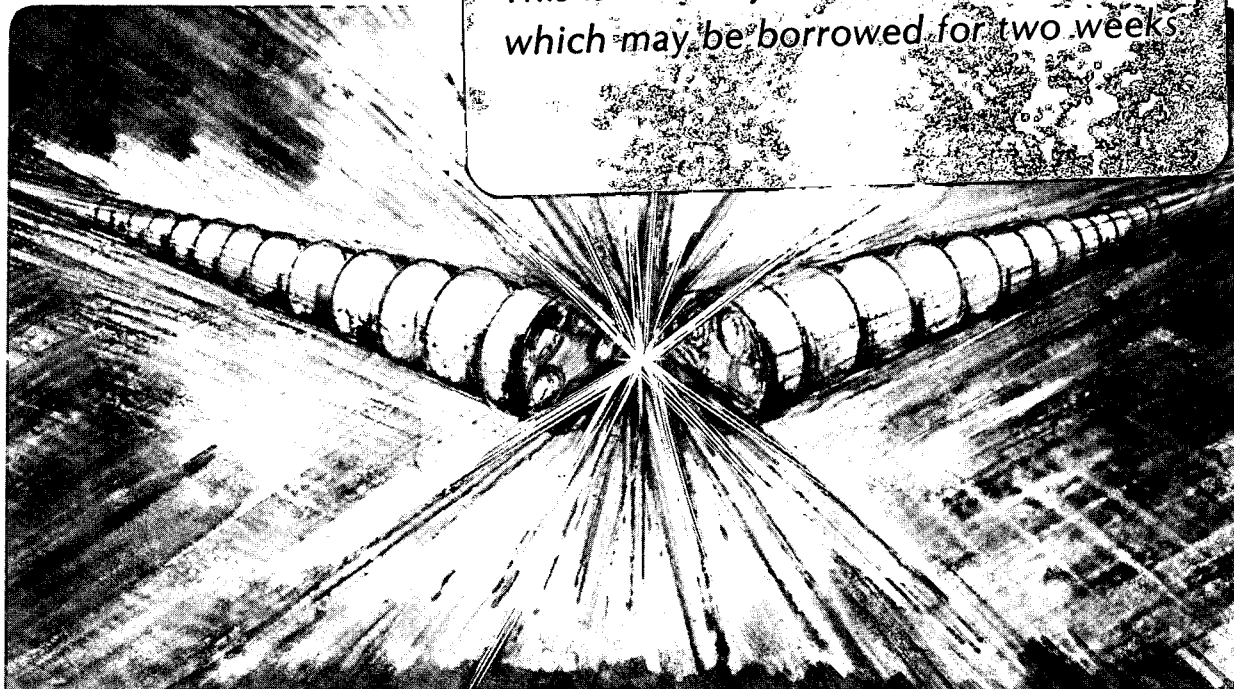

LBL-23053
c. 2

DISCLAIMER

This document was prepared as an account of work sponsored by the United States Government. While this document is believed to contain correct information, neither the United States Government nor any agency thereof, nor the Regents of the University of California, nor any of their employees, makes any warranty, express or implied, or assumes any legal responsibility for the accuracy, completeness, or usefulness of any information, apparatus, product, or process disclosed, or represents that its use would not infringe privately owned rights. Reference herein to any specific commercial product, process, or service by its trade name, trademark, manufacturer, or otherwise, does not necessarily constitute or imply its endorsement, recommendation, or favoring by the United States Government or any agency thereof, or the Regents of the University of California. The views and opinions of authors expressed herein do not necessarily state or reflect those of the United States Government or any agency thereof or the Regents of the University of California.

THE BEAM LINE X NdFe-STEEL HYBRID WIGGLER FOR SSRL*
 E. Hoyer, K. Halbach, D. Humphries, S. Marks, D. Plate, D. Shuman,
 Lawrence Berkeley Laboratory, University of California, Berkeley, 94720
 V.P. Karpenko, S. Kulkarni, K.G. Tirsell,
 Lawrence Livermore National Laboratory, University of California, Livermore, 94550

Summary

A wiggler magnet with 15 periods, each 12.85 cm long, which achieves 1.40 T at a 2.1 cm gap (2.26T at 0.8 cm) has been designed and is now in fabrication at LBL. This wiggler will be the radiation source of the high intensity synchrotron radiation beam line for the Beam Line X PRT facility at SSRL.

The magnet utilizes Neodymium-Iron (NdFe) material and Vanadium Permendur (steel) in the hybrid configuration to achieve simultaneously a high magnetic field and short period. Magnetic field adjustment is with a driven chain and ball screw drive system. The magnetic structure is external to a s.s. vacuum chamber which has thin walls, 0.76 mm thickness, at each pole tip for higher field operation.

Magnetic design, construction details and magnetic measurements are presented.

Introduction

This paper describes a NdFe-steel hybrid wiggler¹ designed and constructed at the Lawrence Berkeley Laboratory with installation at SPEAR planned for Summer 1987. The wiggler/undulator² is designed to provide an intense radiation source for the SSRL Beam Line X PRT facility being developed by LLNL, LANL, SNL, SSRL and UC.

The insertion device magnetic design parameters summarized in Table 1 were chosen as a compromise based on the following performance requirements:

- A horizontal fan of 5 mrad at 3 GeV for division into two or possibly three branch lines.
- A high critical energy to provide a broad energy range.
- A transverse vertical peak field tolerance of $\Delta B/B \leq 3\%$ for a 2.4 cm horizontal aperture.
- A maximum number of periods inserted into a SPEAR straight section for high photon intensity.
- A fixed gap vacuum chamber with an out-of-vacuum variable field magnetic structure.

Table 1. Beam Line X Insertion Device Parameters

Magnetic period length	12.85 (cm)
Number of complete periods	15
Operational Peak magnetic field	0.01 - 1.4 (Tesla)
Peak field uniformity	$\leq 2\%$ (at min. gap)
Operational Magnetic gap	2.1 - 20 (cm)
Beam vertical aperture	1.8 (cm)
Pole width	7.5 (cm)
Transverse field requirement	$\Delta B/B \leq 3\%$ (2.4 cm width)
Effective magnetic length	202.4 (cm)

The Beam Line X wiggler, though similar to the Beam Line VI Wiggler³ represents a more economical design. NdFe permanent magnet material was selected because it demonstrates higher gap magnet fields than REC⁴, exhibits less chipping, is easier to bond to common materials and is less expensive than REC. Only 1 remote drive system is provided for magnet gap adjustment with other adjustments either manual or eliminated, whereas 5 remote drive systems were provided on the BL VI wiggler. The vacuum chamber is of a "fixed gap" design as compared to the "variable gap" vacuum chamber design used on the BL VI wiggler.

Magnetic Design

Performance of the wiggler is dominated by the periodic structure, while the end poles correct for the finite termination of the periodic structure and enable null adjustment of beam deflection and displacement through the device.

*Work was supported by the Office of Energy Research, U.S. Department of Energy, Contract Nos. DE-AC03-76SF00098, and Division of Advanced Energy Projects and LLNL W-7405-Eng-48.

Hybrid wiggler magnetic design involves the design of the periodic structure consisting of a repetitive configuration of poles and permanent magnet material, and the end poles at each end of the magnet, consisting of poles, permanent magnet material and adjustable correction coils.

Periodic Structure Magnetic Design:

Figure 1 shows a single pole of the periodic structure configuration. The design is specified by dimensions for the pole width, W_p , permanent magnet block width, W_m , pole height, H_p , permanent magnet block height, H_m , pole length, L_p , and permanent magnet block length, L_m .

Design procedures account for the 3-D pole field distribution using a pseudo 3-D analysis. Effects of separate parameters are isolated so that they can be individually optimized. 2-D analysis was performed with the aid of PANDIRA⁵, a 2-D magnet code which accounts for the anisotropy of the permanent magnet material as well as the nonlinear permeability of the pole material, augmented with analytical calculations to account for 3-D effects.

With $\lambda/4 = W_p/2 + W_m$ given, the dimensions W_p and W_m were chosen to maximize the central field for the minimum operating gap. Pole height, H_p , and permanent magnet height, H_m , were determined to minimize the total volume of permanent magnet material consistent with the central field value. Transverse dimensions of the pole and permanent magnet material, L_p and L_m , respectively, were determined to meet the specifications on transverse field uniformity, and to reduce pole tip saturation and correct for excitation errors due to flux through the side pole surfaces.

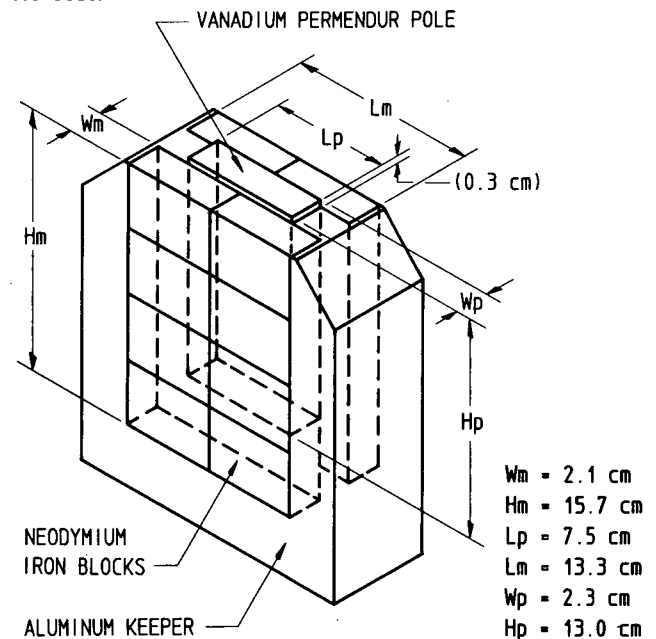

Figure 1. Half Period Pole Assembly

End Pole Magnetic Design

The requirements of net zero beam deflection and zero beam angle change are satisfied if the field integral is zero on both sides of the vertical midplane. To meet this condition, the end pole has a reduced amount of permanent magnet material and an adjustable correction coil to null the field integrals for operating gaps. Figure 2 shows the generic features of the end pole design. The permanent magnet dimensions were determined so that no current was required to null the field integrals at a 20.0 cm gap. Correction currents have been calculated for other operational gaps.

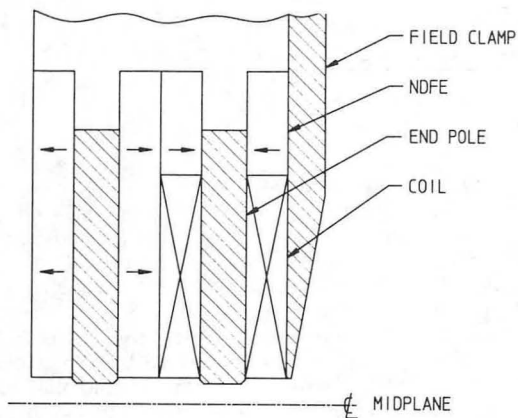

Figure 2. End Pole Configuration

Magnetic Structure

Prototype Pole

To verify the actual design configuration and selected material, as well as the periodic structure magnetic performance calculations, a prototype pole assembly was fabricated. The pole assembly was inserted into a steel test fixture, providing the appropriate magnetic boundary conditions, and measured magnetically. Magnetic measurements from the prototype are shown in Figure 3. For a 21 mm gap ($g/\lambda = 0.163$), the magnetic design calculations predicted a midplane central field of 1.45 Tesla; prototype magnetic measurements give 1.40 Tesla which is within 3% of the calculated value. Previous magnetic measurements⁴ of a 7 cm period linearly scaled model of this configuration gave 1.39 Tesla for the midplane central field demonstrating that permanent magnet structures scale linearly in dimension for a given field configuration.

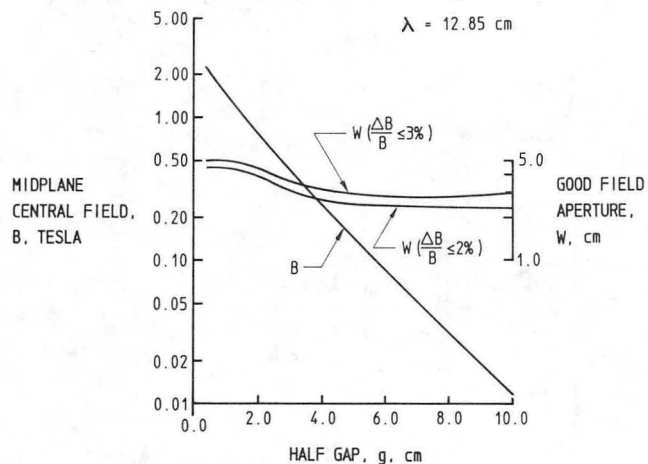

Figure 3. Prototype Pole Magnetic Measurements

Structure Configuration

Figure 4. shows the wiggler near completion. The magnetic structure consists of 2 wide flange beams to which each has 31 half period pole assemblies and two end pole assemblies attached.

The basic building block of this design is the half period pole assembly which consists of an aluminum keeper, a Vanadium Permendur pole (2.28 cm x 7.50 cm x 12.96 cm), and 16 NdFe blocks (2.07 cm orientation direction x 6.64 cm x 3.92 cm). Manufacture of these assemblies was carried out as follows:

1. NdFe blocks were ordered with magnetic specifications; $H_c \geq 10400$ Oersteds, a linear magnetization to 120% of H_c , a magnetic moment uniformity of all within $\pm 3.0\%$ and thermal stabilization at 50 deg. C for 3 hours⁶. The magnetic material was provided by Shin Etsu Chemical Co. Ltd.; the average $H_c = 11010$

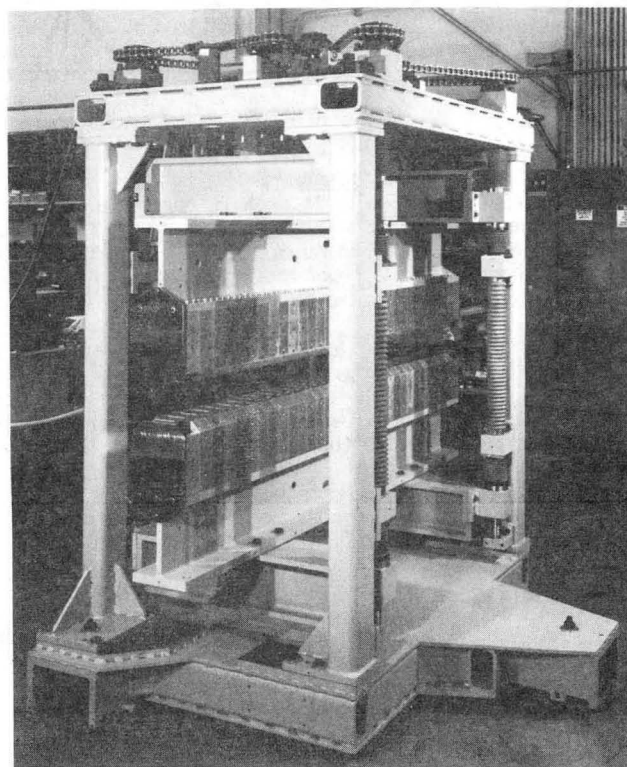

Figure 4. Beam Line X Wiggler

Oersteds and the uniformity $\pm 3.7, -3.2\%$ in 1135 blocks ($\pm 2.8, -2.6\%$ in 1088 blocks).

2. At LBL, the magnetic moment of each block was measured in three orthogonal directions. This information was then used by the code MSORT⁷ to arrange 1088 of the blocks into groups of eight with two groups associated with each half-period pole assembly. The sorting objective was to arrange the blocks into groups having the same average dipole moment. The measured block dipole moments were first normalized to a fixed reference temperature using a built-in temperature-dipole moment function and then subjected to a list of acceptability criteria. Next the blocks were monotonically ordered and paired, then the pairs, then the quads, and lastly the octads. The final group variation was .030%. The final step of the MSORT process was the generation of three-view orthographic assembly diagrams used to assemble each half period pole assembly.
3. The Vanadium Permendur poles were machined, heat treated in a vacuum furnace at 1100 deg. C for four hours and then finish machined. Each pole is pinned to its keeper with four stainless steel pins. Two dowel pins are provided in the back of each keeper to provide the required half period spacing of each pole assembly on the wide flange beam. Tapped holes (24) are provided in each keeper with s.s. set screws for block positioning.
4. The NdFe blocks are bonded into the pole assembly; the blocks are inserted into the pole assembly using a block holder and then held in place with a gluing fixture. The adhesive used is an LBL formulation: 100 parts Shell Epon 826 + 82 parts Henkel Versamid 115 + 2 parts Cab-O-Sil. Pole assemblies were cured for 16 hours at 40 deg. C.

The half period pole assemblies and end pole assemblies are bolted to the wide flange using a milling machine and pole assembly holding fixture. The poles are subsequently shimmed such that all the pole faces are aligned to a plane within ± 0.013 mm. Two 1/2 - 13NC steel bolts are provided at each pole assembly for tuning. Field clamps terminate the fringe field at each end. A flexible magnetic yoke (steel cable) connects the top and bottom wide flanges.

The end poles operate nominally at half the field of typical periodic pole assemblies and have water cooled correcting coils. The end poles have the same dimensions as the periodic poles, with mild steel used due to the lower maximum field requirement. Coil design uses 3/16" O.D. soft copper refrigeration tubing as a water cooled conductor to limit coil temperature rise to a few degrees C, thus limiting temperature fluctuation of the adjacent neodymium-iron. Each coil is 50 turns wound in three layers, insulated with woven fiberglass sleeving, and epoxy impregnated.

Support Structure/Drive System

Figure 4. shows the support structure and the drive system that controls the magnetic gap. The gap range is from 8 mm to 280 mm, with the operating gap set from 21 mm to 200 mm. This system includes a main frame supporting 4 right-handed ball screws on the upper section of the wiggler support structure and 4 left-handed ball screws on the lower half coupled by 4 intermediate shafts. The drive shafts are chain driven by a stepping motor coupled through a double worm gear reduction unit to increase torque. Power is supplied by a computer-controller, through a stepping motor translator. An absolute encoder is mechanically coupled to the drive system. System protection is accomplished with a torque limiter, limit switches and mechanical stops.

Vacuum Systems

The wiggler vacuum system shown in Figure 5 consists of a rigid vacuum chamber with side ports provided for mounting two fixed photon masks, two 220-liter/sec ion pumps with provisions for two more, one nude ion gauge and one right angle bakeable valve. The vacuum chamber internal dimensions are a vertical gap of 18 mm and a horizontal gap of 222 mm, 63.5 mm to the inside of the beam centerline and 158.5 mm to the outside. The horizontal gap offset provides an ante-chamber towards the outside of the SPEAR ring that prevents bending magnet radiation from striking the chamber walls but allows the two fixed masks at either end of the chamber to absorb the radiation produced by both electrons and positrons from the adjacent magnets. To maximize pumping efficiency, the ion pumps are located directly below the two fixed masks which are the major source of desorbed gases within the chamber.

The vacuum chamber was fabricated from two stainless steel plates, type 316L. The top and bottom chamber surfaces have thin sections at the pole tips, 0.76 mm thickness, machined into them to achieve the desired 21 mm minimum operational magnetic gap. The two halves have been mechanically welded together along the two inside seams to provide a recleanable vacuum chamber, one weld is on the neutral axis and the other is in the upper corner of the ante-chamber, to avoid cross welding of the side ports.

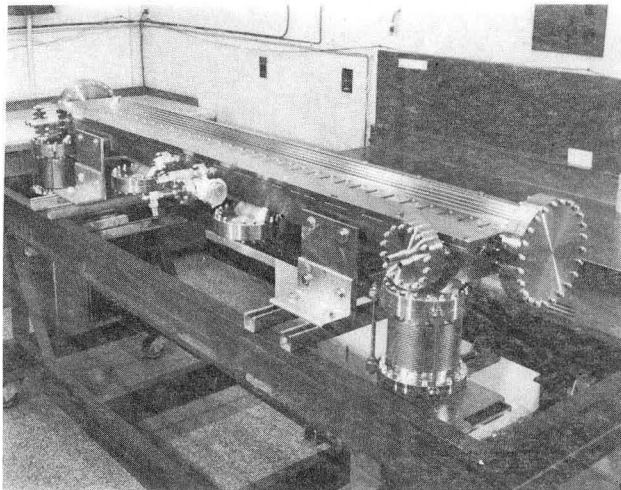

Figure 5. BLX Wiggler Vacuum Chamber

Flatness measurements were taken along the length of the 2 halves of the vacuum chamber before and after welding. Overall flatness of each half was 0.20 mm after machining, 0.43 mm after assembly and welding and 0.53 mm with vacuum applied.

Two transition spools, fabricated with bellows and conflat flanges, will be mounted on each end of the vacuum chamber. Each accommodates a low loss RF transition and four sensing elements that provide for electron beam position monitoring. The bellows allows for 32 mm compression for SPEAR ring bakeout and simultaneously a ± 3 mm transverse movement of the vacuum chamber.

Magnetic Measurements

Upper and Lower Magnetic Structure Measurements

Hall probe and 1 period integral coil magnetic measurements were carried out on both the upper and lower magnetic structures individually without completed end poles. Data below is for the central 25 poles.

Hall Probe Measurements: 25 measurements taken twice, 5 mm from the pole surfaces.

Magnetic Structure	Average Field (Tesla)	Variation ($\pm 1\sigma$) (%)
Upper	0.6965	0.232
Lower	0.6963	0.136

1 Period Integral Coil Measurements: 13 measurements taken in each direction, 6 mm from the pole surfaces.

Magnetic Structure	Sum of 13 Coil Measurements (q-cm)	Variation ($\pm 1\sigma$) (gauss-cm)
Upper	-70.	147.
Lower	-124.	100.

Assembled Magnetic Structure Measurements

Preliminary magnetic measurements, similar to the above, were carried out for the central 25 poles of the assembled structure without the flexible yoke and final alignment, at an 18 mm gap. Hall probe data for the midplane central field, 25 measurements taken twice, gives an average field of 1.6086 Tesla with a variation ($\pm 1\sigma$) of 0.236%. 1 period integral coil measurements yield for a sum of 13 measurements in each direction, -682. gauss-cm with an individual coil measurement variation, ($\pm 1\sigma$) of 283. gauss-cm.

Acknowledgements

The authors thank C. Poppe, K. Berkner and M. Howells for project support and J. Cerino, B. Gath, J. Meneghetti, M.I. Green, D. Nelson, J. Wirth, and laboratory shop personnel for their assistance.

References

1. K. Halbach, Proc. Free Electron Laser Conf., Bendor, France (1982).
2. K.G. Tirsell, et al., Development of a NdFe-Steel Hybrid Wiggler for SSRL, Proc. Int. Conf. on Insertion Devices for Synchrotron Sources, SPIE Vol. 582, 177, (1985).
3. E. Hoyer, et al., The Beam Line VI REC-Hybrid Wiggler for SSRL, IEEE Trans. NS-30, 3118, (1983).
4. K. Halbach, et al., CSEM-Steel Hybrid Wiggler/Undulator Magnetic Field Studies, IEEE Trans Vol. NS-32, 3640 (1985).
5. PANDIRA is an improved version of POISSON which allows solution of permanent magnet and residual field problems. POISSON is an improved version of TRIM (A.M. Winslow, J. Computer Phys. 1, 149, 1967) that was developed by K. Halbach, et al.
6. D. Shuman, Magnetized Neodymium-Iron Blocks, LBL Specification M665A, (1985).
7. D. Humphries, MSORT, A Sorting and Data Management Code for Hybrid Wiggler/Undulators, LBL Engr. Note M6629, (1987).

*LAWRENCE BERKELEY LABORATORY
TECHNICAL INFORMATION DEPARTMENT
UNIVERSITY OF CALIFORNIA
BERKELEY, CALIFORNIA 94720*