

UC Davis

White Papers

Title

Freight Efficiency Strategies: Operational Modernization at Distribution Nodes

Permalink

<https://escholarship.org/uc/item/4fq9f0qv>

Authors

O'Brien, Thomas
Reeb, Tyler

Publication Date

2016-03-01

FREIGHT EFFICIENCY STRATEGIES: OPERATIONAL MODERNIZATION AT DISTRIBUTION NODES

March 2016

A White Paper from the Freight Efficiency
Strategies Development Group

Lead Authors:

Thomas O'Brien, California State University Long Beach

Tyler Reeb, California State University Long Beach

Working Group Members: **Alison Bird**, FedEx; **Mike Christensen**, Port of Long Beach; **Richard Coyle**, California Trucking Association; **Lee Kindberg**, Maersk Line; **David Litbatique**, Port of Los Angeles; **Peter Okurowski**, California Environmental Associates; and **Elizabeth Fretheim**, Walmart



National Center
for Sustainable
Transportation

METRANS
Transportation Center
USC | CSULB

About the Freight Efficiency Strategies Development Group

In July 2015, Governor Jerry Brown issued Executive Order B-32-15, directing several state agencies to work together in developing an integrated action plan that will “establish clear targets to improve freight efficiency, transition to zero-emission technologies, and increase competitiveness of California’s freight system” and that the plan should “identify state policies, programs, and investments to achieve these targets”. In response, an interagency group was formed to oversee the development of the California Sustainable Freight Action Plan (CSFAP). Members of the interagency group include the California Air Resources Board, the California Department of Transportation (Caltrans), the California Energy Commission (CEC), and the Governor's Office of Business and Economic Development (GO-Biz). As part of developing the plan, the interagency group has solicited feedback from a broad range of stakeholders through a variety of engagement activities and outreach efforts. A component of this engagement was the development of the Freight Efficiency Strategies Development Group (FESDG) made up of freight experts from academia, industry, and government. The purpose and main task of this group was to produce a series of white papers that identify promising strategies for increasing the efficiency of the freight system. A series of six papers were developed over the course of six months. Each paper focuses on a specific theme for increasing freight efficiency within the larger freight system.

About the National Center for Sustainable Transportation

The National Center for Sustainable Transportation is a consortium of leading universities committed to advancing an environmentally sustainable transportation system through cutting-edge research, direct policy engagement, and education of our future leaders. Consortium members include: University of California, Davis; University of California, Riverside; University of Southern California; California State University, Long Beach; Georgia Institute of Technology; and University of Vermont.

Disclaimer

The content of the white papers produced by the group represents discussions among many individuals representing various freight industry stakeholders. It may not reflect consensus on the part of all of the participants, nor do these papers necessarily represent the official opinion or policy of the represented organizations, but rather a range of thinking that might be used to inform and build consensus for the development of the California Sustainable Freight Action Plan. Given the perspective of the various freight stakeholders, paper authors have attempted to include dissenting opinions and areas of concurrence where they may exist. This document is disseminated under the sponsorship of the United States Department of Transportation’s University Transportation Centers program, in the interest of information exchange. The U.S. Government and the State of California assumes no liability for the contents or use thereof. Nor does the content necessarily reflect the official views or policies of the U.S. Government and the State of California. This report does not constitute a standard, specification, or regulation.

Acknowledgments

This study was funded by a grant from the National Center for Sustainable Transportation (NCST), supported by USDOT and Caltrans through the University Transportation Centers program. The authors would like to thank the NCST, USDOT, and Caltrans for their support of university-based research in transportation, and especially for the funding provided in support of this project. . The authors and working group members are grateful for the assistance of the following California State University, Long Beach students who conducted research and provided information in the development of this white paper: Orion Gould, Daniel Magno, and Jennifer Tran.

[page left intentionally blank]

TABLE OF CONTENTS

EXECUTIVE SUMMARY iii

Introduction..... 1

Theme 1: Energy Efficiency At Marine Terminals 1

 Statement of the Problem..... 2

Theme 2: Improved Truck Access At Nodes..... 12

 Truck Platooning 12

 Virtual Container Yards 19

 Design-based Guidelines 22

 Weigh-in-Motion 31

Conclusion 37

References 39

Operational Modernization at Distribution Nodes

EXECUTIVE SUMMARY

This white paper documents obstacles preventing operational modernization at trade nodes and then recommends strategies to address those challenges in ways that address the State of California’s goals to improve freight efficiency, economic competitiveness, and environmental sustainability. All of the strategies outlined in this report are intended to inform next steps in the development of the California Sustainable Freight Action Plan.

The first of those recommended strategies focuses on establishing energy independence at marine terminals through the use of energy microgrids. Using microgrid technology, marine terminals can become self-sustaining “energy islands” capable of independently generating their own energy supplies separate from legacy energy grids to maintain ongoing operations. In the event of natural or manmade disasters, marine terminals with energy grids could continue operations even if the main power grid in the region collapses. Additionally, marine terminals could sell excess electricity generated by their microgrids back to the main power grid in their respective region. Implementation of energy grids requires considerable financial investment as well as new partnerships with governmental and industry stakeholders. This white paper also explores ways to incentivize “buy-in” for energy grids into existing energy markets.

In addition to addressing the importance of energy efficiency and independence at distribution nodes, this white paper also addresses the importance of improving truck access at distribution nodes in a manner that addresses the three interrelated goals outlined in Gov. Brown’s executive order: economic competitiveness, movement toward zero emissions, and operational efficiency. To promote improved truck access at distribution nodes, the research investigated the use of truck platooning, virtual container yards, design-based guidelines, and weigh-in-motion strategies to improve freight efficiency.

Truck platooning involves a train of trucks traveling together at very close proximities to lower fuel costs and increase efficiency. Through the use of advanced wireless communication technologies, the second driver, third driver, and any subsequent drivers are able to brake at the same time as the first driver who controls the speed and pace of the train of trucks. Although further research, regulations, and technological advances are required for widespread implementation where any truck can join a convoy or train, potential benefit of this practice on diesel consumption, the environment, and the economy is significant.

Likewise, the effect of virtual container yards (VCY) on freight efficiency holds the potential of introducing new efficiencies into the freight transportation network. Despite the many technological advances in freight, truckers continue to transport empty containers when they return or pick-up goods. Carrying empty containers in this manner wastes time and money for drivers and companies; it also increases carbon dioxide emissions and unnecessary fuel consumption. However, implementation of VCYS can eliminate this inefficiency. VCY leverages

internet-based systems to locate empty containers in real-time and facilitates exchanges without the use of a physical container yard or distribution node.

The design-based guidelines outlined in this paper address physical design elements at distribution nodes that either aid or impede freight. Aside from designing facilities for truck types, loads, ease of movement and maneuverability, freight routes, and parking and loading zones at distribution nodes, design-based guidelines should be taken into account for routes within metropolitan areas connecting distribution nodes. Inefficient truck movements caused by poorly designed distribution nodes can have a similar negative net effect on the movement of goods, the economy, and the environment. Implementing design-based-guidelines at truck nodes can not only promote modern efficiencies but also increase safety for all modes of transportation, maintain truck mobility and access, and reduce negative environmental impacts.

To further ease movement between distribution nodes, this white paper also assesses the potential benefits of weigh-in-motion technologies. Traditionally, freight faces delays with the enforcement of weight limits. However, weigh-in-motion technology allows truckers to meet regulations while en route to their destinations. This not only eliminates travel time and the costs associated with it, but also increases overall freight safety, reduces equipment and highway damage, and curbs harmful air emissions. This White Paper concludes with recommendations that inform next steps in the development of the California Sustainable Freight Action Plan.

Introduction

This White Paper presents best practices and recommendations on operational modernization at distribution nodes to increase the efficiency of California’s multimodal freight system. The Efficiency Strategies Development Group (EFDG) scope document states:

“This Think Tank will be focused on opportunities for Federal, State and local policies and the private sector to remove system-wide barriers to the efficient movement of freight.”

Toward that end, this document seeks to identify the interrelated factors that lead to congestion and bottlenecks at trade nodes that negatively impact the broader supply chain. Those challenges include, but are not limited to, obsolete infrastructure, lack of convenient access to optimal fuel and energy sources, technological barriers, funding difficulties, lack of industry engagement, and lapses in design and planning. After describing the obstacles preventing operational modernization, this paper will recommend strategies to address those challenges in ways that address the State of California’s goals to improve freight efficiency and environmental sustainability.

Theme 1: Energy Efficiency At Marine Terminals

Port facilities require a tremendous amount of energy to power the broad range of transportation systems required to move freight in and out of terminals. As such, this puts a burden on legacy energy grids. To address the economic and environmental challenges facing California’s ports related to freight efficiency, the California Energy Commission and five ports spanning northern and southern California formed the Ports Energy Collaborative. The Ports Energy Collaborative provides a forum for the Commission and the ports to discuss important energy issues, mutual challenges, and opportunities for transitioning to alternative and renewable energy technologies (Ports Energy Collaborative California Energy Commission, 2016).

Using the Port of Long Beach’s Energy Island systems approach, and the Port of Los Angeles’s planned development of a port microgrid that is powered by the Los Angeles Department of Water and Power (LADWP) Harbor Generating Station (Port of Los Angeles, 2014), the ports seek to become self-sustaining facilities. Introducing microgrids into marine terminals is a new concept, therefore there is no significant body of literature addressing such implementation. To address this challenge, the research began with a careful review of Port of Long Beach Energy Island planning documents, the Port of Los Angeles’ planned development of a port microgrid, and correlated those findings with existing literature on the study of microgrids, which is a concept for which a larger body of research exists (particularly as a response to the damage and fallout connected to the struggling power grid on the East Coast after Hurricane Sandy). In this way, the forthcoming research on microgrids at marine terminals could also be applied to smaller marine terminals, airports, concentration terminals, and distribution centers.

Statement of the Problem

The ports of Long Beach and Los Angeles have made commitments to use the best available technologies to avoid or reduce negative environmental impacts and promote sustainability, which has resulted in significant increases in electrical equipment. Reducing air emissions has become a priority for industry stakeholders across the supply chain, not just port operators. Industry stakeholders have made investments to meet the State’s Vessel at-berth regulations, and ocean-going vessels are required by law to reduce emissions while at-berth via shoreside power or an alternative method.

As the ports of Long Beach and Los Angeles move toward zero-emission goals, reliance on electrical power has dramatically increased, and on-terminal electricity usage is predicted to quadruple by 2030 compared to 2005 (Port of Long Beach, 2015). Thus, “electrical demands are increasing for management of the logistics of goods” (Parise, Parise, Martirano, Chavdarian, Su, and Ferrante, 2016). The Los Angeles and Long Beach ports require tremendous amounts of energy to power the broad range of transportation systems required to move freight in and out of terminals as shown in Table 1 which lists the energy consumptions of both ports in 2012.

TABLE 1
ENERGY CONSUMPTIONS OF LOS ANGELES AND
LONG BEACH PORTS IN 2012

Period 2012	Port of Los Angeles	Port of Long Beach
Total Annual Energy Consumption	200,000 to 250,000 MWh	150,000 to 200,000 MWh
Peak Hourly Average Demand	50 to 60 MW	40 to 50 MW
Minimum Hourly Average Demand	17 MW	15MW
Annual Average Demand	27 MW	21 MW
Total Annual Cost of Demand and Energy	\$28 to 32 MM	\$18 to 22 MM

(Parise, Parise, Martirano, Chavdarian, Su, and Ferrante, 2016)

Marine terminals put a tremendous burden on aging electrical energy grids, and ports face vulnerabilities to potential regional power outages that would hinder freight transportation. Therefore, it is imperative that the ports of Los Angeles and Long Beach develop a plan of action “to improve the overall power profile of Port operations in a manner that is protective of the natural environment and the Port’s continued economic viability and national competitiveness” (Port of Los Angeles, 2014). Furthermore, an adaptive, flexible action plan is needed due to advances and changes in technology and operations, making any “energy management” an “ongoing process” (Port of Los Angeles, 2014).

With the implementation of the Port of Long Beach’s Energy Island systems approach, ports can become “islands” of sustainable energy generation by using microgrids and energy storage systems. This solution will address the ports’ increasing demand for electricity as it transitions to more environmentally sustainable equipment. In addition, the development of an

organizational foundation and programs, policies, and studies similar to the “Energy Team” and the “Port Energy Policy” in the Port of Los Angeles will provide the necessary leadership and support to improve overall efficiency, reliability, and resiliency of energy operation and management (Port of Los Angeles, 2014).

Description

The Port of Long Beach’s Energy Island Initiative seeks to “provide reliability, resiliency, and economic competitiveness to the Long Beach port complex and its marine terminal tenants via localized power generation and adequate fueling infrastructure to support clean transportation options” (Port of Long Beach, 2015). To accomplish this, the Initiative will create an “island” of renewable energy technologies with modular self-generation systems that utilize low carbon technologies, and load-controlling energy storage strategies (Port of Long Beach, 2015). A notable part of this Energy Island Initiative is the integration of intelligent storage systems in smart microgrids.

Microgrids are subsets of a greater grid and usually include their own energy generation, demand, and the ability to modulate priority energy distribution or storage (Chan, 2012). It can be as small as 100 kilowatts or as large as 100 megawatts. According to Parise, Parise, Martirano, Chavdarian, Su, and Ferrante (2016), smart microgrids are the “most revolutionary innovation” with the ability to reverse utilization of the shore-to-ship or ship-to-shore electrical power or storage, and in the future, docked ships may be local generators that can supply great quantities of energy¹ to the port grid or regional main grid. Smart microgrids are necessary for ports to optimally manage the energy flows and make grids efficient and self-sustainable systems (Martirano, Falvo, Sbordone, Arboleya, Gonzalez-Moran, Coto, Bertini, and Pietra, 2013). Below is an overview of the main components in a common microgrid:

¹ The creation of “great quantities” of energy is not conceivable in consideration of the purpose of the State’s at-berth regulations, which is to eliminate vessel emissions – regardless of the technical ability of vessels to do so or the desire to create energy independence.

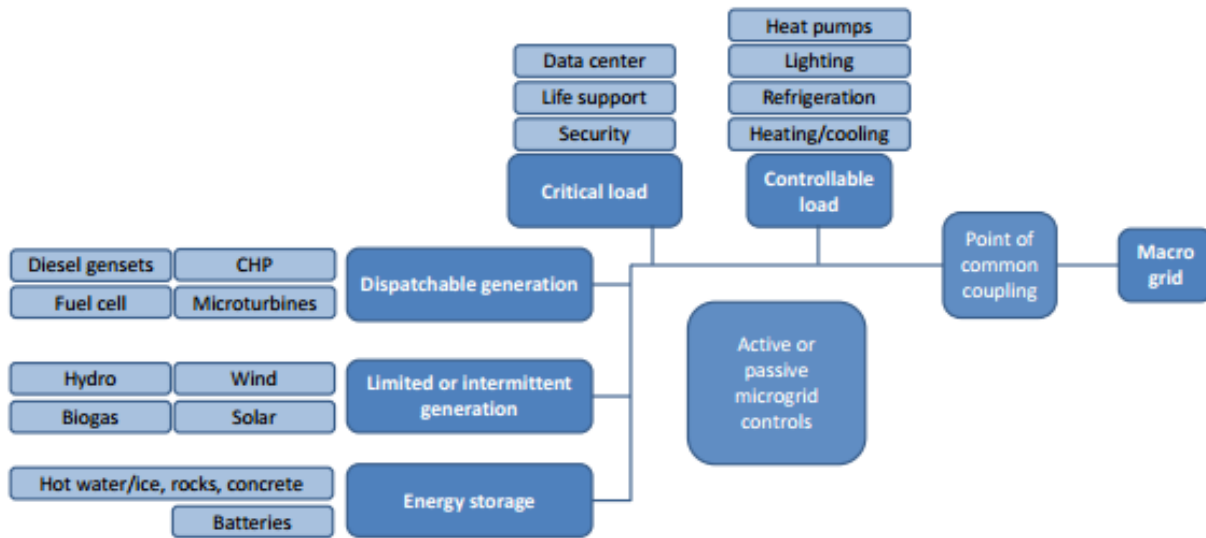

(Romankiewicz, Qu, Marnay, and Zhou, 2013)

Furthermore, smart microgrids are unique as they intelligently coordinate and balance different energy production technologies. When the microgrid detects a drop in solar generation for example, it can increase production elsewhere or reduce energy distributed in noncritical areas of the port to make up for the difference. Likewise, if wind generation exceeds demand, the microgrid can charge additional electrical vehicles or store the excess energy for later uses. “This intricate dance among supply, demand, and storage can enable a cleaner and more resilient future” (Chan, 2012). By using smart microgrids and storage systems, ports are able to take the form of an electrical “island” and ensure smooth production and distribution of electricity.

Developing sustainable sources of electricity are also featured in the Port of Los Angeles’s Energy Management Action Plan (2014). “Integration of energy management practices and renewable power generation to minimize the depletion of natural resources and provide economic, social, and environmental benefits,” is a stated goal. “Opportunities exist to strategically reduce greenhouse gas (GHG) emissions from terminal operations by either importing green electricity from LADWP renewable energy sources or generating clean energy at the Port. Local generation options that reduce GHG emissions can include natural gas-fired combined heat power (CHP), solar, wind, and offshore wind and wave energy.” Toward that end, the City of Los Angeles Harbor Department’s (Harbor Department) Photovoltaic (PV) Solar Power Program emerged from a partnership between the California Attorney General (AG), the Mayor of the City of Los Angeles, and the Harbor Department to reduce greenhouse gasses and support the Port of Los Angeles (Port) Clean Air Action Plan (CAAP). One of the goals of the partnership is for the Harbor Department to install 10 megawatts (MW) of PV solar power within the port, or other land owned by the Harbor Department, by the end of calendar year 2012 in two phases. Phase One would be the direct purchase of a one MW PV solar power system (PV System) by the Harbor Department for operation under the City of Los Angeles Department of Water & Power’s (LADWP) Net Energy Metering (NEM) Program. Phase Two

would be the installation of the remaining nine MW through a series of Request for Proposals (RFP) to solar power developers who would take advantage of federal, state, and LADWP incentives and operate the PV Systems under a future LADWP power purchase agreement (PPA) program.

As of February 2016, the Harbor Department has 1.6 MW of PV solar power installed within the Port's boundary. Since the Harbor Department was behind schedule to meet its 10 MW goal for various reasons, it requested and was granted an amendment to its partnership with the AG. The amendment details a path under which the Harbor Department would meet its 10 MW commitment by the end of calendar year 2018. At present, another 1.3 MW of PV solar power are under construction and 13.4 MW are under development through a combination of Harbor Department, Harbor Department tenant, and solar power developer projects. The Harbor Department anticipates it will both meet and exceed its 10 MW goal by the end of calendar year 2016.

With the implementation of microgrids, the architecture of the ports' electrical system must be considered as it significantly impacts the performance of the system. The structure can become increasingly complicated based on port area configuration, power sources (utility and renewable), and different power demands from varying equipment. There must also be plans for maintainability, flexibility, expandability (Parise, Parise, Martirano, Chavdarian, Su, and Ferrante, 2016).

Another part of the Port of Los Angeles' *Energy Management Action Plan (2014)*, is to form the "Energy Team" and establish the "Port Energy Policy." The main purpose of the Energy Team is to verify that projects and policies under the plan are implemented and followed. The Energy Team essentially serves as purveyors for the Port Energy Policy and the management of operations and energy at the Port. Under the plan, the team leader, or "project manager," is also responsible for creating plans to engage "key stakeholders" in the advancement of projects and other actions. To do so, the Energy Team consists of individuals from business development, engineering, government affairs, information technology, real estate, and legal, along with "experts knowledgeable in energy management and port operations" (Port of Los Angeles, 2014). Aside from the members' expertise in energy management and port operations, the Energy Team is strategically comprised of individuals with a range of skills and knowledge to accomplish a wide variety of tasks, such as:

- Coordinate with LADWP to plan, develop, finance, and implement energy infrastructure improvements;
- Collaborate with POLB on joint Port energy efforts;
- Develop and manage stakeholder outreach;
- Work with local, state and federal regulatory agencies;
- Oversee and manage studies and modeling efforts required to develop an Energy Master Plan;
- Manage energy-based technology programs;

- Develop and manage Port incentive plans;
- Serve as the Port interface with electricity and gas providers;
- Evaluate the findings and recommendations of energy-related studies;
- Develop education and outreach programs to increase energy awareness;
- Develop energy management best practices and training programs;
- Evaluate projects based on alignment with Port Energy Pillars;
- Identify and secure funding opportunities; and
- Adaptively manage the EMAP to take advantage of lessons learned, new technologies, and operational approaches” (Port of Los Angeles, 2014).

Aside from pushing the *Energy Management Action Plan* forward, the Energy Team is also responsible for improving collaboration with LADWP, port tenants, and other important stakeholders (Port of Los Angeles, 2014).

In terms of freight efficiency, this means the implementation of electricity-driven ports and greater terminal automation. This can increase freight efficiency and better address congestion management at distribution nodes. Also, with the implementation of an electrical port run by microgrids, there will be greater incentives and demand to use smarter vehicles that cause less traffic disruption and more efficiency through bottlenecks (American Highway Users Alliance, 2015). This is especially true when paired with an Energy Team that can manage energy and operations at ports and distribution nodes, and are already familiar with the research, evaluation, and implementation in the growing field of intelligent transportation systems (ITS) technologies in trucking. Furthermore, having a team of experts devoted to energy and freight will help ports like Los Angeles reach their goals in resiliency, availability, reliability, efficiency, and sustainability in freight efficiency.

Expected Benefits

There are many benefits for ports and distribution nodes leveraging microgrids’ capability to balance one or more local power generation sources and self-sustaining nature. Benefits include:

- integration of renewable energy sources and reduced environmental impact,
- protection for critical infrastructure from power loss and maintaining operations during outages, and
- efficient management of energy production and consumption (Wartian & Putnam, 2013).

These benefits lend themselves to dependable, local energy efficiency and management, and enhanced safety and reliability. Real-world examples of microgrid reliability and resiliency are shown in Korea, Denmark, California, and Hawaii where microgrids have been stress-tested annually. This means that microgrids were disconnected from the greater or main regional grid,

and despite that, were able to meet peak power demands from its “island” of energy production and storage.

Another example occurred in 2009 in San Diego. When the rest of the San Diego utility grid was threatened by wildfires, the microgrid at the University of California, San Diego, continued to supply electrical energy to the university’s lighting system (Chan, 2012). The Halifax Port Authority announced its plan to be the first port in Atlantic Canada to provide shore power in 2013. Its goal was to provide shore power in 2014 and allow ships to plug in and turn off their auxiliary engines. Vessels are usually in port for approximately nine hours, and will emit no carbon dioxide, mono nitrogen oxides, sulfur oxides, or particulate matter from auxiliary generators while connected to shore power. This will dramatically reduce the Port of Halifax’s harmful air emissions (Sain, 2014).

A major expected benefit of implementing an Energy Team (as called for in the Port of Los Angeles *Energy Management Action Plan* [2014]), is that specific metrics and goals become viable for prioritization and tracking of various energy management and operation projects and studies. This will better position ports to reach their goals in resisting power outages, enhance recovery capabilities from natural disasters or grid outages, meet future power demands, minimize disruptions in operations, reduce energy usage and costs, and reduce harmful emissions. By assigning specific metrics of measurement to the selected criteria established in the energy management policy, specific, realistic, and obtainable goals can be determined. For instance, the Port of Los Angeles sets specific metrics to pinpoint when and where certain “power events” take place within the port. It also analyzes which individual tenants are affected by these power events, and how this effects the overall power system. The Port of Los Angeles encourages the Harbor Department and all the port’s tenants to record and track all data, so that benchmarks for energy consumption may be set and utilized for future planning (Port of Los Angeles, 2014).

How Microgrids Can Promote Freight Efficiency

How can energy efficiency at marine terminals promote freight efficiency? The answer to this question requires a broad understanding of Gov. Jerry Brown’s executive order that calls for a new freight initiative that addresses three interrelated goals: economic competitiveness, a move toward zero emissions, and operational efficiency. If these three goals are to be reached, policy and planning efforts to bring those goals to fruition must be coordinated and reinforced rather than detract from each of the three individual goals.

In addition, implementation of microgrids may be cost-effective and improve the local economy by attracting new businesses, prompting quality jobs, advancing new technologies, and increasing customer retention (Port of Long Beach, 2013). For instance, Chevron Energy Solutions² installed a microgrid at Santa Rita Jail in Dublin, California, as part of the Department of Energy’s Office of the Electricity Delivery and Energy Reliability’s Renewable and distributed Systems integration program. The smart microgrid incorporated fuel cells capable of producing heat and power energy, solar photovoltaic system, wind turbine generators, battery energy

² Chevron Energy Solutions has been acquired by OpTerra Energy Services.

storage, and backup diesel generators. The incorporation of the microgrid reduced the jail's peak power load by 95 percent and reduced energy consumption during peak hours by 98 percent. The prison also annually saved \$110,000 on electricity bills (National Energy Technology Laboratory, 2014).

In terms of freight efficiency, the benefit of microgrids can be applied to hybrid and electric trucks. "A recent study found that the expansion of high-efficiency trucks can generate \$24 billion in net economic benefits and grow 124,000 jobs in the United States by 2030" (California Air Resources Board, 2010). In addition, this will have reduced long-term operating costs. Hybrid and battery-electric trucks have expanded body or chassis combinations that allow for greater freight efficiency, and the use of microgrids at distribution nodes can direct power to charge trucks (California Air Resources Board, 2010).

Furthermore, microgrids can support the industry's implementation of ITS in trucking to increase highway capacity, and utilization of cruise control in vehicles to allow safer platooning at closer distances and at higher speeds (American Highway Users Alliance, 2015). Already, "trucks with active emergency braking and blind spot warning systems are preventing rear-end and side swipe collisions that traditionally cause hundreds, if not thousands, of daily traffic jams" (American Highway Users Alliance, 2015). Microgrids can support these technological solutions and improve freight efficiency by providing power for these smart vehicles.

Other technological innovations in freight transportation that may need reliable resilient power provided by microgrids include: electrical toll collection, which greatly speeds traffic through toll booths, ramp metering, traffic signal coordination, automatic transmission shifting in trucks using advanced maps and real-time data to reduce fuel consumption and increase safety, and congestion pricing based on ITS technologies (American Highway Users Alliance, 2015).

Thus, with the continuous technological evolution in freight and demand for higher performances, it makes sense to develop an energy management team to meet operation efficiency. An energy management team, similar to the Port of Los Angeles' Energy Team, can organize and coordinate freight objectives and needs, operate controls, measures, and procedures to reduce energy consumption, and increase freight efficiency (Parise, Parise, Martirano, Chavdarian, Su, and Ferrante, 2016).

Expected Costs

"A supply of reasonably priced and reliable power is the number one consideration for large scale electrification efforts at ports" (Sain, 2014). According to the Port of Long Beach fiscal report, it allocated \$750,000 for Energy Island Initiative planning activities (POLB, 2015). Since the Energy Island Initiative is specific to the Port of Long Beach and is still in its initial planning phase, expected costs for the initiative are unknown. However, as the Port moves forward with its Initiative Planning phase, specific milestones and funding will be clearer with the implementation of the initiative's three phases, shown below:



The Program Overview states that the Port anticipates Phase 1 of the program to be implemented over the next one or two years, and Phase 2 will be approximately three years. The Port of Long Beach plans on completing Phase 3 and overall implementation of the project in approximately ten years (Port of Long Beach, 2015).

Elsewhere, in a cooperative initiative between the Halifax Port Authority, the Government of Canada, and the Province of Nova Scotia, the Port of Halifax plans to provide shore power for parked vessels in 2014. Part of that cooperative initiative calls for the implementation of microgrids as a baseline to apportion the power needed for the marine terminal. This was a \$10 million cooperative initiative (Sain, 2014).

In an interview in March 2015, Gil C. Quiniones, the President and CEO of the New York Power Authority (NYPA) and Chairman of the Electric Power Research Institute announced NYPA’s plans to utilize microgrids in their energy efficiency plans. Through the NY Prize initiative, New York plan to fund up to \$100,000 for up to 25 microgrid feasibility studies, and \$1 million for up to ten detailed designs, and \$7 million for construction of up to five projects (Quiniones, personal communication, 2016).

Role of the Public Sector

According to Sara C. Bronin, professor of law and program director for the Center for Energy and Environmental Law at the University of Connecticut, “In nearly every state, the legal and regulatory challenges to implementing microgrids are by far the biggest hurdle” (Magill, 2013). Therefore, the Port of Long Beach’s Energy Island concept requires full collaboration with tenants, city agencies, departments, environmental groups, labor organizations, local colleges and universities, and community members.

Other lessons can be drawn from the experience of microgrids in other locations. According to the New York State Energy Research and Development Authority (2010), microgrids are not defined in the New York State law governing the electric and steam industries. Therefore, in their implementation, ownership and service models are not illegal. However, microgrid features will vary depending on the technologies deployed, whether the system is located on private or public property, or whether serving residential or unaffiliated customers, and size of the distribution area (New York State Energy Research & Development Authority, 2010).

However, according to Quiniones (2016), the New York State Public Service Commission’s Reforming the Energy Vision (REV) is “transforming how customer energy projects, including microgrids, participate in NY energy markets.” This means that the New York State Public Service Commission has implemented not only policy regulations since 2010, but also regulations that add incentives to building microgrids. New York recognized the benefits from

microgrids' automated control technologies that enable local energy sources to seamlessly operate as part of a main grid or independently from it (Quiniones, personal communication, 2016). With regulations that will create a market for microgrids, New York is easing the public sector's burden to supply energy by making it possible for small businesses to build microgrids and generate revenue, thereby producing jobs and jump starting the local economy.

Romankiewicz, Qu, Marnay, and Zhou (2013) recommend policymakers "develop standards and processes for interconnection of microgrids" as soon as possible. This will require policymakers to proactively plan for short-term reviews, but also be able to evaluate the large scale impacts of a microgrid. Also, to increase incentives to monetize microgrids, policymakers should "consider modifications to electricity rate design" (Romankiewicz, Qu, Marnay, and Zhou, 2013). This means looking at pricing and demand charges on both the purchase and sale side of the microgrid transaction. Furthermore, the public sector must take stock of current incentive policies and analyze the barriers and opportunities to implementing microgrids (Romankiewicz, Qu, Marnay, and Zhou, 2013). This will allow the public sector to better enable the use of microgrids in various industries and communities.

Implementation Challenges

A major challenge involved in the implementation of microgrids is assessing how the cost of microgrid technologies will change over time, and how vulnerable such facilities might be to changing fuel and energy grid costs. Onsite energy storage also needs to be assessed along with dependence on fuel supplies and deliveries. "While technology advancements are facilitating business and utility microgrid implementations, the integration of distributed generation into a utility system is not a trivial matter and facility and utility experts need to proactively get involved to address emerging issues" (Masiello, 2013).

According to Parise, Parise, Martirano, Chavdarian, Su, and Ferrante (2016), ports have the unique challenge of limited potential onsite renewable power generation. This is due to the fact that land area is comprised of marine terminals dedicated to maritime goods movement operations.

The most common technical barriers to microgrids include technology components, dual-mode switching from main grid connection to "island," power quality control, and protection issues. Also, regulatory barriers exist in interconnection rules with the main grid and the bi-directional power flow between the microgrid and the main grid. There are unfair cost distributions between entities utilizing microgrids and with shared local and regional power trade. So, despite the "push to build microgrids," the "laws and rules governing the sale and transmission of power" are too new to fully regulate the implementation of microgrids (Magill, 2013). According to Romankiewicz, Qu, Marnay, and Zhou (2013), "there is not a strong enough policy signal for widespread deployment of microgrids." So an international standard does not exist nor a general implementation plan for microgrids.

The main financial barrier, however, lies in the high investment needed to implement microgrids and replacement costs of the microgrid. Furthermore, there are stakeholder barriers with conflicting self-interests and expertise in managing microgrid operations (Soshinskaya, Graus, Guerrero, Vasquez, 2014).

Further challenges implementing microgrids in ports and distribution nodes reside in the complexity of related design requirements and operational specifications so that power systems may be efficiently built, operated, and maintained. Because microgrids are fairly new technology, the plan must allow for design revisions and experimental operational data as this will allow operators to identify and isolate issues in the complex system, adopt additional power sources, and efficiently configure power distribution. To fully leverage this data, however, requires an energy management team to measure, analyze, review, and coordinate projects to reduce energy consumptions and address inefficiencies (Parise, Parise, Martirano, Chavdarian, Su, and Ferrante, 2016).

Measuring Success

The success of the Energy Island Initiative specifically for the Port of Long Beach hinges on whether the program accomplishes its five goals:

1. “Advance green power, both generated and purchased;
2. Use distributed self-generation with microgrid connectivity to provide energy security and sustainability;
3. Provide cost-effective, advanced fueling opportunities to port operators;
4. Improve energy and energy-related operational efficiencies; and
5. Attract new businesses, create new jobs, and produce higher revenues or cost savings” (Port of Long Beach, 2015).

In its Initiative Planning phase, the Port of Long Beach through its Energy Technology Advancement Program (ETAP) is seeking a funding partnership with Port tenants with emerging energy technology that may be applied to the seaport industry. The Port is particularly looking for technologies that will increase efficiency in port operations, improve energy reliability, and potential health and environmental benefits of reduced emissions (Port of Long Beach, 2015). This, along with the Port’s preliminary research on planning, studies, and pilot projects (e.g. large wind feasibility, port wide power-demand assessment, LNG siting, cost and demand, and distributed generation and microgrid feasibility among others) will determine whether the Port can successfully transition all of the Port’s power costs for terminal operations to renewable power sources, energy storages, and self-generation systems and controls.

To achieve this full transition, an energy management team is crucial to determine the success of fully implementing microgrids and to study its net effect on port operations and freight.

The successful transition may mean increased automation in port operations, and thus freight efficiency at distribution nodes. Also, leveraging the ports’ electrical power could result in increased use of hybrid or electrical trucks as the distribution node may also serve as charging station and incentivize the use of hybrid or electrical trucks. It could also encourage greater ITS implementation, leading to the automation and implementation of information-sharing technology that will make platooning more feasible.

Energy Island

Benefits	Reduce environmental impact while providing high energy efficiency, reliability, and quality of the electricity service; self-generation allows hubs to “island” power source or to operate in isolation of main grid or supply power in event of natural or man-made disasters to community’s critical operations, cost-effective, attract new business, promote good jobs and advanced technologies, customer retention
Costs	For 2016, POLB will allocate \$750,000 for Energy Island Initiative planning activities; this includes research and pilot projects of advance marine terminal energy technologies
Public role	Collaboration with tenants, agencies, city departments, environmental groups, labor organizations, local colleges and universities, and community members; funding opportunities, energy evaluation, and incentive programs; regulatory changes to provide greater incentive for microgrids
Challenges	Limitation of potential onsite renewable power generation since land area is comprised of marine terminals dedicated to maritime goods movement operations; regulatory constraints (i.e. submeters not allowed) and lack of directives from energy management impede the necessary innovation to meet the new environmental and energy goals – need it for electric energy utilization; and existing rules and laws in area of cost for electrical power consumption and distribution of cost; high investment costs

Theme 2: Improved Truck Access At Nodes

It is no secret that California is home to some of the most congested roadways in the nation. The American Transportation Research Institute (ATRI) and the Federal Highway Administration (FHWA, 2011) recently released a report on the top 250 worst bottlenecks in the country. Results from that study found that California was home to 15 of the 250 worst bottlenecks across the country. All 15 of those bottlenecks were among the top 160 worst bottlenecks, with seven in the top 100 and 13 in the top 150. In another bottleneck study released by the American Highway Users Alliance in 2015, California had 14 out of 50 of the worst bottlenecks in the nation. Although the two reports used different methodologies, both issued findings that pointed to the clear need for improved operational efficiencies across California’s supply chain. Truck congestion and bottlenecks lead to idling trucks that generate more toxic emissions, slowdowns in commerce, and congestion that impacts other modes of transportation—thus impacting quality of life for all Californians. To address truck congestion, this white paper recommends further investigation of a series of strategies to promote operational efficiencies at critical truck nodes. The first of those strategies is truck platooning.

Truck Platooning

In addition to a need for improved velocity and efficiency within the transportation sector, environmental impact and cost reduction should also be major priorities. Transportation is

responsible for 28 percent of the nation’s carbon emissions, second only to power plants at 31 percent (Davies, 2015). By nearly any measure, trucks play a significant role in contributing greenhouse gas, consuming more than 25 percent of the fuel burned annually. Fuel also accounts for 39% of overhead costs for the trucking industry with the average truck burning 20,500 gallons of fuel per year. New technologies and policies need to be embraced in order to improve fuel efficiency in trucks. An increase in fuel efficiency would allow for both savings in fuel costs, and reduction of emissions. Efforts have been made to increase the aerodynamics of truck fleets by utilizing fairings and other retrofitted accessories, but “there’s so many electronics on there,” Robinson [senior vice president of maintenance at flatbed carrier Melton Truck Lines Inc., Tulsa, Oklahoma] said. “You have to have a laptop with all the different software to check the engine, check the transmission, check the trucks, and so on and so forth (Clevenger, 2012).” This means that new ways to optimize fuel efficiency must be found, since there is push back against existing solutions.

Description

One of the proposed methods to increase efficiency in the trucking industry is called truck platooning. Truck platooning is the process of tethering two or more trucks together with a wireless signal. “At the heart of platooning is a wireless electronic communications system, also connected to the internet, which tells the second truck when the first truck driver has braked. The second truck brakes almost instantaneously without driver intervention. In essence, both trucks brake at the same time (Kahaner, n.d.)” The front truck controls speed and braking for the whole chain of trucks, while the following vehicles remain engaged in steering. All trucks in the “train” are equipped with dash cameras and monitors that keep track of the road in front of the lead truck, as well as the road behind the rear truck. Though the concept has been touted for years as a remedy to high fuel costs and traffic congestion, it has not been until recently that technological advances have actually made it possible. With that said, there are still technological hurdles that need to be overcome before this practice can be used on a widespread basis. “It is envisioned that if a convoy needs to be joined, it would probably be a matter of driving to an entry ramp where the car would then poll vehicles on the motorway as it looks for a compatible convoy to mesh with for a required journey destination. (Fleming, 2012) It is still a nascent technology that is being tested in limited capacity trials in Europe as well as in the United States.

Expected Benefits

Truck platooning impacts freight efficiency in multiple ways. When multiple vehicles are tethered together and heading in the same direction they can travel at higher speeds because drivers do not have to worry about predicting the moves of the other trucks. Furthermore, there are significant gains in aerodynamics as a result of truck platooning. There are essentially two kinds of drag: friction and pressure. Friction drag is the contact of air and the object moving through it. Pressure drag has to do with the low pressure created as the air moves around the object. In truck platooning, the lead truck eliminates a significant portion of the friction drag for the following truck(s). The following truck(s) help minimize the impact of pressure drag for the lead truck. This reduction in drag has been linked to up to 16% in fuel savings, reducing fuel costs and stops for fuel, which improves efficiency and shortens trips. The decreased fuel usage

also reduces the environmental impact of shipping, as less fuel is used and trucks give off fewer emissions when travelling at higher speeds.

Discussions of truck platooning have become increasingly ubiquitous as more research and related technology demonstrations reflect benefits in both shipping velocity and fuel efficiency. One such demonstration was carried out by Auburn University, in partnership with Peloton Technologies, a California based firm. The study was conducted at Auburn's GPS and Vehicle Dynamics Laboratory with the intent of testing a system of up to three trucks to convoy, tethered through a wireless driver assistive truck platooning system (DATP). The study found an estimated 7.5 percent increase in fuel efficiency, with the rear trucks using 10 percent less fuel, and the lead truck saving 5 percent (Auburn University, 2015). This result was in part due to achieving improved aerodynamics by decreasing the space between vehicles on the road, but also because trucks in the convoy can achieve uniform ideal speeds that give all participating trucks the benefit of added efficiency and reduced driving time (American Transportation Research Institute, 2015). Peloton estimates that if this model were to be applied to the entire trucking industry, companies could stand to save a combined \$6 billion worth of diesel per year (Peloton, 2016). When 40 percent of shipping fleets operating costs are in diesel, and the trucking industry accounts for ten percent of the nation's overall fossil fuel consumption and carbon dioxide emissions, the importance of increasing fuel efficiency is paramount.

In addition to the study that was carried out by Auburn University, Caltrans is carrying out a platooning test trial in conjunction with the UC Berkeley Partners for Advanced Transportation Technology (PATH) program. This technology demonstration will likely commence later this year. The test area will be centered in the Port of Long Beach/Port of Los Angeles area, and extend up to State Route 60. This new battery of trials intends to use pre-existing advances in platooning, and build off of them. One goal is develop and streamline the in-vehicle system that will control the tethering and speed regulation processes, as well the ability to tether up to three vehicles at a time. The other primary objective is to test and improve systems that will allow platoons to interact with traffic in a safe and consistent way, through maneuvers such as lane changing, merging, as well as joining and leaving a platoon mid-trip. The study also seeks to get driver feedback with regard to the preferred distances between platooning vehicles, and subsequently calculate the fuel savings for those distances (G. Larson, personal communication, March 1, 2016)

Overall, truck platooning research has been conducted regarding how systems like Peloton's can be deployed effectively on an industry-wide scale. Fleets and drivers who average trips of 500 miles or more have the most to gain from using DATP, while small fleets would still be able to reap benefits by using a "back office" system like Peloton's Network Operations Center to find other trucks to platoon with, potentially from other fleets. This type of model uses a central network and center for clients to log into, and get in contact with other users in order to collaborate on routes and create platoons. Small firms would be able to expect paying off their initial investment (hardware, software, installation) within ten months, whereas larger fleets could see payback in projected 18 months. The Auburn-Peloton study found that platooning systems at worst would only perpetuate the current levels of congestion, only having the ability to improve congestion. The report also found that, if market penetration were to reach 60%, there could be marked increases in efficiency and decreased traffic congestion across the

board, even for those not directly using platooning software. As increased trials produce greater amounts of quantifiable data, truck platooning will become a much more feasible option, and more palatable to both private and public decision makers.

The Auburn-Peloton technology demonstration and related analysis was funded by the Federal Highway Administration. A related business-case analysis on the demonstration was performed by the American Transportation Research Institute (ATRI), which addressed the users, sectors, and business models that are most likely to adopt the platooning approach. ATRI conducted an industry survey that solicited both carrier and driver cost and benefit expectations. Due to limited industry knowledge of platooning at this time, the survey should be viewed as an initial investigation that may be refined as stakeholders gain better understanding through demonstrations and pilot tests. Nevertheless, insights can be found from these early results. Findings from the survey include:

- The platooning concept is most advantageous when travel speeds are higher (because drag isn't a significant factor at lower speeds), truck trips are longer (i.e., benefits accrue over time/distance), and the likelihood of encountering similar trucks installed with DATP technology is high.
- Industry data derived from surveys and technical reports (e.g. ATA Trucking Trends 2013) indicate that over-the-road operations, with an emphasis on "truckload" (TL) and line-haul "less-than-truckload" (LTL) sectors would experience the highest likelihood of encountering the desired attributes. In particular, truckload operations often have pre-determined routes or corridors between large freight generators (e.g. business parks, manufacturing centers, warehouses, retail establishments).
- Truck routing: based on survey responses, 75% of the time the truck routing was determined in advance of the trip. Although the survey data shows that a meaningful number of these trips experienced unexpected route changes, the ability to potentially concentrate DATP-installed trucks through advance planning may increase industry interest, at least by those TL firms that have multiple DATP trucks and dedicated routes between freight generators.
- The largest percentage of TL trip mileage occurs on highways and interstates, which immediately improves the attractiveness of platooning to this sector. Based on the survey, 71% of the TL mileage was generated on limited access interstates and highways (ATA Technology and Maintenance Council, 2015)

In addition to domestic platooning research, there are also existing models of truck platooning tests that have been tested internationally, and which are being incorporated into developing systems for the U.S. The Safe Road Trains for the Environment (Sartre) program, founded by the European Commission under the Framework 7 program, emphasizes an approach that balances environmental impact, traffic safety issues, and congestion (Sartre, n.d.). It also investigates other possibilities of DATP, such as incorporating regular passenger vehicles into platoons, and of potentially allowing for platoons serving almost as mobile car pool lanes. This illustrates that not only are the regions in which platooning is being tested and refined diverse, but the approaches also vary in terms of objectives and scope.

The increasing volume of freight passing through transportation hubs and along transportation corridors over the past 10 years had created bottlenecks that are increasingly severe. With more material coming in, there need to be substantial changes to the way freight is moved in order to mitigate these bottlenecks. The trucking industry is essential to this effort, because without the ability to move goods more efficiently, the whole supply chain becomes compromised. As it stands, trucking corridors are highly vulnerable to traffic fluctuation, accidents, and infrastructure problems (either failures or construction projects).

This vulnerability is what creates a necessity for increased investment in ITS. “The implications of “smart mobility” and “connectivity” are therefore just as important for managers overseeing the flow of goods across oceans and rail lines as they are for the truck driver hoping to save half-an-hour of on-duty time by avoiding a crowded weigh station” (Cassidy, 2014). With more real time data coming from vehicles on the road, truck nodes such as ports and distribution centers will be able to anticipate and account for challenges while processing freight more efficiently and reflexively. Truck platooning may play a role in attaining this goal because it initiates the process of incorporating intelligent transport systems into the cab. For a larger quantity of up-to-date, descriptive data to be attainable, a mosaic of systems deployed simultaneously is required. Ideally, trucks would platoon through corridors to nodes, where they would be processed by peel-off systems, and would know which containers they would pick up well in advance due to coordination with virtual container yards. “As trucks travel interstate highways, onboard sensors are collecting, sending, and receiving information, with the lion’s share going to and coming from a fleet management system. But as technology advances, the truck is being knit into a broader, more open network” (Cassidy, 2014). Though each idea would improve operational efficiency in its own right, without combining multiple strategies the potential of each is diminished. Looking at the bigger picture, interconnectivity will be the new trend in transportation, meaning that what is happening at the port will affect movement on the highway, and vice versa. Therefore, truck platooning might be a corridor-focused practice, but its effects will influence the entire supply chain.

Testing of automated platooning has shown significant fuel economy benefits due to close-headway following enabled by the V2V communications link. A 2013 test of an early truck platooning implementation showed improvements on the order of 4.5% for the lead truck and 10% for the following truck, when traveling at (100 kph) 64 mph at (11m) 33 ft spacing.

In 2014, DOE’s National Renewable Energy Laboratory (NREL) conducted tests of platooning systems implemented by Peloton Technology. The SAE J1321 Type II Fuel Consumption Test Procedure was managed by NREL, using vehicles loaded at 65,000 lbs running at up to 70 mph. 20-75 foot inter-vehicle gaps were evaluated. The testing documented up to 5.3% fuel savings for the lead truck and up to 9.7% fuel savings for the trailing truck.

The Dutch research group TNO published an extensive study on two-truck platooning in early 2015. The authors note that the “political and economic climate is positive for a broad deployment of platooning as initial legislation amendments are proposed to allow testing and experimentation on Dutch roads” (Janssen, Zwijnenberg, Blankers, Kruijff, 2015). To maximize benefits, they introduce the concept of a Platooning Service Provider (PSP) to support ad hoc

formation of platoons. The PSP would help platoon partners find one another on the road, as well as certify participants:

“For on-the-fly platooning it is not necessary to know exactly where your platoon partner is going. However, for reasons of safety and trusting your platooning partner – especially if you are the driver of the Following Vehicle – you might want to know where your platoon partner is going, whether the leading driver took the required rests, and whether the Leading Vehicle is in good mechanical condition and is properly maintained. PSPs can establish quality schemes such that truck drivers can have the confidence that on-the-fly platoons are only formed with ‘trusted partners’. The PSPs also deal with administrative duties from the platooning activities, arrange insurances, and make sure that benefits of platooning are distributed fairly among the platooning partners” (Janssen, Zwijnenberg, Blankers, Kruijff, 2015).

They note that platooning “will allow a more optimal use of the available road capacity considering a normal situation with 2 trucks driving 80 km/h with a 2 seconds gap. With a truck length of 18.75 metres this results in a claim of 82 metre road, excluding the gaps in front of the first truck and behind the following truck. Using platooning, a 0.3 second gap would decrease the length of those two trucks with 46% to 44 metres. With platooning the existing roads will suffice longer without the need for additional lanes or roads, especially on road segments with a high percentage of trucks, so road investment projects could be delayed” (Janssen, Zwijnenberg, Blankers, Kruijff, 2015).

The TNO team provided a useful summary of overall benefits via this chart:

Expected Costs

Due to the speculative nature of truck platooning’s development, it is all but impossible to give stable cost projections as much of the technology required is still in development, and there are different models being tested. There have been estimates of around “€ 1,500 per driver, based on experiences with LZV and SARTRE 14, including periodic re-examination,” but those can’t be

confirmed until technological concerns are settled (Janssen, 2015). Furthermore, depending on which model of truck platooning is employed, costs may fluctuate. Additionally, ““little attention has been paid to optimally coordinating the formation and dissolution of platoons to minimize total fuel use as many vehicles move throughout a road network” (Larsson, Sennton, and Larson, n.d.). This could pose major safety risks to both commercial and casual drivers on the road.

Role of the Public Sector

Just as the costs are largely unknown, there are some major blind spots regarding what must be done on a state and federal level to ensure that this idea can be implemented. Regulations and laws wouldn't only be necessary for the feasibility of enacting a platooning regime, but also to allow for substantially “more efficiency... if we could convince the government to give drivers of autonomous vehicles a little more legal time on the road. (Considering the fact that our current hours of service regulations are still locked in unending cycles of litigation, I wouldn't hold my breath on that one)” (Lockridge, 2015). Regulations regarding distance between vehicles, cruise control, and sharing of information would need to be standardized across state borders.. Furthermore, there may need to be physical changes in infrastructure to allow for elongated chains of trucks travelling in unison (Janssen, 2015). Until the technology is solidified, tested, and there are tangible proposals on the table, it will be difficult to predict what must be done by the public sector.

Implementation Challenges

There are numerous barriers to implementation that impact the feasibility of truck platooning. Unpredictable road conditions make the prospect of large trucks travelling at close proximity to one another a dangerous proposition, meaning that “automated vehicles will have to co-exist with manually driven vehicles as well as other road users (pedestrians, cyclists, etc.) [...]The literature reviewed indicates that this topic is somewhat neglected. (Azra, Englund, and Wedlun, 2013).” Fleet heterogeneity could also prove to be problematic, given that companies often have trucks of varying makes and ages in their fleets, some of which would be compatible and some that would not. Unforeseen maintenance costs would act as a deterrent to businesses implementing this strategy, especially without an established precedent or methodology. However, unpredictable road conditions, fleet heterogeneity, and unforeseen maintenance costs are self-evident challenges that legacy trucking firms also face. Viewed in this way those challenges should not be viewed as unique to only next generation platooning technology implementation. Alternatively, computational complexity does pose major concerns as to how wireless systems could account for potentially every truck in the United States being connected to their network. Yet, here again, this barrier to implementation should be viewed in the proper context—given that not all trucks are going to opt-in simultaneously. Such platooning networks will grow incrementally in a manner similar to the gradual buildout of wireless phone networks. That said, failures in wireless tethering systems could prove catastrophic in adverse weather or road conditions and safeguards must be developed.

Virtual Container Yards

Densely populated freight nodes (e.g., LA-Long Beach, San Francisco Bay Area and New York-New Jersey regions) face trade imbalances between imports and exports which lead to significant increases in container traffic. It also worsens empty container management issues which include inefficient empty truck shipments to and from ports. (Theofani & Boile, 2007) Primarily, return trips carrying empty containers cause unnecessary congestion at terminals which not only affect overall flow efficiency, but increase CO2 emissions caused by idling (see figure below).

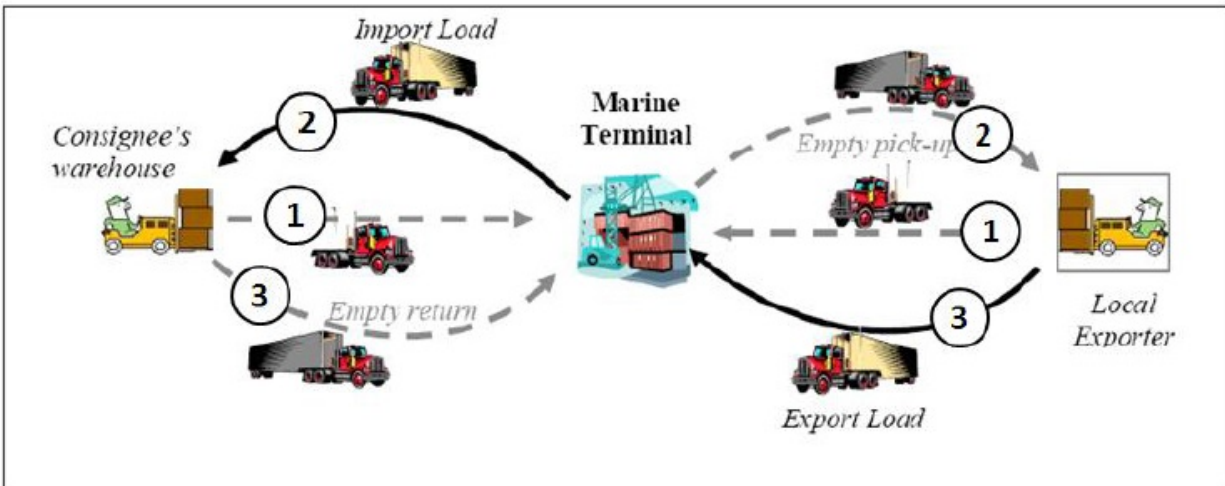

(Islam, Arthanari, Olsen, 2010)

Virtual Container Yards (VCY) are Internet-based systems that collect real-time information on the locations of empty containers to broker potential exchanges between participating parties without the need of a physical container yard. The key purposes of VCYs include:

- Posting critical information on cargo and containers locations statuses;
- Facilitate communication between participating businesses;
- Permit and document exchanges without moving containers to nodes; and
- Assist businesses in container logistic decision making (Hanh, 2003).

In essence, this would significantly alleviate congestion issues in addition to saving emissions and fuel consumption. Additionally, a private third-party would develop and facilitate potential transactions, diverting any implementation costs from the public sector. An example of the streamlined process is depicted below:

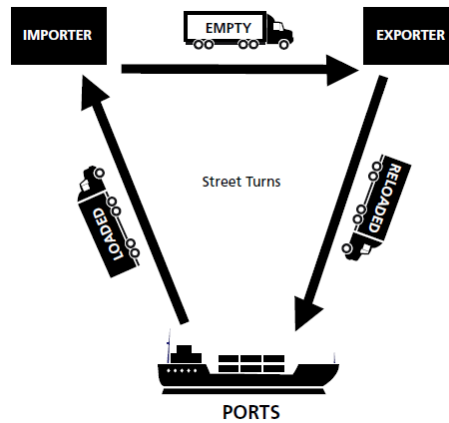

(Port of Long Beach, n.d.)

Expected Benefits

Implementing VCYS benefit both freight nodes and participating businesses by reducing costs through gained efficient operations. Specific quantifiable benefits for freight nodes vary depending on the operational constraints of each node. For instance, the New York Metropolitan Committee determined that VCYS would eliminate approximately 1,100 vehicle trips to the New York and New Jersey ports per day. The burden would be on major economic centers to weigh benefits relative to their respective operations. However, freight nodes in general will avoid “additional gate transaction costs, grounding, storage and equipment costs,” and save carriers about \$200 per re-use transaction (Mongelluzzo, 2006).

From the participating business’ perspective, efficiencies created will translate into savings from reduced fuel costs and decreased time spent hauling empty containers. Both freight nodes and participants will benefit from low-start up and implementation costs since the third-party developer will be responsible for launching and maintaining VCYS software. Therefore, entities will only need to pay relatively nominal fees for software usage. VCYS implementation also aids reducing CO2 emissions by greatly reducing truck congestion and idling at major terminals (Gladstein, Neandross & Associate, 2013). The success of VCYS initiatives can only be made possible by company cooperation. Increased cooperation will exponentially amplify aforementioned benefits that affect nearly every part of the supply chain. Therefore, pushing for VCYS implementation will only strengthen overall economic vitality.

Expected Costs

Cost considerations boil down to capital investments, annual operation costs, and annual maintenance costs. However, it is assumed that vendors will entirely cover maintenance and operating costs since they are the ones developing the software. Therefore, capital investments become the only cost concern for implementation. For instance, the following hypothetical capital investment alternatives were presented in a study investigating the feasibility of establishing VCYS in the New York-New Jersey region:

- The Port authority paying a percentage of the capital and the vendor pays the rest;
- The vendor paying the capital costs excluding installation/access fee; and
- The vendor paying the total capital costs, including the installation/access fee (Theofanis & Boile, 2007).

User costs will depend on the vendor's service. For an example of pricing and services, see eModal's company website: <http://welcome.emodal.com>.

There are also potential weaknesses to implementation that would do little to reduce current costs environmentally. First, congestion could move from freight nodes to VCY sites, therefore making overall emission reductions insignificant. Also, if current growth projections of VCY implementation hold, then respective initiatives will have negligible impacts on congestion, emissions, and fuel savings overall (Gladstein, Neandross & Associate, 2013).

Role of the Public Sector

Industry-wide VCY acceptance is, in essence, a technological paradigm shift. Moreover, the technology depends on resource sharing mentality, which was already proven to be an issue since only 2% of container trips uses VCY services where available. (Gladstein, Neandros and Associates, 2013). Therefore, successful use of virtual container yards depends on addressing the following: 1) determining the main factors behind overall reluctance to participate in the virtual container yards and 2) spearheading collaboration and awareness efforts by highlighting the obvious economic benefits brought upon by increased port efficiencies.

Most failures can (at least) partly be explained through "weak project governance and limited partner participation" (Theofanis & Boile, 2007). Therefore, the role of the public sector includes engaging and accurately identifying general third-party reluctances that hinder implementation. Based on that, public sector entities should then develop a clear proposal that details compelling system governance that highlights the potential benefits of VCYs to economic vitality and how those benefits outweigh third-party concerns.

Implementation Challenges

Virtual Container Yard software was launched nine years ago but proved ineffective due to a lack of demand for the service. Diminished demand could be related to implementation challenges with practical considerations. For instance, Le Dam Hanh, USC Department of Civil and Environmental Engineering, points out:

"... (to the extent that existing, or yet to be developed, Internet-based information systems can be successfully applied) successful applications of Web-based information depends on the willingness of all participants to share business information on a timely basis, and this particularly requires cooperation among ocean carriers. Without satisfying these basic conditions, the role of these systems in rationalizing empty container movements in the SCAG [Southern California Association of Governments] region would be limited."

Other considerations may include:

- "ocean carrier free time and per diem provisions;"
- "inspections and liability for damage on interchanged containers; [and]"

- “ocean carrier incentives for empty return versus export loading...” (The Tioga Group et al., 2009).

Finding export loads for inbound containers emptied at inland distribution centers may also prove difficult in heavy trade environments areas such as Southern California and New York-New Jersey where imports outnumber exports two or three to one (Mongelluzzo, 2006).

Overall, successful implementation depends on involvement from all key players within the system trying to be implemented. This emphasizes the necessity for understanding and responding to the inevitably varied needs and expectations of those players. However, renewed interest in the concept reemerged within recent years as evidenced by the development and growth of service provider [eModal](#). As aforementioned, only 2% of container trips use Virtual Container Yard services (where available) which suggests the demand problem persists (Gladstein, Neandros and Associates, 2013). That said, a 2% usage rate for Virtual Container Yard services should not be interpreted as an overall reluctance between companies to engage in cooperative arrangements but rather a slow evolution from traditional partnerships to next-generation technology driven partnerships. Intermodalism itself is based on cooperative arrangements and equipment interchange – these arrangements have only increased and become more dynamic over time. The lack of VCY use alone does not diminish these intermodal relationships or demonstrate a reluctance to engage in them; rather it is likely a more traditional market-based rationale. Regardless, significant growth opportunities exist for virtual containers yards and the burden is on the public sector to balance the costs and incentives to all commercial players and develop a compelling value proposition that includes and details the feasibility of implementation (including considerations any impeding information, institutional, and business-related barriers) (Theofanis & Boile, 2007).

Design-based Guidelines

The White Paper research included a review of literature ranging from private-sector documents to Midwest and coastal state and city DOT plans that focus on design-based guidelines for truck access efficiency at nodes along the supply chain. Design-based guidelines, in this case, refer to the physical design elements that either aid or impede how trucks flow through nodes (e.g., ports, docks, airports, distribution centers). Portland’s Office of Transportation adopted its *Designing for Truck Movements and Other Large Vehicles in Portland* plan in 2008 which offered common examples of what these design guidelines may look like. For instance, when designing for truck traffic in any facility, designers need to adopt a “design for” mentality which means considering truck types and their movement capabilities. If a designer knows what truck types will be passing through an access point, they can evaluate track maneuvers of specific trucks using resources such as AASHTO turning templates of software such as AutoTURN (see Figure 1):

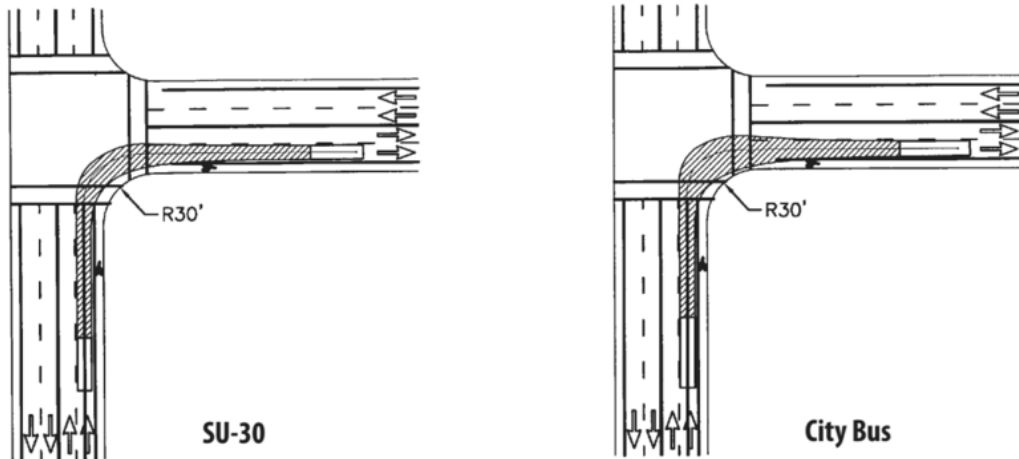

(Portland Office of Transportation, 2008)

NOVA Technology, a producer of loading dock equipment, published a document that offered design guidelines for safe and efficient docks. Like Portland’s document, NOVA presents practical guidelines for issues that identify best with design-based solutions. For instance, planning on-site traffic patterns serves towards efficient truck maneuverability within a dock. Patterns should be designed around buildings so that truck drivers are on the inside of each turn, giving them best control of the truck. Roads within a dock should also be separated so employee traffic does not interfere with truck movement (see Figure 2).

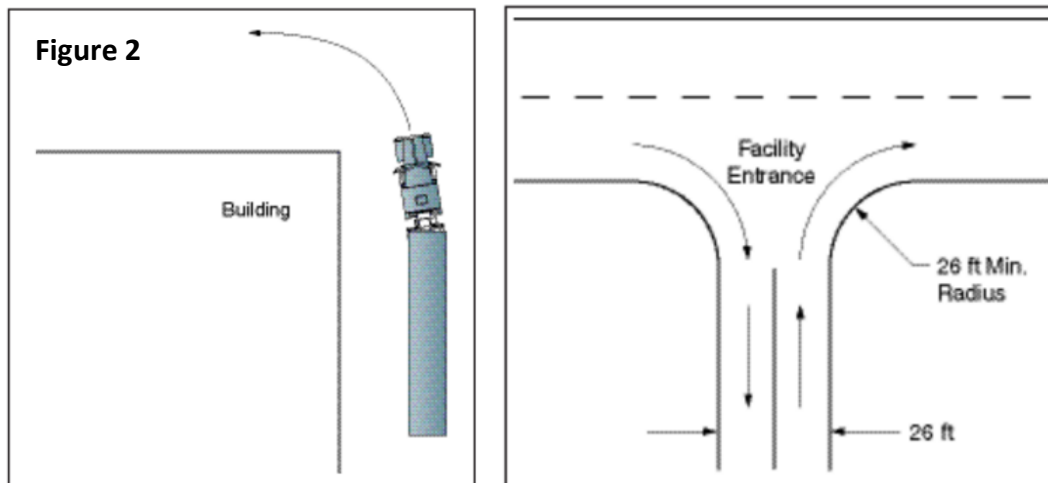

(NOVA Technology, 2013)

Other examples of common design-based guidelines for truck movement include (Washington State DOT, 2014):

- Designating truck freight routes for hazardous materials or oversize/overweight truck loads

- Managing curbside truck parking spaces/load zones
- Incentivize importers for adopting night delivery practices
- Providing truck parking and loading zones that match truck trip demand connecting to business districts and urban corridors

Note that while the examples from the Portland and NOVA documents address intersections and docks respectively, those guidelines provide transferable insight into possible solutions at other nodes such as ports or distribution centers. Moreover, the aforementioned examples help define design-based guidelines in context with issues covered within this white paper.

Truck access issues extend beyond the design elements of a specific node. Often times, access issues occur in routes connecting to the node within metropolitan areas. To demonstrate, the Chicago Metropolitan Agency for Planning (CMAP) points out:

“Compared to the 631 million tons moving by rail in the region, CMAP estimates that approximately 1.472 billion tons of freight was moved by truck in 2007 — more than 2.3 times the rail volume, and approximately 67 percent of the annual regional freight tonnage. Of this total, approximately 36 percent of all freight movements were through-traffic” (Chicago Metropolitan Planning Agency, 2010).

Furthermore, a 2013 study conducted by DKS Associates in 2013 focused on the outbound movement of goods from Westside C&E manufacturers to Portland International Airport’s (PDX) consolidation area. The study concluded that PDX is actually a critical freight hub along the company’s supply chain (see Figure 3) since most C&E freight moves out of PDX via truck. The study also found it is most efficient to truck goods to airports that have stronger links to overseas destinations. More importantly, the reliability of Portland’s roadway system (including rural roads with known deficiencies) is essential to C&E’s goods movement (DKS Associates, 2013).

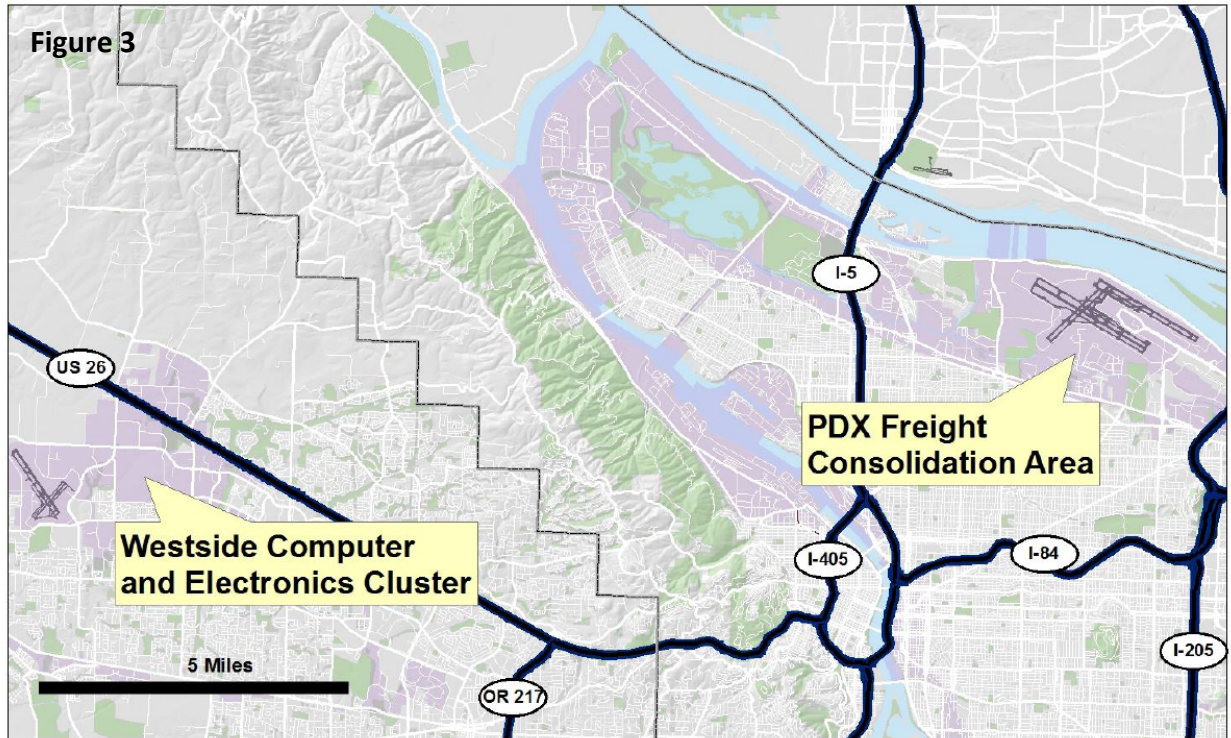

CMAP’s and DKS’s cases show the prominence of trucks within any given supply chain. Therefore, inefficiencies in truck movement have widespread consequences for the economic vitality of businesses and the communities they serve. While, several of these inefficiencies can be traced to truck access nodes, the interconnected nature of any supply chain cannot be ignored. Therefore, developing effective guidelines requires a systematic evaluation process. Specifically, answering questions such as: what inefficiencies impact truck access the most? Where are they occurring? How should projects addressing those issues be prioritized relative to other projects, and how much will the improvement process cost? Seattle’s Freight Access Plan exemplifies a structured approach that follows this line of questioning (see Exhibit 1):

Exhibit 1

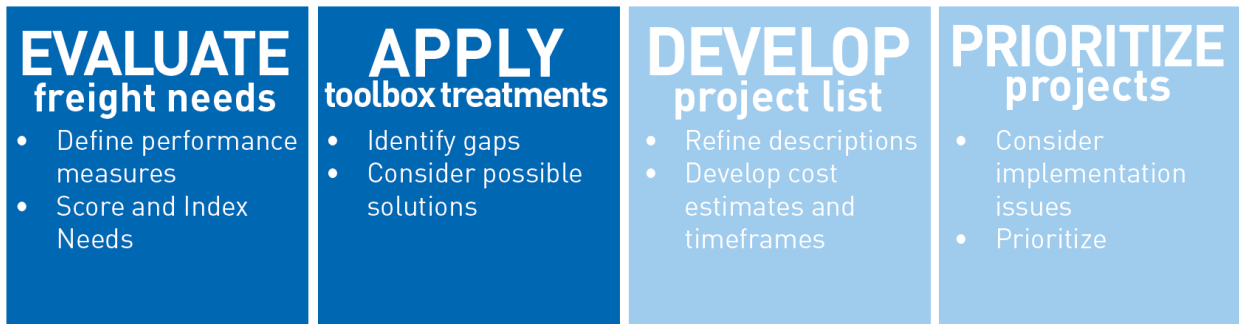











(Seattle DOT, Port of Seattle, 2015)

Seattle evaluates every potential project within the framework of four potential goals (safety, mobility, connectivity, and environmental). Every project serves to improve environmental impacts. Moreover, each potential project could apply any number of improvement strategies (see Exhibit 2) that serve to achieve any of the aforementioned goals. This methodology develops a matrix that allows the city to “score” a pool of prospective projects and produce an effective prioritization list:

Exhibit 2: Improvement Strategies, Project Goals, and Matrix

• Maintenance and preservation	• ITS applications
• Capital investments	• Geometric improvements
• Intersection operations	• Freight management
• Wayfinding for trucks	

Goal	Objective	Performance Measures and Data
Safety	Increase safety for all modes	• Truck collision history
Truck Mobility, Reliability, & Throughput	Maintain and improve freight-truck mobility and access	• Volumes & vehicle classifications • Speed (from Chapter 3 & 4) • Buffer index*
Connectivity	Ensure network connectivity, especially for major freight inter-modal facilities	• Mobility constraints (e.g. railroad crossings, geometric constraints, intersection operations, over-legal limitations)
Environment*	Reduce environmental impacts	• Congestion/delay- from speed & travel time • Stormwater management

No.	Project Name	Project Need	Project Type						
		 SAFETY  MOBILITY  CONNECTIVITY	Maintenance & Preservation	Capital Investment	ITS Application	Intersection Operations	Wayfinding for trucks	Geometric	Ongoing Programs
Ballard/Interbay Northend MIC									
22	15th Avenue West Spot Improvements at W Dravus Street and W Emerson Street	 						✓	
52	BINMIC Truck Route Improvements	 				✓	✓	✓	
Greater Duwamish MIC									
5A	East Marginal Way South Roadway Rehabilitation	 	✓	✓	✓				
5B	E Marginal Way S / S Hanford Street Intersection Improvements	 	✓	✓		✓			

(Seattle DOT, Port of Seattle, 2015)

Many of the projects included in Seattle’s Freight Access Plan do not provide design guidelines for truck access at specific nodes. Some projects, however, provide a rich context as to how connections throughout metropolitan areas can affect truck movement to a particular node. For instance, the *15th Avenue West Spot Improvements* project addresses turn radii issues for trucks through small-scale geometric and intersection operational improvements (see Exhibit 3). The *East Marginal Way South Freight Roadway Rehabilitation* project evaluates the critical last-mile connector which provides access to Port of Seattle terminals, rail yards, and other industrial land uses in the Greater Duwamish manufacturing and industrial center. The route is also a vital route for trucks carrying over-sized or flammable cargo so the project also looks at optimizing safety within the route (see Exhibit 4). The project also seeks to rebuild the roadway to Heavy Haul route standards, upgrades signal hardware, and adds CCTV camera and dynamic message signs to improve overall truck travel conditions. Finally, the *Lower Spokane Street Freight Only Lanes Pilot Project* seeks to design, implement, and evaluate freight-only lanes on this major corridor that serves nearly 5,000 trucks daily in addition to connecting the Port terminals and providing other land uses to the regional highway system (see Exhibit 5).

PROJECT AREA

#22 – 15th Avenue West Spot Improvements W Dravus Street and W Emerson Street



Project Cost: \$700,000

Exhibit 3

Freight Need

- ✓ Geometric constraints
- ✓ Recurring peak period congestion

Description

This project addresses turn radii issues for trucks through small-scale geometric and intersection operational improvements along 15th Avenue W. Trucks of all sizes experience challenges traveling on the elevated structures at W Emerson Street and W Dravus Street. 15th Avenue W, W Emerson Street, and W Dravus Street are vital connections for freight traveling to and from the Ballard/Interbay Northend Manufacturing and Industrial Center (BINMIC). This project includes two components to implement changes at these locations.

- The W Emerson Street ramp over 15th Avenue W serves trucks going to and from W Nickerson Street. This component includes moving the centerline on the ramp to provide a greater turning radius for trucks and making adjustments to the stop bars at the intersection on the west side of the ramp.
- W Dravus Street is used by trucks of all sizes, including over-legal vehicles unable to pass underneath the bridge on 15th Avenue W. Northbound trucks have particular difficulty turning left onto W Dravus Street from the off-ramp. This component of the project includes upgrading signal timing and hardware at the ramp terminals to ensure vehicle queues on the bridge clear to allow trucks adequate space to turn at the intersection.

Toolbox Treatments

Geometric Improvement

Intersection Operations

Project Elements

- ✓ Moving roadway centerline to improve turning radius
- ✓ Upgraded signal timing and hardware

Project Benefits

- ✓ Improved freight mobility
- ✓ Maintained connectivity
- ✓ Geometric improvements

Current Status

- ✓ Timeframe: 2015-2020
- ✓ Unfunded

Related Projects

- ✓ BINMIC Truck Route Improvements (#52)
- ✓ South End Ballard Bridge Bicycle Improvements



mobility
reliability
throughput



connectivity

(Seattle DOT, Port of Seattle, 2015)

#24 – Lower Spokane Street Freight Only Lanes Pilot Project Harbor Island to Airport Way South

Freight Need

- ✓ Recurring peak period congestion
- ✓ Heavy daily truck volumes

Description

Lower Spokane Street is a primary freight route serving nearly 5,000 trucks daily and connecting the Port terminals and other land uses to the regional highway system. It currently experiences delays throughout the day caused by train crossings and intersection operations. This pilot project would design, implement, and evaluate freight-only lanes on the corridor. The first phase of the project would determine project limits; identify design options and new infrastructure needed to implement the pilot. The second phase would implement the modifications to roadway channelization for truck-only lanes, install signal and signage upgrades, and provide ITS equipment such as variable message signs and detection equipment. The project would evaluate time-of-day operations, while providing a contingency for allowing all traffic to use the lanes in the event of an incident on the upper bridge.

Toolbox Treatments

Intersection Operations

ITS Applications



mobility
reliability
throughput



connectivity

Project Elements

- ✓ Signal and signage improvements
- ✓ Roadway delineation and restriping
- ✓ Variable message signs and detection equipment

Project Benefits

- ✓ Improved freight mobility
- ✓ Improved freight connectivity

Current Status

- ✓ Timeframe: 2015-2017 (Study)
- ✓ Unfunded

Related Projects

- ✓ S Spokane Surface Street ITS (#25)

PROJECT AREA



(Seattle DOT, Port of Seattle, 2015)

PROJECT AREA

#5A – East Marginal Way South Freight Roadway Rehabilitation S Massachusetts Street to S Dakota Street (SR 99 ramps)



Freight Need

- ✓ Heavy truck volumes
- ✓ Recurring peak period congestion
- ✓ History of truck-bike collisions

Description

This roadway provides access to Port of Seattle terminals, rail yards, and other industrial land uses in the Greater Duwamish MIC. It is a critical last mile connector and a vital route for trucks carrying over-sized or flammable cargo. It serves as an important connection between the Greater Duwamish MIC and BINMIC areas. The roadway experiences recurring congestion during peak travel times. This project rebuilds the roadway to Heavy Haul route standards, upgrades signal hardware, and adds CCTV cameras and dynamic message signs to improve truck travel conditions.

Toolbox Treatments

Maintenance & Repair

Capital Investment

ITS Application



safety



mobility
reliability
throughput

Project Elements

- ✓ Heavy Haul route rebuild
- ✓ Roadway upgrades
- ✓ Upgrade signal timing and hardware (ITS)

Project Benefits

- ✓ Reduced travel time and increased roadway resiliency
- ✓ Last mile connector and Heavy Haul route
- ✓ Improved freight mobility
- ✓ Improved safety

Current Status

- ✓ Timeframe: 2015-2020
- ✓ Partially funded: ~\$250,000 (concept design)

Related Projects

- ✓ SDOT Multimodal Corridor Project
- ✓ E Marginal Way / S Hanford Street Intersection Improvements (#5B)
- ✓ Hanford & Main SIG Access Improvements (#15)

(Seattle DOT, Port of Seattle, 2015)

The importance of connecting both the broader scope of truck movements within metropolitan areas and design guidelines within truck access nodes cannot be understated. California faces

many of the same issues presented in the Seattle case studies: geometric constraints in designing truck routes, massive periods of congestion and heavy truck volumes in arterial routes connecting to major marine terminals such as the Los Angeles/Long Beach port complex; the push for active transportation initiatives; safety concerns; and overall efficiency in freight mobility and connectivity are but a few among a wealth of other concerns. Gaining perspective as to how much our economic vitality relies on trucking efficiency should create urgency in providing the resources necessary for ports, docks, airports, and distribution centers to optimize truck flow within their respective facilities.

Weigh-in-Motion

Traditionally, static weighing was used to enforce weight limits. However, static weighing leads to freight inefficiencies in terms of delays and staffing demands. Staff is needed to intercept trucks in traffic flow to perform the weighing operation and to issue fines or apply other penalties to violators. Given that the static weighing process may take 10 to 30 minutes (sometimes more), the weighing area may be congested—causing delays. Further, overload trucks may bypass the check point, a violation that raises safety concerns.

To increase regulation and efficiency, technologies were developed to address the concerns listed above. Weigh-in-motion (WIM) technologies have been developed and implemented to address inefficiencies related to static weighing. “WIM technologies allow trucks to be weighed in traffic flow without any disruption to operations” (Jacob & Feypell, 2010).

WIM systems were first introduced in the United States in the mid-1950s. Since then, technological innovations have advanced the transportation system to include: low-speed WIM to high-speed WIM, road sensors, bending and load cell plates, strip sensors, multiple sensor, bridge WIM, video and automatic vehicle identification, among other applications, to increase freight efficiency and mitigate accidents and maintenance costs (Jacob & Feypell, 2010).

Furthermore, countries around the world are using WIM for enforcement. For instance, Taiwan implements high-speed WIM systems with large tolerances to enforce container weight regulations. Canada also operates high-quality and high-speed WIM systems to promote freight efficiencies as shown below:

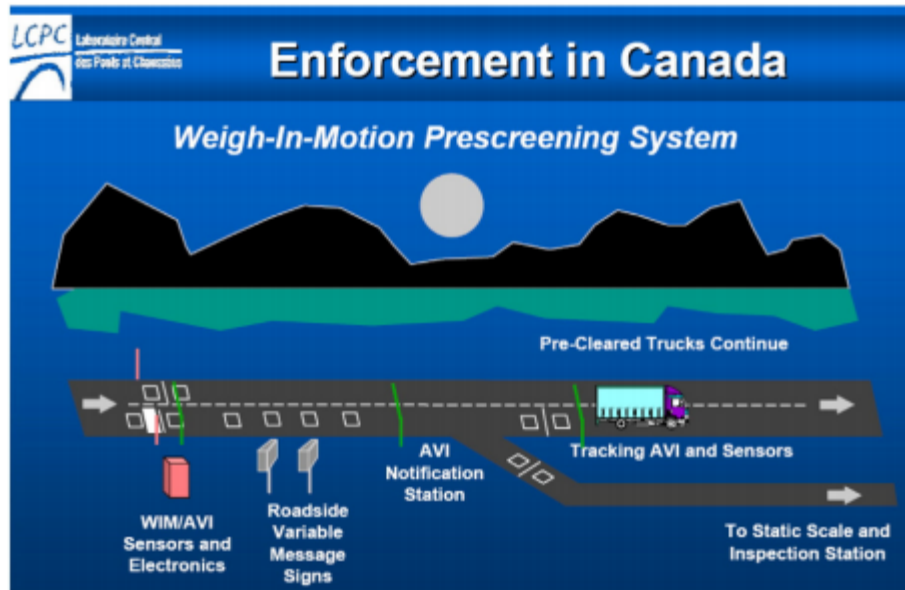

Due to the ensuring weigh pads implemented with the road surface to minimize vehicle dynamics (or bounce against the pavement), these high-speed WIM systems are very accurate in weighing trucks. Once the WIM system identifies a potentially overloaded truck, it diverts them to a weighing area. If the weigh station is not staffed, WIM only records for statistical purposes. Transportation systems in the Netherlands, France, Sweden, Japan, and other countries, however, use video cameras to constantly monitor overloads and send warnings to transport companies. Jacob and Feypell (2010) report that countries that implemented WIM technologies in 2007 experienced a reduction of up to 50 percent of the overloads observed. Although economic crisis and impact of road freight transport volume may have contributed to this reduction, this shows that this practice is very efficient in reducing overloading (Jacob & Feypell, 2010).

In terms of freight efficiency, implementing WIM systems will allow trucks to prove that they meet weight regulations without adding to their travel time. Trucks will be able to continue on their journey to distribution nodes without having to stop or wait in a queue to be weighed. With the WIM system, trucks are only required to drive over a pair of wired magnetic loops and a force sensor to be weighed as shown below:

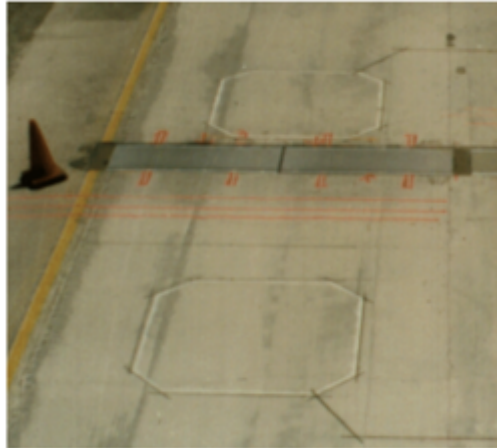

(Bajwa, 2013).

WIM technologies are effective in identifying trucks carrying overweight containers. “Trucks exceeding the legal mass limits increase the risk of traffic accidents and damage to the infrastructure. They also result in unfair competition between transport modes and companies” (Jacob, Feypell, 2010). In addition to being a danger on the road, overweight containers prove dangerous in port terminals and for the workers handling the containers.

According to the World Shipping Council (WSC) and the International Chamber of Shipping (ICS), overweight containers have proven challenging for industry, insurance, government, and the general public. After a joint industry-government research project regarding cargo securing that includes collapsing container stacks, the Maritime Research Institute of the Netherlands concluded that regulations for “compulsory weighing of containers prior to vessel loading” are needed (WSC and ICS, 2010).

This is because there is no reliable data that indicates how many containers are overweight. Some carriers report that it is not unusual for the total cargo weight aboard a ship to be three to seven percent greater than the declared weight. In a 2005 study by the Institute of Transportation Studies at the University of California, Berkeley, the average overload on freight trucks was more than five percent while the worst offenders averaged more than nineteen percent (ITS International, 2014).

The problems resulting from overweight containers include:

- Incorrect vessel stowage;
- Restowage of containers that result in delays and costs;
- Collapsed container stacks;
- Containers lost overboard;
- Cargo liability claims;
- Chassis damage;
- Damage to ships;
- Stability and stress risks for ships or mode of delivery;
- Risk of personal injury or death by workers;

- Impairment of service schedule integrity;
- Supply chain service delays;
- Exceed port draft limit;
- Lost revenue and earnings;
- Liability for accidents and fines;
- Time and costs with additional administrative efforts;
- Impairment of efficiency;
- Greater use of fuel;
- Greater vessel air emissions that is harmful to the environment and result in more fines (WSC and ICS, 2010);
- Disproportionate amount of road damage (ITS International, 2014);
- Accident risk and accident severity;
- Damage to infrastructure; and
- Unfair competition between transport modes and companies (Jacob & Feypell, 2010).

A reason for overweight containers is the switch from commodity pricing to container pricing (JOC Staff, 2016). This means that despite how full or empty a container is, companies are charged by the container.

In addition, Cottrell found that some truck drivers with overweight vehicles tend to bypass stationary weigh stations to avoid being cited for weight violations or motor carrier safety violations (1992). For example, in California, there are more than 125 weigh stations operated by the California Highway Patrol. The majority of the weigh stations are classified as mini-sites and are often unstaffed; however, when staffed and in operation, the California Highway Patrol found that “weight or loading violations are observed on a regular basis” (ITS International, 2014). The 2005 study by the Pavement Research Center estimates that between one and two percent of 78 million trucks are overloaded (2014). It is difficult to safely perform checks on heavily trafficked highways, and with high-traffic volume and number of heavy vehicles, the probability of being weighed is low (Jacob & Feypell, 2010).

Bypassing regulations leads to unfair competition between transport modes and companies that do obey the law and this impacts the economy. In France, it was estimated that a truck operating with a 20 percent overload all year round, generates an additional 25,000 euros every year. The illegal benefits of moving overloaded containers include tax evasion and additional profits. And while the operators benefit from such illegal practices, the burden falls on the state which must take on unaccounted for infrastructure and maintenance fees associated with overloaded containers (Jacob, & Feypell, 2010) and (ITS International, 2014).

To address the issue of overweight containers, “new technologies are being developed for more efficient overload screening and enforcement” (Jacob & Feypell, 2010). The Federal Highway Administration (FHWA) recommends an increase in the number of weigh-in-motion systems on highways to monitor truck loads.

Expected Benefits

There are many benefits to implementing WIM systems as it discourages overloaded trucks by allowing states to enforce container weight limitation regulations. For example, it is shown that

an overloaded truck is more likely to be involved in an accident and result in greater damage to other vehicles or infrastructure as depicted below:



(Jacob & Feypell, 2010).

Such hazards are due to truck instability due to the braking system being unable to respond to the excess load, loss of maneuverability, or tire overhead, and increase risk of fire and severity of fire due to an accident or loss of control. WIM systems can mitigate chances of traffic accidents by decreasing the number of overloaded trucks. This will reduce costs for transport companies and states as it reduces travel time for many transport companies which may be caught in traffic accidents or delays to clean the road of the cargo and remove the vehicle, and damage to roads and highways (Jacob & Feypell, 2010).

In addition, states will also have less maintenance costs. The California Department of Transportation calculated that 10 percent axle overload results in 40 percent increase in road damage. This means that overloading containers have a major impact on the life of road's service (ITS International, 2014).

Furthermore, overloading leads to significant distortions in freight transport competition. This is true between different transport modes, e.g., rail, waterborne, and road, and between road transport companies and operators as overloading is a violation of taxation rules, such as vehicle registration fees, axle taxes, and toll infrastructure fees (Jacob & Feypell, 2010). By allowing some companies to overload their containers, bypass regulations, and skirt penalty fees, state agencies create an unfair industry market that may impede competition and encourage a monopoly in the transport industry.

By implementing WIM systems, states are addressing the problem of overloaded containers. In terms of freight efficiency, costs from overloaded containers, such as collapsed container stacks, cargo liability claims, chassis damage, risk of personal injury or death by workers, impairment of service schedule integrity, supply chain service delays, lost revenue and earnings, liability for accidents and fines, time and costs of additional administrative efforts and fuel are decreased or eliminated. Furthermore, WIM systems can significantly reduce the time

spent weighing containers to zero as it is done while the truck is travelling to its next destination.

As recommended by the Federal Highway Administration, the WIM system also helps ports decrease harmful air emissions from idling trucks in the weigh station queue (FHWA, 2015).

Expected Costs

According to Bajwa (2013), current technologies for high quality WIM are too expensive to maintain and for widespread deployment. A unit with a lifetime of 10 years costs about \$497,000 for installation and \$6,240 for operation and maintenance (Caltrans, 2007). The high cost is due to the large and expensive load sensors and special pavement construction around those sensors.

An alternative WIM system that is less than a tenth of the cost is a vibration-sensor-based platform for an alternative intelligent transportation system technology. However, the lifetime for this is only two years (Bajwa, 2013). Therefore, there is a need for further research and development of inexpensive but accurate WIM systems that may be installed on new or existing roads.

Role of the Public Sector

In response to the negative effects of overloaded containers, the International Maritime Organization created a new regulation under the Safety of Life at Sea (SOLAS) mandating that all containers must have verified gross mass (VGM) documents if they are to be loaded onto a ship. The document must also be signed either electronically or in hard copy by the shipper with the verified weight. This regulation came about after incorrect weight documentation contributed to maritime casualties on the southern U.K. coast in 2007 and the partial capsizing of a feeder ship in the Spanish Port of Algeciras in June, 2015 (JOC Staff, 2015).

Although this regulation focuses on containers loaded on ships, there are many transport companies that use multimodal transport. Therefore, this regulation helps prevent overloaded containers on trucks and railways as well.

However, details pertaining to the law are unclear, e.g., enforcement, margin of error allowed, and directions to handle containers that arrive at a port without the necessary documentation or the incorrect VGM. At this time, what is known is that the law provides two options to meet regulations:

1. “Weigh the container on a truck as it passes over a weigh station, subtracting the weight of the truck, chassis and fuel to determine the weight of the loaded container; or
2. Weight each item going into a container and add the sum of all the goods loaded to the tare weight of the container” (JOC Staff, 2015).

The U.S. Federal Maritime Commission needs to create clear and well-defined laws so transport companies and government agencies are better able to meet container weight regulations. Elsewhere, Japan has drafted guidelines and revised ministry ordinances that outline penalties and variations between the VGM and actual weight of a container, which includes administrative punishments such as fines for violators of the new international rules scheduled to be promulgated on April 1, 2016 (JOC Staff, 2016).

Implementation Challenges

In addition to the high costs of high quality WIM systems, implementation challenges include a range of high maintenance costs, e.g., sensor durability under heavy loads, road damage, and pavement management as the sensor may be greatly affected by pavement temperature (Bajwa, 2013). Furthermore, there are problems for transport companies and government agencies in meeting the International Maritime Organization’s new regulation.

According to the Journal of Commerce (2015), too many transport companies and government agencies are unprepared for the implementation of the new law, which goes into effect on July 1, 2016. Although weight information is required for the safe operation of vessels, some shippers say that it is not clear how to meet the options provided by the mandate.

In addition, the United States Coast Guard declares that it will not be responsible for policing the container weight mandate, and that enforcement will go to the ports. The Coast Guard will only be involved if it “boards an incoming vessel and finds it doesn’t have VGM for each box” (JOC Staff, 2016). This means that ports must develop policies to enforce the mandate, and transport companies and government agencies must anticipate how ports will enforce it this coming July.

Measuring Success

In terms of freight efficiency, the success of implementing WIM systems widespread may be gauged in terms of time, vehicles gas mileage, and how air emissions are reduced or negated. Further benefits—e.g. reduced overloading containers, infrastructure maintenance costs, highway traffic accidents, among other metrics—may need further study and research after the new weight limitation mandate. Also, the benefits of WIM systems depend on how strict the public sector and ports regulate weight restrictions on containers. The stricter they are, the more beneficial and important WIM systems become to freight efficiency.

Conclusion

After reviewing a wide range of technological and planning strategies to promote operational modernization at distribution nodes, the White Paper suggests a series of next steps to inform the development of the California Sustainable Freight Action Plan.

- Installing microgrids at marine terminals and other large distribution nodes makes possible not only the obvious environmental and energy self-sufficiency benefits but also operational modernization. Similarly, microgrids can also support the industry’s implementation of intelligent transportation systems (ITS) in trucking to promote other technological innovations that would benefit from the reliable and resilient power provided by microgrids. Such technologies include electrical toll collection, which greatly speeds traffic through toll booths, ramp metering, and traffic signal coordination. Given the expense and potential difficulties related to integrating microgrids into legacy infrastructure, this White Paper recommends that future research on this technology focus on incentive programs to expedite its implementation into traditional energy markets.

- Like microgrids, other innovative technologies that hold the promise of promoting operational efficiencies at truck nodes, should also be pursued in an integrated rather than siloed manner. Truck platooning is recognized as technology capable of reducing congestion on truck corridors. However, using new ITS applications to promote real-time information sharing of data gathered via platooning applications to truck nodes such as ports and distribution centers could empower future transportation professionals to anticipate and account for challenges while processing freight more efficiently. Truck platooning may play an important role in attaining this efficiency goal because it initiates the process of incorporating ITS into the cab.

For larger quantities of up-to-date, descriptive data to be attainable, a mosaic of systems deployed simultaneously is required. In this integrated and modernized future, truckers could presumably platoon through corridors to nodes, where they would access weigh-in-motion technology to eliminate a truck move, access a virtual container yard, or tap into an online supply chain scheduling system to determine the containers they were picking up long before they arrived at a marine terminal.

In the end, it will not be any one technology that will drive operational efficiency at trade nodes but rather a connected suite of integrated technologies that will be accounted for early in the planning phases and further enhanced by best practices in designed based guidelines.

It is important to understand that any recommendations for operational modernization at distribution nodes must account for the three interrelated goals outlined in Gov. Brown's executive order, which calls for: economic competitiveness, a move toward zero emissions, and operational efficiency. If all three of these goals are to be achieved, each must reinforce the other. For example, if zero-emission electric trucks are required in the future, it is imperative that distribution nodes—such as marine terminals, airports, border crossings, and distribution centers—are equipped with the electrical charging facilities to ensure that those zero-emission vehicles are able to recharge in a seamless manner that does not contribute to slower truck turns or extra truck moves to gain access to such facilities. Said another way, every strategy in the California Sustainable Freight Action Plan must engage the three-pronged focuses on economic competitiveness, environmental sustainability, and operational efficiency in an integrated rather than siloed manner.

References

- Alcántar-Ruiz, R., Orue-Carrasco, F., & Martínez-Flores, J. (2014). Statistical model predicting freight transport fuel efficiency. *Global Conference on Business & Finance Proceedings*, 9.1, 537.
- American Highway Users Alliance. (2015). Unclogging America's arteries 2015 prescriptions for healthier highways. *CPCS Transcom Inc*. Retrieved from <http://www.highways.org/wp-content/uploads/2015/11/unclogging-study2015-hi-res.pdf>.
- American Transportation Research Institute. (2015). New research assesses potential for driver-assistive truck platooning. Retrieved from <http://atri-online.org/2015/05/27/new-research-assesses-potential-for-driver-assistive-truck-platooning>.
- American Transportation Research Institute & Federal Highway Administration. (2011). ATRI and FHWA release bottleneck analysis of 250 freight significant highway locations. Retrieved from <http://atri-online.org/2011/09/21/atri-and-fhwa-release-bottleneck-analysis-of-250-freight-significant-highway-locations>.
- Auburn University. (2015). Auburn university participates in heavy duty truck platooning study. Retrieved from <http://www.truckinginfo.com/news/story/2015/05/truck-platooning-report-shows-fuel-economy-gains.aspx>.
- Azra, H., Englund, C., & Wedlund, J. (2013). Current gaps, challenges and opportunities in the field of road vehicle automation. Retrieved March 7, 2016, from http://www.vinnova.se/PageFiles/751290059/2013-05620_EN.pdf
- Bajwa, R. (2013). Wireless weigh-in-motion: Using road vibrations to estimate truck weights (Doctoral dissertation). Available from University of California at Berkeley (UCB/EECS-2013-210).
- Bourgeois, T., Gerow, J., Litz, F., and Martin, N. (2013). Community microgrids: Smarter, cleaner, greener. *Pace Energy and Climate Center Pace Law School*.
- Bureau of Transportation Statistics, (2004). National Transportation Statistics 2004, 4. Retrieved from http://www.rita.dot.gov/bts/sites/rita.dot.gov.bts/files/publications/national_transportation_statistics/2004/pdf/entire.pdf.
- California Air Resources Board. (2010) Making the Case for Hybrid and Electric Trucks and Buses. *Calstart*. Retrieved from <https://www.californiahvip.org/making-the-case>.
- California Energy Commission. (2016). Ports energy collaborative. Retrieved from http://www.energy.ca.gov/highlights/documents/ports_energy_collaborative.pdf.

- Caltrans. (2007). Unit cost element - Mainline (highway speed) WIM scale. *U.S. Department of Transportation*. Retrieved from <http://www.itscosts.its.dot.gov/its/benecost.nsf/ID/D0C88FEAAD07C62585257745003F15DB?OpenDocument>.
- Cassidy, W. (2014). Trucking enters new era of supply chain connectivity. *Journal of Commerce*. Retrieved from http://www.joc.com/trucking-logistics/trucking-enters-new-era-supply-chain-connectivity_20140818.html.
- Chan, A. (2012). Nation's largest microgrid online. *Rocky Mountain Institute*. Retrieved from http://www.rmi.org/nations_largest_microgrid_online_esj_article.
- Chicago Metropolitan Planning Agency, (2010). Go to 2040: Comprehensive regional plan, 305. Retrieved from http://www.cmap.illinois.gov/documents/10180/17842/long_plan_FINAL_100610_web.pdf/1e1ff482-7013-4f5f-90d5-90d395087a53.
- Clevenger, S. (2012, July 30). Fleets enjoy fuel efficiency gains in new trucks, but express concerns on maintenance costs. Retrieved from <http://www.ttnews.com/articles/printopt.aspx?storyid=29837>.
- Cottrell Jr., Ben H. (1992). The avoidance of weigh stations in Virginia by overweight trucks. *Virginia Transportation Research Council & Federal Highway Administration*. Retrieved from http://www.viriniadot.org/vtrc/main/online_reports/pdf/93-r2.pdf.
- Davies, A. (2015, June 24). Making trucks more efficient isn't actually hard to do. Retrieved from <http://www.wired.com/2015/06/making-trucks-efficient-isnt-actually-hard/>.
- DKS Associates. (2013). Portland region Westside freight access and logistics analysis. 2-4. Retrieved from https://www.portofportland.com/pdfpop/Trade_Trans_Studies_Westside_Freight_Access.pdf.
- eModal. [company website]. Retrieved from <http://welcome.emodal.com/?ReturnUrl=%2fDefault.aspx#ports>.
- Evans, M. (2016). Align efficiency programs, incentives and capital improvements with emerging microgrid projects [Press release]. Retrieved from <http://www.marketwired.com/press-release/align-efficiency-programs-incentives-capital-improvements-with-emerging-microgrid-projects-2092364.htm>.
- Federal Highway Administration. (2015). Freight and air quality handbook. *U.S. Department of Transportation*. Retrieved from <http://ops.fhwa.dot.gov/publications/fhwahop10024/sect3.htm>.

- Fleming, B. (2012). New automotive electronics technologies [automotive electronics]. *IEEE Vehicular Technology Magazine*, 7.4, 4-12.
- Gladstein, Neandross & Associates, (2013). Moving California forward: Zero and low-emission goods movement pathways, 61. Retrieved from http://www.ucsusa.org/sites/default/files/legacy/assets/documents/clean_vehicles/Moving-California-Forward-Report.PDF.
- Giuliano, G., O'Brien, T., Dablanc, L., & Holliday, K., (2013). NCFRP report 23: Synthesis of freight research in urban transportation planning. *Transportation Research Board*, 6, 49. Retrieved from http://onlinepubs.trb.org/onlinepubs/nctfp/nctfp_rpt_023.pdf.
- Hanh, L., (2003). The logistics of empty cargo containers in the southern California region: Are current international logistics practices a barrier to rationalizing the regional movement of empty containers. *Freight Works*, 27, 28. Retrieved from: <http://www.freightworks.org/Documents/Logistics%20of%20Empty%20Containers%20in%20the%20Southern%20California%20Region.pdf>.
- Islam, S., Arthanari, T., Olsen, T., (2010). Empty container-truck movement problem: At ports of Auckland. *University of Auckland, New Zealand*, 242-244. Retrieved from: https://secure.orsnz.org.nz/conf45/program/Papers/ORSNZ2010_Islam.pdf.
- ITS International. (2014). Weigh in motion helps Caltrans minimize road damage. Retrieved from <http://www.itsinternational.com/categories/classification-data-collection/features/weigh-in-motion-helps-caltrans-minimise-road-damage>.
- Jacob, B. & Feypell-de La Beaumelle, V. (2010). Improving truck safety: Potential of weigh-in-motion technology. *International Association of Traffic and Safety Sciences*, 34(1), 9-15. doi:10.1016/j.iatssr.2010.06.003.
- Janssen, R., Zwinjnenberg, H., Blankers, I., & Kurijff, J. (2015). Truck platooning: Driving the future of transportation. *TNO*. Retrieved from publications.tno.nl/publication/34616035/dLijFM/janssen-2015-truck.pdf.
- James, R., & New York Metropolitan Transportation Coordinating Committee, (2006). The virtual container yard (VCY): A springboard for advancing port efficiency and environmental stewardship, 13. [Presentation]. Retrieved from http://www.nymtc.org/project/freight_planning/Meetings/FTWG112806%20NYMTTC%20VCYPres%20%20PP-final.pdf.
- JOC Staff. (2015). Shippers' guide to the container weight mandate. *Journal of Commerce*. Retrieved from http://www.joc.com/regulation-policy/transportation-regulations/international-transportation-regulations/jocs-container-weight-mandate-guide_20151214.html.
- JOC Staff. (2016). Solas enforcement goes to the ports. *Journal of Commerce*.

- Kahaner, L. (2015). Platooning is closer than you think – just like the trucks. Retrieved from <http://fleetowner.com/driver-management-resource-center/platooning-closer-you-think-just-trucks>.
- Knowler, G. (2015). New SOLAS rules have port equipment makers weighing options. *Journal of Commerce*. Retrieved from http://www.joc.com/maritime-news/new-solas-rules-have-port-equipment-makers-weighing-options_20151218.html
- Klemick, H., Kopits, E. , Wolverton, A. , & Sargent, K. (2015). Heavy-duty trucking and the energy efficiency paradox: Evidence from focus groups and interviews. *Transportation Research Part A: Policy and Practice*, 77, 154-166.
- Magill, B. (2013). Microgrids: A new kind of power struggle in New York and Connecticut. *Greentech Media*. Retrieved from <http://www.greentechmedia.com/articles/read/microgrids-a-new-kind-of-power-struggle>.
- Larsson, E., Sennton, G., & Larson, J. (2015). The vehicle platooning problem: Computational complexity and heuristics. *Transportation Research Part C: Emerging Technologies*, 60, 258-277. doi:10.1016/j.trc.2015.08.019.
- Lewis, P. (2013). Preparing a nation for autonomous vehicles: Opportunities, barriers and policy recommendations. *The Eno Center for Transportation*. Retrieved from <https://www.enotrans.org/etl-material/preparing-a-nation-for-autonomous-vehicles-opportunities-barriers-and-policy-recommendations/>.
- Lockridge, D. (2015, June). Commentary: The reality of autonomous trucks. Retrieved from <http://www.truckinginfo.com/article/story/2015/06/commentary-the-reality-of-autonomous-trucks.aspx>.
- Martirano, L., Falvo, M.C., Sbordone, D., Arboleya, P., Gonzalez-Moran, C., Coto, M., Bertini, I., & Di Pietra, B. (2013). Zero network-impact buildings and smart storage systems in micro-grids. *Environment and Electrical Engineering (EEIC)*, 284-289. doi: 10.1109/EEEIC-2.2013.6737923.
- Masiello, R. (2013). Microgrids introduce issues for utilities. *Intelligent Utility*. Retrieved from <http://www.intelligentutility.com/magazine/article/329471/microgrids-introduce-issues-utilities>.
- Mongelluzzo, B., (2006). IAS upgrades virtual container yard system. *Journal of Commerce*. Retrieved from http://www.joc.com/maritime-news/ias-upgrades-virtual-container-yard-system_20061112.html.
- Mongelluzzo, B., (2006). Virtual container yard. *Journal of Commerce*. Retrieved from http://www.joc.com/maritime-news/virtual-container-yard_20061001.html.

- National Cooperative Freight Research Program. (2009). Project 14 - Truck drayage practices. *University of Texas Center for Transportation Research, & University of South Carolina*. Retrieved from http://onlinepubs.trb.org/onlinepubs/archive/NotesDocs/NCFRP14_Task3LiteratureReview.pdf.
- National Energy Technology Laboratory. (2014). How an NETL-managed microgrid demonstration project reduced peak power loads and improved power reliability at one of the nation's largest jails. *U.S. Department of Energy*. Retrieved from <http://netl.doe.gov/newsroom/news-releases/news-details?id=2b5bada1-4f12-44e5-bb69-5b5e1b706cfb>.
- Nasir, M., Noor, R. , Kalam, M. , & Masum, B. (2014). Reduction of fuel consumption and exhaust pollutant using intelligent transport systems. *The Scientific World Journal*, 1-13.
- New York State Energy Research & Development Authority. (2010). Microgrids: An assessment of the value, opportunities and barriers to deployment in the New York state. Retrieved from <http://www.ourenergypolicy.org/wp-content/uploads/2013/08/10-35-microgrids.pdf>.
- NOVA Technology. (2013). Dock planning standards, 5. Retrieved from <http://docslide.us/documents/nova-dock-planning-standards-guide.html>.
- Parise, G., Parise, L., Martirano, L., Chavdarian, P., Su, C., & Ferrante, A. (2016). Wise port and business energy management: Port facilities, electrical power distribution. *IEEE Transactions on Industry Applications*, 52.1, 18-24. doi: 10.1109/TIA.2015.2461176.
- Peloton. (2016). Peloton technology. Retrieved from <http://www.peloton-tech.com/about>.
- Ploeg, J., Serrarens, A., & Heijenk, G. (2011). Connect & drive: Design and evaluation of cooperative adaptive cruise control for congestion reduction. *Journal of Modern Transportation*, 19(3), 207-213.
- Port of Long Beach, (n.d.). Port Launches Virtual Container Yard. Retrieved from <http://www.polb.com/civica/filebank/blobdload.asp?BlobID=3755>.
- Port of Long Beach (2015). Program overview: Port of Long Beach energy island initiative. Long Beach, CA. Retrieved from <http://www.polb.com/civica/filebank/blobdload.asp?BlobID=13097>.
- Port of Los Angeles. (2014). Energy management action plan. Burns & McDonnell Engineering Company, Inc. Retrieved from https://www.portoflosangeles.org/DOC/DRAFT%20POLA%20E-MAP_July%202014.pdf.
- Port of Long Beach. (2015). Energy island. Retrieved from <http://www.polb.com/environment/energyisland.asp>.

- Port of New York, & Port of New Jersey, (2014). A Collaborative effort for a collective change, 21. Retrieved from: <https://www.panynj.gov/port/pdf/pptf-final-report-june-2014.pdf>.
- Portland Office of Transportation, (2008). Designing for truck movements and other large vehicles in Portland. 11,13. Retrieved from <https://www.portlandoregon.gov/transportation/article/357099>.
- Romankiewicz, J., Qu, M., Marnay, C., and Zhou, N. (2013). International microgrid assessment: Governance, incentives, and experience (IMAGINE). *China Energy Group*. Lawrence Berkeley National Lab.
- Sain, S. (2014). Electrification at ports: Plug-ins enabled. *American Association of Port Authorities Seaports*. Retrieved from <http://www.aapaseaports.com/index.php/2014/06/18/plug-ins-enabled/>.
- Sartre. (n.d.) Project partners. Retrieved from <http://sartreproject.eu/en/partners/Sidor/default.aspx>.
- Steenken, D., Voß, S., & Stahlbock, R., (2004). Container terminal operation and operations research - a classification and literature review. *OR Spectrum*, 26(1), 3-49.
- Seattle Department of Transportation & Port of Seattle, (2015). Seattle industrial areas freight access project. Retrieved from http://www.seattle.gov/transportation/freight_industrialareas.htm.
- Slack, B. (1990). *Intermodal transportation in North America and the development of inland load centers*. *Professional Geographer*, 42(1), 72-83.
- Soshinskaya, M., Graus, W., Guerrero, J. M., & Vasquez, J. C. (2014). Microgrids: experiences, barriers and success factors. *Renewable & Sustainable Energy Reviews*, 40, 659-672. doi: 10.1016/j.rser.2014.07.198.
- Sulbaran, T., & Sarder, M.D. (2013). Logistical impact of intermodal facilities. *American Society for Engineering Education*, 1(2), 4. Retrieved from: <http://se.asee.org/proceedings/ASEE2013/Papers2013/183.PDF>.
- Tindall, C. (2014). Autonomous platoons would reduce costs. *Commercial Motor*, 222(5610), 8.
- Theofanis, S., & Boile, M., (2007). Investigating the feasibility of establishing a virtual container yard to optimize empty container movement in the NY-NJ region. *Rutgers Center for Advanced Infrastructure and Transportation*. Retrieved from <http://www.utrc2.org/sites/default/files/pubs/Investigating-Feasibility-of-Establishing-Virtual-Container-Yard.pdf>.
- Wartian, M., Lyte, W., & Putnam, E. (2013). Electrical grid continuity in California port operations. [Presentation]. *Presented at METRANS International Urban Freight*

- Conference*. Long Beach, CA. Retrieved from <https://www.metrotrans.org/sites/default/files/WartianElectricEnergy.pdf>.
- Washington State Department of Transportation, (2014). Freight Mobility Plan. Retrieved from http://www.wsdot.wa.gov/NR/rdonlyres/75650145-A0E9-4069-9FFC-148B2134CB72/0/AppG_UrbanGoodsMovementStrategy.pdf.
- Winter, K. & Campbell, B. (2009). Technology helps us do things better: Virtual weigh stations, other new methods for enforcing the law prolong highway life and increase vehicle citations. *Virginia Department of Transportation*. Retrieved from <http://vtrc.viriniadot.org/rsb/RSB22.pdf>.
- World Shipping Council & International Chamber of Shipping. (2010). Solving the problem of overweight containers. [Public address]. Retrieved from http://www.worldshipping.org/public-statements/solving_the_problem_of_overweight_containers_for_release.pdf.
- Zhang, W., Huang, J., Tok, A., Chang, C., & Ritchie, S. (2014). The requirements and recommendations for development of a California weigh-in-motion test facility. State of California Department of Transportation. Retrieved from http://www.dot.ca.gov/newtech/researchreports/reports/2014/final_report_task_1798.pdf.