

eScholarship

International Journal of Comparative Psychology

Title

Lateralized Behavior of Bottlenose Dolphins Using an Underwater Maze

Permalink

<https://escholarship.org/uc/item/4dx6t5z5>

Journal

International Journal of Comparative Psychology, 29(1)

ISSN

0889-3675

Authors

Clark, Fay E
Kuczaj II, Stan A

Publication Date

2016

DOI

10.46867/ijcp.2016.29.00.19

Copyright Information

Copyright 2016 by the author(s). This work is made available under the terms of a Creative Commons Attribution License, available at <https://creativecommons.org/licenses/by/4.0/>

Peer reviewed



Lateralized Behavior of Bottlenose Dolphins Using an Underwater Maze

Fay E. Clark¹ and Stan A. Kuczaj II²

¹ *Royal Veterinary College London, Zoological Society of London, UK*

² *University of Southern Mississippi, USA*

Behavior is lateralized when it is performed preferentially by one side of the body, and this phenomenon is seen across a wide range of vertebrate taxa. Furthermore the brain and body are contralateral in many animals, meaning that the left brain hemisphere most dominantly controls the right side of the body and vice versa. Lateralized behavior in humans and nonhuman primates reveals a population right-hand bias. Recent studies in primates have also begun to link differences in lateralized behavior to task complexity, and responses to novel versus familiar stimuli. Parallel research on cetaceans is sparse although evidence accrued over the last decade suggests captive dolphins have a preference for swimming counter-clockwise, a right-eye advantage in spatio-cognitive tasks and a right-eye preference for viewing novel objects. This eye preference in dolphins is the reverse of the general vertebrate pattern. Lateralized behavior was examined in a group of six male bottlenose dolphins (*Tursiops truncatus*) in response to a novel underwater maze, and compared to behavior during a baseline phase (no maze present). Dolphins were significantly more likely to swim counter-clockwise round their pool during both the baseline and challenge phase, interpreted as significant right eye lateralization. This eye lateralization was also present during the challenge phase but was not significantly different from baseline. There was no clear preference for using the left or right side of the maze at the group level; however two high maze-using subjects had a strong right side lateralization. Modifications and extensions to the methods are discussed.

The right and left sides of the brain are specialized to process information in different ways and control different behaviors (MacNeilage, Rogers, & Vallortigara, 2009; Rogers, 2010). This lateralization was once thought to be a uniquely human trait, but is now known to occur across a diverse range of animal taxa (reviewed by Rogers & Andrew, 2002). Overall, the left brain hemisphere is generally thought to control 'routine' behaviors and following simple rules in the absence of stress; in contrast, the right hemisphere is thought to control behavior during unpredictable environmental change, and becomes more dominant in times of stress (MacNeilage et al., 2009; Rogers & Andrew, 2002). It thus follows that the right hemisphere is linked to the expression of intense negative emotions such as fear and aggression (Davidson, 1992, 1995). *Lateralized* behavior, preferentially performed by one side of the body in relation to the other, is a manifestation of the differences between the right and left brain. The brain and body are contralateral in vertebrates, so that the left brain hemisphere most dominantly controls the right side of the body and vice versa (Csermely & Regolin, 2013; MacNeilage et al., 2009). Behavioral lateralization helps us to understand how animals perceive their world, and whether they appraise different stimuli (or grades of the same stimulus) as relatively positive or negative (Rogers, 2010).

Lateralized behavior in primates, specifically chimpanzees (*Pan troglodytes*), has been studied intensively from an evolutionary perspective (de Waal, 2005; Hopkins, Tagliatalata, Leavens, Russell, & Schapiro, 2010). Like humans, the most salient example of lateralized behavior in primates is 'handedness' (preferential use of one hand over the other). Similar to 85-90% of the human population (Annett, 2002), chimpanzees also show a right-hand bias at the population level in the wild and captivity (reviewed by Hopkins et al., 2010; Ward & Hopkins, 1993) and this is generally consistent across feeding, grooming, using tools, and performing cognitive tasks (reviewed by Hopkins et al., 2010). The Task complexity hypothesis

(Fagot & Vauclair, 1991) states that handedness is stronger (i.e., further from equal use of the right and left hands) when *high-level* tasks (requiring complex object manipulation) are performed compared with *low-level* tasks (with lower cognitive and motor involvement). This hypothesis is supported in a range of nonhuman primate species (e.g., Lilak & Phillips, 2008; Llorente et al., 2011; Mosquera et al., 2012; Schweitzer, Bec, & Blois-Heulin, 2007).

In contrast to handedness, *eyedness* (preferential use of one eye over the other) has only recently been given attention in nonhuman primates, who have forward-facing eyes specialized for binocular vision (Braccini, Lambeth, Schapiro, & Fitch, 2012). There is a general trend across vertebrates to view novel objects and situations with the left eye, thus linking to the right hemisphere (reviewed by Blois-Heulin, Crével, Böye, & Lemasson, 2012; referred to as the Novelty hypothesis). For example, Braccini et al. (2012) found that chimpanzees tend to view novel stimuli with the left eye and food with the right. An alternate hypothesis, the Information treatment modality hypothesis (Navon, 1977, 1981) states that exploration of familiar objects favors appraisal of global characteristics and therefore the right brain (left eye); whereas exploration of novel objects favors close appraisal of detailed local characteristics and therefore the left brain (right eye). In support of this, horses (Arab breed mares) preferentially use their right eye to explore novel objects (De Boyer Des Roches, Richard-Yris, Henry, Ezzaoui, & Hausberger, 2008).

Compared with primates, far less is known about brain lateralization and lateralized behavior in cetaceans. Studies over the last two decades suggest that dolphins could have a degree of lateralized vision on a par with nonhuman primates. Unlike primates, cetaceans have eyes placed laterally on each side of the head, and generally use monocular vision due to a narrow binocular visual field. When monocular vision is forced (e.g., by occluding one eye with a suction cup), captive bottlenose dolphins (*Tursiops truncatus*) perform better when using their right eye in spatio-cognitive tasks above and below water (Kilian, von Fersen & Güntürkün 2000, 2005; von Fersen, Schall, & Güntürkün, 2000; Yaman, von Fersen, Dehnhardt, & Güntürkün, 2003). Delfour and Marten (2006) also found that dolphins had a right-eye advantage on underwater spatio-cognitive tasks when free sight was permitted (in this case the authors made inferences about subject's eye preference from their head and body alignment).

Overall, there seems to be more support for the Information treatment modality hypothesis (Navon, 1977, 1981) than the Novelty hypothesis (Blois-Heulin et al., 2012) in cetaceans; in other words more support for a right eye bias in novel situations. In a study of wild striped dolphins (*Stenella coeruleoalba*), Siniscalchi, Dimatteo, Pepe, Sasso, and Quaranta (2012) found a right-eye preference for looking at novel objects and a left eye preference for familiar objects. Blois-Heulin et al. (2012) found similar results in captive bottlenose dolphins; subjects preferentially used their right eye to observe unfamiliar objects, their left eye to observe familiar objects, and showed no preference for objects of intermediate valence. However, dolphins have also shown a right-eye preference for approaching and viewing objects and humans independent of their novelty (e.g., Ridgway, 1986; Yaman et al., 2003). Captive bottlenose dolphins, beluga whales and Pacific white-sided dolphins (*Lagenorhynchus obliquidens*) have been found to prefer viewing humans with their left eye, regardless of whether they were familiar or not (Thieltges, Lemasson, Kuczaj, Böye, & Blois-Heulin, 2011; Yeater, Hill, Baus, Farnell, & Kuczaj, 2014).

With regards to positional behavior, in other words how and when an animal positions itself in the physical environment (Prost, 1965), there is a general vertebrate pattern of a 'rightward action asymmetry' (MacNeilage, 2014), in other words a tendency to move the body towards the right. However, it is known that captive dolphins (and other cetaceans) tend to swim with a left rotation (i.e., counter-clockwise) around their pools (Blois-Heulin et al., 2012; Ridgway, 1972, 1986; Sobel, Supin, & Myslobodsky, 1994; but see Stafne & Manger, 2004 where a weak clockwise current in the pool may have caused the alternate swimming direction).

This left rotation preference may in fact be a by-product of right eye preference: turning left places the right eye towards the pool wall and therefore in the best position for surveillance of the outside world. This apparent right eye preference supports the hypothesis of a left hemisphere preference for processing novel situations and/or spatio-cognitive problems (Information treatment modality hypothesis: Navon, 1977, 1981). But interestingly, it goes against the general vertebrate pattern (including humans) of a right hemisphere preference for processing novel and unpredictable situations (Rogers, 2009; see MacNeilage, 2014 for detailed discussion).

The strongest manifestation of a rightward action asymmetry in cetaceans is that of feeding behaviors (Karenina, Giljov, Ivkovich, & Malashichev, 2016; MacNeilage, 2014). For example, wild orcas (*Orcinus orca*) show a preference for lunging towards the right (Karenina et al., 2016), and bottlenose dolphins show a preference for intentionally beaching on their right side (Sakai, Hishii, Takeda, & Kohshima, 2006), in pursuit of prey. Indirect evidence for a rightward feeding bias comes from disproportionately larger right flippers in harbor porpoises (*Phocoena phocoena*), white-beaked dolphins (*Lagenorhynchus albirostris*), and Commerson's dolphins (*Cephalorhynchus commersonii*), assumed to be due to preferential postural behavior towards the right when swimming (Galatius, 2006; Galatius & Jespersen, 2005; Gómez-Campos, Aguilar, & Goodall, 2010). Cetaceans have a skew of the midline of the skull towards the left, and parts of the anatomy are generally larger on the right side (Ness, 1967), which may reflect lateralized processing of prey information (Cranford, Amundin, & Norris, 1996). Alternatively, expansion on the right side may allow cetaceans to swallow larger prey, because the larynx protrudes to the left side (Macleod et al., 2007).

In comparison to eye preference and positional behavior, far less is known about the lateralized use of cetacean appendages (paired: pectoral fins; unpaired: rostrum, dorsal fin and tail). Dolphins do not use their pectoral fins to touch and manipulate inanimate objects in the same way primates would use their hands; fins are primarily for steering and controlling speed and have an auxiliary role in social interactions (Johnson & Moewe, 1999; Sakai et al., 2006). In a social context, it has been shown that wild whale mothers tend to swim with the calf on their right side (beluga whales, *Delphinapterus leucas*: Karenina et al., 2010, orcas: Karenina et al., 2016; MacNeilage, 2014). Wild bottlenose dolphins and Commerson's dolphins preferentially use their left pectoral fin to initiate social contact (Gómez-Campos et al., 2010; Johnson & Moewe, 1999; Sakai et al., 2006).

Even though "handedness" per se is not an applicable concept for cetaceans, it is surprising there have apparently been no studies on the lateralization of the dolphin rostrum or tail flukes as unpaired appendages. Recent studies of tail-wagging in domestic dogs suggest that the tail moves more to the left when subjects are exposed to negative stimuli (e.g., a more dominant dog, or absence of the subject's owner), versus a more rightward movement when exposed to positive stimuli (e.g., presence of the owner; Quaranta, Siniscalchi, & Vallortigara, 2007). Lateralization of the tail has also been demonstrated in spider monkeys (*Ateles geoffroyi*, Laska, 1998); and to a lesser extent trunk lateralization has been demonstrated in Asian elephants (*Elephas maximus*, Haakonsson & Semple, 2009).

This study aimed to contribute towards the study of dolphin lateralized behavior in a captive setting; specifically in response to a novel, static underwater problem-solving device. The underwater maze was primarily studied as a form of 'cognitive enrichment' (Clark, Davies, Madigan, Warner, & Kuczaj, 2013). We were interested to examine whether lateralized behavior extended outside the dolphin's own body parts and positional behavior, to be manifested in their use of the maze; in other words, if they used one side of the maze preferentially over the other. In order to test this fairly, the maze was bilaterally symmetrical (the right and left sides were mirror images) so that the right and left sides offered equal opportunity to solve the problem.

In the current study we predicted, that (1) based on previous findings in bottlenose dolphins in the Northern hemisphere, dolphins would have a leftwards swimming lateralization (i.e., turning counterclockwise around the pool). We made two competing predictions regarding eye lateralization during the challenge phase, following Blois-Heulin et al. (2012). In contrast to that study, we did not provide several objects of differing novelty, but rather compared lateralized behavior when the maze was present and absent. Our predictions were as follows: (2a) based on the Novelty hypothesis (Blois-Heulin et al., 2012) dolphins will preferentially use their left eye to view the maze and bias towards using the left side of the maze and pushing from left-to-right. Alternatively (2b) based on the Information treatment modality hypothesis (Navon, 1977, 1981) dolphins will preferentially use their right eye to view the maze and bias towards using the right side of the maze and pushing from right-to-left. Finally, (3) based on the Task complexity hypothesis (Fagot & Vauclair, 1991), we predicted that lateralized behavior would be stronger when subjects used maze, compared with baseline. Predictions are summarized in Figure 1.

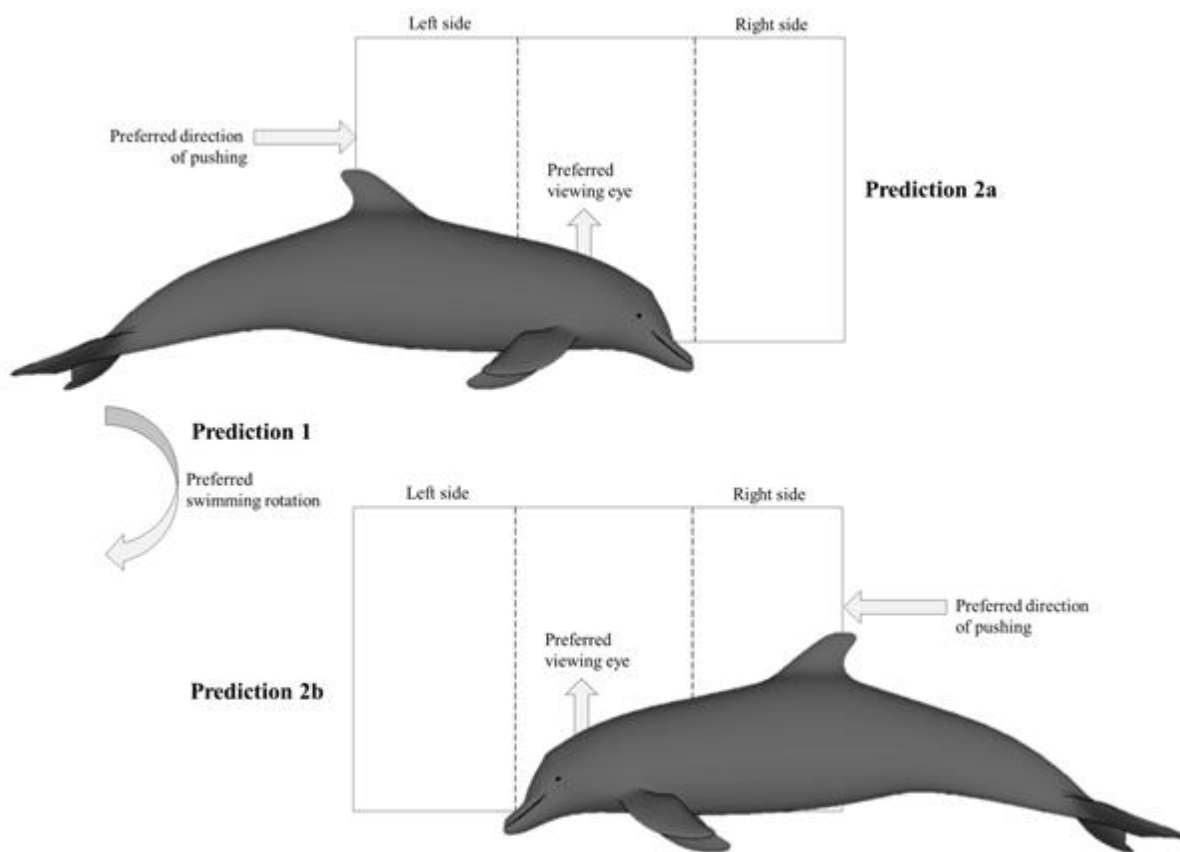

Figure 1. Illustration of predicted lateralized behavior in dolphins. Top image: lateralized behavior including maze use based on the Novelty hypothesis. There is a right brain hemisphere preference for novel objects or situations. Bottom image: based on the Information treatment modality hypothesis. There is a left brain hemisphere preference for processing the local characteristics of novel objects. Note in both cases the preferred swimming location is predicted to be counterclockwise as seen in other captive dolphins.

Method

Study Subjects and Housing

The study took place at Six Flags Discovery Kingdom, CA between April and May 2012. Study subjects were six male bottlenose dolphins housed in one group and tested socially (Table 1). One subject was sub-adult, based on the predicted age of brain maturation (Ridgway, 1986). The enclosure consisted of three concrete pools (one semi-circular stadium pool and two straight-sided backstage pools) interconnected by metal gates with underwater viewing windows (Figure 2). The maze was placed in the largest backstage pool (162,000 gallon volume, 4 meter depth), on a wall adjacent to two large underwater viewing windows. Dolphin interaction with the maze was entirely voluntary; we did not restrict the provision of normal diet, and normal management routines were maintained as much as possible over the course of the study. Data were collected Monday to Wednesday each week, when the facility was closed to visitors and pool cleaning was not taking place. Dolphins were fed four or five times across the day but not during research trials. The daily diet was a combination of high and low fat herring, capelin and gelatin cubes. To our knowledge, no subjects had ever been exposed to an underwater maze before, or any apparatus resembling our maze. During research trials, “toy” items in the pool consisted of a large basketball, a plastic float and two 5-m strips of fire hose tethered to underwater weights in the test pool. Research passed ethical review by the Royal Veterinary College and Six Flags Discovery Kingdom.

Table 1
Bottlenose Dolphin Study Subjects

Subject ID code	Age	Birth/rearing type	Years at facility
A	12	CM	12
B	18	CM	18
C	10	W	8
D	26	W	23
E	12	CM	12
F	22	CM	22

Note. All study subjects were male. Approximate ages are given for subjects who were wild born. CM: captive born, mother reared; W: wild born. Subjects B, E and F were half siblings with the same mother but different fathers (not present in group). Subject D was considered by animal care staff to be the dominant male. Subject C was sub-adult.

Maze Design and Procedure

The maze (Figure 3) was bilaterally symmetrical maze with three horizontal levels and a central entry and exit pipe. It was constructed from 102-mm diameter opaque white PVC plumbing pipe (Spears®, Sylmar, CA), T-shaped pipe connectors and pipe caps which were bolted and welded together at each joint. For safety, the edges of pipes and metal fixtures were rounded and sanded until smooth. The reward item inside the maze was a 90-mm diameter purple synthetic rubber “Squeezz”™ ball (Kong®, Golden, CO). A 760-mm channel running through the front of the pipes allowed dolphins to see and move the ball inside the pipes with their rostrum, but was too narrow to remove the ball completely. The ball was filled with non-toxic sand in order to make it slowly sink in salt water. The maze was ‘solved’ when a dolphin moved the ball by any strategy into the exit pipe, which was sealed so that balls collected here and did not fall into the pool. Therefore, solving the maze did not provide an external reward such as food, and there was no external reinforcement from staff or researchers. A dolphin could push or pull the maze using their rostrums, causing the ball to move within the pipes; alternatively, a dolphin could place their rostrum into the channel and move the ball horizontally and vertically (see Clark et al., 2013 for a discussion of different problem-solving strategies). Multiple balls were provided during a trial so that dolphins could solve the maze many times during a trial.

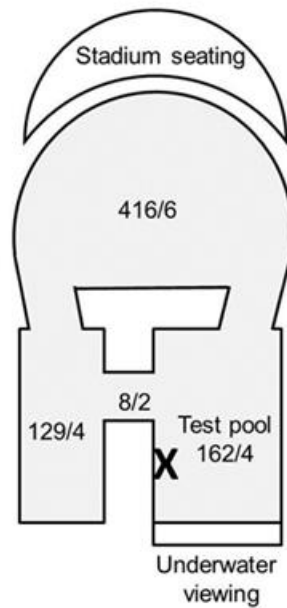

Figure 2. Plan view of the dolphin exhibit. Numbers within a pool represent its volume/maximum depth (1,000 gallons/m). The location of the maze is indicated by an “X”. Not to scale.

At the beginning of a trial, the maze was submerged in the test pool so that the rim of the entry pipe was approximately 30 cm below the surface of the water. The top of the maze was secured to a concrete pillar at the pool edge using abseiling rope and karabiner clips, allowing dolphins to move the maze but not swim off with it. A ball was placed into the entry pipe of the maze. Dolphins had access to all pools during trials, and were therefore not obligated to be in the same pool as the maze. No feeding, training or trainer interactions took place during trials.

We used the following procedure during the challenge phase in an attempt to maximize interest in the maze: (i) the maze was submerged in the pool for 30 min, (ii) the maze and any ball therein were removed for 15 min, (iii) the maze was re-submerged and re-set with a new ball in the entry pipe, and (iv) the maze remained in the pool for a final 30 min. Within each 30-min half-trial (parts i and iv in the sequence), each time a dolphin moved a ball into the exit pipe, the experimenter quickly placed another ball into the entry pipe. When experimenters attended to the device, they did not interact with dolphins, remaining silent and avoiding eye contact to prevent avoid extrinsic reinforcement.

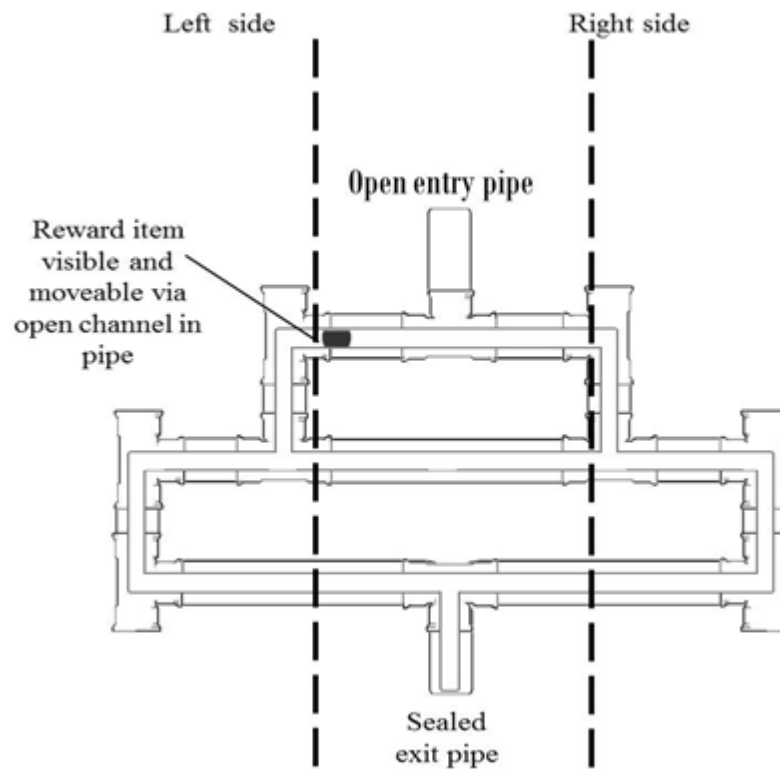

Figure 3. **Diagram of the dolphin maze.** Dashed lines show the delineation between left, middle and right sections. Not to scale. Dimensions: height 1.0 m; width 1.3 m; depth 110 mm, pipe diameter: 102 mm.

Behavioral Observations

Pilot. A week of unstructured pilot observations a month before the study began suggested that swimming was the only distinctly rotational behavior in dolphins; in other words the only behavior where their body clearly turned left or right. No lateralized use of toys or pool substrate was observed during the pilot study. Pilot data were for planning purposes only, and were not analyzed.

Baseline phase. Observations of dolphins under normal management conditions were undertaken by the primary author over a two-week period in April 2012. A total of 36 focal follows, each lasting 10 min were undertaken in the afternoon only (between 13:30 and 15:30 hrs) so that they fit between normal feeding sessions, across the two weeks. All subjects within the group were observed an equal number of times over the study period, but in random order each day (following Holobinko & Waring, 2010). Data were only collected when dolphins were in the test pool. When they swam into other pools, they were classified as being *out of sight*.

During each focal follow, observations were primarily made from above the water, but occasionally observations were made from underwater viewing window. Detailed behavioral data were collected as part of a larger study on dolphin cognitive enrichment (Clark et al., 2013), but here we will only describe the methods relevant to this study. Lateralized behavior was recorded using instantaneous sampling at 1-min intervals. At each 1-min sample point, the direction of any *circular* swimming, defined as forward swimming in a single general direction around the pool wall, was scored. This is in contrast to non-circular swimming, defined as forward swimming in a single general direction across the pool; or forward swimming with frequent changes in direction. Swimming was scored as *clockwise* if the dolphin took right-hand turns around the pool, and *counter-clockwise* if left-hand turns were made (Marino & Stowe, 1997). The word *rotation* was used rather than *direction* to describe swimming because the latter is a more generic term used in the lateralized behavior literature to describe the relative left/right preference of behavior (Hopkins et al., 2010).

Challenge phase. The maze was presented over a two-week period in May 2012, one week after the baseline phase and at the same time of day (between 13:30 and 15:30 hrs) from Monday to Wednesday. The maze was filmed using a high definition video camera (Panasonic SDR-H40, Panasonic Corp., Osaka, Japan) mounted on a tripod adjacent to the underwater viewing window. The camera continuously recorded dolphins in the pool, using the maze (approaching, observing and contacting) during a trial. Later the video data were re-played using Windows Media Player® and coded for each dolphin (Altmann, 1974; Martin & Bateson, 2007) for the total duration of the trial. Lateralized behavior was scored from video, using focal follows in the same manner as described for the baseline phase. Second, lateralized behavior (i.e., interaction with the maze) was scored from continuous observations of maze use. Each time a subject contacted the maze, the side touched, direction of pushing (left-to-right or right-to-left, if applicable) and movement and location of the ball were recorded.

Analyses

Lateralization was estimated at both individual and group levels. At the individual level, data were pooled for each trial within each phase (baseline and challenge), and subsequently analyzed for each phase. Following convention for lateralized behavior analyses (described by Hopkins et al., 2010) lateralization was quantified in terms of both its strength, which refers to the overall departure from no preference (i.e., equal use of the left and right) irrespective of the side, and direction, which refers to the general left-right preference of the behavior. Statistical analyses were undertaken using SPSS version 20 (SPSS, Inc., 2011)

Index scores. We calculated index scores to represent the strength and direction of lateralization. Index scores range from -1 to 1 with the absolute value representing the strength of the lateral bias; a value closer to 0 reflects equal use of the left and right side, whereas a value closer to 1 or -1 reflects a stronger lateralization. Positive values indicate right-hand bias, and negative values indicate left-hand bias.

It was not possible to reliably score which eye (or eyes) dolphins used to view the maze; therefore swimming rotation preference was used as a proxy for eye preference. Right rotation places the left eye towards the outside world and vice versa. An eye lateralization (EL) index was calculated using the following equation (after Blois-Heulin et al., 2012): $(R - L) / (R + L)$. In the baseline phase, R and L represent the frequency (or duration) of the right eye facing outwards (i.e., swimming counter-clockwise) and the left eye facing outwards (i.e., swimming clockwise) respectively. In the challenge phase, R and L represent the eye clearly facing towards the maze (dolphins have eyes placed on the sides of their head and therefore their bodies are aligned to one side if one eye is used and not the other, as shown in Figure 1). A maze side lateralization (MSL) index was calculated using the same equation above but in this case, R and L represent the frequency (or duration) of right and left contacts made to the maze. Finally a maze pushing lateralization (MPL) index was calculated using the same equation as above but in this case, R and L represent the frequency (or duration) of using the rostrum to push the maze from the right or left. Index scores were calculated for a subject if the total frequency of points sampled ($R + L$) were ≥ 15 .

Z-scores. Z-scores provided another means of quantifying rotation/sidedness and were derived using a binomial test. Similar to index score, z-scores were only calculated for a subject if the total frequency of points sampled ($R + L$) were ≥ 15 . Following common practice in the nonhuman primate lateralization literature (see Hopkins et al., 2010), subjects with a z-score > 1.96 are significantly right-lateralized and subjects with a z-score < -1.96 are significantly left-lateralized. Subjects with z-scores between these values are ambilateral.

In order to address potential confounds to the independence of lateralization measures (Marchant & McGrew, 1991), index scores were calculated again using maze duration data, and maze bout frequency data. Maze duration data were the total number of seconds each maze side was touched (Siniscalchi et al., 2012), and a bout was defined as a period of exploration of the maze, with separate bouts at least 2 min apart (Blois-Heulin et al., 2012). Z-scores were also calculated using these data. Two-sample Wilcoxon signed-rank tests were used to establish whether index values derived from frequency and duration data/bout frequency data were similar. One-sample Wilcoxon signed-rank tests were applied to index values to establish whether dolphin lateralization at the group level was significantly different from 0. In addition, a χ^2 tests were used to analyze the frequencies of when the ball was in the left and right side of the maze, frequencies of leftward and rightward ball movements, and the relationship between the maze side contacted and the location of the ball within the maze.

Results

There were no significant differences between median index values derived from frequency, duration data/bout frequency data (Bonferroni-corrected $p > 0.02$ in all tests); therefore frequency data were used for

further analyses. Table 2 summarizes individual dolphin eye lateralization and maze lateralization (side contacted and side pushed) during the baseline and challenge phase, using index and z -scores.

Table 2
Individual Dolphin Eye, Maze Side, and Maze Pushing Preferences During Baseline and Challenge Phases

Subject	Eye lateralization (derived from swimming rotation)					Maze side lateralization					Maze push lateralization				
	L	R	EL index	z	Overall	L	R	MSL index	z	Overall	L	R	MPL index	z	Overall
A															
Baseline	0	18	1.00	4.24*	R										
Challenge	2	16	0.78	3.30*	R	84	127	0.20	2.96*	R	50	48	-0.02	0.20	A
B															
Baseline	3	25	0.79	4.16*	R										
Challenge	0	23	1.00	4.80*	R	67	54	-0.11	1.82	A	23	31	0.15	0.27	A
C															
Baseline	3	26	0.79	4.20*	R										
Challenge	5	19	0.58	2.86*	R	14	13	-0.04	0.19	A	7	11	0.22	0.94	A
D															
Baseline	0	34	1.00	5.83*	R										
Challenge	4	11	0.33	1.81	A	3	0				0	1			
E															
Baseline	3	12	0.60	2.32*	R										
Challenge	4	12	0.50	2.00*	R	28	26	-0.04	0.27	A	16	23	0.18	1.12	A
F															
Baseline	0	22	1.00	4.69*	R										
Challenge	0	32	1.00	5.66*	R	7	28	0.60	3.55*	R	10	6	-0.25	1.00	A

Note. Subject D touched the maze a negligible amount and therefore has no index data in the maze columns. Overall classification refers to the significance of the z -score: R = right-lateralized, A = ambilateral.

* $p < 0.05$.

Eye Lateralization

All subjects had a strong counter-clockwise (i.e., left-turning) swimming rotation in the baseline phase, interpreted as strong right eye lateralization at individual level. The time spent with the right eye facing outwards ranged from 80 (Subject E) to 100% (Subjects A, D, F). The direction of lateralization was significantly different from 0 at the group level (EL index_{baseline} vs. 0: $Z = 2.23$, $p = 0.03$).

During the challenge phase, group level eye lateralization was significantly different from zero (EL index_{challenge} vs. 0: $Z = 2.21$, $p = 0.03$). The presence of the maze did not affect the individual bias (EL index_{baseline} vs. EL index_{challenge}: $Z = -1.36$, $p = 0.18$) as most dolphins (five subjects) remained significantly right-lateralized and just one (Subject D) was scored as ambilateral.

Maze Strategies

Figure 4 shows the maze being used by a Subject. There were two high-using dolphins who used the maze as follows: Subject A: 48% of contacts, Subject B: 23% of contacts. Dolphins used their rostrums to

make contact with the maze, they did not use their dorsal or pectoral fins. Nine hundred and fifty-six contacts were made in total across subjects. The most common problem-solving strategy (83%) was using the rostrum to push the maze horizontally (left/right) or vertically (up/down). The rarest problem-solving strategy was sliding their rostrum inside the pipe channel while the maze was static (2% of contacts). Moving the maze did not always move the ball (see Clark et al., 2013 for further details on problem-solving strategies).

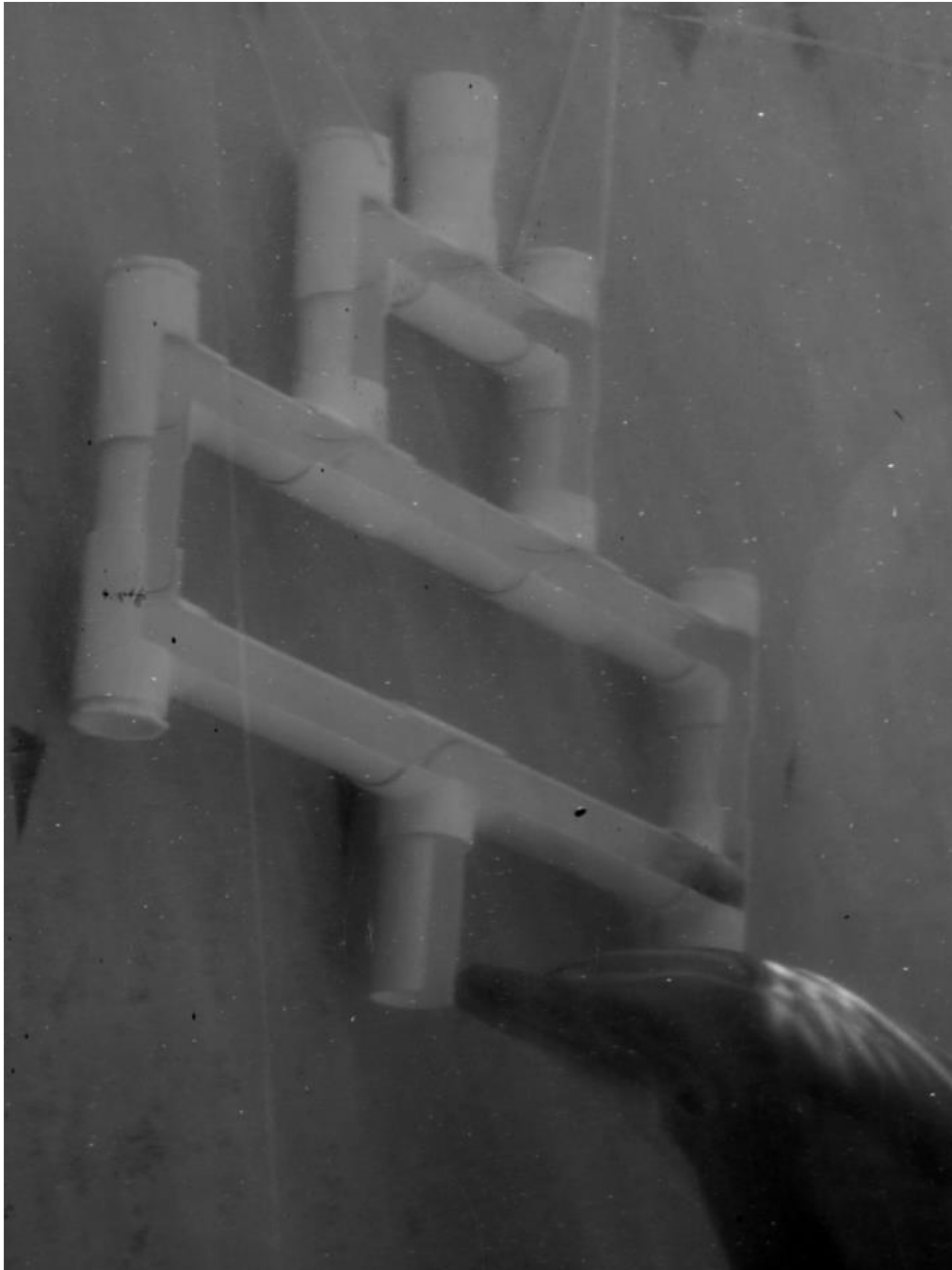

Figure 4. Maze being used by a subject (Subject A). Here, the ball is in the bottom right side of the maze and the dolphin is making contact to the exit pipe with its rostrum.

Maze Lateralization

Subjects A and F were significantly right-lateralized according to their z -scores, meaning that they used the right side of the maze significantly more than the left. Three subjects were ambilateral, and Subject D (the dominant male and oldest group member) was data deficient and was therefore excluded from analyses (see Table 1). It should be noted that Subjects A and B were the only two subjects to ‘solve’ the maze, nine and three times, respectively. Dolphins touched the middle of the maze 505 times over the course of the study (see Figure 3 for demarcated areas) which represented 505/956 contacts, 53%. At the group level, the MSL index was -0.1, indicating more contacts were made to the left side of the maze (55% left and 45% right) but this lateralization was weak and not significantly different from zero (MSL index vs. 0: $Z = -0.32$, $p = 0.75$). Baseline eye lateralization was significantly stronger than maze side lateralization (EL index_{baseline} vs. MSL index: $Z = -2.02$, $p = 0.04$); but eye lateralization when the maze was present was not significantly stronger than maze side lateralization (EL index_{challenge} vs. MSL index: $Z = -1.57$, $p = 0.12$).

All subjects were classified as having ambilateral maze pushing lateralization, except Subject D who was data deficient. Median (group level) MPL index direction was not significantly different from zero (MPL index vs. 0: $Z = 0.41$, $p = 0.69$). The relative leftward and rightward movement of the ball inside the maze (i.e., when we could clearly see the ball moving within the maze, as an effect of any strategy including pushing) was approximately equal (leftward: 13 events; rightward: 10 events), $\chi^2(1) = 0.39$, $p = 0.53$. A two-way χ^2 analysis revealed there was no relationship between the side of maze contacted, and the location of the ball within the maze, $\chi^2(1) = 2.79$, $p = 0.10$. However, the ball was significantly more in the left side of the maze (left: 161, right: 84), $\chi^2(1) = 24.20$, $p < 0.001$.

Discussion

This study represents the first known systematic effort to investigate lateralized behavior in dolphins in response to a bilaterally symmetrical underwater maze. This study contributes knowledge on cetacean lateralization, and should be the first step towards more comparative lateralization research. Four main results were revealed in the study. First, as predicted, dolphins at the group level were significantly left rotating (right-eyed) when swimming. Second, in support of the Information treatment modality hypothesis (Navon. 1977, 1981) and against the vertebrate-generalized Novelty hypothesis (Blois-Heulin et al., 2012), visual exploration of the maze by dolphins at the group level was favored by the right eye, indicating left brain hemisphere dominance for this task. Third, the majority of subjects failed to show a preference in which side of the maze was used; only two dolphins were significantly right-lateralized. Fourth, we found no support for the Task complexity hypothesis (Fagot & Vauclair, 1991), because the strength of lateralization in dolphins not significantly different in the challenge phase compared to baseline.

Eye Lateralization and the Information Treatment Hypothesis

As predicted, and in support of the Information treatment hypothesis, dolphins had a strong counter-clockwise (left-turning) swimming rotation. This was true at both the individual and group level. Other authors have reported strong left-turning swim patterns in captive cetaceans (Blois-Heulin et al., 2012; Ridgway, 1986; Sobel et al., 1994); placing the right eye towards the outside world (Blois-Heulin et al., 2012; Ridgway, 1986). The reason for a strong right eye lateralization in cetaceans, which goes against the general vertebrate pattern and Novelty hypothesis, is still not entirely clear. Our opinion is that body positioning in cetaceans is not a manifestation of brain lateralization as strongly as it appears to be in terrestrial vertebrates, due to additional

pressures of living in a three-dimensional aquatic world. For example, as stated in the introduction, the arrangement of organs within the body make right-acted feeding more preferable in cetaceans which creates a right side bias in their movement.

Eye lateralization was deduced from prevailing swimming rotation in our study because it was not possible to reliably score monocular eye use directly. Although subjects could be observed closely (within 5 m) from the underwater viewing windows, there was not a full 180° view of subjects using the maze. In future, the study could be replicated using a maze made from transparent plastic pipes placed up against an underwater viewing window. Cognitive task paradigms using transparent Perspex pipes are already established for corvids (e.g., Taylor, Hunt, Medina, & Gray, 2009) and great apes (e.g., Mulcahy & Call, 2006). This would allow more reliable recordings of dolphin head movements and body alignments in relation to the maze; and therefore more reliable inferences about which eye (if any) is preferentially used to view the maze. It would also be interesting from a cognitive cognition perspective. This methodological adjustment does not, however, solve the problem of calculating baseline eye preference when no maze is present. When dolphins interacted with ‘toys’ in their pool, they did so with their rostrums in a non-lateralized manner without an apparent pectoral fin or other side preference. In future, researchers could present an empty maze to dolphins to act as a baseline, then for the challenge phase present a maze that is still bilateral but has a different pattern than the baseline original.

Following the Task complexity hypothesis, we predicted that dolphin eye preference (derived from swimming rotation) would increase in strength when the maze was present. Against this prediction, it was found that the strength of eye lateralization decreased when the maze was present, but this was not significant. It was found in our parallel study (Clark et al., 2013) that circular swimming decreased when the maze was present because subjects spent more time being stationary using the maze. Even though subjects were familiar with ‘stationing’ against the pool wall to be trained and fed, the maze arguably placed more postural stress upon them because dolphins are not adapted to attend to static objects (animate or inanimate) in their environment. As discussed previously, the unique 3D aquatic environment of cetaceans presents unique lateralization challenges related to how the body is positioned in space, which then is likely to have an impact on how the brain is used, as well as vice versa.

Maze Use

Laboratory animals often develop a preference, over time, for using one side of a cognitive task more than the other. This phenomenon is usually overcome by repeating trials until the side bias has extinguished (e.g., chimpanzees: Seed, Call, Emery, & Clayton, 2009). In contrast, our study proposes that the manifestation of side biases could be a meaningful external representation of lateralized behavior. The maze we designed is particularly useful from this perspective because it has bilateral symmetry and therefore the array does not need counterbalancing over trials.

Dolphins usually approached the maze from the right side because of its position on the pool wall relative to their counter-clockwise swimming rotation around the pool. A lack of significant lateralization at the group level during the challenge phase suggests that dolphins did not just make passive contact with the maze as they swam past it; if this had been the case we would expect to see significant right lateralization. Although we do not have reliable data to confirm it, subjects appeared to approach the maze, stop, and re-align their bodies at the front center of the maze. Then they would make contact to either the left or right side. To investigate this positional behavior further, the current study design must be modified and we make three suggestions. First, in order to make more accurate measurements of the dolphin’s positional behavior once they

reach the maze, birds-eye view video footage should be taken. In order to counterbalance the position of the maze in relation to the prevailing swimming rotation, it could be placed on the opposite pool wall for 50% of trials. Alternatively could it be placed on a frame at the bottom center of the pool which should be affected by prevailing swimming rotation to a lesser extent. It could be possible that the two highest users (Subjects A and B) monopolized the maze and Subject A's significant right maze side lateralization may have forced other subjects to use the left maze side. However, we do not think that social displacement was likely because maze use was primarily a lone activity (Clark et al., 2013).

Ambilateral animals could have an advantage over significantly lateralized animals, and thus the lack of group level significant lateralization during the challenge phase could indicate that dolphins are proactive problem-solvers. Marshall-Pescini, Colombo, Passalacqua, Merola, and Prato-Previde (2013) found that ambilaterally pawed domestic dogs were faster at solving a food-based manipulative task. To further this line of enquiry we suggest a far larger sample size of dolphins is required and other methods are used to measure 'baseline' lateralization, such as an empty maze, as suggested above.

It is necessary to consider reward location when discussing these results, because this may bias where and how subjects choose to contact the maze. It was possible to track the ball location on video footage, and there was no significant relationship between ball location and the side of maze contacted. This being said, the data show that the ball was in the left side of maze significantly more often than the right. We encourage future research on a fully static maze, to encourage more use of the rostrum to slide the ball left or right, although this behavior was rare and we anticipate more trials would be needed for dolphins to become familiar with this strategy. This is important since lateralization of the rostrum as an unpaired appendage has not been studied well. Interesting comparisons could perhaps be made to birds such as Charadriiformes who load prey into their beaks in a lateralized manner (Grace & Craig, 2008), tail-wagging in dogs (Quaranta et al., 2007), or trunk lateralization in Asian elephants (Haakonsson & Semple, 2009).

To close, we discuss a number of further areas for research. First, our study subjects were tested in their normal social group, and it would be naïve to suggest that individuals were not influenced by observing their conspecifics on the task. However, isolating socially housed animals can be stressful and testing individuals on a similar maze is better suited to a laboratory setting where animals are familiar with periods of isolation. Our maze was only studied over a two-week period and therefore remained 'novel'; changes to lateralization as the maze becomes more familiar over time may be observed. And finally, we acknowledge that echolocation is a major cognitive skill in dolphins in the underwater realm, and it would be interesting to examine lateralized behavior when echolocation cannot be used. To this end, we suggest the 'black box' approach of Herman and colleagues (e.g., Herman, Pack, & Hoffmann-Kuhnt, 1998; see review by Au, 1993), there stimuli are placed underwater in black boxes which occludes the visual sense.

References

- Altmann, J. (1974). Observational studies of behavior: Sampling methods. *Behaviour*, 49, 227–267.
- Annett, M. (2002). *Handedness and brain asymmetry: The right shift theory*. London, UK: Psychology Press.
- Au, W. W. L. (1993). *The sonar of dolphins*. New York, NY: Springer-Verlag.
- Blois-Heulin, C., Crével, M., Böye, M., & Lemasson, A. (2012). Visual laterality in dolphins: Importance of the familiarity of stimuli. *BMC Neuroscience*, 13, 1–8.
- Braccini, S. N., Lambeth, S. P., Schapiro, S. J., & Fitch, W. T. (2012). Eye preferences in captive chimpanzees. *Animal Cognition*, 15, 1–8.
- Clark, F. E., Davies, S. L., Madigan, A. W., Warner, A. J., & Kuczaj, S. A. (2013). Cognitive enrichment for bottlenose dolphins (*Tursiops truncatus*): Evaluation of a novel underwater maze device. *Zoo Biology*, 32, 608–619.

- Cranford, T. W., Amundin, M., & Norris, K. S. (1996). Functional morphology and homology in the odontocete nasal complex: Implications for sound generation. *Journal of Morphology*, 228, 223–285.
- Csermely, D., & Regolin, L. (2013). *Behavioral lateralization in vertebrates*. New York, NY: Springer.
- Davidson, R. J. (1992). Emotion and affective style: Hemispheric substrates. *Psychological Science*, 3, 39–43.
- Davidson, R. J. (1995). Cerebral asymmetry, emotion, and affective style. In R. J. Davidson & K. Hugdahl. (Eds.), *Brain asymmetry* (pp. 361–387). Cambridge, MA: MIT Press.
- De Boyer Des Roches, A., Richard-Yris, M. A., Henry, S., Ezzaoui, M., & Hausberger, M. (2008). Laterality and emotions: Visual laterality in the domestic horse (*Equus caballus*) differs with objects' emotional value. *Physiology & Behavior*, 94, 487–490.
- de Waal, F. B. M. (2005). A century of getting to know the chimpanzee. *Nature*, 437, 56–59.
- Delfour, F., & Marten, K. (2006). Lateralized visual behavior in bottlenose dolphins (*Tursiops truncatus*) performing audio-visual tasks: The right visual field advantage. *Behavioural Processes*, 71, 41–50.
- Fagot, J., & Vauclair, J. (1991). Laterality in nonhuman primates: A distinction between handedness and manual specialization. *Psychological Bulletin*, 109, 76–89.
- Galatius, A., & Jespersen, A. (2005). Bilateral directional asymmetry of the appendicular skeleton of the harbor porpoise (*Phocoena phocoena*). *Marine Mammal Science*, 21, 401–410.
- Galatius, A. (2006). Bilateral directional asymmetry of the appendicular skeleton of the white-beaked dolphin (*Lagenorhynchus albirostris*). *Aquatic Mammals*, 32, 232–235.
- Gómez-Campos, E., Aguilar, A., & Goodall, R. N. P. (2010). Serrated flippers and directional asymmetry in the appendicular skeleton of the Commerson's dolphin (*Cephalorhynchus commersonii*). *Anatomical Record*, 293, 1816–1824.
- Grace, J., & Craig, D. P. (2008). The development and lateralization of prey delivery in a bill load-holding bird. *Animal Behaviour*, 75, 2005–2011.
- Haakonsson, J. E., & Semple, S. (2009). Lateralisation of trunk movements in captive Asian elephants (*Elephas maximus*). *Laterality*, 14, 413–422.
- Herman, L. M., Pack, A. A., & Hoffmann-Kuhnt, M. (1998). Seeing through sound: Dolphins (*Tursiops truncatus*) perceive the spatial structure of objects through echolocation. *Journal of Comparative Psychology*, 112, 292.
- Holobinko, A., & Waring, G. H. (2010). Conflict and reconciliation behavior trends of the bottlenose dolphin (*Tursiops truncatus*). *Zoo Biology*, 29, 567–585.
- Hopkins, W. D., Tagliatalata, J., Leavens, D.A., Russell, J. L., & Schapiro, S. J. (2010). Behavioural and brain asymmetries in chimpanzees. In E. V. Lonsdorf, S. R. Ross, & T. Matsuzawa (Eds.), *The Mind of the chimpanzee: Ecological and experimental perspectives* (pp. 60–74). Chicago, IL: The University of Chicago Press.
- Johnson, C. M., & Moewe, K. (1999). Pectoral fin preference during contact in Commerson's dolphins (*Cephalorhynchus commersonii*). *Aquatic Mammals*, 25, 73–77.
- Karenina, K., Giljov, A., Baranov, V., Osipova, L., Krasnova, V., & Malashichev, Y. (2010). Visual laterality of calf-mother interactions in wild whales. *PLoS ONE*, 5, e13787.
- Karenina, K., Giljov, A., Ivkovich, T., & Malashichev, Y. (2016). Evidence for the perceptual origin of right-sided feeding biases in cetaceans. *Animal Cognition*, 19, 239–243.
- Kilian, A., von Fersen, L., & Güntürkün, O. (2000). Lateralization of visuospatial processing in the bottlenose dolphin (*Tursiops truncatus*). *Behavioural Brain Research*, 116, 211–215.
- Kilian, A., von Fersen, L., & Güntürkün, O. (2005). Left hemisphere advantage for numerical abilities in the bottlenose dolphin. *Behavioural Processes*, 68, 179–184.
- Laska, M. (1998). Laterality in the use of the prehensile tail in the spider monkey (*Ateles geoffroyi*). *Cortex*, 34, 123–130.
- Lilak, A. L., & Phillips, K. A. (2008). Consistency of hand preference across low-level and high-level tasks in Capuchin monkeys (*Cebus apella*). *American Journal of Primatology*, 70, 254–260.
- Llorente, M., Riba, D., Palou, L., Carrasco, L., Mosquera, M., Colell, M., & Feliu, O. (2011). Population-level right-handedness for a coordinated bimanual task in naturalistic housed chimpanzees: replication and extension in 114 animals from Zambia and Spain. *American Journal of Primatology*, 73, 281–290.
- MacLeod, C. D., Reidenberg, J. S., Weller, M., Santos, M. B., Herman, J., Goold, J., & Pierce, G. J. (2007). Breaking symmetry: The marine environment, prey size, and the evolution of asymmetry in cetacean skulls. *Anatomical Record*, 290, 539–545.

- MacNeilage, P. F. (2014). Evolution of the strongest vertebrate rightward action asymmetries: Marine mammal sidedness and human handedness. *Psychological Bulletin*, *140*, 587.
- MacNeilage, P. F., Rogers, L., & Vallortigara, G. (2009). Origins of the left and right brain. *Scientific American*, *301*, 60–67.
- Marchant, L. F., & McGrew, W. C. (1991). Laterality of function in apes: A meta-analysis of methods. *Journal of Human Evolution*, *21*, 425–438.
- Marino, L., & Stowe, J. (1997). Lateralized behavior in two captive bottlenose dolphins (*Tursiops truncatus*). *Zoo Biology*, *16*, 173–177.
- Marshall-Pescini, S., Colombo, E., Passalacqua, C., Merola, I., & Prato-Previde, E. (2013). Gaze alternation in dogs and toddlers in an unsolvable task: Evidence of an audience effect. *Animal Cognition*, *16*, 933–943.
- Martin, P., & Bateson, P. (2007). *Measuring behaviour: An introductory guide*. Cambridge: Cambridge University Press.
- Mosquera, M., Llorente, M., Riba, D., Estebanz, F., González-Brao, M., Lorenzo, C., & Feliu, O. (2007). Ethological study of manual laterality in naturalistic housed chimpanzees (*Pan troglodytes*) from the Mona Foundation Sanctuary (Girona, Spain). *Laterality*, *12*, 19–30.
- Mulcahy, N. J., & Call, J. (2006). How great apes perform on a modified trap-tube task. *Animal Cognition*, *9*, 193–199.
- Navon, D. (1977). Forest before trees: The precedence of global features in visual perception. *Cognitive Psychology*, *9*, 353–383.
- Navon, D. (1981). Do attention and decision follow perception? Comment on Miller. *Journal of Experimental Psychology: Human Perception and Performance*, *7*, 1175–1182.
- Ness, A. R. (1967). A measure of the asymmetry of the skulls of odontocete whales. *Journal of Zoology, London*, *153*, 209–221.
- Prost, J. H. (1965). A definitional system for the classification of primate locomotion. *American Anthropologist*, *67*, 1198–1214.
- Quaranta, A., Siniscalchi, M., & Vallortigara, G. (2007). Asymmetric tail-wagging responses by dogs to different emotive stimuli. *Current Biology*, *17*, R199–R201.
- Ridgway, S. H. (1972). Homeostasis in the aquatic environment. In S. Ridgway (Ed.), *Mammals of the sea* (pp. 590–747). Springfield, IL: Thomas Publishing.
- Ridgway, S. H. (1986). Physiological observations on the dolphin brain. In R. J. Schusterman, J. A. Thomas, & F. Wood (Eds.), *Dolphin cognition and behavior: A comparative approach* (pp. 31–60). New Jersey, NY: Erlbaum.
- Rogers, L. J. (2009). Hand and paw preferences in relation to the lateralized brain. *Philosophical Transactions of the Royal Society of London B: Biological Sciences*, *364*, 943–954.
- Rogers, L. J. (2010). Relevance of brain and behavioural lateralization to animal welfare. *Applied Animal Behaviour Science*, *127*, 1–11.
- Rogers, L. J., & Andrew, R. J. (2002). *Comparative vertebrate lateralization*. Cambridge, England: Cambridge University Press.
- Sakai, M., Hishii, T., Takeda, S., & Kohshima, S. (2006). Laterality of flipper rubbing behavior in wild bottleneck dolphins (*Tursiops aduncus*): Caused by asymmetry of eye use?. *Behavioural Brain Research*, *170*, 204–210.
- Schweitzer, C., Bec, P., & Blois-Heulin, C. (2007). Does the complexity of the task influence manual laterality in De Brazza's monkeys (*Cercopithecus neglectus*)?. *Ethology*, *113*, 983–994.
- Seed, A. M., Call, J., Emery, N. J., & Clayton, N. S. (2009). Chimpanzees solve the trap problem when the confound of tool-use is removed. *Journal of Experimental Psychology: Animal Behavior Processes*, *35*, 23–34.
- Siniscalchi, M., Dimatteo, S., Pepe, A. M., Sasso, R., & Quaranta, A. (2012). Visual lateralization in wild striped dolphins (*Stenella coeruleoalba*) in response to stimuli with different degrees of familiarity. *PLoS ONE*, *7*, e30001.
- Sobel, N., Supin, A. Y., & Myslobodsky, M. S. (1994). Rotational swimming tendencies in the dolphin (*Tursiops truncatus*). *Behavioural Brain Research*, *65*, 41–45.
- Stafne, G. M., & Manger, P. R. (2004). Predominance of clockwise swimming during rest in Southern Hemisphere dolphins. *Physiology & Behavior*, *82*, 919–926.
- Taylor, A. H., Hunt, G. R., Medina, F. S., & Gray, R. D. (2009). Do new Caledonian crows solve physical problems through causal reasoning? *Proceedings of the Royal Society of London B: Biological Sciences*, *276(1655)*, 247–254.
- Thieltges, H., Lemasson, A., Kuczaj, S., Böye, M., & Blois-Heulin, C. (2011). Visual laterality in dolphins when looking at (un)familiar humans. *Animal Cognition*, *14*, 303–308.

- von Fersen, L., Schall, U., & Güntürkün, O. (2000). Visual lateralization of pattern discrimination in the bottlenose dolphin (*Tursiops truncatus*). *Behavioural Brain Research*, *107*, 177–181.
- Ward, J. P., & Hopkins, W. D. (1993). *Primate laterality: Current behavioral evidence of primate asymmetries*. New York, NY: Springer Verlag.
- Yaman, S., von Fersen, L., Dehnhardt, G., & Güntürkün, O. (2003). Visual lateralization in the bottlenose dolphin (*Tursiops truncatus*): Evidence for a population asymmetry?. *Behavioural Brain Research*, *142*, 109–114.
- Yeater, D. B., Hill, H. M., Baus, N., Farnell, H., & Kuczaj II, S. A. (2014). Visual laterality in belugas (*Delphinapterus leucas*) and Pacific white-sided dolphins (*Lagenorhynchus obliquidens*) when viewing familiar and unfamiliar humans. *Animal Cognition*, *17*, 1245–1259.

Submitted: August 14th, 2016

Resubmitted: October 15th, 2016

Accepted: October 20th, 2016