

# Lawrence Berkeley National Laboratory

## Recent Work

### Title

LOW-DENSITY POLYURETHANE FOAM PLATE SPARK CHAMBER

### Permalink

<https://escholarship.org/uc/item/46z669t3>

### Authors

Schnurmacher, Gerald L.

Clark, Alan R.

Kerth, Leroy T.

### Publication Date

1967-11-02

**University of California**  
**Ernest O. Lawrence**  
**Radiation Laboratory**

LOW-DENSITY POLYURETHANE FOAM PLATE  
SPARK CHAMBER

Gerald L. Schnurmacher, Alan R. Clark, and Leroy T. Kerth

November 2, 1967

Berkeley, California

## **DISCLAIMER**

This document was prepared as an account of work sponsored by the United States Government. While this document is believed to contain correct information, neither the United States Government nor any agency thereof, nor the Regents of the University of California, nor any of their employees, makes any warranty, express or implied, or assumes any legal responsibility for the accuracy, completeness, or usefulness of any information, apparatus, product, or process disclosed, or represents that its use would not infringe privately owned rights. Reference herein to any specific commercial product, process, or service by its trade name, trademark, manufacturer, or otherwise, does not necessarily constitute or imply its endorsement, recommendation, or favoring by the United States Government or any agency thereof, or the Regents of the University of California. The views and opinions of authors expressed herein do not necessarily state or reflect those of the United States Government or any agency thereof or the Regents of the University of California.

UCRL-17947  
c.2 repl.

# University of California

## Ernest O. Lawrence Radiation Laboratory

LOW-DENSITY POLYURETHANE FOAM PLATE  
SPARK CHAMBER

Gerald L. Schnurmacher, Alan R. Clark, and Leroy T. Kerth

November 2, 1967

**TWO-WEEK LOAN COPY**  
*This is a Library Circulating Copy  
which may be borrowed for two weeks.*

Berkeley, California

UCRL-17947  
c.2 repl.

Submitted to Nucl. Instr. Methods

UCRL-17947  
Preprint

UNIVERSITY OF CALIFORNIA

Lawrence Radiation Laboratory  
Berkeley, California

AEC Contract No. W-7405-eng-48

LOW-DENSITY POLYURETHANE FOAM PLATE  
SPARK CHAMBER

Gerald L. Schnurmacher, Alan R. Clark, and Leroy T. Kerth

November 2, 1967

LOW-DENSITY POLYURETHANE FOAM PLATE  
SPARK CHAMBER

Gerald L. Schnurmacher, Alan R. Clark, and Leroy T. Kerth

Lawrence Radiation Laboratory  
University of California  
Berkeley, California

November 2, 1967

Abstract

Development of a multi-gap, low-density visual spark chamber is described. The design has been used successfully to make spark chambers up to 2600 in.<sup>2</sup> in area with very uniform gap spacing. Individual plate thickness is approximately 0.125 in. Density per plate is approximately 29 mg/cc, or the radiation length equivalent to approximately 2 mils of aluminum. The chambers have been pulsed in a Bevatron experiment over  $2.5 \times 10^6$  times with good efficiency.

## 1. Introduction

Many variations of low-density spark chamber plates have been developed over the past few years. The most common technique for making large-area low-density plates is to stretch aluminum foil over an electrically conducting picture frame and enclose the plate array in a gas box. When fabricating this type of spark chamber electrode a mechanical stretching device is generally utilized to stretch the aluminum foil over the metallic picture frame, which may or may not be prestressed. Gap spacing between plates in the chamber is accomplished by using supplementary insulators. Since the supporting picture frames in this type of chamber must be strong enough to keep the foil stretched, they are usually bulky and heavy; hence, this technique is only suitable for chambers used in experiments where the physical size and density of the supporting frames are not a critical parameter.

## 2. Polyurethane Foam as a Material for Spark Chamber Plates

Spark chamber plates of the type described herein are made by affixing foil with epoxy to both sides of a sheet of polyurethane foam surrounded by an aluminum frame of the same thickness (see Fig. 1). The plates are then alternated with Lucite picture frames to which they are affixed with epoxy. These Lucite frames serve as plate separators, gas barriers, and optical windows. Since the foils are uniformly supported over their entire area, rather than stretched over a perimeter frame, the aluminum frame surrounding the polyurethane core can be made considerably lighter or, if the experiment demands, eliminated. As a result of total uniform foil support, maximum size of the electrodes

can be increased without sacrificing rigidity, but still maintaining low plate density. Since individual plates are only approximately 0.125 in. thick, total spark chamber thickness along the beam axis can be kept small, which may be an advantage in experiments having a confining geometry.

The aluminum picture frame or partial frame, where the experimental parameters require its use, facilitates making electrical connections to the electrodes as well as increasing plate rigidity and allowing the use of a sandwich construction, with alternating optical picture frames and spark chamber plates. If this sandwich construction technique is used without the aluminum picture frame surrounding the foam core, the individual plates can be easily damaged due to core compression, and this results in edge sparking.

The use of polyurethane foam as a core material for spark chamber plates was first described by Bernstein et al.;<sup>1</sup> however, the chambers discussed herein utilize a specially developed polyurethane foam with different chemical properties from that previously described, and this material offers distinct advantages over the original foam, as will be discussed. There are other design differences between the chambers described herein and those of Bernstein et al.,<sup>1</sup> but these parameters vary depending on the experiment in which the chambers are used.

Several types of material were tried as cores for the aluminum picture frames. The various types of polyurethane foam that were tried that fulfilled the low-density requirement were found to not work at all in a completed chamber unless high clearing fields, on the order of several hundred volts, were used. Even then, many spurious sparks



formed when the chamber was pulsed, and performance was far from ideal. Since the final chambers were to be used in a magnetic field of approximately 17 kilogauss, it was undesirable to use large clearing fields because of the resultant displacement of the sparks from the particle trajectories. Investigation of the manufacturing process of polyurethane foam revealed the use of Freon-11 as the foaming agent. Individual cells of polyurethane foam are formed by raising the temperature of the unpolymerized chemical mixture to the boiling point of Freon (28°C) and then bringing on polymerization while the bubbles are formed. Each semipermeable Freon-filled bubble in the foam has a wall thickness of a fraction of a mil, and is extremely susceptible to rupture. The polyurethane cores therefore represented an infinite source of Freon. Freon-11 which leaked into the spark chamber due to outgassing of the polyurethane core has a strong affinity for electrons, coupled with a low detachment voltage. Therefore, the electrons captured by the Freon are released when the high-voltage pulse is applied to the chamber, resulting in spurious sparks.

Various techniques of eliminating the Freon in the surface layer of cells were tried, such as using a combination of elevated temperature and vacuum and bringing the plates up to atmospheric pressure in an argon environment. Successive quantitative gas analyses continually indicated the presence of several parts per million of Freon-11 in the neon-helium atmosphere of the completed chambers. A microscopic analysis of the aluminum foil skin that covered the foam plate core and served as the electrode material indicated it had random permeability due to microscopic holes. In order to minimize density, 0.0005-in. -thick

aluminum had been selected to cover the frame and core and serve as the electrode material. The foil used was 1100 alloy H-19 temper. In order to preserve low density in the useful area of the chamber, it was decided to retain this type of foil and search for an alternative type of core. In some experiments in which plate density is not a critical parameter, it is possible to use the standard Freon foam covered with 1- or 2-mil aluminum foil, which serves as an effective barrier to Freon outgassing from the core and diffusing into the spark chamber.

The Freon contamination problem was solved by having special polyurethane foam manufactured by General Plastics Manufacturing Company of Tacoma, Washington, in which a straight-chain hydrocarbon, butane-2-methyl (isopentane), was substituted for Freon-11. Isopentane has physical properties similar to Freon-11 and boils at approximately the same temperature. It therefore proved to be compatible with the polyurethane foam manufacturing technique, and the physical properties of this special foam were comparable to that made with Freon. Since the isopentane foam has no electronegative components and very low density, it is an excellent core material, and a moderate amount of contamination of the spark chamber gas with isopentane has no deleterious effects.

### 3. Design and Fabrication

The foam core material was purchased in thin sheets slightly oversize in all dimensions. The final length and width dimensions are obtained by trimming the sheets with a razor blade. The sheets are reduced to their final 0.125-in. thickness by running them through a simple surface grinding machine which utilizes a single abrasive roller

the width of the foam sheet. This method produces uniformly thick plates to 2-mil tolerance, and is similar to the technique used by Bernstein et al.<sup>1</sup> to produce a Freon foam plate spark chamber in which the edges of the plates are unsupported.

The isopentane polyurethane foam described herein was used in conjunction with an aluminum picture frame, Figs. 1 and 2, made from 0.125-in.-thick aluminum alloy sheet of moderately hard temper such as 6061-T6. The inside area of the aluminum sheet is cut out with a band-saw so that a picture frame is left having inside and outside dimensions 1/8 in. less than the inside and outside dimension of the Lucite optical window frame in both the length and width dimensions (see Fig. 1). The edges of the frame are suitably drilled for electrical connections.

To assemble the plate components, two sheets of 1-in.-thick aluminum tool and jig stock, which had been surface ground so they were uniformly flat to very small tolerance, were used. The jig plate should be approximately 8 in. longer and wider than the aluminum picture frames to be used. One side of each jig plate should be covered with 1-mil-thick Mylar, which is peripherally taped to the jig plate.

The foam core, after being reduced to size in all dimensions, should be fastened inside the aluminum frame by using an adhesive mixture, painted on the inside edges of the aluminum frame, composed of 50% Versamid 125 and 50% of a mixture made from 70% Shell 826 epoxy and 30% Shell 736 epoxy. This should be allowed to cure for approximately 24 hours. 1100-H19 aluminum foil, 0.0005 in. thick and equal in area to the jig plate, should then be stretched by hand over each jig plate and taped to the jig plates at their edges. Tension can be

locally adjusted by gentle hand pulling on the tape attached to the edge of the foil until all wrinkles are eliminated. An extremely thin uniform coat of 50% Versamid 125 and 50% of a mixture made from 70% Shell epoxy 826 and 30% Shell epoxy 736 is then applied to the surface of each stretched foil by using a fine-grain polyurethane foam-type paint roller such as is commonly used in the home. It was subsequently found desirable to incorporate 3% toluene into the mixture, as this tended to thin the adhesive further. After the adhesive is rolled onto the foil, it should be allowed to stand for approximately 45 minutes until the toluene has evaporated. This leaves a thinner film of viscous adhesive than would have been possible if a nonsolvent evaporative thinning agent had been used. The epoxy 736 also serves to thin the mixture. The aluminum frame—polyurethane core assembly then should be placed so it is centered on top of one of the foil-covered jig plates. The second foil-covered jig plate is then placed, foil side down, on the exposed core side of the spark chamber plate. It was found to be beneficial to add approximately 1/4 to 3/4 pounds of weight per square inch nonuniformly distributed on top of the upper jig plate. This was accomplished by cutting up lead bricks and placing a layer of the pieces on top of the jig plate with the greatest weight in the center and diminishing towards the edges. The resultant sandwich should then be left to cure for approximately 24 hours. At the end of this period, the tape holding the foil to the jig plates should be cut with a razor blade and the jig plates should be carefully removed. Infrequently, a minute quantity of epoxy may come through the foil; however, it does not adhere to the Mylar that shields the jig plate. The foil should then be carefully trimmed from the outer

edge of the aluminum picture frame except in the area where the electrical connection is to be made, and there it should be folded over the edge of the frame so it overlaps it and then be trimmed (see Fig. 2).

The Lucite picture frames, which serve as plate separators and optical windows (Figs. 1 and 2), are made with dimensions  $1/8$  in. greater than the inside and outside dimensions of the aluminum picture frame described above. This creates  $1/16$ -in. -deep channels around the periphery of the spark chamber formed by optical sandwiches overlapping spark chamber plates (see Fig. 1). This channel in final assembly is filled with epoxy which acts both as a "mechanical clamp" and an insulator for the edges of each of the high voltage spark chamber plates.

The optical-window picture frame is made from  $1/2$ -in. -wide strips of class II, UVA, industrial grade unshrunk Lucite. The Lucite strips are cut from  $1/2$ -in.  $\times$  4  $\times$  8-ft sheet stock, by use of a rotary table saw. The  $1/2$ -in. stock dimension is preserved for optical viewing and individual strips are rejected if measurements indicate an average variation in optical thickness greater than 0.001 in. per lineal inch of strip. These strips are cut  $7/16$  in. wide on the saw and then are stress-relieved in an oven. Final machining is done with coolant on an automated milling machine to reduce the thickness in the saw-cut dimension from  $7/16$  in. to  $0.375 \pm 0.001$  in. The strips in the machined dimension provide uniform gap spacing in the chamber along the beam axis. The Lucite strips are finally held together by making corner butt joints, using Cadillac PS-18 adhesive. In gluing the joints, great care should be taken to eliminate air bubbles, which are sources of corona discharge when the chamber is pulsed. The frames are suitably drilled for gas manifolds, both input and exhaust.

After the necessary numbers of plates and Lucite frames have been fabricated, they are assembled to form the completed chamber. A 50% - 50% mixture of Ciba 502 and Versamid 125 is used and applied to each side of a Lucite frame, which then is positioned over a spark chamber plate in such a way that there is a peripheral overlap of 1/16 in. When the desired number of plates and Lucite frames has been assembled, the stack is peripherally loaded with small lead bricks and allowed to cure for 24 hours. Figure 2 shows the electrical connection tabs, which are screwed through the overlapped foil and into the aluminum frame. The tabs facilitate good electrical connection and eliminate the undesirable feature of electrically pulsing the chamber through a film of epoxy. The 1/16-in. -deep channels formed by the overlap of the Lucite frames and the plates should be filled with a viscous epoxy of high dielectric strength and left to cure. Ciba 502 with curing agent U was used for this purpose. The final step in assembly is the placing of the Mylar windows over the outer buffer gaps. The Mylar is held to the Lucite frame with double-backed scotch tape, and 1-in. -wide Mylar tape is used over the edge (Fig. 1).

---

This completes the assembly, and the spark chamber is then ready for use.

Gas manifolding for each gap should always be done in parallel and never in series, to avoid buckling the plates as a result of possible differential gap pressure.

An experiment currently being set up at the LRL Bevatron uses isopentane foam plate spark chambers, in which the plates have aluminum support frames on only three edges. The foam core on the unsupported

side is radiused, and the entire surface of each plate, including frame, is covered by a continuous piece of foil. A thin sheet of acrylic, perpendicular to the plates, is glued to the foil on the unsupported radiused edge and acts as an optical window as well as a gas barrier. These chambers operate efficiently at 14 to 15 kV, and in tests no edge sparking was evident at voltages to 17 kV.<sup>2</sup>

Spark chambers similar to those described herein using isopentane foam were recently used with success in a SLAC experiment, and others are being currently used by visiting experimenters at the Bevatron.

#### 4. Conclusions

The resulting density of the foam-foil area of the spark chamber plates is approximately 29 mg/cc, or the radiation length equivalent to approximately 2 mils of aluminum. The overall weight of such a chamber is exceptionally low, eliminating the need for complex or bulky structural support in an experiment. A typical four-gap 1.5×5.5-ft chamber weighs approximately 20 pounds. Since fabrication time and complexity are kept to a minimum and all materials used are inexpensive, the resultant cost for this type of chamber is considerably less than for a comparable size of aluminum-framed hollow plate chamber. The use of the polyurethane core also minimizes the need for a dense perimeter support structure, which may be an advantage in geometry-limited experiments.

5. Acknowledgments

The authors wish to thank Mr. Thomas Brazier of General Plastics Manufacturing Company of Tacoma, Washington, without whose cooperation the isopentane-fabricated polyurethane foam would not have been available, and Dr. Arthur Roberts for conversations regarding his technique for low-density plate construction as described in the literature. Mr. Jim Byce of the Mechanical Technician Shop at LRL also contributed to the final development of the fabrication technique.



References

\*Work done under auspices of the U. S. Atomic Energy Commission.

1. S. Bernstein et al., I. E. E. E. Transactions on Nucl. Sci. 12 [4],  
120 (1965).

2. D. Newton and J. F. McReynolds (Lawrence Radiation Laboratory),  
private communication.

FIGURE LEGENDS

Fig. 1. Expanded cross section of spark chamber plate and electrical connection tab.

Fig. 2. Expanded cross section of spark chamber assembly.

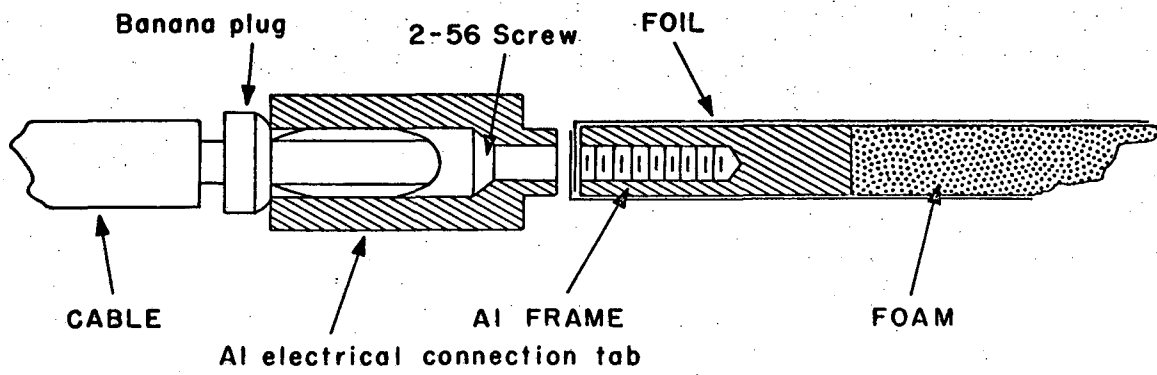

Fig. 1

XBL6711-5679

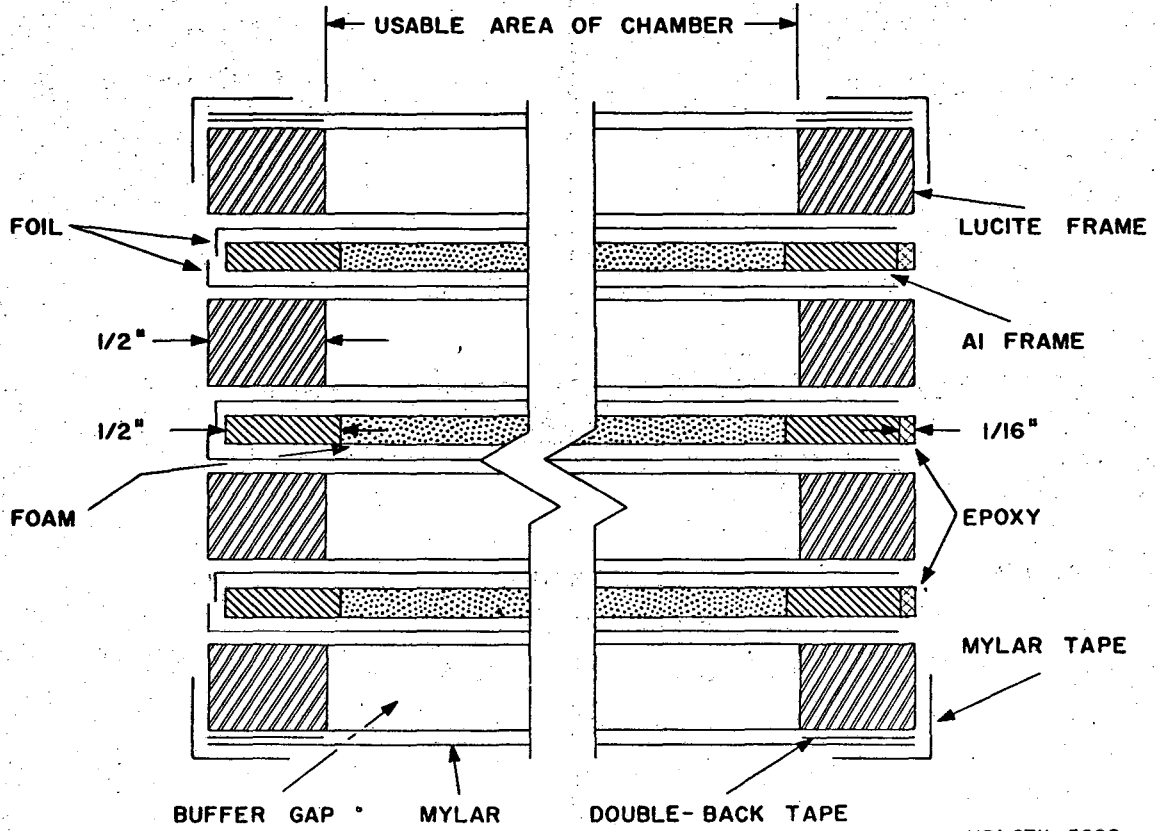

Fig. 2

XBL6711-5680

This report was prepared as an account of Government sponsored work. Neither the United States, nor the Commission, nor any person acting on behalf of the Commission:

- A. Makes any warranty or representation, expressed or implied, with respect to the accuracy, completeness, or usefulness of the information contained in this report, or that the use of any information, apparatus, method, or process disclosed in this report may not infringe privately owned rights; or
- B. Assumes any liabilities with respect to the use of, or for damages resulting from the use of any information, apparatus, method, or process disclosed in this report.

As used in the above, "person acting on behalf of the Commission" includes any employee or contractor of the Commission, or employee of such contractor, to the extent that such employee or contractor of the Commission, or employee of such contractor prepares, disseminates, or provides access to, any information pursuant to his employment or contract with the Commission, or his employment with such contractor.

[The page contains extremely faint, illegible text that appears to be bleed-through from the reverse side of the document. The text is too light to transcribe accurately.]

