

UCLA
Contemporary Music Score Collection

Title

Leviathan

Permalink

<https://escholarship.org/uc/item/45r2k4ds>

Author

Rojas, Angeles

Publication Date

2020

Copyright Information

This work is made available under the terms of a Creative Commons Attribution License, available at <https://creativecommons.org/licenses/by/4.0/>

ANGELES ROJAS

LEVIATHAN (2016)

FOR CHAMBER ENSEMBLE

Instrumentation

BASS CLARINET [B. CL.]

DIDGERIDOO [D.D.]

VIOLIN [VIN.]

CELLO [VIC.]

PIANO [PNO.]

PERCUSSION

TRIANGLE [TRPL.]*

BASS DRUM [B. DR.]

BASS CLARINET IS WRITTEN WITH FRENCH NOTATION

THERE ARE A LOT OF PPP AND INTIMATE SOUNDS. THE USE OF MICROPHONES IN THESE CASES ARE OPTIONAL BUT I PREFER NOT TO USE THEM.

THERE ARE VIDEO LINKS THAT SHOWS SOME OF THE EXTENDED TECHNIQUES. EX = [PNO1] FOR ONE EFFECT OF THE PIANO.

IN THE WHOLE PIECE I USE A LOT OF EFFECTS WITH THE INFERBOWL. IN SOME CASES YOU CAN CONTROL DYNAMICS BY THE VELOCITY OF THE MOVEMENT, BUT, IN OTHER CASES IT'S IMPOSSIBLE. THAT'S WHY IN N° III I DECIDED NOT TO INDICATE THEM.

* TRY TO USE A SMALL TRIANGLE (4 in.) WITH A THINNEN BEATER.

Performance notes

= MUTE INSTRUMENT

= LOWEST AND HIGHEST NOTE.

= JUST AIR

= APPROXIMATE PITCH

= INHALE.

= EXHALE.

FRULL. = FRULLATO.

grull. = GRULLATO.

S.V. = SENZA VIBRATO

VIB. = VIBRATO.

ORD. = ORDINARY.

M.S.P. = MOLTO SU PONTICELLO.

= BEHIND THE BRIDGE.

= PEDAL NOISE.

= PLAY AS FAST AS POSSIBLE.

= RITARDANDO.

= ACCELERANDO.

= INSIDE THE PIANO

= PLAY WITH SUPENBOWL Mallet.

W/STICK = PLAY WITH THE STICK OF THE Mallet.

O = PLAY WITH A RING. PNO.3

= PLAY WITH A MEDIUM, SOFT BRUSH.

= PLAY WITH A SMALL, HARD BRUSH.

= PLAY ON THE BACK OF THE INSTRUMENT. VIC.1

FALL BOARD = PLAY WITH THE SUPENBOWL ON THE CLOSED PIANO FALL BOARD. PNO.4

ANGLE OF FALL BOARD = PLAY WITH THE SUPENBOWL ON THE ANGLE OF THE CLOSED PIANO FALL BOARD. PNO.4

RESONATION PATCH = PLAY WITH THE SUPENBOWL ON THE RESONATION PATCH. B.DR.1

PATCH = PLAY WITH THE SUPENBOWL ON THE ORDINARY PATCH. B.DR.2

= PLAY WITH THE SUPENBOWL ON STRINGS, VERY SLOW; YOU FINISH THE ACTION WHEN THE LONG OF THE STRING ENDS. PNO.5, VIC.2

PNO. gliss. with supenbowl mallet. PNO.1

B.cl. = SPECIAL MULTIPHONIC WITH FRULL. COVERING ONLY FIRST HARMONICS. LITTLE INTERRUPTIONS FOR BREATHING ARE O.K. B.CI.1

Dg. = PEDAL NOTE WITH FRULL. THE NOTATION IS FOR VARIATIONS IN PITCH. LITTLE INTERRUPTIONS FOR BREATHING ARE O.K.

PNO. = TOUCH APPROXIMATE STRINGS WITH YOUR OPEN HAND. VERY PPP EFFECT. PNO.2

TRY TO EMULATE THE DIRECTIONS WITH THE SUPENBOWL ON THE INDICATED PARTS OF THE INSTRUMENT.

PNO. = PLAY AS FAST AS POSSIBLE FROM THE LOWEST NOTE MOVING UP AD. LIB. THE APPROXIMATE REGISTER IS WRITTEN ON THE SCORE. PNO.6

VIC. = PLAY AS FAST AS POSSIBLE MOVING ON A STRING. SOMETIMES THE BRUSH HAS TO COVER TWO STRINGS (). VIC.3

VIC. = PLAY AD. LIB. ON THE TAILPIECE. VERY PPP EFFECT. VIC.4

B.DR. = PLAY AS FAST AS POSSIBLE WITH THE BRUSH. B.DR.3

VIN. } gliss. HARMONICS AS FAST AS POSSIBLE.
VIC. } REPEAT ACTION.

PNO. = gliss. BETWEEN NOTES. DURATION OF gliss. IS AD LIB. PNO.7

Leviathan

ANGELES ROJAS

$\text{♩} = 42$

1 4 8 5 15 3 7 7 13 2 6 9 11 5

4 4 16 8 8 4 16 8 4 4 16 8 8 8

BASS CLARINET

DIDGERIDOO

BASS DRUM

PIANO

5 3 9 13 4 7 4 6 9

4 4 8 16 4 8 4 4 4

B.C.I.

Dg

B. DR.

PNO.

II

10"

20"

30"

40"

50"

60"

VIOLIN

TRIANGLE

PIANO

VLN.

TRGLE.

PNO.

S.V.
ORD.

#

II

II

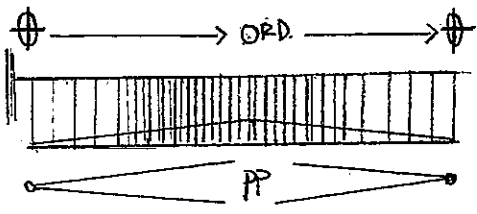

ORD.

PP

15

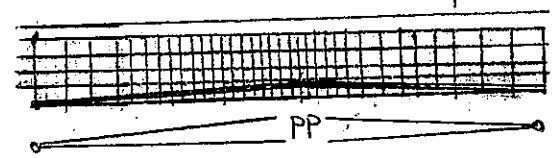
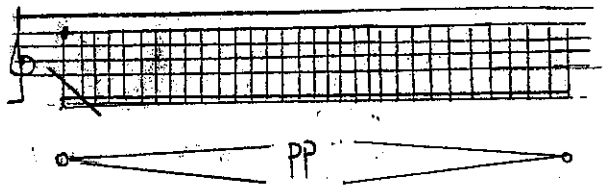

70"

80"

90"

100"

110"

120"

130"

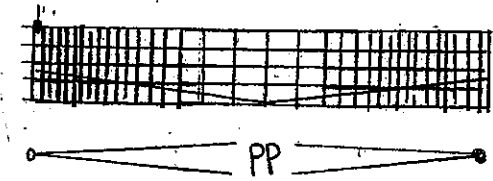
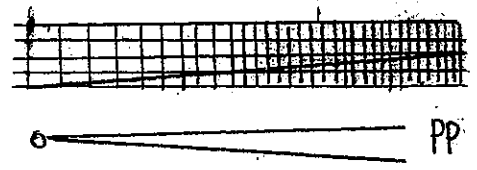
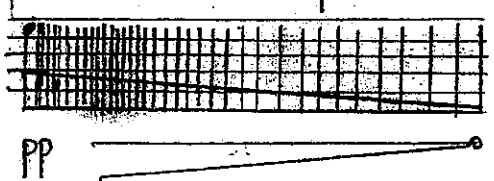
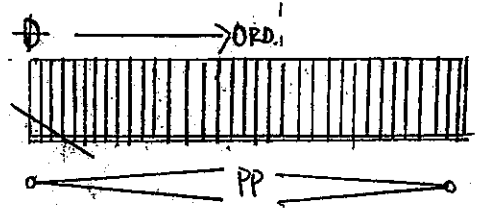
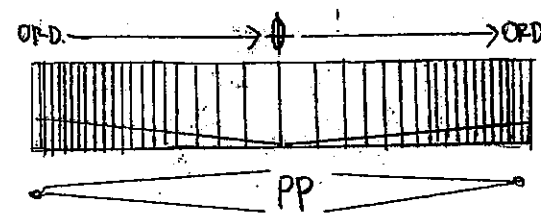
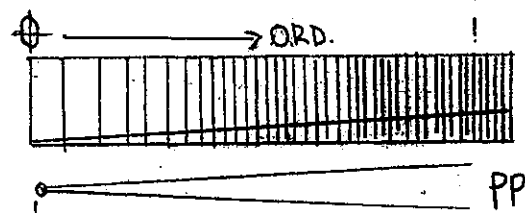
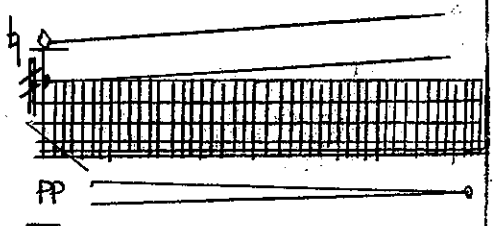
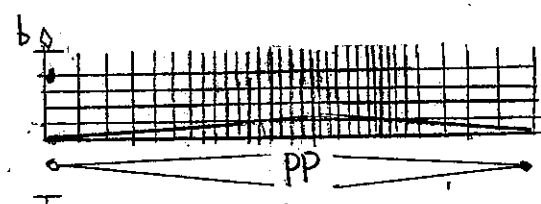
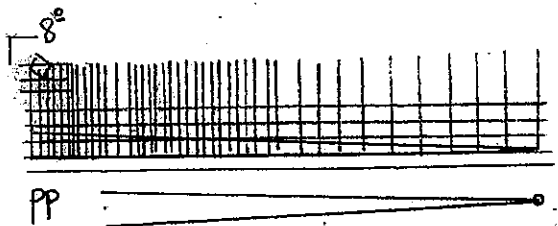



5" 10" 15" 20" 25" 30" 40"

VIOLIN ⑤

CELLO ⑤

BASS DRUM ⑤

PIANO ⑤

ANGLE OF FALL BOARD.
R.h
FALL BOARD.
L.h
PED. ALLA FINE.

45" 50" 55" 60" 65" 70" senza misura

RESONATION PATCH.

PATCH.

VIN.

VIC.

B.D.

PNO.

Musical notation for Violin (VIN.), Viola (VIC.), Bass Drum (B.D.), and Piano (PNO.). The notation includes staves with notes, rests, and dynamic markings. The Bass Drum part shows a rhythmic pattern. The Piano part shows a melodic line. The Violin and Viola parts show a melodic line with a 'senza misura' section starting at 70".

VIOLIN
CELLO
BASS DRUM
PIANO

10" 20" 30" 40" 50" 60"

IV

ARTOX-REGISTER
AD. LIB.

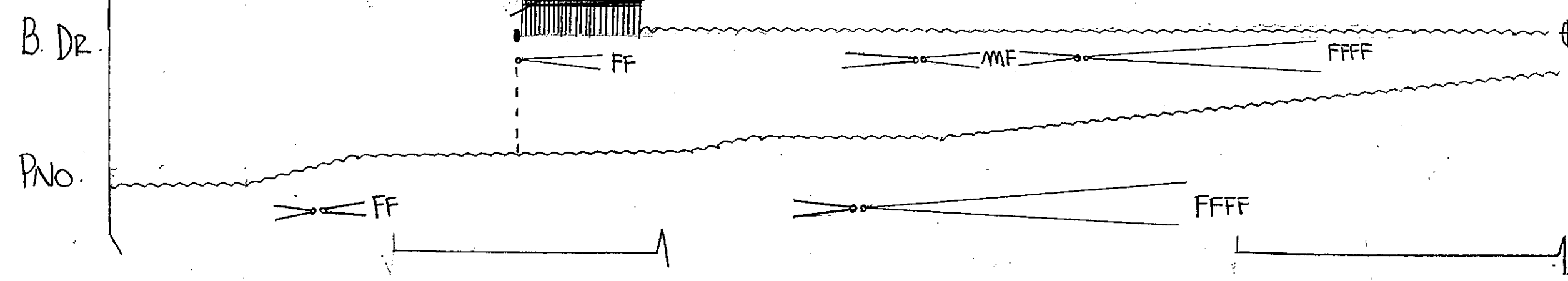
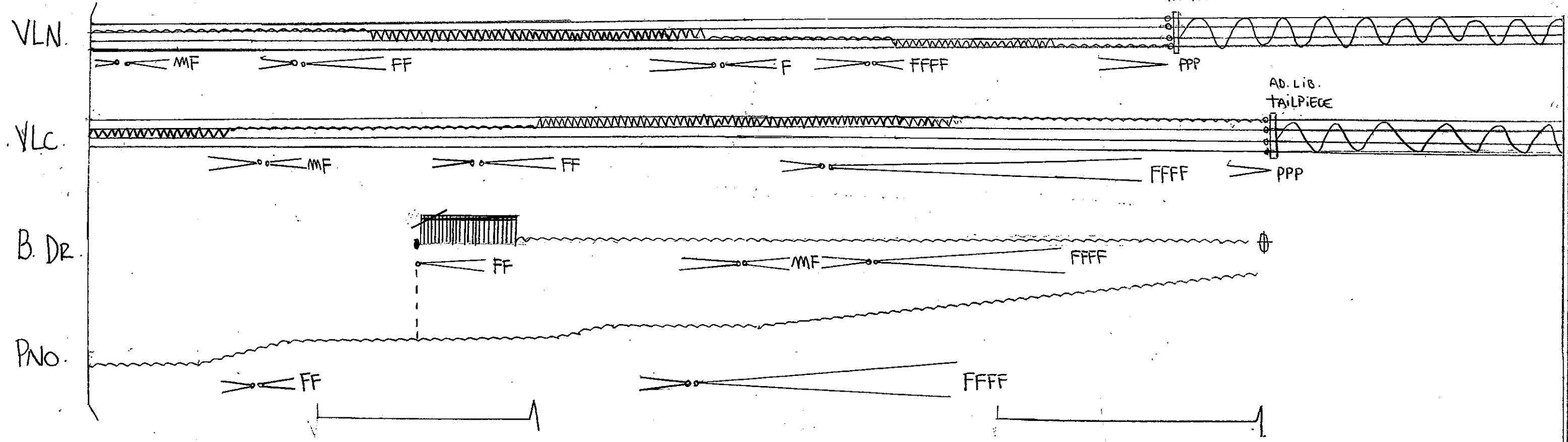
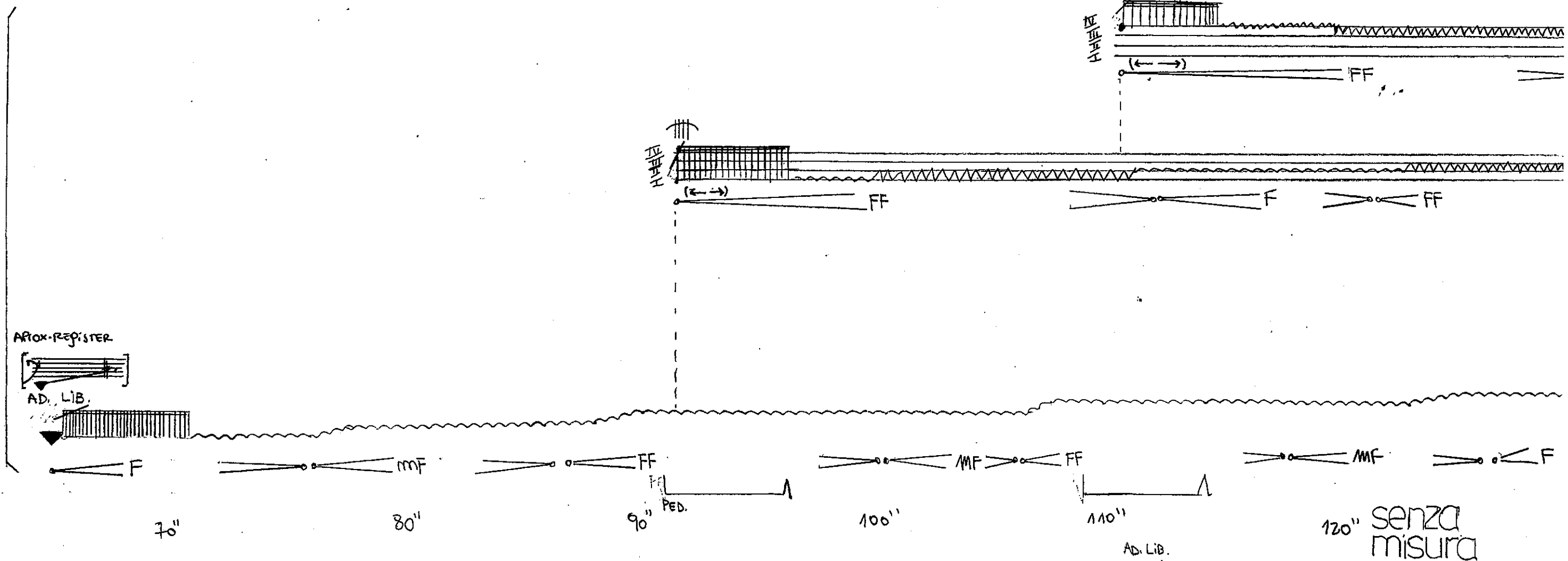

♩ = 42.

4 8 7 15 13 7 3 13 5 6 9 11 2 5
4 4 8 8 16 4 4 8 8 4 16 8 4 4

BASS CLARINET

DIDGERIDOO

Musical score for Bass Clarinet, Didgeridoo, Violin, and Cello. The score includes staves for each instrument with various musical notations such as notes, rests, and dynamic markings. Above the staves, there are performance instructions including 'SORD.', 'VIB. ORD.', 'S.V. ORD.', 'M.S.P.', and '8VA'. Dynamic markings like 'PPP', 'PP', 'MP', and 'P' are also present.

TRIANGLE

PIANO.

⑤
7 9 3 4 5 7 1 4 4 6 9
16 8 8 4 16 8 4 4 4 4 9 rit...

B. CL.

DR.

VIN.

VIC.

TRGLE.

PNO

Musical score for Bass Clarinet, Drums, Violin, Viola, Triangle, and Piano. The score includes staves for each instrument with various musical notations. Above the staves, there are performance instructions including 'VIB. M.S.P.', 'S.V. ORD.', 'VIB. ORD.', 'S.V. ORD.', '8VA', and '(simile)'. Dynamic markings like 'PPP', 'PP', 'P', and 'V' are also present.

PPP
PED.

Λ