

UC Irvine

UC Irvine Previously Published Works

Title

Fuel reduction and electricity consumption impact of different charging scenarios for plug-in hybrid electric vehicles

Permalink

<https://escholarship.org/uc/item/3pp1t0ws>

Journal

Journal of Power Sources, 196(15)

ISSN

0378-7753

Authors

Zhang, Li
Brown, Tim
Samuelsen, G Scott

Publication Date

2011-08-01

DOI

10.1016/j.jpowsour.2011.03.003

Copyright Information

This work is made available under the terms of a Creative Commons Attribution License, available at <https://creativecommons.org/licenses/by/4.0/>

Peer reviewed



Fuel reduction and electricity consumption impact of different charging scenarios for plug-in hybrid electric vehicles

Li Zhang, Tim Brown*, G. Scott Samuelson

Advanced Power and Energy Program (APEP), University of California, Irvine, Irvine, CA 92697-3550, United States

ARTICLE INFO

Article history:

Received 6 January 2011
Received in revised form 3 March 2011
Accepted 3 March 2011
Available online 10 March 2011

Keywords:

Plug-in hybrid electric vehicles
Charging scenarios
Fuel reduction
Electricity consumption

ABSTRACT

Plug-in hybrid electric vehicles (PHEVs) consume both gasoline and grid electricity. The corresponding temporal energy consumption and emission trends are valuable to investigate in order to fully understand the environmental benefits. The 24-h energy consumption and emission profile depends on different vehicle designs, driving, and charging scenarios. This study assesses the potential energy impact of PHEVs by considering different charging scenarios defined by different charging power levels, locations, and charging time. The region selected for the study is the South Coast Air Basin of California. Driving behaviors are derived from the National Household Travel Survey 2009 (NHTS 2009) and vehicle parameters are based on realistic assumptions consistent with projected vehicle deployments. Results show that the reduction in petroleum consumption is significant compared to standard gasoline vehicles and the ability to operate on electricity alone is crucial to cold start emission reduction. The benefit of higher power charging on petroleum consumption is small. Delayed and average charging are better than immediate charging for home, and non-home charging increases peak grid loads.

© 2011 Elsevier B.V. All rights reserved.

1. Introduction

1.1. Vehicle electrification

A hybrid vehicle combines two different types of propulsion systems such as an electric motor and an internal combustion engine, although other types are possible [1]. The main motivation for developing hybrid electric vehicles (HEVs) is the possibility to enhance vehicle fuel economy and to reduce greenhouse gas and pollutant emissions.

Although HEVs have been on the mass market for over 10 years, they cannot eliminate the dependence on petroleum fuel and their reduction of greenhouse gas emissions is limited. As a result, plug-in hybrid electric vehicles (PHEVs), also called off-vehicle charge capable vehicles, are being developed, which act as a HEV under charge sustaining mode [2], and consume grid electricity under charge depleting mode [2] after battery recharging. Because the grid load experiences temporal variation resulting in underutilized generation facilities, research indicates for the United States as a whole, up to 84% of U.S. cars, pickup trucks, and sport utility vehicles could be supported by the existing electric generation and transmission infrastructure. This has an estimated gasoline displacement potential of 6.5 million barrels of fuel equivalent per day, or approximately 52% of the nation's fuel imports [3]. PHEVs could

reduce greenhouse gas emissions more than standard HEVs, especially when the electricity generation mix is cleaner. Also, studies have shown that PHEVs have greater pollutant emissions benefits than conventional vehicles and hybrid electric vehicles [4,5].

Since a PHEV consumes both fuel and electricity, it is complicated to assess each of them accurately. A PHEV can be both a HEV when never charged and an EV when the battery energy is sufficient for an entire trip before the next recharging. In general, fuel and electricity consumption of a PHEV fleet depends on: (1) vehicle design parameters, such as battery capacity, electric motor size and control strategy [6]; (2) driving behaviors, such as trip length and trip time; and (3) charging behaviors, such as charging power, location and time. Several studies have analyzed PHEV adoption [7–11]. However, these assessments are derived from limited analysis, based on either macroscopic trend analysis or modeling second-by-second mechanical operations of a single vehicle [12]. These studies cannot simulate the accurate time dependent fuel and electric consumption of the vehicle fleet, nor look into the detailed impact of charging behaviors.

The goal of this study is to evaluate the temporal fuel, electricity consumption and emissions, based on different charging scenarios and vehicle parameters. A key to the study is to select a region for analysis that is both rich in data and recognized for alternative vehicle adoption. The South Coast Air Basin of California (SoCAB) is home to one of the largest vehicle fleets in the U.S. with more than 10 million vehicles [13], aggressive carbon reduction goals, and notorious air quality issues. Consequently, it is reasonable to start research in this area and expand to other areas.

* Corresponding author. Tel.: +1 949 824 0088; fax: +1 949 824 7423.
E-mail address: tmb@apep.uci.edu (T. Brown).

2. Methodology

The methodology of this study can be summarized as:

1. Observe the individual behavior of current in-use vehicles. In this study, data are derived from NHTS 2009 [14]. For each sampled vehicle, trip information is included for one day, such as time, location, and length. These data contain detailed operating information and have a relatively large sample size (7860 vehicles).
2. Build a computer simulation and replace the vehicles with PHEVs.
3. Operate each PHEV under the same behavior as observed in the NHTS, assuming people do not change driving behavior.
4. Obtain individual vehicle's temporal petroleum and electricity consumption and emission information by varying charging behaviors and vehicle parameters.
5. Sum the results.
6. Scale the results to simulate the prospective amount of vehicles or VMT.

3. Data conversion

According to the methodology above, the data used must be based on vehicle activity. However, NHTS data are based on personal activity, including any sort of transportation method, such as walking, biking, mass transit, etc. Additionally, NHTS personal data may repeat in terms of vehicle activity when there is more than one person using a single vehicle. In this case, data conversion was conducted to filter out all the vehicle activities and converted from person chain to vehicle chain. As a result, 7860 vehicles' driving and dwelling information is available for one day and are utilized in the model.

3.1. Model build

A model has been developed in Matlab. As shown in Fig. 1, the model consists of two components, operating and charging, circled by state-of-charge (SOC), which is simplified and defined as the proportion of instantaneous usable energy in the battery to the entire usable energy in the battery when full charged. One loop through the flow chart represents a specific trip and consequent dwelling activity. NHTS data, which contain the trip and dwelling information, serves as the internal input. Vehicle parameters and charging strategies are the external input, which can be changed for different scenarios. Output is the time-dependent fuel and electricity consumption and other vehicle operating information such as number and times of cold starts, and time and duration of all electric operation.

It is assumed that each PHEV begins the day with a full charge, having 100% SOC. In the operating component of the model, the vehicle consumes electricity in the battery first during charge depleting mode and then starts the engine converting to charge sustaining mode if the battery is depleted. In the charge depleting mode, the vehicle can consume both electric energy in the battery and fuel when the engine is operating to assist with meeting the extra power demand. The extent of engine operation in this mode depends on vehicle design parameters, such as battery and power limit of the traction motor and vehicle operating parameters such as velocity and acceleration. These complicated parameters are simplified by one parameter, the electrification ratio (ER), which defines the ratio of the amount of energy drawn out of the battery if driven on battery and engine, to the energy drawn out of the battery if driven on battery only. For example, a vehicle having 0.7 ER, means that for a given operating distance, on average, the

battery provides 70% of the energy and the engine provides 30%. In the California Air Resources Board's (CARB) PHEV test procedure, 'Test Procedures for 2012 and Subsequent Model Off-Vehicle Charge Capable Hybrid Electric Vehicles', a closely related ratio is called the all electric fraction [15], while other studies define similar ratios as charge decreasing electric energy fraction [16].

The final SOC from the operating component of the model is passed to the charging component in which the vehicle can be charged with a given power, location and time strategy. Based on the NHTS data, the vehicle may then embark on a second trip with a new initial SOC and go back to the operating component to circulate again until the vehicle activities terminate at the end of a day.

The parameters used in the simulation are listed below and shown in Table 1:

1. Vehicle types: conventional vehicle, hybrid electric vehicle, plug-in hybrid electric vehicle.
2. MPG: miles per gallon;
3. kWh mi⁻¹: electric energy consumption per mile in charge depleting mode from battery; The value of 0.25 kWh mi⁻¹ (0.16 kWh km⁻¹) is derived from simulating the General Motors EV 1 drivetrain with a Toyota Prius' mass and aerodynamic coefficient for two U.S. EPA drive cycles (UDDS and US06) in commercial vehicle simulation software, ADVISOR;
4. ER: electrification ratio;
5. kWh: usable battery capacity from 1 to 10 kWh;
6. Range: the corresponding all electric range from 4 to 40 mi (from 6.4 to 64 km);
7. Charging power: the limit of charging power, 1.44 kW is the typical National Electric Manufacturers Association 5-15 standard in North America;
8. Charging location: the limit of charging locations,
 - a. Home related;
 - b. Home and work related;
 - c. Anywhere;
9. Charging time: charging time strategy
 - a. Immediate charging: the vehicle is recharged immediately after a trip, at the maximum power when there are no other restrictions;
 - b. Delayed charging: if the dwelling time is longer than the necessary charging time, then the charging start time is delayed to make the ending time coincide with the start of the next trip;
 - c. Average charging: the vehicle is recharged at the minimum constant charging power required for a full SOC using the whole dwelling time when there are no other restrictions.

Delayed and average charging can be considered as two smart charging strategies that vary the charging start point, end point and charging power, but transfer the same total energy to the battery at the end of the charging period.

4. Results

The analysis determines total fuel consumption, number of cold starts, instantaneous electricity consumption, and impact on the existing grid load by varying charging strategies, charging location, time and power. All of the results below account only for the 7860 vehicles from the NHTS survey located in the SoCAB.

4.1. Fuel consumption

Fig. 2 shows the total fuel consumption per day for CV, HEV and PHEV having battery capacities ranging from

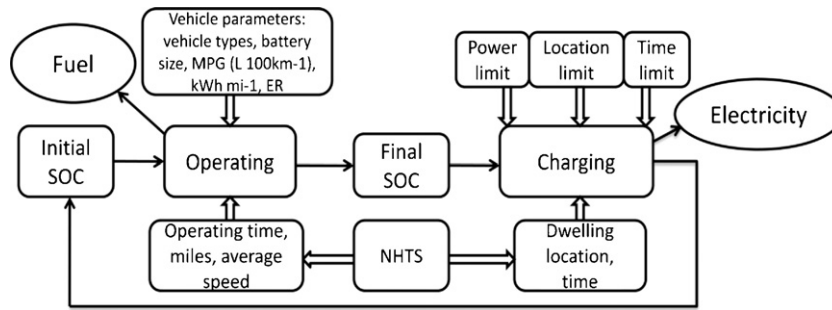

Fig. 1. PHEV operating and charging model.

Table 1
Simulation parameters.

| Vehicle type | MPG (L 100 km ⁻¹) | kWh mi ⁻¹ (kWh km ⁻¹) | ER | kWh | Range (mi) (km) | Charging power (kW) | Charging location | Charging time | Efficiency from grid to battery |
|--------------|-------------------------------|--|-------|------|-----------------|---------------------|-------------------------------|-----------------------------|---------------------------------|
| CV | 25 (9.4) | N/A | N/A | N/A | N/A | N/A | N/A | N/A | N/A |
| HEV | 45 (5.2) | N/A | N/A | N/A | N/A | N/A | N/A | N/A | N/A |
| PHEV | 45 (5.2) | 0.25 (0.16) | 0.1–1 | 1–10 | 4–40 (6.4–64) | 1.44 2.88 | Home, home and work, anywhere | Immediate, delayed, average | 0.85 |

1 kWh to 10 kWh, corresponding to all electric range of 4–40 mi (6.4–64 km).

Fuel consumption can be reduced 45% by simply switching from 25 MPG (9.4 L 100 km⁻¹) CVs to 45 MPG (5.2 L 100 km⁻¹) HEVs. Furthermore, PHEVs with 16 and 40 mi (6.4 and 64 km) all electric range can reduce fuel consumption an additional 45% and 70% respectively, compared to HEVs by only using 1.44 kW (SAE J1772 Level 1) home recharging. This result is consistent with that in the literature [17]. Fig. 2 shows that the successive reductions in fuel consumption diminish with increasing battery capacity. It is also observed that increasing charging power from 1.44 kW to 2.88 kW does not substantially reduce fuel consumption for any charging scenario; this is investigated further in a later section.

4.2. Cold start

It is important to point out vehicle cold starts due to the large proportion of pollutant emissions generated during these events.

Emission measurements of a Prius PHEV prototype indicate that cold start emissions continue to make up the majority portion of pollutant emissions [18]. Also, EMFAC [13], a vehicle operation and emission inventory model, defines cold start and operating emissions for all vehicles in the SoCAB. The greatest cold start pollutant emission reduction benefits from PHEVs can be achieved with all electric operation where ER equals 1. Research shows that blended PHEVs, such as modified PHEVs based on the Toyota Prius HEV with ER less than 1, can generate more pollutant emission than the original HEV due to numerous engine start and stops in the charge depleting mode [19].

This study assumes that cold starts occur once per trip for CV and HEV. For PHEV with all electric ability (ER equal to 1) the number of cold starts per trip is either 1 or 0, depending on whether the engine is required. Compared to fuel reduction, cold start emission reductions are even more significant for PHEVs, as shown in Fig. 3. PHEVs with 16–40 mi (6.4 and 64 km) all electric range can achieve 65% to 88% cold start emission reductions by only using Level 1 charging at home.

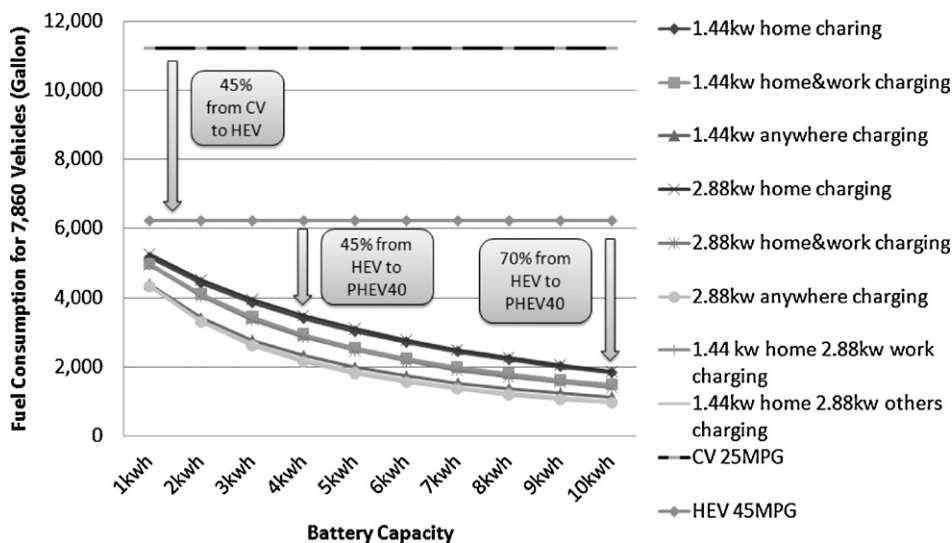

Fig. 2. Fuel savings as a function of vehicle type, PHEV battery size, and different charging scenarios.

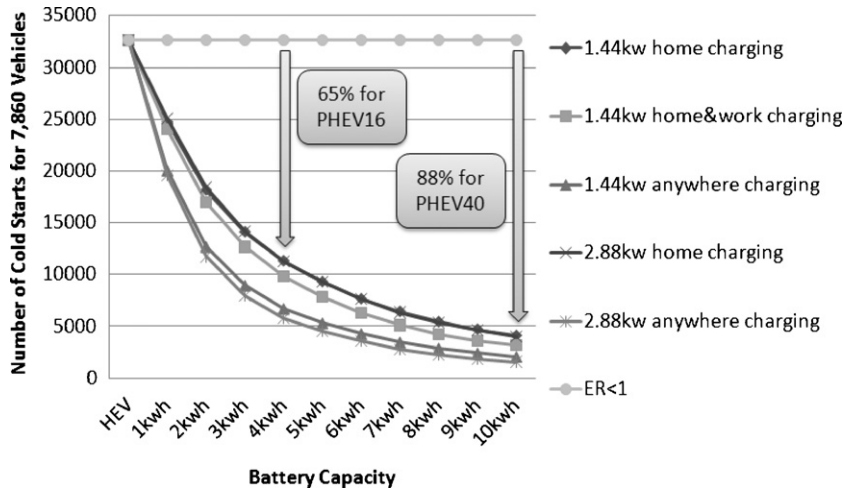

Fig. 3. Cold start emission reductions as a function of PHEV battery size and different charging scenarios.

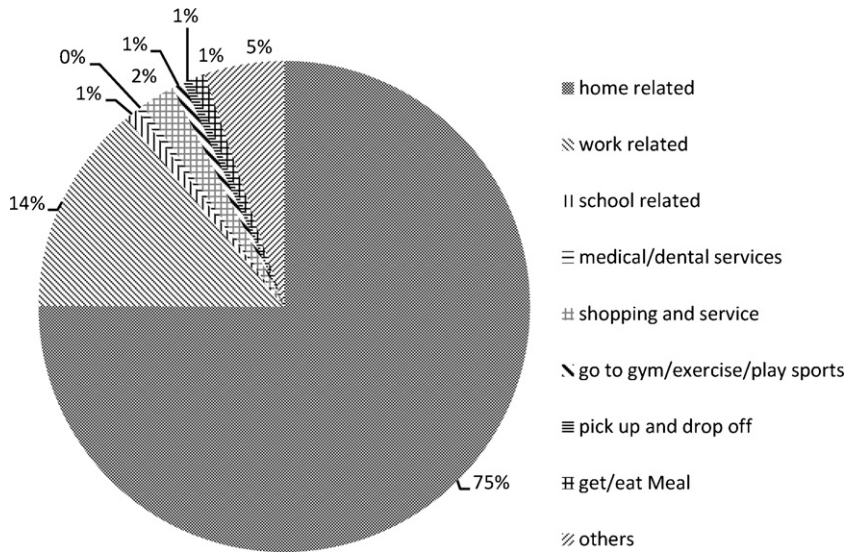

Fig. 4. Distribution of dwelling time by destination activity.

4.3. Charging location and power sensitivity

Fig. 4 shows the distribution of dwelling time for different trip destinations. Average dwelling time is shown in Fig. 5 for differ-

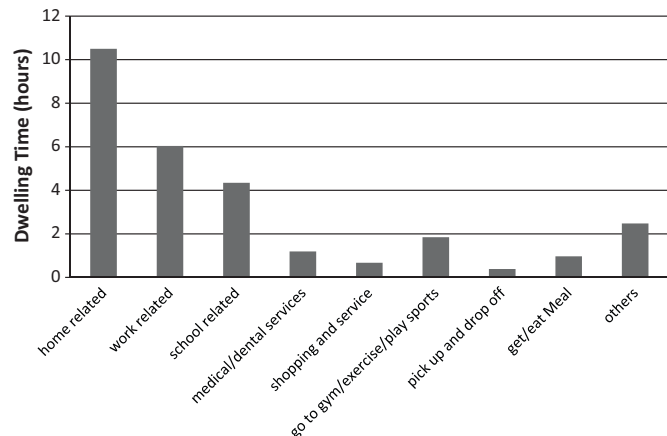

Fig. 5. Average length of dwelling time by destination activity.

ent trip destinations. Home related dwelling time makes up 75% of total dwelling time with an average of more than 10 h, while work related stops account for just 14% of total dwelling time and an average of 6 h. As for the other non-home locations, they account for only 11% of the total dwelling time, with most averaging less than 2 h. These properties of dwelling locations and corresponding average dwelling time lead to the fuel reduction sensitivity of different charging locations and power.

Fig. 6 shows the sensitivity of fuel consumption ratio to charging scenarios at different locations for Level 1 (1.44 kW) for vehicles having battery capacities from 1 kWh to 10 kWh. For each battery capacity, the fuel consumption for home charging is normalized as 1. For larger batteries, the trends from 'home charging' to 'anywhere charging' show greater benefits for larger batteries. When the battery capacity increases to 8 kWh, the fuel reduction of "home and work" and "anywhere" charging is more than 14% and 25%, respectively compared to home charging. These two numbers are the proportions of dwelling time of work related and non-home locations on the whole dwelling time, shown in Fig. 4. This result demonstrates that larger batteries can enhance the benefit of charging at non-home locations. However, the extra fuel reduction relies on infrastructure improvement at these locations. In a recent sur-

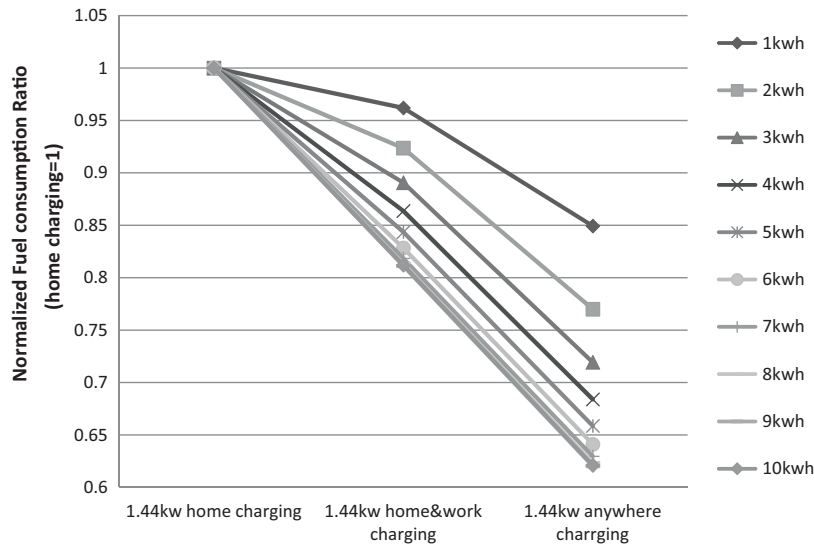

Fig. 6. Charging location sensitivity on fuel consumption for different PHEV battery capacity.

vey conducted to evaluate PHEV infrastructure readiness, results show that few respondents found non-home recharge locations: 4.8% found outlets at work, 2.3% at a store or restaurant, and 9.7% at other locations [20].

In Fig. 2 it is difficult to distinguish the fuel reduction impact from 1.44 kW to 2.88 kW charging. Similarly, Fig. 7 shows charging power sensitivity, in which fuel consumption for 1.44 kW charging is normalized as 1. For both 4 kWh and 8 kWh battery capacity PHEVs (PHEV16 and PHEV32), increasing home charging power from 1.44 kW up to 7.2 kW can reduce fuel consumption by less than 5%, because home related dwelling time is longer than 10 h, on average. When it comes to both home and work related charging, the benefit of faster charging is still less than 10% due to the relatively long average dwelling time, more than 6 h at work related locations.

For locations other than home and work due to the shorter dwelling time (about 4 h at school and about 2 h or less elsewhere) increasing charging power, up to 7.2 kW, decreases fuel consumption by 20% when compared to 1.44 kW charging. However, this benefit relies on higher power circuit upgrades at non-home locations.

Based on the results presented in Figs. 2, 6 and 7, it is shown that increasing battery capacity and utilizing only home charging may offer a greater benefit for fuel reduction compared to upgrading non-home charging infrastructure. However, accurate battery and infrastructure cost is necessary to provide a more comprehensive comparison.

4.4. Instantaneous electricity consumption

An important consideration of PHEVs is the instantaneous electricity consumption of the fleet and the corresponding impact on existing grid load. PHEV infrastructure readiness survey data revealed that 52.4% respondents identified electrical outlets at their home within 25 ft (7.6 m) of where a vehicle is parked [20]. NEMA 5-15 rated at 1.44 kW is the standard electrical outlet in the U.S. Consequently, 1.44 kW immediate home charging is the most likely near-term scenario due to the availability of 1.44 kW electric outlets and a simple charging strategy. Fig. 8 shows the instantaneous electricity consumption profile for different battery capacities, from PHEV4 to PHEV40. The curve peak is shifted from 6:00 p.m. to 9:00 p.m. with increased battery capacity. Fig. 9

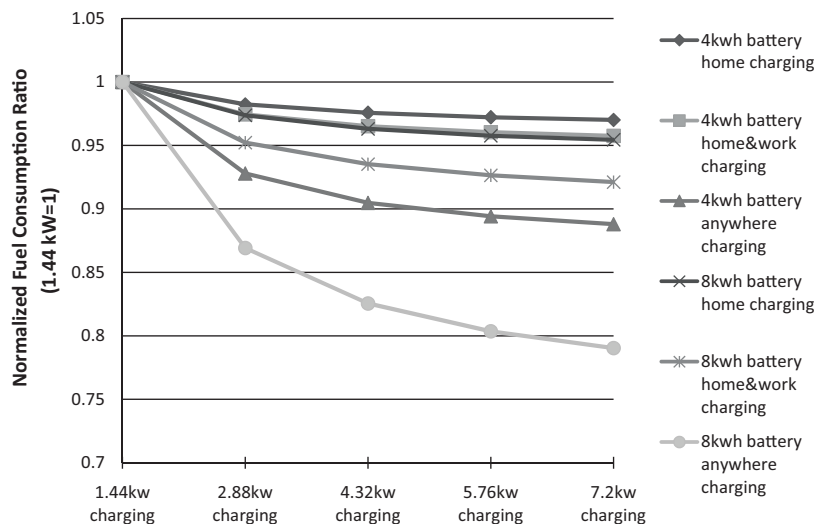

Fig. 7. Charging power sensitivity on fuel consumption for different charging locations.

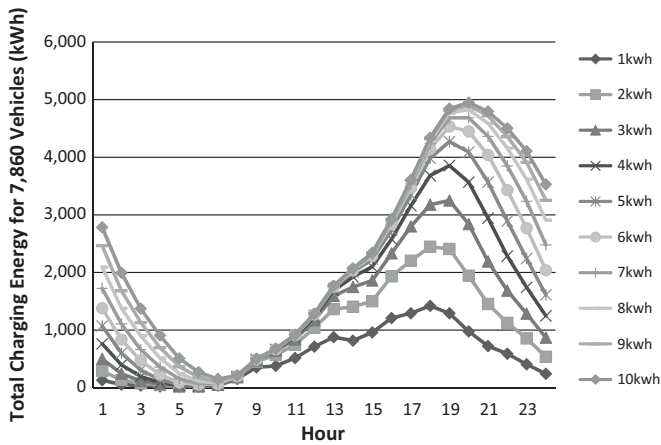

Fig. 8. Battery capacity effects on PHEV fleet charging load based on home 1.44 kW immediate charging.

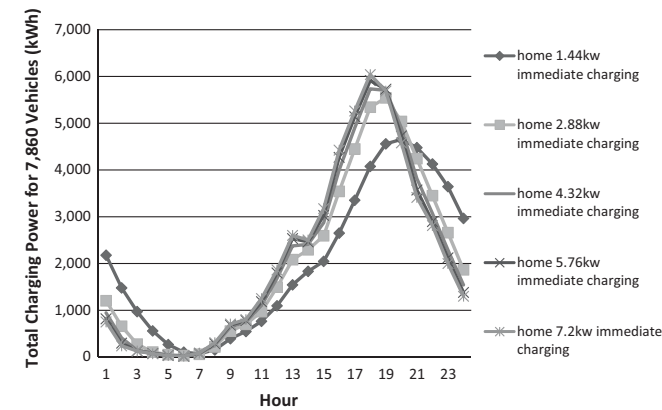

Fig. 9. Charging power effects on PHEV fleet charging load based on PHEV32.

shows the instantaneous electricity consumption profile for different charging power assuming a PHEV32 and immediate home charging. Increasing charging power raises the peak charging load and shifts it to an earlier time of day. Similar trends hold for PHEV4 through PHEV40.

Compared to the existing SoCAB grid load during an extreme summer day as shown in Fig. 10, higher charging power for immediate home charging pushes the PHEV fleet load peak earlier in the day, closer to the system wide load peak. Immediate home charging at power greater than 1.44 kW does not significantly impact fuel reduction as discussed previously; however, higher power home

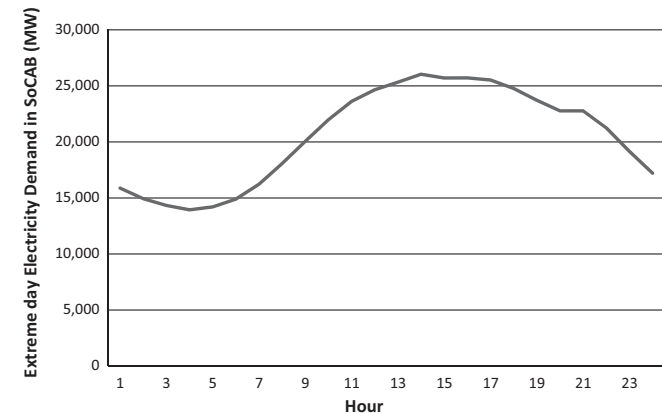

Fig. 10. Temporal SoCAB electricity power demand for extreme summer day.

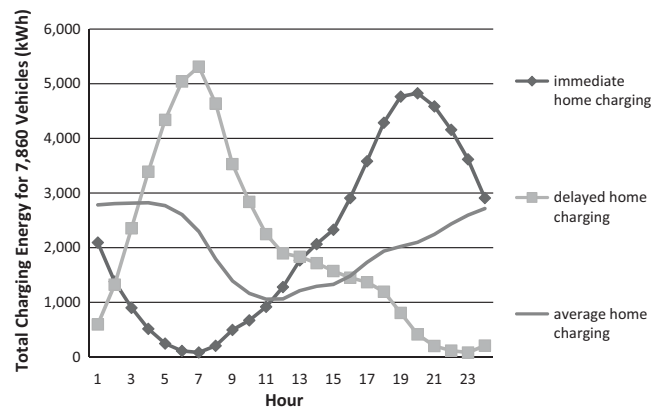

Fig. 11. Three charging profiles for Level 1 (1.44 kW) home charging based on PHEV32.

charging will have the undesired effect of increasing the peak load on the electric grid. In contrast, larger PHEV battery capacity utilizing 1.44 kW immediate home charging will push the PHEV charging peak away from coincidence with the normal grid peak (Fig. 8). For reference, there are nearly 10 million light duty automobiles in the SoCAB region. If just 10% were PHEV32s following the 5.76 kW immediate home charging scenario depicted in Fig. 9, then 752 MW of additional generation would be needed from 5:00 to 6:00 p.m., resulting in a new maximum summertime peak load.

4.5. Other charging strategies

Home charging and immediate charging are the basic levels for charging location and charging start time, respectively. Workplace and anywhere charging locations, and delayed and average charging times are investigated, as well as their impacts on current grid load.

As shown in Fig. 11, total charging energy with 1.44 kW home charging is plotted for immediate, delayed, and average charging profiles. Delayed charging has a similar profile shape to that of immediate charging, but the peak is delayed to between 5:00 a.m. and 9:00 a.m. in the morning. The slightly higher and sharper peak of the delayed charging profile is due to the more consistent start time of morning trips compared to returning home trips in the evening. In this case, the PHEV charging electricity peak coincides nicely with the nighttime dip in the SoCAB load curve to fill the concave valley on existing grid load. However, the impacts to the distribution grid and local transformers must be further investigated. Additionally, a strategy that postpones charging until the early morning would undoubtedly require strong incentives for consumer adoption.

Another feasible charging strategy is average charging, where it is not necessary to charge the vehicle with the maximum power limit but instead, the minimum charging power is set depending on the dwelling time. For the average charging scenario, there is no peak hour, but a relatively flattened curve which decreases the maximum magnitude of the other charging strategies by roughly half. As shown in Fig. 11, it can also make full use of the grid valley in the late night and early morning period, while slightly increasing the peak load in the afternoon. Both delayed and average charging strategies are very basic, only relying on the dwelling time information. It is believed that with more smart charging strategies and feedback from the grid, the impact to the existing grid load of electricity consumption of PHEV fleet can be better optimized [21].

When the charging location is changed to home and work related and anywhere, the instantaneous electricity consumption of immediate, delayed and average charging scenarios, as shown

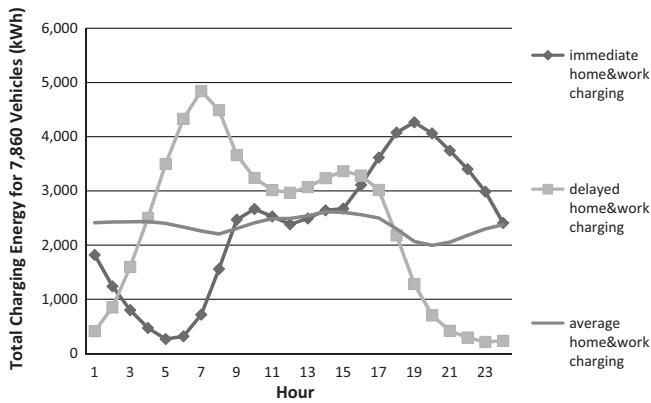

Fig. 12. Three charging profiles for Level 1 (1.44 kW) home and work related charging based on PHEV 32.

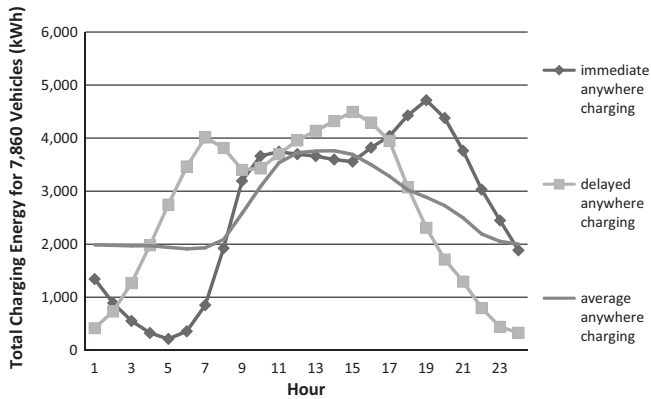

Fig. 13. Three charging profiles for Level 1 (1.44 kW) anywhere charging based on PHEV 32.

in Figs. 12 and 13, change in a similar way. Between 9:00 a.m. and 5:00 p.m., electricity consumption of all three charging strategies increases when the charging location is changed from home to everywhere. During the other periods of the day, the trend changes little with only a slight decrease in magnitude. Unlike home based charging scenarios, at non-home locations, neither the delayed nor average charging strategy can change the instantaneous electricity consumption in the time period of 9:00 a.m. to 5:00 p.m.; all have similar characteristics in terms of trend and magnitude.

The phenomena can be attributed to the property of people’s activity. Derived from the travel survey data, Fig. 14 shows the distribution of dwelling vehicles in terms of different trip destinations. Daytime, particularly from 9:00 a.m. to 5:00 p.m., is when most

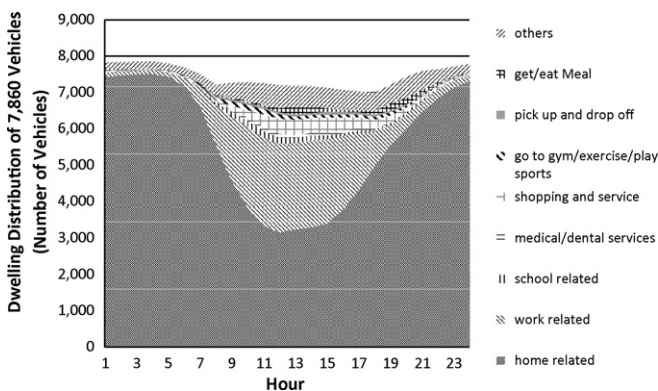

Fig. 14. 24-h distribution of dwelling vehicles for different destinations.

of the non-home dwelling activities happen, while home dwelling occurs at different times. Therefore, the electricity consumption increases in this period when work related and other locations are added for charging. On the other hand, as shown in Fig. 5, the average dwelling time at other locations is relatively shorter than home; 6 h for work related locations and less than 2 h for other locations, so immediate, delayed and average charging have little impact for work related and other locations. Other more intelligent charging strategies should be evaluated. However, due to the properties of dwelling time, it is not promising that the electricity consumption would change significantly in this time period when non-home charging locations are added.

5. Conclusions

The energy impact of plug-in hybrid electric vehicles in SoCAB has been evaluated based on NHTS 2009, by analyzing the all electric range and different charging scenarios in a vehicle operation and charging model. The following conclusions are drawn:

The study adopts the SoCAB as an example, but the methodology, the model, and the NHTS data can be used for other areas.

PHEV16 and PHEV40 can reduce fuel consumption by 45% and 70% respectively, compared to the corresponding HEV by only charging at home with Level 1 charging at a maximum of 1.44 kW. The cold start criteria pollutant emission reductions are 65% and 88%, respectively.

Increasing charging locations to anywhere at 1.44 kW can save more fuel (up to 35% for PHEV32) compared to only home charging at 1.44 kW. Increasing charging power to 7.2 kW at home, home and work related locations, and anywhere can reduce fuel consumption by less than 5%, 10% and 20% for PHEV 32 compared to 1.44 kW charging at these three locations. Considering the massive installation of infrastructure that would be required for high power, non-home charging locations, large batteries with home 1.44 kW charging show the potential for considerable fuel reduction with minimal infrastructure investment.

Immediate home charging results in an electricity demand peak from 6:00 p.m. to 9:00 p.m., averaging less than 1 kW per vehicle. Increasing immediate home charging power from 1.44 kW to 7.2 kW would undesirably shift the peak hour closer to the existing grid peak.

By knowing the starting time of the next trip, delayed and average charging strategies can be implemented having the same fuel reduction as immediate charging, but different instantaneous electricity consumption impacts. For home related locations, delayed charging can move the PHEV charging peak hour to the morning to avoid the existing grid peak time, smooth the PHEV consumption curve, and decrease the PHEV demand peak load by 50%.

Charging at non-home locations adds to the existing peak grid load during daytime, between 9:00 a.m. and 5:00 p.m. Immediate, delayed, and average charging show similar results in this period. It is not likely to eliminate this drawback by using more intelligent charging strategies due to the property of people’s driving and dwelling activity.

Acknowledgements

This work is associated with the California Clean Mobility Partnership, a collaborative program between the Berkeley and Irvine campuses of the University of California, supported by the California Air Resources Board under the Alternative Fuel Incentive Program (AFIP) enacted as part of California State Assembly Bill 1811 and by Toyota Motor Engineering & Manufacturing North America, Inc. The authors greatly appreciate assistance and resources provided by Toyota.

References

- [1] M. John, German, Hybrid Powered Vehicle, 2003, ISBN: 978-0-7680-1310-8.
- [2] SAE, Recommended Practice for Measuring the Exhaust Emissions and Fuel Economy of Hybrid-Electric Vehicles, Including Plug-in Hybrid Vehicles, SAE Standard J1711, 2010.
- [3] Michael Kintner-Meyer, Kevin Schneider, Robert Pratt, Impacts Assessment of Plug-in Hybrid Vehicles on Electric Utilities and Regional U.S. Power Grids, Pacific Northwest National Laboratory, 2006.
- [4] R. Graham, Comparing the Benefits and Impacts of Hybrid Electric Vehicle Options, EPRI, Palo Alto, CA, 2001.
- [5] K. Parks, P. Denholm, T. Markel, Costs and Emissions Associated with Plug-In Hybrid Electric Vehicle Charging in the Xcel Energy Colorado Service Territory, NREL, NREL/TP-640-41410, 2007.
- [6] Jeffrey Gonder, Tony Markel, Energy Management Strategies for Plug-In Hybrid Electric Vehicles, SAE Paper, 2007-01-0290, 2007.
- [7] H. Bradley Thomas, W. Quinn Casey, Analysis of plug-in hybrid electric vehicle utility factors, Journal of Power Sources 195 (2010) (2010) 5399–5408.
- [8] Stephanie Stockar, Pinak Tulpule, Vincenzo Marano, Giorgio Rizzi, Energy, Economical and Environmental Analysis of Plug-In Hybrids Electric Vehicles Based on Common Driving Cycles, SAE Paper, 2009-24-0062, 2009.
- [9] Richard “Barney” Carlson, Michael Duoba, Neeraj Shidore, Drive Cycle Fuel Consumption Variability of Plug-In Hybrid Electric Vehicles Due to Aggressive Driving, SAE Paper, 2009-01-1335, 2009.
- [10] Constantine Samaras, Kyle Meisterling, Environmental Science and Technology 42 (9) (2008) 3170–3176.
- [11] Saeid Bashash, Scott J. Moura, Joel C. Forman, Hosam K. Fathy, Journal of Power Sources 196 (2011) (2011) 541–549.
- [12] Jee E. Kang, W.W. Recker, Transportation Research Part D 14 (2009) (2009) 541–556.
- [13] California Environmental Protection Agency Air Resources Board, EMFAC, available at: http://www.arb.ca.gov/msei/onroad/latest_version.htm.
- [14] U.S. Department of Transportation Federal Highway Administration, 2009 National Household Travel Survey, available at: <http://nhts.ornl.gov/download.shtml#2009>.
- [15] California Environmental Protection Agency Air Resources Board, California Exhaust Emission Standards and Test Procedures for 2009 and Subsequent Model Zero-Emission Vehicles and Hybrid Electric Vehicles, in the Passenger Car, Light-Duty Truck and Medium-Duty Vehicle Classes, available at: http://www.arb.ca.gov/msprog/levprog/test_proc.htm.
- [16] E.D. Tate, Peter J. Savagian, The CO₂ Benefits of Electrification E-REVs, PHEVs and Charging Scenarios, SAE Paper, 2009-01-1311, 2009.
- [17] T. Markel, K. Smith, A. Pesaran, Presented at EVS-24 International Battery, Hybrid and Fuel Cell Electric Vehicle Symposium Stavanger, Norway, May 13–16, 2009, 2009.
- [18] D. Allgood, T. Brown, S. Samuelsen, International Journal of Engine Research 11 (2010).
- [19] Richard W. Carlson, Michael J. Duoba, Theodore P. Bohn, Anantray D. Vyas, Testing and Analysis of Three Plug-in Hybrid Electric Vehicles, SAE Paper, 2007-01-0283, 2007.
- [20] Jonn Axsen, Ken Kurani, The Early U.S. Market for PHEVs: Anticipating Consumer Awareness, Recharge Potential, Design Priorities and Energy Impacts, UCD-ITS-RR-08-22, 2008.
- [21] H. Jansen Karel, M. Brown Tim, G. Scott Samuelsen, Journal of Power Sources 195 (16) (2010) 5409–5416.