

UC Irvine

UC Irvine Previously Published Works

Title

Hybrid Gas Turbine Fuel Cell Systems

Permalink

<https://escholarship.org/uc/item/3k47s2tq>

Author

Brouwer, J

Publication Date

2003

Copyright Information

This work is made available under the terms of a Creative Commons Attribution License, available at <https://creativecommons.org/licenses/by/4.0/>

Peer reviewed

1.4

Hybrid Gas Turbine Fuel Cell Systems



Professor Jack Brouwer, Ph.D.

Associate Director
National Fuel Cell Research Center
University of California
Irvine, CA 92697-3550

email: jb@nfcrc.uci.edu
<http://www.nfcrc.uci.edu>

1.4-1 Introduction

With increasing energy demands, dwindling fossil energy resources, and environmental concerns associated with criteria pollutants and greenhouse gases, significant attention in the gas turbine community has been focused on increasing efficiency and reducing emissions. A highly efficient and low emitting concept that has been considered for the future is the hybrid gas turbine high temperature fuel cell concept.

Hybrid fuel cell technologies may enable the U.S. to meet its future energy demands while enhancing energy efficiency, reliability and security, and reducing environmental impact. Hybrid systems are comprised of integrated gas turbines and fuel cells with other technologies. A myriad of potential configurations exists with hundreds of cycles proposed and investigated. In each case these hybrid cycles exhibit a synergistic energy and environmental performance enhancement through novel individual technology components, unique systems integration, advanced energy conversion devices, innovative pollutant mitigation approaches, and/or increased fuel flexibility and applicability.

These types of hybrid systems have been developed and proposed for operation on natural gas, coal, biomass and other fossil fuels. Both experimental and theoretical analyses of such hybrid gas turbine fuel cell systems have indicated that such hybrid systems can achieve very high fuel-to-end-use efficiency and very low emissions. The environmental and energy efficient performance of these hybrid systems could allow them to make major contributions to new and secure fossil-fueled energy infrastructure and could assist in the provision of fuels, value added products, and introduction of the hydrogen economy.

Integrated hybrid cycles exhibit synergies not present in typical combined cycles with fuel-to-electricity efficiencies higher than either the fuel cell or gas turbine alone and costs for a given efficiency that may become lower than either alone. Significant improvement of high temperature fuel cell technology robustness and cost is required for the development of hybrid gas turbine fuel cell systems. The advancement of high temperature fuel cell technology in the last decade has been significant and expectations are that it will become commercially viable in coming decades. Once high temperature fuel cells become commercially viable, stand-alone fuel cell systems may compete with gas turbine technology in the electricity production sector. However, this will not occur without a natural evolution toward significant use of hybrid systems that use both gas turbine and fuel cell technology. This natural evolution will be driven by the superior efficiency and emissions performance of hybrid systems.

Economies, industry, citizens and the environment could all benefit from the advancement and deployment of gas turbine fuel cell hybrid systems due to high energy efficiency, and reduced environmental impact. No fossil-fuel based technology can compete with the high efficiency and environmental performance of gas turbine fuel cell hybrid systems. In addition, the market applications for hybrid gas turbine fuel cell technologies are myriad. They include the future potential application to large central station power plants operated on a variety of fuel resources, distributed generation support of traditionally energy intensive industries, local commercial applications and various distributed generation scenarios. In addition, hybrid fuel cell technologies can be used to support the auxiliary power and propulsion power needs of aircraft, spacecraft, satellites, ships, and trains.

Although the potential for gas turbine fuel cell hybrid systems is significant, the front-end risk associated with developing this technology is considerable. Broad investment in industry, at national laboratories, and in university research and development is required to advance hybrid gas turbine fuel cell technology.

1.4-2 Background

Hybrid gas turbine fuel cell systems are comprised of two major components, a high temperature fuel cell and a gas turbine engine. Since this handbook provides sufficient background information on gas turbine technology, background information on fuel cell technology for use in integrated hybrid cycles is the focus of this section. Brief background information regarding gas turbine technology for hybrid applications is included.

1.4-3 Fuel Cell Technology

Fuel Cell History and Background

In the late 1830s, Sir William Grove and Professor Christian Friedrich Schoenbein discovered fuel cells. The discovery was accomplished by postulating and proving that the process of water hydrolysis could be reversed through the provision of hydrogen and oxygen to the electrode surfaces of an electrolytic cell to produce water and electricity. Unfortunately, the fuel cells of Sir Grove and his contemporaries did not garner serious interest in an era where high-powered steam engines were proving to produce power levels of interest. In the early 1960s, however, fuel cells began to be developed as a power generating technology for space applications that required strict environmental and efficiency performance. The successful demonstration of efficient and environmentally sensitive fuel cells in space led to their serious consideration for terrestrial applications in the 1970s.

From 1970 through the 1980s, fuel cell research and development was confined to a small number of companies and research institutions. Due to the emergence of several new fuel cell types (e.g. solid oxide and molten carbonate fuel cells), the last decades have produced a tremendous expansion and diversification of developers and manufacturers, which has expanded the list of potential products and applications of fuel cells. Almost all research and development efforts have pointed to and successfully demonstrated the environmentally sensitive features of fuel cell technology, principally regarding ultra-low to zero criteria pollutant emissions. In addition, many efforts have proven that fuel cells can produce electricity with fuel-to-electricity conversion efficiencies that are higher than similarly sized traditional electricity production technology (e.g., gas turbine).

The advancement of fuel cell technology has been accomplished with significant investments from the U.S. Department of Energy, European Union, Japanese New Energy Technology Development Organization (NEDO) and similar agencies around the world together with hundreds of companies. Significantly, the largest annual investments in fuel cell technology today are coming from the private sector and major industries (e.g., automobile, power generation). These investments are often focused on overcoming the principal barrier to widespread use of fuel cells in today's market, fuel cell capital cost.

There are many specific technical challenges and technical hurdles that contribute to the high capital cost of fuel cell technology that the fuel cell community is currently addressing to make fuel cells commercially viable. While the details of these technical challenges are not discussed herein, note that until and unless fuel cell technology itself becomes commercially viable the potential for hybrid gas turbine fuel cell systems will be limited. Note additionally, however, that government agencies, national laboratories, researchers and industry agree that successful commercialization and market viability of fuel cells is likely to occur within the decade.

General Fuel Cell Characteristics

Fuel cells are electrochemical devices that convert the chemical energy of a fuel directly to usable energy - electricity and heat - without combustion. This is quite different from most electric generating devices (e.g., steam turbines, gas turbines, reciprocating engines), which first convert the chemical energy of a fuel to thermal energy, then to mechanical energy and finally to electricity.

Fuel cells are similar to batteries containing electrodes and electrolytic materials to accomplish the electrochemical production of electricity. Batteries store chemical energy in an electrolyte and convert it to electricity on demand, until the chemical energy has been depleted. Applying an external power source can recharge depleted secondary batteries, but primary batteries must be replaced. Fuel cells do not store chemical energy, but rather, convert the chemical energy of a fuel to electricity. Thus fuel cells do not need recharging and can continuously produce electricity as long as fuel and oxidant are supplied.

Figure 1 presents the basic components of a fuel cell, which include a positive electrode (anode), negative electrode (cathode) and an electrolyte. Fuel is supplied to the anode (positive electrode) while oxidant is supplied to the cathode (negative electrode). Fuel is electrochemically oxidized on the anode surface and oxidant is electrochemically reduced on the cathode surface. Ions created by the electrochemical reactions flow between anode and cathode through the electrolyte. Electrons produced at the anode flow through an external load to the cathode completing an electric circuit.

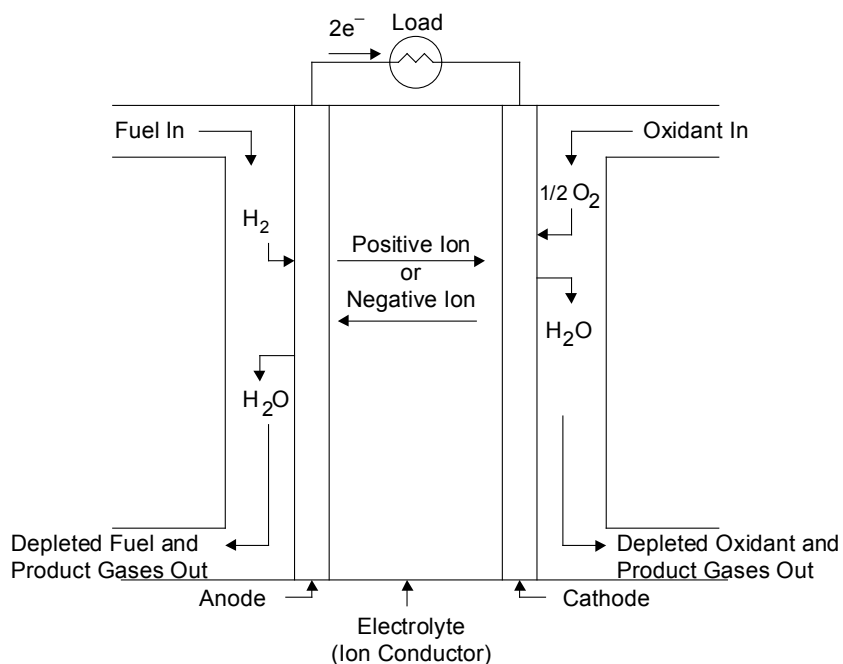

Fig. 1. General schematic of a fuel cell

A typical fuel cell requires gaseous fuel and oxidant flows. Hydrogen is the preferred fuel because of its high reactivity, which minimizes the need for expensive catalysts, and because electro-oxidation of hydrogen leads only to water emission. Hydrocarbon fuels can be supplied but typically require conversion to hydrogen or a hydrogen-rich mixture before electrochemical reaction can occur. This fuel processing step can be accomplished prior to entering the fuel cell (for lower temperature fuel cells) or within the fuel cell (for higher temperature fuel cells). Oxygen in air is the preferred oxidant because of its availability in the atmosphere.

As indicated in Figure 1, the electrolyte serves as an ion conductor. The direction of ion transport depends upon the fuel cell type, which determines the type of ion that is produced and transported across the electrolyte between the electrodes. The various fuel cell types are described in a subsequent section.

A single fuel cell is only capable of producing about 1 volt, so typical fuel cell designs link together many individual cells to form a “stack” that produces a more useful voltage. A fuel cell stack can be configured with many groups of cells in series and parallel connections to further tailor the voltage, current and power produced. The number of individual cells contained within one stack is typically greater than 50 and varies significantly with stack design.

Figure 2 presents the basic components that comprise the fuel cell stack. These components include the electrodes and electrolyte of Figure 1 with additional components required for electrical connections and to provide for the flow of fuel and oxidant to each cell in the stack. These key components include current collectors, separators, and gas flow channels, which are often integrated into one design as in the “interconnect” design pictured in Figure 2. This interconnect serves as current collector and gas separator and provides the flow channels for both fuel and oxidant. The interconnect provides the electrical connections between cells and physically separates the oxidant flow of one cell from the fuel flow of the adjacent cell. The channels serve as the distribution pathways for the fuel and oxidant.

The preferred fuel for most fuel cell types is hydrogen. Hydrogen is not readily available, but, and the infrastructure for provision of hydrocarbon fuels is well established in our society. Thus, fuel cell systems that have been developed for practical power generation applications to-date have been designed to operate on hydrocarbon fuels. This typically requires the use of a fuel processing system or “reformer” as shown in Figure 3. The fuel processor typically accomplishes the conversion of hydrocarbon fuels to a mixture of hydrogen rich gases and, depending upon the requirements of the fuel cell, subsequent removal of contaminants or other species to provide pure hydrogen to the fuel cell.

In addition to the fuel cell system requirement of a fuel processor for operation on hydrocarbon fuels, Figure 3 presents the need for a power conditioning or inverter system component as well. This is required for the use of current end-use technologies that are designed for consuming alternating current (AC) electricity, and for grid connectivity in distributed power applications. Since the fuel cell produces direct current (DC) electricity, the power conditioning section is a requirement for fuel cell systems that are designed for distributed generation today. In the future, systems and technologies may be amenable to the use of DC electricity, which would allow significant cost savings.

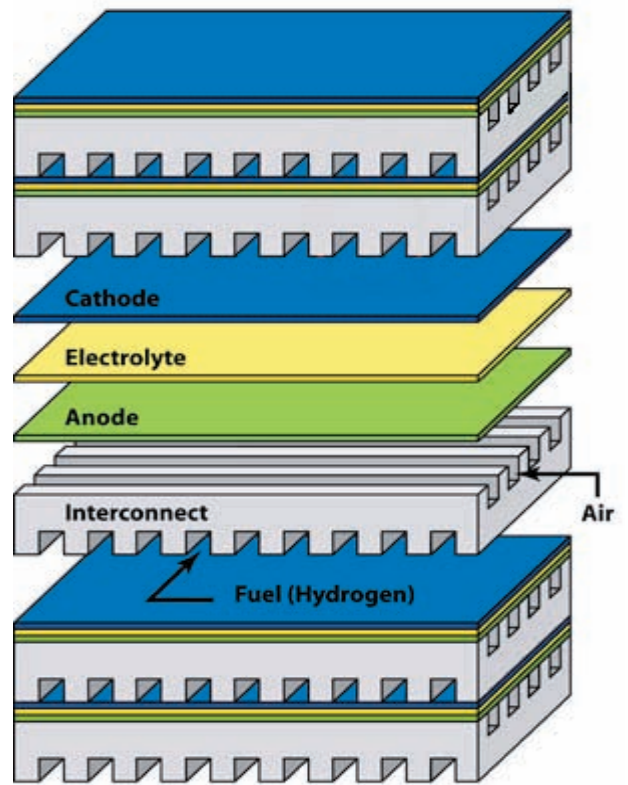

Fig. 2. Basic components of a fuel cell stack

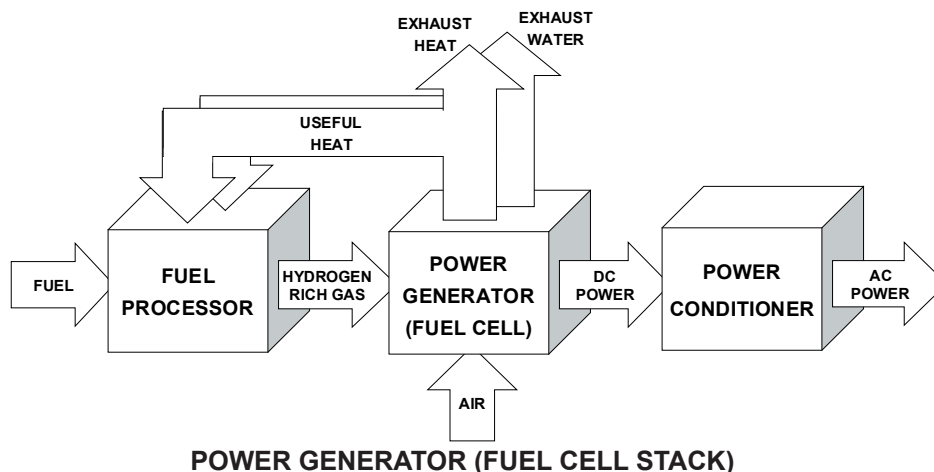

Fig. 3. Basic schematic of the major components in a fuel cell system

1.4 Hybrid Gas Turbine Fuel Cell Systems

Fuel Cell Types

There are five principle types of fuel cells that are currently in various stages of commercial availability, or undergoing research, development and demonstration. These five fuel cell types are significantly different from each other in many respects; however, the key distinguishing feature is the electrolyte material. The type of electrolyte material is generally used to describe each fuel cell type. Thus the five types of fuel cells are (in alphabetical order): (1) Alkaline Fuel Cell (AFC), (2) Molten Carbonate Fuel Cell (MCFC), (3) Phosphoric Acid Fuel Cell (PAFC), (4) Proton Exchange Membrane Fuel Cell (PEMFC), and (5) Solid Oxide Fuel Cell (SOFC).

Alkaline fuel cells were the first type of fuel cell to be widely used for space applications. AFCs contain a potassium hydroxide (KOH) solution as the electrolyte. AFCs operate at temperatures between 100°C and 250°C (211°F and 482°F).

Molten carbonate fuel cells are now being tested in full-scale demonstration plants from 250 kW to 1.5 MW output. The electrolyte in an MCFC is an alkali carbonate (sodium, potassium, or lithium salts, Na_2CO_3 , K_2CO_2 , or Li_2CO_3) or a combination of alkali carbonates that is retained in a ceramic matrix of lithium aluminum oxide (LiAlO_2). An MCFC operates at 600 to 700°C where the alkali carbonates form a highly conductive molten salt with carbonate ions (CO_3^-) providing ionic conduction through the electrolyte matrix.

Phosphoric acid fuel cells have been commercialized for stationary power applications and remain the most mature fuel cell technology. PAFCs use a concentrated 100% phosphoric acid (H_3PO_4) electrolyte retained on a silicon carbide matrix and operate at temperatures between 150 and 220°C.

The proton exchange membrane fuel cell is also known as the solid polymer or polymer electrolyte fuel cell. A PEMFC contains an electrolyte that is a layer of solid polymer (usually a sulfonic acid polymer, whose commercial name is Nafion™) that allows protons to be transmitted from one face to the other.¹ PEMFCs require relatively pure hydrogen that typically must be humidified. PEMFCs operate at a temperature of below 90°C because of limitations imposed by the thermal properties of the membrane itself.² The development of PEMFC technology is primarily sponsored by the transportation and portable power market sectors.

Solid oxide fuel cells are currently being demonstrated in various sizes from 1kW up to 250-kilowatt plants. SOFCs utilize a non-porous metal oxide (usually yttria-stabilized zirconia, Y_2O_3 -stabilized ZrO_2) electrolyte material. SOFCs operate between 650 and 1000°C, where ionic conduction is accomplished by oxygen ions (O^-).

Table 1 presents a summary comparison of the four primary fuel cell types that are under serious consideration for power generation applications. Notice that the higher temperature fuel cells do not require an external reformer. The PAFC and PEMFC units tend to use precious metal catalysts, while those of the MCFC and SOFC units are typically nickel-based. These differences lead to many differences in design and function, which will be described in more detail in the next section.

Table 1. Key features of the four fuel cell types used in power generation applications after Hirschenhofer et al. (1998).³ High temperature fuel cells highlighted.

Feature	MCFC	PAFC	PEMFC	SOFC
Electrolyte	Immobilized Molten Carbonate	Immobilized Phosphoric Acid	Ion Exchange Membrane	Ceramic
Typical Operating Temperature	600-650°C	200°C	80°C	600-1000°C
Charge Carrier	CO_3^-	H^+	H^+	O^-
External Reformer for natural gas	No	Yes	Yes	No
Prime Cell Components	Stainless Steel, nickel, carbonate salts	Graphite, Teflon, phosphoric acid	Carbon, plastics, special polymers	Ceramics, high temperature metals
Catalyst	Nickel	Platinum	Platinum	Nickel, Perovskites
Product Water Management	Gaseous Product	Evaporative	Evaporative	Gaseous Product
Product Heat Management	Internal Reforming + Process Gas	Process Gas + Independent Cooling Medium	Process Gas + Independent Cooling Medium	Internal Reforming + Process Gas

While any one of the above fuel cell types can be integrated into a hybrid gas turbine fuel cell cycle, the advantages of integration are most prominent with the high temperature fuel cells (i.e., MCFC and SOFC). This is due to the fact that a gas turbine engine can more effectively utilize the heat produced at the higher operating temperatures of MCFC and SOFC technology than it can that produced by other fuel cell types. In a complementary fashion, the MCFC and SOFC technologies can directly benefit from the pressure and temperature conditions (higher pressure and preheating of reactants) that a gas turbine engine can produce in an integrated hybrid cycle. As a result of this complementary operation, the focus of this chapter and all remaining discussion will be on hybrid systems that use high temperature fuel cells (MCFC and SOFC) only.

High Temperature Fuel Cells

High temperature fuel cells (HTFCs), such as solid oxide fuel cells and molten carbonate fuel cells are especially well suited for hybrid operation. The high operating temperature of these fuel cell systems allows integration with a gas turbine engine at a temperature that is mutually beneficial. Depending upon the design of the integrated hybrid system, waste heat from the fuel cell could be converted in the gas turbine engine to electricity or waste heat from the gas turbine could be put to good use preheating the reactants for the fuel cell or providing heat for fuel processing.

MCFC

The MCFC, also called a carbonate fuel cell, is one of the fuel cell technologies that has proven efficiency and environmental performance. In addition, significant reductions in carbonate fuel cell capital cost are expected in the near future. In particular, the use of carbonate fuel cells in the distributed power market is already significant and could offer an ideal solution to increased energy demands with concurrent expectations for reliability and environmental sensitivity.

The carbonate fuel cell concept involves conduction of carbonate ions (CO_3^-) within an immobilized mixture of molten carbonate salts. Other cell components are based on nickel and stainless steels, which contribute to initial capital cost, but, are significantly less expensive than the precious metal catalysts used in lower temperature fuel cells. Relatively inexpensive nickel (Ni) and nickel oxide (NiO) are adequate to promote reaction on the anode and cathode respectively at the high operating temperatures of an MCFC.⁴ Since the charge carrier is an oxidant, several fuel species can be oxidized within the anode compartment leading to inherently greater fuel flexibility. To-date, carbonate fuel cells have been operated on hydrogen, carbon monoxide, natural gas, propane, landfill gas, marine diesel, and simulated coal gasification products.

The typical operating temperature of a carbonate fuel cell is around 650°C. This temperature is almost ideal from the system perspective, since it allows higher Nernst potential (ideal Nernst potential increases with decreasing temperature) while still providing high temperature thermal energy sufficient to sustain and support reformation chemistry. Thus carbonate fuel cell system designs typically contain an internal reformer. The carbonate fuel cell demonstrations to-date, have therefore been able to show the highest fuel-to-electricity conversion efficiencies of any stand-alone fuel cell type.

The primary developer of carbonate fuel cell technology is FuelCell Energy Corporation, the developer and manufacturer of the Direct Fuel Cell™ concept. FuelCell Energy has demonstrated carbonate fuel cells from 10kW to 2MW of electrical output on a variety of fuels. Hitachi and IHI are also developing carbonate fuel cell technology for stationary power applications and have recently, successfully demonstrated carbonate fuel cell technology in Kawagoe, Japan. Ansaldo Ricerche has also demonstrated a 100kW carbonate fuel cell in Milan, Italy. Carbonate fuel cell systems have the highest fuel-to-electricity conversion efficiency (>50%) of any fuel cell type. In addition, carbonate fuel cell technology is expected to experience dramatic initial capital cost reductions in upcoming years. Carbonate fuel cell technology is more fuel flexible than lower temperature fuel cell technologies and is well suited to marine, military, and traction applications.

The high temperature thermal effluent of a carbonate fuel cell allows significant co-generation and/or integration with a heat engine cycle in hybrid applications. Several carbonate fuel cell hybrid systems with fuel-to-electricity efficiencies greater than 70% have been conceptualized with some under development today. Hybrid MCFC systems have been developed and tested by FuelCell Energy and Capstone Turbine in Danbury, Connecticut and in Japan.

SOFC

A SOFC is a *solid state* fuel cell constructed of ceramic materials (metal oxides) and metals. SOFCs share the solid state electrolyte feature with the proton exchange membrane fuel cell (PEMFC). Solid state construction offers the potential for increased reliability and durability with less corrosion and no need to manage electrolyte evaporation or circulation.

Typically the anode of an SOFC is nickel zirconia (Ni-ZrO_2) and the cathode is strontium-doped lanthanum manganite (Sr-doped LaMnO_3).⁵ SOFCs offer the stability and reliability of all-solid-state ceramic construction. High-temperature operation, up to 1,000°C, allows more flexibility in the choice of fuels and can produce very good performance in combined-cycle and hybrid applications. SOFCs approach 50 percent electrical efficiency in the simple cycle systems operated on natural gas, and 85 percent total thermal efficiency in co-generation applications.⁶

The SOFC concept involves conduction of oxygen ions (O^-) within the electrolyte at high temperatures (650-1000°C) making it inherently more fuel flexible than other fuel cell types. Whereas most other fuel cells are susceptible to carbon monoxide (CO) poisoning, SOFCs can use CO as a fuel to produce electricity. To-date, SOFCs have been operated on hydrogen, carbon monoxide, natural gas, propane, landfill gas, diesel and JP-8.

The high temperature operation of a SOFC has advantages and disadvantages. The advantages include the use of high temperature heat to reform hydrocarbon fuels to hydrogen(H_2)/carbon monoxide(CO) mixtures for direct use in the fuel cell. This reformation process

1.4 Hybrid Gas Turbine Fuel Cell Systems

requires heat to proceed. The high temperature heat also allows significant co-generation and/or integration with a heat engine cycle. The disadvantages of high temperature operation include the need to insulate the technology to protect from injury and the requirement of more costly materials of construction.

SOFCS have higher overall fuel-to-electricity efficiency than lower temperature fuel cells (e.g., PEMFC) operated on available hydrocarbon fuels (e.g., natural gas). When integrated with a heat engine cycle, efficiency can be increased even further. The hybrid SOFC cycle, which integrates a SOFC into a gas turbine cycle, offers the potential of fuel-to-electricity efficiencies in the 75-80% range. This remarkably high efficiency is unmatched by any other technology. Although in the early stages of development, hybrid designs and systems are now emerging with the first demonstration being accomplished by Southern California Edison and Siemens Westinghouse Power Corporation at the National Fuel Cell Research Center.

SOFC systems are being advanced by a number of companies and organizations with three major fuel cell stack designs emerging. The major design types are tubular, planar, and monolithic. Tubular SOFC designs are closer to commercialization and are being produced by Siemens Power Corporation, Mitsubishi Heavy Industries, Acumentrics, among others. The planar and the monolithic designs are at an earlier stage of development typified by sub-scale, single cell and short stack development (kW scale). More than 100 companies are advancing and commercializing SOFC technology around the world and especially in the U.S., Europe and Japan. Primary U.S. SOFC companies include GE, Acumentrics, FuelCell Energy, Versa Power, Ceramatec, Inc., Technology Management, Inc., SOFCo, Cummins, and Ztek, Inc., among others.

SOFC systems have been operated all over the world, proving SOFC performance and features. Examples include the tubular SOFC design of Siemens Westinghouse Power Corporation that has demonstrated over 85,000 hours of operation with low cell degradation, and the SOFCo planar SOFC design exhibiting power densities up to 1000W/l.

Because of the high potential of SOFC technology to produce robust (long lasting), high power density, fuel flexible, and low cost fuel cell systems, significant industry and agency investment is currently focused on SOFC technology, especially in Europe, Japan and the United States. Notably, the Solid State Energy Conversion Alliance of the U.S. Department of Energy includes six industry-led teams (General Electric, Siemens, Cummins, FuelCell Energy, Acumentrics, and Delphi) and a core technology research program including national laboratory and university researchers that is focused on developing low cost, high power density and robust SOFC technology.

Gas Turbine Technology for Hybrid Applications

A typical hybrid system recovers the thermal energy in the fuel cell exhaust and converts it into additional electrical energy through a heat engine. Several heat engines have been considered for this type of system including gas turbines, steam turbines and reciprocating engines. The only conversion device that has been tested in this role to-date is a micro-gas turbine (or micro-turbine generator, MTG). An MTG is a type of gas turbine engine that is particularly amenable to integration with a high temperature fuel cell in a hybrid system. This is due to several features of an MTG that are well matched to the requirements of the high temperature fuel cell in the hybrid system such as:

- MTGs require relatively low turbine inlet temperature, which can be supplied by the exhaust of a high temperature fuel cell,
- MTGs operate at relatively low pressure ratios that are amenable to either direct use in the high temperature fuel cell or in other components of the hybrid system,
- MTGs often use recuperation to improve efficiency, which introduces components and features (e.g., heat exchangers, large gas volume between compressor and turbine) that make the gas turbine engine design more amenable to a hybrid cycle,
- The fuel cell can be operated under pressurized conditions improving its output and efficiency,
- Sufficient thermal energy is contained in the fuel cell exhaust to power an MTG compressor (for fuel cell pressurization) and an electric generator (to produce additional electricity),
- The current size of most fuel cell systems is relatively small (between 250kW and 1.5 MW), which matches well with the smaller output MTG,
- The power density of the system can be increased, and
- Overall system cost is potentially lower on a \$/kW basis (primarily due to the increased output from the fuel cell).

Note that the gas turbine engine characteristics noted above as desirable for hybrid applications are not necessarily those that are desired for stand-alone gas turbine engines. Usually one desires higher turbine inlet temperatures and higher pressure ratios to improve the performance of a gas turbine engine. In hybrid cycles with a high temperature fuel cell, the gas turbine engine is not required to operate at either high pressure ratios or with high turbine inlet temperature making the performance characteristics of the gas turbine relatively simpler to achieve. That is, less sophisticated gas turbine technology may be all that is required for a hybrid system, although improvements in compressor and turbine efficiency etc. are still desirable.

Although the MTG is currently well-suited for integration into hybrid gas turbine fuel cell systems, future high temperature fuel cell technologies may become large and able to withstand significantly higher pressures. Analyses have shown that synergistic effects of the combined gas turbine fuel cell system lead to electrical conversion efficiencies of 72-74 percent (LHV) for systems under 10 MW, whereas efficiencies greater than 75% could be achieved with larger systems. As fuel cells advance and scale-up and pressurization of MCFC and/or SOFC technology becomes viable, larger and more sophisticated gas turbine engines (e.g., axial compressors and turbines, higher pressure ratios, high turbine inlet temperature) will be required.

1.4-4 Hybrid Gas Turbine Fuel Cell Concept

The gas turbine fuel cell hybrid system was first conceived in the mid-1970s. By 1998 over ten hybrid concepts had been patented, offering variations in fuel cell type, in the position of the components in the integrated system, and in system operating pressure. The basic concept of a hybrid gas turbine fuel cell system is illustrated in Figure 4 where a fuel cell replaces the combustor of a typical Brayton (gas turbine) cycle. This leads to direct fuel-to-electricity production from the fuel cell (in the place of chemical-to-thermal energy conversion of a combustor) with the waste heat of the fuel cell being used to provide all compression power and additional electricity through a turbo-generator. Note that electrochemical production of electricity lowers emissions and increases efficiency and as a result around 80% of the electricity is produced via electrochemistry in the fuel cell with the remainder being produced in the turbo-generator.

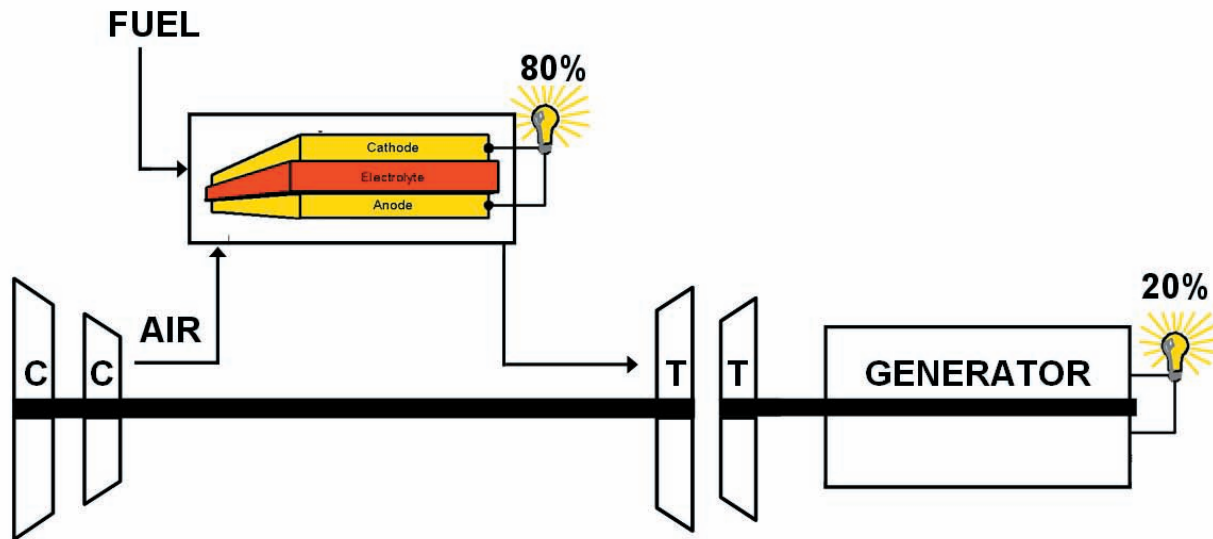

Fig. 4. Basic design concept of a hybrid gas turbine fuel cell system

System studies have been carried out for the U.S. DOE and others for hybrid systems up to 300 MWe capacity (using 40 MWe power blocks). In 2000 the first tests and demonstrations of hybrid gas turbine fuel cell systems began with efforts in the U.S. and Japan. Both MCFC and SOFC hybrid systems have been built and tested each proving the potential for such systems to achieve high efficiency and low emissions production of electricity from natural gas. To-date five hybrid gas turbine fuel cell systems have been tested, each using a different design concept.

Hybrid Design Concepts

The basic design goal of a hybrid system is to integrate two or more energy conversion devices—or two or more fuels for the same device—into a single system that provides benefits in terms of fuel flexibility, efficiency, availability, economics or sustainability that either of the devices alone could not provide. Synergy is the term often used to describe hybrid systems since the components when integrated are complementary and lead to combined performance characteristics that are greater than the sum of the individual elements. In the particular case of a gas turbine fuel cell hybrid system the primary design concepts are as follows:

- (1) convert most of the fuel by electro-oxidation in the fuel cell leading to low emissions of criteria pollutants and relatively high fuel-to-electricity conversion efficiency,
- (2) use fuel cell heat and turbine exhaust heat elsewhere in the system (e.g., fuel processing, reactant preheating, provide compression power) in a manner in which overall efficiency is enhanced,
- (3) use the high pressure produced by the gas turbine in a manner that improves fuel cell output and efficiency (if possible), and
- (4) use the separated fuel and oxidant streams of the fuel cell to enhance other features (e.g., CO₂ sequestration, fuel production) of the hybrid cycle (if possible).

Synergy can be realized in hybrid cycles in many ways, as indicated by the last two concepts introduced above. The operation of a fuel cell at the high pressure conditions between the compressor and turbine of a gas turbine engine leads both to an increase in the fuel cell power output (for the same fuel cell stack) and a reduction in some of the electrochemical losses leading to higher efficiency (most notably improving electrochemical kinetics). In addition, the fact that a fuel cell operates with separated fuel and oxidant streams provides multiple opportunities for enhanced hybrid cycle performance from easier sequestration of a higher concentration CO₂ stream to significant potential for hydrogen and/or synthetic hydrocarbon fuel production. These synergistic aspects of hybrid gas turbine fuel cell systems are of particular interest and are part of the reason why analyses and testing to-date has determined that such hybrid systems have great promise.

1.4 Hybrid Gas Turbine Fuel Cell Systems

Hybrid System Configuration

The fuel cell and gas turbine of a hybrid system can be configured in several different fashions with a myriad of potential cycle configurations that are possible. Four basic parameters can be defined that provide a means of characterizing the hybrid system configurations. The parameters are:

- (1) Fuel cell topping cycle,
- (2) Fuel cell bottoming cycle,
- (3) Direct hybrid cycle, and
- (4) Indirect hybrid cycle.

Most hybrid cycles that have been conceived and studied to-date can be characterized using these four parameters.

A fuel cell “topping” cycle is one in which the gas turbine is considered the balance of plant (BOP) with the turbo-machinery placed downstream of the fuel cell in the cycle. The basic design concept presented in Figure 4 represents this type of fuel cell topping cycle. Essentially fuel cell topping cycles use a fuel cell in the place of a combustor in the typical Brayton cycle, and the turbine is placed downstream of fuel cell. The turbine uses the fuel cell exhaust to produce compressive power and additional electricity while the fuel cell is the primary electricity generator.

A fuel cell “bottoming” cycle is one in which the gas turbine turbo-machinery resides upstream of the fuel cell. The fuel cell is placed downstream of turbine and uses the gas turbine exhaust as its air supply stream. Typically the fuel cell remains the primary generator. This type of bottoming cycle is particularly well-suited to the MCFC since this type of fuel cell requires carbon dioxide in the oxidant stream (to make the carbonate ions), which can be provided by an upstream gas turbine engine combustor.

In a “direct” hybrid cycle flow from upstream elements is directly used in downstream elements of the cycle. Heat exchangers to de-couple to two cycles are not required, but may be used for other purposes. The fuel cell of a direct hybrid cycle is typically operated at pressurized conditions extant between the compressor and turbine of the gas turbine. This presents more significant challenges with control and with fuel cell operation and degradation. However, direct hybrid cycles typically have higher efficiency than indirect hybrid cycles.

An “indirect” hybrid cycle uses devices (usually heat exchangers) to de-couple the gas turbine and fuel cell components of the system so that flow from upstream components does not enter downstream components. Thermal integration of the cycle involves more losses (e.g., in the additional heat exchangers) and the fuel cell is typically operated at atmospheric pressure. This leads to a less challenging system to control and operate and lesser challenges for fuel cell operation and degradation. However, indirect hybrid cycles tend to be less efficient than direct cycles and the cost and size of heat exchanger components can be considerable.

Figure 5 presents an example of a direct hybrid gas turbine fuel cell topping system configuration in which the fuel cell is operated in-between the compressor and turbine of the gas turbine engine. Note that a recuperator (heat exchanger) is still used in this cycle configuration to preheat the fuel and air before it enters the fuel cell.

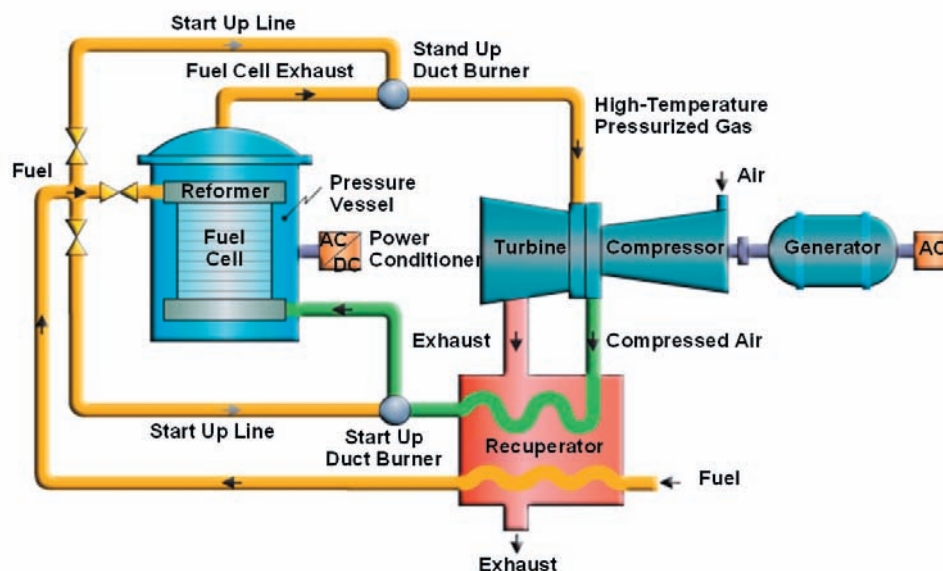

Fig. 5. Schematic of a direct hybrid gas turbine fuel cell topping cycle

Source: See note 7.

1.4 Hybrid Gas Turbine Fuel Cell Systems

In 1999 the turbines program funded a study by Rolls Royce with the goal to produce a turbo-generator, which would cost approximately \$400/kW. When coupled with fuel cells, the turbine would produce approximately 25% of the power for a hybrid in the 1 MW to 5 MW class. The gas turbine would be capable of providing pressurization from 5 pressure ratio (PR), to approximately 15 PR and higher, all from the same special purpose gas turbine system design. As a stand-alone device, the turbine would produce 1.5 MW of electric power in a simple cycle mode, without the need of a recuperator (recuperators are not needed in mini-turbines to achieve 30% efficiency, which reduces costs by 25-30%, reduces space requirements, and contributes to more reliable operation). In the stand-alone mode, its efficiency would be approximately 33% (comparable to larger 5 MW class gas turbines). The exhaust energy could be used to operate a combined heat and power cycle.

Detailed and Experimental Studies

After these studies were completed several tests of the hybrid concept were initiated by the U.S. Department of Energy with industry cost-sharing from FuelCell Energy, General Electric (formerly Honeywell), and Siemens Power Corporation (formerly Siemens Westinghouse). Each of the projects focused on the sub-1MW class hybrid system.

FuelCell Energy's hybrid system is comprised of a 250 kW fuel cell stack and a 30 kW Capstone micro-turbine in an indirect fuel cell bottoming configuration. The sub-MW system tests have provided valuable data that has proven the high efficiency and low emissions performance of such systems. FuelCell Energy also designed a 40 MW fuel cell turbine hybrid power system in this effort.

The General Electric project includes the sub-MW design and test of a Solid State Energy Conversion Alliance (SECA) solid oxide fuel cell and a micro-turbine. The project evaluated several turbine cycle configurations, including topping, bottoming, direct and indirect, and allowed for the evaluation of integration and scale-up issues for SECA-based hybrid systems.

The Siemens Power Corporation hybrid design included a 100 kW tubular SOFC integrated with a 60 kW Ingersoll Rand micro-turbine generator. This system was built and tested at the National Fuel Cell Research Center, in Irvine, California. In this test the hybrid direct gas turbine fuel cell topping cycle configuration was demonstrated. This test included pressurization of the fuel cell to provide a total of 220 kW of power from the hybrid system. Testing proved that high efficiency and ultra-low emissions was achievable with these types of hybrid cycles, but, that integration and operation is considerably difficult with such complex hybrid systems.

Early optimism regarding the ease of integrating fuel cells with off-the-shelf micro-turbines has been tempered by technical issues encountered in the test program at the National Fuel Cell Research Center. It is now recognized that integrating fuel cells and turbines is challenging. Existing gas turbines do not match the pressure ratios, mass flows, and other critical operating and performance parameters of the small high temperature fuel cells that are currently available. Nonetheless, the early tests have proven the high efficiency and ultra-low emissions performance characteristics of hybrid gas turbine fuel cell technology so that optimism regarding the potential of these types of cycles to significantly contribute to future energy demands remains high.

Detailed Paper Studies for Future Hybrid Systems

Additional studies on hybrid systems and the results of recent tests identified significant potential benefits from a combined fuel cell/turbine power system. These benefits include the ability to achieve net electrical efficiencies in the 70 % + range, to configure systems in the 20 MW to 40 MW and larger size range, and to significantly surpass emission standards for criteria pollutants while reducing the emissions of CO₂ / kW-hr. Studies also predict lower cost of electricity and lower capital costs than alternative power generation systems. For example, a market study by Research Dynamics Corporation suggested that such products could compete on a cost-of-electricity basis with other DG technologies and capture 8.2 GW of market share by 2005.

The historical record of the evolution of hybrid gas turbine fuel cell technology has been documented by White⁹, and the various technical elements of the hybrid technology have been presented in a series of sessions sponsored by the American Society of Mechanical Engineers (ASME) International Gas Turbine Institute (IGTI).¹⁰

Under the sponsorship of the U.S. DOE, a multi-disciplinary team led by the Advanced Power and Energy Program (APEP) of the University of California, Irvine is defining the system engineering issues associated with the integration of key components and subsystems into central power plant systems that meet stretch performance and emission goals for both natural gas and coal fuel operation. The myriad of fuel processing, power generation, and emission control technologies are narrowed down to selected scenarios in order to identify those combinations that have the potential to achieve high efficiency and minimized environmental impact while using fossil fuels. The technology levels considered are based on projected technical and manufacturing advances being made in industry and on advances identified in current and future government supported research. Examples of systems included in these advanced cycles are high-temperature fuel cells, advanced gas turbines, ion transport membrane separation and hydrogen-oxygen combustion.

The overall objectives of DOE study were to (1) produce electricity and transportation fuels at competitive costs, (2) minimize environmental impacts associated with fossil fuel use, and (3) attain high efficiency. The efficiency target for natural gas fueled plants was 75% on a LHV basis while that for coal fueled plants was 60% on an HHV basis. All cycles were to include producing electricity with the potential for CO₂ capture and sequestration and co-production of transportation fuels. This study determined that the only technology that could meet these goals is hybrid gas turbine fuel cell technology.¹¹

1.4-6 Dynamic Simulation of Hybrid Systems

In both thermodynamic simulation and experiment hybrid gas turbine fuel cell systems have demonstrated lower environmental impact and higher efficiency compared to conventional combustion driven power plants. Lower carbon dioxide emissions can be achieved through higher fuel-to-electrical efficiencies, while NO_x and other criteria pollutant emissions are greatly reduced by primary electrochemical conversion of the fuel versus the combustion process of conventional plants.

Understanding of the dynamic performance of hybrid systems is important to the advancement of the technology and the development of controls for future systems. In this section, a dynamic model of a hybrid system is described and applied to analyze a specific hybrid cycle that is applicable to distributed generation. More complex cycles have been considered for larger scale power plants that may utilize a combined cycle to drive the efficiency up and the environmental impact down.¹²

Today much work is being done to reduce the cost and increase the reliability of SOFC systems. Several cell geometries are being advanced by fuel cell manufacturers including tubular and planer SOFC designs, and even cell geometries that combine planer and tubular features. Each geometry has its advantages and disadvantages with regard to thermal expansion compliance, power density, potential cost, manufacturability, and internal resistivity.¹³ Many companies are advancing these different types of SOFCs, but no commercial products exist today. Only demonstration and prototype systems have been built and tested to-date.

Mathematical models provide a cost effective and efficient tool in aiding the development of SOFCs and SOFC/GT systems. Several entities around the world have developed steady state simulation capabilities for FC/GT systems. These research groups include efforts at the Georgia Institute of Technology, University of Genova, NFCRC, Nanyang Technical University and others.¹⁴ Dynamic gas turbine fuel cell simulation capabilities are less common, but increasingly being developed as the demand for dynamic understanding and controls development grows. Examples of previous dynamic simulation efforts include work at the National Energy Technology Laboratory, and FuelCell Energy among others.¹⁵ Model evaluation is very important and there remains a great need to produce experimental hybrid system data.

To-date there have been two hybrid systems built and successfully demonstrated. An indirect bottoming cycle (with respect to the FC) has been built and demonstrated by FuelCell Energy that integrated a molten carbonate fuel cell and a Capstone C30 gas turbine. This system successfully ran for 2900 hours in grid-connected mode at 51.7% fuel-to-electrical efficiency. See Ghezel-Ayagh¹⁶ for more information on this system. The second system was a direct topping cycle (with respect to the FC), which is the system of direct interest to the current work.

Experiment Description

Siemens Power Corporation developed the very first pressurized SOFC/GT hybrid system using their tubular SOFC stack design. This system, presented in Figure 7, was tested at the NFCRC with support from Southern California Edison, the U.S. Department of Energy and others. The system was designed, constructed and tested to demonstrate and prove the hybrid concept. The system operated for over 2900 hours and produced up to 220 kW at fuel-to-electricity conversion efficiencies of up to 53%. In parallel, NFCRC developed dynamic simulation capabilities for each of the system components together with a simulation framework for modeling and developing control strategies for integrated SOFC/GT systems.



Fig. 7. Pressurized 220 kW SOFC/Gas Turbine Hybrid

1.4 Hybrid Gas Turbine Fuel Cell Systems

A diagram of the integrated SOFC/GT system is presented in Figure 8. This system is comprised of a tubular SOFC with integrated internal reformer and anode off-gas oxidizer as illustrated in Figure 9. These components (stack, reformer) are placed between the compressor and turbine so that they operate under pressurized conditions. The gas turbine is a dual shaft Ingersoll-Rand 75 kW gas turbine. The integrated cycle also includes a recuperative heat exchanger and a separate turbine generator set (see Figure 8). Note that there are also two bypass valves that can divert flow around the heat exchanger and around the SOFC.

Dynamic and steady state data were gathered during operation. Nominally the SOFC produced 180 kWe while the GT produced 40kWe of the total power. The dynamic data produced by the SOFC/GT system was primarily gathered during start-up and shutdown. The primary goal of the experimental effort was to demonstrate the hybrid concept for 3000 hours of steady state operation without detailed investigation of dynamic responses to perturbations.

Under nominal operating conditions the SOFC stack was pressurized to three atmospheres, resulting in improved performance (through better electrode kinetics) and increased output (through increased Nernst potential of higher reactant partial pressures). The SOFC stack produces 100 kWe at atmospheric pressure, whereas in the hybrid configuration it produced as much as 180 kWe. A more detailed description of the system is presented in other works.¹⁷

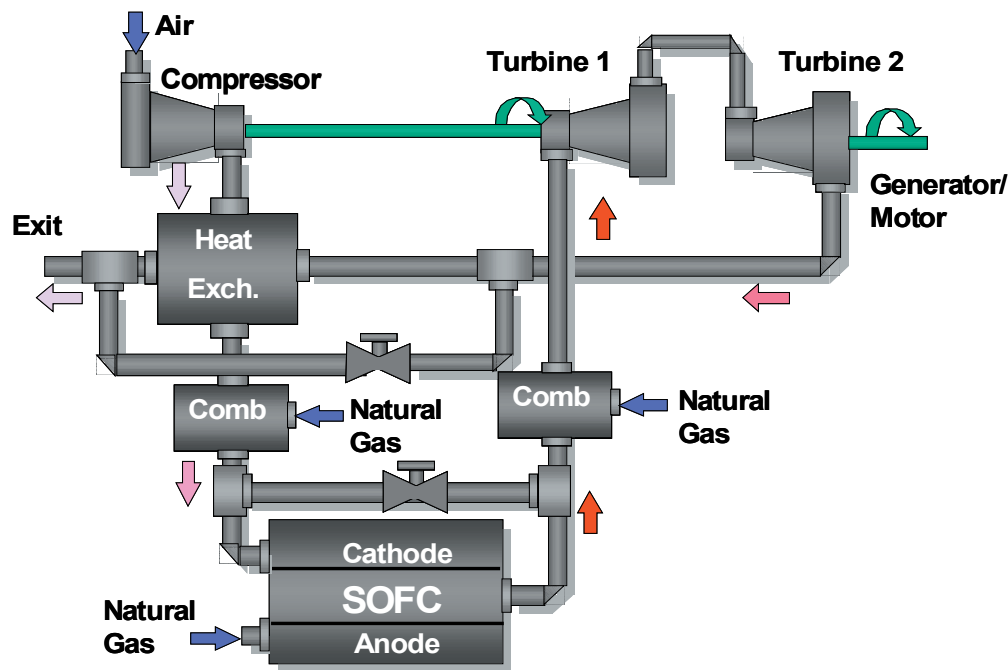

Fig. 8. Diagram of the pressurized 220 kW SOFC/gas turbine hybrid system

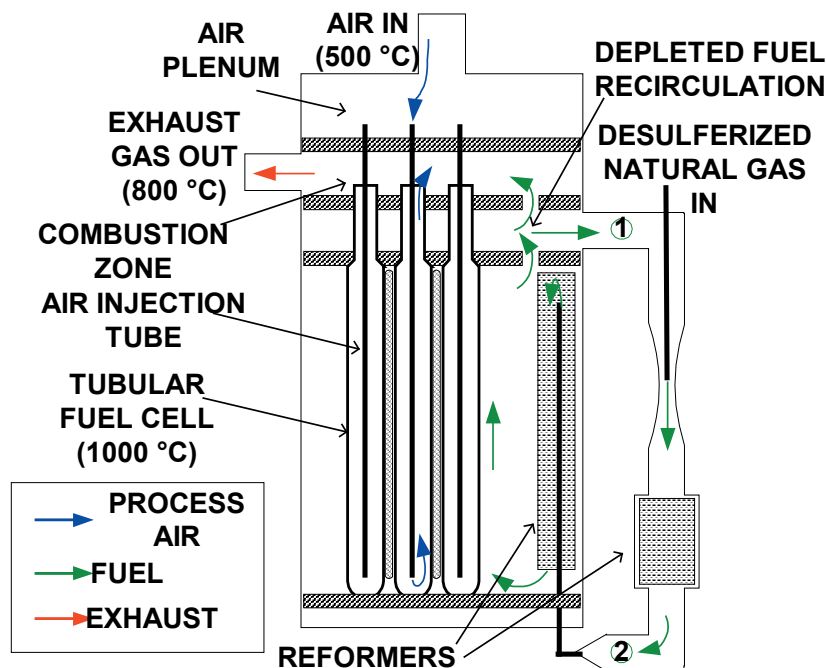

Fig. 9. Tubular SOFC stack design.

Dynamic Model Description

The equations that govern the dynamic performance of or each of the system components are solved in a modular fashion for each of the components of the 220 kW hybrid system in a Matlab/Simulink™ format. The models were designed and constructed to be reliable and robust. All of the models are based on the fundamental mass, momentum, and energy conservation equations plus detailed solutions of electrochemical, chemical, and heat transfer processes.

SOFC Model

The SOFC model developed for the current application is a simplified bulk model that simulates the overall performance of a pressurized tubular SOFC. The current model does not capture the spatial variations of operating parameters throughout the SOFC stack. This simplified model is deemed sufficient for simulating a complete hybrid system. However, spatially resolved models may be required to more accurately simulate the performance of specific SOFC stack designs and to garner more insights into stack behavior. Such models have been developed previously at the NFCRC and will be considered for future integration in a full hybrid system model.¹⁸

The governing equations of the SOFC model are introduced, starting with the Nernst potential EQ(1), which provides the reversible cell potential for a given fuel and oxidant composition.

$$E = E_0 + \frac{R_u T}{2F} \ln \left(\frac{\mathbf{X}_{H_2} \mathbf{X}_{O_2}^{1/2}}{\mathbf{X}_{H_2O}} P_{CATHODE}^{1/2} \right) \quad (1)$$

While EQ(1) solves for ideal cell potential, the actual cell potential for any fuel cell under real operating conditions will be reduced due to irreversibilities referred to as polarizations or overpotential losses.

The modeling of realized cell voltage can be achieved by calculating each of the three primary overpotentials (activation, ohmic, and concentration) in bulk fashion and subtracting them from the ideal Nernst potential as in EQ(2)

$$V_{cell} = E - \eta_A - \eta_C - \eta_R, \quad (2)$$

where V_{cell} is the actual cell voltage for a given current, η_A is the activation polarization loss, η_C is the concentration polarization loss, and η_R is the ohmic polarization loss. Calculation of these polarizations is based on a first principles understanding of the overall performance of a fuel cell. For a given temperature and pressure, all three polarizations are typically only a function of current demand.

The loss associated with sluggish kinetics due to low temperatures and/or lack of availability of active catalytic cell sites is modeled using a relationship for activation polarization. This polarization is more dominant at low current densities. The activation polarization is calculated as

$$\eta_A = \frac{R_u T}{\alpha n F} \ln \left(\frac{i}{i_0} \right). \quad (3)$$

The key parameter that determines activation polarization for a specific fuel cell is i_0 , which is the exchange current density. Exchange current density is associated with the catalytic activity of a particular cell and corresponds to the rate at which the electrodes exchange ions with the electrolyte under equilibrium conditions (no net current flow). α represents the distribution of intermediate species at the triple phase boundary, indicating whether these species more closely resemble reactants or products. α has a value between zero and one (usually taken to be 0.5).

The irreversibility associated with concentration gradients near the active cell surface is modeled by EQ(4)

$$\eta_C = -\frac{R_u T}{n F} \ln \left(1 - \frac{i}{i_L} \right). \quad (4)$$

The new term here is i_L , which is the limiting current density. Limiting current density corresponds to the maximum current that the fuel cell can produce to equal the maximum supply speed of reactants. To avoid this polarization, the fuel cell is usually operated at lower current densities or at higher pressures (if power density is a concern).

Since activation polarization is reduced at high temperature, and since high temperature fuel cells are typically operated at relatively low current density, ohmic polarization is usually the most significant electrochemical loss. At normal operating conditions, this ohmic loss is primarily due to low ionic conductivity of the electrolyte and/or low electrical conductivity of associated interconnect materials. Resistance can also be high, if the cell is operating at a temperature below the optimum due to the strong temperature dependence of electrolyte ionic resistivity. The potential loss associated with cell resistance is

1.4 Hybrid Gas Turbine Fuel Cell Systems

$$\eta_R = iR_{eff}, \quad (5)$$

where i is the current density and R_{eff} is the effective overall cell resistance. Several fuel cell parameters affect the cell resistance including inherent electrolyte ionic conductivity, electrolyte thickness, electrode and interconnect electronic conductivities and geometry of the electrolyte affects the internal resistance. Thinner electrolyte layers can be designed to reduce ionic ohmic polarization, but the thickness is bound by the requirements of the cell to endure structural stresses produced by different thermal expansion of the materials that are sandwiched together. The effective resistance used in the current model includes consideration of the cell materials and geometry as well as a temperature dependence that is based on empirical data gathered from test cell and laboratory experiments on the tubular SOFC design of Siemens Westinghouse.

The SOFC model incorporates the dynamic equations that solve for conservation of mass or species, momentum, and energy. For species conservation the equation assuming a well-stirred reactor approach is used.

$$V_{cv} C \frac{dX}{dt} = \dot{N}_m (X_m - X) - X \sum R + R \quad (6)$$

There are seven species considered: methane, carbon monoxide, carbon dioxide, hydrogen, water, nitrogen, and oxygen. Using Faraday's law of electrolysis EQ(7) the electrochemistry vectors for the reaction rates in the SOFC anode and cathode become equations EQ (8) and EQ (9) for the anode and cathode respectively.

$$r_j = \frac{a^* i}{nF} \quad (7)$$

$$\mathbf{R}_{anode,e} = A_{Cell} * \begin{bmatrix} 0 & 0 & 0 & -\frac{i}{2F} & +\frac{i}{2F} & 0 & 0 \end{bmatrix} \quad (8)$$

$$\mathbf{R}_{cathode,e} = A_{Cell} * \begin{bmatrix} 0 & 0 & 0 & 0 & 0 & 0 & -\frac{i}{4F} \end{bmatrix} \quad (9)$$

Reformation and water-gas-shift chemical reactions occur simultaneously with the electrochemical reactions in the anode compartment of the SOFC. The reaction vector for the internal reformation chemical reactions is added to the electrochemistry reaction vector and inserted into EQ(6) to solve for dynamic species conservation.

The internal reformation model considers the chemical kinetics of three concurrent chemical reactions, steam reformation of methane and water-gas shift as follows:

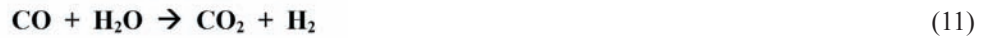

The forward rates of these steam reformation and water-gas shift are determined by Arrhenius rate expressions. The reformation model uses rates that are consistent with the use of typical nickel-based catalysts.¹⁹ This should be reasonable considering the nickel-YSZ composition of the cathode and nickel felt electrical connection materials in the anode compartment. The rate equation of reaction EQ(10) is

$$R_1 = k_1 \left(\frac{P_{CH_4} P_{H_2O}}{P_{H_2}^{2.5}} - \frac{P_{CO} P_{H_2}^{0.5}}{K_{p1}} \right) / DEN^2 \quad (13)$$

The rate of reaction EQ(11) is

$$R_2 = k_2 \left(\frac{P_{CO} P_{H_2O}}{P_{H_2}} - \frac{P_{CO_2}}{K_{p2}} \right) / DEN^2 \quad (14)$$

The rate of reaction EQ(12) is

$$R_3 = k_3 \left(\frac{P_{CH_4} P_{H_2O}^2}{P_{H_2}^{3.5}} - \frac{P_{CO_2} P_{H_2}^{0.5}}{K_{p3}} \right) / DEN^2. \quad (15)$$

The denominator used in each of the reaction rate expressions above is:

$$DEN = 1 + K_{CO} P_{CO} + K_{H_2} P_{H_2} + K_{CH_4} P_{CH_4} + \frac{K_{H_2O} P_{H_2O}}{P_{H_2}} \quad (16)$$

According to the Arrhenius equation and van't Hoff equation, the reaction constants k_i ($i=1-3$) and K_j ($j=CO, CH_4, H_2O, \text{ or } H_2$) in the above equations can be calculated from the pre-exponential factors A_i and A_j , and the absorption parameters E_i and ΔH_j from the following equations

$$k_i = A_i \exp\left(-\frac{E_i}{RT}\right), \quad (17)$$

$$K_j = A_j \exp\left(-\frac{\Delta H_j}{RT}\right). \quad (18)$$

The constants used in the current model are presented in Table 3 and Table 4. CO is assumed to be consumed/created only by water-gas shift and steam reformation. Direct electrochemical oxidation of CO and hydrocarbons is possible under current anodic conditions, but it occurs at a sufficiently slow rate that this assumption has been shown to be reasonable in previous studies.²⁰

Table 3. Reformation constants

Rate Constant	Activation energy (kJ/mol)	Pre-exponential factor	Rate Constant	Heat of adsorption (kJ/mol)	Pre-exponential factor
k_1	240.1	1.336×10^{15} (kmol·MPa ^(0.5) /kg _{cat} ·h)	K_{CO}	-70.65	8.23×10^{-4} (MPa ⁻¹)
k_2	67.13	1.955×10^7 (kmol/kg _{cat} ·h·MPa)	K_{CH_4}	-38.28	6.65×10^{-3} (MPa ⁻¹)
k_3	243.9	3.22×10^{14} (kmol·MPa ^(0.5) /kg _{cat} ·h)	K_{H_2O}	88.68	1.77×10^5 (unitless)
			K_{H_2}	-82.9	6.12×10^{-8} (MPa ⁻¹)

Table 4. Equilibrium constants

Equilibrium constant	Dimensions
$K_{p1} = 1.198 \times 10^{11} \cdot \exp(-26830/T)$	(MPa) ²
$K_{p2} = 1.77 \times 10^{-2} \cdot \exp(4400/T)$	(MPa) ⁰
$K_{p3} = K_{p1} \cdot K_{p2}$	(MPa) ²

1.4 Hybrid Gas Turbine Fuel Cell Systems

The SOFC model solves for the energy balance between the anode and cathode gas streams and the fuel cell materials. The cell materials (electrode-electrolyte assembly) the energy balance is solved using EQ(19). There is heat generated within the porous fuel cell electrode-electrolyte assembly where the hydrogen is being electrochemically oxidized. Based on the lower heating value of hydrogen, the energy that is not being converted to electrical energy produces heat in the SOFC stack as in EQ(20).

$$\frac{d\rho C_{mass} TV_{cv}}{dt} = \dot{E}_{in} - \dot{E}_{out} + Q_{GEN} \quad (19)$$

$$Q_{GEN} = \left(\frac{\Delta H_{f,H_2O(g)}}{nF} - V_{CELL} \right) * i \quad (20)$$

As for the anode and cathode gases, EQ(21) solves the energy balance for each of these control volumes.

$$\frac{dCC_{v,molar} TV_{cv}}{dt} = \dot{E}_{in} - \dot{E}_{out} \quad (21)$$

The gas stream flows are assumed to be fully developed laminar flow. This assumption permits the use of an altered form of the Darcy equation EQ(22) for the solution of momentum conservation (calculating the fuel cell pressure drop) as follows

$$\Delta P = f \frac{L}{D_h} \frac{\rho v^2}{2} \quad (22)$$

where ΔP is the pressure drop, f is the friction factor, L is the characteristic length, ρ is density, v is average velocity, and D_h is the hydraulic diameter.

Heat Exchanger and Combustor Model

The recuperator heat exchanger, SOFC heat exchanger, and combustor models are one dimensional in the streamwise direction. The heat exchangers solve the conservation equations for mass, momentum, and energy. The same equations EQ(19), EQ(21), and EQ(22) are used for the heat exchangers and combustor models except that there is no heat generation in the heat exchanger models.

Gas Turbine Model

A transient mathematical model of a gas turbine system has been developed using in the same Matlab/Simulink™ framework. The model predicts the behavior of a lumped parameter compressor and expander attached via rotating shaft. The dynamic expressions that account for gas compressibility and mass storage are solved in separate diffuser volumes as depicted in Figure 10. A generator load can be applied to the shaft or the system can operate as a turbo-charger.

The current one-dimensional lumped parameter approach is flexible to allow the incorporation of semi-empirical data from a specific production or prototype gas turbine. The semi-empirical data that is used in the current dynamic gas turbine modeling approach is in the form of non-dimensionalized compressor and turbine “maps.” These compressor and turbine maps provide steady state mass flow, pressure ratio, and efficiency as a function of rotational speed. Usually two maps each are required for the compressor and turbine. The first map plots the pressure ratio versus dimensionless mass flow for a series of fixed (sometimes non-dimensionalized) rotational speeds. The second map gives the normalized isentropic efficiency versus dimensionless mass flow for a series of fixed (sometimes non-dimensionalized) rotational speeds.

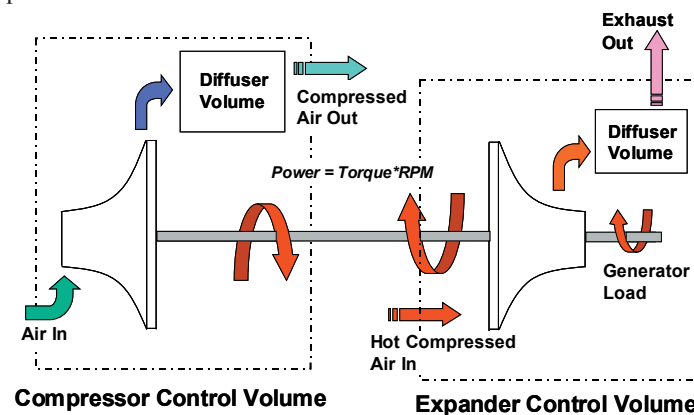

Fig. 10. Schematic approach to dynamic simulation of a gas turbine engine

Typical non-dimensionalization of the mass flow is as follows:

$$\frac{\dot{m}R\sqrt{\gamma RT_{01}}}{D^2 P_{01}} \quad (23)$$

where \dot{m} is the fluid mass flow, R is the gas constant, γ is the ratio of specific heats, T_{01} is the stagnation temperature at the inlet, D is a characteristic length, and P_{01} is the stagnation pressure at the inlet. Dimensionless rotor speed can be given by

$$\frac{ND}{\sqrt{\gamma RT_{01}}}, \quad (24)$$

where N is the rotational speed.

Using the mapped compressor and turbine performance, the mass flow through such can be determined for any given speed, discharge pressure, and inlet condition. The solution strategy for both the turbine and compressor dynamics involves iterative determination of mass flow. For a given rotational speed and pressure ratio, a mass flow is guessed and iteratively converged upon until a pressure ratio matches the ratio of discharge pressure to inlet pressure. An iterative approach is necessary because the discharge pressure is determined by the swallowing capacity of components downstream of the compressor (or turbine). Once the mass flow is determined, a compressor (or turbine) efficiency can be determined from the efficiency map. Knowing the isentropic efficiency, the compressor (or turbine) exit temperature can be determined from the isentropic relations described in the following paragraphs.

The inlet temperature of the compressor is known and once the compressor isentropic efficiency is extracted from the performance maps the compressor stagnation exit temperature, T_{02} , can be calculated by the using EQ(25).

$$T_{02} = T_{01} \left(1 + \frac{1}{\eta_{comp}} \left(\left(\frac{P_{02}}{P_{01}} \right)^{\frac{\gamma-1}{\gamma}} - 1 \right) \right) \quad (25)$$

The specific heat, C_p , is calculated next as a function of temperature based on third-order curve fits for a gas mixture containing up to seven molecular species (CH_4 , CO , CO_2 , H_2 , H_2O , N_2 , O_2). Using C_p and the temperature of each state the enthalpies can be calculated by EQ (26) and used to calculate the compressor work using EQ (27).

$$h_{01} - h_{02} = \int_{T_{02}}^{T_{01}} C_p(T) dT \quad (26)$$

$$P_C = \dot{m}_{Comp} (h_{01} - h_{02}) \quad (27)$$

After the compressor exit state is determined a dynamic expression that accounts for gas compressibility and mass storage in a separate compressor diffuser volume is solved as follows

$$\frac{dP}{dt} = (\dot{m}_{in} - \dot{m}_{out}) \frac{\gamma RT}{V} \quad (28)$$

Thus, for a given moment in time, all the parameters necessary to assess the dynamic compressor performance are calculated.

As for the gasifier turbine work or the turbine supplying work to compressor the turbine inlet temperature (T_{03}) is known. Using performance maps the isentropic turbine efficiency can be extracted from the turbine efficiency map and used in EQ(29) to calculate the turbine exit temperature.

$$T_{04} = T_{03} \left(1 + \eta_T \left(\left(\frac{P_{04}}{P_{03}} \right)^{\frac{\gamma-1}{\gamma}} - 1 \right) \right) \quad (29)$$

Once the temperatures are known then turbine mass storage can be assessed by solution of EQ (28) for the turbine. Then the enthalpies at each state (EQ(30)) are calculated in order to calculate the turbine power using EQ (31).

$$h_{03} - h_{04} = \int_{T_{04}}^{T_{03}} C_p(T) dT \quad (30)$$

$$P_T = \dot{m}_{Comp} (h_{03} - h_{04}) \quad (31)$$

1.4 Hybrid Gas Turbine Fuel Cell Systems

The above calculations are performed at every time step in the gas turbine transient model. To capture the dynamics associated with the rotational inertia of the GT, the summation of torques is used to calculate the angular acceleration, which is integrated over time to calculate the shaft speed of the gasifier turbine. Equation (32) is solved with the known turbine and compressor powers and rotational inertia, J , and rotational speed, ω , of the turbo machinery as follows:

$$\frac{d\omega}{dt} = \frac{1}{J\omega} (P_{T_1} - P_C) \quad (32)$$

For the second turbine (power turbine) the same equations are used for to calculate the state (5 and 6) temperatures and enthalpies. As for the sum of the torques, the second shaft has the generator load instead of the compressor load as in EQ (33).

$$\frac{d\omega}{dt} = \frac{1}{J\omega} (P_{T_2} - P_{LOAD}) \quad (33)$$

The generator operates at 3600 RPM for 60 Hz AC electricity production; therefore the load from the generator is dynamically adjusted to maintain the RPM of the power turbine at 3600 RPM. Do to alterations made to the nozzle of the gas turbine to accommodate the over sizing of the gas turbine with the rest of the system the power turbine was operated at a lower RPM of 3000. This produced 50 Hz AC power from the generator.

Data-Model Comparison Approach

The Matlab/Simulink™ modules described above were integrated into a system model that could simulate the 220 kW pressurized tubular SOFC/gas turbine hybrid system of Figure 7. The system configuration was identical to that presented in Figure 8, with a fuel cell that represented to performance of an integrated SOFC/reformer module depicted in Figure 9. Experimental start-up data is presented for model verification. A series of control moves must occur during start-up in order to heat up the fuel cell, control temperatures and temperature ramp rates throughout the system, and maintain operation of the gas turbine. Two combustors were used to supply heat during start-up and SOFC stack warm-up. In the simulation results, the control moves that are identical to those recorded during the experiment were implemented in the simulation.

Dynamic Simulation Results and Comparison

The data, as stated earlier, that were acquired from the system and selected for simulation and comparison are system startup data. During this period of operation the SOFC/GT hybrid system was slowly ramped up in power to minimize the mechanical stresses from thermal shock.

Figure 11 presents the control moves made by the operator during start-up of the hybrid system. The controlled parameters were the SOFC load, recuperator and SOFC bypass and the fuel flow to the system (SOFC load not shown in Figure 11). The bypass valves were used to control the temperature of the SOFC stack. The recuperator bypass controlled the inlet temperature of the air entering the stack. The SOFC bypass was used to control the mass flow through the SOFC stack. The hybrid system utilized a dual shaft turbine. As a result the total mass flow through the system could not be controlled independent of SOFC power. With a single shaft gas turbine one can adjust turbo machinery speed (and thus compressor mass flow) by manipulation of generator load. The free-spinning turbine and compressor of the dual shaft machine thus required an SOFC bypass flow to control speed (and mass flow).

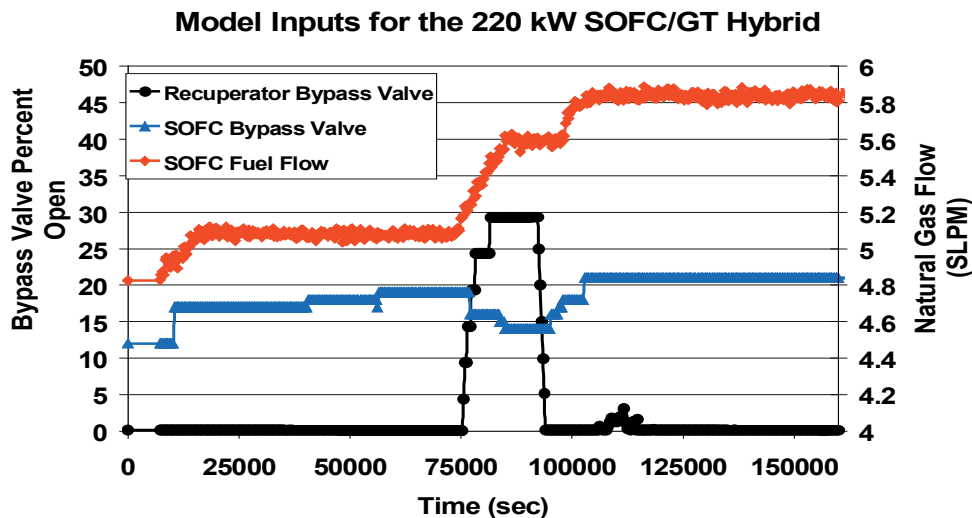

Fig. 11. Fuel flow and bypass valve positions used in the experiment and simulations

In Figure 12, the SOFC power is ramped up from 147 kW to 158 kW over a period of 100,000 seconds. The model simulation follows the SOFC power closely. The model input for the SOFC is the current demand and fuel flow rate. The cathode inlet temperature, operating fuel cell voltage, overall SOFC temperature, internal reformer temperature, combustor temperature, pressure and other operating parameters are calculated and dependent on the solution of the integrated hybrid system dynamic performance as calculated using the simulation modules described herein. Sudden drops in SOFC power were observed in the experiment as the SOFC bypass valve was opened to allow more air to bypass the SOFC. At low load (time = 10,000 seconds) the model does not capture this dynamic. However, a similar dynamic that occurs when the fuel cell is producing 157 kW (around t = 90,000 seconds) is slightly captured by the model. It is believed these sudden drops in power are due to the changes in the airflows through and around the SOFC stack. The discrepancies of the experiment and model data during changes in the SOFC bypass valve position are due to uncertainties in the exact flow dynamics and flow amounts altered by the SOFC bypass valve

Measurement data for the bypass valve position is not very accurate since the valve type used was a pneumatically actuated butterfly valve. Pressure, mass flow, and temperature deviations would lead to different mass flows being bypassed for the same valve position. Also the first degrees of movement of the valve dramatically change the amount of mass flow being bypassed. One could estimate the bypass mass flow using an enthalpy balance if accurate data for mass flow and temperatures around each bypass valves were known. Since this information was not available bypass mass flow rates were estimated by valve position only with rates averaged over a 5 minute time period.

The gas turbine performance, power output, system airflow rate and SOFC pressure are each totally dependent on the SOFC performance (in model and experiment). The power output of the gas turbine (Turbine 2 of Figure 8) is left to float depending on the SOFC stack exhaust conditions and the percentage of air that bypasses the SOFC. As more air bypasses the SOFC stack, the cooling of the SOFC stack decreases and the turbine inlet temperature (TIT) is reduced resulting in

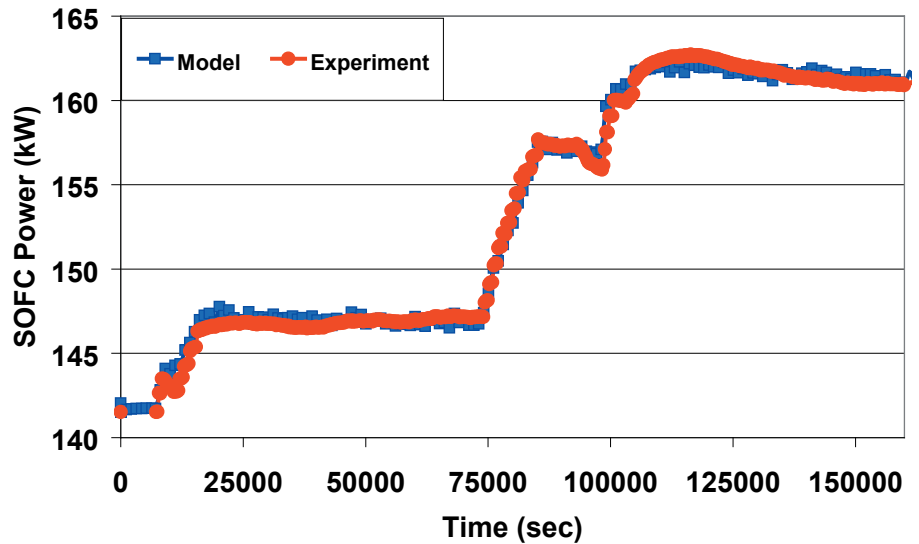

Fig. 12. SOFC power experimental and simulation comparison

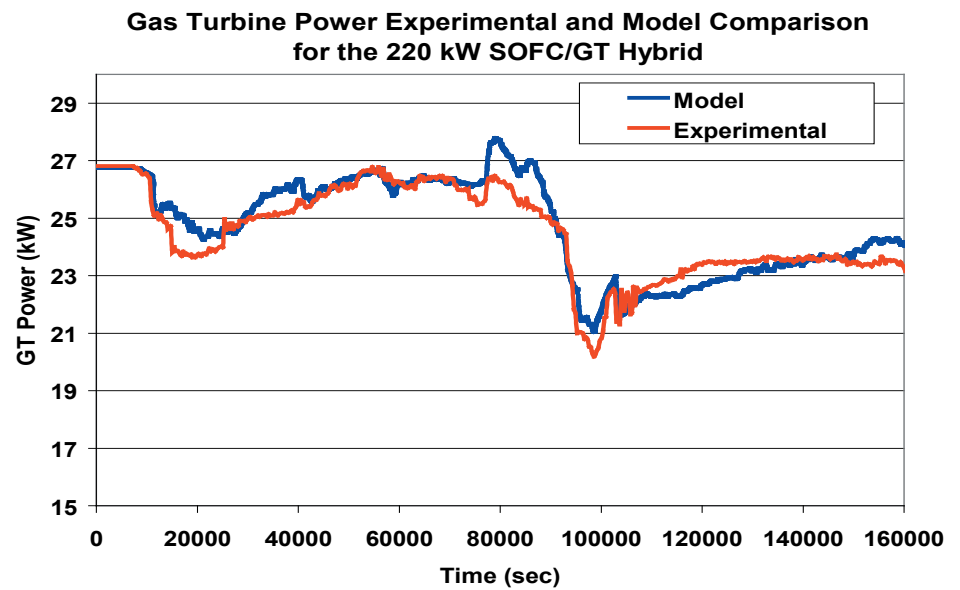

Fig. 13. Gas turbine power simulation and experimental data comparison

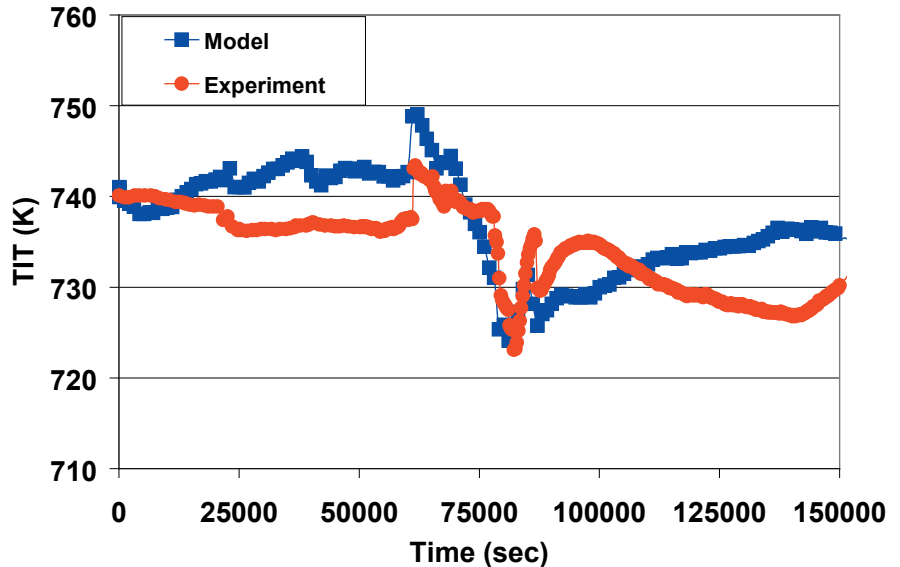

Fig. 14. Model and experiment turbine inlet temperature (TIT) comparison

1.4 Hybrid Gas Turbine Fuel Cell Systems

lower gas turbine power output. Figure 13 presents the experimental data and model results for the gas turbine power during the SOFC stack power ramp up. The model follows the power output of the gas turbine quite well with a few deviations during the SOFC stack ramp up. The model does not predict turbine power as accurately when the SOFC bypass valve is being adjusted. Some of the errors again are associated with the limited experimental data on actual bypassed mass flows.

The model well captures the change in the turbine inlet temperature (TIT) that corresponds to the SOFC ramp-up conditions as shown in Figure 14. There is a slight error in the TIT that peaks at about 6 degrees, but the overall trend is captured throughout the entire dynamic response to SOFC ramp-up perturbations. It can be seen that the change in TIT is the dominant parameter that affects gas turbine power.

Temperatures predicted by the dynamic model and observed in the experiment for several of the system states are presented in Figure 15 for the starting and end-point conditions presented in previous figures. The temperatures throughout the system are fairly close, but there are some differences. There is a 5% difference in compressor mass flow, which could cause the model to predict lower temperatures, but instead the model predicts higher temperatures. The reason the model predicts higher temperatures is due to inadequate accounting of the heat losses through out the system. The only heat losses currently considered in the system occur in combustor 1 and 2 (where there is significant heat loss). There are not any heat losses accounted for in the current SOFC and recuperator models, around which the largest temperature discrepancies are presented. Additional work is required in order to accurately quantify the heat losses associated with the SOFC stack and the recuperator. Nonetheless, the dynamic and steady state performance predictions are impressive, given the system complexities.

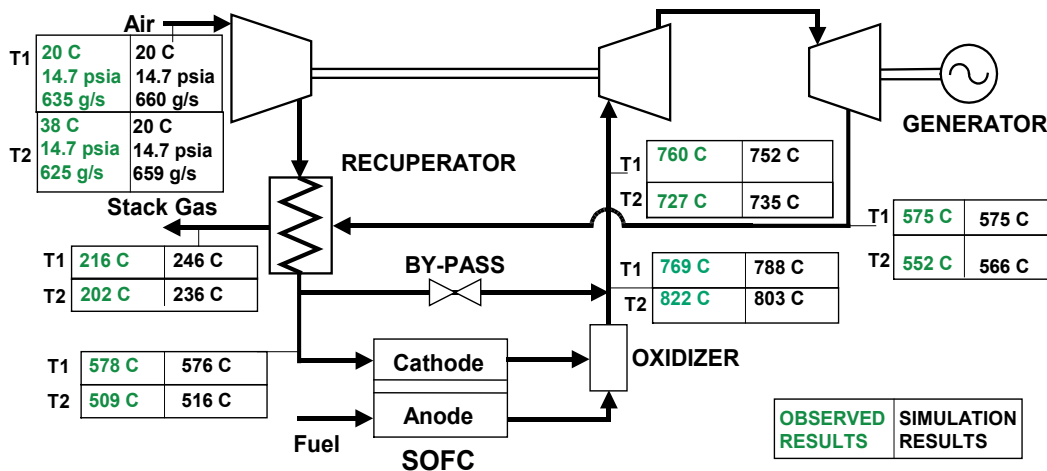

Fig. 15. Comparison of temperature states in hybrid system for initial and final conditions

Hybrid Dynamic Simulation Conclusions

A modular approach for dynamic simulation of the major system components of a hybrid FC/GT system is presented. The dynamic models were developed in a Matlab/Simulink™ environment. Using the dynamic simulation modules, a detailed hybrid system model was constructed to simulate a 220kW tubular SOFC/GT hybrid system. The dynamic model well captures the dynamic performance of the integrated experimental system for transient operating conditions observed during a system start-up. Some system dynamics are not well captured by the model especially those associated with the bypass valve dynamics, which were not adequately understood at the time of model application. Overall, the dynamic model quite accurately captures the particular set of hybrid SOFC/GT performance data during a start-up transient. This comparison shows that the model, built from first principles, can reasonably predict the dynamic performance of a complex hybrid FC/GT system. Thus verified, the dynamic model can be used to provide operational insights and guidance for design and controls development. Comparisons of system simulation results to experimental data are rare in the literature, due to the dearth of available experimental results. Although the current paper does not fully validate the current system model, it provides confidence that users can apply the dynamic models in developing control algorithms and proper procedures for start-up and shutdown of these types of complex and integrated hybrid fuel cell systems. Future investigations will be performed to further validate the systems simulation tools and test the limits of component and system dynamic responses to load demands and other possible perturbations. Being able to test these scenarios with an accurate system model provides an insightful, economical, and safe means for system research and technology advancement.

1.4-7 Hybrid System Control

Hybrid cycles comprised of high temperature fuel cells, such as the molten carbonate fuel cells (MCFC) or solid oxide fuel cells (SOFC) are very promising for generating electric power in the future, initially at the small to medium scale (250 kW to 20 MW), and later in large scale central plants (>100 MW). However, hybrid gas turbine fuel cell systems are in need of

significant advancement before they are introduced as commercial products. Some progress is needed to address the specific challenges that are introduced by coupling a fuel cell with a gas turbine given their disparate dynamic response characteristics. Thus a significant need for developing and testing control methods and strategies for hybrid gas turbine fuel cell power plants is required.

As an example, hybrid systems are sensitive to ambient conditions due the sensitivity of compressors to air density. At higher temperatures the air becomes less dense requiring a compressor to do more work to pressurize and move the air through the system. As for a hybrid system, it is challenging to maintain sufficient compressor mass flow for extreme conditions since the fuel cell is operated at a fixed temperature. If the gas turbine operates at a fixed speed there are no options for controlling the mass flow. The total power output of the system may have to be sacrificed in order to maintain appropriate fuel cell operating temperature by lowering the load demand on the fuel cell.

For the purposes of better understanding the dynamics of hybrid gas turbine fuel cell hybrid systems and for development of controls, NRCRC has developed dynamic modeling tools for FC/GT hybrid systems. In previous work²¹, transient performance and controls analyses of atmospheric hybrid systems with MCFCs were presented. Load perturbations were implemented to analyze the MCFC/GT hybrid response. In these investigations it was discovered that additional control loops are necessary to control the MCFC operating temperature. For example, varying fuel utilization across the MCFC provided some means for control but was limited. Variable speed operation of the gas turbine was tested and showed more promise, but still was limited in the particular system at lower power demands. For a larger turn-down in system power a bypass or auxiliary combustor is needed in parallel.²²

For part-load operation of a FC/GT hybrid it has been shown that a variable speed gas turbine is a required feature for both pressurized²³ and atmospheric systems.²⁴ The variable speed gas turbine provides better control of the compressor mass flow.

In the previous section a dynamic system model was described and results were compared to experimental data from the Siemens SOFC/GT system. A dual shaft turbine was used in that particular SOFC/GT system. The dual shaft turbine prevented the direct control of the compressor mass flow, which limited the operation flexibility. The system had to be operated at the maximum power safely allowed. In the current section, a 1.15 MW pressurized SOFC/GT hybrid model is developed. A diagram of the system is presented in Figure 16 and a schematic of the SOFC module is presented in Figure 17. The system was designed around the Capstone C200 micro-turbine generator. Design parameters for the C200²⁵ and the hybrid plant are presented in Table 5.

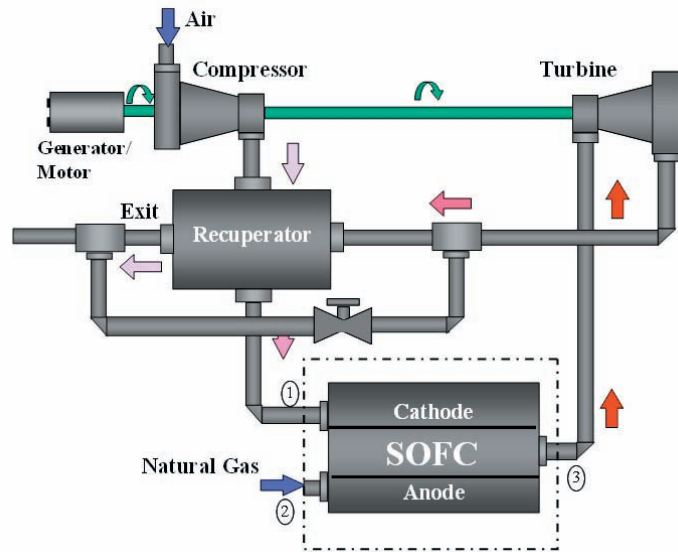

Fig. 16. Pressurized SOFC/GT hybrid cycle

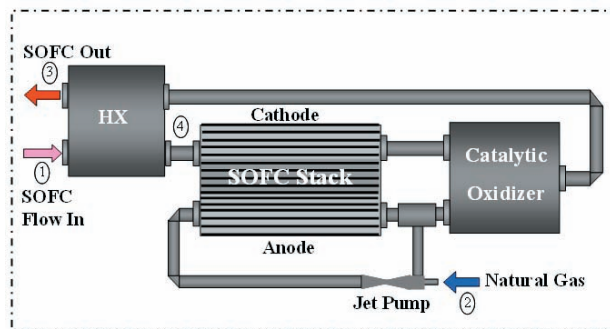

Fig. 17. SOFC module

1.4 Hybrid Gas Turbine Fuel Cell Systems

Table 5. Design parameters SOFC/GT system

Design Parameter	Value	Unit
System		
System Power	1150	kW
Combustor Efficiency	1	
Recuperator Effectiveness	1	
Heat Exchanger Effectiveness	0.4	
System Efficiency	0.73	
Gas Turbine		
Shaft Speed*	60000	RPM
Turbine Inlet Temperature*	950	C
Turbine Efficiency	1	
Mass Flow*	1.3	kg/sec
Compressor Inlet Temperature	1500.0%	C
Compressor Discharge Pressure*	43569.8%	kPa
Compressor Efficiency	75.0%	
Gas Turbine Power Mechanical Loss (Shaft)	RPM ² *8.33E-10	kW
Gas Turbine Power Electronics Efficiency	98% and 14 kW load	
Compressor Leakage	0.02	
Compressor Filter Loss	0.02	
SOFC Module		
SOFC Stack Power	960	kW
SOFC Active Area	320	m ²
Current Density	4,000	A/m ²
SOFC Operating Voltage	0.75	V
SOFC Power Electronics	100.0%	
Anode Recircuation	80.0%	
SOFC Stack Fuel Utilization	85.0%	
SOFC Average Operating Temperature	900	C

*Willis, 2005

Dynamic Model and Operating Conditions

The dynamic model used in this section is identical to that described in the previous section except that the components are arranged to simulate the cycle presented in Figure 16. The electrochemical performance for the SOFC is based on the results presented by Kim et al.²⁶

The work presented in this section is on the controller design and dynamic analysis of a SOFC/GT hybrid system. Two different cases are presented: (1) a base-load system is exposed to changing ambient temperature; (2) a load-following system is exposed to the same ambient conditions while following a load demand curve.

The design electrical power production of the SOFC/GT hybrid system is 1.15 MW. For the base-load case the system maintains 1.15 MW (1150 kW) of net electrical power production. The SOFC/GT hybrid system is operated in an extreme environment with a vast fluctuating ambient temperature. The ambient temperature is varied from -5°C to 35°C in a sinusoidal form to emulate the daily temperature fluctuation. This range of temperatures accounts for colder or frigid regions and hot regions where the system may be operated.

The system is tested in load-following mode with a varying load demand. The system is subjected to the same daily ambient conditions in all cases, while meeting a sinusoidal demand of power from 1150 kW at the peak of the day to 950 kW at the minimum power production of the day.

Controller Design

A decentralized controller design is used to control the hybrid system. The objective of the system controllers is to maintain constant power production while maintaining the SOFC operating temperature close to its design operation temperature of 900°C. Figure 18 presents the controller design. The controller design consists of a gas turbine shaft speed controller, system power controller,

and a SOFC temperature and fuel flow controller. The shaft speed controller is a cascade controller with the outer loop consisting of a feed forward and a feedback flow controller for the RPM set point. The inner loop manipulates the gas turbine power to achieve the set point provided by the outer loop. The feed forward aspect of the outer loop uses a look-up table to determine the RPM setting for a given system power. The feedback loop corrects the RPM setting for any SOFC temperature deviations. The feedback portion is very important when the compressor is operating at an off design setting. For example, extreme ambient conditions would require RPM correction.

The system power controller manipulates the SOFC current in order to meet the power demand. The gas turbine power is treated as a disturbance for this particular controller. Therefore, the SOFC power is altered continuously by manipulating the current to meet the power demand that has not been met by the gas turbine.

There is additional control of the SOFC temperature via the bypass valve located between the turbine exhaust and the recuperator. The bypass, when used, lowers the inlet temperature to the SOFC module. The fuel flow is manipulated to achieve fuel utilization of 85%. The fuel flow controller is a feed forward controller based on the current of the SOFC. The fuel utilization after one pass through the anode section is approximately 53%.

The design electrical power production of the SOFC/GT hybrid system is 1.15 MW. For the base-load case the system maintains 1.15 MW (1150 kW) of net electrical power production. The SOFC/GT hybrid system is operated in an extreme environment with a vast fluctuating ambient temperature. The temperature changes account for colder or frigid regions and hot regions where the system may be operated.

The system is tested in load-following mode with a varying load demand. The same daily ambient conditions are applied to the system while demanding a sinusoidal power profile that varies from 1150 kW at the peak of the day to 950 kW at the minimum power production time of the day.

Hybrid System Control Results

Base-Load Case

The SOFC hybrid system is simulated in base-load mode. The system is to produce its design power while operating in varying ambient conditions. As stated before the ambient temperature is varied in the range of + 20 °C. A sinusoidal temperature profile with a period of one day is used. The peak temperature is at 12 noon. Figure 19 presents the total power produced by the hybrid plant along with the SOFC and the gas turbine power. The total power produced by the hybrid plant is constant with very small deviations. The gas turbine power changes dramatically to control the shaft speed. The SOFC power changes in order to compensate for the changes in the gas turbine power.

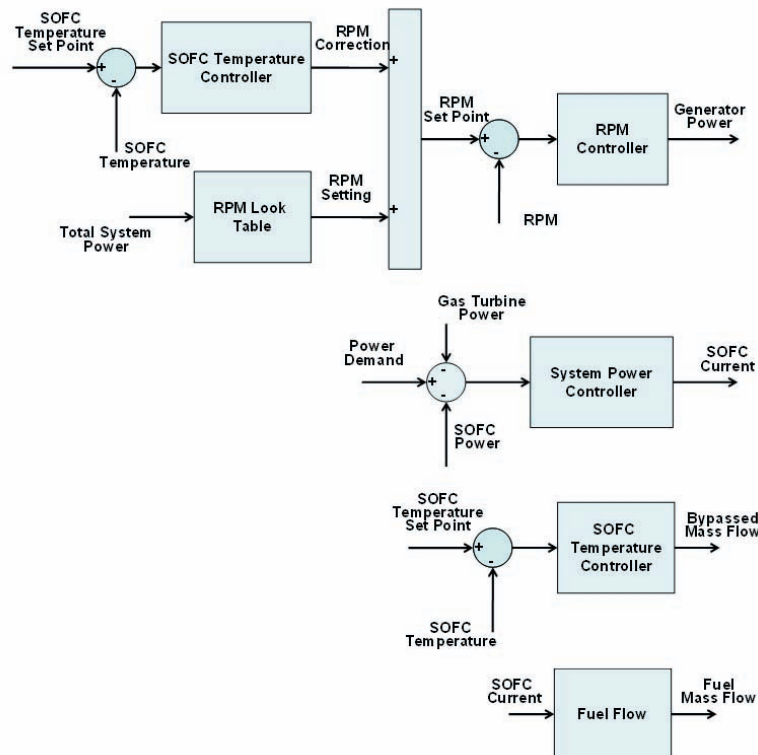

Fig. 18. Controller design

1.4 Hybrid Gas Turbine Fuel Cell Systems

The SOFC temperature is presented in Figure 20 along with ambient temperature and percent bypass mass flow. The SOFC temperature is maintained within 25 °C of the design operating temperature of 900 °C. The effects of the ambient temperature are seen when plotted with the SOFC temperature. The high ambient temperature increases the compressor outlet temperature and also decreases the compressor mass flow by reducing the air density. The reduction of the compressor mass flow can be seen in Figure 21. The dip in SOFC temperature just before 7 hours is a result of the slight increase in mass flow from the compressor presented in Figure 21 just before the mass flow sharply decreases. The mass flow from the compressor increases with the sudden increase of the shaft speed also presented in Figure 21. Two things promote this increase in shaft speed: (1) the ambient temperature is at the design inlet temperature of the compressor resulting in a more efficient compressor and (2) the TIT in Figure 22 increases providing more power to the shaft. The gas turbine power increases in Figure 19 at 6 hours to overcome this surge of net power being produced by the gas turbine. The TIT eventually lowers as the bypass valve opens and the ambient temperature continues to rise. This reduces the power produced by the turbine and thus increases the compressor work. The gas turbine power is dramatically decreased by the controllers at 7 hours, as shown in Figure 19, to allow the shaft speed to increase so that the SOFC can be provided sufficient air for cooling. Even though the gas turbine power is dramatically reduced, the shaft speed does not increase sufficiently. The extra work by the compressor prevents the shaft from speeding up and supplying more mass flow. The reduction of mass flow in the system reduces the operating pressure of the system as shown in Figure 21.

The bypass valve prevents the SOFC from overheating when the mass flow from the compressor does not fully recover. The bypass valve opens to reduce the temperature of the air entering the SOFC module. The effects of the bypass valve on the SOFC operating temperature are shown in Figure 20. The SOFC inlet temperature (state #1 of Figure 16 and Figure 17) is reduced as shown in Figure 22. This decreases the cathode inlet temperature (see state #4 of Figure 17), which helps prevent the SOFC stack from overheating. The cathode and turbine inlet temperature along with catalytic oxidizer temperature are presented in Figure 22. The SOFC operating temperature rises at around 20-21 hours. The bypass valve closed rapidly at this time triggering this sudden rise in SOFC temperature. The bypass valve partially opens again when the SOFC temperature exceeds 900°C.

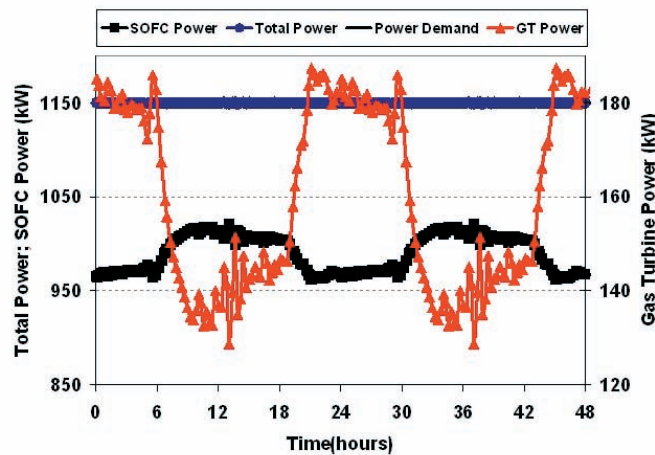

Fig. 19. Total power, SOFC power and gas turbine power produced

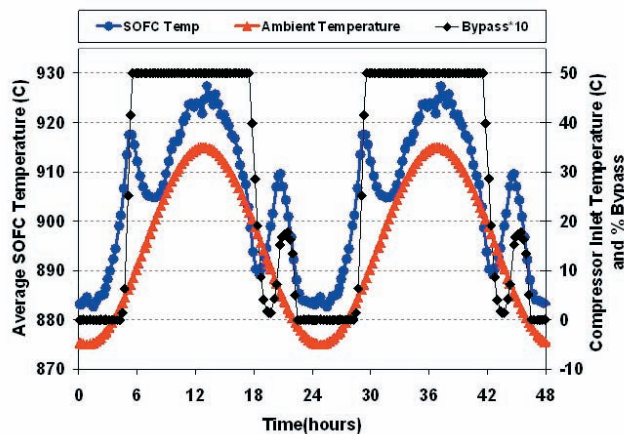

Fig. 20. SOFC average temperature, ambient temperature and bypassed mass flow

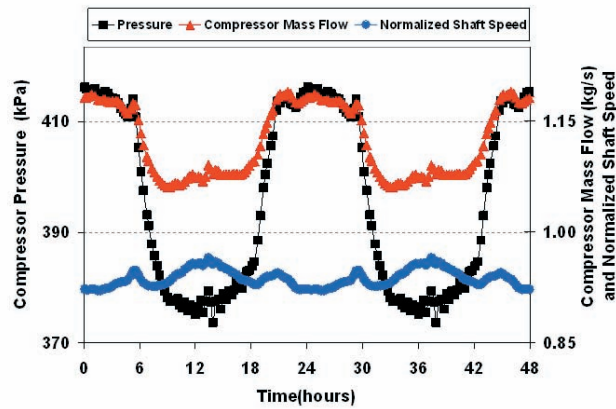

Fig. 21. Compressor mass flow, pressure and normalized shaft speed

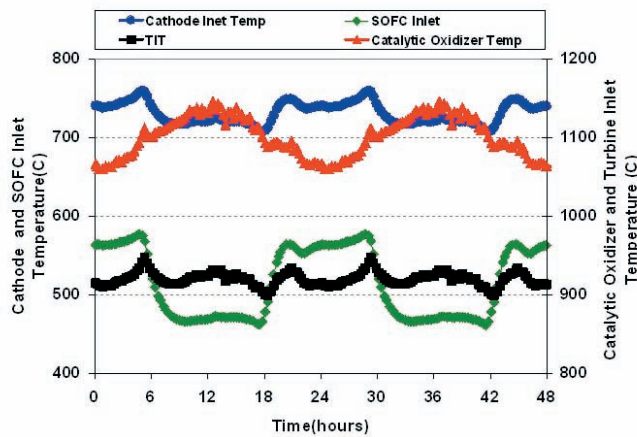

Fig. 22. SOFC, cathode, turbine inlet, and catalytic oxidizer temperatures

The system efficiency, SOFC fuel and oxygen utilization and fuel flow are presented in Figure 23. The system efficiency fluctuates between 65% and 72%. At the peak ambient temperature, the gas turbine net power is reduced to sustain sufficient mass flow from the compressor. The SOFC power is increased to offset the power drop from the gas turbine. The increased power from the SOFC increases the fuel flow which decreases the system efficiency when more fuel is required for the same net power produced by the system. The SOFC fuel utilization presented in Figure 23 is the fuel utilization after one pass through the anode section of the SOFC stack. After recirculation, the overall SOFC module electrochemical fuel utilization is 85%.

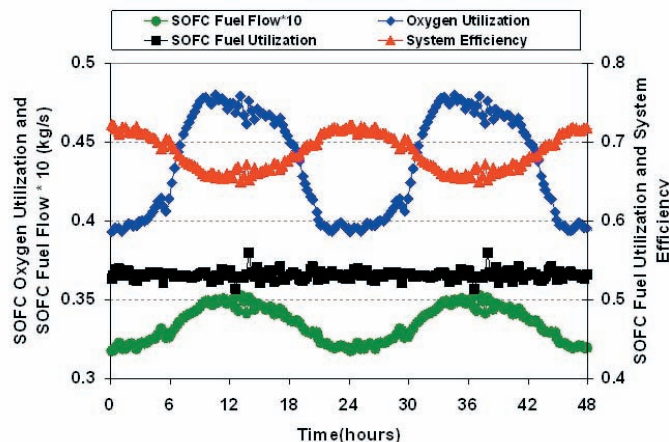

Fig. 23. System efficiency, SOFC oxygen and fuel utilization and fuel flow

1.4 Hybrid Gas Turbine Fuel Cell Systems

Load-following Case

The same ambient temperature perturbation as presented in the previous case is applied to the hybrid system in the case presented in this section. In addition, the hybrid system must follow a load demand. The load demand varies from 950 kW to 1150 kW. A sinusoidal power demand with a period of one day is used. The peak demand is at 12 noon.

The total power, SOFC power and gas turbine power are presented in Figure 24. The system was excellent in following the power demand. The fluctuations the gas turbine power can be seen in Figure 24. The gas turbine remains around 140 kW during the entire day. Unlike the case before, the gas turbine does not reach 180 kW during the colder parts of the day since the system is operating at a lower power demand at that time of day. The SOFC power has a sinusoidal profile with only fluctuations due to the gas turbine power. If the ambient temperature had not been so extreme at 12 hours, the gas turbine would have produced more net power.

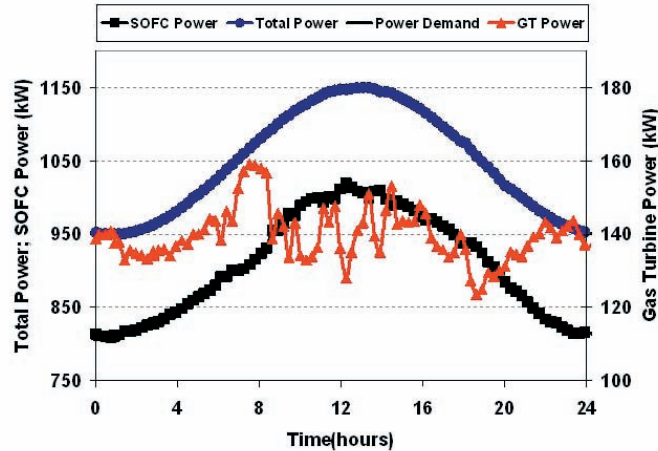

Fig. 24. Total power, SOFC power and gas turbine power produced

The SOFC temperature in Figure 25 is kept within 25°C of the design temperature as in the case presented earlier. The impact of the ambient temperature on the system can be seen in Figure 25. The same spikes and dips occur in the SOFC temperature as did in the previous case, but the logic behind them is more obvious in these results. The dip in SOFC temperature at 8 hours is a result of the sudden increase in mass flow from the compressor presented in Figure 26. The bulge at 7 hours is more apparent in this case. The mass flow from the compressor increases with the sudden increase of the shaft speed also presented in Figure 26. The same two sources as described in the previous section triggered this sudden change in shaft speed (1) more efficient compressor and (2) increase in TIT. The gas turbine power increases in Figure 24 at the same time to overcome this surge of net power being produced by the gas turbine. The TIT eventually lowers as the bypass valve opens and the ambient temperature continues to rise. This reduces the power produced by the turbine and the increases the compressor work as before. The gas turbine power is decreased by the controllers in Figure 24 to allow the shaft speed to continually increase so that the SOFC can have sufficient cooling. In this case the gas turbine power does not have to change as much since it is already at the right power range for 1150 kW system power production with 35°C ambient temperature.

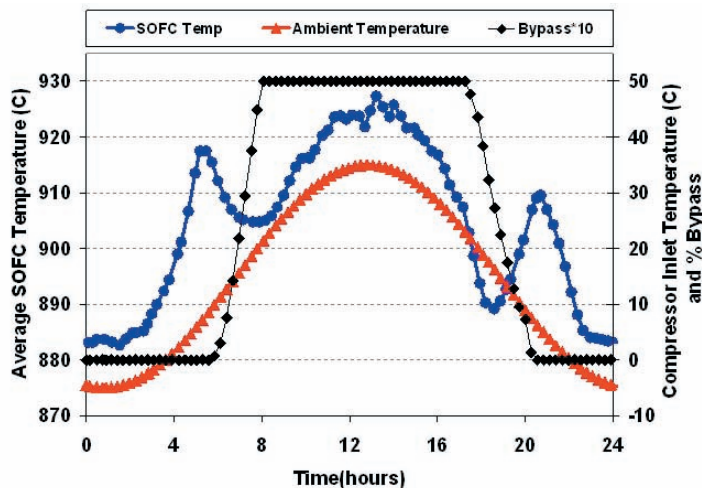

Fig.25. SOFC average temperature, ambient temperature and bypassed mass flow

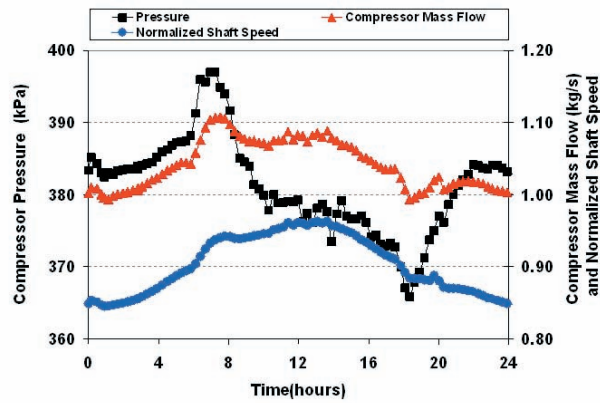

Fig. 26. Compressor mass flow, pressure and normalized shaft speed

Figure 27 presents the cathode and SOFC inlet temperature. The drop in both of these temperatures from the opening of the bypass valve can be seen between 7-17 hours. There is a more dramatic change in the SOFC inlet than the cathode inlet temperature because the heat exchanger becomes more effective due the increase in temperature differences between the SOFC inlet and catalytic oxidizer temperature. The catalytic oxidizer increase from the increase in SOFC power (more anode of gas), SOFC temperature and the reduction of mass flow (higher oxygen utilization, Figure 28). The TIT increases because of the catalytic oxidizer temperature increase, but less since the heat exchanger is more effective in transferring the heat from one flow to the other.

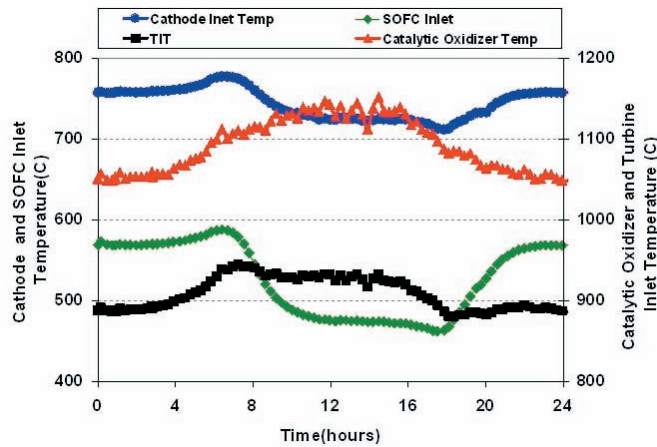

Fig. 27. SOFC, cathode, turbine inlet, and the catalytic oxidizer temperatures

The system efficiency in Figure 28 has the same profile as in the earlier case, but is higher when the power production is lower due to the higher operating voltage or more efficient operation of the SOFC. The oxygen utilization and the fuel utilization are similar to the case presented in the previous section. The oxygen utilization does reach higher levels of 47%, which indicates that the mass flow would be desired to be increased for better performance.

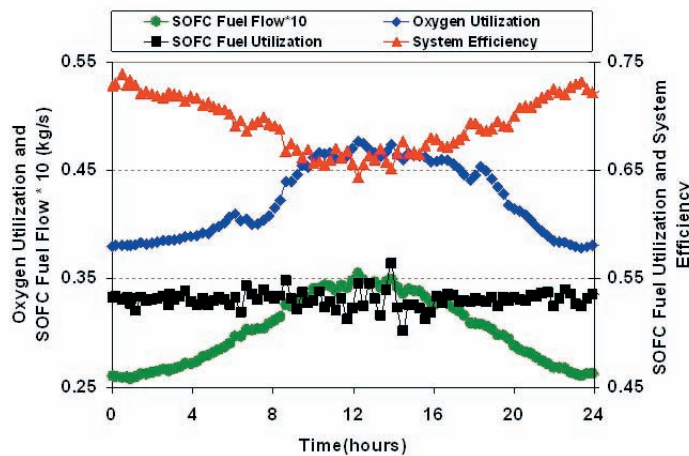

Fig. 28. System efficiency, SOFC oxygen and fuel utilization and fuel flow

1.4 Hybrid Gas Turbine Fuel Cell Systems

Summary of Hybrid System Control Study

A SOFC/GT hybrid system was developed with controllers that allow load-following capabilities. A base-load case with varying ambient temperature for two days was simulated and presented. The system maintains constant power (100% design power) while being exposed to an ambient temperature that varies significantly from -5° to $+35^{\circ}\text{C}$. The system controllers responded to changes in the ambient temperature and successfully maintained the SOFC operating temperature within 25°C of the design operating temperature. The gas turbine power had to be continuously manipulated in order to maintain the correct shaft speed and in turn the adequate amount of compressor mass flow.

A sinusoidal load profile was demanded of the hybrid system with peak power demand at 12 hours at the same time of the peak ambient temperature. The system followed the load very well. In this case, the gas turbine remained closer to 140 kW during the entire load perturbation. The oxygen utilization increased during the load perturbation.

Ideally for a SOFC/GT hybrid system, much like a gas turbine system, the oxygen and fuel utilization would remain constant over the entire range of load demand. This fixes the air-to-fuel ratio in the SOFC module. A controller that enforces constant oxygen utilization is needed to maintain consistent SOFC temperature and operation. Precisely controlling the compressor mass flow during large fluctuations in ambient temperature is challenging. If not carefully executed, the gas turbine can become unstable. The constant RPM approach with temperature error correction attempts to control the mass flow, but there are deviations in the SOFC temperature and oxygen utilization. These deviations are acceptable and the RPM control of the gas turbine provides a more stable means of controlling the system.

In future work a combination of RPM control and direct mass flow control will be investigated. This type of control approach will provide stability and accurate control of the system mass flow.

1.4-8 Research & Development Needs for Hybrid Gas Turbine Fuel Cell Systems

Over a period of more than 10 years the U.S. Department of Energy has sponsored workshops and conferences on the topic of gas turbine fuel cell hybrid systems. In many of these venues stakeholders from industry, agencies, national laboratories and universities have gathered to discuss the latest findings and results from hybrid projects and work together to identify the remaining research and development topics that should be addressed to advance hybrid systems. This section presents a summary of research and development needs for hybrid gas turbine fuel cell systems that is developed in part on the basis of input from these workshops and conferences.

System Component Design & Development

Fuel Cells

Both solid oxide fuel cells (SOFC) and molten carbonate fuel cells (MCFC) are well suited for hybrid fuel cell heat engine designs and application. General advancement of SOFC and MCFC technology will be very important to the hybrid fuel cell program. In addition, there are specific research and development needs for fuel cells that should be addressed in order to facilitate their integration with heat engines in hybrid systems. These R&D issues include:

- understanding of pressurized operation
- design for pressurized operation
 - significant pressure differentials
 - significant pressure fluctuations
- integration with oxidizers for increased thermal output to heat engine when needed
- increased fuel cell power density (ease of integration)
- nickel replacement or additive
- sulfur tolerant anode
- redox resistant anode

Research is required to enable fuel cells to meet the demands that hybrid cycles might place on them. Some of the particular needs that new fuel cell technology may need to provide to reach the expected hybrid system performance targets include the following:

- 1) Advanced materials
 - a) Increased current densities (to reduce the size and cost of fuel cells, improved materials for electrodes and electrolytes are required)
 - b) Improved mechanical properties (to withstand thermal stresses induced by successive starts and stops, and mechanical vibrations induced by turbomachinery and/or by motion in mobile applications)
- 2) Decrease air to fuel ratio (to decrease size of fuel cell itself, the equipment upstream of the fuel cell supplying the air and downstream of the fuel cell handling the exhaust gas, as well as increase the efficiency of the hybrid by being able to operate the gas turbine at a higher firing temperature)
- 3) Improved heat transfer to remove heat generated by cell
 - a) For example, use more internal reforming to absorb heat generated by cell

- 4) High speed solid state inverter technologies
 - a) New materials (semiconductor compounds and/or layered structures of different materials)
 - b) New switching techniques
- 5) Fuel flexibility
 - a) Tolerance to fuel contaminants (sulfur and chlorine compounds)

Combustors

Combustors will be required for all fuel cell systems for startup and possibly shut-down (e.g., to keep the gas turbine operating and supplying cooling air to the stack), as well as to accommodate dynamic load variations through increased heat engine output. Combustor advancement that would be valuable to a hybrid program includes those with the following possible features and/or research requirements:

- modulatable combustor (0-100% load),
- relight capability,
- can withstand constant flux of high temperature fuel cell products through inactive combustor (during steady state operation) without cooling air,
- high reliability, availability, maintainability, durability,
- low cost

Inverters and Power Electronics

Inverters and power electronics must be designed and manufactured specifically for fuel cell hybrids with the understanding that accepting input from both the heat engine and fuel cell would be preferred. The integration of the inverter and power electronics with hybrid power plants is not well understood and has not been well investigated. The following inverter component studies would be useful in a hybrid fuel cell program:

- low cost inverters
- simplified inverters
- inverter and power electronics systems analysis identifying cost, complexity, trade-offs of various inverter architectures
- inverter and power electronics systems analysis identifying cost, complexity, trade-offs of using separate inverters for fuel cell and heat engine versus a single inverter,
- integration of inverter with system
- effects of inverter and system architecture on power quality and reliability
- inverter innovation to reduce cost for lower power inverters
- inverter and power electronics robustness to match expected low maintenance of hybrid system

Sensors and Controls

New sensors and/or the application of reliable and robust sensors and diagnostics as well as well understood control algorithms and strategies based upon sensitive measurements and manipulated inputs. Research and development is required in several sensors and controls areas:

- identification and development of appropriate in-situ sensors for measurement of critical parameters
 - reformer composition
 - temperatures
 - pressures
 - flow rates (including various mixtures at high temperature and pressure)
- identification and fundamental understanding of system response to appropriate manipulated variables
- identification and understanding of controlled parameter response to manipulated variables
- high temperature (high pressure) sensors, valves, measurement and control technologies
- understanding of dynamic and steady state response to manipulated variables
- development of control strategies and methodologies based upon this understanding
- intelligent components (automatically sense failure before it occurs)

Gas Turbines or other Heat Engines

It is well known that one cannot simply replace the combustion-provided heat input to a heat engine with that available from a fuel cell and expect the heat engine to perform very well. One must, in order to take full advantage of hybrid cycles, develop and design heat engines that can both handle the flow and thermal input features that a fuel cell can provide, as well as perform well under these conditions. This requires a considerable shift in the focus of research and development for heat engine technologies. Whereas for stand-alone heat engines, increases in temperature and pressure are almost always desired to increase efficiency, application of heat engines to hybrid cycles may require movement toward designs with lower temperatures and pressures to maximize efficiency.

1.4 Hybrid Gas Turbine Fuel Cell Systems

The development of heat engines with the following general features are desired for a hybrid system:

- ability to perform well on lower quality thermal input (e.g., lower turbine inlet temperature (TIT) for the case of a gas turbine)
- ability to withstand long-duration thermal cycling (due to thermal mass of the fuel cell)
- ability to perform well with lower pressure ratios,
- larger window of operation to allow for system turndown and avoid shut-down of integrated system (e.g., movement of surge line away from typical operating conditions of a compressor – increase surge margin)
- controllability with slow time-response output of fuel cell (due to thermal mass of fuel cell)
- robust heat engines (to match maintenance cycle of fuel cell)

Research is required to enable gas turbine engines to meet the demands and features of various hybrid cycle designs. Some of the particular needs that new gas turbine technology may need to provide to reach the expected hybrid system performance targets include the following:

- 1) Recuperative cycle configurations
- 2) Advanced cycle configurations (intercooling, humid air turbine)
- 3) Combustor (capable of accepting hot vitiated air and hot depleted fuel)
- 4) Reduced emissions combustor (reduced NO_x, CO and hydrocarbons)
- 5) Catalytic combustor (capable of accepting reduced excess air, possibly approaching stoichiometric conditions)
- 6) Reduced turbine cooling penalty (advanced turbine materials including ceramics and cooling technologies)
- 7) Increased pressure ratio
- 8) Increased compressor and turbine aerodynamic efficiencies
- 9) Fuel flexibility
 - a) Tolerance to fuel contaminants (chlorine compounds and alkaline earth compounds)

Simplify/Optimize System Configuration

Several aspects of fuel cell hybrid systems could be simplified and/or optimized to advance hybrid technology, lower its cost and make it more reliable. Challenges in this general area include a fundamental understanding of fuel cell and fuel cell hybrid steady state and dynamic performance, increasing system and component RAMD, and increasing the power density of the fuel cell for better system integration.

Increase Fuel Cell Power Density or Thermal Output

- Increase power density
- Higher operating temperature fuel cells
- Increase TIT
- More stack electrical and thermal output
- Develop FCs that operated at higher & lower temperatures to facilitate FC staging

Hybrid Steady State and Dynamic Performance Optimization

- Mathematical Models for S.S./dynamic response
- System Configuration Studies
- Thermoconomics
- Subsystem consolidation

RAMD

- System failure modes & criticality affects (FMCA)
- RAMD Tests on systems and/or subsystems
- Component Tests--accelerated or otherwise
- Power electronics RAMD study

Packaging

Optimize/Customize Turbine Subsystem

The gas turbine subsystem of a gas turbine fuel cell hybrid system could be optimized or customized in many different ways to make the subsystem amenable in some cases, and more suitable in most cases to the high reliability and high efficiency characteristics that are desirable in a hybrid system. This section identifies specific advances in gas turbine technology that would be helpful to the advancement of hybrid systems. Features of hybrid-optimized gas turbine systems that need advancement in a hybrid program include:

- At least 8700 hours of continuous, maintenance-free operation
- Match the fuel cell operating and maintenance cycles (e.g., major and minor overhauls)
- Develop never-seize bearings
- Increase surge margin in design for fuel cell
- Hot section (e.g., combustor, heat exchanger) endurance (increased life)
- Develop control strategies consistent with “new” thermal input
- Develop interface requirements, and standard interface strategies
- Maximize commonality amongst hybrid components with stand alone line of gas turbines that can meet these needs
- Material selection (near term)
- Materials development (long term)
- Optimize control strategies for efficiency taking into account protection of both GT and fuel cell
- On-board intelligent diagnostics--specific sensor development
- Variable geometry compressor or turbine blades to achieve a suitable design for surge margin
- Package alternator with power electronics
- Advanced bearings--maintenance free or “on the fly” (magnetic, air, lube free)--never seize
- Control for “graceful” depressurization
- High temperature heat exchangers and recuperators
- Design GT for proper size range
- Design turbine for lower turbine inlet temperature (TIT)
- Design GT for lower pressure ratio

Analysis Tools for Combined System

Several advances are required in the areas of steady-state and dynamic modeling tools to both garner insight into the fundamental operation of systems and components, and to use for cycle optimization, design of control systems and strategies, and use for developing next generation hybrid systems. Neither steady-state nor dynamic modeling tools are readily available for simulating state-of-the-art fuel cells that are to be used in hybrid fuel cell systems. These detailed models must be developed to gain insight into both fuel cell component operation and design, as well as system and sub-system level understanding of hybrid systems. In addition, system level modeling tools must be developed that include fundamentally sound, but simplified models for fuel cells and other system components for use in developing, analyzing and optimizing system configurations as well as designing control strategies for hybrid systems. The following developments and features are to be advanced under the current hybrid systems development plan:

- Computer model for each component and system under consideration
- Validation of computer models by comparison to literature data for accurate predictions
- Acquisition of quality data from systems, subsystems and simulators for model validation
- Development and/or use of user friendly interfaces for the modeling tools to facilitate widespread use throughout the community
- Provide guidance and assist in the design of control algorithms
- Develop mechanisms for sharing empirical data previously held as proprietary
- Accurately determination of time scales of simulation required for components and entire hybrid systems
- Develop capabilities for concurrent dynamic simulation and materials / stress analyses
- Use super-computers and parallel processing to enhance computing power
- Assess existing software packages for amenability to new models and use as user interface
- Coordinate with previous efforts in related fields (e.g., Advanced Gas Turbine Systems Research (AGTSR) Program)
- Use models to identify potential control (manipulated) variables and measured outputs
- Use models to discover troublesome system or component behavior before systems are built
- Use Siemens Westinghouse Power Corporation, Southern California Edison 220 kW hybrid system, and FuelCell Energy, Capstone Turbines hybrid system as the first two data sources

Integration and Optimization of Fuel Cell/Turbine Combined Cycles

The integration and optimization of fuel cell gas turbine cycles depends upon the identification of a hybrid market and the development of system designs that address market needs. The first market that appears ripe for the use of hybrid systems is the distributed generation market. This is a logical first application for hybrid systems since the major fuel cell and gas turbine manufacturers

1.4 Hybrid Gas Turbine Fuel Cell Systems

are already developing systems and components in the size range that is applicable to distributed generation, and since natural gas fired systems are amenable to this market. In addition, hybrid systems have high efficiency and ultra-low emissions features that make them attractive in a wide variety of applications and markets. The same type of hybrid design, however, will not work in each market application. Thus, the current hybrid plan must address the issues of system integration and optimization for a variety of applications. The current plan includes supporting advances in integration and optimization to address the following:

- Service of the Distributed Generation / Industrial Market
- Service of larger central plant systems
- Service of SECA portable power , APU, and mobile applications
- Definition of appropriate system configurations for each of the above markets
- Matching of the transient response of fuel cells and turbines for each application
- Integration of fuel cell and turbine power output for each application
- Optimization of size and performance to include stored energy, fuel cell, and turbine management and control
- Understanding and control of transients over entire duty cycle, which differs for each application
- Establish criteria for installed cost, operating cost, reliability, and Life-Cycle Analysis (LCA) for each application
- Optimization of components and systems for improved performance in each application
- Perform trade-off analyses for each application
- Establish and demonstrate performance to the marketplace
- Study current operating flexibility and amenability to desired designs
- Test prototype systems, even to the point of destructive testing to investigate applicability

Research is required to enable integrated hybrid systems to meet performance expectations. Some of the particular needs that the integration technology may need to provide to reach the expected hybrid system performance targets include the following:

- 1) Systems Analysis (to identify more efficient and cost effective hybrids)
- 2) Off-design Performance Analysis (part-load and sensitivity to ambient conditions)
- 3) Dynamic and Transient Analysis (load following capability, rapid start-up and shut-down)
- 4) Fuel Processing
 - a) Compact Reformers
 - b) Membrane Reformers for Natural Gas (reactors that separate one of the products of reaction such as hydrogen or carbon dioxide as it is formed from the reaction mixture)
 - c) Resilient Reformer Catalysts for Natural Gas (less susceptible to poisons such as sulfur and chlorine compounds, and carbon deposition which will allow use of lower steam to carbon ratios)
 - d) Cost Effective Partial Oxidation Plants for “Dirty Fuels” such as coal, biomass, refinery residues (compact reactor system designs and operating at lower temperatures to increase cold gas efficiency, and reduce oxygen consumption)
 - e) Cost Effective Air Blown Catalytic Partial Oxidation and/or Reforming of Distillate for Mobile Applications such as Ships and Locomotives (compact reactor system designs and catalysts less susceptible to poisons such as sulfur and chlorine compounds, and carbon deposition which will allow use of lower steam to carbon ratios, operating at lower temperatures to increase cold gas efficiency, and reduce air usage in case of PoX)
 - f) Cost Effective Air Blown Catalytic Partial Oxidation and/or Reforming of Diesel and Gasoline for Automotive Applications (compact reactor system designs and catalysts less susceptible to poisons such as sulfur and chlorine compounds, and carbon deposition which will allow use of lower steam to carbon ratios, operating at lower temperatures to increase cold gas efficiency, and reduce air usage in case of PoX)
 - g) Cost Effective Air Blown Partial Oxidation and/or Reforming of Diesel/Gasoline Substitutes such as Alcohols and Dimethyl Ether (compact reactor system designs and catalysts less susceptible to carbon deposition which will allow use of lower steam to carbon ratios, operating at lower temperatures to increase cold gas efficiency, and reduce air usage in case of PoX)
- 5) Cost Effective and Efficient Oxygen Production (e.g., ion transport membranes)
- 6) Cost Effective and Efficient Hydrogen Separation from Syn Gas (e.g., ion/proton transport membranes)
- 7) Fuel Cleanup and Desulfurization
 - a) Regenerable Desulfurization of Natural Gas
 - b) Hot Gas Cleanup of Syn-Gas for Particulate, Sulfur and Chlorine Compounds Removal
- 8) High Temperature Heat Exchangers (transferring heat from atmospheric or low pressure fuel cell combustors to working fluid of high pressure ratio gas turbines) – next 15 years
- 9) Compact Mobile Unit Sub-system Designs (e.g., to be able to operate with unstable liquid levels caused by motion)
- 10) Hydrogen Storage

Specific Functionality and Specification of System Components

Since hybrid systems are new and evolving in both their design and the design of individual components one part of the hybrid program must focus on the specific functionality and specification of system components as they are to be applied in hybrid systems.

Market and Design Analyses

Developing an understanding of the market for fuel cell hybrid systems will be integrated into the development efforts. These efforts will endeavor to develop:

- Market understanding
- Impacts of the market(s) on HPS designs
- Sensitivity of parameters between markets and systems
- Equipment parameters and costs for each market segment
- Definition and identification of competing technologies
- Understanding of the impacts of regulatory policy
- Definitions of potential markets and market segmentation
- Interaction of systems with one another and utility grids
- Accurate models of equipment and integration (e.g., with the grid)
- Strategies for sharing of market information amongst competitive entities
- Develop steady state equipment and integrated systems analysis tools
- Develop dynamic equipment and integrated systems analysis tools
- Sources for neutral, objective and reliable information gathering and dissemination
- Collaboration amongst equipment user groups
- Collaboration amongst manufacturers
- Centers for multi-disciplinary research (Business, Economics, Engineering)

Integration of Fuel Cells and Engines

Integration of the disparate technologies that comprise a hybrid system is perhaps the most significant challenge of the hybrid program. Hybrid systems are most definitely not comprised of the simple linking of two or more technologies through an easily configurable interface. A hybrid system is an entity distinct from and superior to the sum of its parts. In this context the integration of fuel cells and engines to form an integrated whole hybrid is one of the most important tasks of the hybrid program. The goals of the integration aspects of the program include developing hybrids and hybrid concepts with:

- Competitive System Cost
- Modularity
- Operational Flexibility
- Simplicity (O&M)

It is anticipated that the integration elements of the hybrid program can be addressed in stages with the following overall staged goals:

- Adapt Existing Components (2005)
- Optimize configurations (2005-2010)
- Configure and test optimized hardware (2005-2010)
- Learn lessons from first generation optimized systems (2010)
- Develop and demonstrate next generation hybrids (2015)

Some of the research and development challenges that are faced in this integration aspect of the program include the following:

- Interface of Major Components
- Reconfiguration of Major Components
- System Operational Features
- Control
- Flow Matching
- Thermal Management
- System Balance
- Safety

Key tools and strategies that must be developed and used in the integration elements of the hybrid program include:

- Performance Modeling
- Design Systems
- Controls Research and Development
- Performance Analysis

1.4 Hybrid Gas Turbine Fuel Cell Systems

- Packaging
- Re-Engineer Hardware based upon Requirements
- Simplification of System
- Flow Modeling
- Dynamic System Modeling
- Eliminate Balance of Plant Items
- Combine Balance of Plant Items

1.4-9 Acknowledgments:

Special contributions to this work have been made by Dr. Rory A. Roberts, who accomplished most of the dynamic modeling efforts presented herein, and Mr. Yaofan Yi, who conducted most of the thermodynamic analyses.

1.4-10 Notes

1. Gottesfeld, S., and Zawadinski, T., *Advances in Electrochemical Science and Engineering*, Volume 5, Alkire, R., Gerischer, H., Kolb, D., and Tobias, C., editors, 1998.
 2. Appleby, A.J., and Yeager, E.B., *Energy*, vol. 137, p. 11, 1986.
 3. Hirschenhofer, J.H. Stauffer, D.B., Engleman, R.R. and Klett, M.G., *Fuel Cell Handbook*, Fourth Edition, DOE Contract No. DE-AC21-94MC31166, Reading, PA, 1998.
 4. Baker, B.S. "Carbonate Fuel Cells – A Decade of Progress," 191st Meeting, Electrochemical Society, May, 1997.
 5. Singhal, S.C., "Recent Progress in Tubular Solid Oxide Fuel Technology," *Proceedings of the Fifth International Symposium on Solid Oxide Fuel Cells (SOFC-V)*, The Electrochemical Society, Inc., Pennington, NJ, 1997; Minh, N.Q., "Ceramic Fuel Cells," *J. American Ceramic Society*, vol. 76, issue 3, pp. 563-588, 1993.
 6. Ibid.
 7. Dennis, R., U.S. Department of Energy, "Hybrid Fuel Cell Systems," *International Colloquium on Environmentally Preferred Advanced Generation*, 2003; Bloomfield et al., United States Patent 3,973,993; 8/10/76; Landau, United States Patent 3,976,506; 8/24/76; Bloomfield, United States Patent 3,976,507; 8/24/76;
 8. Hendriks et al., United States Patent 5,319,925; 1/14/94; Pietrogrande et al., United States Patent 5,314,761; 5/24/94; Domeracki et al., United States Patent 5,413,879; 5/9/95; Micheli et al., United States Patent 5,449,568; 9/12/95; Shingai et al., United States Patent 5,482,791; 1/9/96; Hsu et al., United States Patent 5,693,201; 12/2/97; Wolfe et al., United States Patent 5,678,647; 10/21/97; Skowronski, United States Patent 5,811,201; 9/22/98;
 9. White, D.J., *Solar Turbines Incorporated*; TTS85/492; "Energy Conversion: A Vision of the Future;" 1997.
 10. IGTI (1999). *The Hybrid Cycle: Integration of the Gas Turbine with a Fuel Cell Session*, The International Gas Turbine Institute Turbo-Expo, Indianapolis, June.
 - a) *Developmental Status of Hybrids* (1999). ASME 99-GT-400 (Abbie Layne, Mark Williams, Scott Samuelsen, Patricia Hoffman);
 - b) *Hybrid Gas Turbine and Fuel Cell Systems in Perspective Review* (1999). ASME 99-GT-419 (David White);
 - c) *Solid Oxide Fuel Cell Power System Cycles* (1999). ASME 99-GT-356 (Stephen E. Veyo, Wayne L. Lundberg);
 - d) *The Hybrid Cycle: Integration of a Fuel Cell with a Gas Turbine* (1999). ASME 99-GT-430 (John D. Leeper);
 - e) *The Hybrid Cycle: Integration of Turbomachinery with a Fuel Cell* (1999). ASME 99-GT-361 (Sy Ali, Robert R. Moritz);
 - f) *Technical Development Issues and Dynamic Modeling of Gas Turbine and Fuel Cell Hybrid Systems* (1999). ASME 99-GT-360 (Eric Liese, Randall Gemmen, Faryar Jabbari, Jacob Brouwer);
- IGTI (2000). *The Hybrid Cycle: Integration of the Gas Turbine with a Fuel Cell Session*, The International Gas Turbine Institute Turbo-Expo, Munich, May;
 - a) *Hybrid Heat Engines: The Power Generation Systems of the Future* (2002). ASME 2000-GT-0549 (Abbie Layne, Mark Williams, Scott Samuelsen, Patricia Hoffman);

- b) Tubular Solid Oxide Fuel Cell/Gas Turbine Hybrid Cycle Power Systems Status (2002). ASME 2000-GT-0550 (Stephen Veyo, Larry Shockling, Jeffrey Dederer, James Gillett, Wayne Lundberg);
 - c) A Prototype for the First Commercial Pressurized Fuel Cell System (2002). ASME 2000-GT-0551 (Sy Ali, Robert Moritz);
 - d) Ultra High Efficiency Hybrid Direct Fuel Cell/Turbine Power Plan (2002). ASME 2000-GT-0552 (Anthony J. Leo, Hossein Ghezal-Ayagh, Robert Sanderson);
 - e) Analysis Strategies for Tubular SOFC Based Hybrid Systems (2002). ASME 2000-GT-0553 (Ashok Rao, Scott Samuelsen);
 - f) Development of Dynamic Modeling Tools for Solid Oxide and Molten Carbonate Hybrid Fuel Cell Gas Turbine Systems (2002). ASME 2000-GT-0554 (Randall Gemmen, Eric Liese, Jose Rivera, Faryar Jabbari, Jacob Brouwer);
- IGTI (2001). The Hybrid Cycle: Integration of the Gas Turbine with a Fuel Cell Session, The International Gas Turbine Institute Turbo-Expo, June, New Orleans;
- a) Hybrid Fuel Cell Heat Engines: Recent Efforts (2001). ASME 2001-GT-0588 (Abbie Layne, Mark Williams, Norman Holcombe, Scott Samuelsen);
 - b) A Turbogenerator for Fuel Cell/Gas Turbine Hybrid Power Plant (2001). ASME 2001-GT-0524 Sy Ali, Robert Moritz);
 - c) A Thermodynamic Analysis of Tubular SOFC Based Hybrid Systems (2001). ASME 2001-GT-0522 (Ashok Rao, G.S. Samuelsen);
 - d) A High-Efficiency SOFC Hybrid Power System Using the Mercury 50 ATS Gas Turbine (2001). ASME 2001-GT-0521 (Wayne Lundberg, Stephen Veyo, Mark D. Moeckel);
- IGTI (2002). The Hybrid Cycle: Integration of the Gas Turbine with a Fuel Cell Session, The International Gas Turbine Institute Turbo-Expo, June, Amsterdam;
- a) The National Energy Technology Laboratory's Hybrid Power Systems Program (2002). ASME GT-2002-30668 (Richard Dennis, Mark Williams, Abbie Layne, Scott Samuelsen, Norm Holcombe);
 - b) Status of Pressurized SOFC/Gas Turbine Power System Development at Siemens Westinghouse (2002). ASME GT-2002-30670 (Stephen Veyo, Kevin Litzinger, Shailesh Vora, Wayne Lundberg);
 - c) Power Plant System Configurations for the 21st Century (2002). ASME GT-2002-30671 (Ashok Rao, Scott Samuelsen, Fred Robson, Rodney Geisbrecht);
 - d) Rao, Ashok; Samuelsen, Scott; Robson, Fred; Geisbrecht, Rodney (2002). Power Plant System Configurations for the 21st Century, ASME GT-2002-30671;
 - e) Veyo, Stephen; Litzinger, Kevin; Vora, Shailesh, and Lundberg, Wayne (2002). Status of Pressurized SOFC/Gas Turbine Power System Development at Siemens Westinghouse, ASME GT-2002-30670.
11. Rao, A. D., Samuelsen, G. S., 2002, "Analysis Strategies for Tubular Solid Oxide Fuel Cell Based Hybrid," *Journal of Engineering for Gas Turbines and Power*. 124(July 2002), pp. 503-509.
 12. Massardo, A. F., Lubelli, F., 2000, "Internal Reforming Solid Oxide Fuel Cell-Gas Turbine Combined Cycles (IRSOFC-GT): Part A- Cell Model and Cycle Thermodynamic Analysis," *Journal of Engineering for Gas Turbines and Power*. 122, pp. 27-35.
 13. Costamagna, P., et al., 2004, "Electrochemical model of the integrated planar solid oxide fuel cell (IP-SOFC)," *Chemical Engineering Journal*. 102(1), pp. 61-69.
 14. Bessette, N.F., 1994, "Modeling and Simulation for SOFC Power Systems," in *Mechanical Engineering*, Georgia Institute of Technology, Atlanta, p. 209; Yi, Y., Smith, Thomas P., Brouwer, Jacob, Rao, Ashok D., 2003, "Simulation of a 220 kW Hybrid SOFC Gas Turbine System and Data Comparison." *Journal of Power Sources*; Chan, S.H., Ho, H. K., Tian, Y., Modeling of Simple Hybrid Solid Oxide Fuel Cell and Gas Turbine Power Plant. *Journal of Power Sources*, 2002. 109: p.111-120; See Notes 11, 12, and 13.
 15. Gemmen, R. S., Liese, Eric, Rivera, Jose G., Jabbari, Faryar, and Brouwer, Jacob. 2000, "Development of Dynamic Modeling Tools for Solid Oxide and Molten Carbonate Hybrid Fuel Cell Gas Turbine Systems." 2000-GT-0552, in ASME Turbo Expo. Munich, Germany: ASME; Liese, E. A., Gemmen, Randall S., Jabbari, Faryar, Brouwer, Jacob, 1999, "Technical Development Issues and Dynamic Modeling of Gas Turbine and Fuel Cell Hybrid Systems," *Journal of Engineering for Gas Turbines and Power*; Lukas, M. D., Lee, Kwang Y., Ghezal-Ayagh, Hossein, 1999, "Development of a Stack Simulation Model for Control Study on Direct Reforming Molten Carbonate Fuel Cell power Plant," *IEEE Transactions on Energy Conversion*. PE-468-EC-0-01-1999; Lukas, M. D., Lee, Kwang Y., Ghezal-Ayagh, Hossein, 2000, "Operation and Control of Direct Reforming Fuel Cell Power Plant," *IEEE Power Engineering Society*.
 16. Ghezal-Ayagh, H., Daly, Joseph M., Wang, Zhao-Hui, *Advances in Direct Fuel Cell / Gas Turbine Power Plants*. 2003 ASME Turbo Expo, Atlanta, Georgia, 2003. GT2003-38941.
 17. Veyo, S.E., Lundberg, Wayne L., Vora, Shailesh D., Litzinger, Kevin P., *Tubular SOFC Hybrid Power System Status*. Preceedings of ASME Turbo Expo 2003, 2003. GT2003-38943; See Note 14.
 18. Roberts, R. A., Brouwer, J., Gemmen, R.S., and Liese, E.A., 2003, "Inter-Laboratory Dynamic Modeling of a Carbonate Fuel Cell for Hybrid Application." GT2003-38774, in 2003 ASME Turbo Expo, Atlanta, Georgia;

1.4 Hybrid Gas Turbine Fuel Cell Systems

- Roberts, R. A., Brouwer, J., Gemmen, R.S., and Liese, E.A., 2004, "Dynamic Simulation of Carbonate Fuel Cell-Gas Turbine Hybrid Systems." GT2004-53653, in ASME Turbo Expo. Vienna, Austria.
19. Xu, J., Froment, Gilbert F., Methane Steam Reforming, Methanation and Water-Gas Shift: I. Intrinsic Kinetics. *AICHE Journal*, 1989. 35(1): p. 88-96.
 20. Weber, A., Bastain, Sauer, Muller, Axel C., Herbstriitt, Dirk, Ivers-Tiffée, Ellen, Oxidation of H₂, CO and Methane in SOFCs with Ni/YSZ-Cermet Anodes. *Solid State Ionics*, 2002. 152-153: p. 543-550.
 21. Roberts, R. A., et al. 2005, "Development of Controls for Dynamic Operation of Carbonate Fuel Cell-Gas Turbine Hybrid Systems." GT2005-68774, in ASME Turbo Expo. Reno, NV, USA: ASME; See Note 18.
 22. Roberts, R. A., 2005, "A Dynamic Fuel Cell-Gas Turbine Hybrid Simulation Methodology to Establish Control Strategies and an Improved Balance of Plant," Ph.D. thesis, in Mechanical and Aerospace Engineering, University of California, Irvine, Irvine, p. 316.
 23. See Note 13.
 24. Roberts, R. A. and Brouwer, J., 2005, "Dynamic Simulation of a Pressurized 220 kW Solid Oxide Fuel Cell-Gas Turbine Hybrid System: Modeled Performance Compared to Measured Results," *Journal of Fuel Cell Science and Technology*, (Accepted August, 2005).
 25. Willis, J. 2005, "Capstone Microturbines." in ICEPAG. Irvine, California: APEP.
 26. Kim, J.-W., et al., 1999, "Polarization Effects in Intermediate Temperature, Anode-Supported Solid Oxide Fuel Cells," *Journal of The Electrochemical Society*. 146(1), pp. 69-78.



BIOGRAPHY

1.4 Hybrid Gas Turbine Fuel Cell Systems



Professor Jack Brouwer, Ph.D.

Associate Director
National Fuel Cell Research Center
University of California
Irvine, CA 92697-3550

email: jb@nfcrc.uci.edu

<http://www.nfcrc.uci.edu>

Dr. Jack Brouwer is Adjunct Assistant Professor of Mechanical and Aerospace Engineering at U.C. Irvine (UCI) and the Associate Director of the National Fuel Cell Research Center (NFCRC). Dr. Brouwer completed doctoral studies in Mechanical Engineering and Chemical Engineering at the Massachusetts Institute of Technology (MIT). Prior to joining the NFCRC, Dr. Brouwer was a research faculty at the University of Utah, a Senior Engineer at Reaction Engineering International, and a Staff Scientist at Sandia National Laboratories. Dr. Brouwer has expertise in energy systems, fuel cell technology, turbulent reacting flows, computational fluid dynamics, chemical kinetics, and electrochemical reactions with concurrent heat, mass and momentum transfer in electrochemical systems. Dr. Brouwer is leading research and development efforts including projects on hydrogen refueling, the world's first independent fuel cell vehicle testing, the world's first testing and evaluation of a hybrid fuel cell gas turbine system, the development and application of dynamic fuel cell and hybrid fuel cell systems simulations, and the advancement of reformation technologies for gaseous, liquid, and solid hydrocarbon fuels. Dr. Brouwer is a regular instructor at UCI in the areas of fuel cells, thermodynamics, heat transfer, and combustion. He developed and introduced the first graduate level fuel cell course to UCI in 2002, and is a regular instructor in fuel cell short courses around the world.