

UC Irvine

UC Irvine Previously Published Works

Title

Experiments on the injection, confinement, and ejection of electron clouds in a magnetic mirror

Permalink

<https://escholarship.org/uc/item/3jp372br>

Journal

Physics of Fluids, 21(10)

ISSN

00319171

Authors

Eckhouse, S.
Fisher, A.
Rostoker, N.

Publication Date

1978

DOI

10.1063/1.862101

Peer reviewed

Experiments on the injection, confinement, and ejection of electron clouds in a magnetic mirror

S. Eckhouse, A. Fisher, and N. Rostoker

Department of Physics, University of California, Irvine, California 92717
(Received 11 October 1977; final manuscript received 27 March 1978)

A cloud of (5 to 10 keV) electrons is injected into a magnetic mirror field. The magnetic field rises in 40–120 μ sec to a maximum of 10 kG. Two methods of injection were tried: In the first, the injector is located at the mirror midplane and electrons are injected perpendicular to the magnetic field lines. In the second scheme, the injector is located near the mirror maximum. Up to about 10^{11} electrons were trapped in both schemes with a mean kinetic energy of 0.3 MeV. Measured confinement time is limited only by the magnetic field decay time. The compressed electron cloud executes electrostatic oscillations. The frequency of the oscillation is proportional to the number of electrons trapped, and it is independent of the value of the magnetic field and the initial electron energy. The electron cloud was ejected along the mirror axis and properties of the ejected electron cloud were measured by x-ray pulses from bremsstrahlung of electrons on the vacuum system wall and by collecting electrons on a Faraday cup.

I. INTRODUCTION

In the last twenty years, unneutralized electron plasmas have been proposed for creating strong electrostatic fields that can be used for ion acceleration.^{1–3} The development of strong relativistic electron beams have made possible the creation of nonneutral electron plasmas with large self-electrostatic fields of the order of 100 MV/m which increased the need for understanding nonneutral plasma.

A plasma with higher electron densities than ion densities over macroscopic ranges must create an electrostatic field which will blow the plasma apart, and an equilibrium can exist only if a restoring force is applied which can, for example, be a magnetic field. Possible equilibria of nonneutral magnetically confined plasmas which were studied theoretically and experimentally are: the rigid rotor equilibrium in an infinitely long cylindrical plasma column confined radially in a solenoidal magnetic field,⁴ an electron plasma confined in a toroidal magnetic field,^{5–7} and a nonneutral plasma confined in a magnetic mirror^{8–10} which is the subject of this paper.

The main difference between mirror confinement and toroidal or cylindrical confinement lies in the fact that the finite length of the electron cloud creates an electrostatic field component along the mirror axis (z) and the mirror action of the magnetic field creates the restoring force in the z direction.

A possible equilibrium of an electron cloud in a magnetic mirror was investigated by Davidson *et al.*¹¹ They calculated an equilibrium configuration of a cloud of electrons with no spread in total energy H_0 and canonical angular momentum P_θ . The calculation is to first order in $|e\phi/H_0|$, where ϕ is the electrical potential. The cloud in their calculation turns out to be hollow.

An experimental study of nonneutral electron clouds in a magnetic mirror was done by Kapetanakis *et al.*⁸ With fields of about 30 kG at the mirror midplane they have been able to compress and accelerate up to 10^{11} electrons, which were held in equilibrium for times of

the order of 10 msec. Equilibria in toroidal geometries were studied by Daugherty *et al.*,⁵ Clark *et al.*,⁶ and Mohri *et al.*⁷ In these experiments the magnetic field served mainly to confine the electron cloud and not for compression and acceleration. In the first two experiments, electron densities of up to 10^{10} electrons cm^{-3} were achieved, and Clark *et al.*⁶ measured, directly, electrostatic potentials of up to 300 kV.

Recently,¹² it has been suggested that an electron cloud confined in a periodically varying toroidal magnetic field could be used to confine heavy ions which would be inductively accelerated. The electrons will not be accelerated because of their higher magnetic moment which reflects them in the local mirrors. Calculations show that such a device¹² may accelerate 10^{14} ions to the 10^9 eV energy range. Many of the results of injection studies and stability properties reported in this work are relevant to this accelerator concept.

Section II of this work describes the details of the experimental systems used. In Sec. III we describe some results of injection studies with the electron injector located at the mirror midplane and near mirror maximum. Section IV deals with the equilibrium properties of the cloud and with our ejection experiments.

II. DESCRIPTION OF THE EXPERIMENT

A schematic view of the magnetic coil system and the vacuum system is given in Fig. 1. The mirror magnetic field is achieved by using a set of independent coils with an internal diameter of 12.5 cm. Usually, three coils are used for the mirror and one coil for ejection. The use of individual coils facilitated variation of the field configuration. The field configuration used in most experiments is an asymmetrical mirror configuration, and the dependence of B_z on z for this configuration is also given in Fig. 1. For this configuration the field has a mirror ratio of 1.35 on the lower side and 1.87 on the higher side, and the distance between the field maxima is 20 cm although the effective length available for confinement is only 10 cm because of the unequal mirror ratios. With this configuration,

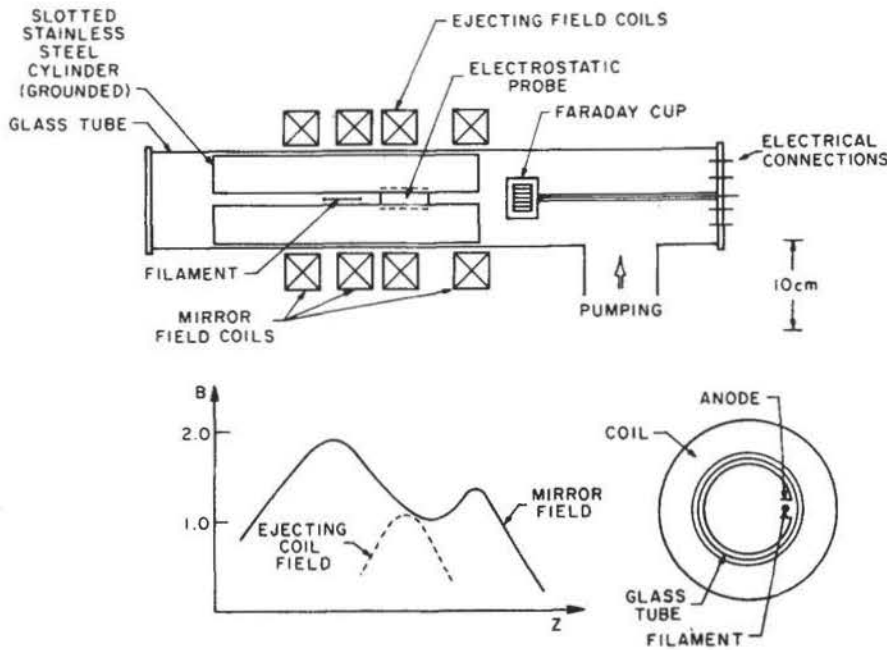

FIG. 1. Experimental apparatus.

a field strength of 12 kG can be achieved at the mid-plane with a 12 kJ capacitor bank. The mirror field risetime can be varied in the range of 40 to 160 μsec by using different connections of the capacitor bank to the coils. The field decays exponentially with a time constant of 1.6 msec in the long risetime case and of 0.25 msec in the short risetime case. A coil identical to the coils used for the mirror is used as an ejecting coil; it creates a field that rises at a rate of up to 0.36 kG/ μsec and to a maximum of 18 kG at the coil center.

Because of the fast risetime of the magnetic field, a metal vacuum system could not be used in the experiment. Instead, we used a Lucite system in some of the early experiments and a glass system in most cases. With the Lucite system, pressures of about 10^{-6} Torr could be achieved and the lifetime of the cloud was very limited. With the glass system, the usual working pressure was 5×10^{-8} Torr which extended the lifetime of the cloud to practically the decay time of the magnetic field. In both cases the vacuum system has an 11.5 cm i.d. In this cylindrical tube is a slotted, grounded stainless steel tube with an internal diameter of 10 cm. Stainless steel screens with the same dimensions were also used in some cases.

The injector is located at the slot of the metal cylinder

and is shown schematically in Fig. 2. The injector was described in detail earlier.⁹ The injection voltage was varied in the range of 4 to 15 kV and injection currents of up to 20 A were achieved with pulses of up to 10 μsec . The injector was located at different axial locations along the mirror as will be described later. The injector was built in such a way that the filament and the anode plate were parallel to the mirror axis. The filament extended 1 cm into the metal cylinder so that it was 4 cm from the mirror axis. In some cases two injectors at opposite radial positions on the metal cylinder were used, but this had no apparent influence on the results.

The polarity of the injector was always such that the $\mathbf{E} \times \mathbf{B}$ direction at the injector was directed into the center. An opposite electric field direction resulted in shorts at the injector. The injector voltage pulse could be operated at different times relative to the start of the magnetic field.

The diagnostic of the system included x-ray detectors, an electrostatic probe, a microwave detector, and a Faraday cup. Two x-ray detectors were used: a 5 cm \times 5 cm NaI(Tl) detector with a 5 cm diam photomultiplier 10 dynode tube was used mainly to estimate the electron energies. The detector was calibrated by a

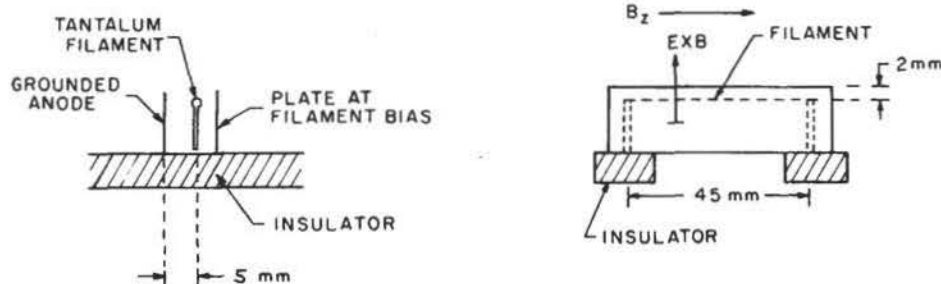

FIG. 2. Thermionic electron injector.

Co^{60} source and was then exposed to the x-rays from the experiment. The detector signal was integrated with a 25 μsec time constant which is long enough to identify the charge and the energy left by the photon in the detector. The detector was placed at a distance from the experiment such that the rate was about 10 photons per msec, which permitted energy measurements without pile up. In the energy range considered, most of the interactions are under the photopeak so that the method measures the photon energies. A second detector was a 7.5 cm \times 7.5 cm NE102 plastic scintillator attached to a 5 cm ten dynode photomultiplier. This detector was used in the ejected x-ray pulse measurements because of its better time response.

An electrostatic probe⁸ measuring induced currents was used to detect electrostatic oscillations of the electron cloud. The electrostatic probe was located at the mirror midplane in the metal slot at the same radius as the metal cylinder. It is 1.9 cm wide and 4.5 cm long. The signal is fed to an oscilloscope through a 50 Ω terminated line.

A Faraday cup was used to detect the total charge in the cloud. The Faraday cup consists of a 5 cm diam copper cup; the front face is covered with a copper screen. The collector is made out of metallic hexagonal tubes 2 mm wide and 2 cm long which are packed in a honeycomb structure and attached to a metal base. The axis of each tube is parallel to the axis of the experiment. This structure reduces the effect of secondary electrons, since a secondary electron emitted has a high probability of being re-absorbed in the collector and not contribute to the net charge. The collector has a radius of 2 cm. The Faraday cup is located on the side of the weak mirror at a distance of 12 cm from the mirror minimum (Fig. 1). The field value at the Faraday cup location is 0.4 of the lower mirror maximum. The Faraday cup signal is fed through a 50 Ω terminated coaxial line.

A microwave horn is located 40 cm from the mirror midplane on the field axis. The horn is connected to a 5 m long x-band waveguide which feeds the signal into an x-band detector (8 to 12 GHz) located in the screen room.

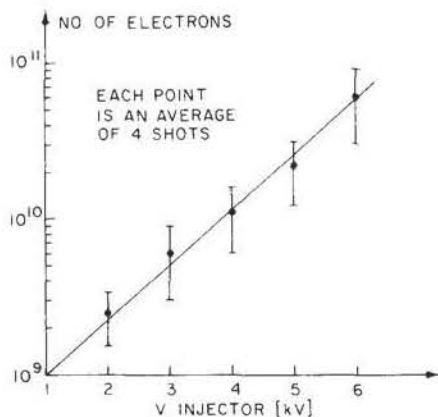

FIG. 3. Number of trapped electrons as function of injector energy.

III. RESULTS OF INJECTION STUDIES

Injection of an electron cloud into a toroidal field is most simply achieved if the injector is located on the boundary of the torus. This concept was used successfully by Daugherty *et al.*⁵ We tried to use the same injection concept in a mirror experiment.⁹ This is in contrast to the Maryland experiment in which the injector was located out of the mirror and electrons were injected along a bias magnetic field. The advantages of cross-field injection at the mirror midplane are: First, the electrons are injected at the location in which they are expected to be trapped and most of their energy should be in the perpendicular direction, which should make their trapping easier. Second, no magnetic guide field is needed. The basic disadvantage of locating the injector at the midplane is that one expects a thermionic injector to emit neutrals which might neutralize the electron cloud. As has been shown¹³ and as we shall show, one can overcome this difficulty by some simple cleaning procedures.

In the injection studies made by Daugherty *et al.*⁵ they found that the amount of injected charge increased with the injection voltage. They explained this by the fact that an electron has to meet some energy requirements in order to be injected into the existing potential well created by previously trapped electrons. A very similar dependence was observed by Clark *et al.*⁶ Figure 3 shows the number of trapped electrons as a function of the injector voltage for the injector located at the mirror midplane. The number of electrons trapped in each shot was measured by ejecting them on the Faraday cup and measuring the resulting charge. The large error bars in Fig. 3 correspond to large changes from shot-to-shot in the number of trapped electrons when this injection method is used. We must emphasize that, since the flow in the injector was close to space-charge limited in these experiments, the filament current also changes as a function of voltage.

However, the more important dependence of the injected charge is the dependence upon filament current. For our experimental conditions, successful injection is possible only if the current is higher than a critical current of about 5 A. (By successful injection we mean one at which at least 10⁹ electrons were trapped.) This indicates that some kind of collective effect is related to a successful injection.

During the injection we also measure the microwave power emitted in the x-band. We found that all successful injections were accompanied by a microwave pulse. Figure 4 shows two typical traces of microwave power measured during injection. The microwave pulse always lasts for 1 to 2 μsec . In the lower trace the pulse appears 9 μsec after the magnetic field start while for the higher current it appears only 6 μsec after the field start. The value of the magnetic field is, of course, higher for the longer delay. Figure 5 is a plot of the dependence of the value of the magnetic field (measured in units of the electron cyclotron frequency Ω_e) at which microwave emission in the x-band appears as a function of filament current. This is done for a large variety of

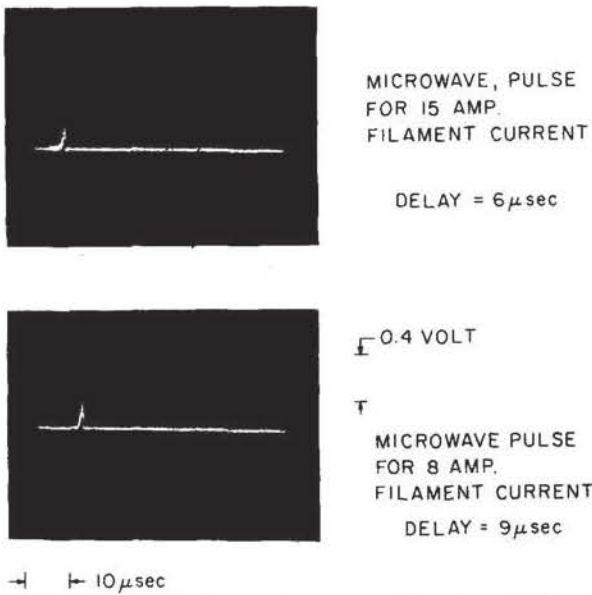

FIG. 4. Typical x-band microwave pulses for midplane injection for two different injector currents.

experimental conditions as indicated in the figure. The value of the plasma frequency ω_p (this can be estimated from the measured filament emission current) for the electron density near the filament is of the same order as the electron cyclotron frequency Ω_c . However, ω_p is higher for higher currents so that if the conditions for microwave emission would have been $\omega_p = \Omega_c$, then Ω_c would have been an increasing function of the filament current in contrast to the experimental results.

In addition to the microwave power measured during injection, a strong noise is also apparent on the filament current trace at the time of microwave emission. This is very similar to the observations of Daugherty *et al.*⁵ The time of microwave emission is approximately the time for Hull¹⁴ cutoff conditions. It must also be pointed out that the microwave power measured fits an electric field at the injector of the same order of magnitude as the injector external electric field. It is therefore possible that the microwave field created plays an important role in the electron injection.

We have also tried to pulse the injector at different times relative to the magnetic field. Because of the wide pulse we used, the behavior is not very clear. However, no successful injection was achieved whenever we pulsed the injector at late times such that the magnetic field value was higher than the one appearing in Fig. 5 for the appropriate current.

A second injection method we used was one in which the same injector used previously was located at the same radial point but near the high mirror maximum (this is the location appearing in Fig. 1). All shots done with this method were done with 160 μ sec rise time of the mirror field. This method is similar to the one used by Kapetanakis *et al.*,⁸ the main difference being that the injector is still located inside the mirror and no bias magnetic field is used.

The maximum number of electrons trapped by this

method is similar to the numbers achieved in the previous method. Up to about 5×10^{10} electrons were trapped with an injector voltage of 10 kV, current of 10 A which decays to zero after 10 μ sec when the injector pulse starts together with the magnetic field. When the injector pulse was delayed for more than 5 μ sec relative to the start of the magnetic field, no detectable injection occurred. So, injection occurs only if the magnetic field of the injector is lower than 0.4 kG. This value is consistent with the value reported by Kapetanakis *et al.*⁸ who reported trapping for delays of up to about 20 μ sec of the injector pulse that under their conditions corresponds to a field of about 0.3 kG at the mirror midplane. No critical current was observed in this case. No microwave emission in the x-band was detected either. This injection method can therefore be explained on a single particle behavior basis where the trapped electrons are those electrons which have the right momentum to be trapped in the mirror.⁸

Both methods have a similar and poor trapping efficiency of 10^{-3} to 10^{-4} , which is defined as the ratio between the number of electrons trapped to the number of electrons emitted by the filament.

IV. EQUILIBRIUM PROPERTIES OF THE ELECTRON CLOUD AND EJECTION OUT OF THE MIRROR

A. Holding power of a magnetic mirror and electron ejection

A nonneutralized electron cloud is accompanied by an electrostatic field. An axially symmetric electron distribution has electrostatic field components in the radial direction (E_r) and the axial direction (E_z). The radial component of the electrostatic field is balanced by the magnetic field while the axial component can be balanced by the mirror action of the magnetic field. This is, of course, true when one neglects the self-magnetic field of the cloud.

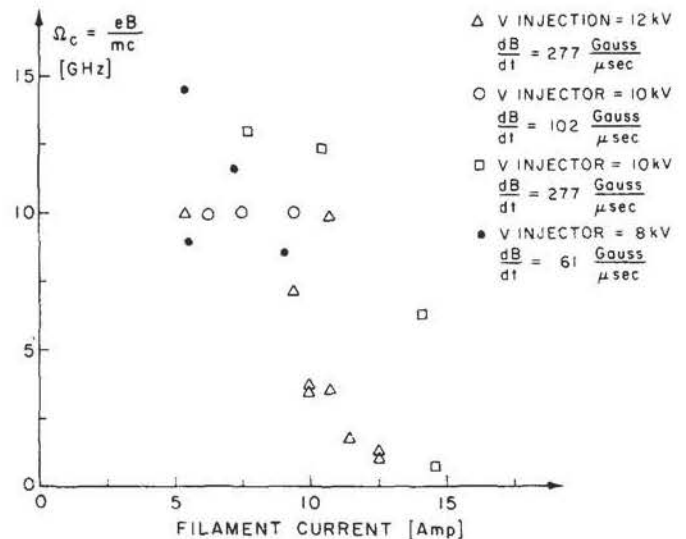

FIG. 5. Value of magnetic field at the injector at which microwave pulse is detected as function of electron current leaving filament. Magnetic field is shown in units of the electron cyclotron frequency.

Calculation of an electron cloud equilibrium in a magnetic mirror was done by Davidson *et al.*¹¹ They have done an analytic calculation which shows, approximately, that an equilibrium is possible for a cold electron cloud in a magnetic mirror provided that the number of electrons is small enough so that their self-electrostatic field can be neglected. It is clear, therefore, that such a calculation cannot give the number of electrons that can be trapped in a given mirror. However, a very rough calculation that gives the scaling laws can be done very easily. If the electron has a magnetic moment $\mu = mv_{\perp}^2/2B(r, z)$, where v_{\perp} is the perpendicular electron velocity, m is the electron mass, $B(r, z)$ is the magnetic field as a function of the radius r and axial position z , then the electron will be trapped if the condition

$$e |E_z(r, z)| < \mu \left| \frac{\partial B}{\partial z} \right|$$

exists for every electron in the mirror where $E_z(r, z)$ is the z component of the electric field at a point (r, z) . This assumes, that the electron can be treated adiabatically. Now suppose that N electrons are trapped in a mirror of length L with a mirror ratio M ; we then have

$$|eE_z| \sim \frac{Ne^2}{(L/2)^2} = \frac{4Ne^2}{L^2},$$

$$\left| \mu \frac{\partial B}{\partial z} \right| \sim \frac{W_{\perp}}{B} \frac{B(M-1)}{L/2} = \frac{2W_{\perp}(M-1)}{L},$$

where W_{\perp} is the perpendicular electron kinetic energy.

For the equilibrium to be possible, we demand

$$2W_{\perp}(M-1)/L > 4Ne^2/L^2,$$

or

$$N < LW_{\perp}(M-1)/2e^2.$$

For our experiment we have: $M = 1.35$, $L = 10$ cm, and $W_{\perp} = 0.3$ MeV and we get

$$N < 4 \times 10^{12}.$$

This value is more than an order of magnitude higher than the number of electrons trapped. We use this dependence of the number of possibly trapped electrons on the mirror ratio in order to eject the cloud at a certain moment by increasing the field at the mirror midplane until the mirror ratio of the weak mirror decreased to 1. In this way we can push the electron cloud out of the mirror, measure the charge directly on a Faraday cup, and measure the x-ray flux associated with bremsstrahlung of electrons hitting the walls of the vacuum chamber.

Figure 6 is a typical example of two x-ray pulses resulting from ejection of the electron clouds. In the upper part of the figure is given the time dependence of the mirror ratio. What is seen quite clearly from the figure is that for the upper trace which shows a larger number of electrons in the cloud (assuming equal electron energy distribution in the two shots), ejection starts earlier than for the lower trace which shows a smaller number of electrons. Both shots were made with the same voltage on the injector and the same maximum magnetic field, but with different injector cur-

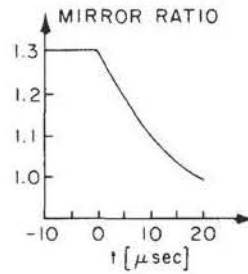

FIG. 6. Two ejection events as recorded on a 7.5 cm \times 7.5 cm NE102 x-ray detector. Upper graph—mirror ratio as a function of time. Two lower traces are x-ray pulses recorded on the same time scale as the upper graph. Ejection starts earlier for a cloud with more trapped electrons.

rents, so that one can expect similar electron energies in both cases. We assume, therefore, that the current in the x-ray detector is proportional to the rate of electron ejection and the area of the pulse is proportional to the number of electrons that were trapped in the cloud. The x-ray flux was measured in both cases by the 7.5 \times 7.5 cm NE102 scintillator which was located 100 cm from the source.

B. Equilibrium properties of the cloud

1. Electron energy

The use of the NaI detector enables us to estimate the energies of electrons in the cloud.⁹ This cannot be done during the ejection of electrons since in this case there is a pile up of pulses in the NaI detector which permits no spectroscopic measurement. However, the energy can be estimated by using the fact that because of residual gas in the system, electrons are scattered to the walls and emit bremsstrahlung photons.

When the emission rate was low enough, we could measure the amplitude of the integrated pulses in the NaI detector from which we estimate the electron energy. For an injection voltage of 10 kV, with the injector located at the field minimum and a maximum field of 9 kG at the midplane, the average energy measured is 0.3 MeV. In these shots the voltage pulse was applied to the filament at the same time as the magnetic field

is fired. The injector pulse lasts for $10 \mu\text{sec}$ which corresponds to magnetic field values at the injector of 0 to 0.6 kG, so that a measured energy of 0.3 MeV is consistent (assuming adiabatic compression) with a magnetic field at the injector of 0.3 kG which is within the limit given here. A similar value of kinetic energy of the electrons is measured when the injector is located near the mirror maximum and for the same injector voltage. No measurement of the energy spectrum and its dependence upon the experimental parameters has been attempted because of the very limited accuracy of this method.

2. Lifetime of the electron cloud

If no apparent instability exists, it seems reasonable to expect that in a perfect vacuum the electron cloud should exist as long as the magnetic confining field exists.⁸ However, if a residual gas exists in the system, then collisions of electrons with neutrals should scatter them out of the portion of phase space which is trapped.

The problem becomes crucial for the case of an injector located between the mirrors. In this case even for a very low residual pressure before the experiment is started, there is a good chance that the neutral density will grow because of direct emission by the filament and because of emission from the walls which are hit by electrons not trapped.

As mentioned in Sec. II, part of the early shots with the system were done with a Lucite vacuum container. As demonstrated previously by Fisher⁹ successful injection and compression of an electron cloud in a magnetic mirror are also possible under poor vacuum conditions if the risetime of the compressing field is short enough ($50 \mu\text{sec}$). In the first stages of the experiment therefore, we tried to use a Lucite tube as the vacuum container.

The results of lifetime measurements for the Lucite system are shown in Fig. 7. This figure shows the flux of x-rays measured by the $7.5 \times 7.5 \text{ cm}$ NE102 detector located 50 cm from the experiment in these shots. What is seen on the traces is that x-ray emission starts even before compression has been completed at about $100 \mu\text{sec}$. On the other hand, the x-ray pulse detected after the ejecting field has been fired diminishes to practically zero for a delay of 0.5 msec. The upper traces in each picture are traces of the current in the mirror and ejecting field coils. (The jumps on the current traces during crowbaring are instrumental; however, the rise of the mirror field and ejecting field are clear). So, we conclude that an electron cloud can be trapped in a magnetic mirror field even with poor vacuum conditions, but the lifetime of the cloud is limited, and the cloud is neutralized at an early stage of the experiment.

The situation with the glass system is completely different. The residual pressure in the system measured when the filament is heated to the operating temperature is in the range 5×10^{-8} to 10^{-7} Torr. Another step

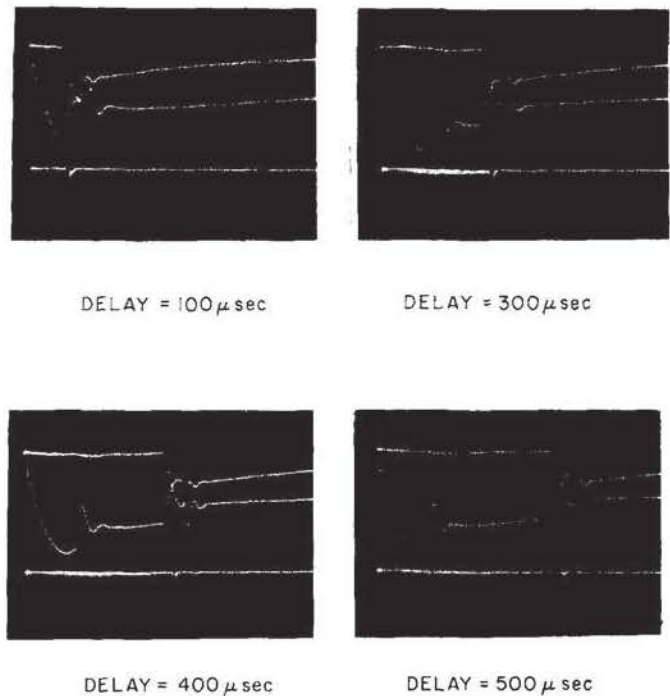

FIG. 7. Ejection of the cloud in the Lucite system for different delays after magnetic mirror field start. Upper two traces in all figures show the time dependence of the mirror field and ejecting field. The pulsed form on the magnetic field traces during the capacitor band crowbar is instrumental. Lower trace on all figures are x-ray flux measured with $7.5 \text{ cm} \times 7.5 \text{ cm}$ NE102 detector. Horizontal scale is $100 \mu\text{sec}/\text{div}$ on all traces. X-ray pulses start appearing continuously approximately $100 \mu\text{sec}$ after injection.

we use to clean the system before each shot is to operate the injector continuously with a voltage of 500 V and a current of 100 mA for about 100 sec before each shot. When the injector is operated under these conditions, one bombards the injector plates and the vacuum system wall with electrons and reduces the rate of emission during the experiment itself.¹³

Under these conditions the electron cloud exists without any significant loss of electrons for times of about 1.0 msec, which is the decay time constant of the field. We proved this by directly measuring the charge on a Faraday cup collected when the cloud is ejected out of the mirror at different times after injection.

The fact that the cloud is not fully neutralized can also be deduced from the Faraday cup signals. There are cases in which a short occurs in the injector at the end of the injection pulse; under these circumstances plasma is injected into the mirror and the cloud is fully neutralized. In this case we observe an oscillatory signal on the Faraday cup when ejecting the cloud. This is in contrast to the signal we observe under normal conditions (no short). [A typical Faraday cup signal is shown in Fig. 14. The current spikes observed are all below the baseline of the oscilloscope sweep (negative signal).]

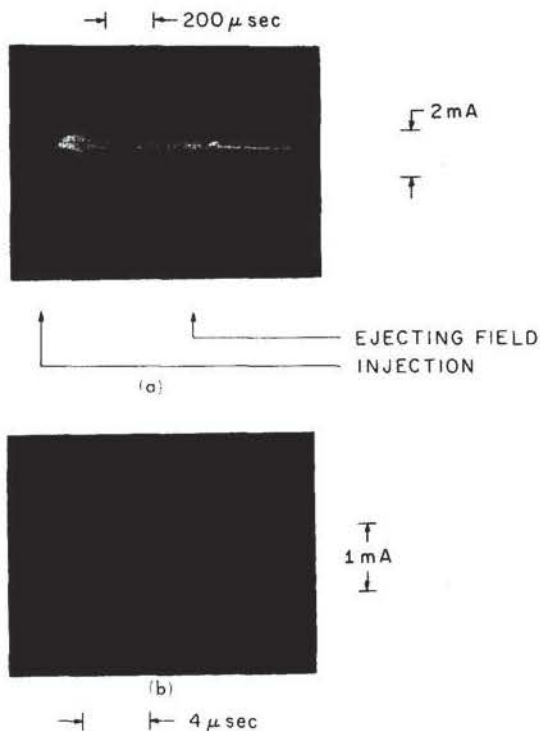

FIG. 8. (a) Electrostatic probe signal on a long time scale; notice the growth of the oscillation from the negative signal resulting from injection of net charge into the system. The current scale shown is obtained from dividing the voltage scale on the oscilloscope by the termination resistance of 50Ω . (b) Electrostatic probe signal at $250 \mu\text{sec}$ after injection on a short time scale.

3. Electrostatic oscillation of the cloud and modulation of the Faraday cup signals

a. *Electrostatic oscillations.* Previous experiments with nonneutral electron plasmas have shown that an electrostatic probe which measures currents induced

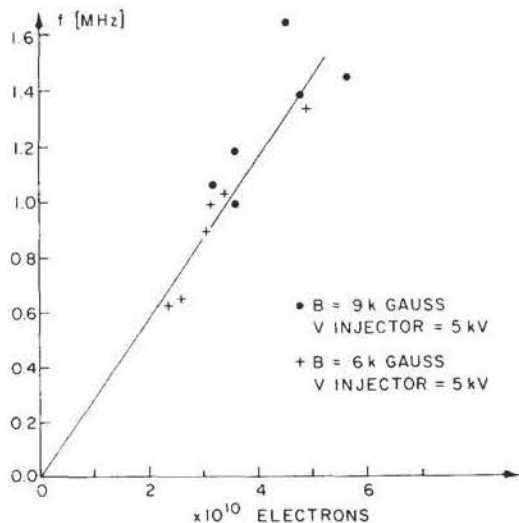

FIG. 9. Electrostatic oscillation frequency as a function of measured ejected number of electrons for a field with a mirror ratio of 1.35 and for two different peak values of the field at the midplane. The accuracy of measuring the charge from the Faraday cup signal is estimated to be $\pm 10\%$.

because of charge motion in the confining volume measures oscillatory signals with frequencies in the megahertz range. Daugherty *et al.*⁵ interpreted the oscillation as the diocotron¹⁵ oscillation and used the frequency of the oscillation as a measure of the amount of injected charge. Kapetanakos *et al.*⁸ have observed a very similar oscillation, but found some evidence which showed that the oscillations seen on the capacitive probe cannot originate in the diocotron mode.

We observed very similar oscillations in our experiment with capacitive probe signals. Figure 8 shows the signal seen on the capacitive probe with two different time bases. Figure 8(a) is the envelope of the oscillation. Figure 8(b) is on a shorter time base and one can see the detailed structure of the oscillation. In Fig. 8(a) the oscillation starts almost immediately after injection; the negative part of the signal comes from the net charge induced on the probe because of injected electrons. The oscillation is stopped abruptly at a certain stage because the ejecting field was operated.

The result of the measurement of the dependence of oscillation frequency upon trapped charge is shown in Fig. 9. The amount of trapped charge in each shot was measured by ejecting the cloud on the Faraday cup and measuring the current pulse. The shots were done with two different peak values of the magnetic field as indicated in the figure. The injector voltage is the same for all points in the figure and the amount of injected charge was changed by changing the filament temperature. The dependence is close to linear on the range covered by this measurement.

Figure 10 is a measurement of the same kind done for a different magnetic field configuration. The mirror ratio is reduced to 1:1.18. In this case the charge was measured by integrating the x-ray pulse signal so that we have no absolute calibration of the charge scale. The x-ray pulses during ejection were detected by the 7.5×7.5 cm plastic scintillator which was located at a

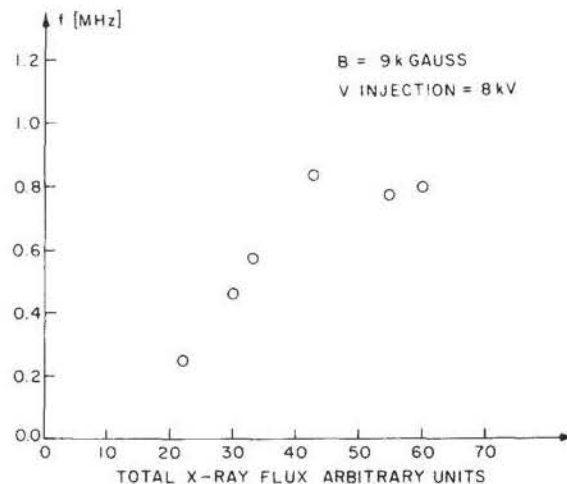

FIG. 10. Electrostatic oscillation frequency as a function of total measured x-ray flux. The mirror ratio in these measurements was 1.18.

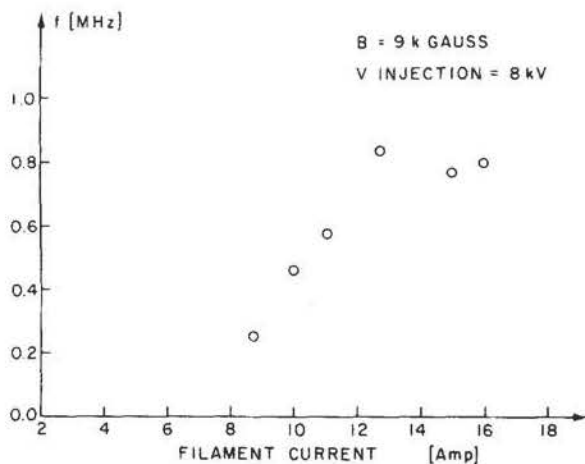

FIG. 11. Electrostatic oscillation frequency as a function of filament current. The points in this figure correspond to the same shots used in Fig. 10.

distance of 100 cm from the mirror midplane. We used this different method of measuring the number of trapped electrons since it is not limited like the Faraday cup measurement by the fact that the electrons have to hit the collector in order to be detected. Since the electrons have to hit the walls of the vacuum chamber during ejection and since the distance between the experiment and the detector is large compared with the dimensions of the experiment, the integrated x-ray signal is proportional to the number of trapped electrons. The result seems very similar to the previous result. The amount of injected charge was changed by changing the filament temperature while the injector voltage was kept constant. Figure 11 is a plot of the same shots where this time the frequency is plotted as a function of the measured filament current; the result is again similar to Fig. 10.

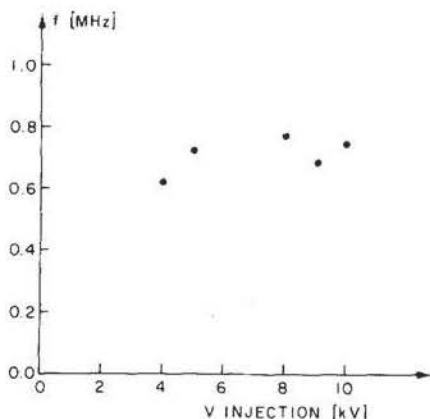

FIG. 12. Electrostatic oscillation frequency as a function of injector voltage. The oscillation frequency is normalized to the amount of trapped charge measured for each point so that the accuracy of the measured frequency is $\pm 10\%$. All shots are done with a magnetic mirror ratio of 1.18 and peak magnetic field of 9 kG.

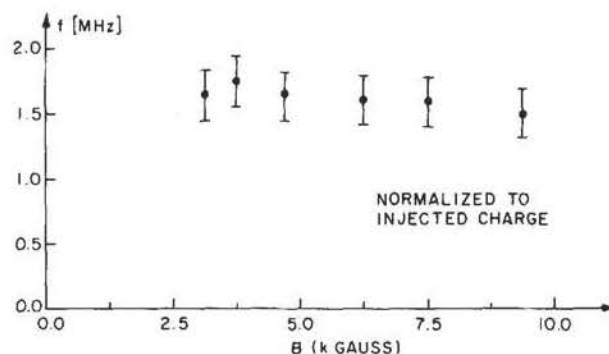

FIG. 13. Electrostatic oscillation frequency as a function of peak magnetic field at mirror midplane. The frequency is normalized to the measured amount of trapped charge in each shot. All shots were done with a mirror ratio of 1.35 and with an injector voltage of 5 kV.

Figure 12 is a plot of the frequency dependence upon injector voltage. Since the injected charge does change with the injector voltage, we normalized each frequency to the measured charge based upon the linearity demonstrated in Fig. 9. The peak magnetic field was kept at a constant value of 9 kG and the mirror ratio in these shots was 1.18:1. Over the range of 4 to 10 kV injection energy the oscillation frequency is independent of the injector voltage for a constant charge in the cloud.

Finally, we measured the frequency dependence upon the magnetic field. This is given in Fig. 13. (The error bars in Fig. 13 come from the normalization of the measured frequency to the measured trapped charge, the same error is also applicable to the frequency values of Fig. 12.) Again, we normalized the measured frequency value to the measured injected charge since there is a reduction of about 50% in the amount of injected charge for the lowest magnetic field. The oscillation frequency is independent of the magnetic field value over a range of 1:3 in the magnetic field. These measurements were done with a constant injector voltage of 5 kV. All the results shown in Figs. 9 to 13 were done with the injector located near the high mirror maximum.

The results presented here are in contrast to previously quoted results⁸ which showed that for a similar experiment the oscillation frequency was independent of the number of trapped electrons while it did depend on the injection voltage. It showed, as in our case, that the frequency was independent of the value of the magnetic field. The dependence upon injection voltage shown in that experiment might, in our opinion, simply be a result of the change in the amount of trapped charge with the injector voltage. Had we not normalized our measurements of frequency as a function of voltage to the trapped charge, we would have obtained the same result. We think that by using these three independent diagnostics to measure the amount of trapped charge we have proved that under our experimental conditions the observed electrostatic oscillation is a collective mode and cannot be explained only by single particle motion.

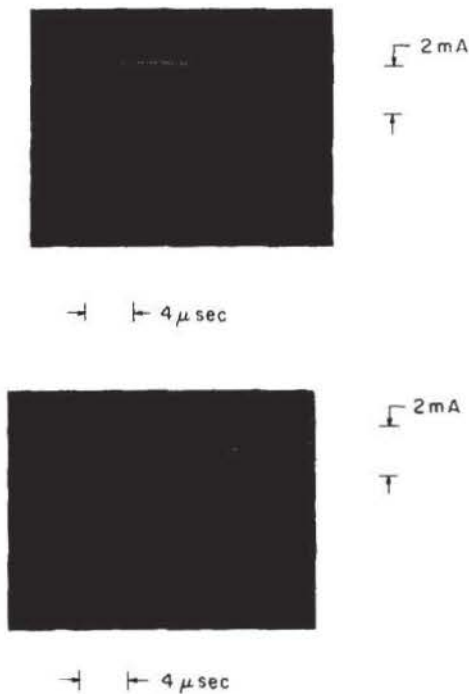

FIG. 14. Faraday cup traces for two different shots. Both shots were done with a mirror ratio of 1.35, a peak magnetic field of 9 kG and 5 kV injection energy.

b. Modulation of the ejected signal. The current pulse measured on a Faraday cup and also the x-ray signal measured with a scintillation detector are usually not a single spike pulse but contain a few spikes spaced at equal time intervals. Moreover, the modulation frequency has a direct connection to the oscillation frequency observed on the capacitive probe. Figure 14 shows typical Faraday cup traces. Both shots were made at the same peak magnetic field and injection voltage values, and they differed only by the amount of injected charge. The frequency of the appearance of the current pulses is seen to be higher for a higher total charge.

Figure 15(a) shows the trace of the capacitive probe measured during ejection for the same shots shown in Fig. 14. The dark part at the center of the trace is because of direct electrical pickup on the capacitive probe during operation of the capacitor bank ignitrons. [Figure 15(b) shows the probe response to the ejecting field when everything is operated in the experiment except the heating of the filament.] We see, therefore, that the oscillations survive after the ejecting field is operated and that the oscillation frequency is lower than the frequency before the ejecting field is activated. Moreover, as with the Faraday cup modulation, the frequency is decreasing together with the whole signal that approaches zero as the mirror ratio approaches unity. The frequency of the oscillation on the capacitive probe is equal to the frequency of appearance of the peaks on the Faraday cup to within 5% when they are measured at the same time. This was verified for 15 shots.

Finally, the x-ray flux pictures show the same modulation as the Faraday cup. The upper trace in Fig.

16(a) is the trace of the x-ray signal during ejection while the lower trace on the same figure is the signal of the Faraday cup for the same shot. The Faraday cup was located on axis in this shot. In Fig. 16(b) we show a different shot under the same conditions, but the Faraday cup axis is located 1.5 cm off the experiment axis. The collector on the Faraday cup is 2 cm in radius so that the collector still covers the experiment axis. Under these conditions we get a very similar pulse shape on the Faraday cup while the x-ray detector shows some additional pulses which correspond to electrons missing the collector but hitting other parts of the system at different times.

We have done some measurements of the radial distribution of the ejected cloud by this method of moving the Faraday cup radially while keeping its axial position (Fig. 1) and measuring the x-ray and Faraday cup signals. From these measurements we conclude that the ejected cloud has a diameter of less than 2 cm and is cylindrically symmetric. We also conclude that when the Faraday cup is located on axis, it measures more than 95% of the ejected electron cloud. The accuracy of this method is limited by the size of the Faraday cup collector so one cannot obtain a detailed radial distribution in this way.

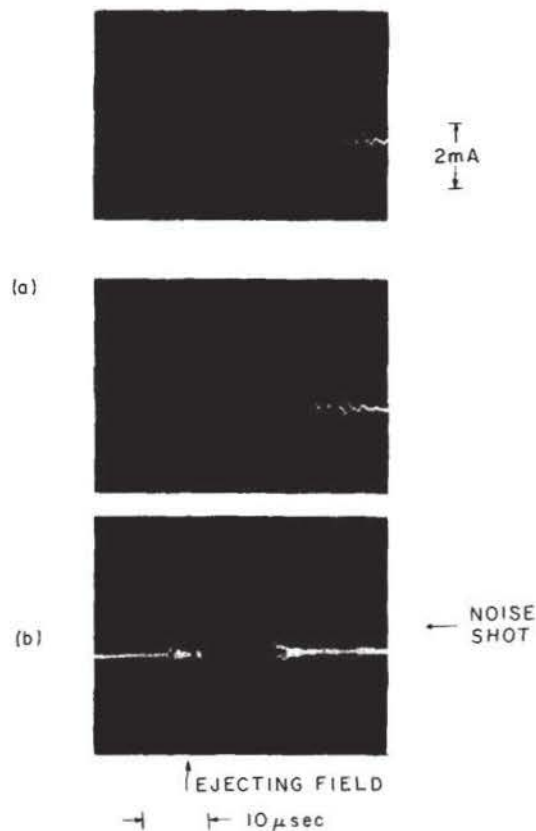

FIG. 15. (a) Capacitive probe signals during ejection. The traces are for the two events shown in Fig. 14 and are in the same order. (b) The response of the capacitive probe to the noise during operation of the ejecting field. This shot is done under the same conditions as part (a), but with no filament heating.

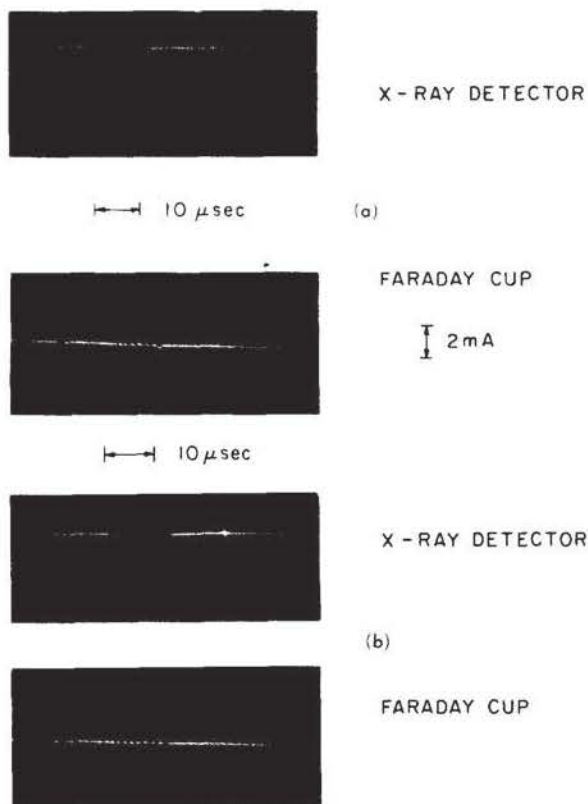

FIG. 16. (a) X-ray pulse and Faraday cup pulse for a shot in which the Faraday cup is located on axis and all electrons hit the collector. (b) X-ray pulse and Faraday pulse for a shot in which the Faraday cup collector is located 1.5 cm off axis. Some electrons miss the collector while they still appear on the x-ray detector at different times since they might hit different parts of the system.

c. Discussion. We believe that the evidence presented here is quite conclusive about the collective nature of the observed oscillations. However, their origin and what they really consist of are still open questions. Trying to identify them as the diocotron mode causes some difficulties as already discussed by Kapetanakis *et al.*⁸ If we assume that the charge is spread out over the whole mirror length for a cloud of 10^{11} electrons, we have a charge density of 1.6×10^{-7} C/m; and for a radius of 5 cm of the conducting wall we find that the frequency¹⁶ of the $m = 1$ mode should be 0.18 MHz for a 10 kG field. This is about an order of magnitude lower than the observed frequency. This is not too bad considering the fact that the formula we are using is for an infinitely long cylinder and we do not know what the real length of our cloud is. Another problem is that the formula predicts a dependence of the form¹⁶ $f \sim 1/B$ for the diocotron frequency which we did not observe.

Another question is what is the origin of the modulation we observe on the ejected cloud? The simplest explanation of this phenomena is that the cloud is either expanding and contracting longitudinally or that the whole cloud is oscillating back and forth along the z axis. Each cycle ejects part of the electron cloud through the weaker side of the mirror. Another ex-

planation might be that a transverse motion of the cloud is projecting part of the electrons into the loss cone of the mirror each time. In both cases, this motion will induce an oscillating signal on the electrostatic probe.

V. CONCLUSIONS

We have conducted experiments on electron clouds trapped in magnetic mirrors, studied two possible methods of radial injection, investigated some of the cloud equilibrium properties and gathered further information about the cloud by ejecting it out of the mirror. Some of the conclusions are:

- (i) Injection is possible by placing the injector in the mirror midplane and a collective effect governs the injection.
- (ii) Injection is also possible by placing the injector near the mirror maximum and the injection has a single particle behavior characteristic.
- (iii) An electrostatic collective oscillation was detected and its frequency depends linearly upon the total charge in the cloud, but not upon the magnetic field or injection energy.
- (iv) A similar oscillation has also been observed in ejected current pulses seen on a Faraday cup and x-ray detector.

ACKNOWLEDGMENTS

Useful discussions with C. W. Roberson are gratefully acknowledged. The good skills of our glass blower, G. Mayer, were very helpful in this research.

This work was supported by the National Science Foundation Grant No. PHY76-12856.

- ¹V. I. Veksler, in *Proceedings of the CERN Symposium on High Energy Accelerators and Pion Physics*, Geneva, 1956 (CERN Scientific Information Service, Geneva, 1956), Vol. 1, p. 80.
- ²D. Keefe, G. R. Lamberton, L. J. Laslett, W. A. Perkins, J. M. Peterson, A. M. Sessler, R. W. Alison, Jr., W. W. Chupp, A. W. Luccio, and J. B. Rechen, *Phys. Rev. Lett.* **22**, 558 (1969).
- ³V. P. Sarentsev, *IEEE Trans. Nucl. Sci.* NS-16, 15 (1969).
- ⁴L. Brillouin, *Phys. Rev.* **67**, 260 (1945); R. C. Davidson, and N. A. Krall, *Phys. Rev. Lett.* **22**, 833 (1969).
- ⁵J. D. Daugherty, J. E. Eninger, and G. S. Janes, *Phys. Fluids* **12**, 2677 (1968).
- ⁶W. Clark, P. Korn, A. Mondelli, and N. Rostoker, *Phys. Rev. Lett.* **34**, 575 (1975).
- ⁷A. Mohri, M. Masusaki, T. Tzukui, and K. Ikuta, *Phys. Rev. Lett.* **34**, 574 (1975).
- ⁸C. A. Kapetanakis, R. E. Pechacek, D. A. Spero, and A. W. Trivelpiece, *Phys. Fluids* **14**, 1555 (1971).
- ⁹A. Fisher, in *Proceedings of the 9th International Topical*

Conference on Electron Beam Research and Technology
(Sandia Laboratories, Albuquerque, New Mexico, 1975),
Vol. II, p. 312.

¹⁰Yu. E. Kolyada, E. A. Kornilov, and Ya. B. Fainberg, *Zh. Tekh. Fiz.* **43**, 2170 (1973) [*Sov. Phys.-Tech. Phys.* **18**, 1364 (1974)].

¹¹R. C. Davidson, A. T. Drobot, and C. A. Kapetanacos, *Phys.*

Fluids **16**, 2199 (1973).

¹²A. Irani and N. Rostoker, *Part. Accel.* **8**, 107 (1978).

¹³J. D. Daugherty, J. Eninger, and G. S. Janes, AVCO
Everett Research Laboratory Report No. 375 (1971).

¹⁴W. A. Hull, *Phys. Rev.* **18**, 13 (1921).

¹⁵R. H. Levy, *Phys. Fluids* **8**, 1288 (1965).

¹⁶R. H. Levy, *Phys. Fluids* **11**, 920 (1968).