

Lawrence Berkeley National Laboratory

Recent Work

Title

THERMODYNAMICS OF OXYGEN ORDERING IN $\text{YBa}_2\text{Cu}_3\text{O}_z$

Permalink

<https://escholarship.org/uc/item/3q36k2vb>

Authors

Wille, L.T.

Berera, A.

Fontaine, D. de

Publication Date

1987-12-01



Lawrence Berkeley Laboratory

UNIVERSITY OF CALIFORNIA

Materials & Chemical
Sciences Division

RECEIVED
LAWRENCE
BERKELEY LABORATORY

MAR 4 1988

Submitted to Physical Review Letters

LIBRARY AND
DOCUMENTS SECTION

Thermodynamics of Oxygen Ordering in $\text{YBa}_2\text{Cu}_3\text{O}_z$

L.T. Wille, A. Berera, and D. de Fontaine

December 1987

For Reference

Not to be taken from this room



LBL-24581
1

DISCLAIMER

This document was prepared as an account of work sponsored by the United States Government. While this document is believed to contain correct information, neither the United States Government nor any agency thereof, nor the Regents of the University of California, nor any of their employees, makes any warranty, express or implied, or assumes any legal responsibility for the accuracy, completeness, or usefulness of any information, apparatus, product, or process disclosed, or represents that its use would not infringe privately owned rights. Reference herein to any specific commercial product, process, or service by its trade name, trademark, manufacturer, or otherwise, does not necessarily constitute or imply its endorsement, recommendation, or favoring by the United States Government or any agency thereof, or the Regents of the University of California. The views and opinions of authors expressed herein do not necessarily state or reflect those of the United States Government or any agency thereof or the Regents of the University of California.

LBL-24581

Thermodynamics of Oxygen Ordering in $\text{YBa}_2\text{Cu}_3\text{O}_z$

by

L. T. Wille, A. Berera* and D. de Fontaine

Materials and Chemical Sciences Division
Lawrence Berkeley Laboratory
and Department of Materials Science and Mineral Engineering
University of California
Berkeley, CA 94720

*Department of Physics
University of California, Berkeley, CA 94720

December 1987

This work was supported by a grant from the Director, Office of Energy Research, Materials Sciences Division, U. S. Department of Energy, under contract DE-AC03-76SF00098.

THERMODYNAMICS OF OXYGEN ORDERING IN $\text{YBa}_2\text{Cu}_3\text{O}_z$.

L.T. Wille, A. Berera * and D. de Fontaine †

Materials and Chemical Sciences Division
Lawrence Berkeley Laboratory
Berkeley, CA 94720

* Department of Physics
University of California
Berkeley, CA 94720

† Department of Materials Science and Mineral Engineering
University of California
Berkeley, CA 94720

ABSTRACT

The partial ordering in the Cu-O basal plane of $\text{YBa}_2\text{Cu}_3\text{O}_z$ has been investigated as a function of oxygen content and temperature. A phase diagram is calculated by means of the Cluster Variation Method applied to an asymmetric two-dimensional Ising model. The interaction parameters selected guarantee the stability of the experimentally observed double-cell structure around $z = 6.5$. The transition temperatures at various oxygen partial pressures are in good agreement with experiment. The pair probabilities along the Cu-O chains show a plateau with varying oxygen concentration, not unlike the dependence of T_c on oxygen content.

PACS numbers : 74.70.Ya, 61.50.Ks, 64.60.Cn, 81.30.Hd

It is by now well established¹⁻³ that $\text{YBa}_2\text{Cu}_3\text{O}_z$ can exist in at least two different structures, depending on the overall oxygen content and the ordering of the oxygen atoms in the Cu-O basal plane. In the tetragonal ($P4/mmm$) phase the oxygen sites are occupied at random and the material is not superconducting. The high- T_c (92 K) compound possesses orthorhombic ($Pmmm$) symmetry and contains O-Cu-O chains, believed to be responsible for superconductivity in this and related oxides. Near $z = 6.5$ an ordered double-cell phase has been observed by transmission electron microscopy and diffraction³; its superconducting transition temperature T_c appears to drop to about 60 K².

In previous work⁴⁻⁵, the stability of these structures was derived rigorously on the basis of a two-dimensional Ising model with symmetric first neighbor interaction V_1 and asymmetric second neighbor interactions V_2 and V_3 , the first one linking oxygen sites through the Cu ions, the second one linking those without an intermediate Cu, as shown in Fig. 1a. Effective pair interactions can in principle be calculated by imposing an ordering perturbation on a completely disordered (three-dimensional) medium, in the spirit of the Generalized Perturbation Method⁶. However, since no electronic structure calculations for the completely disordered material have been performed, the V_n were considered as parameters, and various stability regions were mapped out⁴⁻⁵. For simplicity, these interactions were assumed to be both concentration and temperature independent. The model thus features two phenomenological parameters, the ratios V_2/V_1 and V_3/V_1 , with $V_1 > 0$ to insure nearest neighbor ordering. Ordered structures with twice and four times the original square unit cell were found to occur for various ranges of these parameter ratios⁵. In particular for $V_1 > 0$, $V_2 < 0$ and $0 < V_3 < V_1$, the ordered arrangement of filled and vacant sites in the basal plane is predicted to be that shown in Fig. 1a for planar concentration of oxygen $c_o = 0.50$ ($z = 7.0$) and that shown in Fig. 1b for $c_o = 0.25$ ($z = 6.5$). In the latter figure, cell doubling is seen to occur along the a direction of the simple orthorhombic structure (the Cu-O-Cu chains lie along the b direction). Such is the structure reported by Van Tendeloo et al³. The purpose of the present communication is to present, for the first time, a two-dimensional Ising-model

phase diagram with these two structures as ground-states. Accordingly, canonical values $V_1 = 1$, $V_2 = -0.5$ and $V_3 = 0.5$, are used since they guarantee the existence of the proper ordered superstructures, thus ensuring that the phase diagram will have the correct topology.

The statistical thermodynamical model used is the Cluster Variation Method (CVM)⁷. Previous work along similar lines⁸⁻¹² did not differentiate between V_2 and V_3 and therefore did not contain the cell-doubling phase. The calculations were performed in the four- and five-point cluster approximation of the CVM, leading to entropy expressions containing 25 linearly independent correlation functions for the single cell phase and 41 for the double cell. It has been established previously¹² that this gives very accurate phase diagrams; for example, the CVM result at $V_2 = V_3 = 0$ is only 4% higher than the exact Onsager solution for the transition temperature at zero field. Moreover, since the CVM is formulated in terms of correlation functions, it contains a wealth of information about ordering parameters, not easily accessible to other methods.

The resulting CVM phase diagram is shown in Fig. 2. Only one half of the full diagram is shown, since, under the assumption of constant effective pair interactions, it is necessarily symmetric about the oxygen concentration $c_o = 0.50$ ($c_o = \frac{1}{2}(z-6)$). The single-phase regions are denoted by two-dimensional space group symbols : $p4mm$, corresponding to the three-dimensional tetragonal phase ($P4/mmm$), and $p2mmI$ and $p2mmII$ for the single and double cell orthorhombic phases respectively. The high temperature tetragonal phase is separated from the ordered single cell phase by a line of second order transitions (line b-c). Since the minimization of the CVM free energy becomes ill-posed at low temperatures, no calculated data are available at temperatures below $kT/V_1 \cong 0.8$, but conjectured extrapolations are indicated by dotted lines. Point b appears to be a bicritical point, and a schematic representation of phase equilibrium lines in its vicinity is shown in the inset of Fig. 2 : two lines of second-order transitions (c-b and t-b) meet two first-order phase boundary lines, the separation of which is shown in an exaggerated manner in the inset. The second-order transi-

tions are allowed by the Landau rules. The thin dashed line indicates the metastable $\langle 00 \rangle$ ordering instability or spinodal¹³. Other instability limits may be constructed in the vicinity of the bicritical point¹⁴, a topic which will be investigated further in a future publication¹⁵.

A previous CVM calculation¹² for the symmetric case $V_2 = V_3$ showed good agreement with published Monte Carlo¹⁷ and renormalization group¹⁸ calculations. In such diagrams, cell-doubling is absent and second- and first-order transitions meet at a tricritical point, below which a very wide two phase region is found. It follows that solubility of oxygen in p4mm and vacancies in p2mmI must become vanishingly small at low temperatures. In the present asymmetric interaction case, the p2mmII phase region breaks up the p4mm + p2mmI two phase field, but the low solubility character of low and high concentration phase is not expected to be altered. The (dotted) extrapolations in Fig. 2 have been constructed accordingly. It also follows that the line of second-order transitions between the ordered phases I and II must terminate, at low enough temperatures, at a tricritical point, for example at the conjectured point marked t in Fig. 2. The presence of a low temperature tricritical point allows the width of the p2mmII phase region to go to zero as the temperature is lowered since it is expected that, at 0 K, the double-cell phase will be stable only at the precise stoichiometry $c_o = 0.25$ ($z = 6.5$).

The orthorhombic to tetragonal transition has been found experimentally to have second-order character. Transition temperatures and oxygen content for oxygen partial pressures of 5×10^{-3} , 2×10^{-2} , 10^{-1} , 2×10^{-1} and 1 atm. were determined recently by a group at the Oak Ridge National Laboratory¹⁹. These experimental points are shown as open circles in Fig. 2, with transition temperatures increasing monotonically with partial pressure. One point, that at 0.02 atm., was used to fit the temperature scale (see 'estimated temperature' in degrees K at right of Fig. 2). All other points were then found to fall very nearly on the line b-c of calculated second-order transitions. Moreover, the Oak Ridge group reports an irreversible transformation below about 725 K with very sluggish kinetics¹⁹. Significantly, the transition

is predicted to be a first-order one between tetragonal and cell-doubling phases. The latter structure was not observed by Specht et al¹⁹, however, due to the experimental difficulty of attaining thermodynamic equilibrium.

It must be emphasized that the choice of V_2/V_1 and V_3/V_1 ratios used in the computation is not expected to be the optimal one. Actually, the phase diagram of Fig. 2 was calculated before the experimental data had become available. Preliminary results indicated that, with slight changes of the interaction parameter ratios, the agreement between measured and calculated points can be improved further. Partial pressure curves calculated with the new parameters will be presented in a future publication¹⁵.

A large number of independent cluster correlation functions can be determined within the CVM. For example, point correlations are related to the fractional site occupancies x_o^α , x_o^β and $x_o^{\alpha_1}$, $x_o^{\alpha_2}$ and x_o^β for the single and double cell phases, respectively, the superscripts indicating sublattices, as illustrated in Fig. 1a and b. Sublattice 'point' probabilities essentially measure the degree of long range order, whereas pair probabilities, such as n.n. (nearest neighbor, x_1) and n.n.n. (next nearest neighbor, x_2), measure short range order (SRO). Here, x_1 refers to SRO between the α and β sublattices, while x_2 refers to SRO within a given sublattice in a given crystallographic direction. Of particular interest are x_2^α (for p2mmI) and $x_2^{\alpha_1}$ and $x_2^{\alpha_2}$ (for p2mmII), since these pair probabilities determine SRO along the O-Cu-O chains within the oxygen-rich sublattice, and hence must be intimately connected to superconducting properties.

Values of these x_2 probabilities are plotted in Fig. 3a as a function of oxygen concentration c_o for the fixed temperature $kT/V_1 = 0.9$. As expected at this relatively low temperature, ordering is almost complete at $c_o = 0.50$, then decreases practically linearly with decreasing oxygen concentration. The second-order transition from I to II is encountered at about $c_o \cong 0.31$, at which point sublattices α_1 and α_2 must be distinguished. The full curve in Fig. 3a represents the average pair probability $\frac{1}{2}(x_2^{\alpha_1} + x_2^{\alpha_2})$, which exhibits a slope change at

$c_o \cong 0.31$, decreasing at first more slowly than would have been the case for the metastable extension of the I-phase (dashed curve). Both dashed and full curves drop rapidly below $c_o \cong 0.26$ corresponding to the maximum ordering temperature of the II-phase region. The dashed curve must change slope discontinuously as the metastable extension of the high temperature ordering line (the $\langle 00 \rangle$ spinodal) is crossed, at about $c_o \cong 0.23$, since SRO is now that pertaining to the (metastable) disordered state. As for the equilibrium SRO curve (full line), after dropping linearly in the narrow two-phase region, it rejoins the x_2 curve for the disordered state. Figure 3b shows the behavior of $x_2^{\alpha_1}$ (upper dashed line) and $x_2^{\alpha_2}$ (lower dashed line) in the cell doubling region. The average is plotted as a full line, and corresponds to the full line in Fig. 3a over the same concentration range. The rapid decrease of the average pair probability appears to be due to the existence of a pronounced maximum in the O-Cu-O correlation on the α_1 sublattice. Correspondingly, the O-Cu-O correlations on the α_2 sublattice go through a minimum which would in fact be zero for perfect $p2mmII$ ordering. It is important to note, however, that pair probabilities for oxygen atoms parallel to the a axis do not show any structure similar to Fig. 3.

It is tempting to relate the O-Cu-O pair probability curve with its plateau-like behavior to the plot of the value of the superconducting transition temperature T_c as a function of oxygen content as determined experimentally by Cava et al^{2,17}. In particular, it is suggested here that the 60 K T_c phase observed in the range $z = 6.56$ to 6.7 ($c_o = 0.28$ to 0.35) is indeed the predicted $p2mmII$ phase, the cell-doubling character of which has been observed by electron microscopy and diffraction³. If indeed the presence of O-Cu-O chains is closely related to the existence of a high T_c , it is reasonable to expect that the II-phase, containing, at stoichiometry, only half the density of chains of the I-phase, should have a lower T_c than that of the single cell phase.

To summarize : a CVM calculation was performed on a two-dimensional anisotropic Ising model with first (V_1) and second (V_2 and V_3) neighbor interactions. The ratios

V_2/V_1 and V_3/V_1 were chosen so as to stabilize both single cell (p2mmI) and double cell (p2mmII) ordered ground states. It was subsequently found that, by fitting the magnitude of V_1 , experimentally determined¹⁹ transition points could be made to fall very nearly on the calculated line of second order transitions. Furthermore, the O-Cu-O cluster probability as a function of oxygen content, calculated at 725 K, exhibited a plateau-like behavior, not unlike the one observed by Cava et al^{2,17} for the concentration dependence of the superconducting transition temperature. The fact that the cell-doubling phase has not always been observed in bulk samples must be due to the very sluggish oxygen kinetics below 450 C, which is the highest temperature at which this phase is expected to be stable according to the present calculation. Moreover, the plane-to-plane correlation may be highly imperfect in the three-dimensional solid.

Confirmation of the position of the second order transition line would require experiments to be performed at high overpressure of oxygen and at high temperatures where, in fact, other 'incoherent' phase changes may occur. The temperature scale on the left of Fig. 2 and the concentration scale at the bottom of the figure are those of the two-dimensional order-disorder model, the estimated temperature scale on the right depends on the parameter fit and is therefore approximate. The oxygen content scale (z) at the top of the figure is correct only under the assumption that all oxygen concentration changes occur exclusively in the 'basal planes'.

Acknowledgments.

This work was supported by the Director, Office of Basic Energy Sciences, Materials Sciences Division of the U. S. Department of Energy under Contract No. DE-AC03-76SF00098 and by a National Foundation Graduate Fellowship to AB. Helpful conversations with Prof. S. C. Moss, Dr. H. W. Zandbergen, Dr. J. D. Jorgensen and Mr. M. Sluiter are gratefully acknowledged. The authors also thank Drs. E. D. Specht and C. J. Sparks for permission to include in Fig. 2 their as yet unpublished data.

References.

1. J. D. Jorgensen, M. A. Beno, D. G. Hinks, L. Soderholm, K. J. Volin, R. L. Hitterman, J. D. Grace, I. K. Schuller, C. V. Segre, K. Zhang and M. S. Kleefisch, Phys. Rev. B36, 3608 (1987).
2. R. J. Cava, B. Batlogg, C. H. Chen, E. A. Rietman, S. M. Zahurak and D. Werder, Phys. Rev. B36, 5719 (1987).
3. G. Van Tendeloo, H. W. Zandbergen and S. Amelinckx, Sol. St. Comm. 63, 603 (1987).
4. D. de Fontaine, L. T. Wille and S. C. Moss, Phys. Rev. B36, 5709 (1987).
5. L. T. Wille and D. de Fontaine, Phys. Rev. B (in press).
6. F. Ducastelle and F. Gautier, J. Phys. F 6, 2039 (1976).
7. R. Kikuchi, Phys. Rev. 81, 988 (1951).
8. H. Bakker, D. O. Welch and O. W. Lazareth, Sol. St. Comm. 64, 237 (1987).
9. E. Salomons, N. Koeman, R. Brouwer, D. G. de Groot and R. Griessen, Sol. St. Comm. (1987).
10. J. M. Bell, preprint.
11. A. G. Khachatryan, S. V. Semenovskaya and J. W. Morris, preprint.
12. A. Berera, L. T. Wille and D. de Fontaine, J. Stat. Phys. (in press).
13. D. de Fontaine, Solid State Physics 34, 73 (1979).

14. S. M. Allen and J. W. Cahn, in "Alloy Phase Diagrams", (L. M. Bennett, T. B. Massalski and B. C. Griessen, eds.), Materials Research Society Proceedings **19**, 195 (1983).
15. A. Berera, L. T. Wille and D. de Fontaine, to be published.
16. K. Binder and D. P. Landau, Phys. Rev. B **21**, 1941 (1980).
17. F. Claro and V. Kumar, Surf. Sci. **119**, L371 (1982).
18. R. J. Cava, B. Batlogg, C. H. Chen, E. A. Rietman, S. M. Zahurak and D. Werder, Nature **329**, 423 (1987).
18. E. D. Specht, C. J. Sparks, A. G. Dhere, J. Brynstad, O. B. Cavin, D. M. Kroeger and H. A. Oye, submitted to Phys. Rev. B.

Figure Captions.

1. Ground states in the Cu-O basal plane; small filled circles are Cu-atoms, O denotes oxygen atoms, \square vacant sites.

(a) at $c_o = .50$ two sublattices α and β are present;

(b) at $c_o = .25$ a cell-doubling phase gives rise to sublattices α_1 , α_2 and β .

Pair interactions V_1 , V_2 and V_3 are sufficient to stabilize these structures.

2. Phase diagram obtained from CVM calculation, dotted lines are conjectured extensions. The diagram contains a bicritical point (b) and a tricritical point (t). Open circles : experimental data of Specht et al¹⁹.

3. Second neighbor oxygen-oxygen pair probabilities through Cu-atoms at $kT/V_1 = 0.9$.

(a) Full line : equilibrium probabilities; dashed line metastable extension of single cell phase.

(b) Decomposition of double-cell probabilities: upper (lower) dashed line corresponds to oxygen rich (poor) sublattice; full line is the average value.

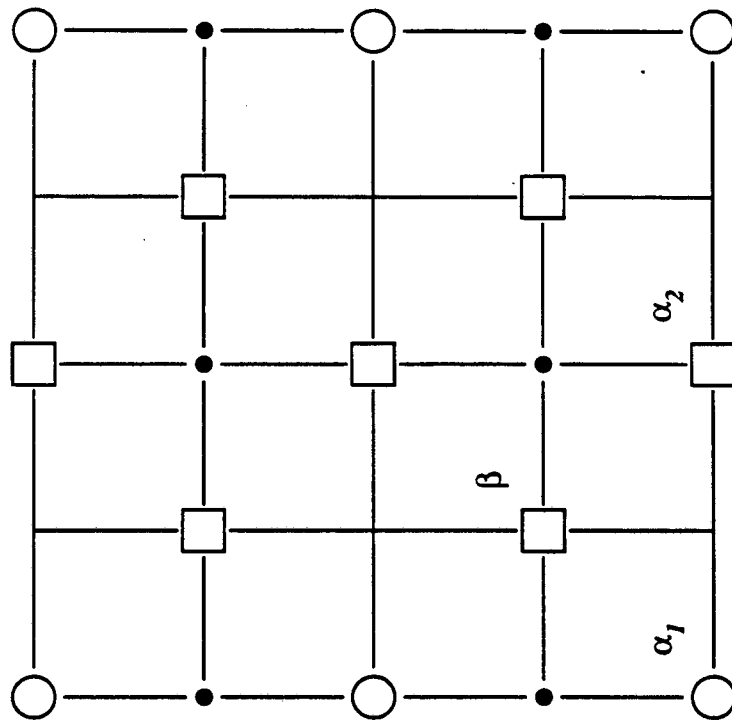

(a)

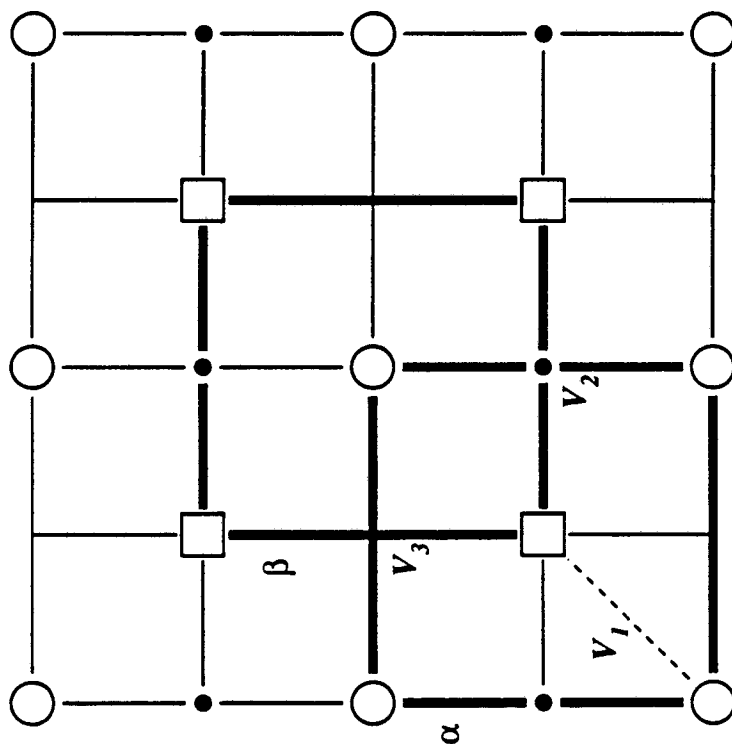

(b)

XBL 881-48

Fig. 1

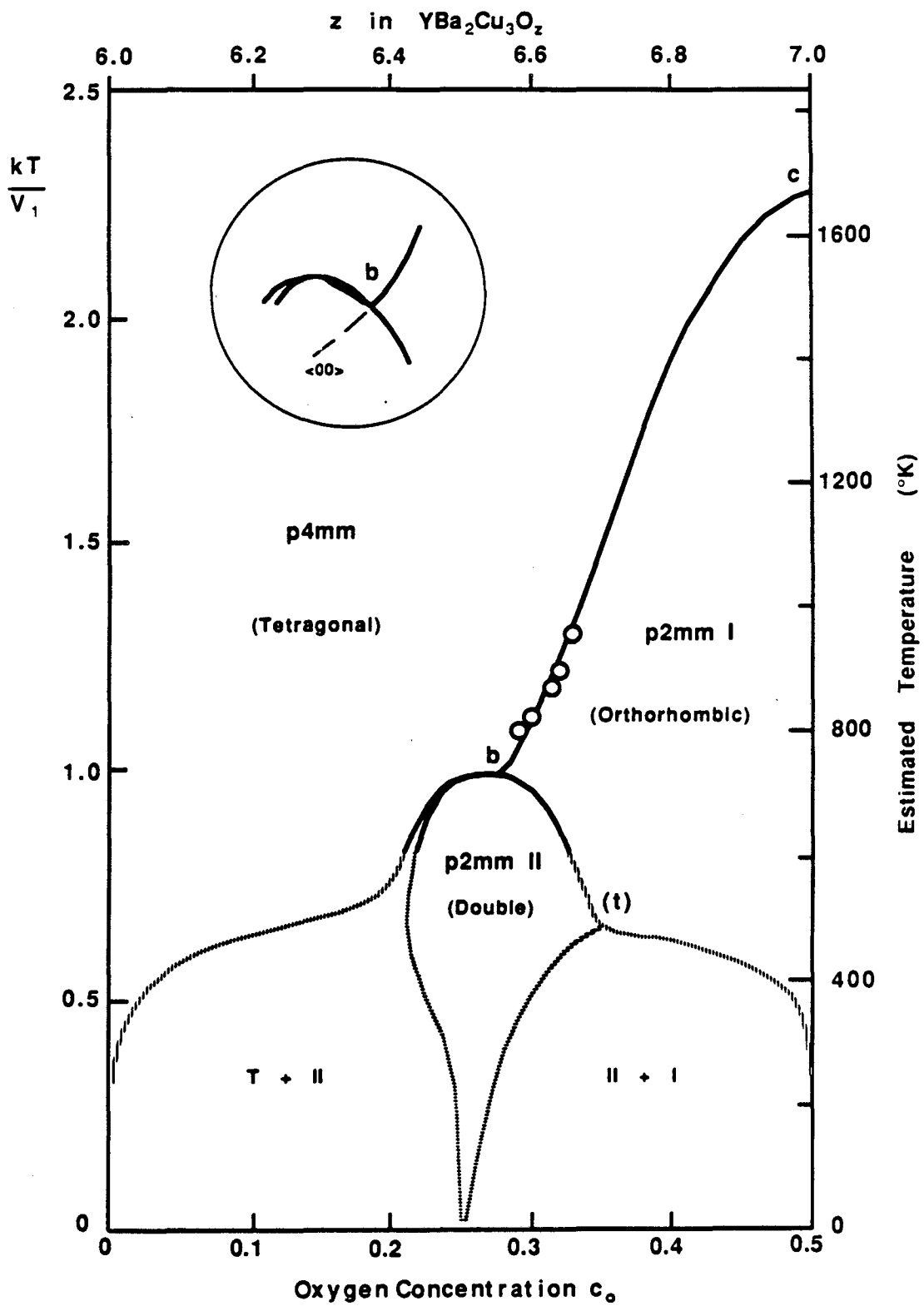

XBL 881-49

Fig. 2

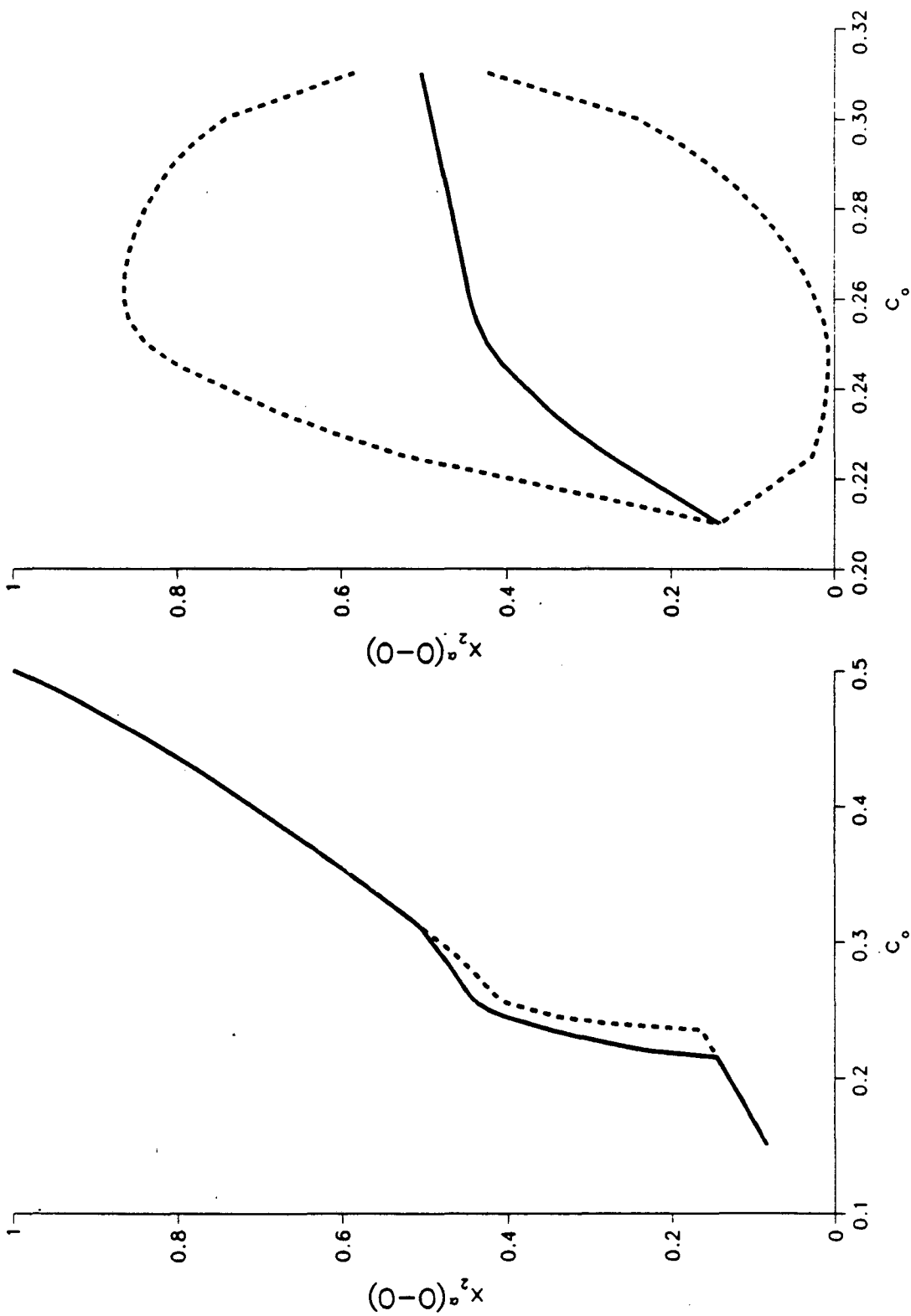

XBL 881-50

Fig. 3

*LAWRENCE BERKELEY LABORATORY
TECHNICAL INFORMATION DEPARTMENT
UNIVERSITY OF CALIFORNIA
BERKELEY, CALIFORNIA 94720*