

UC San Diego

SIO Reference

Title

Maps of sky luminance at various altitudes

Permalink

<https://escholarship.org/uc/item/3g22f5kw>

Authors

Duntley, Seibert Q

Bioleau, A R

Harris, J L

et al.

Publication Date

1960-02-01

Visibility Laboratory
University of California
Scripps Institution of Oceanography
San Diego 52, California

MAPS OF SKY LUMINANCE AT VARIOUS ALTITUDES

S. Q. Duntley, A. R. Boileau, J. L. Harris and J. Gordon

February 1960
Index Number NS 714-100

Bureau of Ships
Contract NObs-72092

SIO REFERENCE 60-12

Approved:

Approved for Distribution:

Selbert Q. Duntley
Selbert Q. Duntley, Director
Visibility Laboratory

Roger Revelle
Roger Revelle, Director
Scripps Institution of Oceanography

Maps of Sky Luminance at Various Altitudes

Seibert Q. Duntley, Almerian Boileau,
Jacqueline Gordon and James L. Harris

Visibility Laboratory, Scripps Institution of Oceanography,
University of California, San Diego, California

The Visibility Laboratory has instrumented a B-29 aircraft for documentation of the optical properties of the atmosphere within the visible spectrum. Two of the instruments are hemispherical scanners, one for the upper hemisphere and one for the lower hemisphere. These scanners measure the luminance of the upper and lower hemispheres. They have 5° resolution and require approximately $1\frac{1}{2}$ minutes for a complete scan. The instruments are photopically corrected and the data is therefore reported in the photometric units of foot-lamberts.

On 21 September 1956 a flight was made between Pueblo, Colorado and Peterson Air Force Base. The following figures are isoluminance plots derived from the upper and lower scanners on this flight.

Figure 1 shows the upper hemisphere as measured on the ground at Peterson Air Force Base. The readings are in foot-lamberts. The scale factor between successive heavy lines is approximately 2.3. The lowest luminance shown is 0.436×10^3

foot-lamberts and the highest value is 6.3×10^4 (in the vicinity of the sun) which represents the saturation level of the scanner. The flight was in the late afternoon and the sun's elevation was approximately 13° . North is 98° bearing from the sun. The terrain to the west is mountainous which explains the detail shown on the western horizon.

Figure 2 is an isoluminance plot of the upper hemisphere taken at 7000 feet altitude. The range of readings is the same. It may be noticed that the 0.436×10^3 foot-lambert profile has increased in size corresponding to a decrease of zenith luminance with altitude. North is 100° bearing from the sun and the sun elevation is 15° .

Figure 3 is the upper hemisphere at 15,000 feet altitude and shows a further increase in the size of the 0.436×10^3 foot-lambert profile. North is 104° bearing from the sun and the sun's elevation is 19° .

Figure 4 is the upper hemisphere for 20,000 feet altitude. The lowest contour shown is now approximately 0.19×10^3 foot-lamberts. North is 109° bearing from the sun and the sun elevation is 24° .

Figure 5 is the lower hemisphere as recorded at 20,000 feet altitude. The inner contour is 10^3 foot-lamberts and

represents a bright spot in the field. The sun elevation was 24° so that the bright spot corresponds to the angle of direct reflectance from the sun, The lowest contour shown in the figure is 10^3 foot-lamberts. The day was described as clear with scattered clouds between 16,000 and 17,000 feet altitude.

21 SEPTEMBER 1956
PIKES PEAK, COLO.
6,172 FT. ALTITUDE

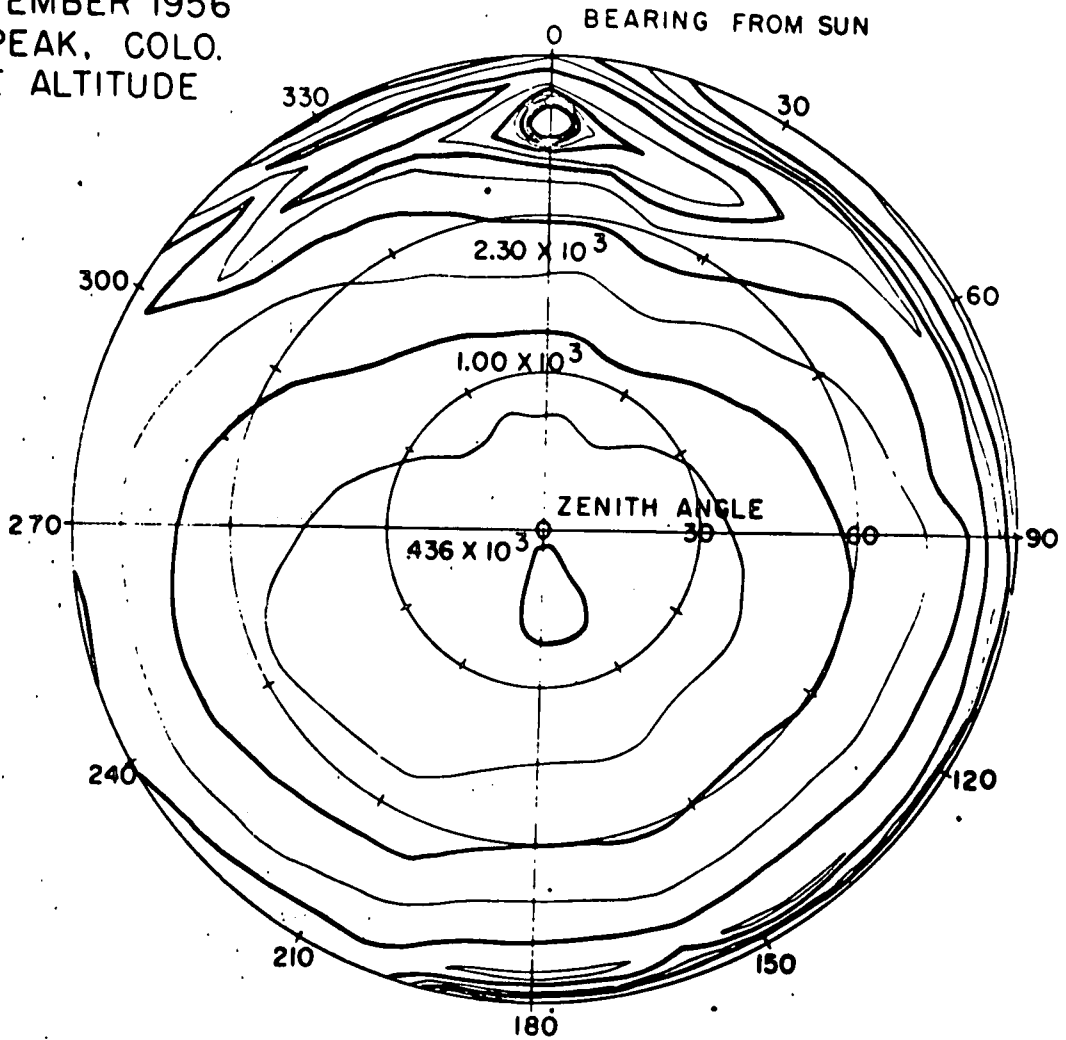

Figure 1. Upper hemisphere luminance distribution. Luminance is expressed in foot-lamberts.

21 SEPTEMBER 1956
PIKES PEAK, COLO.
7000 FT. ALTITUDE

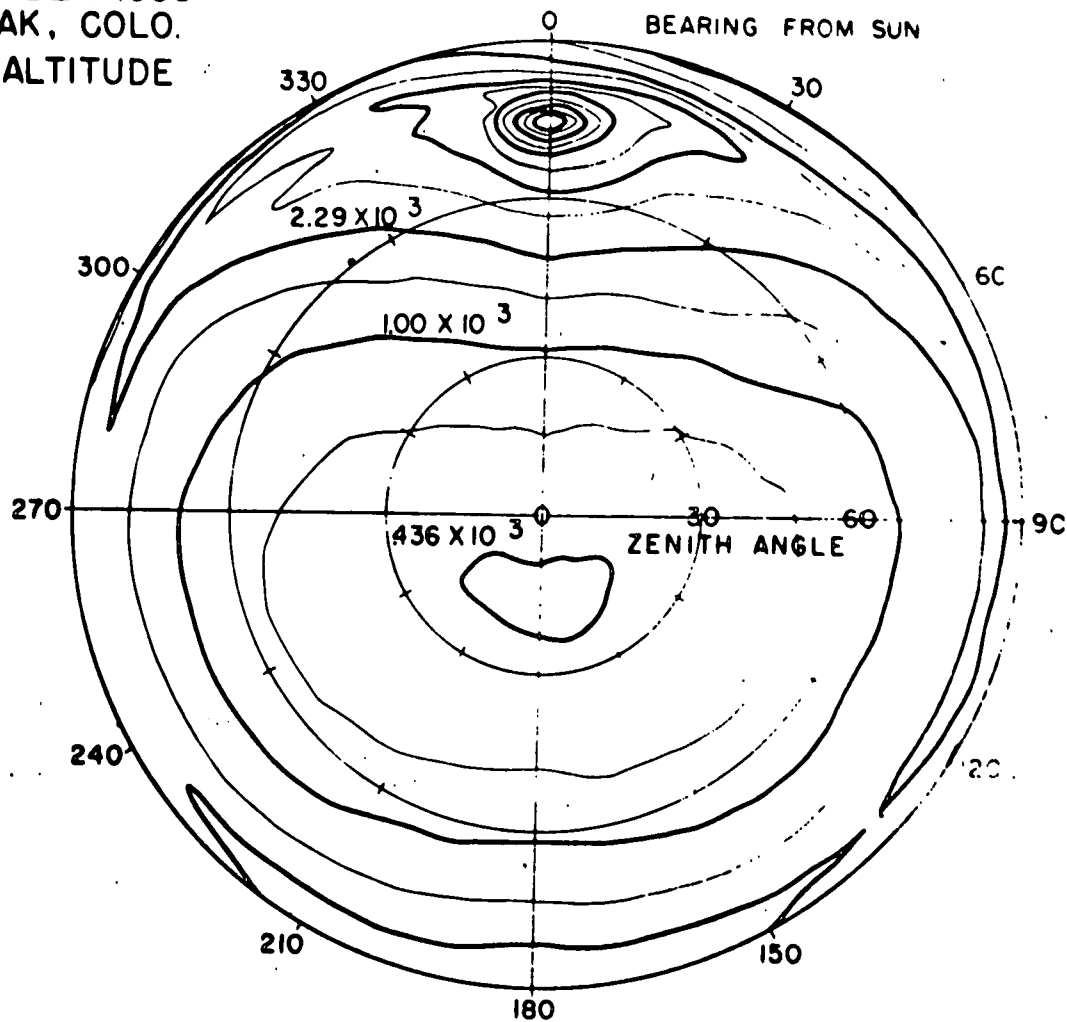

Figure 2. Upper hemisphere luminance distribution. Luminance is expressed in foot-lamberts.

21 SEPTEMBER 1956
PIKES PEAK, COLO.
15,000 FT. ALTITUDE

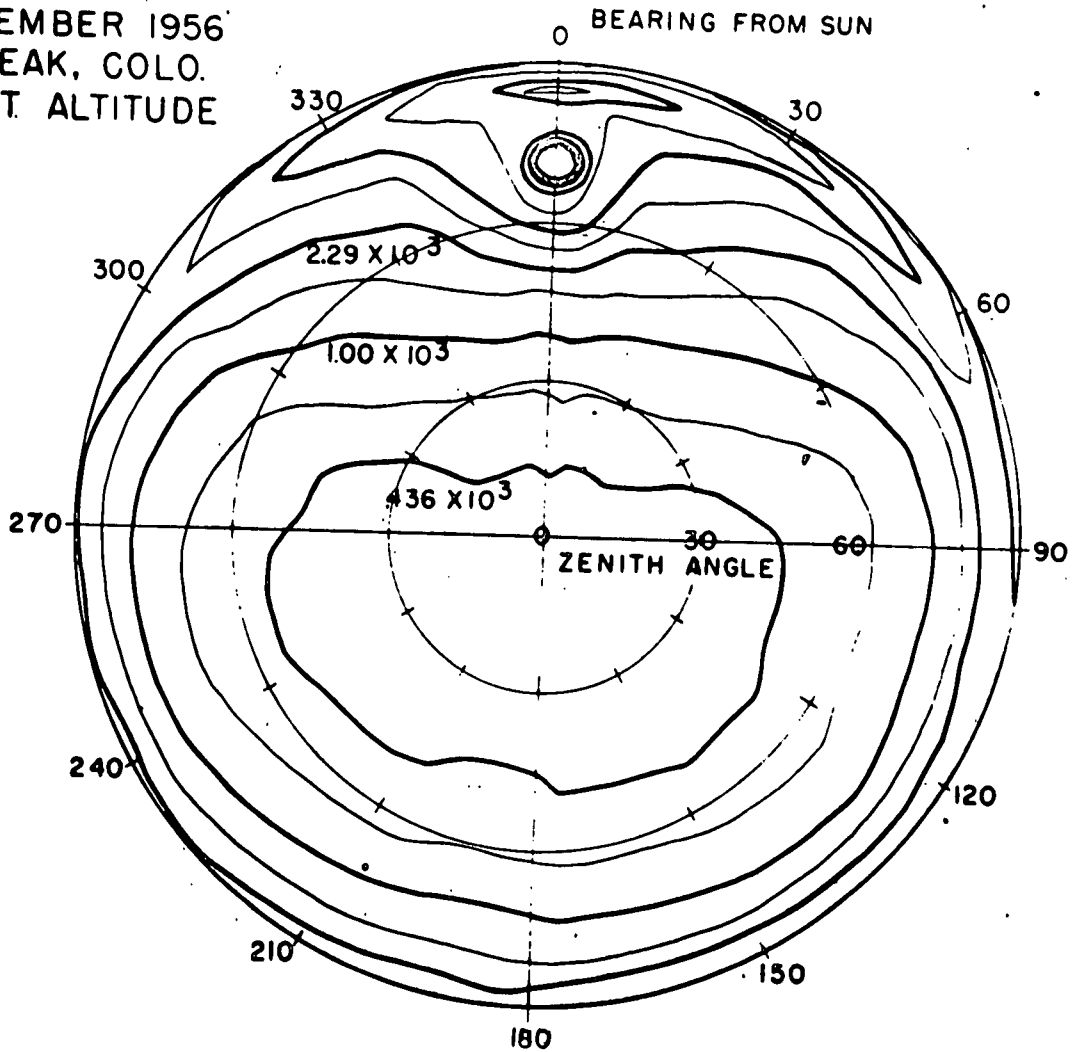

Figure 3. Upper hemisphere luminance distribution. Luminance is expressed in foot-lamberts.

21 SEPTEMBER 1956
PIKES PEAK, COLO.
20,000 FT. ALTITUDE

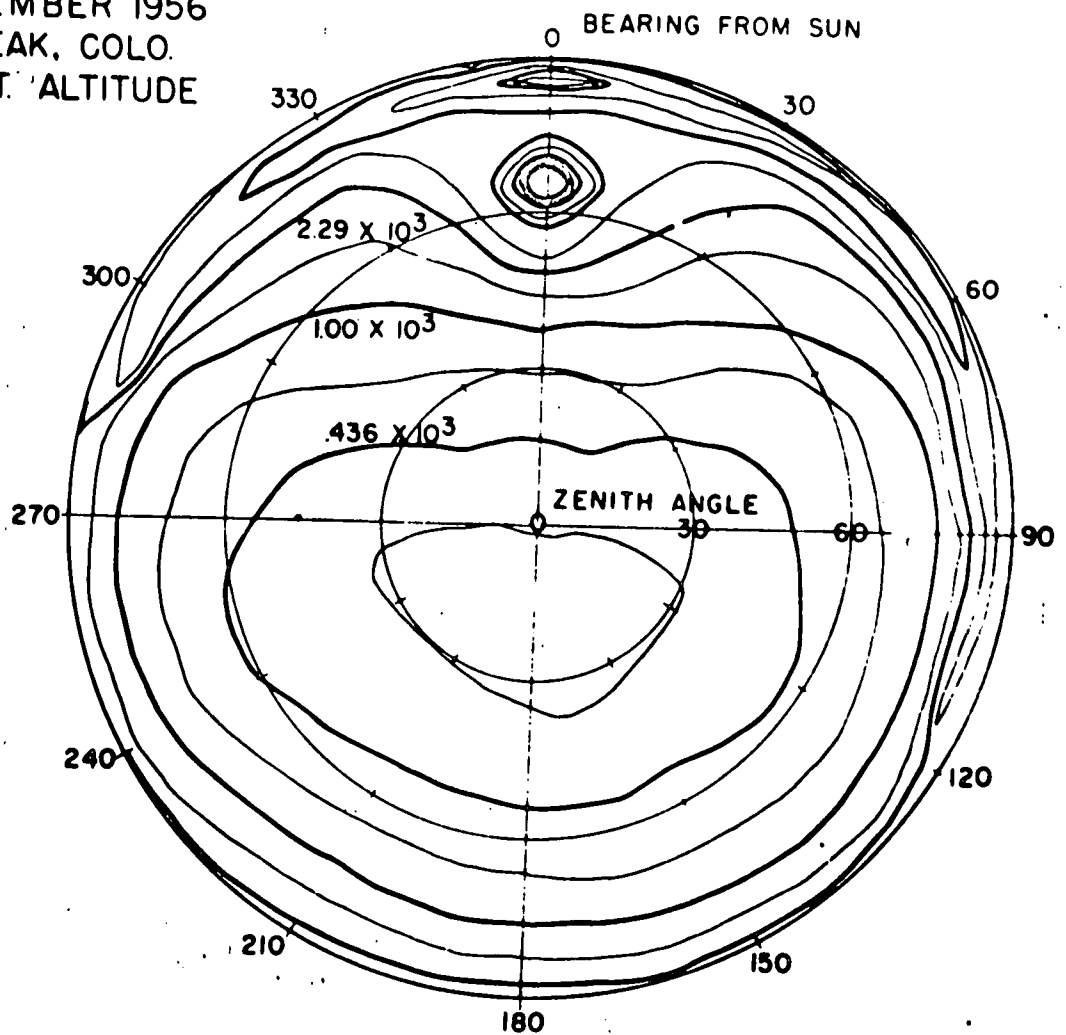

Figure 4. Upper hemisphere luminance distribution. Luminance is expressed in foot-lamberts.

21 SEPTEMBER 1956
PIKES PEAK, COLO.
20,000 FT. ALTITUDE

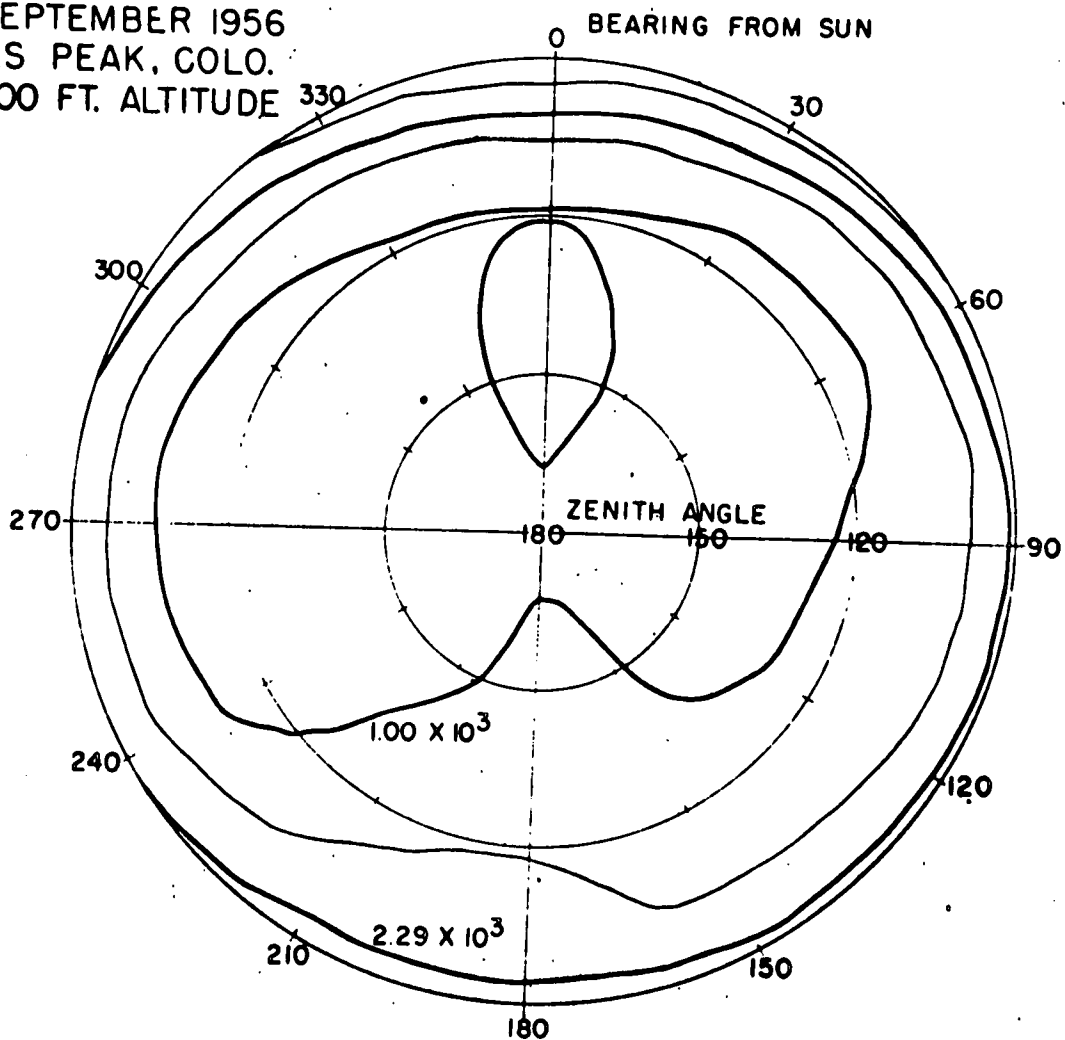

Figure 5. Lower hemisphere luminance distribution. Luminance is expressed in foot-lamberts.