

UC Berkeley

UC Berkeley Electronic Theses and Dissertations

Title

Effects of Advanced After-Treatment Control Technologies on Heavy-Duty Diesel Truck Emissions

Permalink

<https://escholarship.org/uc/item/3dc9s49f>

Author

Preble, Chelsea Victoria

Publication Date

2017

Peer reviewed|Thesis/dissertation

Effects of Advanced After-Treatment Control Technologies
on Heavy-Duty Diesel Truck Emissions

by

Chelsea Victoria Preble

A dissertation submitted in partial satisfaction of the
requirements for the degree of

Doctor of Philosophy

in

Engineering – Civil and Environmental Engineering

in the

Graduate Division

of the

University of California, Berkeley

Committee in charge:

Professor Thomas W. Kirchstetter, Co-Chair
Professor Robert A. Harley, Co-Chair
Professor Allen H. Goldstein
Professor S. Katharine Hammond

Spring 2017

Effects of Advanced After-Treatment Control Technologies
on Heavy-Duty Diesel Truck Emissions

Copyright © 2017 by

Chelsea Victoria Preble

Abstract

Effects of Advanced After-Treatment Emission Control Technologies on Heavy-Duty Diesel Trucks

by

Chelsea Victoria Preble

Doctor of Philosophy in Engineering – Civil and Environmental Engineering

University of California, Berkeley

Professor Thomas W. Kirchstetter, Co-Chair

Professor Robert A. Harley, Co-Chair

Heavy-duty diesel trucks are a major source of nitrogen oxides (NO_x) and the black carbon (BC) fraction of fine particulate matter (PM) in urban environments. These emissions contribute to persistent ozone and PM air quality problems. Recently, diesel particle filter (DPF) and selective catalytic reduction (SCR) emission control systems that target exhaust PM and NO_x, respectively, have become standard equipment on new heavy-duty diesel trucks. DPFs can also be installed as a retrofit. Additionally, the California Air Resources Board (CARB) has accelerated the adoption of these advanced emission control systems with two regulations: the Statewide Drayage Truck Regulation and the Truck and Bus Regulation. These rules required universal adoption of DPFs first by drayage trucks operating at ports and rail yards and second by most trucks and buses operating on arterial roadways and highways statewide. Prior studies, most of which have measured emissions from vehicles or engines operating on dynamometers in the laboratory, have shown DPF and SCR systems to be effective at reducing PM and NO_x emission rates. These studies have also identified potential changes to other co-emitted pollutants. There is concern that DPFs may promote the formation of ultrafine particles (UFP) and increase total particle number (PN) emissions while reducing particle mass emissions. The deliberate catalytic oxidation of engine-out nitric oxide (NO) to nitrogen dioxide (NO₂) in continuously regenerating DPFs may lead to increased tailpipe emissions of NO₂. NO₂ is a regulated air pollutant due its toxicity and its role in promoting the formation of other air pollutants such as ozone, nitric acid, and fine PM. While SCR reduces NO_x emissions, it may lead to increased emissions of nitrous oxide (N₂O), a potent greenhouse gas.

To evaluate the in-use performance of advanced emission control technologies on trucks operating on-road under real-world conditions, exhaust emissions from thousands of heavy-duty diesel trucks were measured over several years at the Port of Oakland and the Caldecott Tunnel in the San Francisco Bay Area. The adoption of DPF and SCR systems was greatly accelerated at these two locations due to new regulations, with phased implementation schedules. Gas- and particle-phase pollutants in the exhaust plumes of individual heavy-duty trucks were measured at high time resolution (≥ 1 Hz) as trucks were driven under a mobile emissions lab parked on an

overpass. Fuel-based emission factors (amount of pollutant emitted per kg of fuel burned) were calculated on a truck-by-truck basis via a carbon balance method. Emission profiles for each truck were linked to vehicle attributes, including engine model year and installed after-treatment controls, by matching recorded license plates to state-managed truck databases. With this information, trucks were categorized by emission control technology: (1) trucks without DPFs, (2) older engines retrofit with DPFs, (3) 2007–2009 model year engines equipped with DPFs at the time of manufacture, and (4) 2010 and newer engines equipped with both DPF and SCR systems at the time of manufacture.

In this dissertation, the impacts of advanced after-treatment control technologies on in-use heavy-duty diesel truck emissions are evaluated. During the phase-in of the Drayage Truck Regulation at the Port of Oakland, the impacts of DPF and SCR systems on drayage truck emissions were quantified by comparing pollutant emission rates for trucks with and without these control technologies. After full implementation of the regulation, changes to the fleet-average emissions and the durability of aging emission control systems were evaluated. The influence of driving mode on the performance of DPF and SCR systems was examined by comparing results for uphill, highway driving conditions at the Caldecott Tunnel versus driving on a flat, arterial roadway approaching the Port of Oakland.

DPF and SCR systems effectively reduced BC and NO_x emission rates from drayage trucks operating at the Port of Oakland. Trucks with 2010 and newer model year engines equipped with both DPF and SCR emitted on average $94 \pm 32\%$ less BC (average $\pm 95\%$ confidence interval) than trucks without particle filters. These 2010+ engines also emitted $76 \pm 7\%$ less NO_x than 1994–2006 engines without SCR. DPFs increased emissions of primary NO₂, however, by up to a factor of 6 for trucks with older engines—and higher baseline NO_x emissions—that had been retrofitted with DPFs. SCR systems partially mitigated these undesirable DPF-related NO₂ emissions, limiting the increase to a factor of 2 compared to trucks without filters. SCR systems can lead to the emission of N₂O, although the average emission rate by the drayage trucks at the Port of Oakland was below the California limit of 0.6 g kg^{-1} . Emissions of PN did not increase with use of DPFs. In fact, trucks with filters emitted fewer particles per kg of fuel burned, on average, compared to trucks without DPFs. The newest trucks with both DPF and SCR systems had the lowest PN emission rate, equal to one-fourth that for trucks without filters.

As a result of the Drayage Truck Regulation, the Port of Oakland drayage truck fleet was rapidly modernized to include DPF and SCR emission control systems. Between 2009 and 2015, the fraction of the fleet equipped with DPFs increased from 2 to 99%, SCR use increased from 0 to 25%, and the median engine age decreased from 11 to 7 years. Coincident with these changes, fleet-average emission rates of NO_x, BC, and PN decreased by $70 \pm 9\%$, $73 \pm 22\%$, and $74 \pm 27\%$, respectively. These reductions were achieved in two phases. The first phase focused on banning the oldest trucks from the Port, and requiring the universal adoption of DPFs over a three-year period ending in January 2013. The second phase took effect in the following year and replaced older trucks that had just recently been retrofit with DPFs, with newer 2007+ engines. As a result, SCR prevalence increased and this further reduced NO_x emissions beyond what was initially achieved in Phase 1. Use of SCR also helped to mitigate DPF-related increases in NO₂ emissions, which had doubled in Phase 1 relative to the previously uncontrolled truck fleet. Over

time, unfortunately, the BC emission rate for 2007–2009 engines with DPFs *increased* by 50%. This increase appears to be driven by deteriorating particle filter systems that led to some relatively high-emitting trucks. A small fraction of DPF-equipped trucks was responsible for a majority of the fleet BC emissions in 2015.

At the Caldecott Tunnel, there is similar evidence of deteriorating performance of diesel particle filters systems as they age. The effect on fleet-average BC emissions is smaller, and the overall performance of DPFs is comparable to what was measured at the Port of Oakland. SCR systems were more effective at reducing NO_x emissions at the Caldecott Tunnel compared to the Port. This difference is likely due to differences in driving conditions: truck engines are operating with higher power output due to the 4% uphill gradient and higher vehicle speeds. As a result, exhaust temperatures were higher and more likely to exceed the minimum temperature required for SCR operation. However, the elevated exhaust temperature also appears to have led to higher N₂O emission rates for SCR-equipped engines. At the Caldecott Tunnel, the N₂O emission rate for SCR trucks was more than double the emission rate by SCR-equipped drayage trucks operating at the Port of Oakland, and frequently exceeded the California limit.

PN emission rates also depend on driving mode, with higher exhaust temperatures promoting nucleation of ultrafine particles, and higher observed emissions of PN, by a factor of seven relative to the Port of Oakland in 2015. While DPFs at the Port of Oakland reduced emitted PN regardless of installation type, the effect of filters on PN emission rates at the Caldecott Tunnel depended on the type of DPF installed. Engines equipped with DPFs at the time of manufacture had comparable PN emission rates as observed from trucks without filters, whereas engines retrofitted with DPFs emitted 1.7 times more PN per unit of fuel burned.

This research demonstrates and documents the on-road effectiveness of advanced after-treatment control systems for reducing emission rates of black carbon and nitrogen oxides from diesel trucks. Emission control systems can alter the emission rate of co-emitted pollutants like primary NO₂, PN, and N₂O, in ways that depend on driving conditions. However, combined use of both DPF and SCR systems appears to offer the greatest air quality benefits: large reductions in both BC and NO_x emissions, as well as mitigation of DPF-related increases in tailpipe NO₂ emissions.

Future efforts to accelerate reductions in on-road vehicle emissions should focus on engine replacement rather than retrofitting in-use engines with DPFs. In order to maintain the air quality benefits of modern emission control systems over full in-use service lifetimes of on-road vehicles, it would be helpful to better understand why some diesel particle filter systems are failing prematurely, after less than ten years of service. The durability of emission control systems should be improved, and inspection and maintenance/repair programs may be helpful to identify, intervene, and fix the highest emitters that account for a minority of the on-road fleet but emit the majority of pollution.

Table of Contents

Acknowledgements	ii
Chapter 1: Introduction	1
1.1 Heavy-Duty Diesel Truck Emissions	1
1.2 Controlling Heavy-Duty Diesel Truck Emissions	3
1.3 Research Objectives	6
Chapter 2: Methods	7
2.1 Measurement Overview	7
2.2 Quality Assurance and Quality Control	14
2.3 Measurement Method Comparisons.....	20
Chapter 3: Effects of DPFs and SCR on Drayage Truck Emissions.....	26
3.1 Introduction	26
3.2 Results and Discussion.....	27
3.2.1 Accelerated Adoption of Emission Control Systems at the Port of Oakland.....	27
3.2.2 DPF and SCR Impacts on Average Emission Rates	28
3.2.3 Emission Factor Distributions	34
3.2.4 Emissions Variability and Representativeness.....	39
3.3 Conclusions	41
Chapter 4: Emissions Impacts of the Drayage Truck Regulation.....	42
4.1 Introduction	42
4.2 Results and Discussion.....	43
4.2.1 Changes to Port Truck Age Distribution	43
4.2.2 Changes in Emission Rates over Time	44
4.2.3 Nitrous Oxide	52
4.2.4 Emission Factor Distributions	53
4.2.5 DPF Deterioration	56
4.2.6 Emissions Variability of High-Emitters	60
4.3 Conclusions	60
Chapter 5: Driving Mode Impacts on DPF and SCR Performance.....	62
5.1 Introduction	62
5.2 Results and Discussion.....	63
5.2.1 Caldecott Tunnel Fleet Composition.....	63
5.2.2 Site Differences in Oxidized Nitrogen Emissions.....	65
5.2.3 Site Differences in Particle Number Emissions	70
5.2.4 DPF Durability	72
5.3 Conclusions	76
Chapter 6: Conclusions	77
6.1 Summary of Major Findings	77
6.2 Policy Implications and Recommendations for Future Research	80
References	82
Appendix	88

Acknowledgements

This work was supported by the California Air Resources Board, Bay Area Air Quality Management District, and National Science Foundation Graduate Research Fellowship Program. Thank you to Chandan Misra and Phil Martien for serving as project managers for these studies, and CalTrans for providing access at the Caldecott Tunnel. I would like to thank my collaborators—Tim Dallmann, Nathan Kreisberg, and Susanne Hering—for their time and expertise during the field measurements presented in Chapter 4. I would also like to extend my gratitude to Troy Cados and Nick Tang for their assistance with field measurements and data analysis presented in Chapters 5 and 6.

I cannot give enough thanks to my advisor, Tom Kirchstetter, who has provided me boundless advice and guidance since I first entered his lab as an undergraduate. His mentoring, encouragement, and bad jokes have been a constant source of inspiration. I must also thank Rob Harley, who has been an incredible co-advisor, providing insight, a heavy red pen, and a true sense of community amongst us Airheads. I would also like to thank the members of qualifying exam and dissertation committees, including Bill Nazaroff, Allen Goldstein, Kathie Hammond, and Ashok Gadgil, for pushing me to think beyond my focused area of research.

This dissertation would not have been possible without the amazing support of my family and friends. To my mom and my dad, thank you both for the endless love and pep talks. To my sister Mackenzie, thank you for being my #1 and keeping things silly so that I could stay sane. Grandma, thank you for all of the cookie care packages that kept me fueled throughout this work (and thank you, Poppa, for the QA/QC of those cookies). While these past five years have been a challenge, my friends, ENV cohort, and 605 Davis officemates have made also made them some of the greatest yet. Thank you!

Chapter 1: Introduction

Reproduced in part with permission from Preble, C.V., Dallmann, T.R., Kreisberg, N.M., Hering, S.V., Harley, R.A., Kirchstetter, T.W. 2015. Effects of particle filters and selective catalytic reduction on heavy-duty diesel drayage truck emissions at the Port of Oakland. *Environ. Sci. Technol.* 49, 8864–8871. doi:10.1021/acs.est.5b01117. Copyright 2015 American Chemical Society.

1.1 Heavy-Duty Diesel Truck Emissions

Heavy-duty diesel trucks are a major source of nitrogen oxides (NO_x) and diesel particulate matter (PM) emissions in the United States (Dallmann and Harley, 2010; McDonald et al., 2015). In California, heavy-duty diesel trucks were responsible for 30% of the NO_x and 39% of the diesel PM emitted statewide in 2012, as summarized in Table 1.1 (CARB, 2013). These emissions contribute to fine particulate matter (PM_{2.5}) and ozone air quality problems (Lloyd and Cackette, 2001; Morawska et al., 2008), and may lead to adverse health effects for exposed individuals (McClellan, 1987; Lloyd and Cackette, 2001; Brugge et al., 2007; IARC, 2012). Black carbon (BC) is a potent absorber of solar radiation and comprises the majority of diesel PM mass emissions (Ban-Weiss et al., 2008). On-road diesel trucks are the single largest source of BC in California, responsible for 17% of the state's total emissions (Table 1.1; CARB, 2015). Recent studies have suggested control of diesel BC emissions as a strategy to help mitigate global warming (Bond et al., 2013; Ramanathan et al., 2013). Such targeting of diesel BC emissions have been included in recent plans to reduce statewide emissions of short-lived climate pollutants as part of California's Global Warming Solutions Act, as codified by Senate Bills 605 and 1383 (CARB, 2017). Heavy-duty diesel trucks are currently a minor source of anthropogenic nitrous oxide (N₂O) emissions in California, contributing only 2.5% of statewide emissions (Table 1.1). However, N₂O is a potent greenhouse gas with a long atmospheric lifetime, and is the dominant ozone-depleting substance in the atmosphere (Ravishankara et al., 2009).

Table 1.1 Annual average statewide emissions by source category of NO_x, directly emitted (primary) PM_{2.5}, and diesel PM in 2012 (CARB, 2013), BC in 2013 (CARB, 2015), and N₂O in 2014 (CARB, 2016).

Source Category	NO_x (tons day⁻¹)	Primary PM_{2.5} (tons day⁻¹)	Diesel PM (tons day⁻¹)	BC (tons day⁻¹)	N₂O (tons day⁻¹)
On-Road Heavy-Duty Diesel Trucks	631	21	19	6	3
All Mobile Sources	1747	85	47	20	15
Statewide Total	2106	418	49	36	123

1.2 Controlling Heavy-Duty Diesel Truck Emissions

Increasingly stringent PM and NO_x emission standards have been established nationally to limit emissions from heavy-duty diesel trucks (Figure 1.1). The most recent standards for NO_x and PM are 98% lower than the initial limits set in 1988 (EPA, 2016) and are typically met using exhaust after-treatment control technologies. Trucks with 2007 and newer engines are equipped with a diesel particle filter (DPF) for PM control, and trucks with 2010 and newer engines also include selective catalytic reduction (SCR) systems for NO_x control. DPFs can be installed as retrofits on older engines that are already in use (van Setten et al., 2001). In addition to these national standards, California has instituted regulations requiring the retrofit and or replacement of older in-use engines with DPFs to accelerate emission reductions and air quality improvements (CARB, 2011; CARB, 2014).

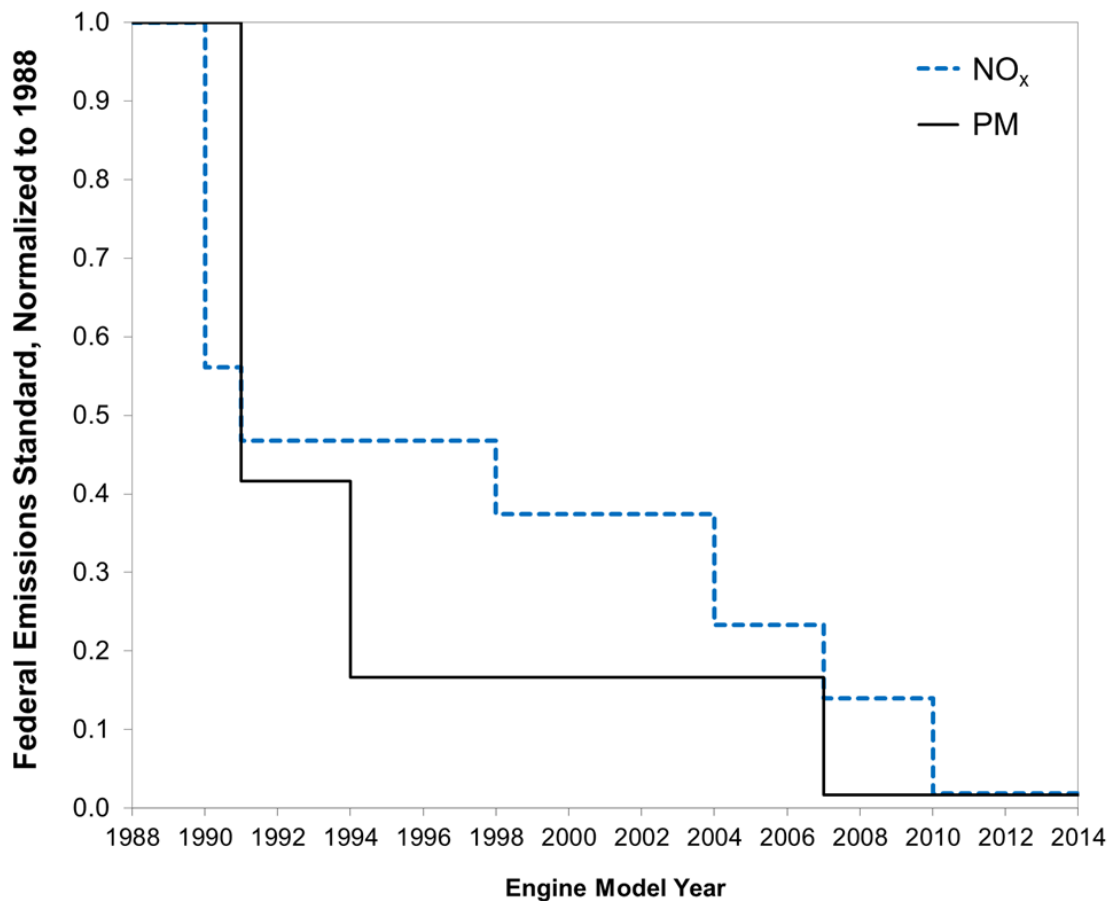

Figure 1.1 Heavy-duty diesel truck highway PM and NO_x exhaust emission standards set by the U.S. Environmental Protection Agency for each engine model year as a fraction of the initial limits set in 1988 (EPA, 2016).

Previous studies have shown that DPFs can reduce PM mass emissions from heavy-duty diesel engines by >90% (Biswas et al., 2008; Herner et al., 2009; Barone et al., 2010). Trapped carbon particles are oxidized to regenerate the filter either passively, by continuous reaction with nitrogen dioxide (NO₂) that is formed by catalytic oxidation of exhaust nitric oxide (NO), or actively, for example by periodic injection of fuel. The intentional conversion of NO to NO₂ in passively regenerated systems leads to increased primary NO₂ emissions and higher NO₂/NO_x emission ratios (Shorter et al., 2005; Herner et al., 2009; Bishop et al., 2012; Dallmann et al., 2012). These emissions changes are of concern because NO₂ is toxic and increased primary NO₂ emissions promote ozone formation. Another concern is that DPF-related reductions in overall particle mass emissions may favor increased homogeneous nucleation rather than condensation of gases onto existing particle surfaces, thereby increasing formation of ultrafine particles (UFP) and total particle number (PN) emissions (Kittelson, 1998; Biswas et al., 2008; Herner et al., 2011). UFP (diameters < 0.1 μm) can induce inflammatory and oxidant stress responses that have been linked to cardiovascular disease and mortality (Oberdörster, 2001; Sioutas et al., 2005; Ostro et al., 2015). The increases in NO₂ and UFP emissions are both associated with high catalytic loading within the DPF and high exhaust temperatures (Herner et al., 2009, 2011).

Performance of SCR systems controlling NO_x emissions has been shown to depend on truck driving mode. SCR systems do not operate under cold start conditions or at low engine/low vehicle speed (Misra et al., 2013). This driving mode dependence results from the minimum exhaust temperature required for SCR operation. If this minimum operational temperature is not met, urea injection is deliberately disabled and the SCR system is not functional. Such urea injection control prevents SCR catalyst deactivation via the formation of ammonium sulfate and/or nitrate or the incomplete decomposition of urea at low exhaust temperatures (Havenith and Verbeek, 1997; Koebel et al., 2001; Koebel et al., 2002; Sluder et al., 2005). In fully functional SCR systems, urea fully decomposes to ammonia (NH₃), which reduces engine-out NO_x to nitrogen (N₂). Oxidation of ammonia in the presence of excess NO₂ and oxygen (O₂) at high temperatures can lead to formation of N₂O. At lower temperatures, decomposition of ammonium nitrate that is formed under conditions where the ratio of NH₃ to NO_x is higher can also lead to the formation of N₂O (Hallstrom et al., 2013).

In California, the phase-in and use of DPF and SCR technologies has been greatly accelerated as the result of two statewide regulations: the Statewide Drayage Truck Regulation and the Truck and Bus Regulation. The phased implementation schedules for these two regulations are summarized in Table 1.2 and Table 1.3, respectively. The first regulation applies to drayage trucks, which are commonly used for short-haul freight transport at ports and rail yards. Over a three-year period between January 2010 and December 2012, all drayage trucks were required to be equipped with DPFs, either via retrofit or engine replacement. By January 2014, all drayage trucks in the state were required to be equipped with a 2007 or newer engine (CARB, 2011). The second regulation applies to most on-road heavy-duty diesel trucks and buses operating in California. Between January 2012 and December 2013, non-exempt trucks with 1996 and newer model year engines were required to install DPFs. Between January 2015 and December 2016, the rule required replacement of pre-1996 model year engines with 2010 or newer engines that are equipped with both DPF and SCR systems (CARB, 2014a).

Table 1.2 Phased implementation schedule for the California Air Resources Board’s Statewide Drayage Truck Regulation (CARB, 2011).

Phase of Regulation	Deadline	Engine Model Year	Requirement
Phase 1	January 2010	1993 & Older	Banned
		1994–2003	Retrofit with DPF or replace with newer engine
	January 2012	2004	
	January 2013	2005–2006	
Phase 2	January 2014	1994–2006	Replace with 2007 or newer engine

Table 1.3 Implementation schedule for the California Air Resources Board’s Truck and Bus Regulation (CARB, 2014a).

Deadline	Engine Model Year	Requirement
January 2012	1996–1999	Retrofit with DPF or replace with newer engine
January 2013	2000–2004	
January 2014	2005–2006	
January 2015	Pre-1994	Replace with 2010 or newer engine
January 2016	1994–1995	

The long-term durability of these after-treatment control technologies has yet to be established, although this question is starting to receive increased attention (Bishop et al., 2015). Compared to engines without SCR, the SCR-equipped engines are tuned to deliver higher power output with resulting increased engine-out NO_x emissions (Misra et al., 2013). Consequently, control system failure in these trucks could lead to an increase in NO_x emissions relative to trucks without SCR. Therefore, to understand air pollution and related public health and climate change impacts of widespread DPF and SCR system use, it is critical to evaluate how these emission control technologies perform under real-world conditions as engines and emission control equipment age.

1.3 Research Objectives

The goal of this research is to characterize the impact of advanced emission control technologies on gas- and particle-phase pollutant emissions from in-use heavy-duty diesel engines. Specifically, this work will address the following research questions:

1. What is the in-use, real-world effectiveness of advanced emission control technologies in reducing exhaust PM and NO_x emissions?
2. Do new emission control technologies have effects on other co-emitted pollutants?
3. How durable are these new emission control systems over time?
4. Do differences in driving mode affect conclusions about pollution emissions and performance of advanced emission control technologies?

To address these research questions, heavy-duty diesel truck emissions were measured over a period of several years at the Port of Oakland and the Caldecott Tunnel. Both measurement sites are located in the San Francisco Bay Area. At the Port of Oakland, drayage trucks haul shipping containers in and out of the Port. The drayage truck fleets serving California ports were modernized rapidly following enactment of the Statewide Drayage Truck Regulation, the first of two regulations aimed at mitigating vehicle-related air pollution in California. The Caldecott Tunnel serves a more diverse fleet, including drayage and non-drayage trucks (e.g., cement mixers, dump trucks, tractor trailers, flatbeds, and construction equipment). This broader fleet was also subject to fleet modernization requirements, under the Truck and Bus Regulation.

Chapter 2 describes methods that were used to measure the air pollutants in diesel exhaust plumes and how fuel-based emission factors were calculated for individual trucks. Chapter 3 quantifies the impacts on emissions from deploying advanced emission control technologies on in-use heavy-duty diesel trucks serving the Port of Oakland. Chapter 4 evaluates the effects of the fully implemented Drayage Truck Regulation on the truck fleet serving the Port of Oakland and also assesses the durability of particle filter systems as they age. Chapter 5 examines the performance of these emission control technologies under highway driving conditions at the Caldecott Tunnel, which were characterized by higher engine loads and higher truck speeds compared to the driving conditions at the Port of Oakland. Finally, Chapter 6 summarizes the main conclusions from this work and offers recommendations for future research and air pollution control policies.

Chapter 2: Methods

Reproduced in part with permission from Preble, C.V., Dallmann, T.R., Kreisberg, N.M., Hering, S.V., Harley, R.A., Kirchstetter, T.W. 2015. Effects of particle filters and selective catalytic reduction on heavy-duty diesel drayage truck emissions at the Port of Oakland. *Environ. Sci. Technol.* 49, 8864–8871. doi:10.1021/acs.est.5b01117. Copyright 2015 American Chemical Society.

2.1 Measurement Overview

To answer the research questions outlined in Chapter 1, emissions from in-use heavy-duty diesel trucks were measured at the Port of Oakland in November 2011, March 2013, and September 2015. Emissions were also measured at the Caldecott Tunnel in July–August 2014 and September–October 2015. These San Francisco Bay Area measurement sites are highlighted in Figure 2.1.

Using an instrumented van positioned above the flow of passing traffic, pollutant concentrations in the exhaust plumes of several hundred individual heavy-duty diesel trucks were directly measured with the methods summarized in Table 2.1. At the Port of Oakland, trucks passed beneath the sampling location on a major street en route to the port, where the roadway is approximately level (Figure 2.2). Port-bound trucks were either accelerating from a traffic light ~50 m before the sampling point or cruising at a speed of ~30 mph. At the Caldecott Tunnel, truck exhaust was sampled above the entrance to the southernmost bore (Bore 1), where most truck traffic traveling eastbound on Highway 24 enters the tunnel. There is a 4% uphill roadway grade at this sampling location, with trucks generally operating under heavier engine loads due to the uphill grade as well as higher vehicle speeds than were observed at the Port of Oakland.

Exhaust/ambient air mixtures sampled above the roadway were delivered to the van via a flexible aluminum duct, as shown in Figure 2.2. Gas- and particle-phase pollutant concentrations were measured at 1 Hz or faster, as specified in Table 2.1. A video camera at roadway level recorded truck license plates, which were later transcribed and matched with data in California's Drayage Truck Registry (DTR), Truck Regulation Upload, Compliance, and Reporting System (TRUCRS), and Department of Motor Vehicle (DMV) databases. Emissions were linked with specific truck details from one of these three databases on a truck-by-truck basis, including chassis model year, engine model year, and regulatory compliance status. With this linkage, it was possible to categorize individual trucks based on their installed after-treatment control technologies: (a) trucks without DPFs, (b) trucks with retrofit DPFs, (c) trucks with 2007–2009 model year engines that are equipped with a DPF at the time of manufacture, and (d) trucks with 2010 and newer engines that are equipped with both DPF and SCR emission control systems.

A sample pollutant concentration time series showing peaks associated with three trucks that drove by in rapid succession is presented in Figure 2.3. Pollutant concentration peaks were

integrated to calculate fuel-based emission factors, expressed in units of amount of pollutant emitted per kg of fuel burned, using a carbon balance method (Ban-Weiss et al., 2009):

$$E_P = \frac{\int_{t_1}^{t_2} ([P]_t - [P]_{t_1}) dt}{\int_{t_1}^{t_2} ([CO_2]_t - [CO_2]_{t_1}) dt} \frac{44}{12} w_c \quad (1)$$

The emission factor for pollutant P (E_p) is calculated over the time interval $t_1 \leq t \leq t_2$, with t_1 and t_2 determined independently by the inflection points of each concentration peak to account for the fact that instruments operated with different response times. The numerator and denominator respectively represent the baseline-subtracted peak areas for pollutant P and carbon dioxide (CO_2). When $[P]$ and $[CO_2]$ both are expressed in mass concentration units (e.g., $\mu g m^{-3}$), the ratio compares the relative abundances of pollutant P and CO_2 in the exhaust. The weight fraction of carbon in diesel fuel ($w_c = 0.87$) is used to convert the pollutant/carbon mass ratio to an emission factor expressed per unit mass of fuel burned (Ban-Weiss et al., 2009), and the factor $44/12$ converts CO_2 to carbon mass. This carbon balance method for calculating emission factors assumes that all fuel carbon is converted to CO_2 during combustion, with negligible amounts of CO and VOC emitted relative to CO_2 (Dallmann et al., 2012).

To better evaluate particle emissions, size distributions were measured in real-time with a fast mobility particle sizer (FMPS). This measurement is based on electrical mobility, in which multiple electrometers detect particles at a 1 Hz resolution. The FMPS reports PN concentrations in 32 bins between 5.6 and 560 nm. While BC and fine PM emission factors show how advanced emission control systems affect total emitted particle mass, the FMPS measurements enable an evaluation of how these technologies impact emitted particle size distributions. Given that ultrafine particles dominate particle number concentration and are associated with adverse health effects (Oberdörster, 2001; Sioutas et al., 2005; Ostro et al., 2015), it is important to consider the impact of these control systems by particle size. As such, size-resolved PN emission factors were estimated from the normalized particle size distributions measured with the FMPS:

$$\Delta E_{PN} = \frac{\Delta N}{N} E_{PN} \quad (2)$$

Particle number concentrations measured in each size bin at the leading side of the particle number concentration peak, ΔN , were baseline-subtracted and normalized to the total particle number concentration, N . The product of this normalized size distribution and the FMPS-derived PN emission factor, E_{PN} , gives the particle emission rate in each size bin in units of 10^{15} particles emitted per kg of fuel burned.

To ensure clear emission signatures that could be separated from background air pollution attributable to other sources, emission factors were only computed for trucks for which the peak CO_2 concentration rose more than 7% above baseline roadway concentrations, following Dallmann et al. (2011). The baseline was taken to be the concentration measured just prior to the passage of a truck, with the timing determined from the roadway level video. Also, emission factors were only computed when the CO_2 peak could be definitively attributed to a single truck. Thus, no plume analyses were attempted when multiple trucks drove by at the same time or in close succession. In cases where CO_2 plume capture was successful but without clearly

detectable peaks for other pollutants, near-zero values of emission factors were still computed, as illustrated in Figure 2.3.

Particle sampling configurations were designed to minimize wall losses by inertial separation and diffusion (Figure 2.4 and Figure 2.5). Laminar flow was maintained in all sampling lines to minimize particle losses due to turbulence. An in-line dilution system was used to avoid exceeding the concentration limits of the CPCs used to measure PN concentrations. This system consisted of filtered recirculating flow in a closed loop with controlled flow for a dilution ratio of 6–10, depending on the flow set point. During the Port of Oakland field measurements in 2011 and 2013, this system was actively monitored via a matched pair of standard water-based CPCs that were placed on the upstream and downstream sides of the dilutor. During the subsequent field measurement campaigns, the dilution ratio was monitored via a mass flow controller.

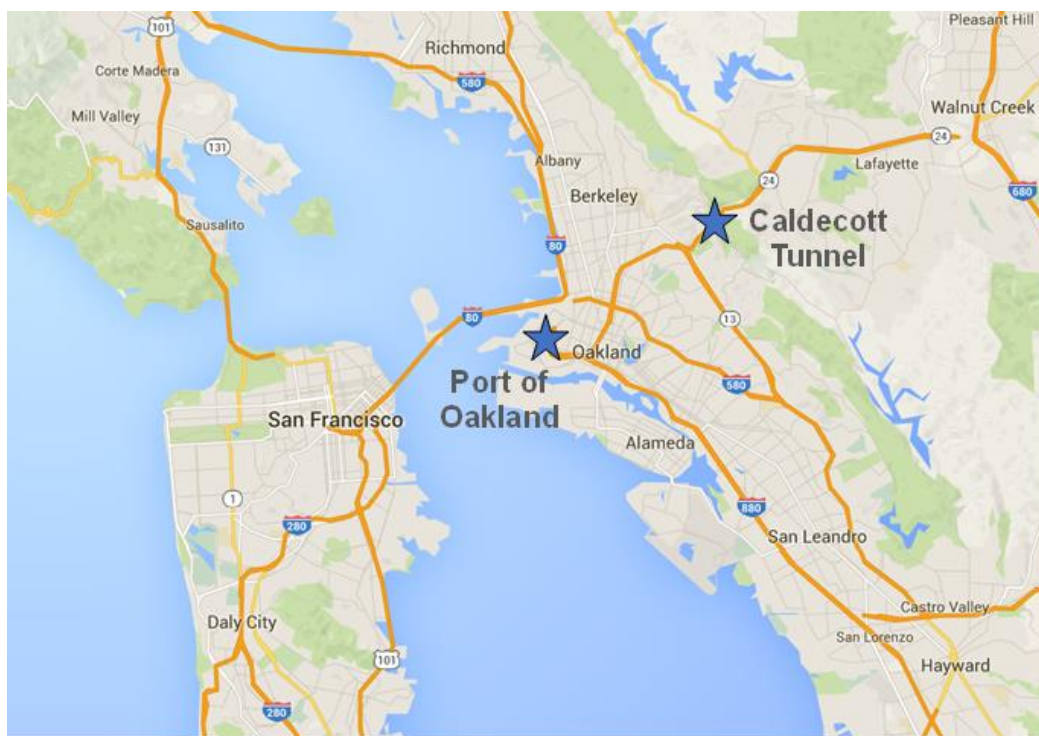

Figure 2.1 Sampling locations at the Port of Oakland and Caldecott Tunnel in the San Francisco Bay Area included in the field measurement campaigns presented here. Specifically, the sampling van is parked: (i) on the Bay Street overpass above trucks traveling westbound on 7th Street towards the Port of Oakland, and (ii) on an overpass at the CalTrans facility on the westside of the Caldecott Tunnel, above trucks traveling on Highway 24 and entering Bore 1 of the tunnel. Map is from Google.

Table 2.1 Instrumentation used to measure truck exhaust emissions in this work.

Parameter	Sampling Location/Period	Measurement Method/Analyzer	Time Resolution
CO ₂ concentration	Port (2011, 2013, 2015) Tunnel (2014, 2015)	Nondispersive infrared absorption (LI-COR LI-820 and LI-7000)	2 Hz
NO, NO _x concentrations	Port (2011, 2013, 2015) Tunnel (2014, 2015)	Chemiluminescence (Two ECO Physics CLD-64 analyzers)	2 Hz
NO ₂ concentration	Port (2015) Tunnel (2015)	Absorption spectroscopy (Aerodyne CAPS)	1 Hz
N ₂ O concentration	Port (2015) Tunnel (2014, 2015)	Cavity enhanced absorption (LGR Model 913-0015)	1 Hz
BC concentration	Port (2011, 2013, 2015) Tunnel (2014, 2015)	Aethalometer (Magee Scientific AE16)	1 Hz
BC concentration	Port (2011, 2013, 2015) Tunnel (2014, 2015)	Photoacoustic absorption spectrometer (PAS) with reciprocal nephelometer (custom)	1 Hz
PM _{2.5} concentration	Port (2011, 2013, 2015) Tunnel (2014, 2015)	Light scattering of particles (TSI DustTrak II 8530)	1 Hz
PM _{2.5} concentration	Port (2015) Tunnel (2015)	Electrical low pressure impaction (Dekati Mass Monitor)	1 Hz
PN concentration	Port (2011, 2013)	Ultrafine, water-based condensation particle counter (TSI 3788)	2 Hz
PN concentration	Port (2011, 2013, 2015) Tunnel (2014, 2015)	Ultrafine, butanol-based condensation particle counter (TSI 3776)	10 Hz
PN concentration, dilution factor	Port (2011, 2013)	Two general purpose water-based condensation particle counters (TSI 3787 and 3783)	2 Hz
PN concentration, size distribution	Port (2011, 2013) Tunnel (2014)	Fast mobility particle sizer (TSI 3091)	1 Hz



Figure 2.2 Instrumented van positioned on an overpass sampling the exhaust from a truck en route to the Port of Oakland.

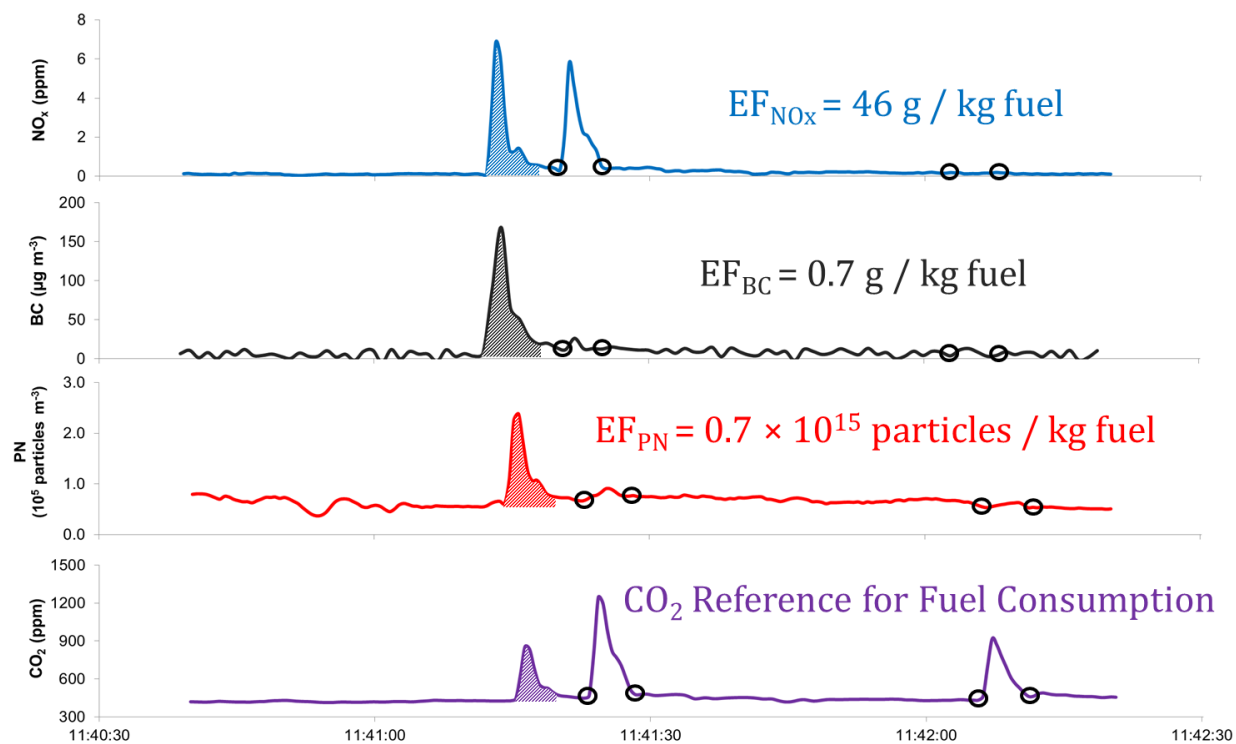

Figure 2.3 Pollutant concentration time series showing peaks that correspond to the exhaust plumes of three trucks. The first truck emitted appreciable amounts of NO_x, BC, and PN. The shaded peaks correspond to the integrated areas used to compute the emission factors shown in the figure. The second and third trucks emitted much smaller BC and PN concentrations and the third truck emitted essentially no NO_x. The integration boundaries are indicated with open circles for the second and third trucks.

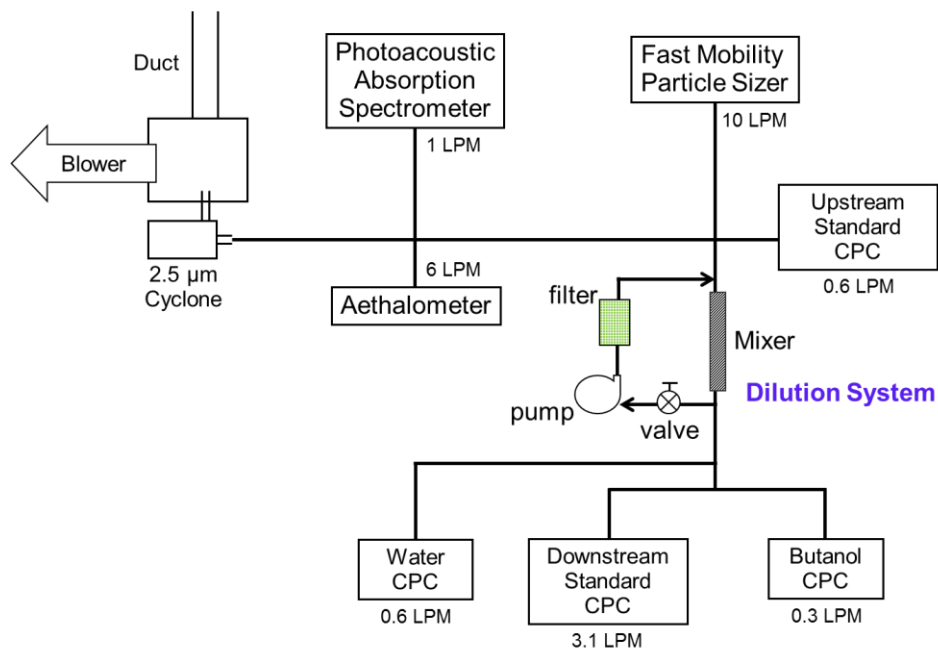

Figure 2.4 Schematic of particle sampling instruments, their flow rates, and the in-line dilution system used during the Port of Oakland field measurements in 2011 and 2013.

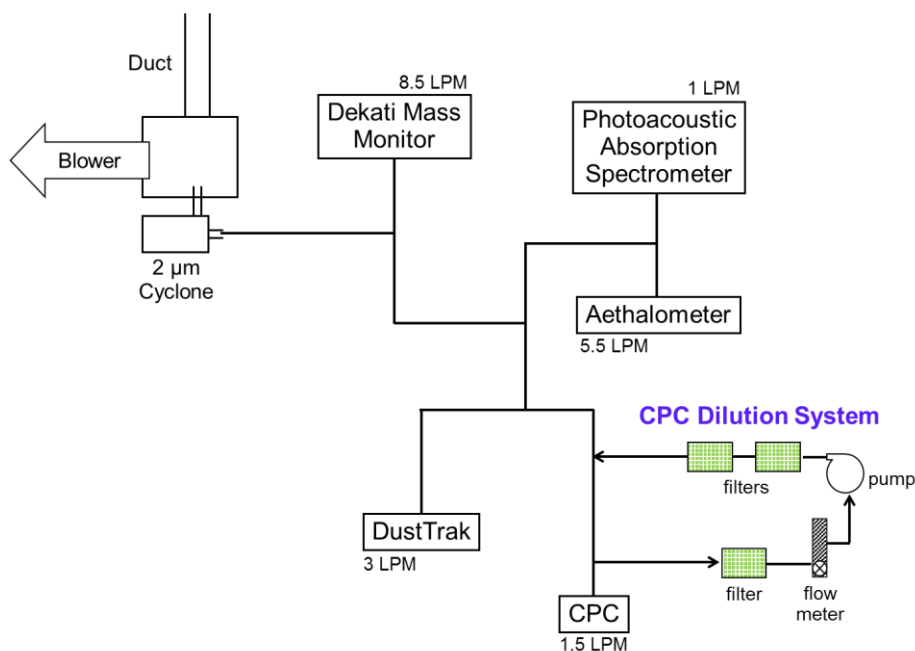

Figure 2.5 Schematic of particle sampling instruments, their flow rates, and the in-line dilution system for the condensation particle counter (CPC) that was used during the field measurement campaigns at the Port of Oakland in 2015 and at the Caldecott Tunnel in 2014 and 2015. Note, the FMPS (10 LPM) replaced the DMM in the 2014 Caldecott Tunnel setup.

2.2 Quality Assurance and Quality Control

Prior to the field studies, the analyzers and methods used were verified. All instruments and data loggers were staged in the laboratory and exposed to the exhaust of an inverted methane-air diffusion flame (Kirchstetter and Novakov, 2007). The measurement of exhaust plumes of passing trucks was simulated by episodically sampling flame exhaust instead of filtered room air. The analysis of multiple peaks under constant flame conditions was used to verify the plume capture sampling and carbon balance analysis methods used in this study. The NO₂ conversion efficiency of both chemiluminescent nitrogen oxide analyzers was evaluated using ozone titration tests to ensure accuracy of total NO_x (NO + NO₂) measurements. Multipoint calibrations were conducted for all gas analyzers. During field deployment, these calibrations were verified with zero and span checks at the beginning and end of each day of sampling. This laboratory testing also identified measurement issues with two instruments, the LI-COR model 820 CO₂ analyzer and the FMPS. A description of these issues and they were resolved is summarized below.

Laboratory testing identified a significant measurement error for the LI-COR model 820 CO₂ analyzer, which had previously been used by Dallmann et al. (2011) to measure heavy-duty diesel drayage truck emissions at the Port of Oakland. The LI-820 CO₂ analyzer was found to overshoot in reporting peak concentrations when rapid transitions occur, whereas the LI-7000 instrument did not suffer from the same problem (Figure 2.6). Therefore, the LI-7000 was used in this study for measuring CO₂ concentrations. The LI-820 CO₂ analyzer was also used in parallel during the 2011 Port of Oakland field study to assess the magnitude of possible biases in earlier measurements. Figure 2.7 shows a frequency distribution of the ratio of integrated CO₂ peaks measured using LI-820 and LI-7000 analyzers. Use of LI-820 data led to overestimates in the magnitude of CO₂ peak areas by $26 \pm 2\%$ (mean value \pm 95% confidence interval) for a sample of 389 trucks at the Port of Oakland. As such, baseline pollutant emission factors measured in the earlier field measurement campaign at the Port of Oakland in 2009 (Dallmann et al., 2011) were multiplied by 1.26 while making comparisons with emission factors measured using the more accurate LI-7000 CO₂ analyzer in the Port of Oakland campaigns presented here.

The laboratory tests also identified a concern associated with particle size distributions measured using the FMPS. Jeong and Evans (2009) previously reported an unexpected peak near the lower size limit (below 10 nm) of the FMPS when sampling ambient air in both urban and rural settings. This was posited to be due to either the data inversion algorithm or the calibration of the FMPS electrometers used for particle detection. In our tests, the FMPS overstated the concentration of UFP with diameters less than 10 nm on the trailing side of peaks when particle number concentrations were rapidly decreasing. Figure 2.8 shows an example of this effect. Accordingly, when analyzing particle size distributions measured at the Port of Oakland and Caldecott Tunnel, representative particle size distributions for each truck were chosen from the leading side of the particle number concentration peak.

An aerosol photoacoustic absorption spectrometer (PAS) was used in conjunction with an aethalometer to measure black carbon (BC) concentrations. The former instrument aided in post-processing the aethalometer data to control for the aethalometer's filter loading artifact, in which

the instrument response declines with increasing filter darkening (Kirchstetter and Novakov, 2007). A modified version of the correction equation developed by Kirchstetter and Novakov was used to adjust the BC concentration reported by the aethalometer:

$$BC = \left[\frac{BC_0}{a \exp\left(\frac{-ATN}{100}\right) + (1 - a)} \right] \quad (3)$$

where BC and BC₀ are the adjusted and unadjusted BC concentrations, respectively, and ATN is the attenuation of light by the filter. The correction parameter, *a*, adjusts BC₀ such that BC concentrations are independent of filter loading. This correction is validated by plotting the ratio of the light absorption coefficient measured with the photoacoustic absorption spectrometer (PAS) and the BC concentration measured with the aethalometer, as shown in Figure 2.9. Both instruments respond to light-absorbing PM, but the in-situ PAS measurement is not affected by filter loading effects. As shown, the ratio of absorption coefficient to BC₀ increased from zero to a factor of two as the aethalometer filter progressed from pristine (ATN = 0) to heavily loaded (ATN = 150). In contrast, the ratio of absorption coefficient to BC is approximately constant and independent of ATN. This indicates that adjusted BC concentrations can be up to two times higher than unadjusted BC concentrations, assuming aethalometer measurements as the basis.

The measurements of diesel truck exhaust at the Port of Oakland indicated *a* = 0.66, whereas BC emission factors reported by Dallmann et al. (2011) were corrected with Kirchstetter and Novakov's value of *a* = 0.88 (Kirchstetter and Novakov, 2007). This published value was derived from testing using laboratory-generated soot, while the current value is site-specific. A site-specific value of *a* = 0.73 for diesel truck exhaust at the Caldecott Tunnel had been previously established (Dallmann et al., 2012) and was used in the measurements presented here. Based on calculated BC emission factors using both values for 1000 individual trucks at the Port of Oakland, emission factors calculated with *a* = 0.66 were 15 ± 2% lower on average than those calculated using *a* = 0.88. Therefore, BC emission factors measured in the 2009 campaign (Dallmann et al., 2011) were multiplied by 0.85 (i.e., total correction with CO₂ = 1.07) before making comparisons to emission factors derived from field campaigns presented here. No adjustment was required for the previously measured BC emission factors at Caldecott Tunnel in 2010, as the site-specific value of *a* = 0.73 was also used in the measurement campaigns presented here.

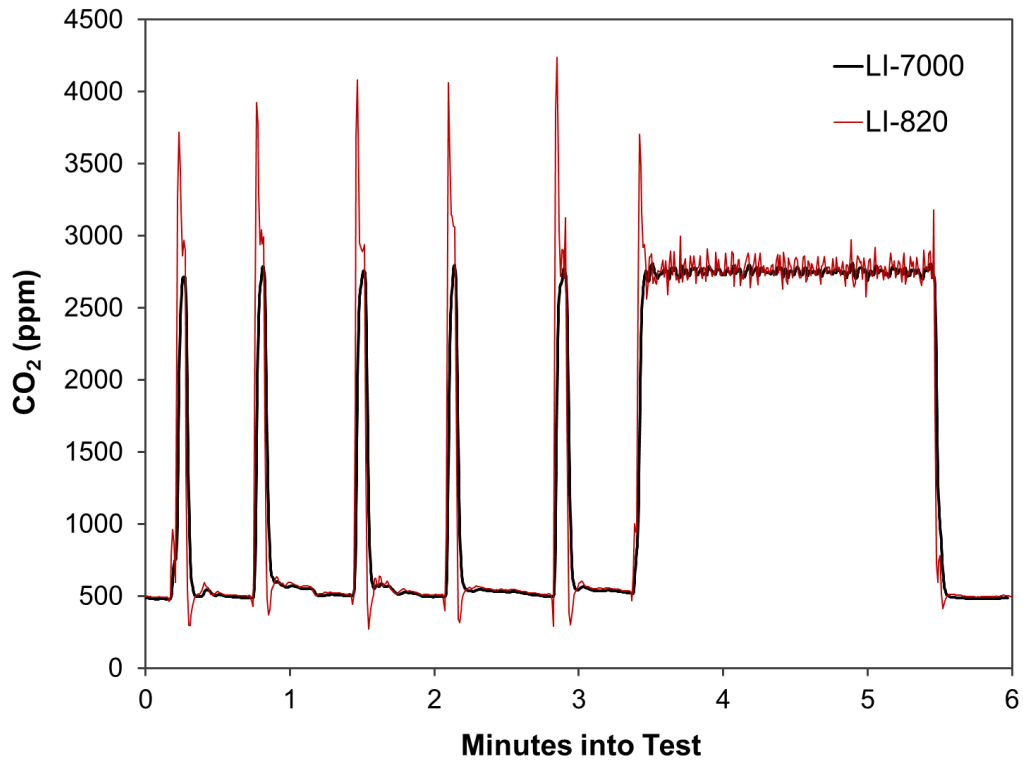

Figure 2.6 Comparison of time series of CO₂ concentrations measured in laboratory evaluation of two LI-COR CO₂ analyzers: LI-820 and LI-7000. The LI-820 overshoots when concentrations change rapidly, whereas the higher performance LI-7000 transitions smoothly to match new peak concentrations.

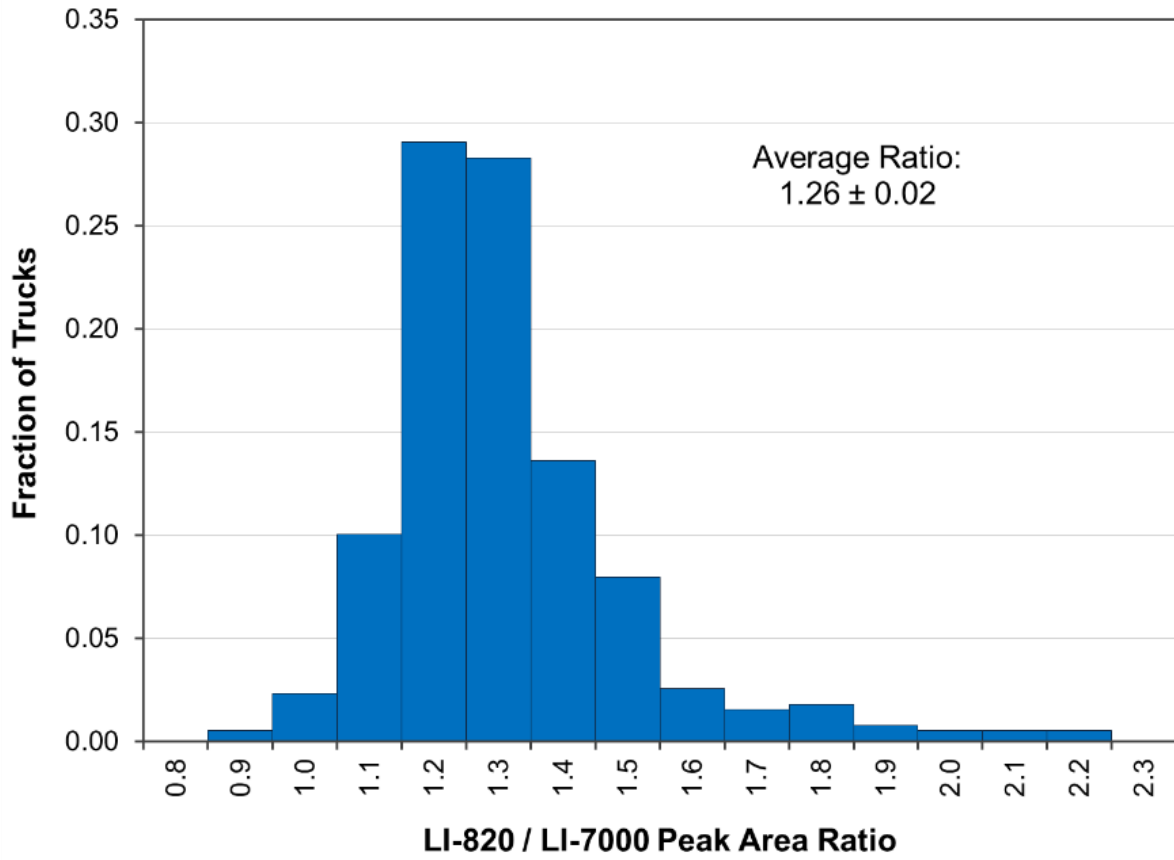

Figure 2.7 Distribution of average ratio of CO₂ peak areas measured by LI-820 and LI-7000 analyzers, as determined from concurrent measurements during the 2011 study at the Port of Oakland.

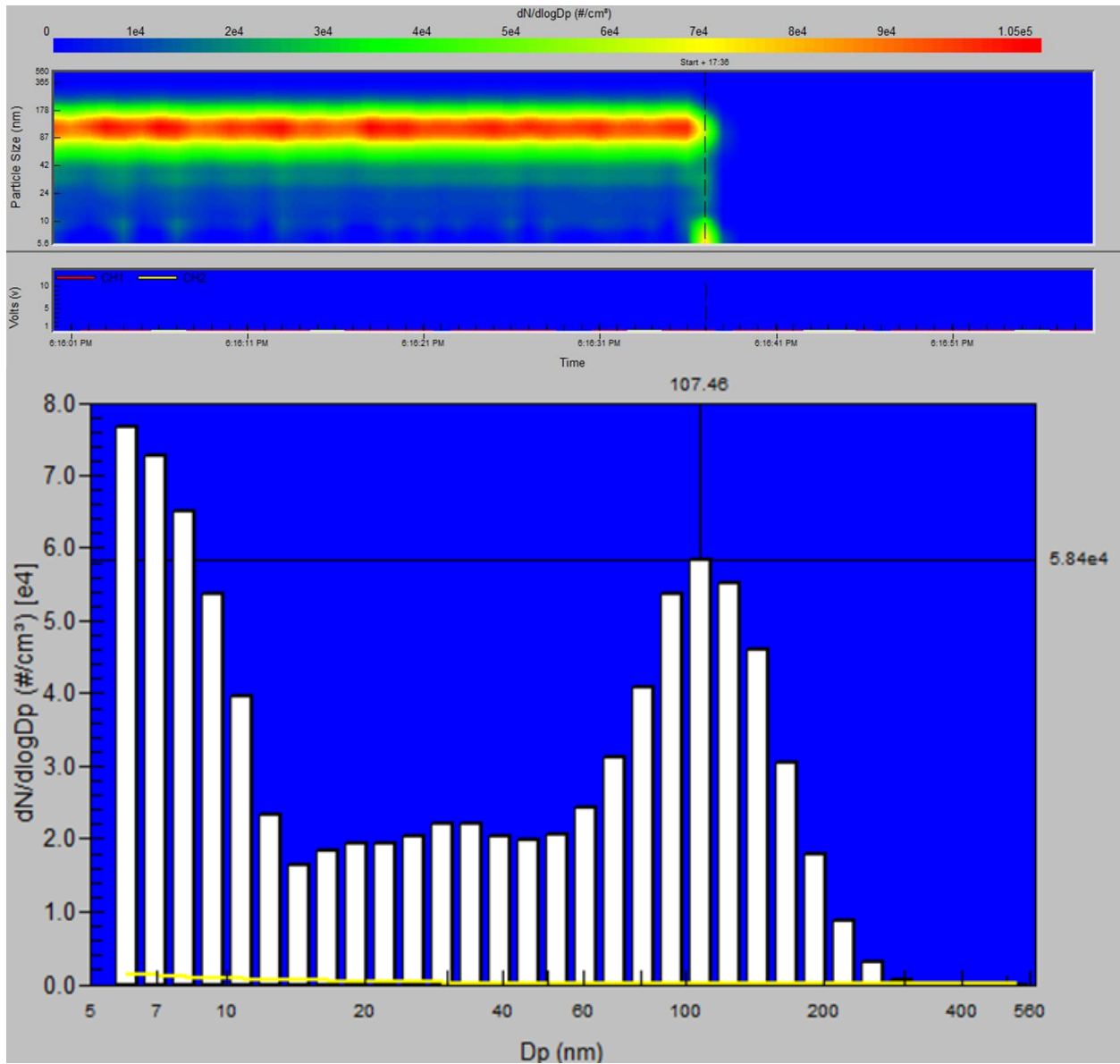

Figure 2.8 FMPS data showing an example of the artificial increase in UFP number concentration of particles below 10 nm in diameter when particle number concentrations were rapidly decreasing. The top panel shows the measured particle number concentration, sampled from a constant source in the laboratory. The vertical dashed line shows the time at which the number concentration decreased and the artificial pulse of particles <10 nm was reported. The bottom panel shows the corresponding particle size distribution at that time, including an anomalous peak in particle sizes below 10 nm.

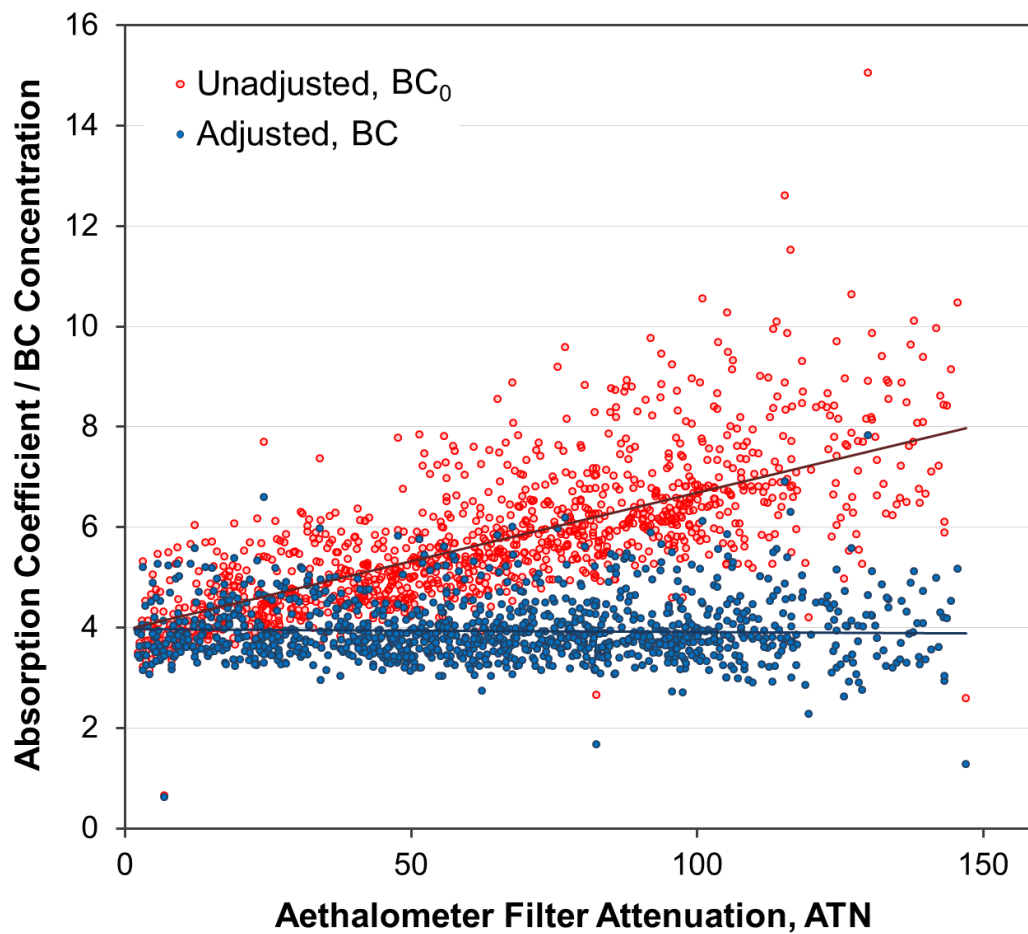

Figure 2.9 BC concentration measured using an aethalometer and absorption coefficient measured using a photoacoustic absorption spectrometer (PAS). Unadjusted BC concentrations (BC_0) depend on aethalometer filter loading (i.e., ATN) whereas the adjusted BC concentrations (BC) are independent of ATN.

2.3 Measurement Method Comparisons

The suite of analyzers used in these field studies included multiple measurements of the same pollutant species, including PN, NO₂, and fine PM. This duplication offered an opportunity to compare the response of instruments based on different measurement techniques.

The 2011 and 2013 measurements at the Port of Oakland included multiple measures of PN, including water- and butanol-based ultrafine CPCs and the FMPS. As presented in Figure 2.10, results from the water CPC were highly correlated ($R^2 = 0.9$) but 30% higher, on average, than PN emission factors for the same trucks calculated from measurements made using a butanol CPC. This difference could be due to CPC sensitivity to particle composition that depends on the condensing fluid (i.e., water versus butanol), or due to other differences in CPC design (Franklin et al., 2010). PN emission factors derived from water CPC and FMPS measurements were not as well correlated ($R^2 = 0.5$). On average, emission factors based on the water CPC were about 2 times higher than those based on the FMPS. The lower values derived from FMPS measurements may in part be because the ultrafine CPC measures particles as small as 2.5 nm, whereas the low cutoff of the FMPS is 5.6 nm. This finding agrees with Jeong and Evans (2009), who noted that ultrafine water-based CPC measurements of PN concentration exceed FMPS measurements. In contrast, Zimmerman et al. (2014) found that the FMPS can overstate PN concentrations when measuring emissions from high-emitting vehicles at high time resolution.

The 2015 measurements at both locations included duplicate measures of NO₂ and fine particle mass (PM). Figure 2.11 through Figure 2.13 show comparisons between these measurement methods. NO₂ concentrations were measured *by difference* via two chemiluminescent analyzers with one monitor measuring total NO_x and the other measuring NO, as well as *directly* with a monitor that used a cavity-attenuation phase shift technique (Kebabian et al., 2008). Overall, these two measurements of NO₂ were highly correlated ($R^2 = 0.93$) with a slope near unity and near-zero intercept (Figure 2.11).

Fine PM concentrations were measured with a DustTrak and a Dekati Mass Monitor (DMM). The DustTrak uses light scattering to infer particle mass concentrations. This method requires calibration to control for differences in aerosol optical properties. The factory setting assumes that the aerosol being measured is Arizona road dust, which is coarser and gives a higher fraction of scattered light compared to the darker and strongly-absorbing particles emitted in heavy-duty diesel engine exhaust. Calibrating the DustTrak specifically to the truck exhaust sampled at the Port of Oakland and Caldecott Tunnel was not possible, as the particle mass collected on filters during plume sampling was insufficient to create a complete calibration curve for the analyzer. These measurements are still qualitatively useful, but they may not accurately represent fine PM emission rates. The DMM uses electrical low-pressure impaction to determine concentrations of fine PM, and thus should not require aerosol-specific calibration. The agreement between these two measures was strong when derived emission factors were less than 5 g kg⁻¹ ($R^2 = 0.83$), but the agreement became weaker when larger emission factors were included in the analysis ($R^2 = 0.65$), as shown in Figure 2.12. Fine PM emission factors determined with the DMM tended to be smaller than those calculated from the DustTrak measurements. This disparity may be due to the difference in measurement method between the two analyzers. There is also a difference in

the particle size-selective inlets for these two analyzers. The DustTrak measured PM_2 , as larger particles were excluded using a cyclone located upstream at the beginning of the aerosol sampling line (Figure 2.5). The DMM included an internal cyclone and provides mass data for $PM_{1.2}$. The difference in particle mass between these two cut points is likely to be small in this study, though, as diesel exhaust PM emissions consist almost entirely of sub-micron particles (see Chapter 3). Overall, the DMM-derived fine PM emission factors correlated better with the corresponding BC emission factors than the DustTrak-derived values (Figure 2.13). However, fine PM emission factors derived from both analyzers can be smaller than the corresponding BC emission factors (Figure 2.13). Since BC is a component of PM, the PM reading should be at least as large as BC, and caution is therefore needed in comparing absolute values of fine PM and BC emission rates reported here.

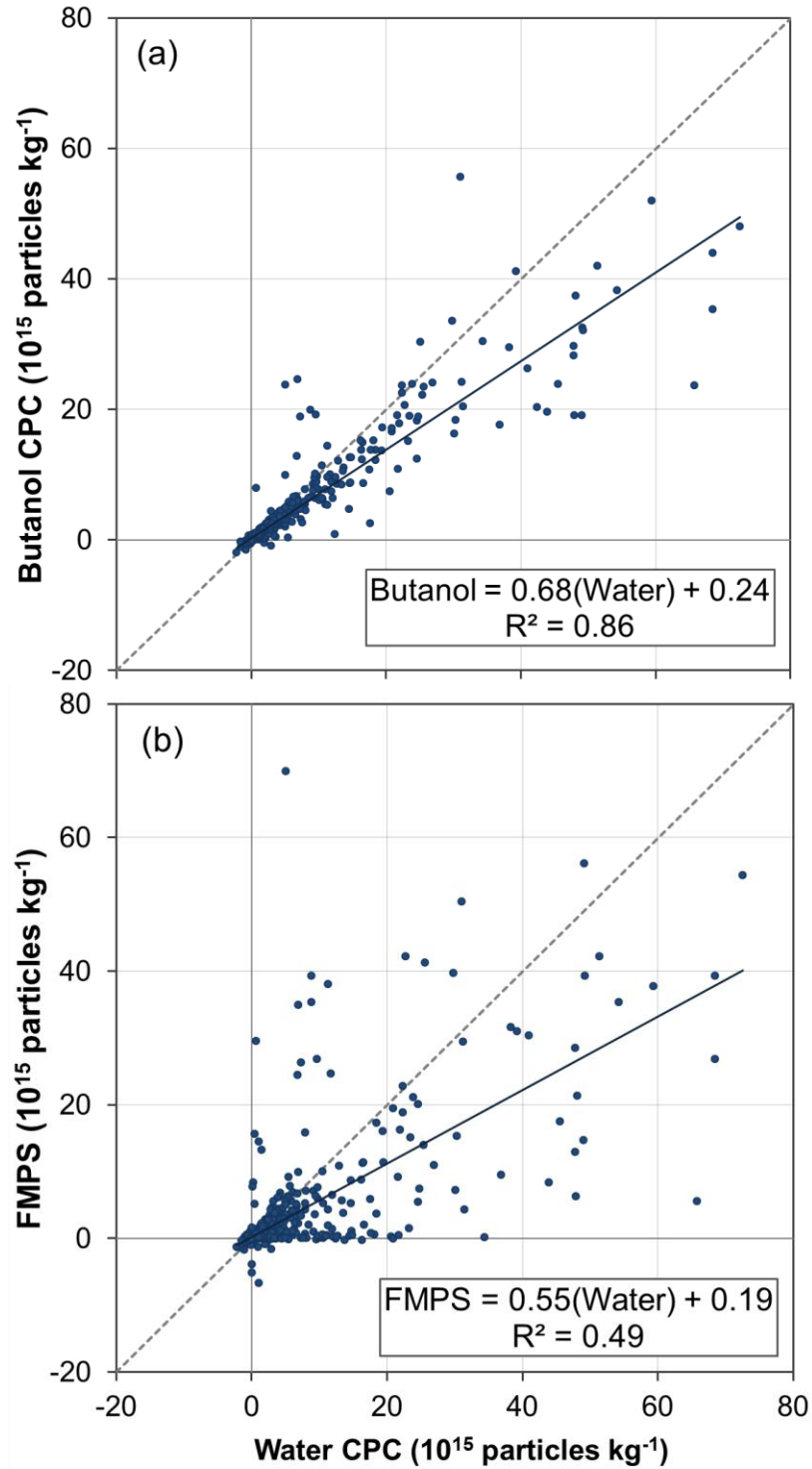

Figure 2.10 Comparison of PN emission factors determined from the ultrafine water- and butanol-based CPCs and the FMPS. The dashed line is the 1:1 diagonal; linear best fit lines and regression statistics are also shown for each plot.

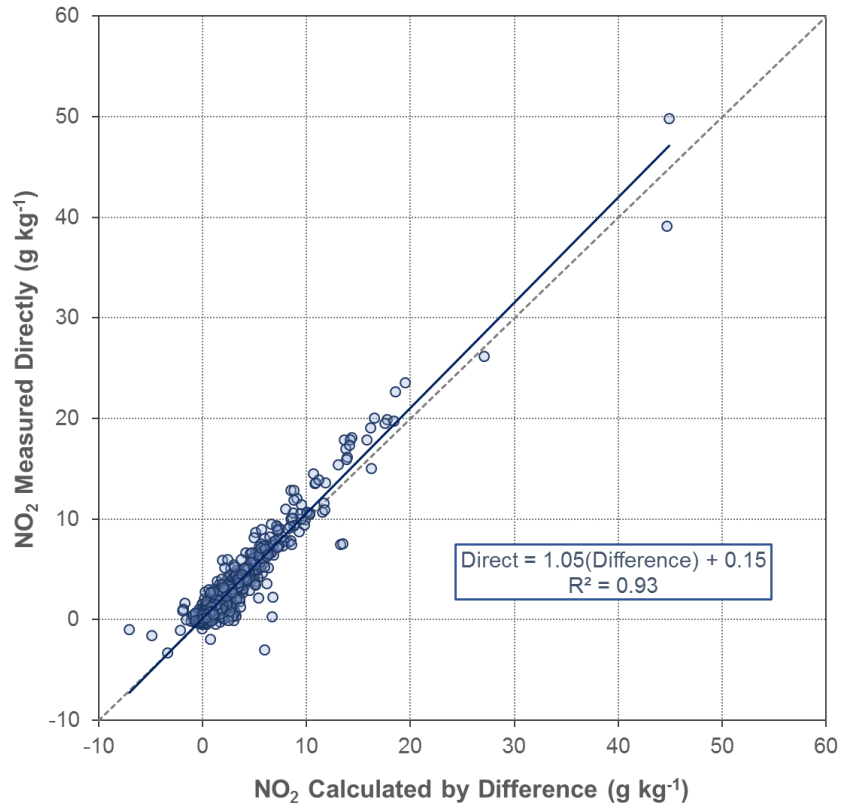

Figure 2.11 Nitrogen dioxide (NO₂) emission factors determined by difference with two chemiluminescent analyzers versus directly by absorption for individual heavy-duty diesel trucks at the Port of Oakland in 2015.

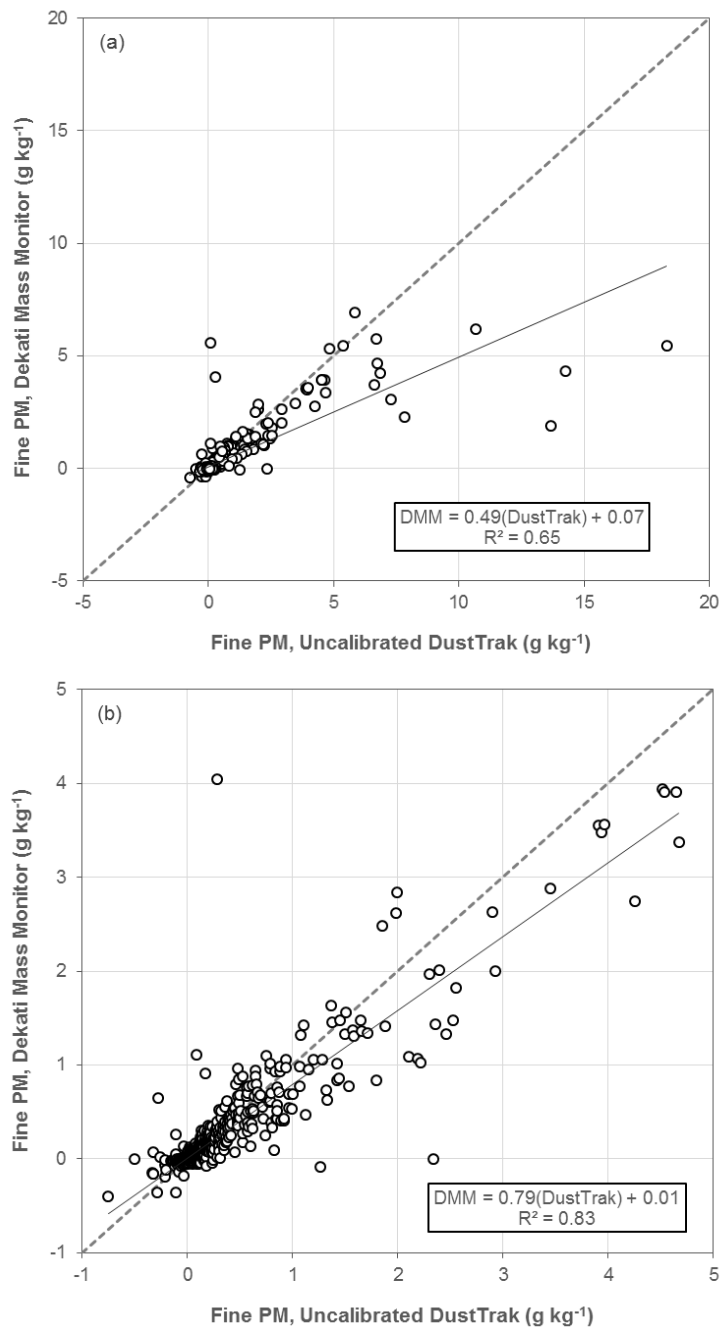

Figure 2.12 Fine particle mass (PM) emission factors determined with a DustTrak versus a Dekati Mass Monitor (DMM) at the Port of Oakland in 2015. The same data is shown in both (a) and (b), but the regression of (a) includes all data whereas the linear regression for (b) isolates data where BC emission factors are $< 5 \text{ g kg}^{-1}$. Note that the DustTrak measurement was not calibrated to heavy-duty diesel truck exhaust. Also, the DustTrak measured PM_2 while the DMM measured $\text{PM}_{1,2}$.

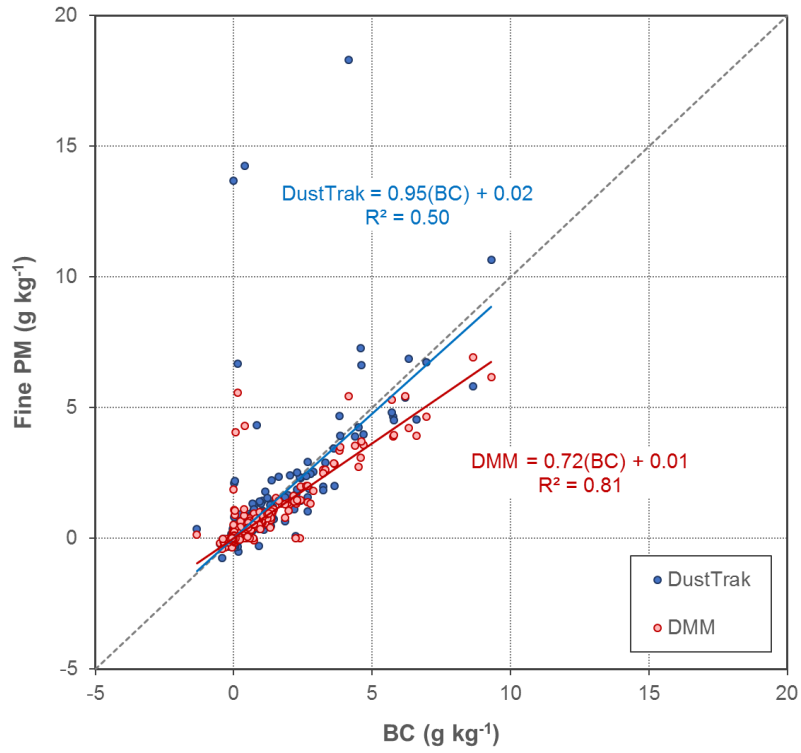

Figure 2.13 Fine particle mass (PM) emission factors determined with a DustTrak and a Dekati Mass Monitor (DMM) versus corresponding black carbon (BC) emission factors found for individual heavy-duty diesel trucks sampled at the Port of Oakland in 2015.

Chapter 3: Effects of DPFs and SCR on Drayage Truck Emissions

Reproduced in part with permission from Preble, C.V., Dallmann, T.R., Kreisberg, N.M., Hering, S.V., Harley, R.A., Kirchstetter, T.W. 2015. Effects of particle filters and selective catalytic reduction on heavy-duty diesel drayage truck emissions at the Port of Oakland. *Environ. Sci. Technol.* 49, 8864–8871. doi:10.1021/acs.est.5b01117. Copyright 2015 American Chemical Society.

3.1 Introduction

This chapter evaluates the effects of diesel particle filters (DPFs) and selective catalytic reduction (SCR) systems on the Port of Oakland drayage truck fleet. The emission impacts of these technologies were measured during the first phase of the Drayage Truck Regulation. Over this first phase, all drayage trucks operating at freight-handling facilities like ports and railyards were required to be equipped with DPFs, either via retrofit or engine replacement, as summarized in Table 1.2.

Emissions from California drayage trucks have been previously evaluated as fleet modernization programs have been implemented (Dallmann et al., 2011; Bishop et al., 2012, 2013, 2015). At the Ports of Los Angeles and Long Beach in Southern California, the drayage fleet was almost entirely replaced with new trucks, so the mean age of trucks decreased from 12.7 years to 2.5 years between 2008 and 2010 (Bishop et al., 2012). Associated emissions reductions observed for carbon monoxide, NO_x, and exhaust opacity were 30, 48, and 54%, respectively (Bishop et al., 2012). In contrast to the Southern California ports where truck replacement predominated, there was significant retrofitting of DPFs on older drayage trucks at the Port of Oakland. Dallmann et al. (2011) reported a 41% reduction in NO_x and a 54% reduction in BC emissions between 2009 and 2010 after pre-1994 trucks were banned and trucks with 1994–2003 engines were either retrofit or replaced with newer equipment. The BC reductions resulted primarily from increased use of DPFs, whereas NO_x reductions were attributed to fleet modernization, as the newer engines met more stringent NO_x emission standards. The initial round of changes to the drayage truck fleet at the Port of Oakland led to an increased proportion of trucks with 2004 and newer engines, as well as a reduction in mean engine age from 11.0 to 8.3 years (Dallmann et al., 2011).

The current study builds on previous work at the Port of Oakland and features new field measurements including additional pollutants not previously measured, namely nitrogen dioxide (NO₂), particle number (PN), and particle size distributions. Also, emission factors for individual trucks in the current study were linked to engine attributes through transcribed license plate data, as described in Chapter 2. This linkage makes it possible to compare emissions across different control technology groups, in addition to quantifying changes in fleet-average emission factors over time.

3.2 Results and Discussion

3.2.1 Accelerated Adoption of Emission Control Systems at the Port of Oakland

Driven by the Statewide Drayage Truck Regulation, use of DPFs and SCR systems by the Port of Oakland drayage truck fleet increased between 2009 and 2013. Table 3.1 summarizes the evolution of the port fleet as it rapidly adopted these emission control technologies. Note that information about the 2008 fleet is based on a local truck survey (BAAQMD, 2009) rather than our own field surveys. However, this distribution is assumed to represent the age distribution of drayage trucks operating at the Port prior to the regulatory changes.

Over the span of a few short years, adoption of DPFs—either via retrofit or as original equipment—by the drayage truck fleet became near-universal and SCR was also present on 10% of the truck fleet. This accelerated introduction of these emission control technologies thereby offers a unique opportunity to evaluate performance under on-road driving conditions rather than relying on laboratory-based dynamometer testing that employs simulated driving cycles.

Table 3.1 Composition of the Port of Oakland’s drayage truck fleet by emission system control category over time, with adoption of these technologies accelerated by the Drayage Truck Regulation (see Table 1.2 for implementation schedule).

Calendar Year	Range of Engine Model Years	No DPF (pre-2007 engines)	Retrofit DPF (1994–2006 engines)	DPF (2007–2009 engines)	DPF + SCR (2010+ engines)
2008* (2% DPF, 0% SCR)	1970–2009 (N = 1817)	98% (n = 1777)	0% (n = 0)	2% (n = 40)	0% (n = 0)
2011 (54% DPF, 2% SCR)	1994–2011 (N = 381)	46% (n = 174)	33% (n = 126)	20% (n = 75)	2% (n = 6)
2013 (99% DPF, 9% SCR)	1992–2013 (N = 1016)	1% (n = 15)	28% (n = 281)	62% (n = 626)	9% (n = 94)

*2008 fleet information based on a survey of chassis not engine model year (BAAQMD, 2009); truck chassis is typically one year older than engine model year.

3.2.2 DPF and SCR Impacts on Average Emission Rates

Table 3.2 reports emission factors from the 2011 and 2013 field measurement studies that were together disaggregated into four truck categories based on engine model year and installed emission controls: (1) 1994–2006 engines with retrofit DPFs, (2) 2004–2006 engines without DPFs, (3) 2007–2009 engines with DPFs, and (4) 2010–2013 engines with DPFs and SCR. Unless explicitly labeled as a retrofit, DPF and SCR controls were installed as original equipment at the time of manufacture. In Table 3.2 and elsewhere, uncertainty ranges represent 95% confidence intervals and model years refer to the engine, which is the basis on which emission standards and retrofit requirements were specified, rather than the year of the truck chassis.

Trucks equipped with SCR systems emitted on average a factor of $80 \pm 8\%$ less total NO_x than trucks with 1994–2003 model year engines, $69 \pm 15\%$ less NO_x than 2004–2006 engines, and $57 \pm 14\%$ less NO_x than 2007–2009 engines (Table 3.2). These differences are not a function of whether or not these pre-2010 model year engines are equipped with DPFs, but instead are due to the increasingly stringent NO_x emission limits shown in Figure 1.1. The emission rate of tailpipe NO_2 , on the other hand, is mainly determined by engine model year and the presence of a DPF. Older engines equipped with retrofit DPFs emit up to seven times more NO_2 than modern engines without filters (Table 3.2). NO_2/NO_x emission ratios were highest for newer trucks with DPFs, with or without SCR systems, but engines with SCR had lower absolute NO_2 and NO_x emission rates (Table 3.2). The NO_2 emission rate for trucks with SCR systems was the lowest of the DPF-equipped trucks, although the emission rate was still twice that of modern trucks without filters. As such, SCR plays an important role in partially mitigating the undesired increase in primary NO_2 emissions associated with the use of DPFs to control exhaust PM emissions.

BC emission factors for older trucks with retrofit DPFs and 2007–2009 trucks originally equipped with DPFs were similar (Table 3.2). The newest trucks with 2010+ engines equipped with both DPFs and SCR had the lowest BC emission factors. Relative to modern trucks (2004–2006 engines) without these emission controls, trucks with pre-2010 engines equipped with DPFs emitted $74 \pm 30\%$ less BC. The newest trucks (2010+ engines) emitted $92 \pm 32\%$ less BC than the 2004–2006 trucks, which is consistent with prior laboratory studies of DPF effectiveness (Biswas et al., 2008; Herner et al., 2009; Barone et al., 2010).

Under the driving conditions at this location, DPFs do not increase average PN emission rates. In fact, particle filters reduced the average PN emission rate by these drayage trucks. The PN emission rates for older trucks equipped with retrofit DPFs and 2007–2009 engines with original equipment DPFs were approximately half that of modern engines without filters. 2010+ engines had the lowest PN emission rates, emitting about one-third the number of particles per kg of fuel burned compared to trucks without DPFs (Table 3.2). These trends are counter to the previously discussed dynamometer test-based concern that DPF-controlled reductions in emitted particle mass could promote nucleation of ultrafine particles (UFP) and increase PN emissions (Kittelson, 1998; Biswas et al., 2008; Herner et al., 2011).

Emission factor-weighted particle size distributions were used to derive a characteristic particle number emission profile for each truck category. Measured size distributions for each truck were weighted by corresponding FMPS-derived PN emission factors. As shown in Figure 3.1, particle emissions ranging in size between 5.6 and ~300 nm were measured, with a majority occurring in the ultrafine mode below 100 nm.

Figure 3.1 shows that the average size distribution for trucks without DPFs was trimodal, including broad peaks around 10, 20, and 80 nm. Overall, DPFs appear to be most effective in reducing the emission rate of particles larger than ~15 nm. On average, the emission rates of such particles from trucks without filters were approximately 3.5 times those from DPF-equipped trucks. These results further indicate that use of DPFs on drayage trucks for controlling particle mass does not increase the emission factor of nucleation mode particles, which was a potential concern raised in other studies (Biswas et al., 2008; Herner et al., 2011). DPFs on trucks with 2007 and newer engines typically include active filter regeneration systems (e.g., periodic injection of unburned fuel to oxidize trapped particles). Nucleation is likely to occur during such active regeneration events (Herner et al., 2011), with increased emissions of <30 nm particles (Quiros et al., 2014). In this study, the emission factor of ~10 nm particles from 2007–2009 DPF-equipped engines was 2.5 times the levels measured from both older truck engines with retrofit DPFs and 2010+ engines equipped with DPFs and SCR. Particle size distributions for all four groupings of trucks include an apparent sharp increase in the smallest size bin of the FMPS. This data is presented as measured, though it is unclear if they are truly indicative of a peak in the number concentration of particles smaller than the lower sizing limit of the FMPS.

The size-resolved FMPS particle count data was also used to estimate size-resolved mass emissions. Assuming spherical particles with a density of 1 g cm^{-3} across the entire particle size range, PN distributions were converted into mass emission distributions. The PM emission factor for each truck category could ideally be estimated from the integrated area under each respective mass emission rate distribution. However, low number concentrations in the larger size ranges that were near or below the FMPS detection limit result in noise in the upper size bins that is magnified when number concentrations are converted to mass concentrations, as seen in Figure 3.1. Therefore, PM emission factors corresponding to each truck category were determined assuming lognormal distributions and doubling the area to the left of the apparent peak value of each mass emission rate distribution. This peak in the mass emission distribution was typically around 200 nm. Recent studies indicate that additional particle mass exists beyond the upper size limit of the FMPS for diesel exhaust (Liu et al., 2012; Quiros et al., 2015). Therefore, the PM emission factors derived from FMPS measurements and reported in Figure 3.1 may understate the true PM emission rates. The estimated PM emission factor for 2010+ engines equipped with both DPFs and SCR was ~86% lower than that found for 2004–2006 engines without these emission controls. This decrease in PM emissions is slightly smaller than the 92% decrease found for BC (Table 3.2). Similarly, the average reduction in estimated PM emission factor for all DPF-equipped trucks compared to trucks without filters (~72%) was slightly lower than that found for BC (80%).

As shown in Figure 3.2, the highest emitters of BC generally tended to have low emissions of PN and NO₂—and vice versa—regardless of the type or vintage of emission control equipment. Such a relationship between BC and PN has been observed previously (Ban-Weiss et al., 2009). This result is consistent with the hypothesis that UFP formation is suppressed when large amounts of particle surface area are available, such that condensation onto existing particle surfaces is favored over nucleation to form UFP (Kittelson, 1998). Likewise, the relationship between BC and NO₂ has been reported previously (Dallmann et al., 2012), and is the expected result of well-functioning DPF systems, which reduce BC mass emissions while deliberately oxidizing NO to NO₂ to aid in filter regeneration.

Table 3.2 Average emission factors (\pm 95% confidence interval) for heavy-duty drayage trucks characterized by engine control technology and engine model year. Results are based on combined data from the 2011 and 2013 field measurements at the Port of Oakland.

Emissions Control Category	Range of Engine Model Years	Median Engine Model Year	Number of Trucks^a	NO_x (g kg⁻¹)	NO₂ (g kg⁻¹)	NO₂/NO_x Emission Ratio	BC (g kg⁻¹)	PN^b (10¹⁵ particles kg⁻¹)
No DPF	2004–2006	2005	178–188	16.5 \pm 1.7	0.56 \pm 0.28	0.034 \pm 0.018	1.11 \pm 0.26	3.87 \pm 0.80
Retrofit DPF	1994–2006	1998	390–401	26.0 \pm 1.3	3.91 \pm 0.38	0.150 \pm 0.017	0.32 \pm 0.06	1.79 \pm 0.50
DPF	2007–2009	2008	657–695	11.9 \pm 0.9	2.68 \pm 0.27	0.225 \pm 0.029	0.26 \pm 0.06	2.01 \pm 0.47
DPF + SCR	2010–2013	2011	93–99	5.1 \pm 1.2	1.14 \pm 0.27	0.221 \pm 0.084	0.09 \pm 0.04	1.05 \pm 0.60

^aThe number of trucks used for each category analysis depended on the data available from each instrument; the maximum number in the given range corresponds to NO_x, NO₂, and NO₂/NO_x calculations and the minimum number typically refers to PN. The sample size for BC analysis generally falls in the middle of the range.

^bReported PN emission factors were determined from the butanol-based ultrafine condensation particle counter.

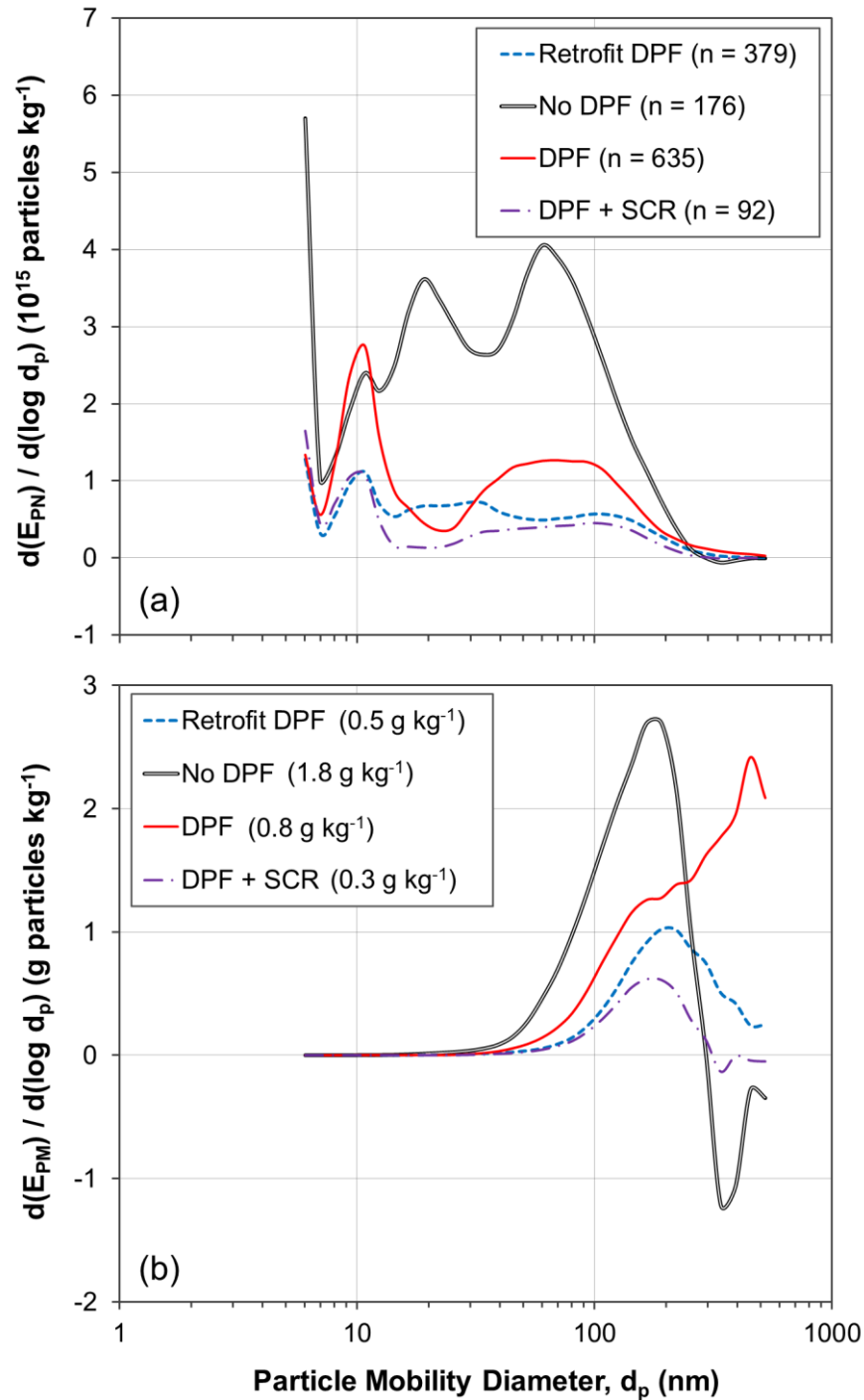

Figure 3.1 Characteristic particle (a) number and (b) mass emission rate distributions for each emission control technology, based on combined 2011 and 2013 data. The particle mass emission factor estimated from each size distribution is noted in the figure legend. Note that data above ~ 200 nm in (b) are not reliable, given low particle number concentrations in this size range as shown in (a).

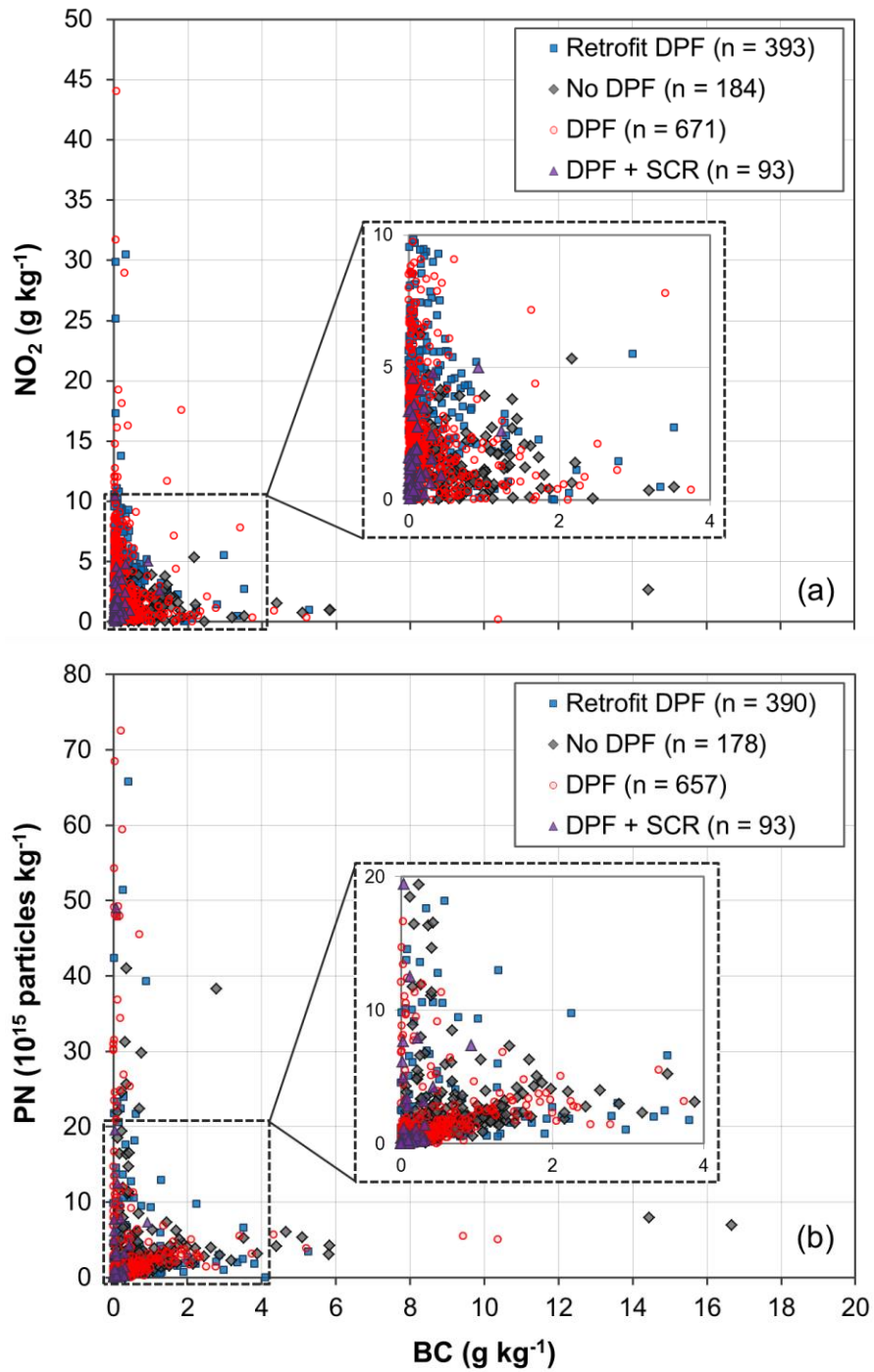

Figure 3.2 Relationship between emissions of BC to emissions of (a) NO_2 and (b) PN by truck category. The highest emitters of BC tend to have low emissions of PN and NO_2 , and vice versa, across engine model years and installed control technologies.

3.2.3 Emission Factor Distributions

As an increasing proportion of drayage trucks were equipped with DPF and SCR systems, emission factor distributions of BC and NO_x became increasingly skewed, such that a small fraction of the fleet was responsible for an increasing fraction of total emissions (Figure 3.3). This increasing skewness of emission factor distributions over time also occurs as a result of natural fleet turnover, in which newer trucks that meet more stringent emission standards replace older engines. As more of the fleet is renewed and transitions to associated lower emission rates, the overall fleet total emissions become increasingly dominated by a smaller fraction of high-emitting trucks. In this study, as more trucks equipped with DPF and SCR systems for PM and NO_x control entered into service at the Port of Oakland, the contributions of high-emitting trucks to overall fleet emissions became increasingly dominant (Figure 3.3).

As shown in Figure 3.3 and Figure 3.4, particle-related emission factor distributions are more skewed than those for nitrogen oxides. In 2013, when 99% of trucks had adopted DPFs and 9% were also equipped with SCR, the highest emitting 10% of trucks were responsible for 65% of total BC and 80% of total PN, compared to only 32% of total NO_x emissions (Figure 3.4). The skewness of NO_x emission factor distributions has increased, though, and this trend is likely to continue as the number of engines equipped with SCR increases in future years (Figure 3.3).

Emission factor distributions are shown separately for each engine model year, as measured in 2011 and 2013, in Figure 3.5 and Figure 3.6. Trucks equipped with DPF and SCR systems not only had the lowest BC and NO_x emission factors, but also showed the least amount of variability in measured emission rates. The upper range of measured emission rates for many individual engine model years increased in 2013 relative to 2011, suggesting possible degradation or failure of some installed emission control systems over time. This potential issue of aging DPF deterioration is explored in greater detail in Chapter 4.

Figure 3.5 identified two DPF-equipped trucks as the highest BC emitters in 2013. These trucks had emission factors of ~10 g BC kg⁻¹, significantly higher than the category-average of 0.26 ± 0.06 g kg⁻¹ and approximately double the emission rate of next highest-emitting truck. These two high-emitting trucks represented 0.2% of the total number of trucks measured, but were responsible for 7% of total BC emissions (Figure 3.4). This analysis also shows that trucks with 2007–2009 engines frequently emit NO_x at levels that are similar to what is observed from older trucks, even though the average emission rate for older trucks is approximately twice as high (Table 3.2 and Figure 3.6). In summary, even though average emissions of BC and NO_x have decreased, some newer trucks were observed to emit BC and NO_x at high levels.

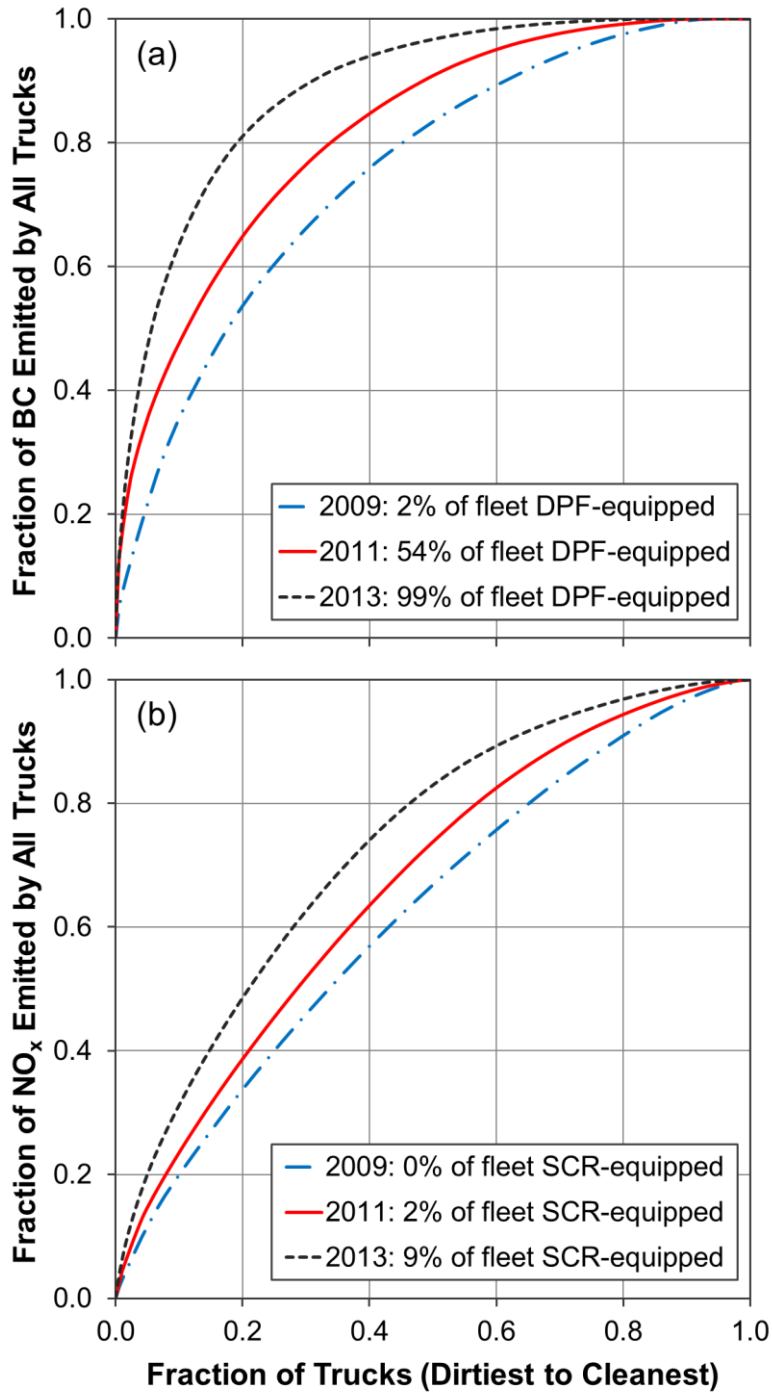

Figure 3.3 Cumulative emission factor distributions for (a) BC and (b) NO_x over time as a greater fraction of the Port of Oakland drayage truck fleet adopted DPF and SCR systems. In these distributions, trucks are ranked from highest to lowest in terms of emission factors.

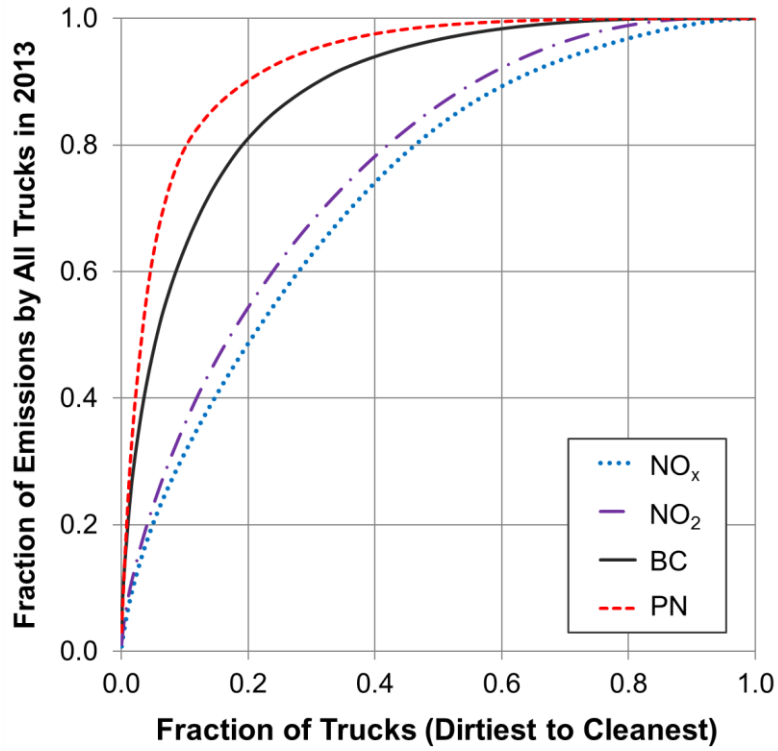

Figure 3.4 Cumulative emissions of NO_x, NO₂, BC, and PN as measured for the 2013 drayage truck fleet at the Port of Oakland, which was comprised of 99% DPF-equipped and 9% SCR-equipped trucks.

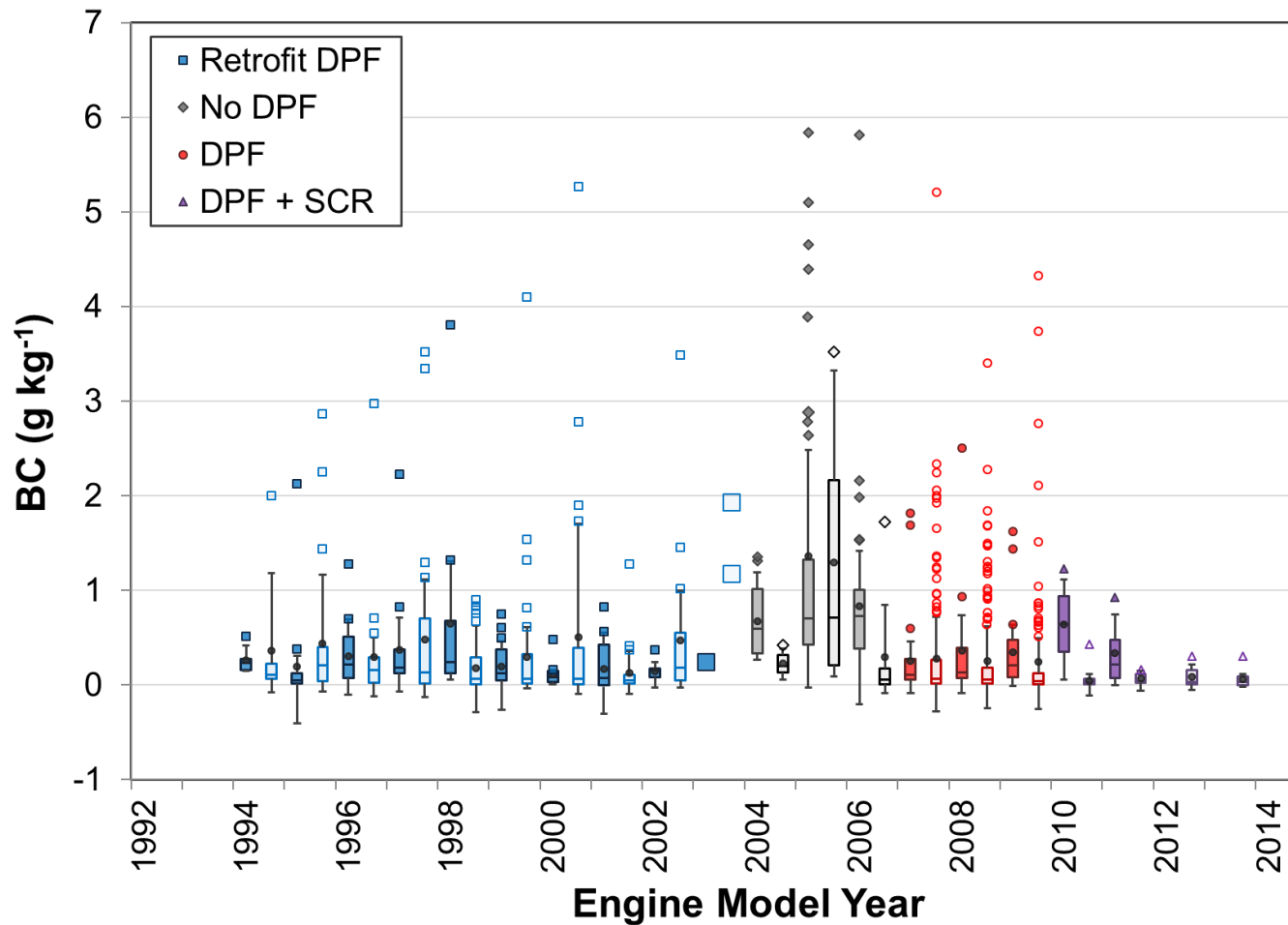

Figure 3.5 Distribution of BC emission factors across engine model years for each individually measured truck. The truck categories as measured in 2011 are shown in shaded boxes and whiskers, and those measured in 2013 are shown in transparent boxes and whiskers. The larger number of outliers for 2013 measurements does not reflect a greater fraction of higher emitting trucks, but is instead the result of generally larger sample sizes during that campaign (**Error! Reference source not found.**). Also, note that there are four extreme outliers for the BC distribution that exceeded the range shown.

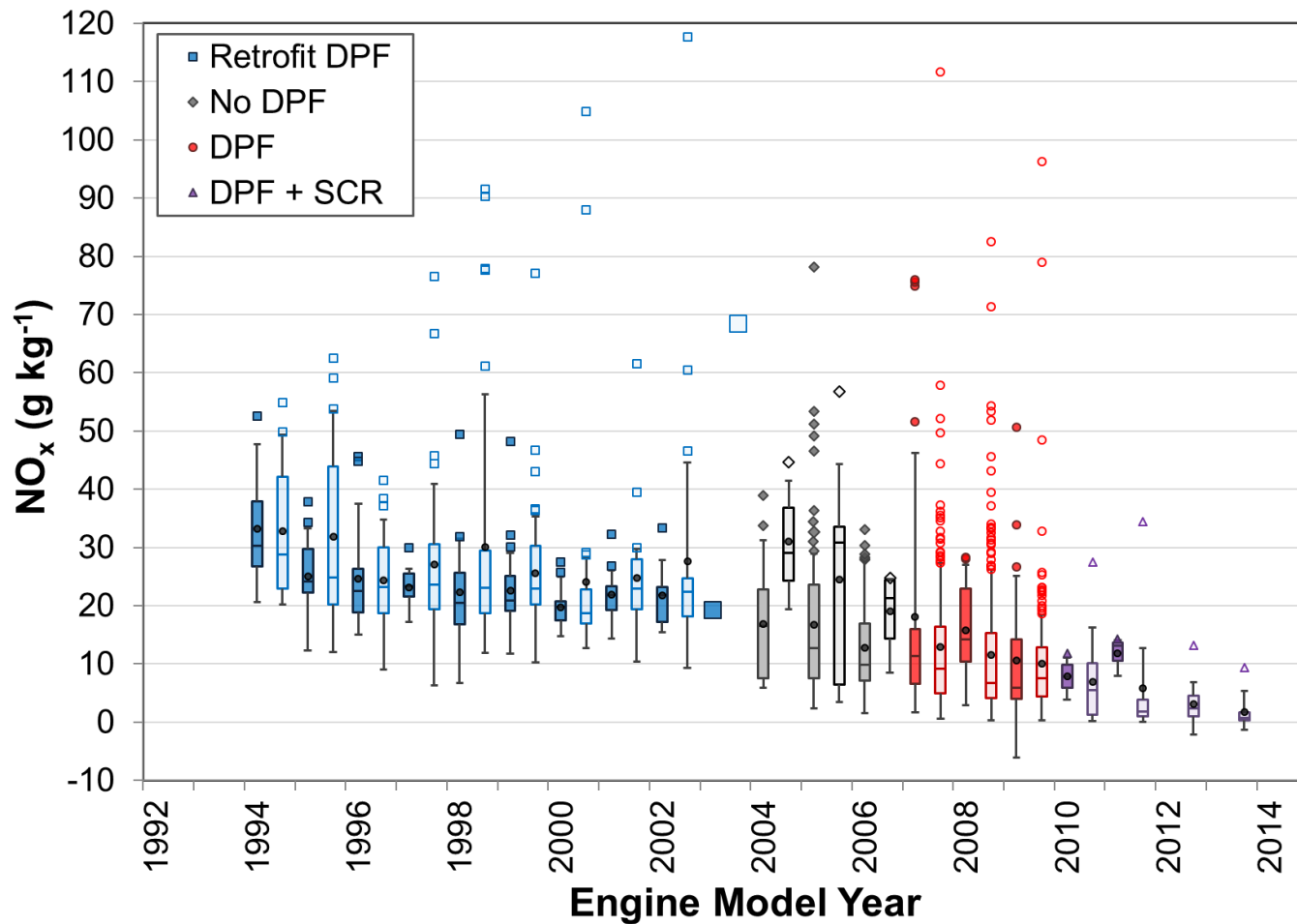

Figure 3.6 Distribution of NO_x emission factors across engine model years for each individually measured truck. The truck categories as measured in 2011 are shown in shaded boxes and whiskers, and those measured in 2013 are shown in transparent boxes and whiskers. The larger number of outliers for 2013 measurements does not reflect a greater fraction of higher emitting trucks, but is instead the result of generally larger sample sizes during that campaign (**Error! Reference source not found.**).

3.2.4 Emissions Variability and Representativeness

In-use emission evaluations as in the current study can assess the emission profiles of thousands of trucks under real-world conditions, which is advantageous compared to laboratory studies that are generally limited by cost and time to small numbers of vehicles. In-use measurements provide emissions snapshots, though. Since truck emission rates may vary in time, for instance with engine load, the measured emission rates reported here may not represent the average emissions of individual trucks. In the current study, repeat measurements of trucks that drove by multiple times were used to characterize variability in measured emission rates at this sampling location.

Repeat measurements of emissions from 207 individual trucks are plotted in Figure 3.7 against corresponding average emission factors for each truck. Scatter about the indicated 1:1 line is due to variability in emission factors. Emissions rates for NO_x and BC were found to vary less than NO_2 and PN. The variability in NO_2 is not likely to be due to measurement uncertainties associated with calculating NO_2 emission factors by difference (i.e., $\text{NO}_2 = \text{NO}_x - \text{NO}$), as this method was well correlated with direct measurements (Figure 2.11). While fleet-average results for PN can still be evaluated, variability in emissions of this pollutant limits the usefulness of single snapshot measurements to characterize emissions from individual trucks.

Measurements made in this study do not include trucks traveling at highway speeds, where engine load and exhaust temperatures are high. This is relevant because these parameters can affect emission control system performance. For example, SCR systems are ineffective when exhaust temperature is low, which can occur during cold starts and at low load/low speed (Misra et al., 2013). However, NO_x emissions from the SCR-equipped trucks in this study were very low (Figure 3.6), which suggests that SCR systems were likely functioning when emissions were sampled. Increased UFP emissions from DPF-equipped trucks have been reported during highway driving when exhaust temperatures were high and during active DPF regeneration events (Herner et al., 2011; Quiros et al., 2014). Active filter regeneration can also increase emitted PM mass (Quiros et al., 2014). In this study, exhaust temperatures were not measured and it was not possible to determine the extent to which filters were actively regenerating. The differences in DPF and SCR performance under highway driving conditions at the Caldecott Tunnel are presented in Chapter 5.

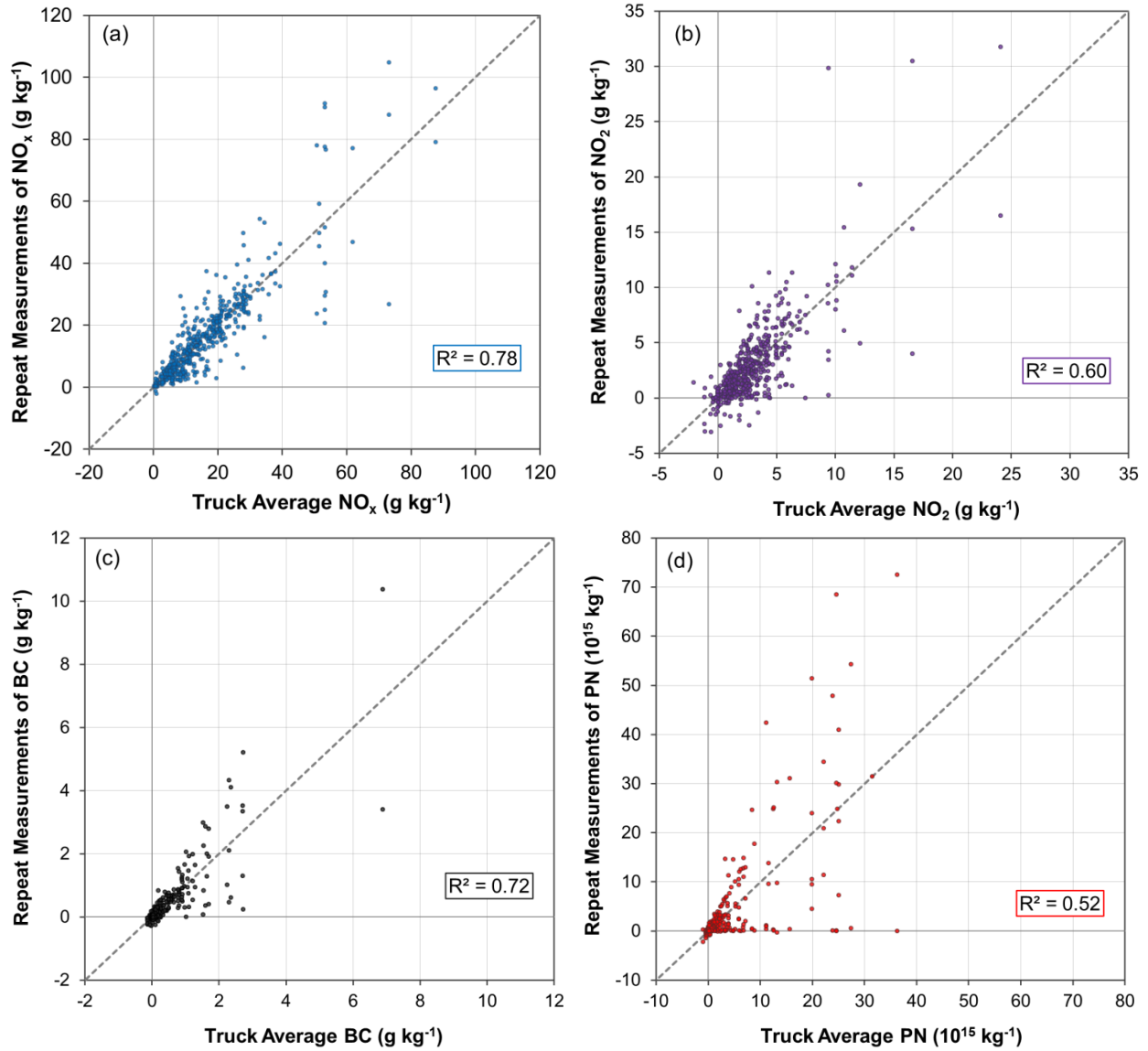

Figure 3.7 Results of repeat measurements for 207 individual trucks; each individual measurement is plotted on the vertical axis against the corresponding average emission factor for each truck on the horizontal axis. Repeatability of the measurement is indicated by the degree of scatter of data points about the dashed 1:1 line.

3.3 Conclusions

Measurements of emissions from drayage trucks operating at the Port of Oakland demonstrate that use of advanced emission control systems effectively reduce the emission rate of targeted pollutants, with average reductions of up to 90% in emitted BC and up to 80% in emitted NO_x per kg of fuel burned (Table 3.2). Use of DPFs to control emitted particle mass can increase tailpipe NO₂ emission rates by up to a factor of seven, but can decrease particle number emissions by one-third to one-half (Table 3.2). The newest trucks with 2010+ engines that are equipped with both DPF and SCR have the lowest emission rates of NO_x, BC, and PN. Moreover, the SCR systems on these trucks are able to mitigate much of the undesirable DPF-related increase in primary NO₂ emissions. As such, as more of these newest (2010+) trucks enter into service, on-road emissions of BC and NO_x from heavy-duty diesel trucks will be reduced, and a key potential negative side effects of diesel particle filters (increased primary NO₂ emissions) will be mitigated.

The following chapters further evaluate the impacts of DPF and SCR systems on emissions from heavy-duty diesel trucks. Chapter 4 assesses the overall impact of the fully implemented Drayage Truck Regulation on the Port of Oakland truck fleet, and considers the performance of emission control systems after several years of aging. Chapter 5 examines how differences in driving mode may influence emissions, by comparing results for trucks driving on an urban arterial roadway at the Port of Oakland with results observed under highway driving conditions at the Caldecott Tunnel.

Chapter 4: Emissions Impacts of the Drayage Truck Regulation

4.1 Introduction

In 1998, California identified diesel exhaust as a toxic air contaminant based on associated health effects (CARB, 1998). Recent health impact assessments by the Bay Area Air Quality Management District found diesel PM to be the dominant source of air pollution associated cancer risk in the San Francisco Bay Area (BAAQMD, 2014). These health assessments further identified the community of West Oakland as one of the most impacted areas in the region, with on-road heavy-duty diesel trucks responsible for a major fraction of the community's total cancer risk due to air pollution. This is greatly due to the fact that West Oakland is adjacent to the Port of Oakland and the Union Pacific/BNSF rail yards and is bounded by three major freeways.

Because of the heavy diesel PM burden associated with drayage truck operations in communities like West Oakland that are near freight-handling facilities like ports and rail yards, the California Air Resources Board implemented the Drayage Truck Regulation. The previous chapter reported the effects of diesel particle filter (DPF) and selective catalytic reduction (SCR) after-treatment control systems on drayage truck emissions as measured at the Port of Oakland. The Drayage Truck Regulation resulted in the rapid modernization of the Port of Oakland fleet to meet the 2007 exhaust emission standard described in Chapter 1. The present chapter examines the emission impacts of this regulation on the Port of Oakland drayage truck fleet during its phased implementation and after full implementation.

As outlined in Table 1.2, the first phase of the Drayage Truck Regulation banned the oldest trucks and required DPF retrofits on the remaining pre-2007 model year engines over a three-year period ending on January 1, 2013. One year later, Phase 2 of this regulation required all trucks that had previously been retrofitted with DPFs be replaced with 2007 or newer engines equipped with DPFs at the time of manufacture, affecting nearly 30% of the Port of Oakland drayage truck fleet. The overall impact of this regulation depends on the extent to which pre-2007 model year engines were replaced with either 2007–2009 engines that include only a DPF versus 2010 and newer engines that also include SCR. From a policy standpoint, the difference in the fleet-wide emission impacts between these two phases of the regulation also merits examination. Most trucks equipped with 1994–2006 model year engines required two significant investments (i.e., first retrofit and then replacement) within a time span of only four years. In terms of further emissions reductions on the fleet-wide scale, was it worth it to replace those older trucks that had just recently been retrofitted? How much additional air quality/emission reduction benefit accrued due to Phase 2 of the Drayage Truck Regulation, relative to emissions reductions already achieved in Phase 1 alone?

To assess these questions as well as the overall emission impacts of the fully implemented Drayage Truck Regulation on the Port truck fleet, additional field measurements were conducted at the Port of Oakland in fall 2015. The 2015 campaign also included an evaluation of the durability of aging DPFs, as well as more in-depth characterization of SCR performance—including an assessment of nitrous oxide (N₂O) formation in SCR-equipped trucks—as more trucks adopted this technology during the second phase of the regulation.

4.2 Results and Discussion

4.2.1 Changes to Port Truck Age Distribution

As the Drayage Truck Regulation was implemented, the truck fleet serving the Port of Oakland modernized rapidly (Figure 4.1). In 2008, prior to the regulation, the median engine age was 11 years and only 2% of Port trucks were equipped with DPFs (BAAQMD, 2009). By early 2013, after Phase 1 was completely in effect, 99% of trucks were equipped with filters, a small fraction (9%) of the fleet was equipped with SCR systems for NO_x control, and the median engine age had decreased to 6 years (Figure 4.1). Phase 2 of the regulation required replacement of pre-2007 engines, which comprised 29% of the fleet in 2013 (see Table 3.1). In 2015, 74% of trucks had 2007–2009 engines with DPFs, 25% had 2010 or newer engines with both DPF and SCR systems, and the median engine age was 7 years (Figure 4.1 and Table 4.1). No trucks equipped with a retrofit DPF were observed in 2015, consistent with regulatory requirements.

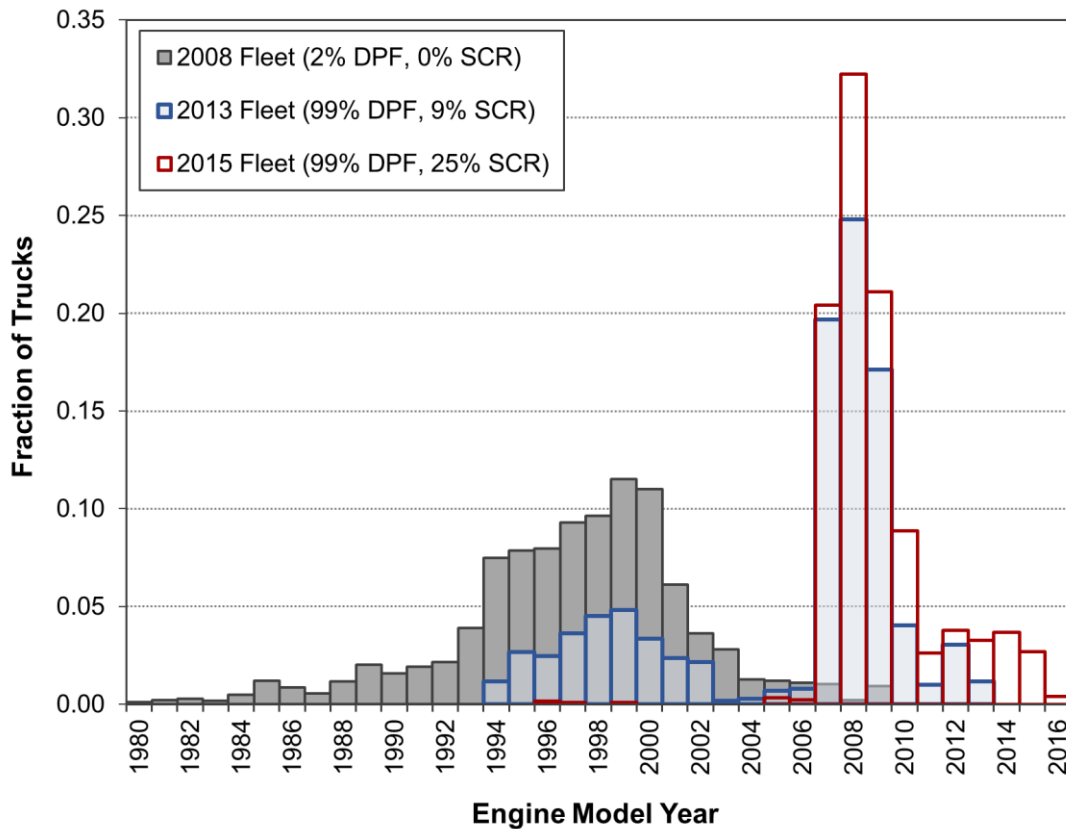

Figure 4.1 Distribution of truck engine model years at the Port of Oakland prior to the Statewide Drayage Truck Regulation in 2008 (BAAQMD, 2009), after full implementation of Phase 1 of the regulation in 2013 (Preble et al., 2015), and after full implementation of Phase 2 of the regulation in 2015. Note that the model year distribution from 2008 is based on truck chassis; some chassis may be one year older than the engine.

Table 4.1 Prevalence of exhaust emission control systems for the Port of Oakland drayage truck fleet after Phase 1 of the Drayage Truck Regulation was in effect in 2013 and after Phase 2 was implemented in 2015.

Emissions Control Category	Engine Model Years	Phase 1, 2013 (N = 1016)	Phase 2, 2015 (N = 1219)
No DPF	1994–2006	1% (n = 15)	1% (n = 11)
Retrofit DPF	1994–2006	28% (n = 281)	0% (n = 0)
DPF	2007–2009	62% (n = 626)	74% (n = 904)
DPF + SCR	2010–2016	9% (n = 94)	25% (n = 304)

4.2.2 Changes in Emission Rates over Time

Fleet-average emission factors are reported in Table A2 of the Appendix and shown below in Figure 4.2 through Figure 4.8. The pre-regulation fleet is characterized using 2009 field measurements from Dallmann et al. (2011). The values for 2009 presented here have been adjusted to account for CO₂ and BC measurement issues, as described in Chapter 2. The 2011 and 2013 measurements took place during the middle and at the end of Phase 1, and the 2015 measurements took place after full implementation of Phase 2 (Table 1.2).

Average pollutant emission rates by emission control category are also presented in Table A2 and in Figure 4.2 through Figure 4.9. The category-average emission factors for all pollutants as measured in each of the three sampling years can also be found in Table A2 of the Appendix.

Nitrogen Oxides. As shown in Figure 4.2, the fleet-average emission rate for total NO_x decreased by 70 ± 9% between 2009 and 2015, compared to the initial 53 ± 8% reduction achieved after the first phase of the Drayage Truck Regulation. Between Phases 1 and 2 of the regulation, NO_x emissions decreased by 36 ± 7%. These NO_x emission reductions are the result of fleet modernization. Given that newer engines must adhere to more stringent emission limits (Figure 1.1), the shift in median engine model year from 1997 to 2008 and associated changes in emission controls led to the reductions in fleet-average NO_x emissions. A comparison of NO_x emissions by control technology category highlights the cause of this dramatic reduction: the newest trucks equipped with both DPF and SCR systems emitted 76 ± 7% less NO_x compared to older trucks with 1994–2006 model year engines.

As a result of the near-universal adoption of DPFs to control PM emissions, fleet-average emissions of NO₂ doubled between 2009 and 2015 (Figure 4.2). This overall change is less than the previously observed increase after implementation of Phase 1 of the regulation, as increased use of SCR in Phase 2 led to a decrease of 23 ± 10% in emitted NO₂ between 2013 and 2015.

Therefore, use of SCR systems on the newest trucks has helped to mitigate the undesired DPF-related increase in tailpipe NO₂ emissions. Even so, the emission rate of NO₂ for the newest trucks with both DPF and SCR systems is nearly double that for trucks without DPFs.

As a result of the increase in NO₂ emission rates and a corresponding decrease in total NO_x emissions, the fleet-average NO₂/NO_x emission ratio increased from 0.03 ± 0.02 in 2009 to 0.22 ± 0.02 in 2015 (Figure 4.3). The NO₂/NO_x ratio is highest for 2007–2009 DPF-equipped engines. Newer trucks also equipped with SCR systems have significantly lower average NO_x and NO₂ emission factors, even though the NO₂/NO_x ratio for 2010+ engines does not show a significant decrease relative to the 2007–2009 engines.

Black Carbon. Between 2009 and 2015, the fleet-average emission rate of BC decreased by 73 ± 22%, compared to the 76 ± 22% reduction previously found over Phase 1 between 2009 and 2013 (Figure 4.4). This result is surprising given that the fraction of the drayage fleet equipped with DPFs remained at 99% across both sampling years. By looking at the changes in engine category-average emission rates over time, the fleet-average BC increase can be attributed to an increase in average BC emission rates for 2007–2009 engines. The median emission rate for this category of engines remained relatively constant (0.05 g kg⁻¹ in 2013 versus 0.04 g kg⁻¹ in 2015), but the mean increased by a factor of 1.5 from 0.26 to 0.39 g kg⁻¹ over the same period (Figure 4.5). This finding indicates that some diesel particle filters are deteriorating as they age, especially for 2007–2009 engines. The distribution of BC emissions across individual trucks and the contributions from high-emitting engines are discussed in more detail later in this chapter.

Fine Particle Mass. As described in Chapter 2, fine particle mass (PM) measured with a DustTrak has not been calibrated specifically for diesel PM emissions. The reference calibration for this instrument is based on light-scattering dust rather than light-absorbing soot/black carbon, the latter being a significant component of diesel exhaust PM emissions. PM emission factors presented here are therefore only used to describe relative changes rather than to define absolute magnitudes of PM emission rates.

As shown in Figure 4.6, the fleet-average PM emission rate decreased by 72 ± 24% between 2009 and 2015. This reduction is smaller than the reduction of 79 ± 23% between 2009 and 2013. As observed for BC, the average PM emission rate increased between 2013 and 2015. The increase in PM can be attributed to a doubling of the average PM emission rate for 2007–2009 model year engines with DPFs between 2013 and 2015 (Figure 4.7).

Particle Number. The fleet-average particle number emission rate decreased by 74 ± 27% between 2009 and 2015, indicating further progress in reducing emissions relative to the initial reduction of 49 ± 17% measured in 2013 relative to the same 2009 baseline (Figure 4.8). Between Phases 1 and 2, the fleet-average PN emission rate decreased by 49 ± 25%. As previously reported in Chapter 3, under these driving conditions and at this location, trucks equipped with DPFs have significantly lower PN emission rates compared to trucks without filters. The newest engines that are equipped with both DPF and SCR systems have the lowest PN emission factors, emitting one-fourth the number of particles per kg of fuel burned compared to trucks without filters.

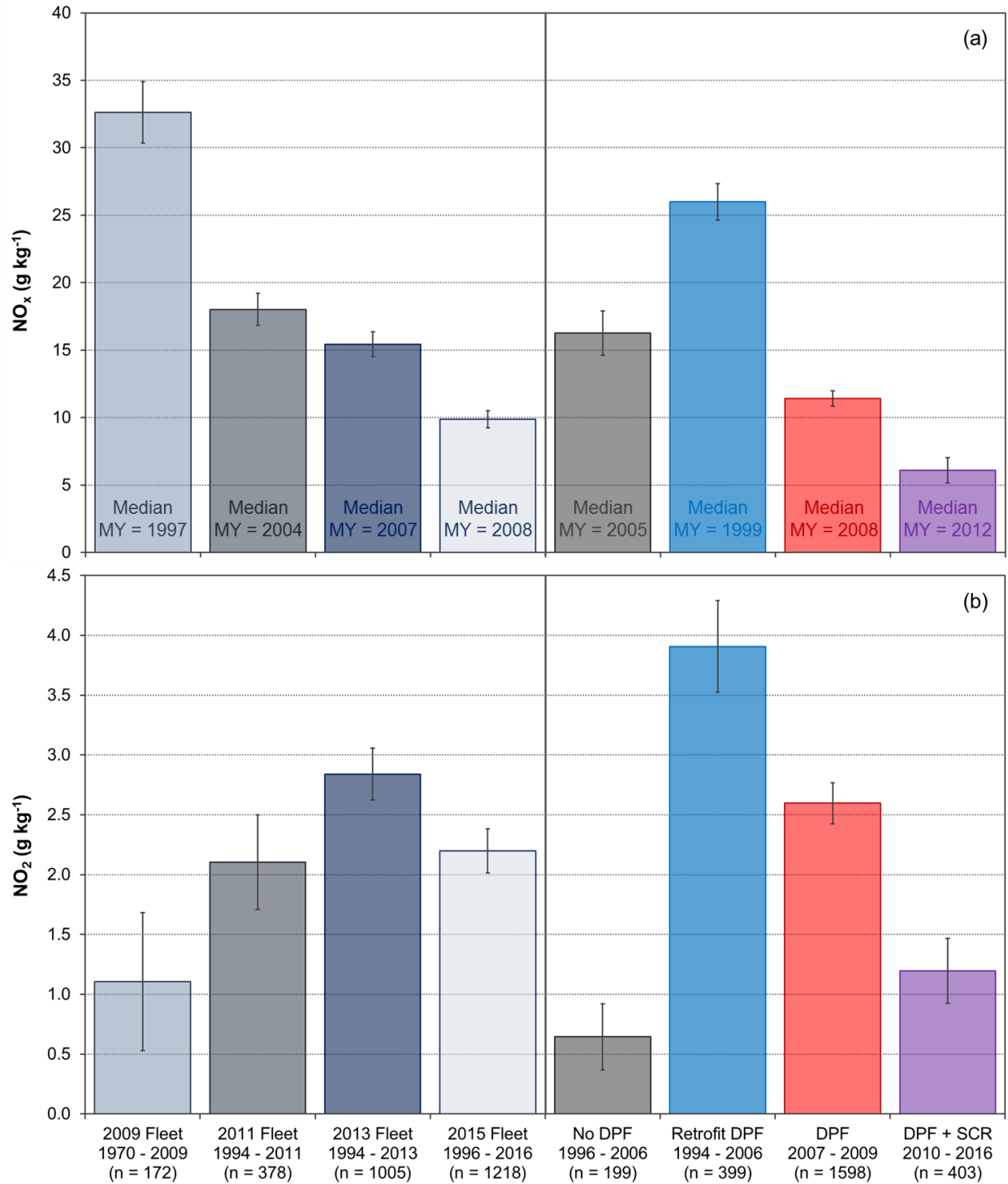

Figure 4.2 Fleet-average emission factors for (a) NO_x and (b) NO_2 as measured in 2009, 2011, 2013, and 2015 at the Port of Oakland (left panel), as well as category-average values for combined 2011 + 2013 + 2015 measurements (right panel).

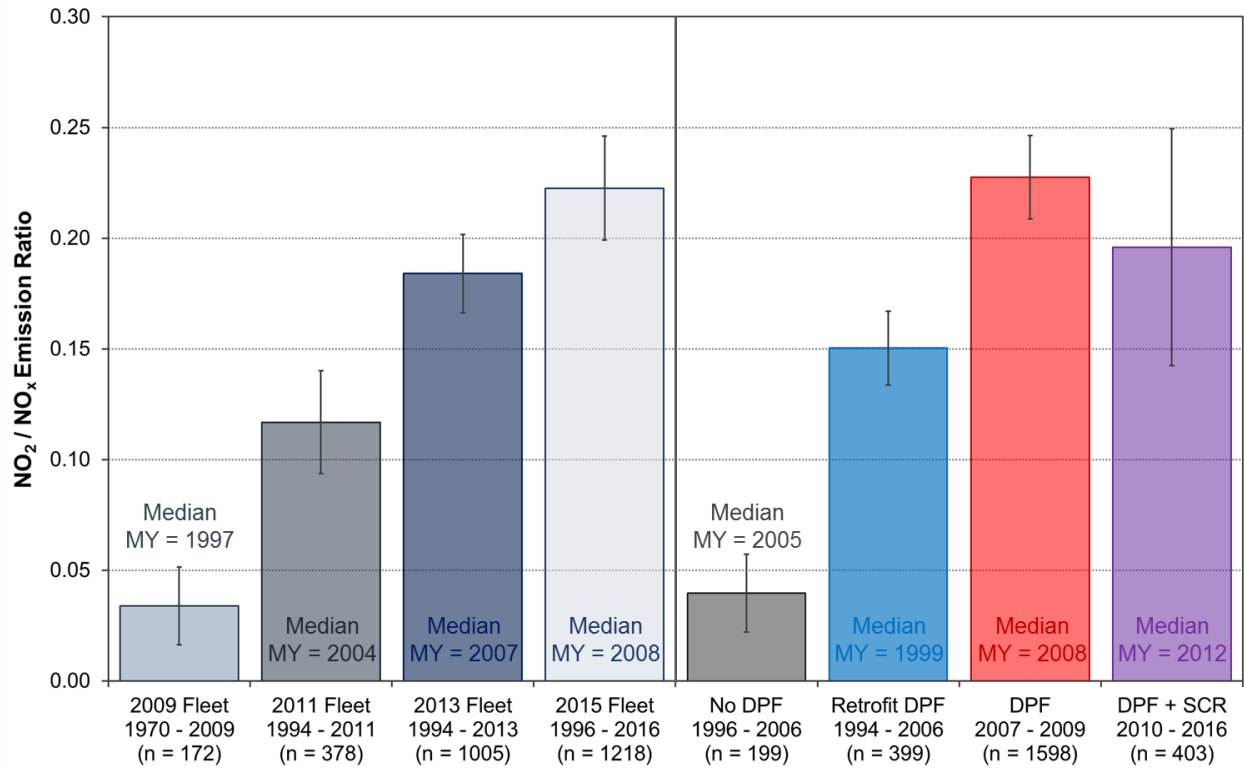

Figure 4.3 Fleet-average emission ratios of NO_2/NO_x as measured in 2009, 2011, 2013, and 2015 at the Port of Oakland (left panel), as well as category-average values for combined 2011 + 2013 + 2015 measurements (right panel).

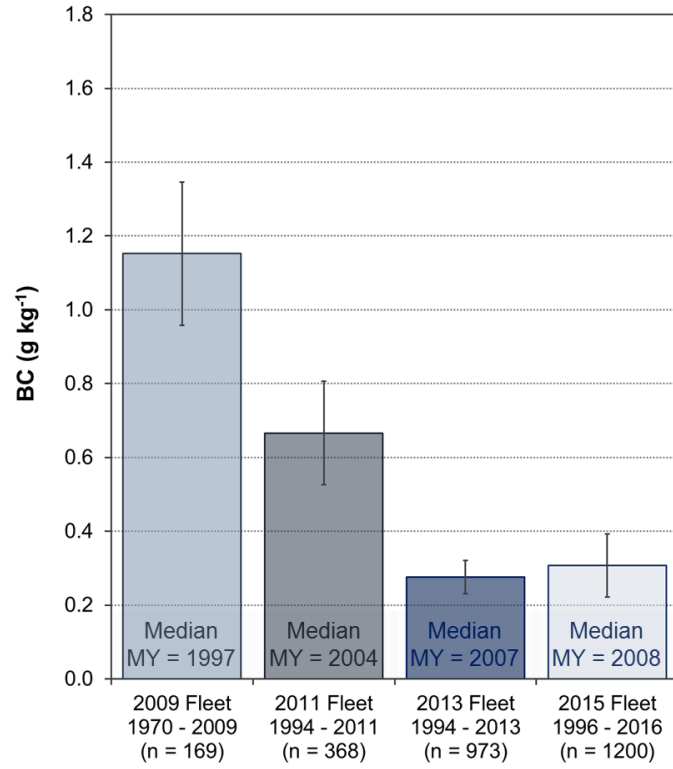

Figure 4.4 Fleet-average BC emission factors as measured in 2009, 2011, 2013, and 2015 at the Port of Oakland.

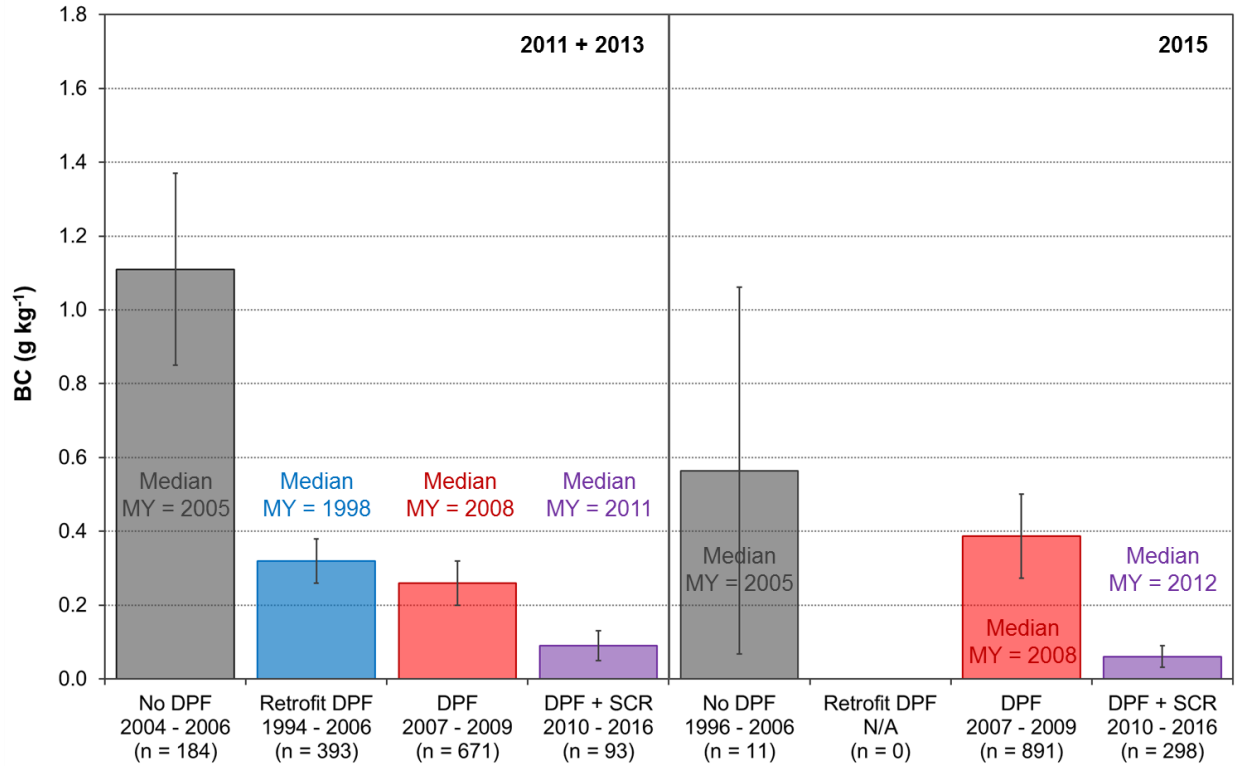

Figure 4.5 Average BC emission factors as a function of installed emission control systems, for the combined 2011 + 2013 data reported in Table 3.2 (left panel) compared to average values measured in 2015 as part of the current study (right panel).

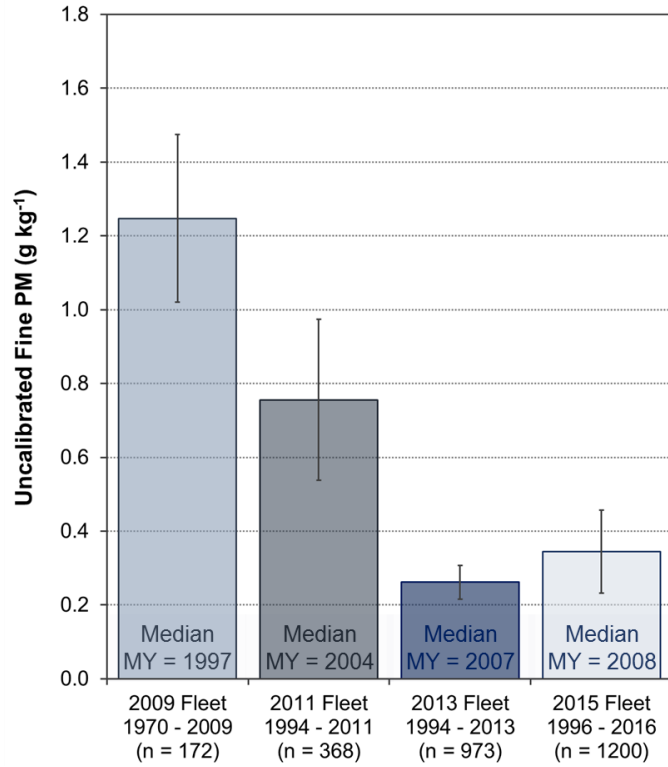

Figure 4.6 Fleet-average fine PM emission factors as measured in 2009, 2011, 2013, and 2015 at the Port of Oakland. Emission factors are derived from fine PM concentrations measured with an uncalibrated instrument (see text), so the focus is the emission trend over time rather than absolute values in a specific year.

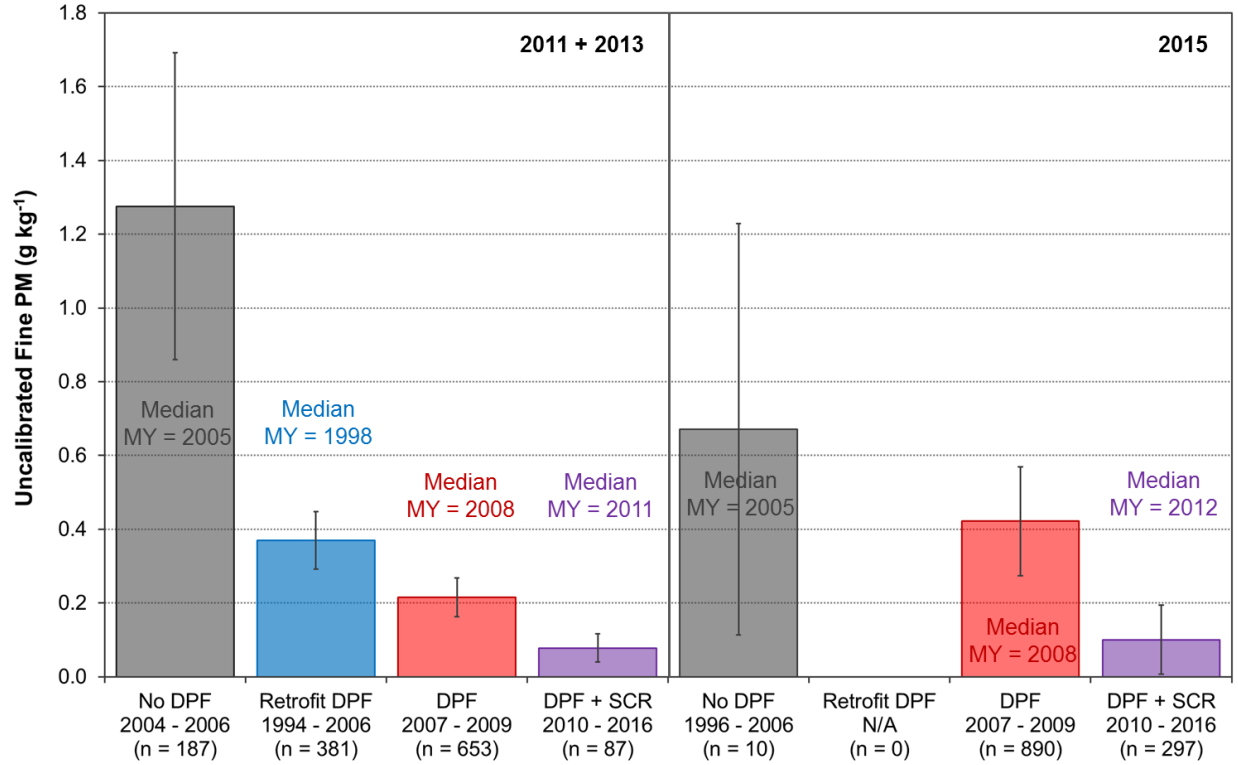

Figure 4.7 Average fine PM emission factors by control category type for the combined 2011 + 2013 data (left panel) compared to the average values found in the current study, as measured in 2015 (right panel). Note that these emission factors are derived from fine PM concentrations measured with an uncalibrated instrument (see text), so the emission trends by control category rather than the absolute values are considered to be relevant to the fleet's PM emissions.

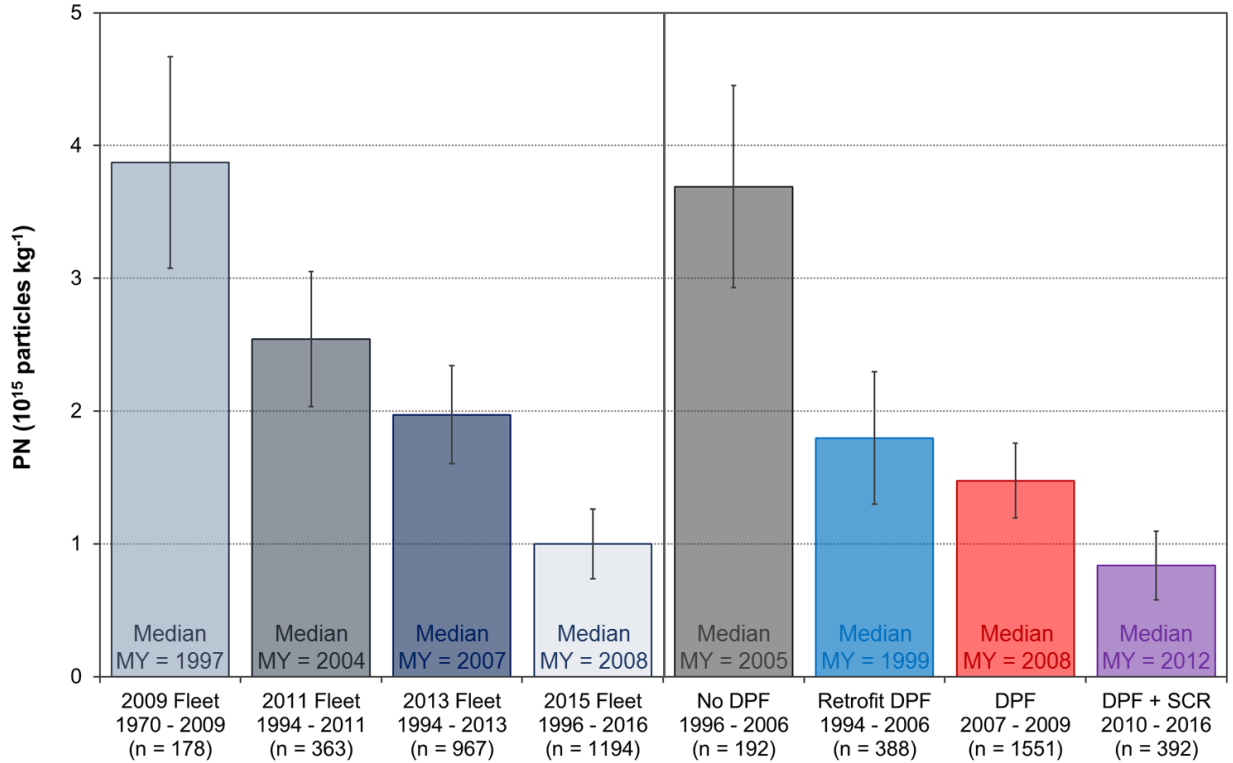

Figure 4.8 Fleet-average PN emission factors as measured in 2009, 2011, 2013, and 2015 at the Port of Oakland (left panel), as well as category-average values for combined 2011 + 2013 + 2015 measurements (right panel).

4.2.3 Nitrous Oxide

Selective catalytic reduction systems have the potential to form nitrous oxide (N₂O), a potent greenhouse gas, via oxidation of ammonia in the presence of excess NO₂ and oxygen in the system (Hallstrom et al., 2013). With the increase in SCR use driven by accelerated fleet turnover and increasing numbers of 2010+ engines, N₂O emissions are now of greater interest. The fleet-average emission rate of N₂O in 2015 was 0.16 ± 0.03 g kg⁻¹, with SCR-equipped engines emitting nearly seven times more N₂O per kg of fuel burned than trucks without SCR (Figure 4.9). These fleet- and category-average N₂O emission rates are below California's 0.1 g bhp-hr⁻¹ limit for 2014 and newer model year engines (CARB, 2014b), which equates to 0.6 g kg⁻¹ assuming brake specific fuel consumption of 0.17 kg hp-hr⁻¹ (Heywood, 1988). For the truck fleet measured in 2015, the measured N₂O emission rate for 6% of trucks exceeded this standard, of which 75% were SCR-equipped trucks. Of the 300 trucks with SCR systems that were observed in 2015, 18% exceeded the N₂O emission limit. Though N₂O was not measured in prior years, these results suggest that the fleet-average N₂O emission factor increased markedly between 2009 and 2015, as the fraction of Port drayage trucks equipped with SCR increased from 0 to 25%.

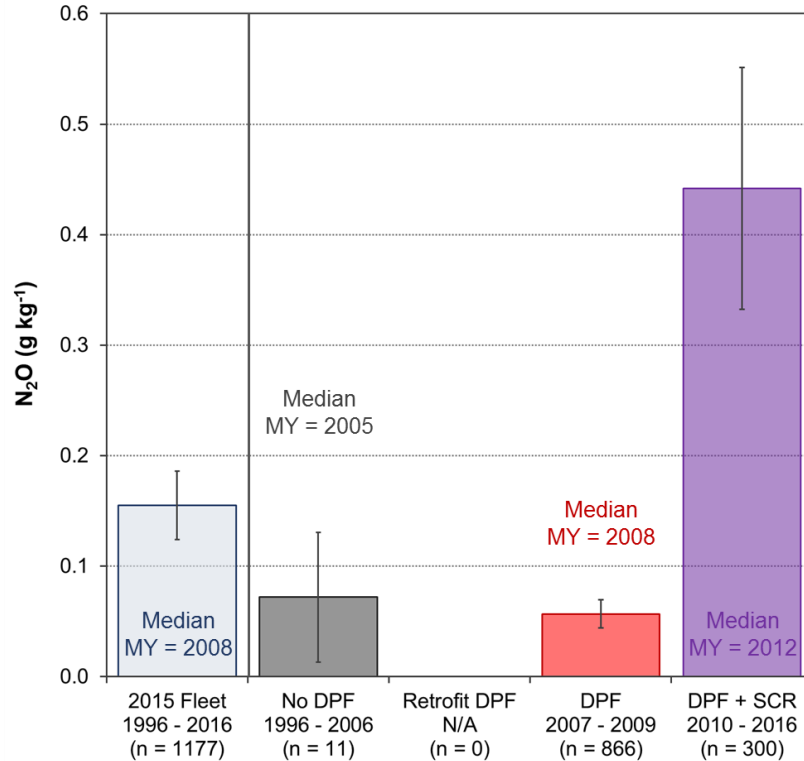

Figure 4.9 Fleet-average (left panel) and control category-average (right panel) N₂O emission factors as measured in 2015 at the Port of Oakland.

4.2.4 Emission Factor Distributions

BC and NO_x emission factor distributions are shown by model year for all trucks originally equipped with DPFs (i.e., 2007 and newer engines), as measured in 2013 and 2015, in Figure 4.10. In both field studies, BC emission factor distributions for 2007–2009 engines are more skewed than for 2010 and newer engines, as indicated by mean values that often exceed the 75th percentile of the distribution for these model years. Emission factor distributions for 2007 and 2008 engines show greater spread in 2015 than in 2013, as indicated by the wider BC emission factor ranges in the box-whisker plots for these engines (Figure 4.10). Also for 2007 and 2008 model years, the mean BC emission rate increased in 2015 relative to corresponding 2013 values, while the median value remained approximately the same. BC emission factor distributions follow the same trends as the category-average results previously presented in Figure 4.5, and also highlight the increasing impact of high emitters relative to the general fleet. These observations indicate deterioration in DPF system performance over time has become an issue for nearly 10% of 2007 and 2008 engines, after six to seven years of in-use service. These issues are arising relatively early in the ~30-year service life of heavy-duty diesel engines.

Mean values for NO_x emission factors as a function of engine model year generally fall between the median and the 75th percentile levels (Figure 4.10). This is consistent with the earlier finding of a less skewed distribution for NO_x compared to BC in Chapter 3. NO_x emissions for some

SCR-equipped trucks were higher than the 75th percentile value for 2007–2009 engines without SCR, indicating that some SCR systems may not have been operational when exhaust was sampled. There is no evidence of a shift in NO_x emission factor distributions between 2013 and 2015 for trucks without SCR (i.e., 2007–2009 engines). Data for trucks with 2010 and newer engines are limited and should be interpreted with caution.

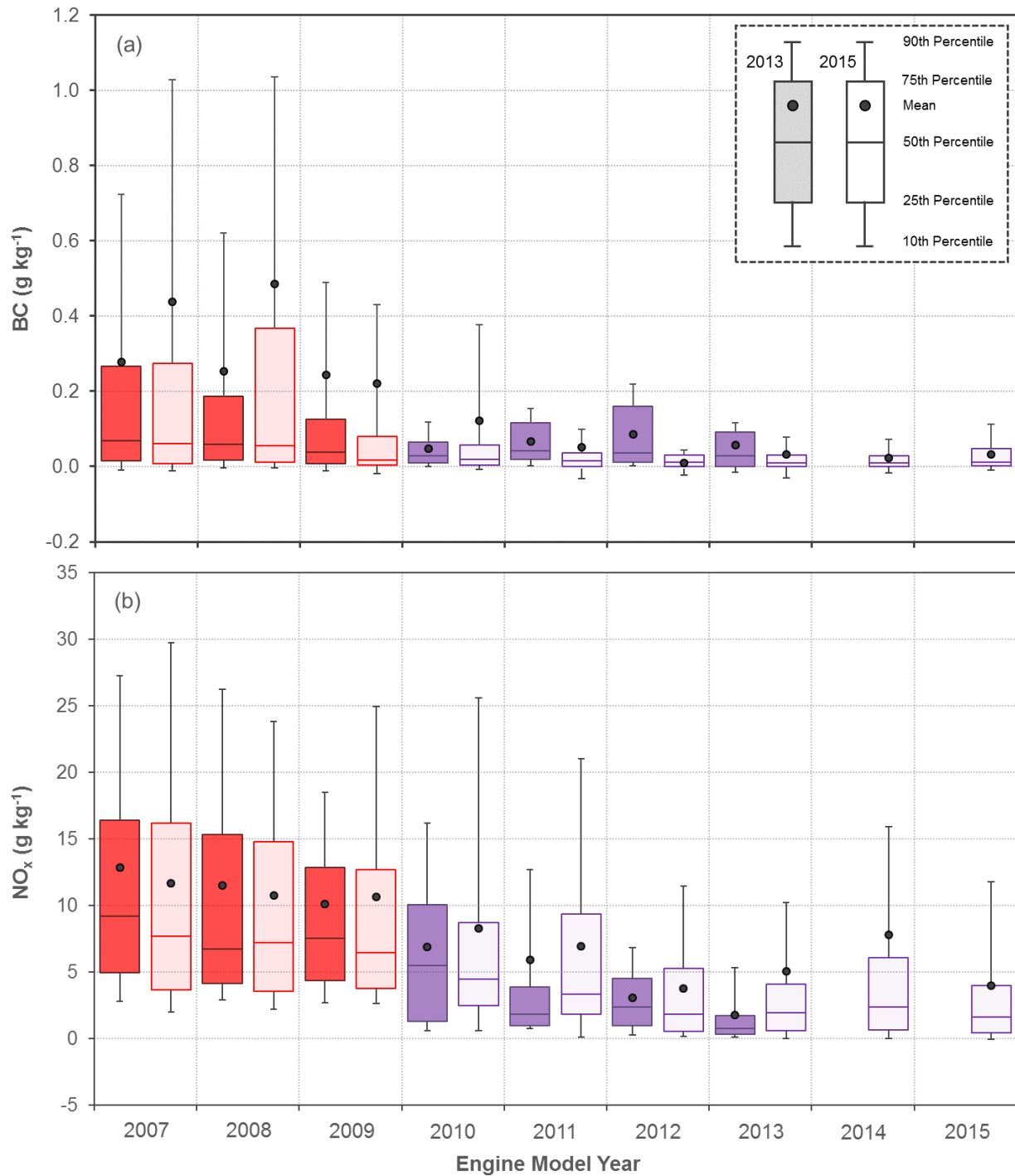

Figure 4.10 Distribution of (a) BC and (b) NO_x emission factors by engine model year for DPF-equipped trucks as measured in 2013 (left bar in each pair) and 2015 (right bar in each pair). Trucks with 2007–2009 engines are shown in red; those with 2010 and newer engines, equipped with both DPF and SCR, are shown in purple.

4.2.5 DPF Deterioration

Figure 4.5 and Figure 4.10 indicate that performance of some DPFs installed on 2007–2009 engines has deteriorated over time, whereas DPFs on 2010 and newer engines have remained effective at reducing emitted BC. Figure 4.11–Figure 4.13 delve further into the issue of DPF failures as the age of engines and filter systems increase.

The distributions of BC emission factors for 2007–2009 engines over time are shown in Figure 4.11. High emitters are defined as those trucks with BC emission factors greater than 1.1 g kg^{-1} , the category-average for diesel trucks without filters (Table A2). This value is 18 times the national PM emission standard of $0.01 \text{ g hp-hr}^{-1}$ for 2007 and newer engines, assuming brake specific fuel consumption of 225 g kWh^{-1} or $0.17 \text{ kg hp-hr}^{-1}$ (Heywood, 1988). As highlighted in Figure 4.11, the fraction of 2007–2009 trucks classified as high-emitters in all three measurement years was similar, between 6–8% of the truck category.

Figure 4.12 shows the contribution of high emitters to the total truck fleet's cumulative BC emissions as the Drayage Truck Regulation was implemented. In 2009, when only 2% of the fleet was DPF-equipped, 33% of trucks in the fleet were high emitters, and these trucks were responsible for 69% of total BC emissions. When DPFs were used to control emissions throughout the truck fleet in 2013, 52% of BC emissions could be attributed to high emitters that constituted 6% of the fleet. In 2015, the fraction of the fleet identified as high-emitting remained at 6%, but those trucks were responsible for 65% of total BC emissions. Of the 73 trucks that comprised the high-emitter fraction in 2015, 93% were 2007–2009 engines with DPFs, 4% were 2010 and newer engines with DPF and SCR systems, and only 3% were trucks without filters.

To summarize, a small minority (less than 10%) of the Port drayage trucks observed in 2015 were responsible for the majority of BC emissions, and the highest emitters were mostly DPF-equipped 2007–2009 model year engines. Whereas the fraction of high-emitting trucks in the 2007–2009 model year category has remained approximately constant, the emission rates for these high-emitting trucks appear to be increasing over time.

BC emissions were categorized by engine manufacturer for the 2007–2009 trucks sampled in the 2015 study to determine if there were differences in performance and durability of these particle filters (Figure 4.13). The most common engines installed in this category of trucks were supplied by Detroit Diesel, Cummins, and Volvo, together representing 81% of the 2007–2009 model year engines in the Port fleet. Trucks with Volvo engines had significantly lower BC emissions than trucks with Detroit Diesel, Cummins, and Mercedes Benz engines (Figure 4.13). Trucks with Detroit Diesel, Cummins, and Mercedes Benz engines also had the highest fractions of trucks identified as high-emitters. Between these three manufacturers, though, there was no significant difference in average BC emitted by those high emitters (Figure 4.13). The average BC emission rate by these high emitters was nearly an order of magnitude greater than the 2015 fleet-average, however, and a factor of 7 times greater than the 2007–2009 engine model year category average observed in 2015.

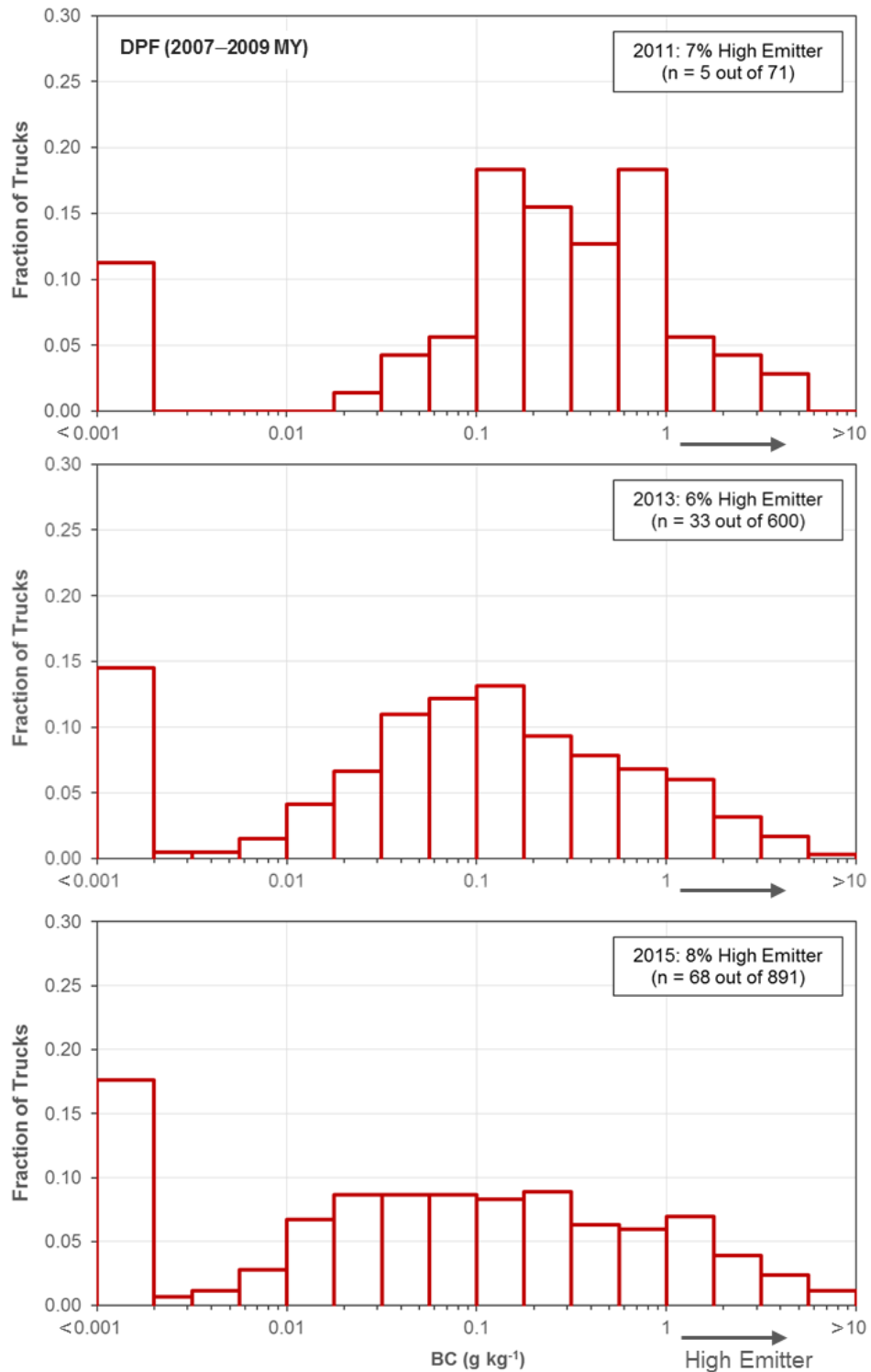

Figure 4.11 Distribution of BC emission factors for 2007–2009 model year engines equipped with DPFs, as measured in 2015. High-emitting trucks are defined as having a BC emission factor greater than the category-average of 1.1 g kg^{-1} for trucks without DPF (see text).

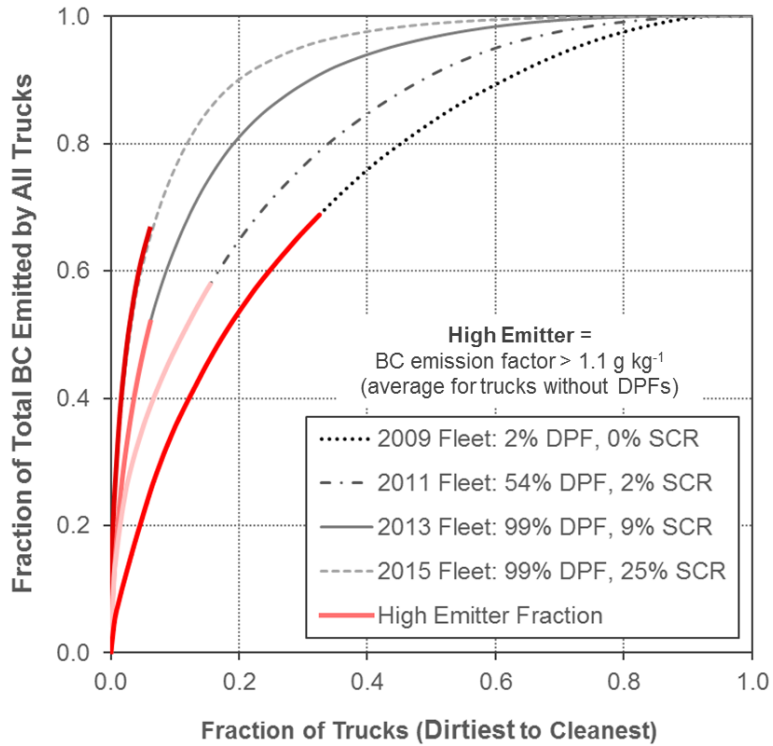

Figure 4.12 Cumulative emission factor distribution for BC over time as the Drayage Truck Regulation was implemented at the Port of Oakland. Emission factors for individual trucks were ranked from highest to lowest, with high-emitters defined as those trucks emitting BC at levels greater than the category-average of 1.1 g kg⁻¹ for trucks without DPF (see text).

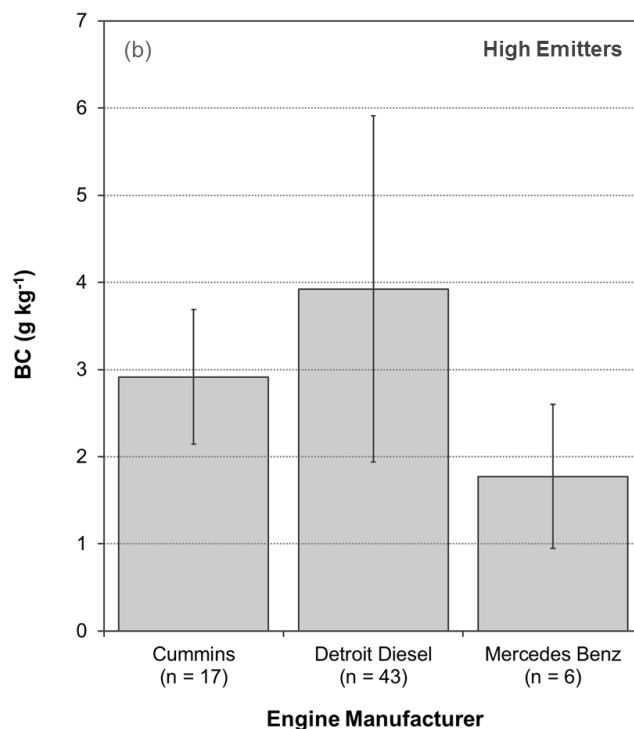
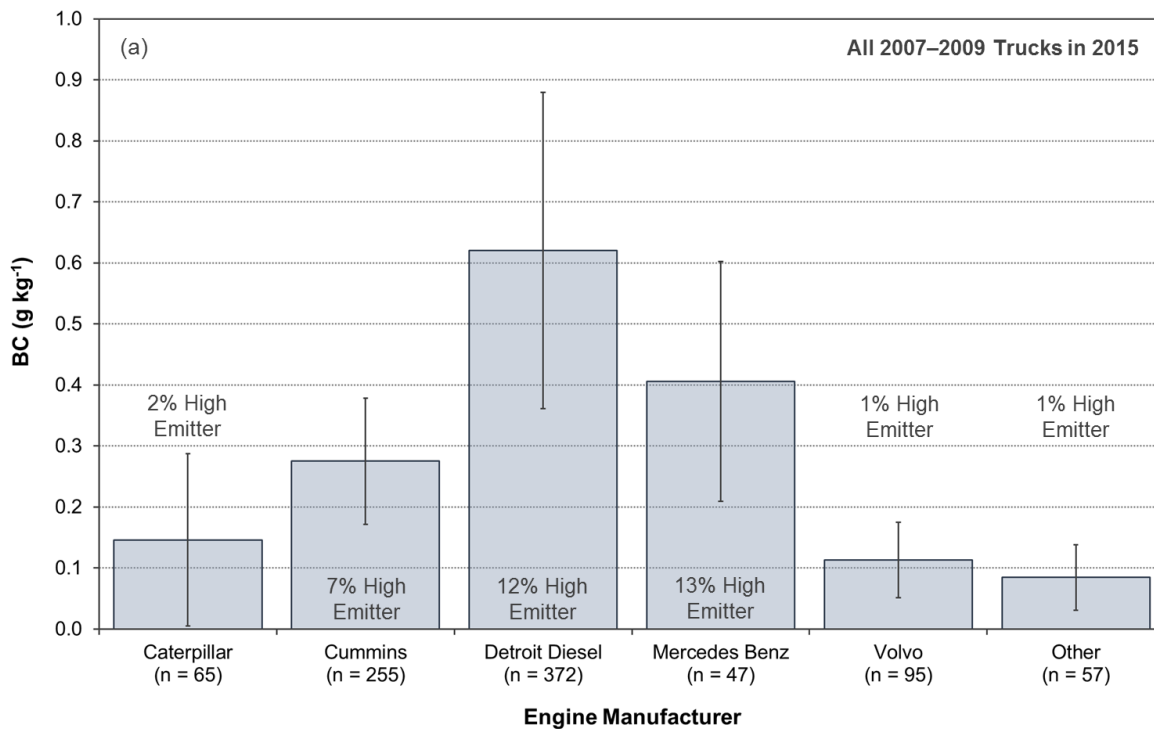

Figure 4.13 Average BC emission factors by engine manufacturer for (a) all 2007–2009 trucks measured in 2015, and (b) those 2007–2009 trucks classified as high emitters. The definition of a high-emitter used here is trucks emitting BC at levels above 1.1 g kg^{-1} , which is characteristic of trucks without DPF in prior studies at this site (see text).

4.2.6 Emissions Variability of High-Emitters

The exhaust emissions from 224 individual trucks was sampled multiple times during the 2015 campaign. Analysis of these repeat measurements indicates that BC high-emitters tend to be more chronic rather than intermittent in nature. Of the 73 trucks classified as high emitters in 2015, emissions were sampled more than once from 23 of these trucks, and 61% of the repeat measurements also qualified as high-emission events. The average BC emission factor for all 73 high-emitting trucks sampled in 2015 was $3.38 \pm 1.19 \text{ g kg}^{-1}$. For those 23 high-emitting trucks with replicate measurements, the average BC emission rate when all repeat measurements are included (i.e., including the 40% that did not qualify as high-emission events when measured again) is slightly lower at $2.65 \pm 0.82 \text{ g kg}^{-1}$, but still 8.6 times greater than the 2015 fleet-average of $0.31 \pm 0.09 \text{ g kg}^{-1}$.

If all high-emitters were removed from the 2015 fleet, the fleet-average emission rate would decrease to $0.11 \pm 0.01 \text{ g kg}^{-1}$. Such a decrease would have led to a *reduction* of $61 \pm 20\%$ in BC emission factors between Phases 1 and 2 of the Drayage Truck Regulation, rather than the observed $12 \pm 35\%$ *increase*. The combined effect of both phases of the regulation would then have been a $91 \pm 23\%$ decrease in emitted BC between 2009 and 2015. Greater efforts to prevent trucks from becoming high-emitters in the first place (e.g., via improved durability of emission control systems), and/or identifying and repairing high-emitting trucks, should be considered as possible next steps for reducing BC emissions.

4.3 Conclusions

Emission reductions observed in these studies at the Port of Oakland over six years are approximately double the 39 and 30% reductions in BC and NO_x emission factors measured for trucks at the nearby Caldecott Tunnel over a period of nine years (Ban-Weiss et al., 2008). Trucks using the Caldecott Tunnel were not subject to any retrofit/replacement requirements during the period from 1997 to 2006 considered by Ban-Weiss et al. (2008). Emission reductions at the Port have clearly occurred at a more rapid pace than what would have been achieved by natural fleet turnover alone.

The second phase of the Drayage Truck Regulation provided added benefits in terms of fleet-average emission rates for nitrogen oxides and particle number. These additional changes in fleet-wide emissions are due to the replacement of older engines that had been recently retrofit with DPFs and were characterized by the highest average NO_x , NO_2 , and PN emission rates of DPF-equipped trucks (Table A2). This replacement of nearly one-third of the higher emitting fraction of the Port fleet resulted in increasing NO_x emissions reductions from $53 \pm 8\%$ over Phase 1 to $70 \pm 9\%$ over Phases 1 and 2. Similarly, by removing the category of trucks with the highest primary NO_2 emission rate, the fleetwide increase in DPF-related NO_2 emissions was partially mitigated and limited to a doubling of the pre-regulation average value of 1.11 g kg^{-1} , rather than the initial factor of 2.6 increase observed over Phase 1. Finally, the replacement of retrofit trucks during Phase 2 further reduced the fleet's average PN emission rate from $49 \pm$

17% over Phase 1 to $74 \pm 27\%$ over Phases 1 and 2. These results indicate that replacement rather than retrofit may be the most effective policy in terms of fleetwide emissions impact.

The Truck and Bus Regulation has similarly accelerated replacement and/or retrofit of older trucks, extending beyond ports and rail yards to include heavy-duty diesel trucks operating anywhere in California, regardless of origin or destination. Results of these local, accelerated changes at the Port of Oakland therefore provide a preview of how diesel truck emissions are likely to change across the state in the next few years as statewide fleet modernization requirements are implemented. These results are also relevant at the national scale, as larger numbers of new trucks with advanced emission control systems enter into service. However, it appears that some particle filters are failing as they age, and thus a small fraction of DPF-equipped trucks are now responsible for a large fraction of BC emissions at the Port of Oakland. In order to maintain the air quality benefits of these emission control system investments, improved filter designs that provide enhanced durability, and inspection and maintenance/repair programs may be needed for heavy-duty diesel trucks.

Chapter 5: Driving Mode Impacts on DPF and SCR Performance

5.1 Introduction

The previous chapters have characterized the performance of diesel particle filters and selective catalytic reduction systems under low-speed, arterial roadway driving conditions for drayage trucks en route to the Port of Oakland. Driving mode is known to affect both engine-out emissions and the performance of advanced emission control technologies. In particular, SCR systems require a minimum temperature in order to maintain proper functionality (Misra et al., 2013), and nucleation events in the exhaust of DPF-equipped trucks depend on the exhaust temperature and engine load (Vaaraslahti et al., 2004; Biswas et al., 2008; Herner et al., 2011). Driving conditions at the Caldecott Tunnel reflect driving under higher engine load, with trucks climbing a 4% uphill roadway grade at generally higher speeds compared to the Port of Oakland. As a result, engines are running hotter due to higher power output required for uphill driving, compared to conditions observed at the Port of Oakland sampling location. Both site and truck fleet differences provide an opportunity to evaluate effects of the new emission control technologies under two different driving regimes.

This chapter examines how driving mode may affect performance of DPF and SCR systems in controlling particle mass and nitrogen oxide emissions, with potential additional effects on other co-emitted pollutants. Pertinent results from Chapters 3 and 4 are reproduced here for convenience and compared to results of field measurements at the Caldecott Tunnel in 2014 and 2015.

As at the Port of Oakland, measurements at the Caldecott Tunnel were made from the instrumented van positioned above passing traffic with the analyzers outlined in Table 2.1. Sampling methodology and data analysis were the same at these two sites, but the regulated fleets were different. All trucks operating at the Port of Oakland were required to prove compliance with the Drayage Truck Regulation, else entrance to the Port was denied. Self-reporting for the highway fleet affected by the Truck and Bus Regulation, on the other hand, was voluntary. For this reason, it was more difficult to successfully categorize each truck that passed by; if the truck owner did not self-report, there was limited information available to classify the engine by emission control category. This constraint required measuring the exhaust plumes of more individual trucks at the Caldecott Tunnel to attain a sufficient sample size for some analyses. The plumes of individual trucks were easier to distinguish at the Caldecott Tunnel, though, as trucks were typically less clustered together at the Tunnel than at the Port, as described in Dallmann et al. (2011). There was also a more varied mix of truck types at the Caldecott Tunnel. The Tunnel truck fleet included cement mixers, dump trucks, tractor trailers, flatbeds, and construction equipment, in addition to drayage trucks hauling containers. Finally, the Truck and Bus Regulation allows for some exemptions, meaning that some older engines will remain in service and will not follow the retrofit or replacement requirements.

5.2 Results and Discussion

In the results that follow, emission rates by control category are from the aggregated data sets from measurements at the Caldecott Tunnel in 2014 and 2015 and combined 2011, 2013, and 2015 data sets from the measurements at the Port of Oakland. These category-average emission rates for each site are summarized in Table A3 of the Appendix, along with the calendar year fleet-average emission rates for the Caldecott Tunnel in 2014 and 2015 and for the Port of Oakland in 2015 (reproduced from Table A2).

5.2.1 Caldecott Tunnel Fleet Composition

Since the start of the Truck and Bus Regulation in 2012, the on-road highway fleet operating at the Caldecott Tunnel has increasingly adopted DPF and SCR systems (0). Figure 5.1 shows the age distribution of heavy-duty diesel trucks as measured in 2014 and 2015, and Table 5.1 summarizes the fleet composition by emission control category.

In 2015, 80% of the Caldecott Tunnel fleet was equipped with DPFs and nearly half of the fleet had also adopted SCR. While DPF use was not as widespread as was found for the post-Drayage Truck Regulation fleet operating at the Port of Oakland in the same calendar year, SCR use was nearly twice as high at the Caldecott Tunnel (Table 4.1 and Table 5.1). Because of this higher fraction of newer engines with SCR, the median engine age of the Tunnel fleet in 2015 was one year newer than that of the Port of Oakland fleet, even though the Tunnel fleet was comprised of a wider range of engine model years overall.

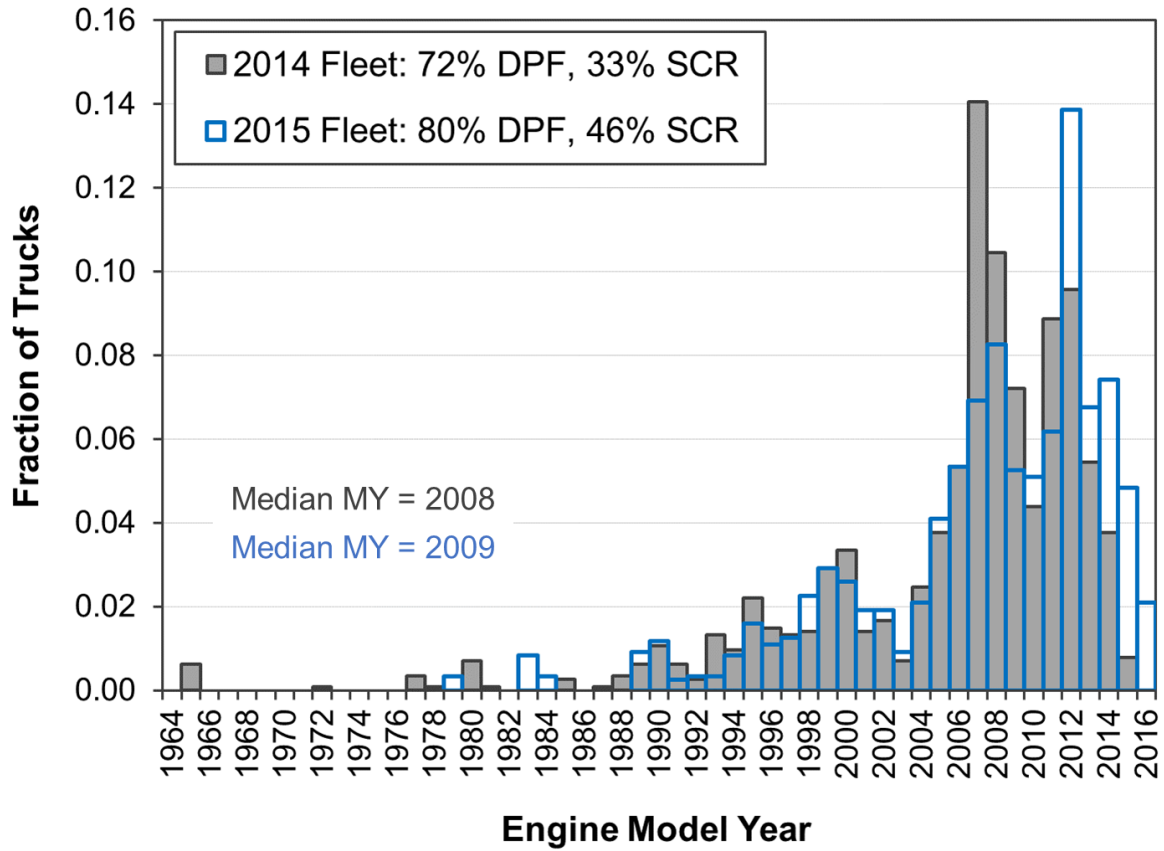

Figure 5.1 Distribution of heavy-duty diesel trucks operating at the Caldecott Tunnel in 2014 and 2015.

Table 5.1 Composition of the Caldecott Tunnel fleet of heavy-duty diesel trucks by emission control category, as measured in 2014 and 2015.

Calendar Year	Range of Engine Model Years	No DPF (pre-2007)	Retrofit DPF (1994–2006)	DPF (2007–2009)	DPF + SCR (2010+)
2014 (72% DPF, 33% SCR)	1965–2015 (N = 1139)	28% (n = 320)	8% (n = 88)	31% (n = 357)	33% (n = 374)
2015 (80% DPF, 46% SCR)	1979–2016 (N = 1198)	20% (n = 242)	13% (n = 157)	20% (n = 245)	46% (n = 554)

5.2.2 Site Differences in Oxidized Nitrogen Emissions

Fleet-average emission rates of nitrogen oxides differed at the two sampling locations in 2015. N₂O emission rates were 3.5 times higher at the Caldecott Tunnel than at the Port of Oakland (Table A3). As shown in Figure 5.2, the N₂O emission rates from trucks at the Caldecott Tunnel frequently exceeded California’s exhaust standard of 0.6 g kg⁻¹ for brake specific fuel consumption equal to 0.17 kg hp-hr⁻¹ (Heywood, 1988; CARB, 2014b). Of the SCR-equipped trucks, more than one-third exceeded this standard. The average emission rate by those 336 trucks was 2.4 g kg⁻¹, nearly 4 times the emission limit. Moreover, the average emission rate of N₂O by SCR-equipped trucks at the Caldecott Tunnel was more than double that observed at the Port of Oakland: SCR-equipped trucks at the Port of Oakland emitted on average 0.44 ± 0.11 g N₂O per kg of fuel burned, while the same category of trucks operating under highway/uphill driving conditions at the Caldecott Tunnel emitted on average 1.00 ± 0.19 g kg⁻¹ (Figure 5.2 and Table A3). This result supports the notion that N₂O emissions by SCR systems is driving mode dependent, with the magnitude of emissions influenced by system temperature and engine load.

The Caldecott Tunnel fleet-average NO_x emission rate was 1.5 times the value observed at the Port of Oakland in 2015 (Table A3). Higher NO_x emissions at the Tunnel may be due to the greater number of older engines operating at this location, as the Port of Oakland’s fleet was nearly entirely comprised of 2007 and newer model year engines (Table 4.1 and Table 5.1). If the fleet-average calculation is instead limited to only those trucks with 2007+ engines, the NO_x emission rate at the Port of Oakland was slightly higher by a factor of 1.1. Between the two categories of trucks included in that average, though, there were opposite trends. The average NO_x emission rate for 2007–2009 trucks with DPFs at the Tunnel was 40% higher than the corresponding Port value (Figure 5.3 and Table A3), indicative of higher engine loads that increase the amount of engine-out NO_x per kg of fuel burned. The category-average NO_x emission rate for 2010+ SCR-equipped trucks at the Port, on the other hand, was 50% higher

than the Tunnel's category-average (Figure 5.3 and Table A3), suggesting more functional SCR systems under the highway driving condition.

Fleet-average emissions of NO₂ were 20% higher at the Port of Oakland. This difference is likely due to the higher prevalence of SCR for the Caldecott Tunnel truck fleet, which mitigates the undesired DPF-related increase in tailpipe NO₂ emissions. At the Caldecott Tunnel, trucks equipped with SCR reduced emissions NO_x and NO₂ by factors of 6.5 and 3.5, respectively, relative to older trucks retrofit with DPFs (Table A3, Figure 5.3). The reductions observed at the Port of Oakland between these two categories of emission controls was similar for NO₂ (factor of 3.3) but smaller for NO_x (factor of 4.3). Use of SCR systems on trucks observed driving through the Caldecott Tunnel was sufficient to completely offset the DPF-related increase in primary NO₂ emissions (Figure 5.3 and Table A3).

To evaluate further an apparent driving mode dependence in total NO_x emission rates, the distributions of NO_x emission factors by engine model year are compared for the Port of Oakland and the Caldecott Tunnel. As shown in Figure 5.4, the distributions of NO_x emission factors for 2007–2009 model year engines with DPFs at the Caldecott Tunnel were shifted towards higher emission rates in 2015. This shift reflects the previously mentioned difference between the category-average emission rates measured at these two locations, in which the Tunnel average is 1.4 times the Port value (Table A3).

The opposite trend was observed for 2010 and newer engines that were equipped with SCR systems. On average, the NO_x emission rate by SCR-equipped trucks at the Port of Oakland was 1.5 times the average measured at the Caldecott Tunnel. This trend can also be seen in the distributions by engine model year shown in Figure 5.4, although the difference is not as apparent as the shift observed in the 2007–2009 distributions. Even so, the extents of the 90th percentile whiskers for all 2010+ engines measured at the Caldecott Tunnel were smaller than the corresponding whiskers for the Port of Oakland measurements. In many cases across these 2010 and newer engine model years, the average values and the interquartile ranges (i.e., the size of the boxes shown) were also smaller at the Caldecott Tunnel. These differences show that SCR systems were more functional at the Caldecott Tunnel and more effectively reduced NO_x emissions by the trucks operating at that location. This result is likely because engine temperatures under the highway driving condition more frequently met the minimum operational temperature that these systems require.

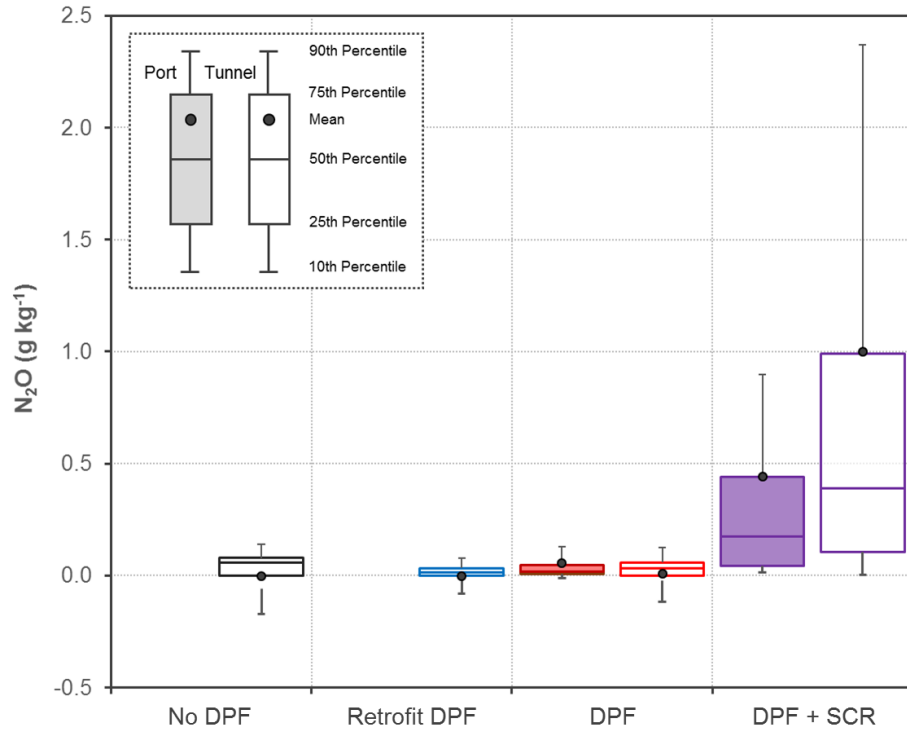

Figure 5.2 Distributions of N₂O emission factors by emission control category from measurements at the Port of Oakland (darker shaded boxes) and at the Caldecott Tunnel (more transparent boxes) in 2015.

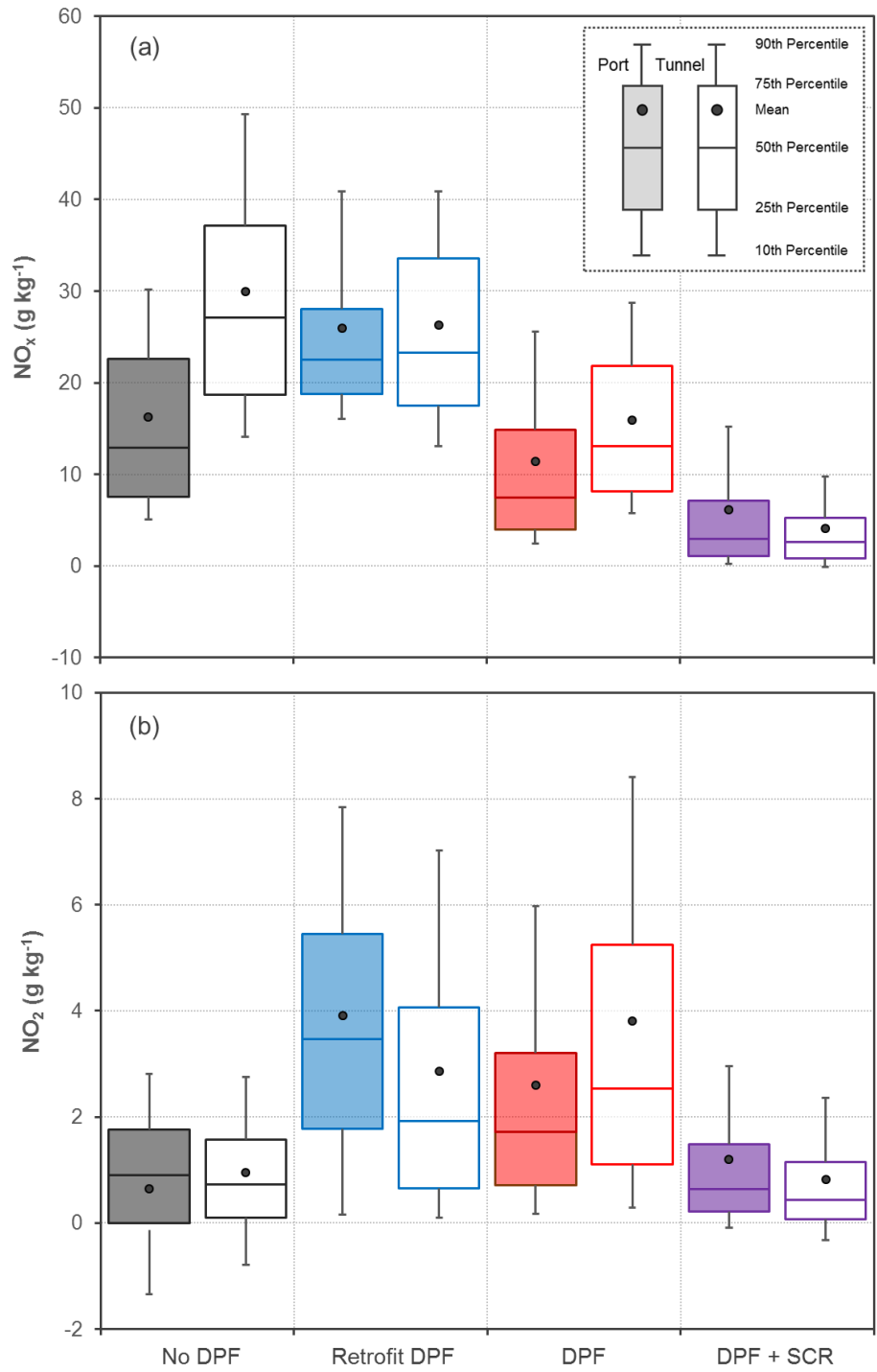

Figure 5.3 Distributions of (a) NO_x and (b) primary NO₂ emission factors by emission control category from the combined 2011, 2013, and 2015 measurements at the Port of Oakland (darker shaded boxes) and combined 2014 and 2015 measurements at the Caldecott Tunnel (more transparent boxes).

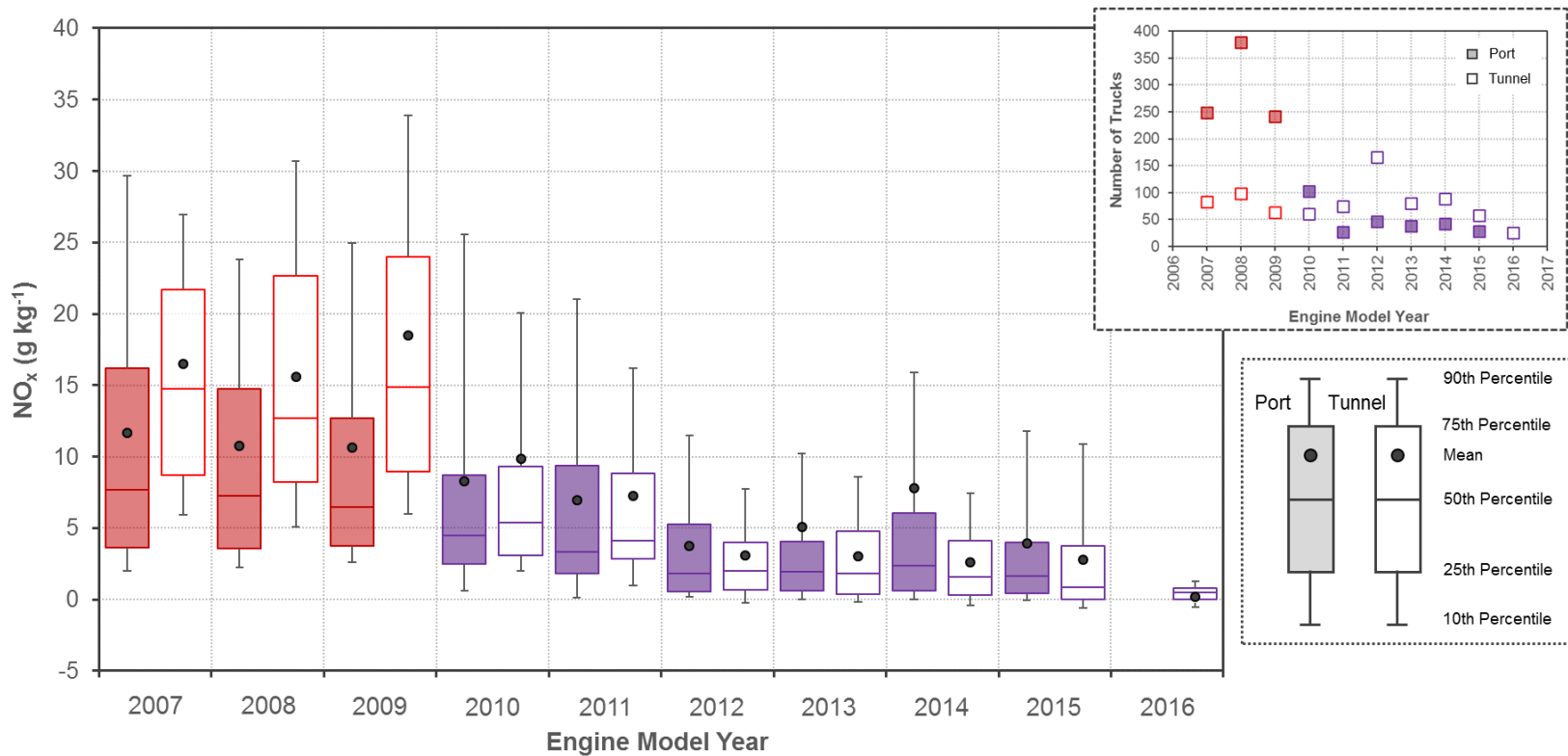

Figure 5.4 Distribution of NO_x emission factors by engine model year, as measured at the Port of Oakland and Caldecott Tunnel in 2015. The sub-figure in the upper right corner shows the number of measurements included in these distributions, while the legend in the lower right corner defines the boxes-and-whiskers shown.

5.2.3 Site Differences in Particle Number Emissions

Particle number emission rates show a distinct driving mode dependence. While the fleet-average BC emission rate was similar between the two sites, the fleet-average PN emission rate at the Caldecott Tunnel was 6.9 times the fleet-average value at the Port of Oakland (Figure 5.5 and Table A3). This increase was observed across all four truck control categories, with a likely explanation that higher engine loads and temperatures at the Caldecott Tunnel led to increased particle formation via evaporation of engine oil and subsequent nucleation to form ultrafine particles (Vaaraslahti et al., 2004; Biswas et al., 2008; Herner et al., 2011).

DPF-equipped trucks at the Port of Oakland reduced average PN emission rates by a factor of 2–4 relative to trucks without filters (Figure 5.5 and Table A3). Conversely, at the Caldecott Tunnel, there was either no significant change or a significantly large increase in the average PN emission rate relative to trucks without filters, depending on the vintage of DPF used (Figure 5.5 and Table A3). Trucks without filters emitted a comparable number of particles on a per kg of fuel basis as trucks with 2007+ engines equipped with DPFs at the time of manufacture, with and without SCR. The PN emission rate by trucks retrofitted with DPFs, on the other hand, was on average 1.7 times greater than that of trucks without filters (Figure 5.5 and Table A3).

A similar trend was observed for the size-resolved particle number emission rate distributions determined for each emission control category at the Caldecott Tunnel. As shown in Figure 5.6, the particle size distributions for the trucks without filters and original equipment DPFs were similar across the particle sizes shown, whereas the distribution for trucks with retrofit filters was significantly greater in magnitude. In particular, the emission rate of particles less than 50 nm in diameter was on average 3.2 times the average emission rate for the other three categories of trucks. This significant increase in nucleation mode particles explains the observed increase in total PN emission rate by retrofit DPF trucks shown in Figure 5.5. Previous studies have similarly found increased emissions of nucleation mode particles in trucks with catalyzed DPFs—like those commonly used in retrofit systems that rely on passive regeneration—operating under conditions including cruise driving cycles, higher engine temperatures, and high engine loads (Vaaraslahti et al., 2004; Biswas et al., 2008; Herner et al., 2011).

All four truck categories at the Caldecott Tunnel exhibited a similar near-unimodal distribution of particles emitted in the size range of 5.6 and ~200 nm with a peak value around 10 nm (Figure 3.1). This trend differs from the previously presented trimodal distribution observed for trucks without DPFs at the Port of Oakland, and the related observation that DPFs were most effective at removing particles larger than ~15 nm under those driving conditions. These dissimilar trends by sampling location again emphasize how driving mode can impact the effects diesel particle filters have on emitted particle number.

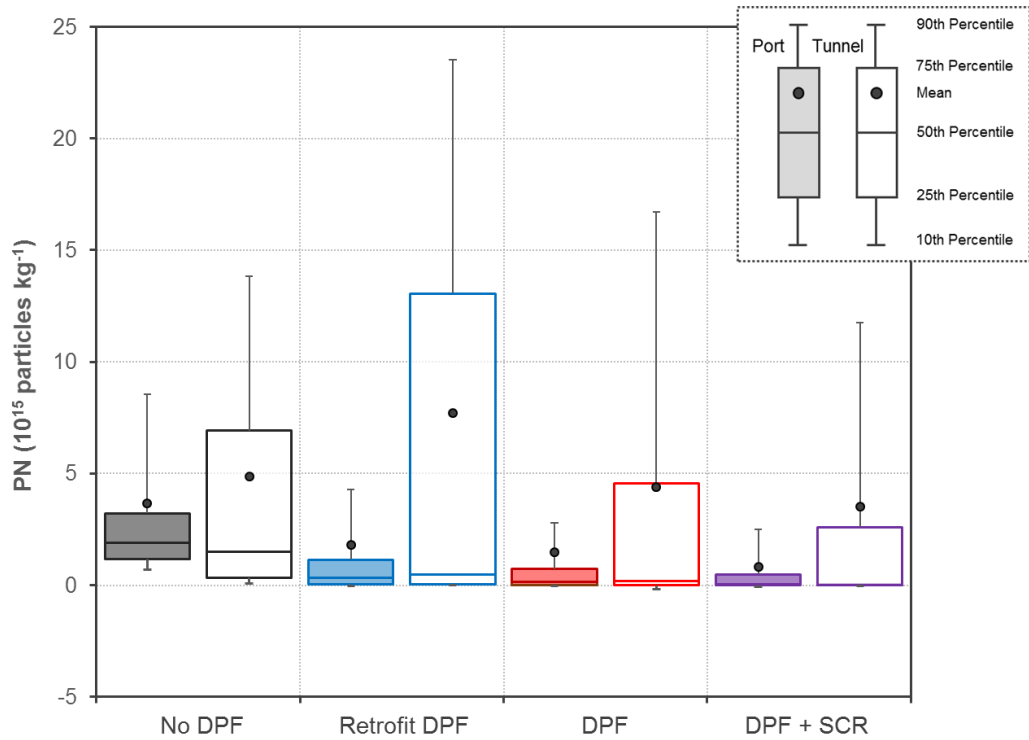

Figure 5.5 Distributions of PN emission factors by emission control category from the combined 2011, 2013, and 2015 measurements at the Port of Oakland (darker shaded boxes) and combined 2014 and 2015 measurements at the Caldecott Tunnel (more transparent boxes).

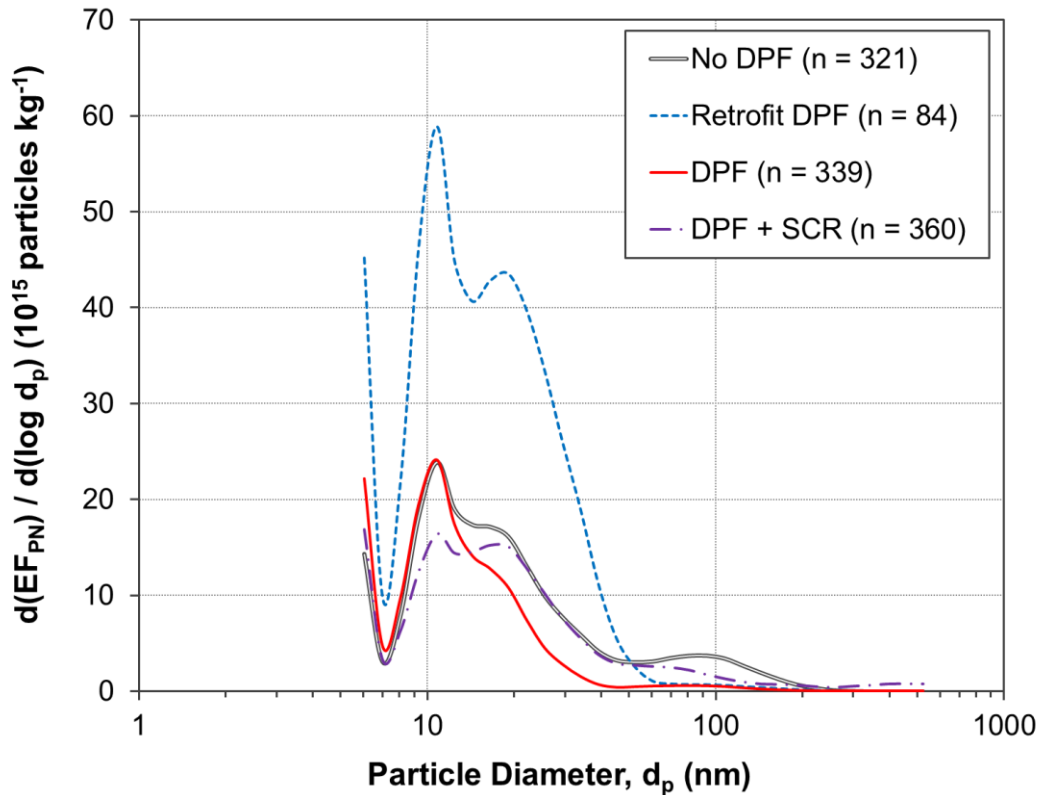

Figure 5.6 Characteristic particle number emission rate distributions for each emission control technology, based on 2014 field measurements at the Caldecott Tunnel.

5.2.4 DPF Durability

Figure 5.7 shows the distribution of BC emission factors by emission control category as measured separately in 2014 and 2015 at the Caldecott Tunnel. On average, the newest trucks equipped with both DPF and SCR systems showed reductions of $96 \pm 18\%$ in BC emissions per kg of fuel burned, compared to trucks without DPFs (Table A3). DPF systems appear to be comparably effective at the Port of Oakland, with BC reductions of $94 \pm 32\%$ between trucks with DPF and SCR and those without (Table A3). As was also observed for the Port of Oakland drayage truck fleet, the performance of DPFs on trucks with 2007–2009 model year engines in the Caldecott Tunnel fleet appeared to deteriorate over time (Figure 5.7). Between 2014 and 2015, the median BC emission factor for this truck category was constant at 0.04 g kg^{-1} , but the average value increased from 0.18 to 0.30 g kg^{-1} (Figure 5.7).

While both sampled fleets show evidence of deterioration over time for DPFs installed on 2007–2009 engines, the impact of these failing filters appears to be more significant at the Port of Oakland. Figure 5.8 shows the distributions of BC emission factors by engine model year, as measured at the Port of Oakland and the Caldecott Tunnel in 2015. While the distributions for

the 2010 and newer model year engines at both locations were comparable in terms of average values, interquartile ranges, and extents of the 90th percentile whiskers, the same was not true for the 2007–2009 engines. Across all three engine model years in this category, the Port of Oakland’s drayage truck fleet showed a more skewed distribution of BC emission factors towards higher emitters, as evidenced by the generally larger boxes and whiskers (Figure 5.8). For the 2007 and 2009 distributions, the Port’s average BC emission rates were also much larger than the corresponding Caldecott values.

Based on the BC emission factor threshold of 1.1 g kg^{-1} used in Chapter 4, the frequency of high emitting DPF-equipped trucks was much higher among Port drayage trucks compared to the truck fleet observed at the Caldecott Tunnel. At the Port of Oakland, 6% of all DPF-equipped trucks were high emitters, compared to only 1% of trucks with filters sampled at the Caldecott Tunnel. Specifically by engine model year, the high emitter fraction of 2007 and 2008 trucks was 9% each at the Port of Oakland but only 2 and 4%, respectively, at the Caldecott Tunnel. The impact of these high emitters on fleet-wide emissions were not as skewed at the Tunnel relative to the Port. As reported in Figure 4.12, the high emitter fraction of the drayage fleet was responsible for 65% of emitted BC. At the Caldecott Tunnel, ten DPF-equipped trucks were classified as high emitters, eight of which were 2007–2009 trucks. These trucks had an average BC emission rate of $4.7 \pm 2.8 \text{ g kg}^{-1}$, represented 1% of the overall fleet, and were responsible for 14% of the fleet’s BC emissions. Of the BC emissions from DPF-equipped trucks, however, these ten trucks were responsible for 40% of BC emissions. While removing this small number of high emitters has no significant effect on the fleet’s overall average BC emission rate ($0.28 \pm 0.06 \text{ g kg}^{-1}$ with high emitters versus $0.24 \pm 0.05 \text{ g kg}^{-1}$ without), removal of these ten trucks would reduce the average BC emission factor for DPF-equipped trucks by nearly half ($0.12 \pm 0.04 \text{ g kg}^{-1}$ with high emitters versus $0.07 \pm 0.01 \text{ g kg}^{-1}$ without).

It is likely that the impact of high emitters at the Caldecott Tunnel will increase over time as more DPF-equipped trucks enter into service with the continued implementation of the Statewide Truck and Bus Regulation. It is not clear why more of the DPFs on 2007–2009 trucks show evidence of deterioration at the Port of Oakland than at the Caldecott Tunnel. Perhaps it can be explained by the more variable driving on an arterial street near the Port compared to the highway driving found at the Caldecott Tunnel, but more work would have to be completed to better understand how these driving mode differences impact DPF deterioration.

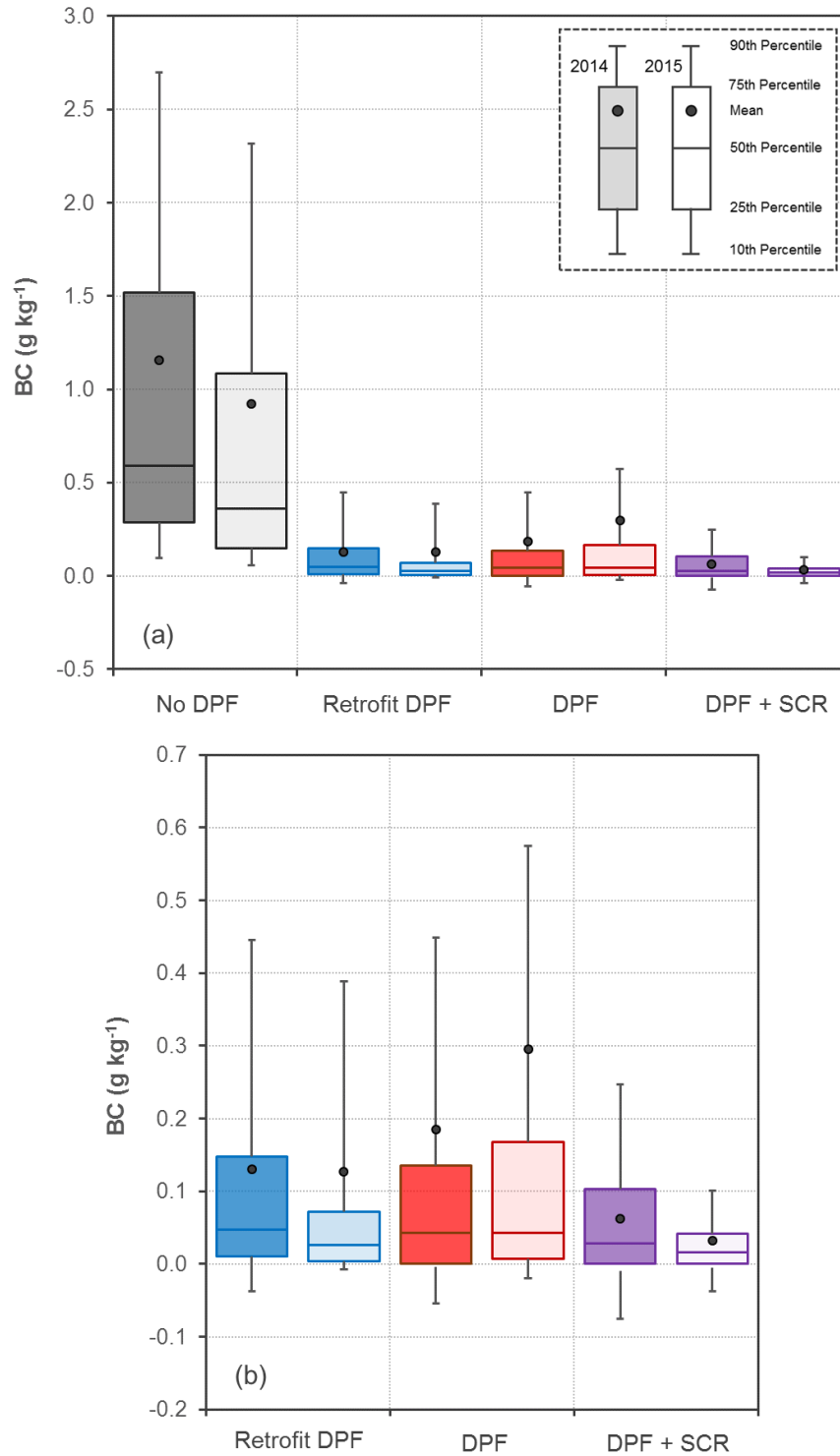

Figure 5.7 Distributions of BC emission factors by emission control category at the Caldecott Tunnel, as measured in 2014 and 2015. The top panel (a) shows the distributions for all four category types, while (b) shows the same data but only for the DPF-equipped categories.

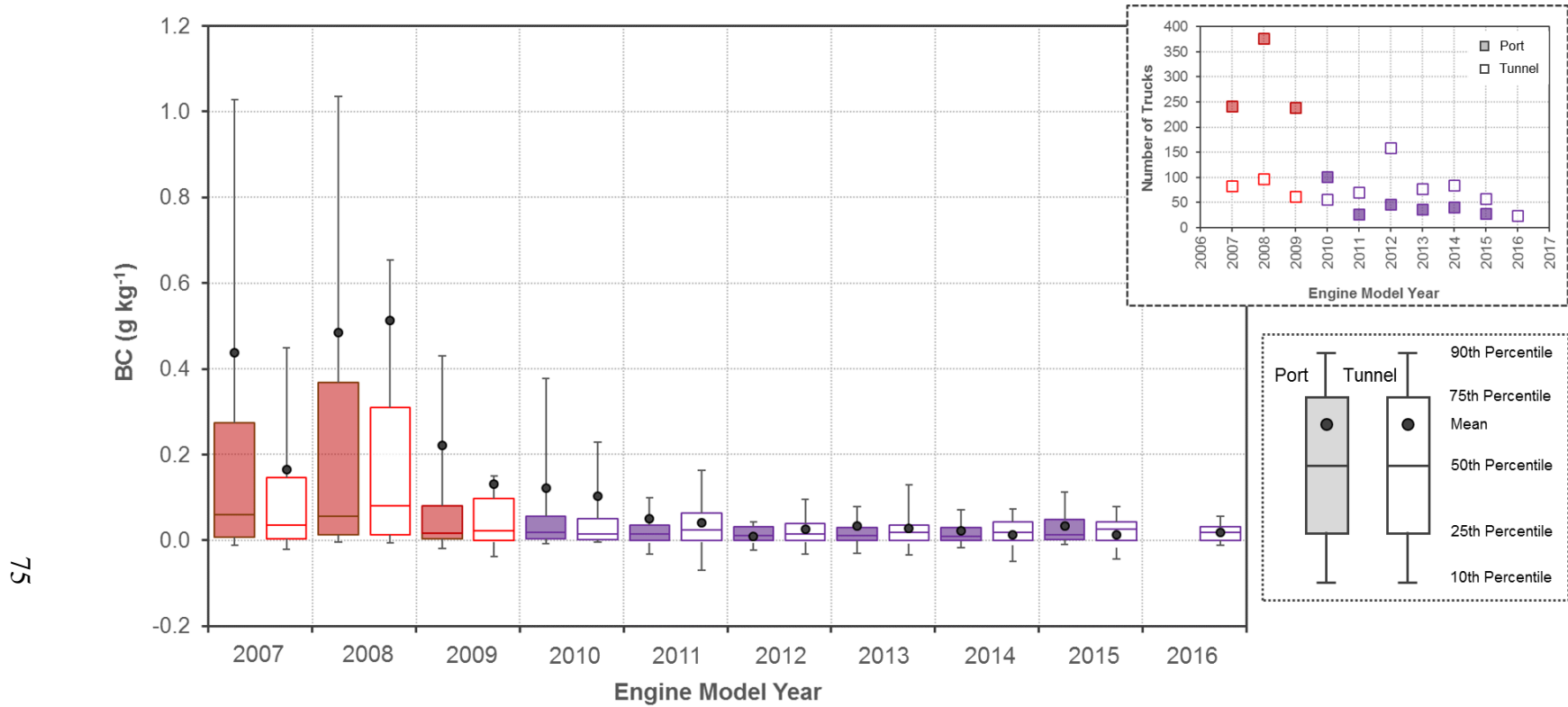

Figure 5.8 Distribution of measured BC emission factors by engine model year for trucks operating at the Port of Oakland and Caldecott Tunnel in 2015.

5.3 Conclusions

A number of observations point to the influence of driving mode on SCR functionality and particle number emission rates. With the higher engine load and temperatures experienced by trucks driving uphill at highway speeds at the Caldecott Tunnel, NO_x emissions by 2007–2009 trucks without SCR were nearly 40% higher on a per kg of fuel basis than the same category of drayage trucks observed at the Port of Oakland. Conversely, the same difference in driving conditions resulted in an average NO_x emission rate by 2010+ trucks that was 33% lower for the highway fleet. The uphill gradient and higher temperatures also increased the emission rate of N₂O by SCR-equipped trucks by more than a factor of 2.

Particle number emission rates by all categories of trucks were significantly higher under the highway driving conditions. Rather than the observed reduction in emitted PN by DPF-equipped drayage trucks traveling along the arterial street en route to the Port, original equipment DPFs did not affect the PN emission rate relative to trucks without filters but retrofit DPFs significantly increased the PN emission rate at the Caldecott Tunnel. The observed increase in emitted PN by retrofit DPFs was due to a significant increase in the emission rate of nucleation mode particles.

DPFs were equally effective at reducing BC emission rates at both sites, regardless of driving conditions. Both sites showed evidence of aging DPFs deteriorating on 2007–2009 trucks. The significance of these failing particle filters is greater in both occurrence rate and overall impact on fleet emissions at the Port of Oakland, although the mechanism for this difference by sampling location is not well understood. Further work is needed to understand why DPF systems on Port trucks are deteriorating or failing at such an unexpectedly high rate.

Chapter 6: Conclusions

6.1 Summary of Major Findings

Heavy-duty diesel truck exhaust emission rates were quantified at two San Francisco Bay Area locations: in 2011, 2013, and 2015 at the Port of Oakland and in 2014 and 2015 at the Caldecott Tunnel. The in-use emissions of several gas- and particle-phase pollutants from nearly 2300 individual drayage trucks operating at the Port of Oakland and more than 2300 individual trucks entering the Caldecott Tunnel were measured. Emission profiles from trucks were categorized by type of emission control technology by matching truck license plates to truck databases maintained by the state of California. The emission impacts and durability of diesel particle filters and selective catalytic reduction systems were evaluated. Moreover, the fleetwide emissions changes resulting from adoption of these after-treatment control technologies, accelerated by the Drayage Truck Regulation and Truck and Bus Regulation, were examined. Finally, the influence of driving mode on emissions by trucks equipped with these advanced after-treatment control systems was assessed by comparing the results from the two sampling locations.

Overall, DPF and SCR systems were very effective at reducing their target pollutants. On average, DPFs reduced emitted BC on a per kg of fuel burned basis by up to $94 \pm 32\%$ at the Port of Oakland and by up to $96 \pm 18\%$ at the Caldecott Tunnel (Table A3). SCR systems reduced the average NO_x emission rate by up to $76 \pm 7\%$ at the Port of Oakland and $86 \pm 6\%$ at the Caldecott Tunnel (Table A3). The greater effectiveness of SCR at the Tunnel is likely related to higher exhaust temperatures of trucks at that location, where travel speeds are higher and the 4% roadway grade is steeper than it is at the Port of Oakland. SCR systems on trucks on the arterial streets at the Port of Oakland may less frequently reach the minimum exhaust temperature required for effective reduction of NO_x to N_2 (Misra et al., 2013).

These two emission control technologies also affect the emission rates of co-emitted pollutant species. The intentional conversion of engine-out NO to NO_2 to passively regenerate DPFs increased tailpipe NO_2 emissions by up to a factor of 6 (Table A3). Trucks that were also equipped with SCR systems mitigated this DPF-related increase, however. At the Port of Oakland, SCR systems limited the average increase in primary NO_2 emissions to a factor of 2, whereas the more functional SCR systems at the Caldecott Tunnel resulted in no increase compared to trucks without particle filters (Table A3).

Conversely, the higher exhaust temperatures at the Tunnel more than doubled the average emission rate of N_2O by SCR-equipped trucks relative to the Port (Table A3). While N_2O is not an air pollutant of concern for public health, it is relevant in evaluating the global warming and ozone depletion potential of heavy-duty diesel truck emissions. Given that N_2O is a potent greenhouse gas with a 100-year global warming potential of 298 (IPCC, 2013) and has been identified as the dominant ozone-depleting substance currently emitted to the atmosphere

(Ravishankara et al., 2009), the on-road contribution to total emissions could become increasingly important as more heavy-duty diesel trucks equipped with SCR enter into service. For instance, on-road diesel contributed only 2% of statewide emissions of N₂O in California in 2014, and all sources of N₂O were responsible for only 2.8% of statewide greenhouse gas emissions on a CO₂-equivalent basis (CARB, 2016). As such, in the current greenhouse gas inventory for the state, N₂O emissions by on-road diesel contribute to less than 0.1% of total CO₂-equivalent emissions. If all trucks operating in the state that year were equipped with SCR, this fraction would only increase to 0.2–0.6% of the state’s greenhouse gas emissions, depending on the driving conditions chosen. However, the on-road diesel contribution to the statewide inventory of N₂O emissions would increase to 8–17%, raising the relevance of on-road diesel emissions from minor to on-par with certain agricultural contributions. Currently, agriculture accounts for 65% of N₂O emissions in California, with fertilizer application and decomposition of crop residue equal to 26%, manure added to soil contributing 25%, and manure management practices responsible for 12% of the total inventory (CARB, 2016). These back-of-the-envelope estimates assume statewide on-road diesel consumption as 2.6×10⁹ gallons of taxable diesel sold in 2014 (BOE, 2016), with the range of driving conditions represented by the DPF + SCR category-average N₂O emission factors reported in Table A3 for transient driving at the Port of Oakland (0.44 g kg⁻¹) and highway driving at the Caldecott Tunnel (1.00 g kg⁻¹). In summary, while N₂O emissions by heavy-duty diesel trucks are currently a negligible source of California’s statewide greenhouse gas emissions, their significance will increase as more trucks with SCR enter into service.

The influence of DPFs on emitted particle number was the most driving mode dependent. Average PN emissions at the Tunnel were 4–8 times the average values at the Port of Oakland, depending on the emission control category compared. The 2015 fleet-average PN emission factor at the Tunnel was greater than the fleet-average at the Port of Oakland by nearly a factor of 7. This trend towards higher magnitude PN emission rates indicate that increased exhaust temperature promotes increased ultrafine particle formation via nucleation. The emission rate of nucleation mode particles (<50 nm) by trucks with retrofit DPFs was more than 3 times higher than that of the other control categories (Figure 5.6). These driving mode dependencies for SCR functionality and DPF-related nucleation events have also been observed in other studies (Vaaraslahti et al., 2004; Biswas et al., 2009; Herner et al., 2011; Misra et al., 2013).

California’s Drayage Truck Regulation, which has been fully implemented, and Truck and Bus Regulation, which is currently being phased-in, have changed the composition of on-road truck fleets and their emissions. Between 2009 and 2015, the Port of Oakland truck fleet’s median engine age decreased from 11 to 7 years, the fraction of the fleet equipped with DPFs increased from 2 to 99%, and adoption of SCR increased from 0 to 25%. As a result of this modernization of the drayage fleet, average emission rates of NO_x, BC, and PN decreased by 70 ± 9%, 73 ± 22%, and 74 ± 27%, respectively. While universal adoption of DPFs after the first phase of the Drayage Truck Regulation had resulted in marked reductions in BC emissions, the fleet-average NO₂ emission rate more than doubled. The main effect of the second phase of the regulation was

to increase SCR use from 9 to 25% of the Port fleet, which further reduced NO_x emissions and partially mitigated the undesirable increase in fleet-average NO₂ emissions.

One concern associated with reliance of after-treatment control technologies to reduce truck emissions is performance deterioration with system aging, and thus increased emissions. This research provides some evidence of DPF deterioration. Between 2013 and 2015, use of DPFs to control particulate matter emissions was stable and near-universal for trucks at the Port of Oakland, but the fleet-average BC emission factor nevertheless increased by $12 \pm 35\%$. This unexpected increase was caused by a factor of 1.5 increase of the BC emission rate from 2007–2009 model year engines over the same period (Table A2). The same increase was observed at the Caldecott Tunnel between 2014 and 2015 (Figure 5.7). As a result, trucks with DPF system failures and/or other emissions-related malfunctions are now responsible for a majority of the BC emitted by the Port truck fleet (Figure 4.12). A recent study at the Port of Los Angeles has similarly identified decreasing performance over time by these 2007–2009 model year engines with DPFs (Haugen and Bishop, 2017), indicating that this issue is not limited to the fleets observed at the Port of Oakland and Caldecott Tunnel. Based on these findings, future efforts to reduce BC emissions should aim to improve durability/reduce the failure rate of installed emission control systems.

These studies offer a preview of changes expected from full implementation of the Truck and Bus Regulation on California's on-road fleet as well as from the national fleet of heavy-duty diesel trucks that is evolving with natural fleet turnover over. As more new trucks equipped with both DPF and SCR enter into service, the on-road diesel contribution to total NO_x and PM emissions will decline. There may be an increase in tailpipe NO₂ emissions with increased DPF adoption, which could influence ozone formation immediately downwind of major roadways and impact the respiratory health of those in the near-road environment. A recent health effects study, however, found evidence that DPFs on 2007 and newer engines significantly reduced the toxicity of diesel exhaust relative to the proven carcinogenicity of diesel exhaust from older engines without filters (HEI, 2015). By reducing diesel PM emissions and perhaps by altering the toxicity of emitted diesel exhaust (Herner et al., 2011; HEI, 2015), it is possible that the cancer risk due to air pollution from on-road heavy-duty diesel trucks will decline as more trucks are equipped with DPFs (BAAQMD, 2014). Such potential health impacts of cleaner truck fleets should be studied further. Elevated near-roadway NO₂ exposures may cause other health problems, including respiratory irritation, respiratory infections, and asthma (Linaker et al., 2000; Frampton et al., 2002; Costa et al., 2014). Even so, the decreased burden of PM and NO_x emissions achieved with widespread DPF and SCR use will likely greatly benefit those communities currently heavily impacted by diesel truck traffic.

6.2 Policy Implications and Recommendations for Future Research

In order to maintain the air quality benefits of advanced emission control systems over the in-use service life of heavy-duty diesel engines, improved filter durability and inspection and maintenance/repair programs may be needed. It is necessary to first understand why the performance of some diesel particle filters has deteriorated or failed after a relatively short period of in-use service.

Given that this deterioration appears to be mostly limited to DPFs that were installed on 2007–2009 model year engines at the time of manufacture, it is possible that filter age is the reason for deterioration. The warranty period for engines that meet the EPA’s 2007 emission standard is five years or 100,000 miles, while the useful life for these engines is rated at ten years or 435,000 miles (EPA, 2016). When deteriorating DPF performance by some 2007–2009 trucks was observed in 2015, these filters were six to eight years old and thus approaching the end of their useful life rating. The declining performance of these aging DPFs could also be the result of insufficient filter maintenance, in which incombustible ash slowly accumulates and fouls the filter substrate until the point of failure (Yang et al., 2016). While the rate of ash accumulation depends on engine lubricating oil consumption and operating conditions, the industry follows a minimum filter maintenance interval of every 150,000 miles (MECA, 2005). If improper filter cleaning is the primary cause of DPF deterioration, the failure rate for 2007–2009 DPFs may continue to increase over time and also expand to those filters on 2010 and newer engines.

Deterioration may be limited to DPFs installed on 2007–2009 model year engines. As the early adopters of this technology to meet the 2007 exhaust emission standard (Figure 1.1), the DPFs installed on 2007–2009 engines may not yet have been optimally designed for durability. Results from the Port of Oakland shown in Figure 4.10, in which most of the evidence for degradation over time is limited to DPFs on 2007 and 2008 model year engines, supports this hypothesis.

Differences in engine operating conditions may be a contributing factor: 2007–2009 engines without SCR are tuned towards higher engine-out PM in favor of lower engine-out NO_x (Misra et al., 2013). With this tuning, the engine is able to meet the 2007 NO_x emission limit (Figure 1.1), while the DPF is used to mitigate the high engine-out particle mass emission rate. These filters typically rely on active regeneration, given the heavier and more frequent filter duty cycle. Trucks with 2010+ engines, on the other hand, are operated in a different way, with higher engine-out NO_x and lower engine-out PM (Misra et al., 2013). The SCR systems are used to address the high engine-out NO_x emission rate, and the DPF can rely on passive regeneration given a much lower filter loading duty cycle. As such, it is possible that DPFs on 2007–2009 trucks experience over-demand in terms of heavier PM loading and more frequent/intense active regeneration events compared to the continuously regenerating DPFs with lower PM load on 2010+ engines. Operating strategies may not be enough to limit PM emissions from 2010+ engines as they get older, for example if lubricating oil consumption and engine-out PM emissions increase with engine age and wear.

Future work should explore possible explanations for DPF deterioration so as to better understand why system performance declines over time for at least some diesel particle filters. Additionally, more durable filter designs should be developed so that the particle mass reduction benefits observed in the present studies can be maintained over the lifetime of a truck, rather than for just ten years or less.

Additional efforts should also be made to expand the functional operating temperatures of SCR systems. The current minimum operational temperature required for SCR limits NO_x control to hot running engines. Emissions during cold starts and transient driving conditions have therefore become more important than hot exhaust, SCR-controlled emissions (Misra et al., 2013; Misra et al., 2016) This skewness not only alters the distribution of NO_x emitted in terms of engine duty cycles, but also the spatial distribution of where NO_x emissions are likely to occur. As more trucks equipped with SCR enter into service, we can expect to see more NO_x to be emitted where trucks are parked/re-started and operate under transient driving conditions rather than where engines are under high power-out demand.

From a policy standpoint, future work should focus on identifying and cleaning up the highest emitters that contribute a majority of emissions. Programs that assist truck owners with DPF and SCR system maintenance could ensure the long-term health of these control technologies on a truck-by-truck basis. Moreover, such programs could identify and then intervene to repair deteriorating control systems prior to complete failure. Such a maintenance and repair program could include a more automated version of the sampling methods employed in this dissertation research, such that emission rates of passing trucks are automatically quantified and high emitters can be identified and flagged for more detailed inspection and/or needed repairs.

In addition to policy changes, on-road emission studies should continue in parallel with ongoing modernization of the in-use truck fleet. On-road measurements like those presented in this research validate findings from laboratory-based dynamometer studies and can verify emission inventories. For instance, the Port of Oakland's newest emission inventory assumes an 82% reduction in emitted diesel PM between 2012 and 2015 (Ramboll Environ, 2016), whereas the BC reduction measured in this research over a similar period, between 2011 and 2015, was limited to $54 \pm 27\%$ (Table A2). This difference is due to the fact that the Port of Oakland emission inventory assumes all 2007 and newer engines meet the 2007 PM emission standard shown in Figure 1.1. As discussed in Chapter 4, however, BC emission rates for a small fraction of the 2015 drayage truck fleet exceed this limit by a large factor, and emissions from these trucks dominated total BC emissions from the overall truck fleet. The importance of such malfunctioning emission control technologies already appears to not be adequately recognized.

Whereas this dissertation research verifies that advanced emission control technologies clearly and substantially control particle mass and nitrogen oxide emissions, neglecting the observed increases in emissions of other co-emitted pollutants and the occurrence of high emitters in the on-road truck fleet can lead to overstating the benefits of increasingly stringent emission standards for new engines and regulations to accelerate fleet turnover.

References

- BAAQMD, 2009. West Oakland Truck Survey. [http://www.baaqmd.gov/~media/Files/Planning and Research/CARE Program/Final West Oakland Truck Survey Report Dec 2009.ashx?la=en](http://www.baaqmd.gov/~media/Files/Planning%20and%20Research/CARE%20Program/Final%20West%20Oakland%20Truck%20Survey%20Report%20Dec%202009.ashx?la=en)
- BAAQMD, 2014. Improving Air Quality & Health in Bay Area Communities: Community Air Risk Evaluation (CARE) Program Retrospective & Path Forward (2004-2013). [http://www.baaqmd.gov/~media/Files/Planning and Research/CARE Program/Documents/CARE_Retrospective_April2014.ashx?la=en](http://www.baaqmd.gov/~media/Files/Planning%20and%20Research/CARE%20Program/Documents/CARE_Retrospective_April2014.ashx?la=en)
- Ban-Weiss, G.A., McLaughlin, J.P., Harley, R.A., Lunden, M.M., Kirchstetter, T.W., Kean, A.J., Strawa, A.W., Stevenson, E.D., Kendall, G.R., 2008. Long-term changes in emissions of nitrogen oxides and particulate matter from on-road gasoline and diesel vehicles. *Atmos. Environ.* 42, 220–232. doi:10.1016/j.atmosenv.2007.09.049
- Ban-Weiss, G.A., Lunden, M.M., Kirchstetter, T.W., Harley, R.A., 2009. Measurement of black carbon and particle number emission factors from individual heavy-duty trucks. *Environ. Sci. Technol.* 43, 1419–1424. doi:10.1021/es8021039
- Barone, T.L., Storey, J.M.E., Domingo, N., 2010. An analysis of field-aged diesel particulate filter performance: Particle emissions before, during, and after regeneration. *J. Air Waste Manage. Assoc.* 60, 968–976. doi:10.3155/1047-3289.60.8.968
- Bishop, G.A., Schuchmann, B.G., Stedman, D.H., Lawson, D.R., 2012. Emission changes resulting from the San Pedro Bay, California ports truck retirement program. *Environ. Sci. Technol.* 46, 551–558. doi:10.1021/es202392g
- Bishop, G.A., Schuchmann, B.G., Stedman, D.H., 2013. Heavy-duty truck emissions in the south coast air basin of California. *Environ. Sci. Technol.* 47, 9523–9529. doi:10.1021/es401487b
- Bishop, G.A., Hottor-Raguindin, R., Stedman, D.H., McClintock, P., Theobald, E., Johnson, J.D., Lee, D.-W., Zietsman, J., Misra, C., 2015. On-road heavy-duty vehicle emissions monitoring system. *Environ. Sci. Technol.* 49, 1639–1645. doi:10.1021/es505534e
- Biswas, S., Hu, S., Verma, V., Herner, J.D., Robertson, W.H., Ayala, A., Sioutas, C., 2008. Physical properties of particulate matter (PM) from late model heavy-duty diesel vehicles operating with advanced PM and NO_x emission control technologies. *Atmos. Environ.* 42, 5622–5634. doi:10.1016/j.atmosenv.2008.03.007
- Biswas, S., Verma, V., Schauer, J.J., Sioutas, C., 2009. Chemical speciation of PM emissions from heavy-duty diesel vehicles equipped with diesel particulate filter (DPF) and selective catalytic reduction (SCR) retrofits. *Atmos. Environ.* 43, 1917–1925. doi:10.1016/j.atmosenv.2008.12.040

- BOE, 2016. Taxable Diesel Gallons 10 Year Report.
https://www.boe.ca.gov/sptaxprog/reports/Diesel_10_Year_Report.pdf
- Bond, T.C., Doherty, S.J., Fahey, D.W., Forster, P.M., Berntsen, T., Deangelo, B.J., Flanner, M.G., Ghan, S., Kärcher, B., Koch, D., Kinne, S., Kondo, Y., Quinn, P.K., Sarofim, M.C., Schultz, M.G., Schulz, M., Venkataraman, C., Zhang, H., Zhang, S., Bellouin, N., Guttikunda, S.K., Hopke, P.K., Jacobson, M.Z., Kaiser, J.W., Klimont, Z., Lohmann, U., Schwarz, J.P., Shindell, D., Storelvmo, T., Warren, S.G., Zender, C.S., 2013. Bounding the role of black carbon in the climate system: A scientific assessment. *J. Geophys. Res. Atmos.* 118, 5380–5552. doi:10.1002/jgrd.50171
- Brugge, D., Durant, J.L., Rioux, C., 2007. Near-highway pollutants in motor vehicle exhaust: a review of epidemiologic evidence of cardiac and pulmonary health risks. *Environ. Health* 6, 23. doi:10.1186/1476-069X-6-23
- CARB, 1998. Findings of the Scientific Review Panel on the Report on Diesel Exhaust.
<https://www.arb.ca.gov/toxics/dieseltac/de-fnds.htm>
- CARB, 2011. Overview of the Statewide Drayage Truck Regulation.
<http://www.arb.ca.gov/msprog/onroad/porttruck/regfactsheet.pdf>
- CARB, 2013. The California Almanac of Emissions and Air Quality (2013 Edition).
<https://www.arb.ca.gov/aqd/almanac/almanac13/almanac2013all.pdf>
- CARB, 2014a. Truck and Bus Regulation Compliance Requirements Summary.
<https://www.arb.ca.gov/msprog/onrdiesel/documents/FSRegSum.pdf>
- CARB, 2014b. Final Regulation Order for Phase 1 Greenhouse Gas Regulations.
<https://www.arb.ca.gov/regact/2013/hdghg2013/hdghgfrot13.pdf>
- CARB, 2015. Short Lived Climate Pollutant Black Carbon Emission Inventory.
https://www.arb.ca.gov/cc/inventory/slcp/data/slcp_bc_20yr1.pdf
- CARB, 2016. California Greenhouse Gas Emission Inventory - 2016 Edition.
<https://www.arb.ca.gov/cc/inventory/data/data.htm>
- CARB, 2017. Short-Lived Climate Pollutant Reduction Strategy.
https://www.arb.ca.gov/cc/shortlived/meetings/03142017/final_slcp_report.pdf
- Costa, S., Ferreira, J., Silveira, C., Costa, C., Lopes, D., Relvas, H., Borrego, C., Roebeling, P., Miranda, A.I., Teixeira, J.P., 2014. Integrating health on air quality assessment—review report on health risks of two major European outdoor air pollutants: PM and NOx. *J. Toxicol. Environ. Health. B. Crit. Rev.* 17, 307–40. doi:10.1080/10937404.2014.946164

- Dallmann, T.R., Harley, R.A., 2010. Evaluation of mobile source emission trends in the United States. *J. Geophys. Res.* 115, D14305. doi:10.1029/2010JD013862
- Dallmann, T.R., Harley, R.A., Kirchstetter, T.W., 2011. Effects of diesel particle filter retrofits and accelerated fleet turnover on drayage truck emissions at the Port of Oakland. *Environ. Sci. Technol.* 45, 10773–10779. doi:10.1021/es202609q
- Dallmann, T.R., DeMartini, S.J., Kirchstetter, T.W., Herndon, S.C., Onasch, T.B., Wood, E.C., Harley, R.A., 2012. On-road measurement of gas and particle phase pollutant emission factors for individual heavy-duty diesel trucks. *Environ. Sci. Technol.* 46, 8511–8518. doi:10.1021/es301936c
- EPA, 2016. Heavy-Duty Highway Compression-Ignition Engines And Urban Buses: Exhaust Emission Standards. <https://nepis.epa.gov/Exe/ZyPDF.cgi?Dockkey=P10009ZZ.pdf>
- Frampton, M.W., Boscia, J., Roberts, N.J., Azadniv, M., Torres, A., Cox, C., Morrow, P.E., Nichols, J., Chalupa, D., Frasier, L.M., Gibb, F.R., Speers, D.M., Tsai, Y., Utell, M.J., 2002. Nitrogen dioxide exposure: effects on airway and blood cells. *Am. J. Physiol. Lung Cell. Mol. Physiol.* 282, L155–L165.
- Franklin, L.M., Bika, A.S., Watts, W.F., Kittelson, D.B., 2010. Comparison of water and butanol based CPCs for examining diesel combustion aerosols. *Aerosol Sci. Technol.* 44, 629–638. doi:10.1080/02786826.2010.482112
- Hallstrom, K., Voss, K.E., Corp, B., 2013. The Formation of N₂O on the SCR Catalyst in a Heavy Duty US 2010 Emission Control System. *SAE Int.* doi:10.4271/2013-01-2463
- Haugen, M.J., Bishop, G.A., 2017. Repeat Fuel Specific Emission Measurements on Two California Heavy-Duty Truck Fleets. *Environ. Sci. Technol.* 51, 4100–4107. doi:10.1021/acs.est.6b06172
- Havenith, C., Verbeek, R.P., 1997. Transient Performance of a Urea deNO_x Catalyst for Low Emissions Heavy-Duty Diesel Engines. *SAE Tech. Pap.* 970185. doi:10.4271/970185
- HEI, 2015. The Advanced Collaborative Emissions Study (ACES). https://www.healtheffects.org/system/files/ACES-Executive-Summary2015_0.pdf
- Herner, J.D., Hu, S., Robertson, W.H., Huai, T., Collins, J.F., Dwyer, H., Ayala, A., 2009. Effect of advanced aftertreatment for PM and NO_x control on heavy-duty diesel truck emissions. *Environ. Sci. Technol.* 43, 5928–5933. doi:10.1021/es9008294
- Herner, J.D., Hu, S., Robertson, W.H., Huai, T., Chang, M.C.O., Rieger, P., Ayala, A., 2011. Effect of advanced aftertreatment for PM and NO_x reduction on heavy-duty diesel engine ultrafine particle emissions. *Environ. Sci. Technol.* 45, 2413–2419. doi:10.1021/es102792y

- Heywood, J.R., 1988. *Internal Combustion Engine Fundamentals*. McGraw-Hill Inc., New York, NY.
- IARC, 2012. Diesel engine exhaust carcinogenic. Lyon, France. http://www.iarc.fr/en/media-centre/pr/2012/pdfs/pr213_E.pdf
- IPCC, 2013. Chapter 8: Anthropogenic and Natural Radiative Forcing, *Climate Change 2013: The Physical Science Basis. Contribution of Working Group I to the Fifth Assessment Report of the Intergovernmental Panel on Climate Change*. Cambridge University Press, Cambridge, United Kingdom and New York, NY, USA. doi:10.1017/CBO9781107415324.018
- Jeong, C.-H., Evans, G.J., 2009. Inter-comparison of a fast mobility particle sizer and a scanning mobility particle sizer incorporating an ultrafine water-based condensation particle counter. *Aerosol Sci. Technol.* 43, 364–373. doi:10.1080/02786820802662939
- Kebabian, P.L., Wood, E.C., Herndon, S.C., Freedman, A., 2008. A practical alternative to chemiluminescence-based detection of nitrogen dioxide: Cavity attenuated phase shift spectroscopy. *Environ. Sci. Technol.* 42, 6040–6045. doi:10.1021/es703204j
- Kirchstetter, T.W., Novakov, T., 2007. Controlled generation of black carbon particles from a diffusion flame and applications in evaluating black carbon measurement methods. *Atmos. Environ.* 41, 1874–1888. doi:10.1016/j.atmosenv.2006.10.067
- Kittelson, D.B., 1998. Engines and nanoparticles: A review. *J. Aerosol Sci.* 29, 575–588. doi:10.1016/S0021-8502(97)10037-4
- Koebel, M., Elsener, M., Madia, G., 2001. Recent Advances in the Development of Urea-SCR for Automotive Applications. SAE Tech. Pap. 2001-01-3625.
- Koebel, M., Madia, G., Elsener, M., 2002. Selective catalytic reduction of NO and NO₂ at low temperatures. *Catal. Today* 73, 239–247. doi:10.1016/S0920-5861(02)00006-8
- Linaker, C.H., Coggon, D., Holgate, S.T., Clough, J., Josephs, L., Chauhan, A.J., Inskip, H.M., 2000. Personal exposure to nitrogen dioxide and risk of airflow obstruction in asthmatic children with upper respiratory infection. *Thorax* 55, 930–933. doi:10.1136/thorax.55.11.930
- Liu, Z., Swanson, J., Kittelson, D.B., Pui, D.Y.H., 2012. Comparison of methods for online measurement of diesel particulate matter. *Environ. Sci. Technol.* 46, 6127–6133. doi:10.1021/es3003537
- Lloyd, A.C., Cackette, T.A., 2001. Diesel engines: Environmental impact and control. *J. Air Waste Manage. Assoc.* 51, 809–847. doi:10.1080/10473289.2001.10464315

- McClellan, R.O., 1987. Health effects of exposure to diesel exhaust particles. *Ann. Rev. Pharmacol. Toxicol.* 27, 279–300.
- McDonald, B.C., Goldstein, A.H., Harley, R.A., 2015. Long-term trends in California mobile source emissions and ambient concentrations of black carbon and organic aerosol. *Environ. Sci. Technol.* 49, 5178–5188. doi:10.1021/es505912b
- MECA, 2005. Diesel Particulate Filter Maintenance: Current Practices and Experience. Washington, D.C.
http://www.meca.org/galleries/files/filter_maintenance_white_paper_605_final.pdf
- Misra, C., Collins, J.F., Herner, J.D., Sax, T., Krishnamurthy, M., Sobieralski, W., Burntitzki, M., Chernich, D., 2013. In-use NO_x emissions from model year 2010 and 2011 heavy-duty diesel engines equipped with aftertreatment devices. *Environ. Sci. Technol.* 47, 7892–7898. doi:10.1021/es4006288
- Misra, C., Collins, J., Chernich, D., Herner, J., 2017. In-use NO_x emissions from diesel and liquefied natural gas refuse trucks equipped with SCR and TWC respectively. *Environ. Sci. Technol.* doi: 10.1021/acs.est.6b03218
- Morawska, L., Ristovski, Z., Jayaratne, E.R., Keogh, D.U., Ling, X., 2008. Ambient nano and ultrafine particles from motor vehicle emissions: Characteristics, ambient processing and implications on human exposure. *Atmos. Environ.* 42, 8113–8138. doi:10.1016/j.atmosenv.2008.07.050
- Oberdörster, G., 2001. Pulmonary effects of inhaled ultrafine particles. *Int. Arch. Occup. Environ. Health* 74, 1–8. doi:10.1007/s004200000185
- Ostro, B., Hu, J., Goldbery, D., Reynolds, P., Hertz, A., Bernstein, L., Kleeman, M.J., 2015. Associations of mortality with long-term exposures to fine and ultrafine particles, species and sources: Results from the California teachers study cohort. *Environ. Health Perspect.* 123, 549–556. doi:10.1289/ehp.1408565
- Preble, C. V., Dallmann, T.R., Kreisberg, N.M., Hering, S. V., Harley, R.A., Kirchstetter, T.W., 2015. Effects of particle filters and selective catalytic reduction on heavy-duty diesel drayage truck emissions at the Port of Oakland. *Environ. Sci. Technol.* 49, 8864–8871. doi:10.1021/acs.est.5b01117
- Quiros, D.C., Yoon, S., Dwyer, H.A., Collins, J.F., Zhu, Y., Huai, T., 2014. Measuring particulate matter emissions during parked active diesel particulate filter regeneration of heavy-duty diesel trucks. *J. Aerosol Sci.* 73, 48–62. doi:10.1016/j.jaerosci.2014.03.002

- Quiros, D.C., Hu, S., Hu, S., Lee, E.S., Sardar, S., Wang, X., Olfert, J.S., Jung, H.S., Zhu, Y., Huai, T., 2015. Particle effective density and mass during steady-state operation of GDI, PFI, and diesel passenger cars. *J. Aerosol Sci.* 83, 39–54. doi:10.1016/j.jaerosci.2014.12.004
- Ramanathan, V., Bahadur, R., Praveen, P.S., Prather, K.A., Cazorla, A., Kirchstetter, T., Hadley, O.L., Leung, R., Zhao, C., 2013. Black Carbon and the Regional Climate of California: Report to the California Air Resources Board, Contract 08-323. <http://www.arb.ca.gov/research/rsc/3-8-13/item8dfr08-323.pdf>
- Ramboll Environ, 2016. Port of Oakland 2015 Seaport Air Emissions Inventory, Final Report. <http://www.portofoakland.com/files/PDF/Port of Oakland 2015 Seaport Emissions Inventory Final-11Oct2016.pdf>
- Ravishankara, A.R., Daniel, J.S., Portmann, R.W., 2009. Nitrous oxide (N₂O): the dominant ozone-depleting substance emitted in the 21st century. *Science* 326, 123–125. doi:10.1126/science.1176985
- Shorter, J.H., Herndon, S., Zahniser, M.S., Nelson, D.D., Wormhoudt, J., Demerjian, K.L., Kolb, C.E., 2005. Real-time measurements of nitrogen oxide emissions from in-use New York City transit buses using a chase vehicle. *Environ. Sci. Technol.* 39, 7991–8000. doi:10.1021/es048295u
- Sioutas, C., Delfino, R.J., Singh, M., 2005. Exposure assessment for atmospheric ultrafine particles (UFPs) and implications in epidemiologic research. *Environ. Health Perspect.* 113, 947–955. doi:10.1289/ehp.7939
- Sluder, S.C., Storey, J.M.E., Lewis, S.A., Lewis, L.A., 2005. Low Temperature Urea Decomposition and SCR Performance. SAE Tech. Pap. 2005-01-1858. doi:10.4271/2005-01-1858
- Vaaraslahti, K., Virtanen, A., Ristimäki, J., Keskinen, J., 2004. Nucleation mode formation in heavy-duty diesel exhaust with and without a particulate filter. *Environ. Sci. Technol.* 38, 4884–4890. doi:10.1021/es0353255
- van Setten, B.A.A.L., Makkee, M., Moulijn, J.A., 2001. Science and technology of catalytic diesel particulate filters. *Catal. Rev.* 43, 489–564.
- Yang, K., Fox, J.T., Hunsicker, R., 2016. Characterizing Diesel Particulate Filter Failure During Commercial Fleet Use due to Pinholes, Melting, Cracking, and Fouling. *Emiss. Control Sci. Technol.* 2, 145–155. doi:10.1007/s40825-016-0036-0
- Zimmerman, N., Pollitt, K.J.G., Jeong, C.-H., Wang, J.M., Jung, T., Cooper, J.M., Wallace, J.S., Evans, G.J., 2014. Comparison of three nanoparticle sizing instruments: The influence of particle morphology. *Atmos. Environ.* 86, 140–147. doi:10.1016/j.atmosenv.2013.12.023

Appendix

Table A1. Average emission factors (\pm 95% confidence intervals) of the duplicate measures of NO₂, duplicate measures of fine PM, and first-time measurements of N₂O for the drayage truck fleet as measured only in 2015 at the Port of Oakland and characterized by emission control technology and engine model year.

Sampling Year	Fleet or Truck Category	Range of Engine Model Years	Median Engine Model Year	Number of Trucks	NO ₂ by Difference (g kg ⁻¹)	NO ₂ Direct (g kg ⁻¹)	Fine PM, DustTrak (g kg ⁻¹)	Fine PM, DMM (g kg ⁻¹)	N ₂ O (g kg ⁻¹)
2015	Fleet (99% DPF, 25% SCR)	1996–2016	2008	1095–1218	2.20 ± 0.19	2.45 ± 0.20	0.34 ± 0.11	0.22 ± 0.04	0.16 ± 0.03
	No DPF	1996–2006	2005	10–11	2.08 ± 0.90	2.46 ± 1.06	0.67 ± 0.56	0.33 ± 0.36	0.07 ± 0.06
	Retrofit DPF	N/A							
	DPF	2007–2009	2008	811–903	2.53 ± 0.22	2.87 ± 0.24	0.42 ± 0.15	0.26 ± 0.05	0.06 ± 0.01
	DPF + SCR	2010–2016	2012	274–304	1.22 ± 0.34	1.23 ± 0.32	0.10 ± 0.09	0.07 ± 0.05	0.44 ± 0.11

Table A2. Average emission factors (\pm 95% confidence intervals) for the drayage truck fleet characterized by emission control technology and engine model year, as measured in 2009, 2011, 2013, and 2015 at the Port of Oakland. NO₂ results are reported for the *by difference* method, fine PM results are derived from the uncalibrated DustTrak measurements, and PN results are from the butanol-based ultrafine condensation particle counter.

Sampling Year	Fleet or Truck Category	Range of Engine Model Years	Median Engine Model Year	Number of Trucks	NO _x (g kg ⁻¹)	NO ₂ (g kg ⁻¹)	NO ₂ /NO _x Emission Ratio	BC (g kg ⁻¹)	Fine PM (g kg ⁻¹)	PN (10 ¹⁵ particles kg ⁻¹)
2009	Fleet (2% DPF, 0% SCR)	1970–2009	1997	169–172	32.6 ± 2.3	1.11 ± 0.58	0.03 ± 0.02	1.15 ± 0.19	1.25 ± 0.23	3.9 ± 0.8
2011	Fleet (54% DPF, 2% SCR)	1994–2011	2004	363–368	18.0 ± 1.2	2.09 ± 0.40	0.12 ± 0.02	0.67 ± 0.14	0.76 ± 0.22	2.6 ± 0.5
	No DPF	2004–2006	2005	166–174	15.9 ± 1.7	0.51 ± 0.30	0.03 ± 0.02	1.12 ± 0.28	1.28 ± 0.45	3.3 ± 0.7
	Retrofit DPF	1994–2003	1999	119–124	23.0 ± 1.2	3.39 ± 0.50	0.15 ± 0.02	0.26 ± 0.09	0.34 ± 0.14	1.4 ± 0.8
	DPF	2007–2009	2008	70–75	15.0 ± 3.6	3.48 ± 1.50	0.23 ± 0.11	0.31 ± 0.11	0.25 ± 0.11	3.0 ± 1.6
	DPF + SCR	2010–2011	2001	5–6	10.2 ± 3.8	3.77 ± 1.40	0.37 ± 0.19	0.44 ± 0.41	0.20 ± 0.30	1.1 ± 1.6

2013	Fleet (99% DPF, 9% SCR)	1994– 2013	2007	934– 1005	15.4 ± 0.9	2.84 ± 0.22	0.18 ± 0.02	0.28 ± 0.05	0.26 ± 0.05	2.0 ± 0.4
	No DPF	2004– 2006	2005	14–15	24.0 ± 7.7	1.12 ± 0.81	0.05 ± 0.04	1.01 ± 0.54	1.18 ± 0.61	10.6 ± 5.4
	Retrofit DPF	1994– 2006	1998	258–281	27.3 ± 1.9	4.14 ± 0.50	0.15 ± 0.02	0.34 ± 0.08	0.39 ± 0.09	2.0 ± 0.6
	DPF	2007– 2009	2008	581–626	11.5 ± 0.9	2.58 ± 0.25	0.22 ± 0.03	0.26 ± 0.06	0.21 ± 0.06	1.9 ± 0.5
	DPF + SCR	2010– 2013	2011	81–94	4.9 ± 1.2	1.00 ± 0.32	0.20 ± 0.08	0.06 ± 0.02	0.07 ± 0.04	1.0 ± 0.6
2015	Fleet (99% DPF, 25% SCR)	1996– 2016	2008	1194– 1218	9.9 ± 0.6	2.20 ± 0.19	0.22 ± 0.02	0.31 ± 0.09	0.34 ± 0.11	1.0 ± 0.3
	No DPF	1996– 2006	2005	10–11	11.5 ± 4.8	2.08 ± 0.90	0.18 ± 0.11	0.56 ± 0.50	0.67 ± 0.56	0.7 ± 0.3
	Retrofit DPF	N/A								
	DPF	2007– 2009	2008	871–903	11.0 ± 0.7	2.53 ± 0.22	0.23 ± 0.02	0.39 ± 0.11	0.42 ± 0.15	1.1 ± 0.3
	DPF + SCR	2010– 2016	2012	286–304	6.4 ± 1.2	1.22 ± 0.34	0.19 ± 0.06	0.06 ± 0.03	0.10 ± 0.09	0.8 ± 0.3

Table A3. Fleet-average emission factors (\pm 95% confidence intervals) for the Port of Oakland truck fleet in 2015 (reproduced from Table A2 above) and Caldecott Tunnel truck fleets in 2014 and 2015, as well as average emission factors characterized by emission control technology at each location. The category-average values are from the combined 2011, 2013, and 2015 measurements at the Port of Oakland and from the combined 2014 and 2015 measurements at the Caldecott Tunnel. NO₂ results are reported for the *by difference* method and PN results are from the butanol-based ultrafine condensation particle counter.

Sampling Location	Fleet or Truck Category	Range of Engine Model Years	Median Engine Model Year	Number of Trucks	NO _x (g kg ⁻¹)	NO ₂ (g kg ⁻¹)	NO ₂ /NO _x Emission Ratio	BC (g kg ⁻¹)	PN (10 ¹⁵ particles kg ⁻¹)	N ₂ O (g kg ⁻¹)
Port of Oakland	2015 Fleet (99% DPF, 25% SCR)	1996–2016	2008	1194–1218	9.9 \pm 0.6	2.20 \pm 0.19	0.22 \pm 0.02	0.31 \pm 0.09	1.0 \pm 0.3	0.16 \pm 0.03
	No DPF	1996–2006	2005	192–199	16.3 \pm 1.6	0.64 \pm 0.28	0.04 \pm 0.02	1.08 \pm 0.25	3.7 \pm 0.8	N/A
	Retrofit DPF	1994–2006	1999	379–399	26.0 \pm 1.4	3.91 \pm 0.38	0.15 \pm 0.02	0.32 \pm 0.06	1.8 \pm 0.5	N/A
	DPF	2007–2009	2008	886–1598	11.4 \pm 0.6	2.60 \pm 0.17	0.23 \pm 0.02	0.33 \pm 0.07*	1.5 \pm 0.3	0.06 \pm 0.01
	DPF + SCR	2010–2016	2012	300–403	6.1 \pm 0.9	1.20 \pm 0.27	0.20 \pm 0.05	0.07 \pm 0.02	0.8 \pm 0.3	0.44 \pm 0.11

*Note: this average BC emission rate includes the apparent DPF deterioration over time (2011 + 2013 average = 0.26 \pm 0.06 g kg⁻¹ versus 2015 average = 0.39 \pm 0.11 g kg⁻¹).

Sampling Location	Fleet or Truck Category	Range of Engine Model Years	Median Engine Model Year	Number of Trucks	NO _x (g kg ⁻¹)	NO ₂ (g kg ⁻¹)	NO ₂ /NO _x Emission Ratio	BC (g kg ⁻¹)	PN (10 ¹⁵ particles kg ⁻¹)	N ₂ O (g kg ⁻¹)
Caldecott Tunnel	2014 Fleet (72% DPF, 33% SCR)	1965–2015	2008	1070–1139	16.3 ± 0.9	1.84 ± 0.19	0.11 ± 0.01	0.41 ± 0.06	7.5 ± 0.7	0.25 ± 0.06
	2015 Fleet (80% DPF, 46% SCR)	1979–2016	2009	1089–1194	15.0 ± 0.9	1.84 ± 0.17	0.12 ± 0.01	0.28 ± 0.06	6.9 ± 0.5	0.55 ± 0.14
	No DPF	1965–2007	1999	531–561	29.9 ± 1.3	0.95 ± 0.15	0.03 ± 0.01	1.06 ± 0.13	6.8 ± 0.7	0.00 ± 0.07
	Retrofit DPF	1994–2009	2002	224–245	26.3 ± 1.5	2.86 ± 0.45	0.11 ± 0.02	0.13 ± 0.04	11.6 ± 1.4	0.00 ± 0.02
	DPF	2007–2009	2008	566–601	15.9 ± 0.8	3.81 ± 0.33	0.24 ± 0.02	0.23 ± 0.08*	6.4 ± 0.9	0.01 ± 0.02
	DPF + SCR	2010–2016	2012	838–926	4.1 ± 0.4	0.83 ± 0.11	0.20 ± 0.03	0.04 ± 0.01	6.7 ± 0.7	1.00 ± 0.19

*Note: this average BC emission rate includes the apparent DPF deterioration over time (2014 average = 0.18 ± 0.07 g kg⁻¹ versus 2015 average = 0.30 ± 0.16 g kg⁻¹).