

UCLA

UCLA Previously Published Works

Title

Application of concave up p-y elements in static analysis of piles in laterally spreading ground.

Permalink

<https://escholarship.org/uc/item/38d6h11k>

Authors

Brandenberg, SJ
Kashighandi, P.

Publication Date

2022-12-16

Peer reviewed



May 24th - May 29th

Application Of Concave-Up P-Y Elements In Static Analysis Of Piles In Laterally Spreading Ground

Pirooz Kashighandi

University of California, Los Angeles, CA 90095-1593

Scott J. Brandenburg

University of California, Los Angeles, CA 90095-1593

Follow this and additional works at: <http://scholarsmine.mst.edu/icrageesd>

Recommended Citation

Pirooz Kashighandi and Scott J. Brandenburg, "Application Of Concave-Up P-Y Elements In Static Analysis Of Piles In Laterally Spreading Ground" (May 24, 2010). *International Conferences on Recent Advances in Geotechnical Earthquake Engineering and Soil Dynamics*. Paper 2.

<http://scholarsmine.mst.edu/icrageesd/05icrageesd/session09/2>

This Article - Conference proceedings is brought to you for free and open access by Scholars' Mine. It has been accepted for inclusion in International Conferences on Recent Advances in Geotechnical Earthquake Engineering and Soil Dynamics by an authorized administrator of Scholars' Mine. This work is protected by U. S. Copyright Law. Unauthorized use including reproduction for redistribution requires the permission of the copyright holder. For more information, please contact scholarsmine@mst.edu.



APPLICATION OF CONCAVE-UP P-Y ELEMENTS IN STATIC ANALYSIS OF PILES IN LATERALLY SPREADING GROUND

Piروز Kashighandi

Dept. of Civil and Environ. Eng.
University of California
Los Angeles, CA 90095-1593

Scott J. Brandenberg

Dept. of Civil and Environ. Eng.
University of California
Los Angeles, CA 90095-1593

ABSTRACT

Concave-up p-y behavior in liquefied sand has been observed by many researchers due to the dilatant tendency of sand that is dense of its critical state being suppressed in undrained loading. However, static analysis method often scale down the concave-down p-y curves that characterize drained loading, thereby missing the potentially important influence of concave-up behavior on pile response. For lateral spreading problems, large shear strains are typically assigned to the liquefied layer, which presupposes that the liquefied sand is soft and weak. This assumption is incompatible with the strengthening, stiffening concave-up p-y material. This paper presents a static lateral spreading analysis of a pile using concave-up p-y materials to demonstrate how this incompatibility can lead to unrealistic results.

INTRODUCTION

A number of research studies have shown that p-y behavior in liquefied sand exhibits a concave-up, inverted S-shaped behavior that is also characteristic of the stress-strain response of sand in undrained cyclic loading. Wilson et al. (2000) demonstrated that liquefied medium dense sand could exert larger subgrade reaction forces than predicted by the drained API (1993) relations for piles in sand (Fig. 1). This is contrary to the common expectation that liquefied sand is soft and weak, and that p-y behavior must therefore be much

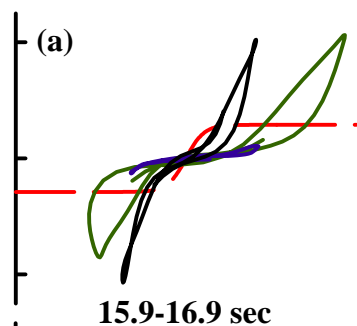

Figure 1: p-y behavior recorded during a centrifuge model of a pile in liquefied medium-dense sand (Wilson et al. 2000). The red line shows the drained API (1993) sand relation.

weaker in liquefied ground than in non-liquefied ground. This behavior was subsequently verified by static load tests (e.g. Ashford Rollins 2002; Fig. 2) and numerical simulations (e.g., Iai 2002; Fig. 3). In all three cases shown herein, the p-y behavior exhibited a displacement-hardening response in which the tangent modulus increased as displacement increased. This hardening response is often called concave-up

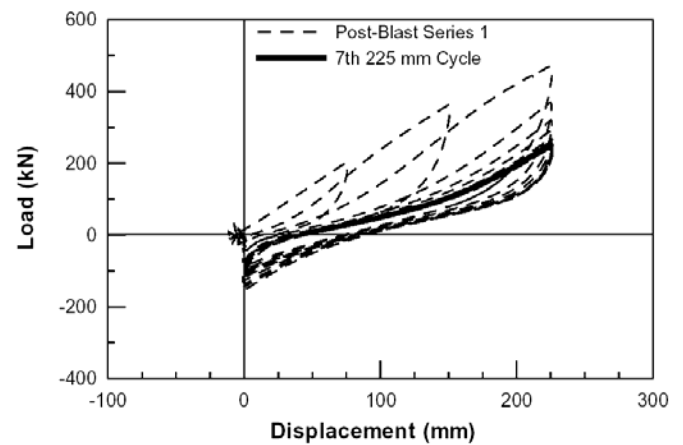

Figure 2: p-y behavior recorded during a static load test of a pile in liquefied medium-dense sand (Ashford and Rollins 2002).

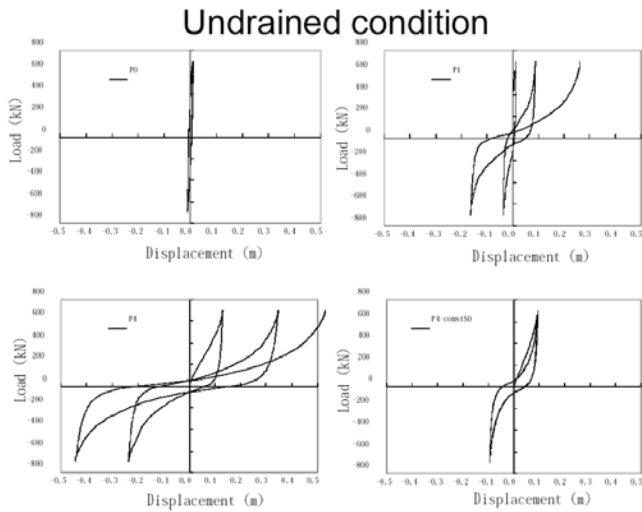

Figure 3: Predicted p-y behavior from FEM analysis of pile

or inverted S-shaped behavior. The cause of the behavior is that sand that is dense of its critical state exhibits a dilatant tendency that is suppressed in undrained loading and manifests as a drop in pore water pressure. This drop in pore pressure causes an increase in effective stress that produces the strain hardening response. The experimental studies in Figs. 1 and 2 contained medium dense sand, and similar behavior has also been documented for loose sand in some studies (e.g., Brandenberg et al. 2005), while other studies have shown that p-y behavior remains soft and weak in loose sand (e.g., Wilson et al. 2000). Loose sand that is initially loose of its critical state may become dense of its critical state when the effective stress decreases during liquefaction, which can help explain the dilatant tendency at large displacements in such material.

Earthquakes can induce strains in the soil due to lateral deflection of the pile and also by free-field ground shaking. Static load tests (e.g., Ashford and Rollins 2002) show that near-field soil strains mobilized by pile movement can induce the dilatancy response. Brandenberg et al. (2005) showed that free-field shaking can also induce the dilatancy response in the sand, which combines with the near-field dilatancy response to alter the p-y behavior.

Concave-up p-y behavior has been widely acknowledged by many researchers, yet p-y materials commonly used in analysis of piles in liquefied ground are typically scaled versions of non-liquefied concave-down p-y relations. For example, Brandenberg (2005) suggested multiplying API (1993) drained p-y relations by a constant p-multiplier that is smaller than 1.0 (e.g., around 0.05 to 0.1 for loose sand) to approxi-

mate the effects of liquefaction on pile foundations. Many other researchers have suggested similar measures, and in some cases researchers have suggested neglecting the liquefied ground altogether (e.g., Dobry et al. 2003). Rollins et al. (2005) suggested a functional form for concave-up p-y behavior based on results of static load tests in blast-induced liquefied ground, and the functional form provided a better fit with measured bending moment distributions than concave-down p-y materials scaled by a p-multiplier. This study clearly shows that concave-up p-y materials can provide more accurate solutions in liquefied ground in the absence of lateral spreading, but it is unclear how such materials affect static analysis results when lateral spreading occurs. In this study, an example analysis is presented in which concave-up p-y materials are used in combination with a static beam on nonlinear Winkler foundation analysis of a single pile in a laterally spreading soil profile. The following analysis was originally presented by Kashighandi (2009).

EXAMPLE ANALYSIS

Consider a profile of 5m of liquefiable loose sand ($\gamma=18\text{kN/m}^3$, $\phi'=32^\circ$, $\eta_h=9,500\text{kN/m}^3$) over dense sand ($\gamma=20\text{kN/m}^3$, $\phi'=38^\circ$, $\eta_h=32,600\text{kN/m}^3$) with a single 10m long 0.61m (24") diameter cast-in-drilled-hole pile ($M_y=400\text{kN}\cdot\text{m}$, $EI=5.8\cdot 10^4\text{kN}\cdot\text{m}^2$) embedded in the profile (Fig. 4). A design-level earthquake is anticipated to cause 0.5m of lateral spreading at the ground surface, and the lateral spreading displacement is assumed to be attributed entirely to uniform strain in the liquefiable sand layer.

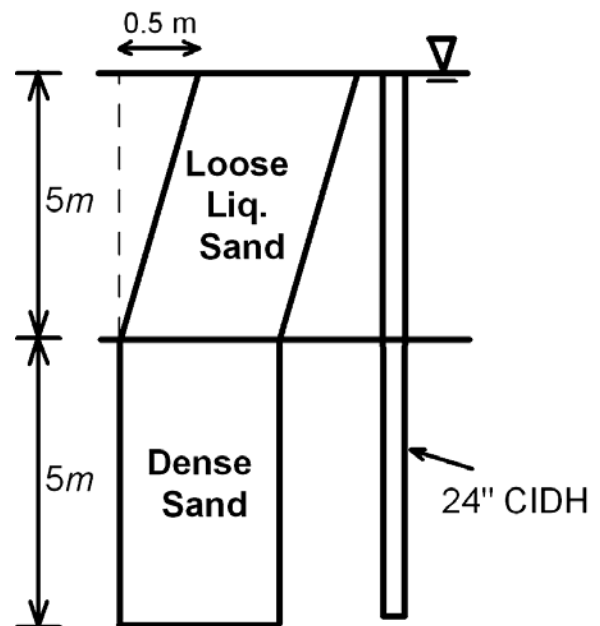

Figure 4: Profile for example analysis.

Drained p-y materials are computed at each depth along the pile, and the p-y material at a depth of 2.5m is shown in Fig. 5. This p-y material is then adjusted to account for the effects of liquefaction in several different ways. First, the p-y material is scaled down by a factor of 0.05 in loose sand using the p-multiplier procedure recommended by Brandenburg (2005). Second, concave-up p-y materials are implemented in which the mobilized value at $y=0.25m$ is adjusted to be 0.5, 1.0, and 2.0 times the capacity of the drained p-y relation. The concave-up p-y materials are reasonably consistent with the shape of the curves that have been measured in model studies and field tests. For comparison, the concave-up form by Rollins et al. (2005) is superposed on Fig. 5, with the maximum value set to 15 kN/m to be consistent with their recommended range of use based on experimental validation. This curve is consistent with the $0.5 \cdot p_{uAPI}$ curve. Similar adjustments to the API drained sand curves were performed at each depth along the pile (i.e. concave up curves were generated with 0.5, 1.0, and 2.0 times the capacity predicted by API equations), and a p-multiplier of 0.05 was used in the loose sand and 0.5 was used in the dense sand layer (to account for some generation of excess pore pressure) for the p-multiplier method.

The pile was analyzed using the finite element platform OpenSees, and the concave-up p-y materials were implemented using a variation of the PyLiq1 material in which the mean effective stress was input directly to the element rather than being read from an adjacent liquefiable continuum mesh. This material is currently under development and is not yet available in the release version of OpenSees. The pile was modeled using 20 nonlinear beam column elements with p-y elements attached at each node. The free-field ground displacement was imposed incrementally. The resulting profiles

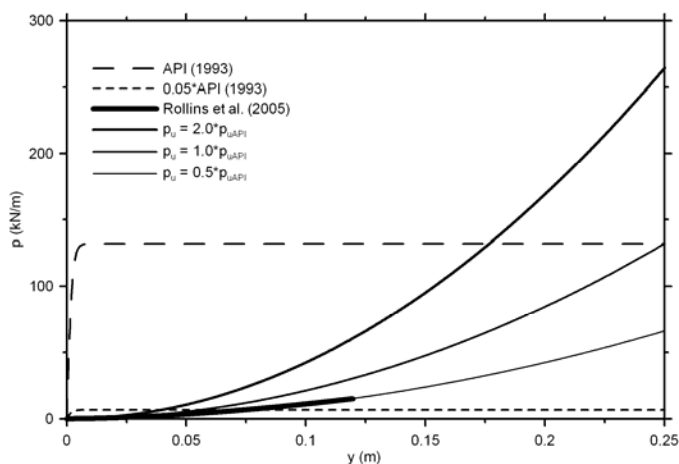

Figure 5: Various p-y materials adopted in static analyses.

of pile displacement, bending moment, and subgrade reaction load are shown in Fig. 6.

The load cases with the concave-up p-y materials (Fig. 6a-c) predict significant displacement at the top of the pile, and predict that the pile would yield at the interface between the loose and dense sand layer. The amount of pile top displacement and the curvature ductility mobilized in the pile are very sensitive to the selection of the ultimate mobilized value of the concave-up p-y material, and in general strong p-y materials place larger demands on the pile. The displacement at the top of the pile was 0.35m, 0.25m, and 0.15m using the concave-up p-y materials with ultimate mobilized values equal to 2.0, 1.0, and 0.5 times the API sand drained capacity. In contrast, the load case that applied a p-multiplier to the concave-down drained API sand relation (Fig. 6d) predicts much smaller demands on the pile. The pile remains in the elastic range, and the displacement at the pile head is only about 0.02m.

Rollins et al. (2005) suggested that the functional form of the concave-up p-y materials should not be extrapolated beyond $p=15$ kN/m or $y=0.15m$ because that was the range of experimental validation. The numerical study in this case drives some of the springs beyond this range of experimental validation, so assumptions would need to be made to utilize their suggested p-y materials. One assumption would be to extend the functional form beyond the range of experimental validation, in which case the curve would be similar to the $p_u=0.5 \cdot p_{uAPI}$ curve in Fig. 5. Another assumption would be that the material becomes perfectly-plastic when it reaches 15 kN/m. In this case, the curve would lie in between the $0.5 \cdot p_{uAPI}$ curve and the $0.05 \cdot API$ curve in Fig. 5. It is unclear how such a relation would affect the analysis result. Wilson et al. (2000) showed that mobilized values could exceed drained API capacity, which lends some credence to extending the Rollins et al. (2005) concave-up functional form beyond the range of experimental validation.

This is a purely numerical study that cannot be compared with test data for validation, but nevertheless the general trend is clearly illustrated that static analyses that utilize concave-up p-y materials that are capable of mobilizing significant loads are more demanding on piles in laterally spreading ground compared with concave-down p-y materials adjusted by a p-multiplier. The concave-down p-y materials provided reasonable predictions of the measured bending moments from the centrifuge test study presented by Brandenburg et al.

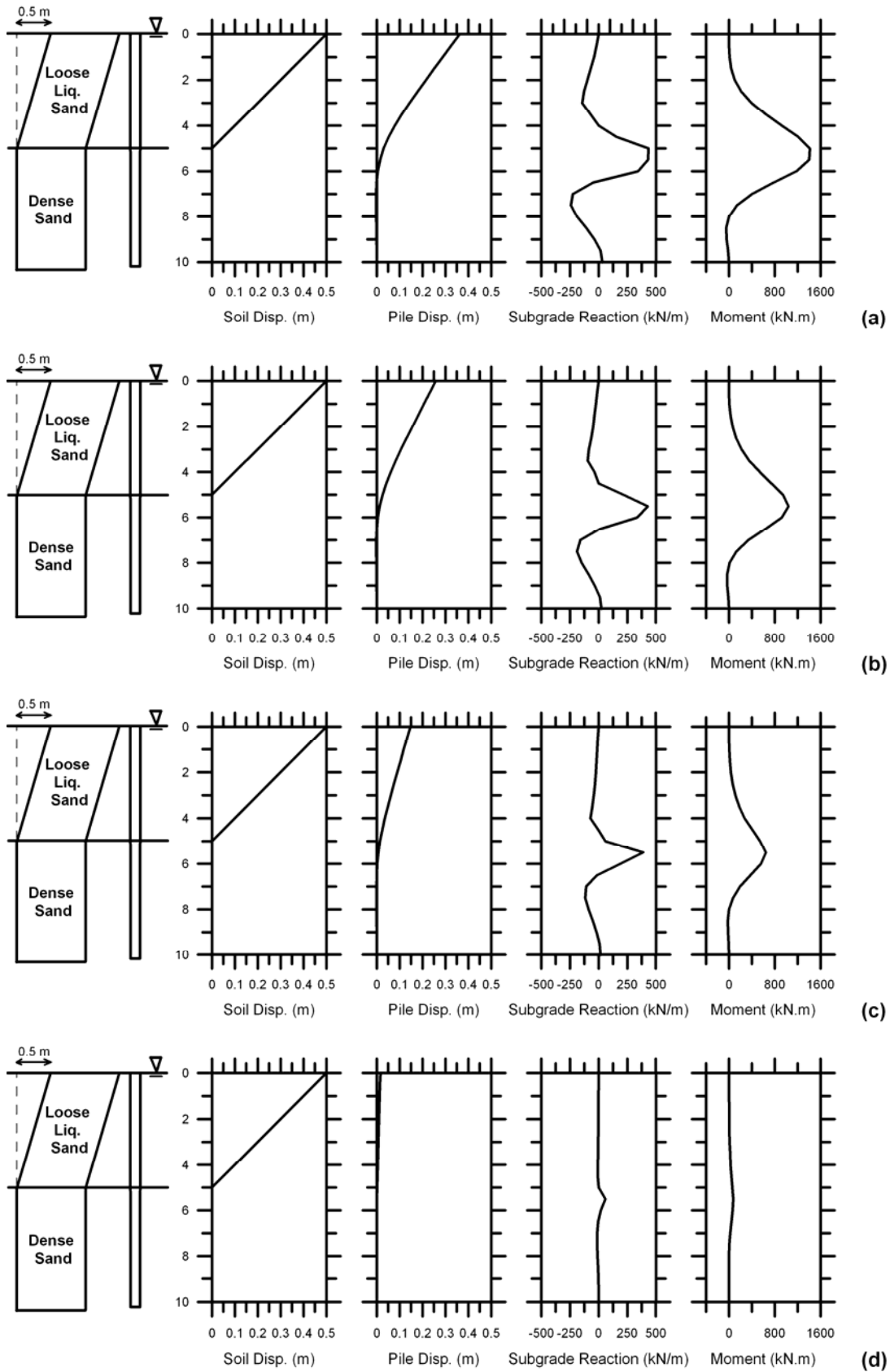

Figure 6: Results of finite element simulations using concave up p - y materials with ultimate capacity of (a) 2.0x API drained relation (b) 1.0x API drained relation, (c) 0.5x API drained relation, and concave down p - y material obtained by applying a p -multiplier of 0.05 to the drained API relation..

(2007), despite the fact that dilatant behavior was observed in the liquefied layer in that study. An inconsistency between the large shear strains assumed in the lateral spreading profile and the strain-hardening p-y capacity renders the concave-up p-y materials inappropriate for static analysis of lateral spreads, as discussed in the next section.

DISCUSSION

Lateral spreads can be caused by two distinct mechanisms. Either shear strains accumulate in liquefied layers, or a distinct slip develops at an interface where a low-permeability layer overlies a higher permeability layer. This discussion is concerned with the former mechanism, which is consistent with the free-field displacement pattern imposed on the pile in Fig. 6. Accumulation of shear strain in a liquefied layer during cyclic loading (i.e. cyclic mobility) is characterized by a low-stiffness, low-strength region where shear strains and shear stresses are small, and excess pore pressures are high, followed by a higher stiffness region where strains become large enough to mobilize the dilatancy response in the sand. The strain required to mobilize the dilatancy response increases with each cycle as the fabric of the sand becomes remolded, which results in accumulation of permanent displacement in the direction of static driving shear stress.

In the context of this paper, the important distinction is that permanent ground displacements accumulate primarily during times of high excess pore water pressure, and not during times of dilatancy. Rather, shear strain increments during dilatancy cycles are small due to the temporarily increased stiffness of the liquefiable sand. The free-field displacement profile imposed on the pile in Fig. 6 does not capture this important feature of site response. Rather, the free-field displacement profile is simply increased incrementally, and strain increments are constant and are not decreased as the dilatancy response in the p-y material is mobilized. The strain hardening p-y material implies that the sand is becoming stiffer and stronger as loading progresses, but the free-field displacement pattern does not reflect this stiffening. Hence, the a displacement pattern that is consistent with a soft, weak liquefiable layer is being imposed on a p-y material that is consistent with a stiffening, strengthening liquefiable layer. As a result, the soil grabs hold of the pile and displaces it downslope, whereas soft, weak lateral spreading soil would be anticipated to flow around a strong, stiff pile.

The large strains in the free-field displacement pattern are inconsistent with a dilatancy response in the free field. How-

ever, a more complicated case could arise wherein the strain increment in the free-field is large while the sand is in the soft and weak portion of the cyclic mobility behavior, but large shear strains imposed on the soil by the pile generate the dilatant response in the near field. This mechanism was clearly demonstrated by Gonzalez (2005), where an inverted cone of dilatant soil formed, thereby increasing the effective diameter of the pile. Clarifying this mechanism is beyond the scope of this paper.

The studies in which concave-up p-y behavior has been observed for piles with reasonable flexural stiffness all involved cases where the pile was loading the soil at the time that large subgrade reaction loads were recorded, and none have involved cases where the soil was loading the pile. The large subgrade reaction loads are reactions against other external loads imposed above the ground surface by an actuator (static load test), inertia loading (dynamic model test), or kinematic demands from a laterally spreading crust. For example, Brandenberg et al. (2005) recorded large upslope subgrade reaction loads in liquefied sand that reacted against downslope kinematic demands from the laterally spreading clay crust. In that case, the crust slipped on top of the liquefied sand due to void redistribution and the liquefiable layer exhibited very little shear strain. The literature is void of a case wherein a large downslope subgrade reaction force was mobilized against a pile with reasonable flexural stiffness by laterally spreading soil. However, large downslope loads have been measured against very stiff, essentially rigid piles (Haigh and Madabhushi 2006), which could have implications for caisson foundations or buried bulkheads.

Concave up p-y materials have been successfully implemented in dynamic analyses that couple the p-y behavior to the response of a liquefying free-field soil mesh (e.g., Chang 2007). The site response analysis inherently accounts for the strain increments that occur during dilatancy cycles, and impose correspondingly small displacement increments on the pile during these cycles. Hence, the mismatch between p-y strength/stiffness and the imposed displacement profile does not exist in dynamic analyses that appropriately model the dilatancy response of liquefied sand. However, these models do not capture the near-field dilation response due to strains induced on the soil by the pile.

Concave-up p-y materials may be appropriate for static analyses without lateral spreading, where inertia demands are imposed on the foundation and zero or very little free-field shear

strain is assumed in the liquefied layer. For example, Rollins et al. (2005) showed better agreement between predicted and measured bending moment distributions when concave-up p-y materials were used than when the p-multiplier approach was used.

Concave-up p-y materials with a relatively low ultimate value that is proportional to the strain in the liquefied soil layer may be appropriate. For example, the ultimate value of a concave-up p-y material could be capped at 15kN/m [the range of experimental validation specified by Rollins et al. (2005)], or at some specified small p-multiplier value. Limiting the capacity of the concave-up material would be consistent with the soft, weak behavior implied by the large shear strains imposed in the layer. Exploring this approach is beyond the scope of this paper.

CONCLUSIONS

Concave up p-y behavior has been observed in a many recent physical and numerical studies of pile foundations in liquefied ground, with measured subgrade reaction loads sometimes exceeding the drained capacity predicted by equations for p-y material behavior in nonliquefied ground. However p-y materials for analysis of lateral spreads are typically scaled-down versions of concave-down drained p-y relations. A mismatch between the large free-field ground displacement and the high strength and stiffness implied by a strong, dilatant p-y material can render unrealistically large predictions of pile displacement and flexural demand, at least for cases where the mobilized value of the p-y material is a significant fraction of the drained resistance. Limiting the capacity of a concave-up p-y material to a small value in layers with significant imposed soil shear strains would be consistent with the assumption that the soil is soft and weak. Concave-up p-y materials may be appropriate for dynamic analysis of liquefied laterally spreading ground, or for static analysis in the absence of lateral spreading.

ACKNOWLEDGEMENTS

This work was part of a research program to develop fragility functions for bridges in liquefied and laterally spreading ground, which was funded by the California Department of Transportation and the National Science Foundation through the Pacific Earthquake Engineering Research Center under project no. SA5407:1 (Caltrans) and SA5258 (NSF). Tom

Shantz was the contract coordinator. The contents of this paper do not necessarily represent a policy of either agency or endorsement by the state or federal government.

REFERENCES

American Petroleum Institute (API). (1993). *Recommended Practice for Planning, Design, and Constructing Fixed Offshore Platforms*. API RP 2A - WSD, 20th ed., American Petroleum Institute.

Ashford, S. A., and Rollins, K. M. (2002). *TILT: The Treasure Island Liquefaction Test: Final Report*, Report SSRP-2001/17, Department of Structural Engineering, University of California, San Diego.

Brandenberg, S.J., Boulanger, R.W., Kutter, B.L., and Chang, D. (2005). "Behavior of pile foundations in laterally spreading ground during centrifuge tests." *J. Geotech. Geoenviron. Eng.*, ASCE., 131(11), 1378-1391.

Brandenberg, S.J. (2005). "Behavior of piles in liquefied and laterally spreading ground." Ph.D. Dissertation. University of California, Davis, CA, 344 pp.

Brandenberg, S.J., Boulanger, R.W., Kutter, B.L., and Chang, D. (2007). "Static pushover analyses of pile groups in liquefied and laterally spreading ground in centrifuge tests." *J. Geotech. Geoenviron. Eng.*, ASCE, 133(9), 1055-1066.

Chang, D. (2007). "Inertial and lateral spreading demands on soil-pile-structure systems in liquefied and laterally spreading ground during earthquakes." Ph.D. Dissertation. University of California, Davis, CA, 253 pp.

Dobry, R., Abdoun, T., O'Rourke, T. D., and Goh, S. H. (2003). "Single Piles in Lateral Spreads: Field Bending Moment Evaluation." *J. Geotech. Geoenviron. Eng.*, ASCE, Vol. 129(10), 879-889.

Gonzalez, L. (2005). "Centrifuge modeling of permeability and pinning reinforcement effects on pile response to lateral spreading." Ph.D. dissertation. Rensselaer Polytechnic Institute, Troy, NY, 464 pp.

Haigh, S.K. & Madabhushi, S.P.G. (2005) The effects of Pile Flexibility on Pile-Loading in Laterally Spreading Slopes. In *Seismic Performance of Pile Foundations in Liquefied and Laterally Spreading Ground*, ASCE Special Publication 145, 24-37

Iai, S. (2002). "Analysis of soil deformation around a cylindrical rigid body." Proc. U.S.-Japan Seminar on Seismic Disaster Mitigation in Urban Area by Geotechnical Engineering, I. Towhata and R. W. Boulanger, eds., Anchorage, Alaska, June.

Kashighandi, P. (2009). "Demand fragility surfaces for bridges in liquefied and laterally spreading ground." Ph.D. Dissertation. University of California, Los Angeles, CA, 260 pp.

Rollins, K., Gerber, T.M., Lane, J.D., and Ashford, S.A. (2005). "Lateral resistance of a full-scale pile group in liquefied sand." *J. Geotech. Geoenviron. Eng.*, ASCE, 131(1), 115-125.

Wilson, D. W., Boulanger, R. W., and Kutter, B. L. (2000). "Seismic lateral resistance of liquefying sand." *J. Geotech. Geoenviron. Eng.*, ASCE, 126(10), 898-906.