

Lawrence Berkeley National Laboratory

Recent Work

Title

CRYOSTAT AND ELECTRONIC DEVELOPMENT ASSOCIATED WITH MULTI-DETECTOR SPECTROMETER SYSTEMS

Permalink

<https://escholarship.org/uc/item/34d41977>

Author

Pehl, R.H.

Publication Date

1984-10-01

c.2



Lawrence Berkeley Laboratory

UNIVERSITY OF CALIFORNIA

RECEIVED
LAWRENCE
BERKELEY LABORATORY

MAR 15 1985

LIBRARY AND
DOCUMENTS SECTION

Engineering & Technical Services Division

Presented at the IEEE Nuclear Science Symposium,
Orlando, FL, October 31-November 2, 1984; and to
be published in IEEE Transactions on Nuclear
Science

CRYOSTAT AND ELECTRONIC DEVELOPMENT ASSOCIATED
WITH MULTI-DETECTOR SPECTROMETER SYSTEMS

R.H. Pehl, N.W. Madden, D.A. Landis,
D.F. Malone, and C.P. Cork

October 1984

TWO-WEEK LOAN COPY

*This is a Library Circulating Copy
which may be borrowed for two weeks.
For a personal retention copy, call
Tech. Info. Division, Ext. 6782.*

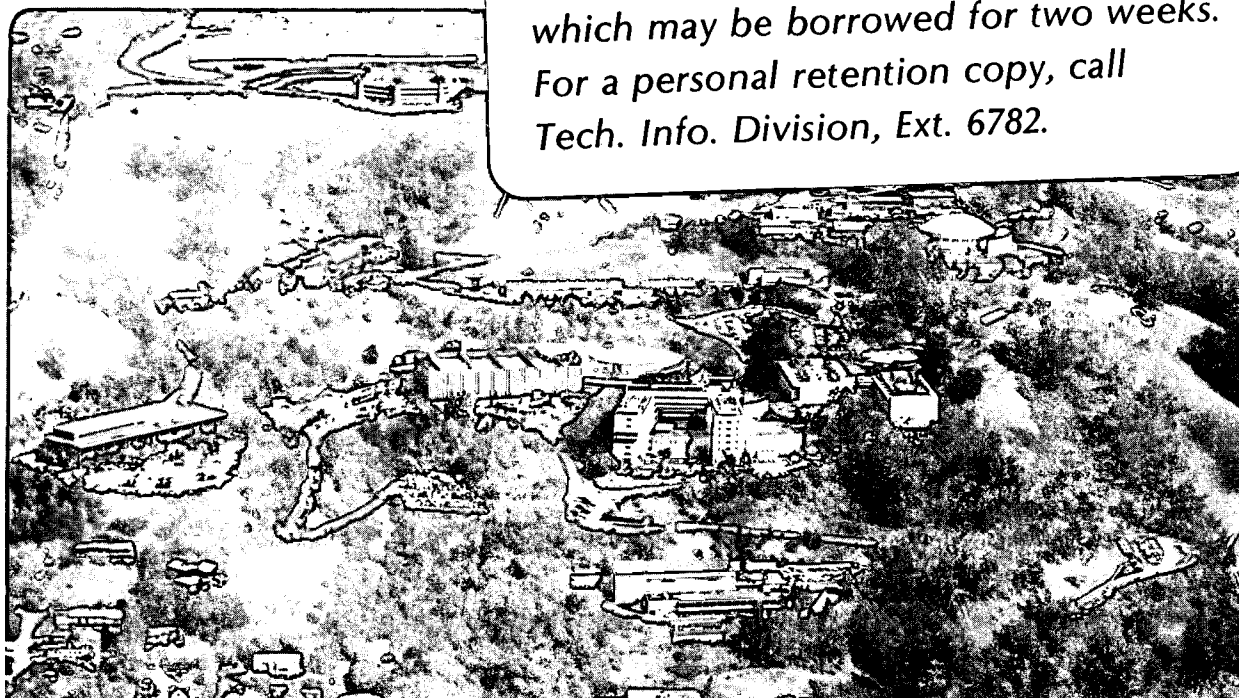

LBL-17872
c.2

DISCLAIMER

This document was prepared as an account of work sponsored by the United States Government. While this document is believed to contain correct information, neither the United States Government nor any agency thereof, nor the Regents of the University of California, nor any of their employees, makes any warranty, express or implied, or assumes any legal responsibility for the accuracy, completeness, or usefulness of any information, apparatus, product, or process disclosed, or represents that its use would not infringe privately owned rights. Reference herein to any specific commercial product, process, or service by its trade name, trademark, manufacturer, or otherwise, does not necessarily constitute or imply its endorsement, recommendation, or favoring by the United States Government or any agency thereof, or the Regents of the University of California. The views and opinions of authors expressed herein do not necessarily state or reflect those of the United States Government or any agency thereof or the Regents of the University of California.

R.H. Pehl, N.W. Madden, D.A. Landis,
D.F. Malone and C.P. Cork

Lawrence Berkeley Laboratory
University of California
Berkeley, California 94720 U.S.A.

Abstract

To overcome the problems of fabricating a practical cryostat that contains a large number of semiconductor detectors and the electronics associated with a high resolution spectrometer system has required a number of significant technological developments. These problems and our corresponding solutions are presented.

Introduction

The problems and solutions discussed below arose during the design and building of a spectrometer containing a 4 x 4 array of high-purity germanium detector elements¹ that will be used in conjunction with a conventional NaI scintillation camera. This spectrometer, shown in Fig. 1, is a forerunner of a proposed system that will contain upwards of 1000 high-purity Ge detector elements. Details of this application have been discussed^{2,3}. For our present purpose a requirement is for excellent resolution and the potential for high rate operation. These factors largely eliminate the use of matrix readout schemes and necessitate the use of one preamplifier per detector element. Since the technology developed should be applicable to a wide range of both cooled and uncooled multi-detector systems, this paper will treat these developments in general terms, although reference will continually be made to the 4 x 4 array. Since the technology involves solving a number of largely unrelated problems the paper is organized into sections dealing with each problem and its solution.

Problems and Solutions

PROBLEM: The total heat load generated within a cryostat by a very large number of FETs operating under typical conditions is greater than the heat load most cryostats can handle without severely compromising other cryostat parameters. For example, even at 20 mW/FET (already on the low power side for optimum operation of most low noise FETs), 1000 FETs would generate 20 W, a huge burden compared to the heat load of typical spectrometers.

SOLUTION: Recognizing that the usefulness of many spectrometers is not significantly degraded by a slight increase in the electronic noise (because other experimental parameters often limit the ultimate resolution), we decided to evaluate the noise performance of cooled FETs under low power conditions. Conventionally packaged (TO-72) Motorola 2N4416 and Interfet 2N6451 FETs were evaluated for noise as a function of temperature and power. Figures 2a and 2b show typical results. With power levels in the 6 to 9 mW range, noise levels as low as 350 eV were obtained with 2N4416 FETs at a peaking time of 2 μ s in the shaping amplifier. These measurements clearly demonstrate that FETs can be operated at far lower than optimum power without causing a significant noise

increase. This conclusion has far reaching implications in the design of many spectrometers. Since TO-72 packages were too large for our desired configuration for the 4 x 4 array, Motorola 2N4416 FETs in SOT-23 packages were used. On these FETs a simple room temperature preselection, based on a noise measurement at 100 KHz with an operating point of 2 V on the drain and 3 mA of drain current, was done. The noise on the individual elements in the 4 x 4 array (peaking time of 2 μ s, detector element capacity of 0.6 pF) range from 680 to 900 eV.

PROBLEM: If typical-sized feedback components are used, the number of front ends that will fit inside the cryostat may well be limited to a number far less than desired. (Front end is defined here as the input FET and associated feedback resistor and capacitor.) A low loss mounting substrate for these components is also required.

SOLUTION: The availability of miniature feedback components as well as the SOT-23 packaged FETs allowed the design and fabrication of a very small modular front end. We used very small, high-value resistors (10^8 - 10^9) made by Mini-Systems, Inc. Fortunately, these resistors have excellent frequency response, permitting excellent pole-zero cancellation in the shaping amplifier. Low-loss, thermally-stable fractional picofarad capacitors are available from a number of manufacturers. We chose 0.5 pF capacitors from American Technical Ceramics. Figure 3 is a photograph of a 16-channel front end; both typical-sized and miniature front-end components are also shown separately for comparison.

Since the optimum operating temperature of JFETs is well above 77°K (refer to Figs. 2a and 2b), controlled heat leaks were used to achieve an operating temperature of 120°K for the entire 16 channel front-end module. In this configuration the operating temperature of the Ge detectors was 92°K.

Two types of printed circuit board material were evaluated for use as the front-end substrate. FR4 is the material most commonly used today for printed circuit boards. While FR4 has the important attribute of being very stable dimensionally as a function of temperature (i.e., the difference in the size and shape of FR4 at room temperature and 120°K is negligible), it contributes substantial 1/f noise at room temperature. Fortunately, this 1/f noise is significantly reduced when FR4 is cooled to 120°K. A glass-fiber loaded teflon printed circuit board material, RT/Duroid, made by Rogers Corporation, was found to contribute substantially less 1/f noise at room temperature. A tabulation of these measurements is presented in Table 1. Since the substrate temperature for the 4 x 4 array of Ge detectors was 120°K we chose FR4 because the noise levels at this temperature were acceptable and its dimensional stability was desirable.

Comparison of Noise Contributions When Different Substrate Materials are used at Room Temperature

Amplifier Peaking Time (μ s)	Noise (keV)	
	FR4	RT/Duroid
0.5	1.17	.79
1	1.13	.76
2	1.17	.86
4	1.4	1.05

All noise values expressed in FWHM where $Ge \epsilon = 2.96 \text{ eV/h-e pair}$.

PROBLEM: The cryostat must have a very large number of vacuum tight feed-throughs. Since tight spatial restrictions are often placed on the flange that contains these feed-throughs, conventional technology may well limit the possible feed-throughs to a number far less than desired.

SOLUTION: For the 4 x 4 array of Ge detectors, a very low profile forty-nine wire vacuum feed-through was constructed of two copper clad FR4 printed circuit boards epoxied to each other and captured between two O-ring vacuum seals. Figure 4 shows these two printed circuit boards bonded together with Lusol CK-A-12 epoxy. This vacuum seal is illustrated as part of the cross-sectional view of the cryostat shown in Figure 5. One of these circuit boards also serves as the "mother board" into which are plugged the 16 preamplifiers just external to the vacuum chamber. Voltage rails, signal grounds and output signals for these preamplifiers are provided by two ten-coaxial ribbon cables which are mechanically and electrically terminated on this same "mother board".

If more feed-throughs are required than can be accumulated on the present two-board composite, additional layers can be added.

PROBLEM AND SOLUTION: To satisfy the need for miniaturized preamplifiers that are geometrically compatible with large detector arrays a small, 4.3 cm x 3.3 cm x 1 cm low-noise preamplifier was developed. Figure 6 is a photograph of this preamplifier. All the transistors, both field-effect and bipolar, are in SOT-23 packages. Resistors are 1/8 W. Conventional capacitors are used throughout. Two simple feedback loops are used in the preamplifier. The first is charge-sensitive and utilizes a resistive charge restoration. For simplicity the second loop is an inverting stage with a gain of five, capable of driving coaxial cable. The two loops are dc coupled.

The noise performance of these miniaturized preamplifiers was found to be identical to that of conventional, high-quality preamplifiers when the input FET was operated under low power conditions. These miniaturized preamplifiers have already found use in a wide variety of applications.

PROBLEM AND SOLUTION: To satisfy the need for high-quality linear pulse shaping amplifiers at a cost compatible with large detector arrays, a NIM module containing 8 shaping amplifiers was developed. The block diagram of the amplifier is shown in Fig. 7. The amplifier produces a 4-pole pseudo Gaussian pulse shape with 2 μ s peaking time and a total width of approximately 6.5 μ s. The amplifier stages use inexpensive operational amplifiers throughout. The

first two stages are dc coupled, provide most of the gain, and behave as four active integrators. The third stage has an active bipolar wraparound baseline restorer and also contains the fine gain control and output coaxial cable driver. The amplifier performance was verified with both resistor feedback and pulsed reset feedback preamplifier; no degradation in resolution was observed up to 40 KHz input rates. Flat ten-coaxial mass terminated cables are used at the input and output of each 8-channel amplifier module. The input coaxial cable also supplies two dc rails ($\pm 24 \text{ V}$) to the preamplifiers. While these amplifiers were developed specifically for the 4 x 4 array they can also be used when the much larger array is built. Additional features of these amplifiers include adjustable gain from x18 to x400, adjustable pole-zero compensation and output dc zero control.

Logic Unit for the 4 x 4 Array

Although this unit was developed to satisfy the particular logic requirements of the signals from the 4 x 4 array and does not fall in the class of general developments discussed previously, it is mentioned here for completeness. The use of this logic unit is also discussed in another paper in this volume⁴.

A block diagram of the logic unit is shown in Fig. 8. The signals from the amplifiers are sent to the pre-processing logic unit and then the corresponding digital signals are sent on to a computer for final analysis. The logic unit contains 16 channels of zero crossing discriminators, upper and lower level discriminators, adjustable delay and 6 bit, 100 ns flash ADCs. The zero crossing signals provide timing information from the Ge detectors which are used to strobe the energy signals into the flash ADCs. Timing walk of the zero crossing discriminator over the energy range of 2 to 50 keV was only a few ns. The timing signals are combined in a 16 input to 4 bit output encoder that provides the address of the detector element. A greater than one circuit rejects events when more than one detector element receives simultaneous signals. The ORed output from the encoder is used in coincidence with a timing signal from the NaI scintillator. Energy signals from the Ge and NaI detectors in coincidence are digitally added and a logic signal is produced when the sum signal falls within a preset energy window. The logic signal, the energy signal from the Ge detector element, and detector element number are sent to a computer for further processing.

Disclaimer

Reference to a company or product name does not imply approval or recommendation of the product by the University of California or the U. S. Department of Energy to the exclusion of others that may be suitable.

Acknowledgments

Fred Goulding, Paul Luke, John Anderson, Andrew Jue and Enola Converse have made important contributions during the course of reaching the solutions presented in this paper. Manbir Singh at USC stimulated some of our thoughts concerning the problems.

This work was supported by a grant No R01-CA28105-04 awarded by the National Cancer Institute through the University of Southern California and by the Director's Office of Energy Research, Nuclear Sciences of the Basic Energy Sciences Program, U. S. Department of Energy under Contract No. DE-AC03-76SF00098.

References

- [1] P.N. Luke, IEEE Trans. Nucl. Sci., NS-31, 312 (1984).
- [2] M. Singh, Med. Phys. 10 (4), 421 (1983).
- [3] M. Singh and D. Doria, Med. Phys. 10 (4), 428 (1983).
- [4] M. Singh and D. Doria, IEEE Trans. Nucl. Sci., NS-32, No. 1, (1985).

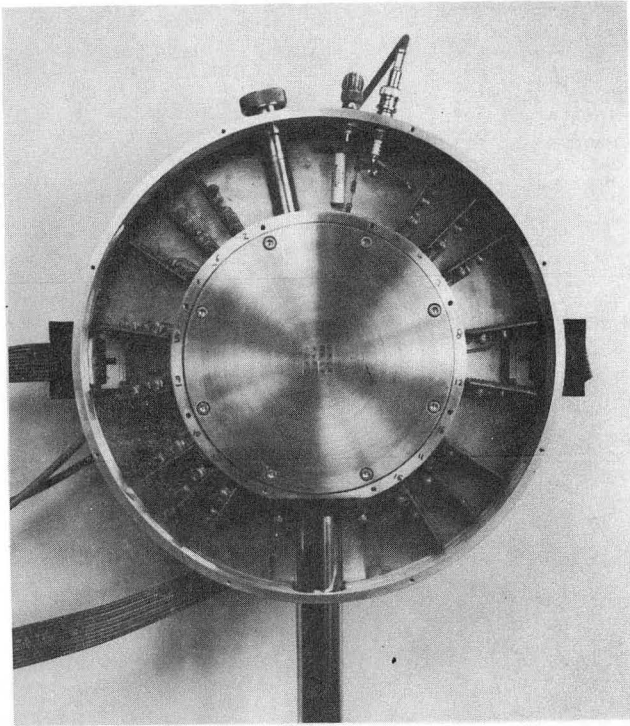
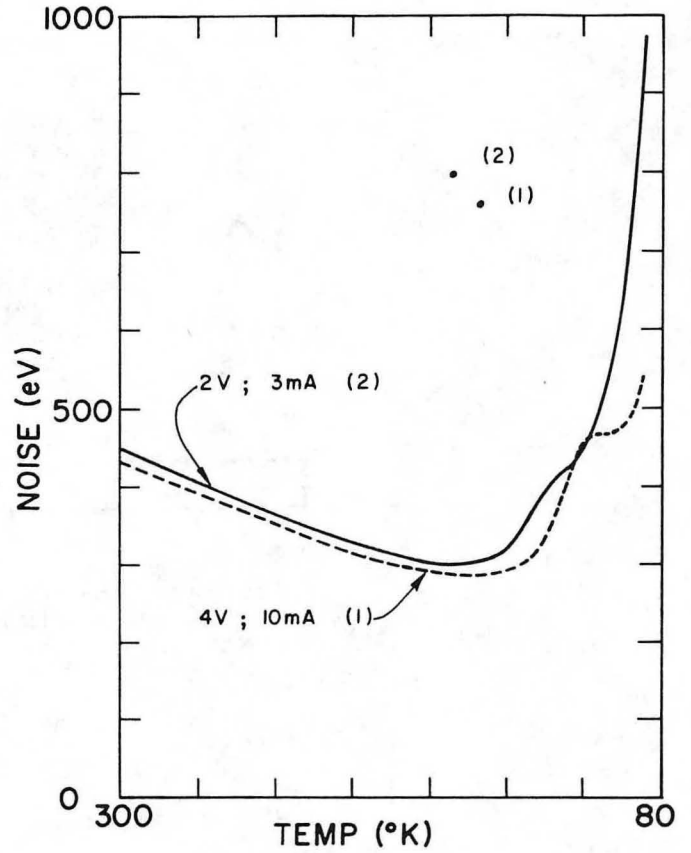
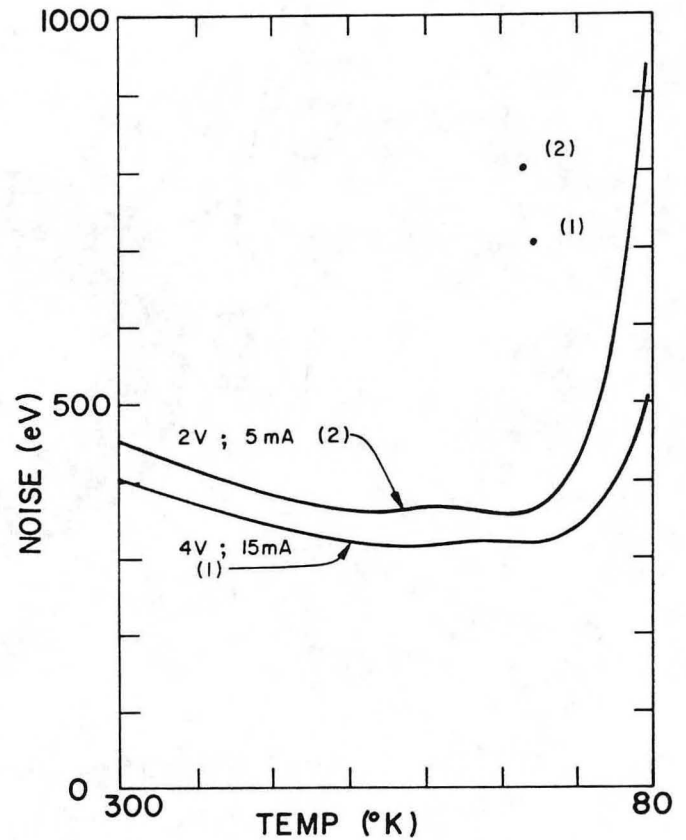

Fig. 1 Photograph of the spectrometer that contains a 4 x 4 array of high-purity germanium detector elements as viewed from the pre-amplifier side. The peripheral electrostatic shield has been removed for clarity.



2a)

XBL 8410-4165



2b)

XBL 8410-4164

Fig. 2a This set of curves is representative of the performance of a small geometry JFET. Points 1 and 2 correspond to an input capacity increase of 12 pF compared to curves 1 and 2, respectively.

Fig. 2b This set of curves is representative of the performance of a large geometry JFET. Points 1 and 2 correspond to an input capacity increase of 12 pF compared to curves 1 and 2, respectively.

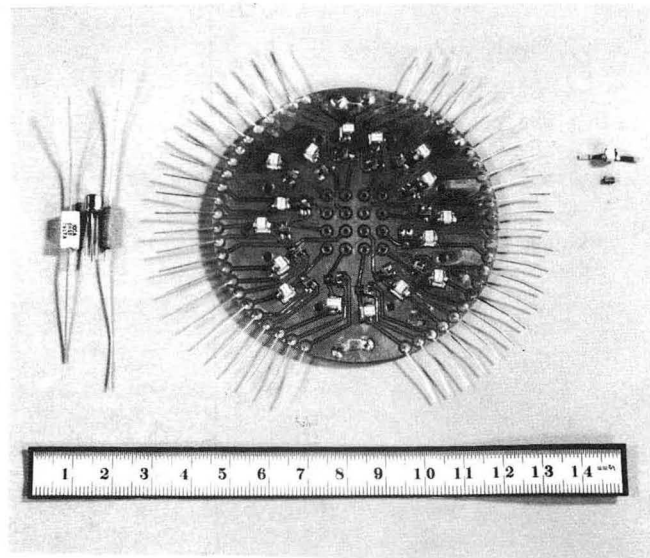
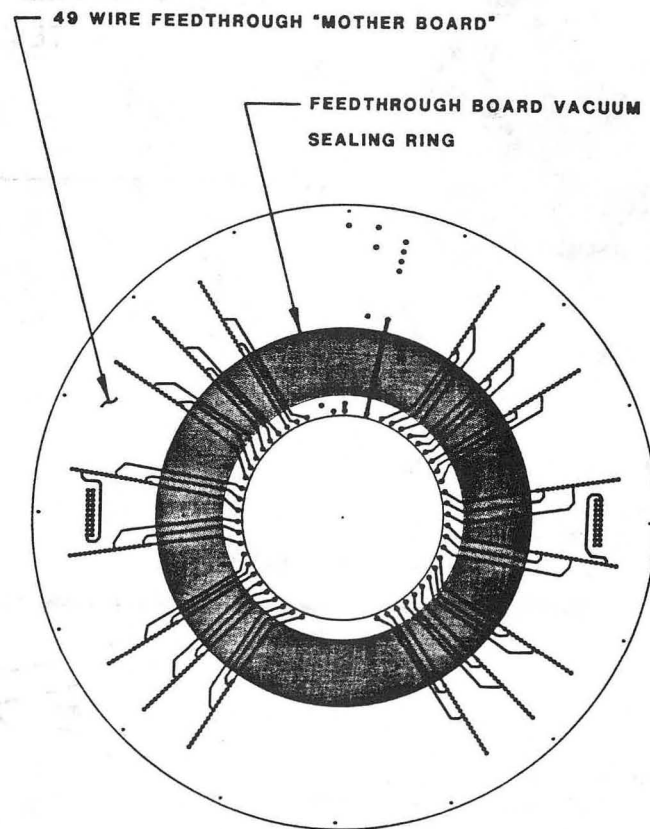
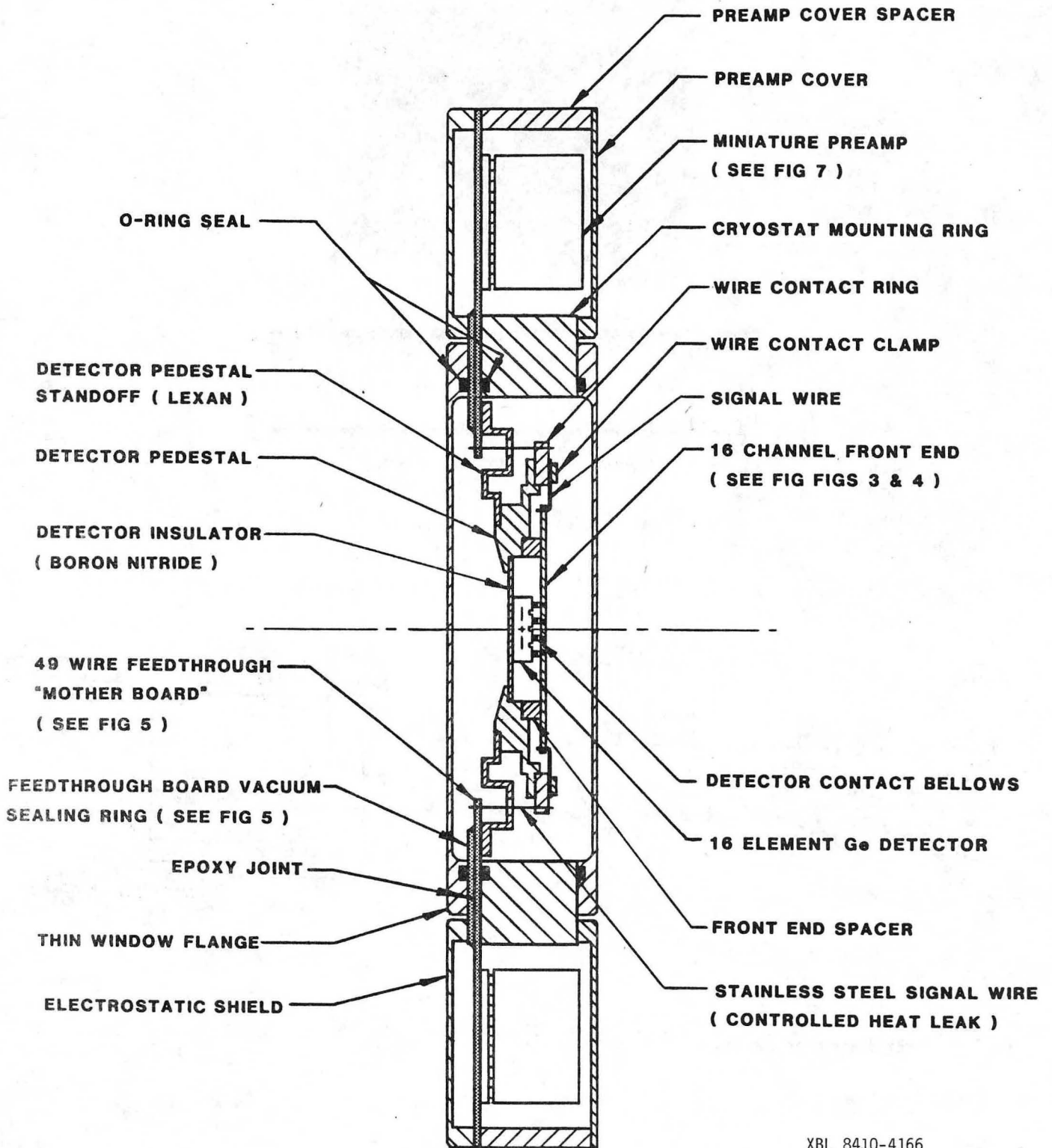

Fig. 3 Photograph of the 16-channel front end. Both standard-sized and miniature front-end components are also shown separately for comparison.



XBL 8410-4163

Fig. 4 Drawing of two printed circuit boards as banded together to form a very low profile forty-nine vacuum feed-through.



XBL 8410-4166

Fig. 5 Cross-sectional view of the cryostat. Note the relatively simple construction that nevertheless provides a very large number of vacuum feed-throughs.

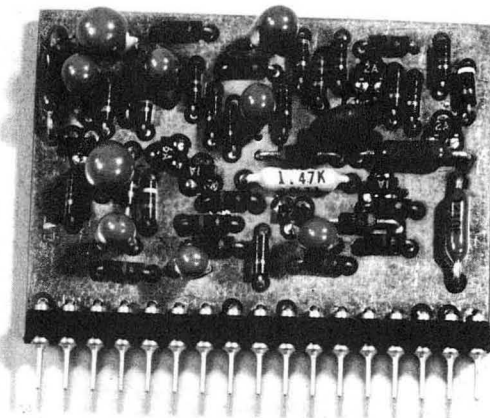
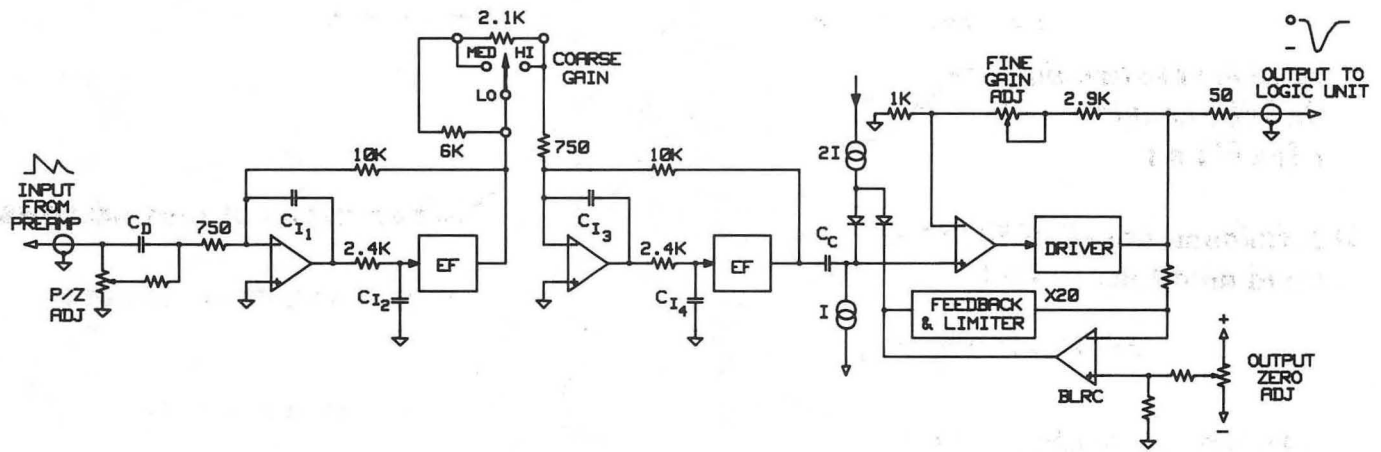
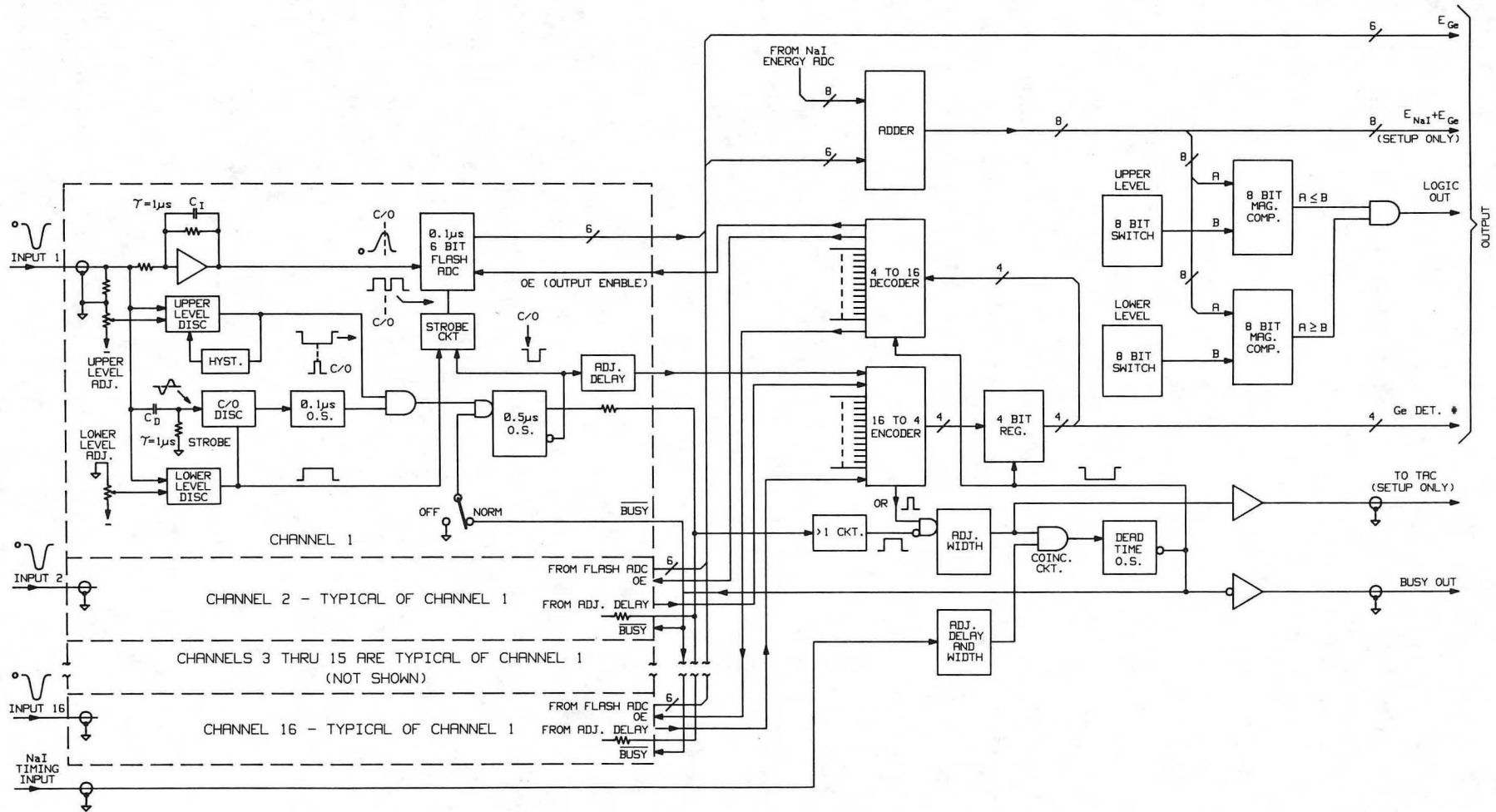

Fig. 6 Photograph of the miniature preamplifier.



XBL 8410-4342

Fig. 7 Block diagram of the linear pulse shaping amplifier.



XBL 8410-4341

Fig. 8 Block diagram of the logic unit for the 4 x 4 array.

This report was done with support from the Department of Energy. Any conclusions or opinions expressed in this report represent solely those of the author(s) and not necessarily those of The Regents of the University of California, the Lawrence Berkeley Laboratory or the Department of Energy.

Reference to a company or product name does not imply approval or recommendation of the product by the University of California or the U.S. Department of Energy to the exclusion of others that may be suitable.

TECHNICAL INFORMATION DEPARTMENT
LAWRENCE BERKELEY LABORATORY
UNIVERSITY OF CALIFORNIA
BERKELEY, CALIFORNIA 94720