

UCSF

UC San Francisco Previously Published Works

Title

Toward Continuous, Noninvasive Assessment of Ventricular Function and Hemodynamics:  
Wearable Ballistocardiography

Permalink

<https://escholarship.org/uc/item/2xz1625s>

Journal

IEEE Journal of Biomedical and Health Informatics, 19(4)

ISSN

2168-2194

Authors

Wiens, Andrew D  
Etemadi, Mozziyar  
Roy, Shuvo  
et al.

Publication Date

2015-07-01

DOI

10.1109/jbhi.2014.2359937

Peer reviewed

# Toward Continuous, Noninvasive Assessment of Ventricular Function and Hemodynamics: Wearable Ballistocardiography

Andrew D. Wiens, *Student Member, IEEE*, Mozziyar Etemadi, *Student Member, IEEE*, Shuvo Roy, *Member, IEEE*, Liviu Klein, and Omer T. Inan, *Member, IEEE*

**Abstract**—Ballistocardiography, the measurement of the reaction forces of the body to cardiac ejection of blood, is one of the few techniques available for unobtrusively assessing the mechanical aspects of cardiovascular health outside clinical settings. Recently, multiple experimental studies involving healthy subjects and subjects with various cardiovascular diseases have demonstrated that the ballistocardiogram (BCG) signal can be used to trend cardiac output, contractility, and beat-by-beat ventricular function for arrhythmias. The majority of these studies has been performed with “fixed” BCG instrumentation—such as weighing scales or chairs—rather than wearable measurements. Enabling wearable, and thus continuous, recording of BCG signals would greatly expand the capabilities of the technique; however, BCG signals measured using wearable devices are morphologically dissimilar to measurements from “fixed” instruments, precluding the analysis and interpretation techniques from one domain to be applied to the other. In particular, the time intervals between the electrocardiogram (ECG) and BCG—namely, the R–J interval, a surrogate for measuring contractility changes—are significantly different for the accelerometer compared to a “fixed” BCG measurement. This paper addresses this need for quantitatively normalizing wearable BCG measurement to “fixed” measurements with a systematic experimental approach. With these methods, the same analysis and interpretation techniques developed over the past decade for “fixed” BCG measurement can be successfully translated to wearable measurements.

**Index Terms**—Accelerometer, ballistocardiogram, home health monitoring, wearable health technology.

## I. INTRODUCTION

**C**ARDIOVASCULAR disease (CVD) represents one of the biggest challenges facing our society today, and in the

Manuscript received May 12, 2014; revised July 19, 2014 and September 2, 2014; accepted September 12, 2014. Date of publication September 23, 2014; date of current version July 23, 2015. This work was supported in part by the National Center for Advancing Translational Sciences, National Institutes of Health, under UCSF-CTSI Grant UL1 TR000004, and the CIMIT Prize for Primary Care Innovation.

A. D. Wiens and O. T. Inan are with the School of Electrical and Computer Engineering, Georgia Institute of Technology, Atlanta, GA 30308 USA (e-mail: andrew.wiens@gatech.edu; inan@gatech.edu).

M. Etemadi is with the Department of Electrical Engineering and Computer Science, University of California Berkeley, Berkeley, CA 94720 USA and also with the Department of Bioengineering and Therapeutic Sciences, University of California, San Francisco, San Francisco, CA 94158 USA (e-mail: mozziyar.etemadi@ucsf.edu).

S. Roy is with the Department of Bioengineering and Therapeutic Sciences, University of California, San Francisco, San Francisco, CA 94158 USA (e-mail: shuvo.roy@ucsf.edu).

L. Klein is with the School of Medicine, University of California, San Francisco, San Francisco, CA 94143 USA (e-mail: lklein@medicine.ucsf.edu).

Color versions of one or more of the figures in this paper are available online at <http://ieeexplore.ieee.org>.

Digital Object Identifier 10.1109/JBHI.2014.2359937

coming decades. In 2013, CVD accounted for one in four deaths in the U.S., and afflicted more than 1 in 3 people [1]; by 2030, the American Heart Association (AHA) projects that 40.5% of Americans will suffer with CVD and the projected medical costs will exceed \$800 billion [2]. At the same time, in the coming years, there is a projected shortage in the number of healthcare providers both in the U.S. and worldwide [3]–[5]. The combination of increasing numbers of patients with CVD, increasing medical costs related to CVD, and decreasing number of providers can only be addressed by dramatic changes in the way that care is delivered [6].

Home monitoring of cardiovascular health represents a viable alternative to the current model of reactive CVD management [6]–[9]. Actionable solutions for physiological monitoring at home that capture the complexity required for titrating care could greatly reduce healthcare costs, improve the effectiveness of the therapy by better addressing the changing needs of the patients, and empower the patients against their diseases by enabling them with information regarding their physiological state. These home monitoring technologies must be unobtrusive, inexpensive, accurate, and robust, and, most importantly, must provide sufficiently comprehensive information about the person’s health such that therapies can be adjusted based on valid physiological relationships.

In terms of monitoring CVD at home, such a comprehensive assessment would require information regarding both the electrical and mechanical aspects of cardiovascular function. However, current technologies for unobtrusively assessing the mechanical aspects are greatly limited, and in general not amenable for home use [10]. Ballistocardiography (BCG), the measurement of the mechanical forces of the body in reaction to cardiac ejection of blood [11]–[13], has shown promise in recent studies for offering a possible solution to this technological need. Robust BCG measurements have been demonstrated using beds [14], [15], chairs [16], and modified home weighing scales [13], and were shown to correlate strongly to changes in cardiac output [10], contractility [17], [18], and beat-by-beat left ventricular function [13]—all three of these representing central aspects of mechanical function.

Continuous measurement of BCG signals using a wearable device would greatly enhance the capabilities of the technique for assessing cardiovascular health at home. If BCG signals were continuously obtained throughout the day and night, then specific responses of cardiac output and contractility to perturbations such as ambient temperature [19], posture [20], activity

[21], and sleep [22] could be gathered, and a more comprehensive picture of the person's cardiovascular health could be obtained. Accordingly, researchers have developed wearable systems based on miniature accelerometers to attempt to measure BCG signals continuously [23], [24]. However, since the morphology and timing of these signals are significantly different from BCG signals measured using the weighing scale [25], or other historical techniques such as the Starr Table [11], the analysis and interpretation techniques developed for BCG signals should not directly be applied to these wearable acceleration measurements. For example, while the time interval between the electrocardiogram (ECG) R-wave peak and the BCG J-wave peak—the R–J interval—was typically 250 ms for a healthy adult [17] measured with the static-charge-sensitive bed apparatus, and ranged from 203–290 ms for 92 healthy subjects participating in a study with the weighing scale system [26], for the accelerometer-based wearable system the R–J interval was found to be between 150–180 ms [23]. Similar results were found by Wiard *et al.*, with an accelerometer-based BCG system where the R–J interval was 133 ms [27].

Cardiac timing measurements such as the R–J interval are clinically important for a number of reasons. Calcium ions regulate contractility and relaxation of the heart, and recycling of these ions controls the timing of cardiac events. Regulation of calcium ions is thus critically important in mechanical dysfunction and arrhythmia [28]. Since cardiac timing exhibits millisecond precision, it is a good measure of myocardial cellular health, and irregularities in timing measurements are generally the first indication of problems in cardiac performance [29].

This paper builds on preliminary results from [30], and presents a systematic approach for elucidating the relationship between these surface vibrations of the body in the head-to-foot direction, and the movements of the whole body as measured by the BCG-equipped weighing scale. Additionally, a methodology is proposed for mathematically converting the wearable acceleration signals to BCG signals such that the same analysis and interpretation tools can be used for both measurements. Finally, to the best of our knowledge, this represents the first high-resolution (low electronic noise) measurements of the surface accelerations of the body related to the heartbeat with a low weight accelerometer which will minimally load the measurement in the transverse direction.

## II. METHODS AND DESIGN APPROACH

### A. Hardware Design and Data Collection

This study was conducted under a protocol reviewed and approved by the Georgia Institute of Technology Institutional Review Board. All subjects provided informed consent before experimentation. Fifteen healthy subjects were recruited for this study, including ten men and five women with ages ranging from 22 to 57. Similar to other studies in the existing literature, each subject served as his or her own control since relationships between measurements made on the same individuals were examined [31]–[33].

Fig. 1 shows the block diagram of the measurement hardware and setup, as well as representative signals measured from

one subject. As shown in Fig. 1(a), a custom circuit was built and implanted in the modified home weighing scale (BC534, Tanita Corporation, Tokyo, Japan) to interface to the strain gauge bridge in the scale and measure the fluctuations in body-weight caused by the heartbeat—the head-to-foot BCG signal. An ultralow noise integrated bridge amplifier and 24-bit sigma-delta analog-to-digital converter (AD7191, Analog Devices, Norwood, MA, USA) was used to amplify this differential signal from the strain gauge bridge, and the digitized output was connected to the input port of a microcontroller (1284P, Atmel Corporation, San Jose, CA, USA). The digitized signal, sampled at 120 Hz, was then wirelessly transmitted to the computer using Bluetooth and stored for postprocessing and analysis. For further details on the BCG measurement hardware the reader is referred to previous work [13].

The ECG recordings were measured by the BN-EL50 wireless ECG measurement module (BIOPAC Systems, Inc., Goleta, CA, USA) with the Ag/AgCl surface electrodes configured for a modified Lead II measurement. The ECG data were transmitted wirelessly from this module to the data acquisition system (MP150WSW, BIOPAC Systems, Inc., Goleta, CA), where they were sampled at 1 kHz and stored on the computer.

While the subjects stood on the weighing scale and the BCG and ECG were recorded, the surface acceleration signals in the head-to-foot direction were measured using a small, ultralow noise accelerometer (356A32, PCB Piezotronics, Depew, NY, USA) attached to various locations on the torso. This accelerometer was selected based on its low spot noise ( $20 \mu\text{g}_{\text{rms}}/\sqrt{\text{Hz}}$  at 10 Hz) and total noise ( $300 \mu\text{g}_{\text{rms}}$  for a bandwidth of 1–10 000 Hz), wide signal bandwidth (0.7–5000 Hz,  $\pm 1$  dB), and its relatively small size (11.4 mm cubed) and low weight (5.4 g). In contrast to micromachined (microelectromechanical systems, MEMS) accelerometers used in previous studies, the self-noise was several times lower: the LIS344ALH (ST Microelectronics, Geneva, Switzerland) accelerometer used in previous studies [24], [34] represents the lowest noise MEMS accelerometer available, with a self-noise of  $350 \mu\text{g}_{\text{rms}}$  for a bandwidth of 1–50 Hz compared to the  $60 \mu\text{g}_{\text{rms}}$  for the 356A32 used here. Compared to other instrumentation-grade accelerometers used in previous work, the weight of our accelerometer was 8x lower, as was the volume: the 4381 (Bruel & Kjaer, Naerum, Denmark) piezoelectric accelerometer used previously [35], [36] weighs 43 g and is a 20.5 mm diameter  $\times$  23.6 mm height cylinder compared to the 5.4 g weight and 11.4-mm-cubed dimensions of the sensor used here.

These choices of accelerometers for previous studies have been driven by the fact that the analysis was focused primarily on dorso-ventral components of cardiogenic surface accelerations of the torso, as compared to head-to-foot components. The dorso-ventral components are larger in amplitude, and, due to the measurement direction being perpendicular to the wall of the chest, mechanical loading of the skin by the sensor would be of less concern. Since our study focuses on head-to-foot accelerations, and the subjects are standing upright, the loading of the skin by a heavy accelerometer would be of great concern, as would an elevated sensor noise floor compromising the accuracy of our measurements. Based on these aspects, we argue

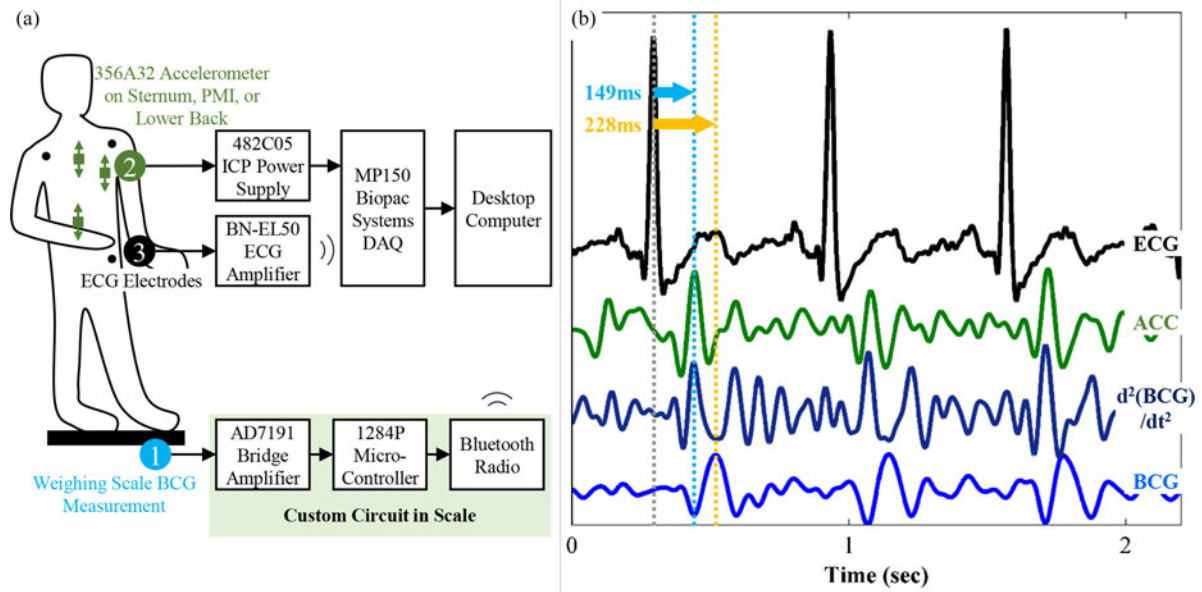

Fig. 1. (a) Block diagram of measurement setup showing three main accelerometer placement locations analyzed in this paper, after [30]. (b) Representative electrocardiogram (ECG), head-to-foot acceleration (ACC), second-derivative of the ballistocardiogram ( $d^2(BCG)/dt^2$ ), and ballistocardiogram (BCG) measurements from one subject. For this recording, the accelerometer was placed on the subject's sternum. The time delays from the ECG R-wave to the main peak of the acceleration and second-derivative BCG signals were identical, at 149 ms, while the time delay from the ECG R-wave to the BCG J-wave peak (R-J interval) was 228 ms, consistent with physiological expectations.

that the waveforms presented in this paper, are the closest representation of the actual surface accelerations in the head-to-foot direction, of high-signal quality as shown in Fig. 1(b), and are the most appropriate surface measurements for comparison to BCG recordings from the weighing scale system.

### B. BCG, ECG, and Accelerometer Signal Processing

The signal processing consisted of preprocessing for reducing electronic noise, baseline wander, and motion artifacts in the signals, and feature extraction from the BCG and acceleration signals. The feature extraction operations are summarized in the block diagram shown in Fig. 2.

The ECG signal was digitally band-pass filtered (Finite impulse response, FIR, Pass-band: 15-25 Hz, Kaiser window) to extract the QRS complexes, then a simple automatic peak detection algorithm was employed and checked manually to find the R-wave timings. The BCG was band-pass filtered (FIR, Pass-band: 0.8–15 Hz, Kaiser window) to remove baseline wander and high-frequency noise, as was the acceleration signal (Infinite impulse response, IIR, Pass-band: 1–15 Hz, Butterworth). Using the R-wave peaks as a fiduciary point, the BCG and acceleration waveforms were then segmented with a window extending from each R-wave peak timing  $R_i$  to  $R_i + 700$  ms. The ensemble averages were then computed from these segmented heartbeats. The acceleration ensemble average was then double integrated using a twice-repeated sequence of trapezoidal integration and low-order polynomial-fitting-based baseline wander estimation and subsequent removal. For each subject, and each location on the torso, a normalized residual rms error was then found from the double-integrated acceleration signal compared to the BCG,

with a scaling factor first determined based on the ratio of the maximum absolute value amplitude of the signals; a correlation coefficient was also computed.

The R-J interval was calculated for the weighing-scale BCG signal by finding the elapsed time between the previous ECG R-wave peak and the global maximum in the first 400 ms of the BCG ensemble average. The 400-ms window was chosen based on physiological expectations and previous values for normal R-J intervals from the existing literature. The interval between the ECG R-wave and the maximum peak of the vibration signal was measured for the head-to-foot accelerometer signal, and the double-integral of the acceleration, as follows. In our initial observations of the double-integrated acceleration signals, we noticed that simply using the global maximum over the full window created errors in J-wave peak detection due to the double integration operation amplifying low-frequency noise.

One source of low-frequency noise is motion or postural sway of the subject. It is known that the standing BCG is more prone to noise from subject motion than stationary techniques such as bed- and chair-based BCG methods where the subject is either supine or seated [16], [37]. Techniques have been developed to reduce this noise in the standing BCG using electromyogram (EMG) signals from the feet as a measure of lower body muscle contraction and relaxation [25], [38]. Other sources of noise affecting the measurement include low-frequency electrical noise. The low-frequency parasitic components from these various sources were shaped by the double integration.

As a result, we created a simple algorithm to find the closest large peak to the actual BCG J peak rather than the global maximum. To achieve this, first the indices of all *local* maxima were located in the first 400 ms of the acceleration ensemble

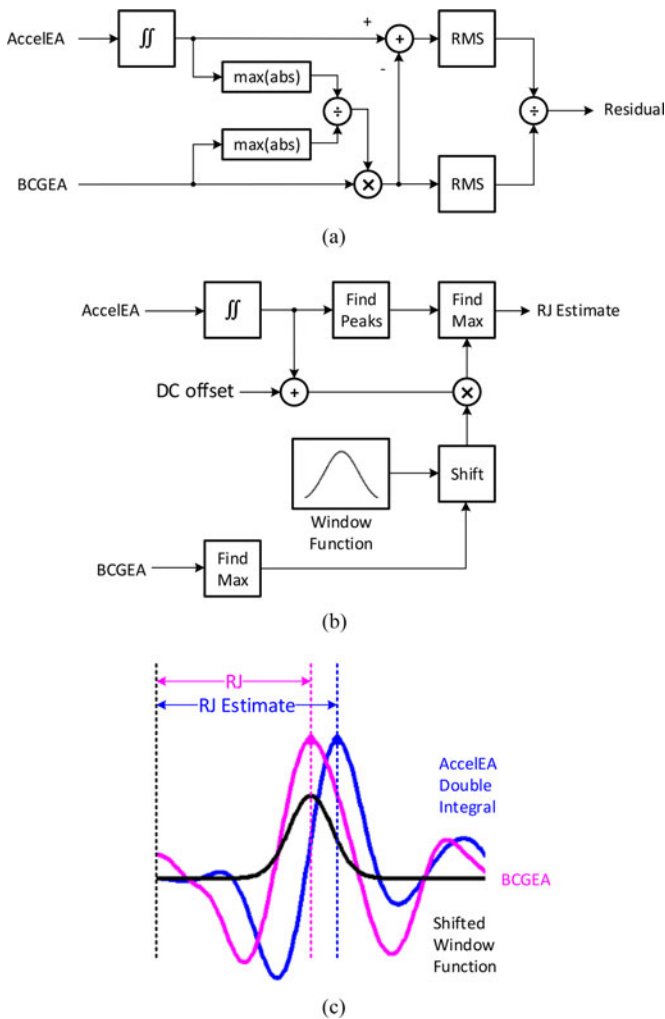

Fig. 2. Block diagram describing the signal processing methods for estimating the normalized residual (a), and the R–J interval (b) from the double-integrated acceleration and BCG signals (c).

average. Then, the acceleration ensemble average was offset with a positive dc bias and multiplied by a Gaussian window function centered on the true J-wave peak. This signal was evaluated at the samples corresponding to the local maxima and the absolute maximum among them was selected as the best estimate for the J-wave peak. In this way, the estimated J-wave peak was located with preference *first* to peaks that were closest to the true J-wave peak and *then* for peaks that were large. A large peak in the acceleration signal that was slightly farther from the true J peak will be selected over a much smaller peak closer to the true J-wave with the width of the Gaussian window function determining the balance between peak size and distance from true J-wave. Additionally, an analysis of these error metrics against heart rate was performed, and no significant correlations were found.

### C. Experiments and Statistical Analysis

For one subject with representative acceleration and BCG waveform amplitude and morphology, we measured triaxial ac-

celeration signals from several locations on the torso and head and plotted them for visual analysis and comparison.

For all subjects, we measured the head-to-foot accelerations at three locations—sternum, point of maximal impulse (PMI), and lower back (center of mass, COM)—simultaneously with the ECG and BCG. We determined the best location for each subject based on the lowest normalized residual and the highest correlation coefficient. We assessed the statistical significance (at the  $p < 0.05$  level) of the differences in both normalized residuals and correlation coefficients for the different locations for all subjects using Student’s  $t$ -test. For the R–J intervals, we used Bland–Altman methods [39] to assess the agreement between the two accelerometer-derived R–J intervals (one from the acceleration signal itself, and one from the double-integrated acceleration signal) and the BCG-derived “gold” standard R–J interval. We compared the bias and confidence interval for both of these techniques, and determined whether or not a body-worn accelerometer combined with ECG could yield an accurate estimate of the R–J interval.

## III. RESULTS

### A. Influence of Sensor Placement on Signal Morphology and Timing: Results From One Subject

The ensemble averaged acceleration waveforms in all three axes—with  $x$  as lateral,  $y$  as dorso-ventral, and  $z$  as head-to-foot directions—are shown in Fig. 3 alongside the simultaneously acquired ECG and BCG signals for one subject. Note that the head-to-foot acceleration is greatest at the PMI, and decreases at the sternum and lower back. For the dorso-ventral direction, the time delay between the ECG R-wave and the largest negative peak in the acceleration waveform is shortest at the sternum, and the PMI, then longest at the lower back. The recording from the ear appears to be the smallest in terms of peak-to-peak accelerations, and is delayed in time compared to the sternal signal.

### B. Statistical Results From All Subjects

Table I shows the normalized residual and correlation coefficient values for all subjects for the three positions. The position with the lowest residual is denoted by an asterisk (\*), and the position with the highest correlation coefficient by a dagger (†). The PMI was the best location in terms of lowest residual and highest correlation coefficient for only three of the fifteen subjects; the lower back was the best location in terms of lowest residual for three of fifteen subjects, but highest correlation coefficient for six subjects. The sternum was the best location of the three, with significantly lower normalized residual compared to the PMI and lower back for the overall subject population ( $p < 0.05$ ). Considering only the results from the best of three locations for all subjects, the average ( $\pm\sigma$ ) normalized residual and correlation coefficient are  $0.83 (\pm 0.22)$  and  $0.83 (\pm 0.07)$ . Finally, following the trend shown in Fig. 3 for one subject, the peak-to-peak acceleration amplitude was significantly ( $p = 0.01$ ) highest on average for all subjects with the sensor placed at the PMI ( $61.3 \pm 26.8$  mg), then the

TABLE I  
RESULTS FOR ALL SUBJECTS

Subject	Demographics			Sternum			PMI			Lower Back			HR		
	Gdr.	Ht. (cm)	Wt. (kg)	Age (yrs)	Norm. Resid.	Coef.	Num. Beats	Norm. Resid.	Coef.	Num. Beats	Norm. Resid.	Coef.	Num. Beats	Avg. BPM	$\sigma$
1	M	178	60	23	1.07	0.60	88	0.94*	0.76†	82	1.30	0.50	87	72.7	5.2
2	M	175	69	22	1.25	0.44	81	1.19*	0.73†	78	1.55	0.72	87	76.7	5.0
3	F	160	49	22	1.08	0.67	63	1.54	0.74	59	1.03*	0.76†	73	83.6	4.7
4	M	185	105	22	0.83	0.68	77	1.01	0.85	86	0.72*	0.87†	85	90.7	3.4
5	M	196	98	23	0.92*	0.64	82	1.31	0.74	63	1.24	0.78†	42	84.8	3.4
6	M	178	89	32	0.86*	0.76	77	1.19	0.56	77	0.92	0.82†	77	77.9	3.0
7	M	185	73	23	0.83	0.80	101	1.08	0.74	94	0.70*	0.88†	101	72.3	3.7
8	F	172	52	37	1.00*	0.72†	56	1.36	0.59	59	1.13	0.70	53	78.7	4.6
9	M	180	85	26	0.57*	0.91†	59	0.92	0.72	60	0.69	0.85	65	88.1	5.7
10	F	165	53	48	0.63*	0.81†	23	1.44	0.69	52	0.79	0.73	43	100.6	5.9
11	M	182	85	37	0.58*	0.89†	68	1.14	0.85	70	0.98	0.78	65	100.0	5.8
12	F	165	53	22	0.77*	0.84	67	1.45	0.92†	72	1.19	0.66	69	97.8	5.3
13	F	160	61	57	1.34	0.74†	63	1.23*	0.40	66	1.27	0.37	68	97.4	4.1
14	M	180	78	32	0.75*	0.78	55	1.22	0.45	63	1.04	0.87†	65	90.6	4.6
15	M	173	68	24	0.51*	0.91†	85	0.87	0.74	78	1.20	0.82	81	87.4	4.3
Avg.	–	175.6	71.9	30	0.87*	0.75†	69.7	1.19	0.7	70.6	1.05	0.74	70.7	86.6	4.6
$\sigma$	–	10.1	17.7	10.7	0.25	0.13	18.4	0.2	0.14	11.7	0.25	0.14	16.5	9.6	0.92
Min	–	160	49	22	0.51	0.44	23	0.87	0.4	52	0.69	0.37	42	72.3	3
Max	–	196	105	57	1.34	0.91	101	1.54	0.92	94	1.55	0.88	101	100.6	5.9

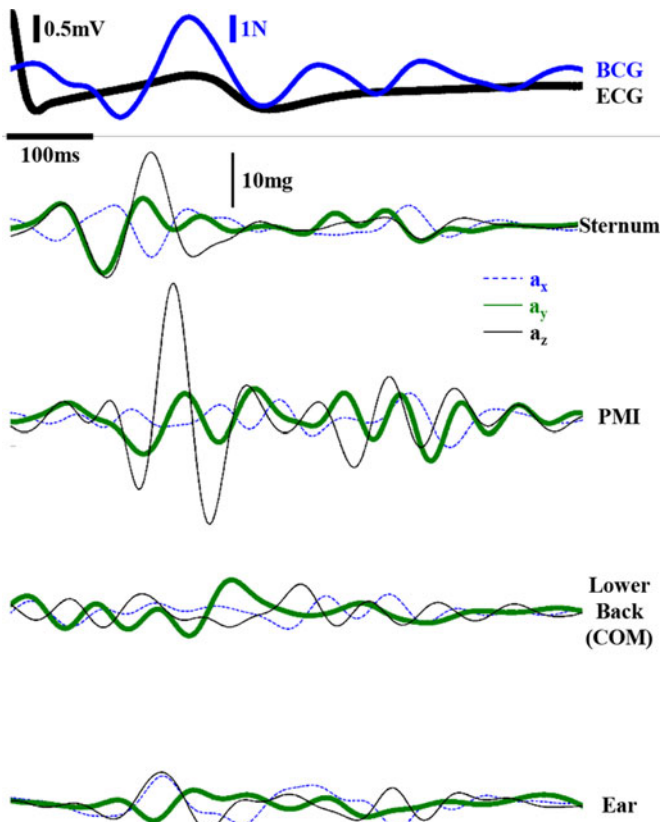

Fig. 3. Ensemble averaged ECG and BCG (top), and triaxial acceleration waveforms for one subject with the accelerometer placed at the sternum, PMI, lower back (COM), and ear. All signals are shown on the same  $x$ -axis (time), the ECG and BCG scale bars are shown for their respective amplitudes, and the 10 mg amplitude scale bar applies to all acceleration signals.

sternum ( $32.6 \pm 12.6$  mg), then the back ( $16.3 \pm 10.5$  mg), and the minimum location occurred significantly later ( $p < 0.05$ ) in the cardiac cycle at the lower back ( $224.0 \pm 35.8$  ms) compared to the sternum ( $176.2 \pm 81.1$  ms).

### C. R–J Interval Comparisons

Fig. 4 shows three Bland–Altman plots of agreement between the “gold” standard R–J interval measurement (the interval between the ECG R-wave and the weighing scale BCG J-wave) and the acceleration or double-integrated acceleration waveforms from all three locations on the body. With the accelerometer located at the sternum or lower back, the R–J interval derived using the double-integrated acceleration signal showed good agreement with the weighing scale. The best location for R–J interval estimation was found to be the lower back, with a bias of  $-3.9$  ms and a confidence interval of  $\pm 30$  ms. Using the acceleration waveform itself provided poor agreement with weighing scale R–J intervals, with both a large bias and wide confidence interval.

## IV. DISCUSSION

The results show that although a body-mounted accelerometer can be used for BCG measurement, the acceleration waveform itself should not be interpreted using standard BCG nomenclature or feature extraction techniques. Rather, a simple ensemble averaging and double integration operation can be used to transform the acceleration waveform into a COM BCG signal, from which standard BCG feature extraction techniques can be applied. Additionally, although accelerations measured at the PMI have the largest *amplitude*—and thus the highest electronic signal-to-noise ratio (SNR)—the PMI is the *worst* location for both matching the BCG signal morphology and for extracting

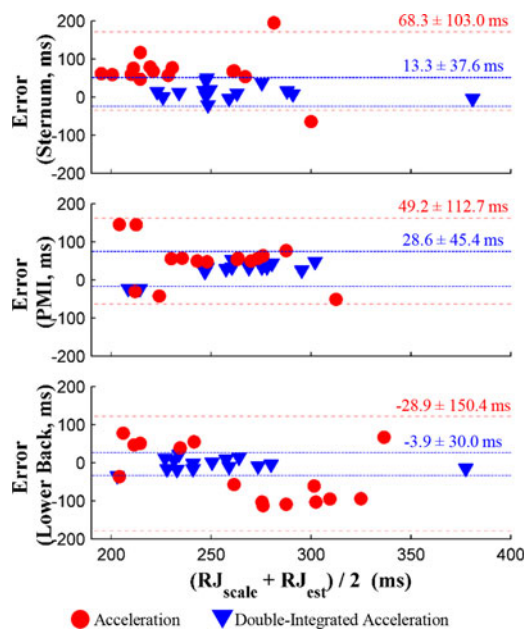

Fig. 4. Bland Altman plots showing agreement between ECG R-wave to BCG J-wave intervals derived from the weighing scale BCG signal (“gold” standard) compared to corresponding R–J intervals derived from the acceleration and double-integrated acceleration waveforms measured at the sternum, PMI, and lower back. For each location, the confidence intervals (95%) are also plotted for each estimate, and the bias  $\pm$  confidence interval are shown. The best agreement was found in the lower back measurement, after taking the double integral of the head-to-foot acceleration waveform. Using the acceleration waveform itself always resulted in poorer bias and confidence interval for R–J interval estimation.

the R–J interval feature. This reinforces the importance of optimizing physiological sensing systems and approaches based on the physiology and findings from human subjects studies, rather than using engineering principles alone.

The best location for placing the accelerometer for wearable BCG measurements is subject dependent, indicating that for optimal results an initial calibration step may be needed. For example, a subject could stand on the BCG-equipped weighing scale while wearing an accelerometer on the torso, and the transfer function between the measurements could be modeled mathematically. For most measurements, the sternum is the best location for mounting the sensor, as it produced the lowest average residual (best morphological match) compared to the COM BCG and accurate R–J interval feature extraction. For applications requiring best timing precision in assessing the R–J interval, the lower back placement should be used: this positions the accelerometer as closely as possible to the COM of the person, thus closely mirroring the COM movements which are measured with the scale.

Finally, these results suggest that in addition to the hemodynamic components at the origin of these low frequency (<20 Hz) vibration signals of the torso, there are other components that are localized at the heart: for example, the movement of the heart itself. This has been suggested previously in the existing literature [40], and is now further reinforced by these experimental results.

## V. CONCLUSION

This paper presents a novel methodology that can be used to extract clinically relevant BCG features based on acceleration measurements from different locations on the torso, and provides promising evidence for these methods based on preliminary findings from human subjects studies. The proposed methodology can potentially reduce some of the confusion in the scientific community regarding the relationship between traditional “fixed” BCG measurements and wearable BCG measurements, and reiterates the importance of sensor placement for interpreting results.

While the results of this study appear promising, a few limitations should be mentioned. Although double integration improved the accuracy of the R–J interval measurement, and therefore, the measurement of changes in contractility, this method has not been validated for patients with heart failure or other cardiac abnormalities. Additionally, the standing BCG method used in this study can exhibit more noise from motion and postural sway than BCG methods for which the patient is seated or supine. In future work, the ability to track hemodynamic and timing interval modulation during exercise or other physiological changes will be quantified.

## REFERENCES

- [1] A. S. Go, D. Mozaffarian, V. L. Roger, E. J. Benjamin, J. D. Berry, M. J. Blaha, S. Dai, E. S. Ford, C. S. Fox, S. Franco, H. J. Fullerton, C. Gillespie, S. M. Hailpern, J. A. Heit, V. J. Howard, M. D. Huffman, S. E. Judd, B. M. Kissela, S. J. Kittner, D. T. Lackland, J. H. Lichtman, L. D. Lisabeth, R. H. Mackey, D. J. Magid, G. M. Marcus, A. Marelli, D. B. Matchar, D. K. McGuire, E. R. Mohler, 3rd, C. S. Moy, M. E. Mussolino, R. W. Neumar, G. Nichol, D. K. Pandey, N. P. Paynter, M. J. Reeves, P. D. Sorlie, J. Stein, A. Towfighi, T. N. Turan, S. S. Virani, N. D. Wong, D. Woo, and M. B. Turner, “Heart disease and stroke statistics—2014 update: A report from the American heart association,” *Circulation*, vol. 129, pp. e28–e292, 2014.
- [2] P. A. Heidenreich, J. G. Trogon, O. A. Khavjou, J. Butler, K. Dracup, M. D. Ezekowitz, E. A. Finkelstein, Y. Hong, S. C. Johnston, A. Khera, D. M. Lloyd-Jones, S. A. Nelson, G. Nichol, D. Orenstein, P. W. F. Wilson, and Y. J. Woo, “Forecasting the future of cardiovascular disease in the united states: A policy statement from the American heart association,” *Circulation*, vol. 123, pp. 933–944, Mar. 1, 2011.
- [3] R. A. Cooper, T. E. Getzen, H. J. McKee, and P. Laud, “Economic and demographic trends signal an impending physician shortage,” *Health Affairs*, vol. 21, pp. 140–154, Jan. 1, 2002.
- [4] J. Buchan, “Nurse migration and international recruitment,” *Nursing Inquiry*, vol. 8, pp. 203–204, 2001.
- [5] P. I. Buerhaus, D. O. Staiger, and D. I. Auerbach, “Implications of an aging registered nurse workforce,” *J. Amer. Med. Assoc.*, vol. 283, pp. 2948–2954, 2000.
- [6] G. Pare, M. Jaana, and C. Sicotte, “Systematic review of home telemonitoring for chronic diseases: The evidence base,” *J. Amer. Med. Assoc.*, vol. 14, pp. 269–277, 2007.
- [7] L. R. Goldberg, J. D. Piette, M. N. Walsh, T. A. Frank, B. E. Jaski, A. L. Smith, R. Rodriguez, D. M. Mancini, L. A. Hopton, E. J. Orav, and E. Loh, “Randomized trial of a daily electronic home monitoring system in patients with advanced heart failure: The weight monitoring in heart failure WHARF trial,” *Amer. Heart J.*, vol. 146, pp. 705–712, 2003.
- [8] T. G. Pickering, N. H. Miller, G. Ogedegbe, L. R. Krakoff, N. T. Artinian, and D. Goff, “Call to action on use and reimbursement for home blood pressure monitoring: A joint scientific statement from the American heart association, American society of hypertension, and preventive cardiovascular nurses association,” *Hypertension*, vol. 52, pp. 10–29, Jul. 1, 2008.

- [9] M. A. Konstam, "Home monitoring should be the central element in an effective program of heart failure disease management," *Circulation*, vol. 125, pp. 820–827, Feb. 14, 2012.
- [10] O. T. Inan, M. Etemadi, A. Paloma, L. Giovangrandi, and G. T. A. Kovacs, "Non-invasive cardiac output trending during exercise recovery on a bathroom-scale-based ballistocardiograph," *Physiol. Meas.*, vol. 30, pp. 261–274, 2009.
- [11] I. Starr, A. J. Rawson, H. A. Schroeder, and N. R. Joseph, "Studies on the estimation of cardiac output in man, and of abnormalities in cardiac function, from the heart's recoil and the blood's impacts; the ballistocardiogram," *Amer. J. Physiol.*, vol. 127, pp. 1–28, 1939.
- [12] H. R. Brown, *Clinical Ballistocardiography*. New York, NY, USA: Macmillan, 1952.
- [13] O. T. Inan, M. Etemadi, R. M. Wiard, L. Giovangrandi, and G. T. A. Kovacs, "Robust ballistocardiogram acquisition for home monitoring," *Physiol. Meas.*, vol. 30, p. 169, 2009.
- [14] B. H. Jansen, B. H. Larson, and K. Shankar, "Monitoring of the ballistocardiogram with the static charge sensitive bed," *IEEE Trans. Biomed. Eng.*, vol. 38, no. 8, pp. 748–751, Aug. 1991.
- [15] J. Paalasmaa, M. Waris, H. Toivonen, L. Leppakorpi, and M. Partinen, "Unobtrusive online monitoring of sleep at home," in *Proc. IEEE Annu. Int. Conf. Eng. Med. Biol. Soc.*, 2012, pp. 3784–3788.
- [16] T. Koivistoinen, S. Junnila, A. Varri, and T. Koobi, "A new method for measuring the ballistocardiogram using EMFi sensors in a normal chair," in *Proc. IEEE 26th Annu. Int. Conf. Eng. Med. Biol. Soc.*, 2004, pp. 2026–2029.
- [17] A. Lindqvist, K. Pihlajamäki, J. Jalonen, V. Laaksonen, and J. Alihanka, "Static-charge-sensitive bed ballistocardiography in cardiovascular monitoring," *Clin. Physiol.*, vol. 16, pp. 23–30, 1996.
- [18] M. Etemadi, O. T. Inan, L. Giovangrandi, and G. T. A. Kovacs, "Rapid assessment of cardiac contractility on a home bathroom scale," *IEEE Trans. Inform. Technol. Biomed.*, vol. 15, no. 6, pp. 864–869, Nov. 2011.
- [19] L. B. Rowell, H. J. Marx, R. A. Bruce, R. D. Conn, and F. Kusumi, "Reductions in cardiac output, central blood volume, and stroke volume with thermal stress in normal men during exercise," *J. Clin. Invest.*, vol. 45, pp. 1801–1816, 1966.
- [20] J. McMichael and E. P. Sharpey-Schafer, "Cardiac output in man by direct Fick method: Effects of posture, venous pressure change, atropine, and adrenaline," *Brit. Heart J.*, vol. 6, pp. 33–40, 1944.
- [21] V. F. Froelicher and J. Myers, *Exercise and the Heart*, 5th ed. Philadelphia, PA, USA: Saunders, 2006.
- [22] I. M. Khatri and E. D. Freis, "Hemodynamic changes during sleep," *J. Appl. Physiol.*, vol. 22, pp. 867–73, May 1, 1967.
- [23] D. D. He, E. S. Winokur, and C. G. Sodini, "A continuous, wearable, and wireless heart monitor using head ballistocardiogram (BCG) and head electrocardiogram (ECG)," in *Proc. IEEE Annu. Int. Conf. Eng. Med. Biol. Soc.*, 2011, pp. 4729–4732.
- [24] P. Castiglioni, A. Faini, G. Parati, and M. Di Rienzo, "Wearable seismocardiography," in *Proc. IEEE 29th Annu. Int. Conf. Eng. Med. Biol. Soc.*, 2007, pp. 3954–3957.
- [25] O. T. Inan, P. Dookun, L. Giovangrandi, and G. T. A. Kovacs, "Noninvasive measurement of physiological signals on a modified home bathroom scale," *IEEE Trans. Biomed. Eng.*, vol. 59, no. 8, pp. 2137–2143, Aug. 2012.
- [26] O. T. Inan, "Novel technologies for cardiovascular monitoring using ballistocardiography and electrocardiography," Ph.D. dissertation, Dept. Elect. Eng., Stanford University, Stanford, CA, USA, 2009.
- [27] R. M. Wiard, O. T. Inan, L. Giovangrandi, C. M. Cuttino, and G. T. A. Kovacs, "Preliminary results from standing ballistocardiography measurements in microgravity," in *Proc. IEEE 35th Annu. Int. Conf. Eng. Med. Biol. Soc.*, 2013, pp. 7290–7293.
- [28] R. M. Berne and M. N. Levy, *Cardiovascular Physiology*, 7th ed. St. Louis, MO, USA: Mosby, 1997.
- [29] A. M. Weissler, W. S. Harris, and C. D. Schoenfeld, "Systolic time intervals in heart failure in man," *Circulation*, vol. 37, pp. 149–159, 1968.
- [30] A. Wiens, M. Etemadi, L. Klein, S. Roy, and O. T. Inan, "Wearable ballistocardiography: Preliminary methods for mapping surface vibration measurements to whole body forces," presented at the *IEEE Eng. Med. Biol. Conf.*, Chicago, IL, USA, 2014.
- [31] C. Bruser, K. Stadthanner, S. De Waele, and S. Leonhardt, "Adaptive beat-to-beat heart rate estimation in ballistocardiograms," *IEEE Trans. Inf. Technol. Biomed.*, vol. 15, no. 5, pp. 778–786, Sep. 2011.
- [32] H. Baek, G. S. Chung, K. Kim, and K. S. Park, "A smart health monitoring chair for noninvasive measurement of biological signals," *IEEE Trans. Inf. Technol. Biomed.*, vol. 16, no. 1, pp. 150–158, Jan. 2012.
- [33] C. A. Wick, J.-J. Su, J. H. McClellan, O. Brand, P. T. Bhatti, A. L. Buice, A. E. Stillman, X. Tang, and S. Tridandapani, "A system for seismocardiography-based identification of quiescent heart phases: Implications for cardiac imaging," *IEEE Trans. Inf. Technol. Biomed.*, vol. 16, no. 5, pp. 869–877, Sep. 2012.
- [34] K. Pandia, O. T. Inan, G. T. A. Kovacs, and L. Giovangrandi, "Extracting respiratory information from seismocardiogram signals acquired on the chest using a miniature accelerometer," *Physiol. Meas.*, vol. 33, no. 10, pp. 1643–1640, Oct. 2012.
- [35] B. Ngai, K. Tavakolian, A. Akhbardeh, A. P. Blaber, B. Kaminska, and A. Noordergraaf, "Comparative analysis of seismocardiogram waves with the ultra-low frequency ballistocardiogram," in *Proc. IEEE Annu. Int. Conf. Eng. Med. Biol. Soc.*, 2009, pp. 2851–2854.
- [36] W. P. McKay, P. H. Gregson, B. W. McKay, and J. Miltzer, "Sternal acceleration ballistocardiography and arterial pressure wave analysis to determine stroke volume," *Clin. Invest. Med.*, vol. 22, pp. 4–14, 1999.
- [37] D. C. Mack, J. T. Patrie, P. M. Suratt, R. A. Felder, and M. Alwan, "Development and preliminary validation of heart rate and breathing rate detection using a passive, ballistocardiography-based sleep monitoring system," *IEEE Trans. Inf. Technol. Biomed.*, vol. 13, no. 1, pp. 111–120, Jan. 2009.
- [38] O. T. Inan, G. T. A. Kovacs, and L. Giovangrandi, "Evaluating the lower-body electromyogram signal acquired from the feet as a noise reference for standing ballistocardiogram measurements," *IEEE Trans. Inf. Technol. Biomed.*, vol. 14, no. 5, pp. 1188–1196, Sep. 2010.
- [39] J. M. Bland and D. G. Altman, "Statistical methods for assessing agreement between two methods of clinical measurement," *Lancet*, vol. 327, pp. 307–310, 1986.
- [40] M. D. Rienzo, E. Vaini, P. Castiglioni, G. Merati, P. Meriggi, G. Parati, A. Faini, and F. Rizzo, "Wearable seismocardiography: Towards a beat-by-beat assessment of cardiac mechanics in ambulant subjects," *Autonomic Neuroscience*, vol. 178, pp. 50–59, 2013.



**Andrew D. Wiens** (S'10) received the B.S. degree in electrical engineering and computer engineering with honors from Washington University, St. Louis, MO, USA, in 2013. He is currently working toward the Ph.D. degree.

He came to the Department of Electrical and Computer Engineering at Georgia Institute of Technology as a Teaching Assistant in digital signal processing the same year, and in 2014 he became a Teaching Assistant in electromagnetics. He is currently a Research Assistant in Dr. Omer Inan's lab. His current research interests include bioengineering, signal processing, machine learning, and techniques for noninvasive physiological measurements.

Mr. Wiens received the President's Scholarship in 2013 from the Georgia Institute of Technology.



**Mozziyar Etemadi** (S'07) received the B.S. and M.S. degrees in electrical engineering from Stanford University, Stanford, CA, USA, in 2008 and June 2009, respectively. He received the Ph.D. degree in bioengineering from the University of California, San Francisco (UCSF)/UC Berkeley Joint Graduate Group in Bioengineering in 2013, as part of the joint M.D./Ph.D. program.

He is on a short leave from the M.D./Ph.D. program, and is currently a postdoctoral scholar jointly mentored between UCSF Bioengineering and Therapeutic Sciences and UC Berkeley Electrical Engineering and Computer Sciences. His current research interests include translational biomedical engineering for in-home monitoring of disease and biomedical instrumentation for fetal surgery.

Dr. Etemadi was named Forbes Magazine's "Top 30 Under 30" in Science in January 2012. Later that year, Dr. Etemadi was awarded the Center for Integration of Medicine and Innovative Technology (CIMIT) Prize for Primary Care Innovation, and the grand prize in the Dow Sustainability Student Innovation Challenge. In 2011, he helped lead a research team awarded second prize in the Vodafone Americas Wireless Innovation Challenge and the mHealth Alliance Award. While at Stanford University in 2009, he received the Frederick E. Terman Award for Scholastic Achievement in Engineering and also received the Electrical Engineering Fellowship, providing full support for his graduate studies.





**Shuvo Roy** (M'96) received the B.S. degree, *magna cum laude*, with general honors for triple majors in physics, mathematics (special honors), and computer science from Mount Union College, Alliance, OH, USA, in 1992. He received the M.S. degree in electrical engineering and applied physics and the Ph.D. degree in electrical engineering and computer science from Case Western Reserve University, Cleveland, OH, in 1995 and 2001, respectively.

He is currently an Associate Professor in the Department of Bioengineering and Therapeutic Sciences (BTS), a joint department of the Schools of Pharmacy and Medicine, the University of California, San Francisco (UCSF), and the Director of the UCSF Biomedical Microdevices Laboratory. He holds the Harry Wm. and Diana V. Hind Distinguished Professorship in Pharmaceutical Sciences II in the UCSF School of Pharmacy. He is also a Founding Member of the UCSF Pediatric Devices Consortium, which has a mission to accelerate the development of innovative devices for children's health, and a faculty affiliate of the California Institute for Quantitative Biosciences. From 1998 to 2008, he was the Codirector of the BioMEMS Laboratory, Department of Biomedical Engineering, Cleveland Clinic, Cleveland, OH, where he worked with basic scientists, practicing clinicians, and biomedical engineers to develop MEMS solutions to high-impact medical challenges. While working for the doctorate degree, he conducted research in the areas of design, microfabrication, packaging, and performance of MEMS for harsh environments. He also investigated microstructural characteristics and mechanical properties of MEMS materials, developed the requisite microfabrication technologies, and demonstrated operation of the first surface micromachined silicon carbide transducers at high temperatures (up to 950 °C). He has also developed miniaturized microrelays for high-performance electrical switching and ice detection sensors for aerospace applications. He joined UCSF in 2008 to continue the development of biomedical devices including wireless physiological monitoring systems and bioartificial replacement organs, and participate in the training of professional students in the School of Pharmacy as well as graduate students in the UCSF/UCB Joint Graduate Group in bioengineering.

Dr. Roy is an Associate Editor of biomedical microdevices and an Editorial Board member of Sensors and Materials. He has contributed more than 90 technical publications, coauthored three book chapters, been awarded 16 U.S. patents, and given more than 70 invited presentations. He received Top 40 under 40 award by Crains Cleveland Business in 1999 and the Clinical Translation Award at the 2nd Annual BioMEMS and Biomedical Nanotechnology World 2001 meeting. In 2003, he was selected as a recipient of the TR100, which features the worlds 100 Top Young Innovators as selected by Technology Review, the Massachusetts Institute of Technology's Magazine of Innovation. In 2004, he was presented with a NASA Group Achievement Award for his work on harsh environment MEMS. In 2005, he was named as a Whos Who in Biotechnology by Crains Cleveland Business. In 2005 and 2007, he was recognized as a Cleveland Clinic Innovator. In 2009, he was nominated for the Biotechnology Industry Organization's Biotech Humanitarian Award, which is given in recognition of an individual who has used biotechnology to unlock its potential to improve the earth.



**Liviu Klein** was born in Brasov, Romania. He received the B.S. degree in mathematics and computer programming from the Grigore Moisil National IT College, Brasov, Romania, in 1992, the M.D. degree from Carol Davila School of Medicine, Bucharest, Romania, in 1998, and the M.S. degree in clinical investigation from Northwestern University, Chicago, IL, USA, in 2005.

He trained in cardiovascular disease, cardiovascular epidemiology, cardiac electrophysiology, and advanced heart failure and transplantation at Northwestern University and joined the faculty there in 2009. He was the Director of the Heart Failure Device program and established a remote heart failure device clinic, contributing to a successful increase in device utilization and a decrease in heart failure and arrhythmia readmissions. In 2011, he was recruited to the University of California San Francisco (UCSF) to direct the Mechanical Circulatory Support and Heart Failure Device Program. His current research interests include development of sensors and devices for remote monitoring and management of patients with cardiovascular diseases.

Dr. Klein is a Member of the American Heart Association, Heart Failure Society of America and International Society for Lung and Heart Transplant. At UCSF, he is an Assistant Professor of medicine. He has more than 60 publications and book chapters, has received several research awards and has received funding for his research from several device companies, as well as the American Heart Association and National Institutes of Health.



**Omer T. Inan** (S'06–M'09) received the B.S., M.S., and Ph.D. degrees in electrical engineering from Stanford University, Stanford, CA, USA, in 2004, 2005, and 2009, respectively.

He joined ALZA Corporation (A Johnson and Johnson Company) in 2006 as an engineering intern in the Drug Device Research and Development Group, where he designed micropower, high-efficiency circuits for iontophoretic drug delivery, and researched options for closed-loop drug delivery systems. In 2007, he joined Countryman Associates, Inc., Menlo Park, CA where he was a Chief Engineer, involved in designing and developing high-end professional audio circuits and systems. From 2009–2013, he was also a Visiting Scholar in the Department of Electrical Engineering, Stanford University. Since 2013, he has been an Assistant Professor of Electrical and Computer Engineering, and Program Faculty in the Interdisciplinary Bioengineering Graduate Program, at the Georgia Institute of Technology. His research interests include noninvasive physiologic monitoring for human health and performance, and applying novel sensing systems to chronic disease management and pediatric care.

Dr. Inan is an Associate Editor of the *IEEE Journal of Biomedical and Health Informatics*, an Associate Editor for the IEEE Engineering in Medicine and Biology Conference, a Member of the IEEE Technical Committee on Translational Engineering for Healthcare Innovation, and a Technical Program Committee Member or Track Chair for several other major international biomedical engineering conferences. He has published more than 35 technical articles in peer-reviewed international journals and conferences, and has four pending patents. He received the Gerald J. Lieberman Fellowship (Stanford University) in 2008–2009 for outstanding scholarship, teaching, and service. He is a Three-Time National Collegiate Athletic Association All-American in the discus throw, and a former Co-Captain of the Stanford University Track and Field Team.