

Lawrence Berkeley National Laboratory

Recent Work

Title

A Permanent Magnet System for a Cyclotron Used as a Mass Spectrometer

Permalink

<https://escholarship.org/uc/item/2vh2f34q>

Authors

Li, C.Y.

Cooper, M.

Halbach, K.

et al.

Publication Date

1992-07-01

LBL--32037

DE92 040382

A PERMANENT MAGNET SYSTEM FOR A
CYCLOTRON USED AS A MASS SPECTROMETER

C. Y. Li, M. Cooper, K. Halbach, W. B. Kunkel,
K. N. Leung, R. P. Wells, and A. T. Young

July 1992

Lawrence Berkeley Laboratory
University of California
Berkeley, CA 94720

Paper submitted to the 13th International Conference on Cyclotrons and their Applications,
Vancouver, Canada,
July 6-10, 1992.

MASTER

* This work has been supported by the U.S. Department of Energy, Division of Advanced Energy
Projects, Office of Basic Energy Sciences under Contract No. DE-AC03-76SF00098.

DISTRIBUTION OF THIS DOCUMENT IS UNLIMITED

A PERMANENT MAGNET SYSTEM FOR A CYCLOTRON USED AS A MASS SPECTROMETER

C.Y. Li, M. Cooper, K. Halbach, W.B. Kunkel, K.N. Leung, R.P. Wells, and A.T. Young
University of California, Lawrence Berkeley Laboratory
Berkeley, CA 94720 USA

ABSTRACT

The design of a compact, low energy cyclotron used as a mass spectrometer is presented. The instrument is designed for high resolution, high sensitivity detection of trace isotopes. It features the use of permanent magnets to excite the soft iron pole pieces which provide the magnetic field of the cyclotron. Tuning magnets are used to enable the field to be varied. This significantly improves the operational requirements of the instrument when compared to one which uses electromagnets. The cyclotron will use a spiral inflector for axial injection.

1. INTRODUCTION

High sensitivity, high resolution mass spectroscopy has applications in many fields. Among them are archaeology, biomedicine, geology and geochemistry, and environmental research. One method used to achieve these goals is Accelerator Mass Spectroscopy. In this technique, the sample is ionized and accelerated to high energy. Using this technique, detection of trace isotopes at a level of 1 part in 10^{15} has been achieved. In general, most AMS facilities use high energy tandem accelerators with energies in excess of 1 MeV. However, it has been recently demonstrated that high resolution can also be obtained by using a compact, relatively low energy cyclotron as the accelerator.¹⁾ This technique is called Cyclotron Mass Spectrometry (CMS).

At Lawrence Berkeley Laboratory (LBL), a program is underway to develop CMS into an easy to use, inexpensive instrument which is widely available. An overview of this program is given in another paper in these proceedings.²⁾ This paper presents the design of the cyclotron vacuum structure and magnet design.

2. CYCLOTRON DESIGN

2.1 Magnet Design

This cyclotron mass spectrometer has been optimized for the detection of ^{14}C , the isotope of most widespread interest in the AMS community. The magnetic field in the midplane is 1T. For high mass resolution, the orbits need to be isochronous, therefore a flat, uniform field must be maintained throughout the acceleration region. The field in the midplane should be uniform to better than 1 part in 10^4 .

These parameters can be obtained by using permanent magnet material to energize soft iron poles pieces. This is shown schematically in fig 1. Magnet material, such as samarium cobalt, is placed in contact with the iron pole pieces. The iron concentrates and directs the magnetic flux to the pole faces. For one pole, the magnets are oriented so that the B-field vector points toward the pole face. For the other pole piece, the magnets are oriented so that the B-field points away from the pole face. A magnetic flux return ('yoke') connects the magnets to complete the circuit. The midplane of the accelerator is placed between these poles. With careful design, the uniformity of the field will not be set by the magnetic uniformity of the magnet material or where it is placed, but rather by the quality of the finish on the pole faces and the accuracy of the spacing between the poles.

Based on the desired mid-plane B-field, the remnant field of the permanent magnet material, and the geometry of the poles, (i.e. pole diameter and gap width), the amount of permanent magnet material needed is calculated.³⁾ Material

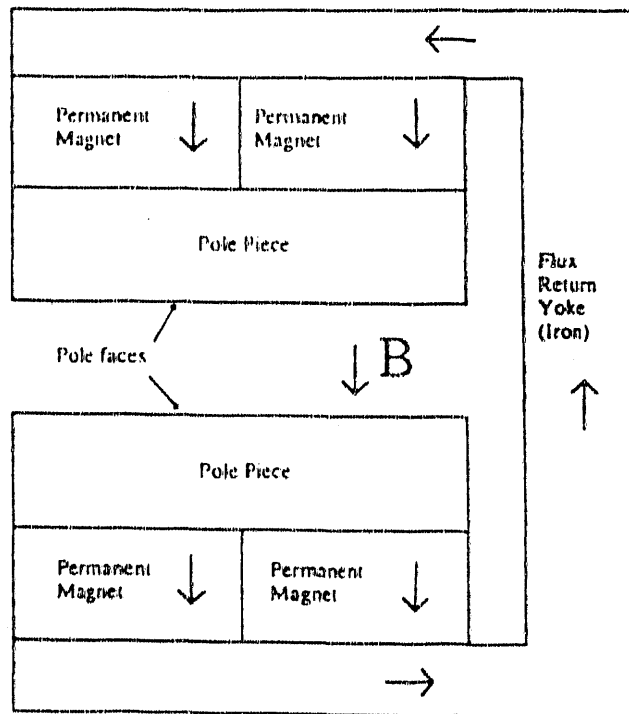

Figure 1 Conceptual design of a permanent magnet excited magnetic field.

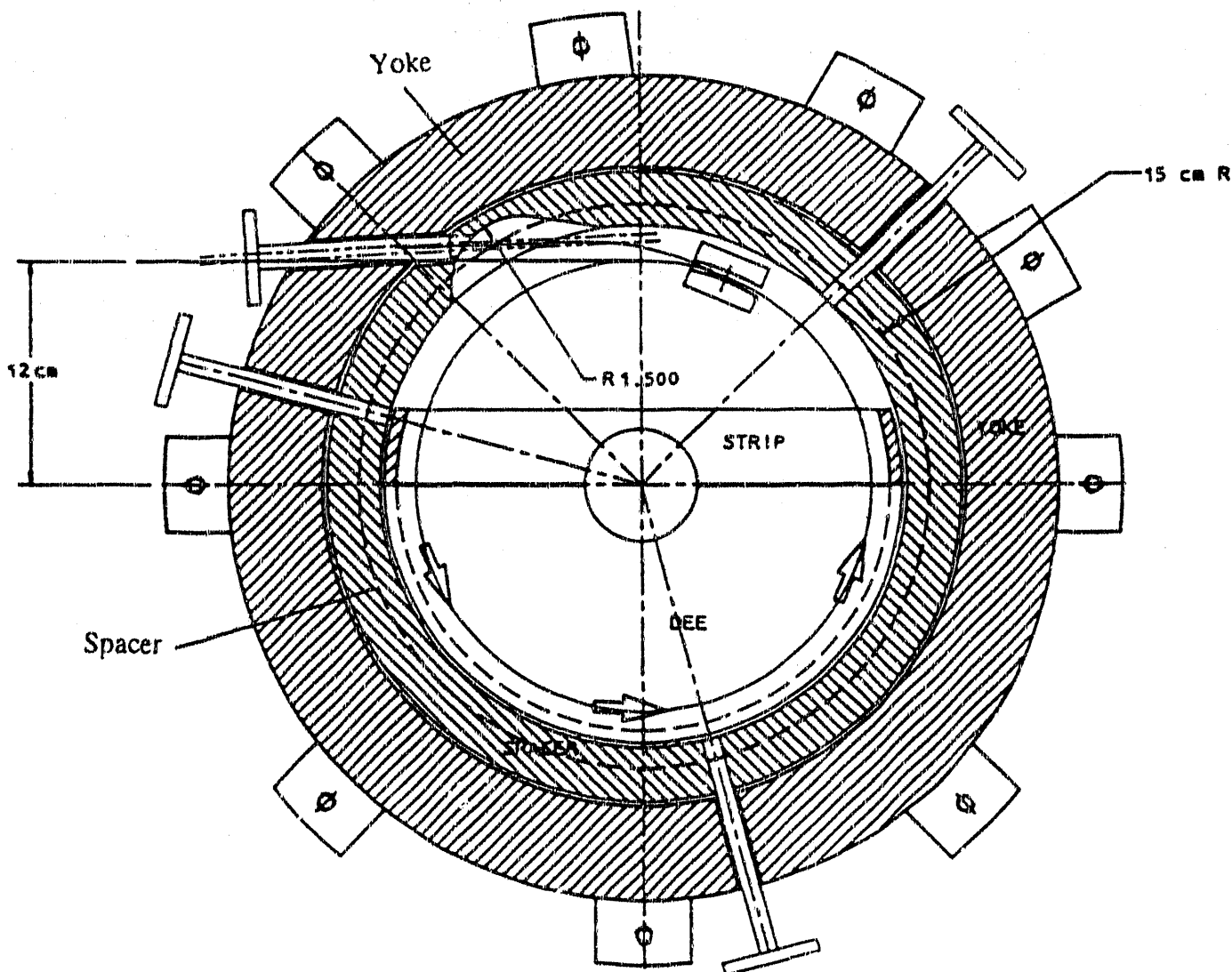

Figure 2 Top View of the Cyclotron Mass Spectrometer (CMS)

can be placed on both the sides of the poles, with the magnetic field vectors pointing radially, and the top and bottom of the poles, with the fields directed axially. Calculation of the magnetic field using the computer program POISSON verified that the field was uniform to better than 1 part in 10^4 throughout the acceleration region.

2.2 Machine Parameters

The overall size of the machine is dictated by the species to be measured, the injection energy of the ion, and the mass resolution needed. For ^{14}C , a mass resolution of about 1800 is needed; this is sufficient to separate ^{14}C from ^{13}CH . The resolution of a CMS is determined by

$$R = 3 \times n \times H \quad (1)$$

where n is the number of orbits the particles make before extraction and H is the harmonic of the fundamental cyclotron frequency that the accelerating RF is operating on. For ^{14}C in a 1T field, the fundamental frequency is 1 MHz. H might typically be 15, so that the minimum number of orbits would be 40. With modest energy gain per turn, ≤ 500 V, it is possible to achieve this figure with an extraction radius of ≤ 9 cm. We have conservatively designed the instrument for an extraction radius of up to 12 cm.

Vacuum requirements are determined by the amount of stripping and scattering of the C^- there is by the residual gas molecules within the accelerator structure. Assuming a stripping cross section on the order of 2×10^{-15} cm², a vacuum level in the mid 10^{-7} torr range will be acceptable.

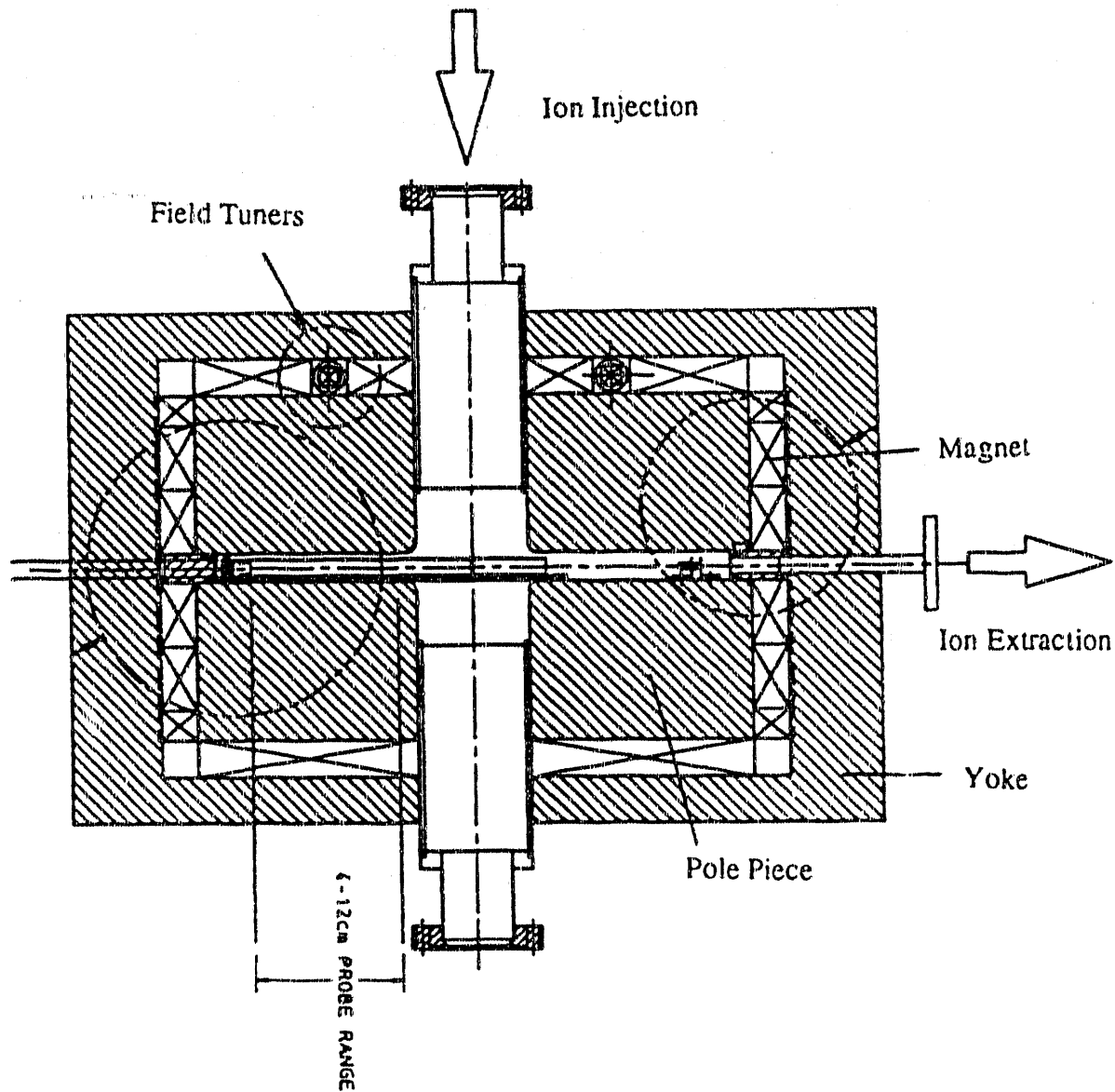

Figure 3 Side view of the CMS

Design parameters for the CMS are summarized in Table 1.

3. DESIGN DETAILS

Figures 2 and 3 show the top and side views of the cyclotron vacuum structure and magnet assembly. The soft iron pole pieces are 15 cm in radius, with an axial hole of about 2.5 cm radius machined into them to provide access for the axial ion injector and pumping ports. The pole pieces are kept apart by an aluminum spacer ring which has an inside diameter of 13.5 cm and a thickness equal to the desired pole gap, 1.6 cm. In this design, the inner pole surfaces are exposed to the high vacuum. This configuration was chosen to reduce the distance between the

pole faces, an important consideration to minimize the magnet material needed to achieve the desired midplane magnetic field. Although the magnet material has good vacuum properties, it has been excluded from the vacuum by o-ring seals in the spacer ring and by welding the beam entrance tube and the vacuum exhaust tube to the pole faces. This minimizes outgassing and virtual leaks.

Accelerated C^+ is extracted using an electrostatic channel and directed out of the cyclotron through a tangential hole in the spacer ring. Additional radial holes in the spacer ring provide access for three 'dee' probes used to measure the ion beam current and position. These probes are mounted on bellows and can move radially from the injection radius to the extraction radius. In addition, they are segmented

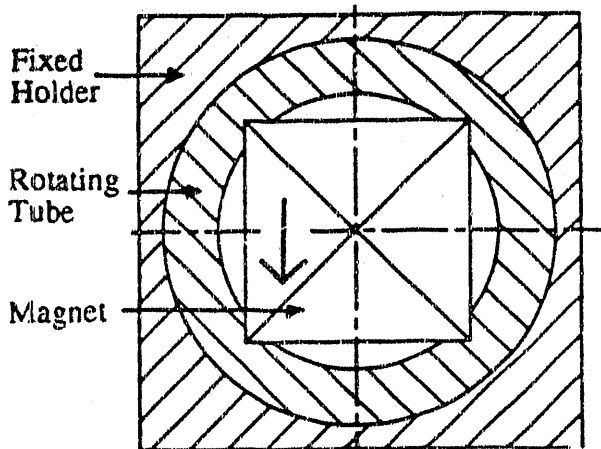

Fig. 4 Cross section of a magnetic field tuner. Arrow is aligned with the magnet's field, which rotates with the rod.

vertically to provide information on the beam properties in that dimension.

The samarium cobalt magnet material is purchased as larger blocks and cut and ground to the desired dimensions. The individual magnets are glued to the flux return yoke for permanent mounting. Approximately 200 individual magnets are used in this design, with a total volume of about 6000 cm³. Magnet material does not completely fill the annular gap between the outer radius of the pole faces and the inner surface of the yoke. This would have required arc-shaped wedges. Instead, the annulus is filled with segments of rectangular magnets. Viewed from the top, the magnets in the annulus appear as an 18-sided polygon with small wedge shaped gaps where the magnet corners on the inner radius touch each other while the outer corners do not. Small ledges are machined in the yoke to aid in the alignment and assembly of these magnets.

Although the top (bottom) of the upper (lower) pole piece also has magnets attached, there are areas on these surfaces where there is no magnet material. This occurs for a variety of reasons, such as for the penetration for the axial injection line. In addition, magnets can be left out to coarsely adjust the magnetic field strength in the midplane. These voids do not affect the field homogeneity as the pole piece 'smooths' out these non-uniformities.

Minor adjustments in the magnetic field will be made by using 'field tuners,' movable magnets which can be oriented such that their magnetic field is parallel, antiparallel, or any angle with respect to the existing field. A cross section of the tuners is shown in fig 4. They consist of rectangular magnets which are placed in tubes. The magnetization vector is radially directed. The tubes are then placed in rectangular holders which will lie across chords in the top and bottom magnet volumes, taking the place of the normal magnets. The rods are free to rotate

Table 1 Design Parameters of the CMS

Pressure	3×10^{-7} torr
Injection Method	Spiral Inflector
Injection Radius	4 cm
Magnet Material	Samarium Cobalt
Pole Radius	15 cm
Pole Gap	1.6 cm
Pole Material	1005 Steel

within the holder, and depending upon the angle between the rod's B-field and the existing field, the tuner may either increase or decrease the midplane field.

4. SUMMARY

The design of a permanent magnet cyclotron has been presented. This instrument has been design for use as a highly sensitive and selective mass spectrometer, optimized for the detection of ¹⁴C. The instrument is now under construction, with completion scheduled by 1993. Initial tests will be conducted with a cesium sputter source, but experiments with an advanced ion source are also planned.⁵⁾

5. ACKNOWLEDGMENTS

This work has been supported by the U.S. Department of Energy, Division of Advanced Energy Projects, Office of Basic Energy Sciences under contract number DE-AC03-76SF00098.

6. REFERENCES

- 1) Bertsche, K.J., Karadi, C.A., Muller, R.A. and Paulson, G.C. Nucl. Instr. and Methods, B52, (1990) 398
- 2) Young, A.T., Bertsche, K.J., Clark, D.J., Halbach, K., Kunkel, W.B., Leung, K.N., and Li, C.Y., these proceedings
- 3) Li, C.Y., Halbach, K. and Young, A.T., in preparation
- 4) Tsuji, H., Ishikawa, J., Maekawa, T., and Takagi, T., Rev. Sci. Instru. 61 (1990) 427
- 5) Leung, K.N., Bachman, D.A., McDonald, D.S., and Young, A.T., these proceedings are references therein