

## **UC Merced**

### **The Journal of California Anthropology**

#### **Title**

The Many Wives of Pedro Yanunali

#### **Permalink**

<https://escholarship.org/uc/item/2qc5k8fq>

#### **Journal**

The Journal of California Anthropology, 4(2)

#### **Author**

Warren, Claude N

#### **Publication Date**

1977-12-01

Peer reviewed

# The Many Wives of Pedro Yanunali

CLAUDE N. WARREN

**T**HIS report presents a method of reconstructing Chumash social organization using Santa Barbara Mission records. The analysis begins with the construction of genealogies based on the mission's baptismal, marriage, and death registers. Using this method, the investigator can reconstruct native marriages and kin relationships which are not directly recorded in the registers. The reconstructed genealogies of four Chumash *capitanes* illustrate this procedure. This study is part of an on-going analysis of mission records from 1787-1806.

Claire Wilson and David Bloom (1969) and Walter Edwards (1969) undertook archival research at the Santa Barbara Mission as a part of their training at the UCLA-UCSB Archaeological Field School in the summer of 1969. Wilson and Bloom analyzed the marriages registered at the Santa Barbara Mission between 1787 and 1806 to determine if the Chumash practiced village exogamy as claimed by Deetz (1969:45-46). They abstracted the following information from each recorded marriage: (1) Male's place of origin; (2) Female's place of origin; (3) Date of marriage; (4) Pagan or non-pagan marriage.

The "pagan" marriages recorded by Wilson and Bloom are those native marriages that were confirmed in the Catholic Church. The Catholic Church would recognize only one spouse; therefore, polygamy is not recorded. The "non-pagan" marriages are those recorded by the Church in which the individuals involved are not recorded as already married.

One of the most difficult problems encountered was the graphic variation in village names as recorded by the priests. Wilson and Bloom enlisted the assistance of Dr. Robert De Souza (Department of Spanish and Portuguese, University of California, Santa Barbara). De Souza isolated 31 classes of village names based on phonetic similarities, although he felt that several pairs of the phonetic classes may represent the same village. This number was further reduced by eliminating any village that occurred less than three times. Wilson and Bloom arrived at a sample of 474 Chumash marriages from 26 villages.

Wilson and Bloom (1969:Appendix E) found that 39% of all marriages were village endogamous, but there was a considerable difference in the percentage of village endogamous marriages between "pagan" and "non-pagan" categories. Wilson and Bloom did not develop this problem further.

I have calculated the Chi-square for the distribution of village endogamy and exogamy in native ("pagan") and Catholic ("non-pagan") marriages as follows:

	Endogamy	Exogamy	
Native	114	68	182
Catholic	72	220	292
	186	288	474
	$\chi^2 = 67.8$		
	df = 1		
	P < .001		

These figures indicate that some factor presumably associated with the Mission in-

creased the percentage of village exogamous Catholic marriages. Therefore, it would appear only native marriages should be considered in attempting to reconstruct the aboriginal Chumash marriage pattern.

Walter Edwards (1969) utilized the Mission Padrón as a source for data in his analysis of residence rules. The Padrón lists the families living at the Mission, giving the name and place of origin for each family member. By noting the birthplace of both parents, Edwards determined village exogamy; and post marital residence was determined from the birthplace of the children. Analysis of 62 couples who had children born between 1790 and 1818, *prior* to their moving to the Mission, provided the following figures (Edwards 1969:4-6):

- 27 endogamous (43.5%)
- 35 exogamous (56.5%)
- 20 matrilocal (32.3%)
- 10 patrilocal (16.1%)
- 3 neolocal (4.9%)
- 2 patri-matrilocal (3.2%)

In the two instances identified as patri-matrilocal, the first child was born in the father's village while subsequent children were born in the village of the mother.

Because the Padrón does not indicate which of the marriages are native ("pagan") and which are Catholic ("non-pagan"), the influences of the Mission on the marriage and residence patterns of these couples remain problematic. I have, therefore, calculated a Chi-square on the distribution of village endogamous and exogamous marriages in the 182 native ("pagan") marriages recorded by Wilson and Bloom and the 62 marriages from the Padrón:

	Endogamy	Exogamy	
Native	114	68	182
Catholic	27	35	62
	141	103	244
	$\chi^2 = 6.9$		
	df = 1		
	P < .02		

The distribution is again non-random, suggesting that the Mission influence increases the number of exogamous marriages in the sample from the Padrón. Therefore, the Mission may also have affected the residence patterns and Edwards' data may be an inaccurate representation of precontact social organization.

In order to develop more accurate data for aboriginal Chumash marriage and residence patterns, the Santa Barbara Mission baptismal, marriage, and burial registers are being used to reconstruct Chumash genealogies. We have found that even though the Catholic Church did not recognize the native marriages, the priests carefully recorded the neophytes' relationships to one another and even to "gentile" relatives. The Mission records also list places of residence, identify *capitanes* or chiefs, give native names, ages, and other data that allow reliable identification of individuals and their relationships. These records allow reconstruction of native marriages that were neither confirmed by the Church nor recorded by the priests. This in turn allows the reconstruction of native genealogies providing data for the occurrence of exogamy and post-marital residence patterns. To date I have not completed the analysis of the Mission records and cannot provide accurate counts of exogamous marriages or residence patterns. However, in the remaining portion of this paper I will present three limited genealogies of the families of village chiefs in order to illustrate (1) how native marriages that are not recorded can be reconstructed, and (2) how these relate to other questions of Chumash social and political organization.

Aliolioliquic, baptized Domingo Joseph, June 26, 1787, was married to Yaximaful, baptized María Ignacia, February 2, 1787, in a Catholic ceremony September 13, 1788. The data from the baptismal records indicate Domingo Joseph had a second native wife although this native marriage is not formally recorded (Fig. 1). This conclusion is drawn

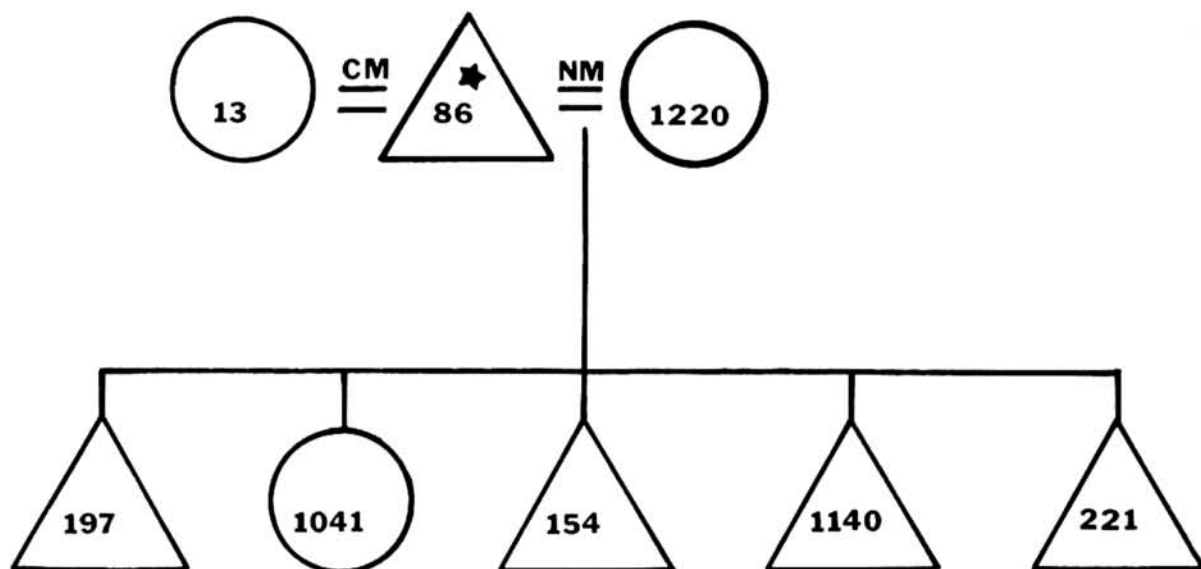

Fig. 1. Family of Domingo Joseph Aliolioliquic illustrating unrecorded native marriages (NM) recorded Catholic marriage (CM) and the children of Domingo Joseph (86) and Paula María (1220). Star indicates *capitán* of village.

from the following data:

1. Baptism #86. June 26, 1787. A man, 41 years of age, called by the native name Aliolioliquic of the village Alcaza. Baptized Domingo Joseph.
2. Baptism #154. August 12, 1787. A man, 12 years of age, called by the native name Tueumequit. Baptized Bonifacio.
3. Baptism #197. January 22, 1788. A boy, 6 or 7 years of age, son of Domingo Aliolioliquic, *capitán* of the village of Alcas. Baptized Baltasar María.
4. Baptism #221. March 22, 1788. A man, 22 years of age, called by the native name Cunauyacet, son of Domingo Joseph of Alcas. Baptized Elías Joseph.
5. Baptism #1041. February 9, 1797. A woman, 18 years of age, native of the village of Alcajch, sister of Elías who is husband of Albina Josefa, of Bonifacio who is married to María del Pilar, and of Baltasar. Baptized Florentina María.
6. Baptism #1140. September 11, 1797. A

man called Teminaut, 23 years of age, and a native of the village Alcajch. Brother of Elías, Bonifacio, Baltasar, and of Florentina María. Baptized Leandro.

7. Baptism #1220. January 25, 1798. Baptized privately *in casu necessitatis*. A woman, 60 years of age, native of the village of Alcajch. Mother of Elías, Bonifacio, Leandro, Baltasar, and Florentina. Baptized Paula María.

Paula María, Domingo Joseph's native wife, was baptized on her death bed. Domingo Joseph's marriage to Paula María was not recognized or recorded in the Mission records, but is assumed because she is the mother of Domingo Joseph's children. Domingo Joseph was married to María Ignacia nine years before Paula María died. This suggests that Domingo Joseph had two wives, a practice reported for Chumash *capitanes*.

The family diagram (Fig. 2) of Francisco Yuyunatset provides a second example of a native marriage not recorded by the Mission in

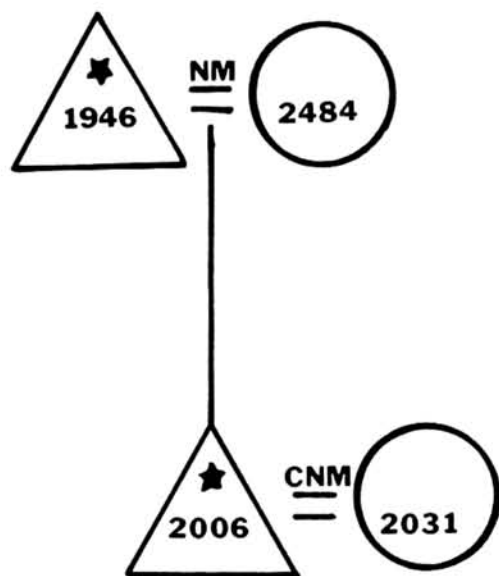

Fig. 2. Family of Francisco Yuyunatset illustrating unrecorded native marriage (NM) and native marriage confirmed by the Catholic Church (CNM). Star indicates *capitán* of village.

addition to a native marriage confirmed in the Catholic Church. The diagram also suggests that the "chieftainship" is passed through the male line. The data, abstracted from the baptismal, marriage, and burial records are as follows:

1. Baptism #1946. September 11, 1802. A man, gravely ill, called Yuyunatset, *capitán* and native of Saspili. Baptized Francisco.
2. Death of Francisco Yuyunatset is noted on the same day between burial record #892 and #893.
3. Baptism #2006. January 27, 1803. A man, *in articulo mortis*, 24 years of age called Saoicayaut and native of Saspili of which he is *capitán*. Son of deceased Francisco Yuyunatset. Baptized Juan Chrysóstomo. [Juan Chrysóstomo did not die.]
4. Baptism #2031. March 17, 1803. A woman, 24 years of age, native of

Saspili, native wife of Juan Chrysóstomo Saoicayaut, *capitán* of Saspili. Baptized Fabiana. [Note that Fabiana is *native wife* of Juan Chrysóstomo on this date.]

5. Marriage #451. April 4, 1803. Fabiana, native of the village of Saspili, married Juan Chrysóstomo Saijcauyaut, *capitán* and native of Saspili.
6. Baptism #2484. May 31, 1803. A woman, 52 years of age, of Saspili, mother of Juan Chrysóstomo, *capitán* of Saspili. Baptized Apolinaria.

Francisco Yuyunatset's marriage to Apolinaria was not recognized or recorded by the Church. It is assumed because Apolinaria is the mother of Francisco's son Juan Chrysóstomo. Juan Chrysóstomo's marriage to Fabiana is not recorded as a native marriage in the record of the Church marriage, but is noted in Fabiana's baptismal record some 18 days before the Catholic marriage took place.

One of the more colorful and important Chumash *capitanes* to appear in the history of Santa Barbara as well as in the Mission records is Pedro Yanunali, *capitán* of Siujtu. His importance was noted by the Spanish and it was said that he had authority over 13 towns (King 1969:41). Pedro Yanunali was 60 years old when he was baptized. He already had lived a long life, one of prestige and power. He is the kind of *capitán* we would expect to have many wives. His family relationships (Fig. 3) are more complex than the others I have illustrated.

The data abstracted from the mission records used in reconstructing Yanunali's relationships are as follows:

1. Baptism #1123. September 11, 1797. A man called Tatauit, 35 years of age, native of the village of Siujtu and son of Pedro Yanunali, *capitán* of the same village. Baptized Matheo.
2. Baptism #1147. September 12, 1797. A man, 60 years of age, called Yanunali,

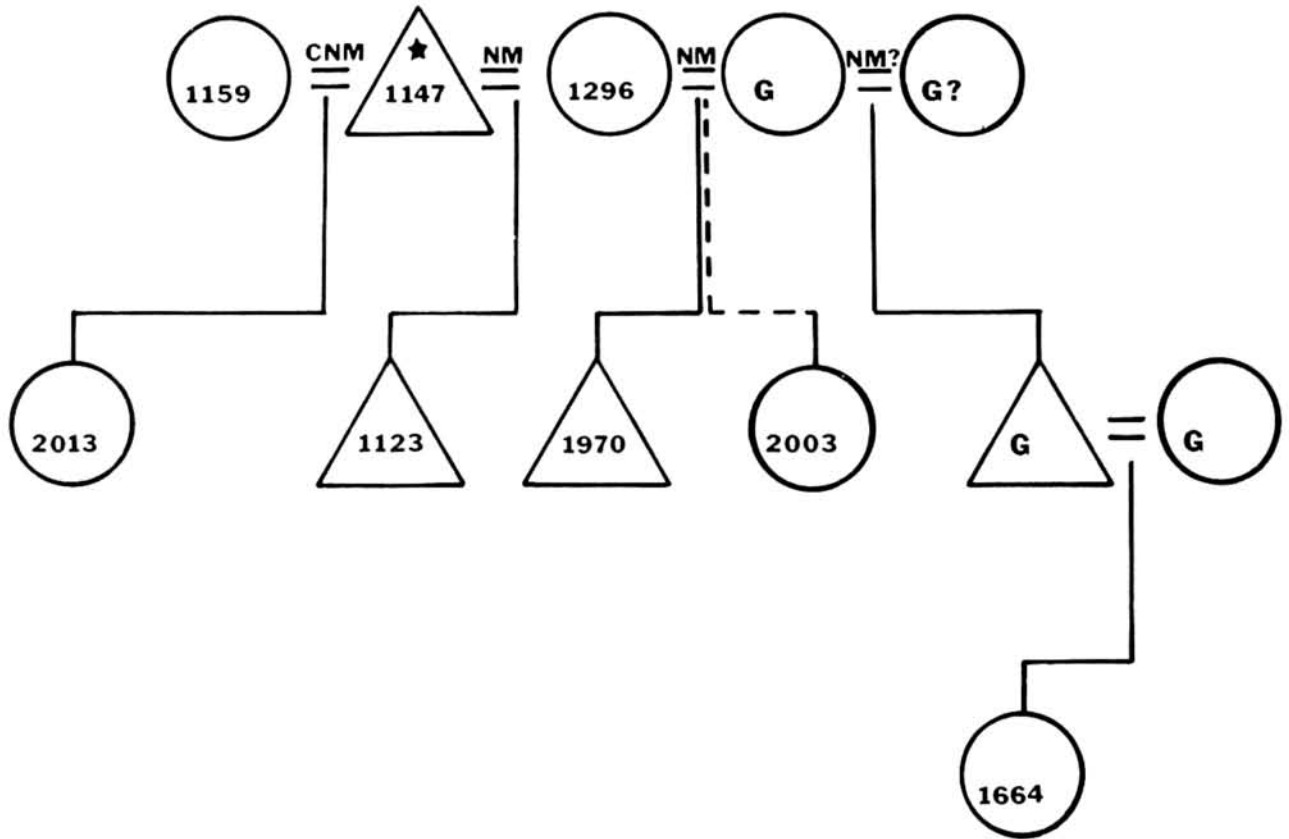

Fig. 3. Pedro Yanunali's family with native marriage confirmed by the Catholic Church (CNM) and native marriages (NM) not recorded by the Church. "G" indicates "gentile." "G?" indicates postulated fourth wife. Star indicates *capitán* of village.

- capitán* of the village of Siujtu and a native of that village. Father of Matheo Tatuit. Baptized Pedro.
- Baptism #1159. September 12, 1797. A woman, 45 years of age, native of Siujtu, sister of José Manuel married to Carolina. Baptized Anastasia.
  - Marriage #263. September 12, 1797. Pedro Yanunali to Anastasia. Native marriage confirmed by the Church.
  - Baptism #1296. November 22, 1798. A woman, gravely ill, 68 years of age, mother of Matheo married to Margarita. Baptized Cecilia.
  - Burial #488. November 25, 1798. Died in the village of Siujtu. A woman named Cecilia, native of that village

- and mother of Matheo married to Margarita.
- Baptism #1664. May 3, 1801. A baby girl, one month old, daughter of pagan parents of the village of Huisapa. Her father is named Liguicuhait and is the son of Pedro Yanunali, *capitán* of Siujtu. Baptized Pía María.
  - Baptism #1970. October 23, 1802. A boy, 12 years of age, called Cami, native of Cajatsa on the islands. Son of Pedro Yanunali and a gentile mother. Baptized Pedro Celestino.
  - Baptism #2003. January 22, 1803. A woman, 20 years of age, native of the village Cajatsa, daughter of Pedro Yanunali married to Anastasia. Bap-

tized Margarita de Consona. [Note this does not mean that Margarita de Consona is the daughter of Anastasia.]

10. Baptism #2013. February 14, 1803. A woman, 23 years of age, daughter of Pedro Yanunali and of Anastasia. Baptized Antonia María.

Pedro Yanunali's marriage to Anastasia was a native marriage confirmed by the Church. Cecilia is assumed to have been his native wife because she is the mother of his son Mateo. His son Pedro Celestino is the son of a "gentile" woman we assume to be his third wife. His daughter Margarita de Consona is apparently not Anastasia's daughter and may have the same mother as Pedro Celestino since they are natives of Cajatsa, a village on one of the islands. Pedro Yanunali's "gentile" son, Liguicuhuit, is listed as a native of the village Huisapa, located in the Santa Inez Valley. If this is correct it seems likely that Pedro Yanunali had yet another "gentile" wife in the hinterland. By 1800 Pedro Yanunali had children ranging in age from 10 to 38 and had at least one wife in Cajatsa on the island, two at Siujtu and perhaps another at Huisapa in the Santa Inez Valley.

The many wives of Yanunali are but one example of the uses of genealogical material in reconstructing socio-political data on the Chumash. The sequence of his children's births even permits a rough tracing of his geographical movements. Yanunali had children born to his Siujtu wives in 1762 and 1780, to his Cajatsa wife(s) in 1783 and 1790. In addition, sometime between 1762 and 1785 his son Liguicuhuit of Huisapa was born to a presumed third wife. Yanunali's network of kin may explain why the Spanish identified him as a man of such power.

The question arises as to whether or not Pedro Yanunali was recognized as a *capitán* in Cajatsa and other villages. The Mission records are clear in the fact some men were *capitanes* in villages that were not their "native

villages." Pedro Lihusanaitset was *capitán* at Siujtu in 1803, but his native village was Esniquil and his five-year-old daughter is listed as a native of Siujtu (baptism #2042, marriage #863). Felipe Antonio Ajuyaut (baptism #2414) is listed as a native of Siujtu, but a *capitán* in Saspili. Brown (1967:48) makes reference to the son of the "Old Chief" of Siujtu, who was chief of Najalayegua. This taken together with the fact that in 1803 Siujtu had at least two *capitanes* (Pedro Yanunali and Pablo Lihusanaitset), Saspili four (Juan Chrysóstimo Saoicayant, Mariano Matihuluit, Juan Siccuyahuit and Felipe Antonio Ajuyant), Gelo two (Efrén Chuicme and Fermín Chichimahuit), and Cuyamu two (Bonifacio Suapnunatset and Beato Temiacucat) strongly suggest that the office of *capitán* referred to a clan or moiety rather than the village.

As analysis and genealogical reconstruction continues, we hope to unearth further detailed material on the socio-political organization of the Chumash. The data presented above result from analysis of only a portion of the mission records. With further work, the quantity of data relevant to Chumash socio-political organization should increase significantly.

#### ACKNOWLEDGEMENTS

The list of students who have worked abstracting Mission records and reconstructing genealogies now numbers in the dozens, and space does not allow me to name them all. There are some, however, who deserve special mention. Claire Wilson, David Bloom, Walter Edwards, and Jan Peterson from the 1969 UCLA-UCSB Archaeological Field School; Robert Lopez and Bernard Sarofman from the UNLV-UCLA Field School in Education and Archaeology of 1971; Gary Coombs who participated in both the 1969 and 1971 field schools. All of these students stimulated my interest and challenged

my intellectual abilities by their papers and discussions and have been a major influence on my interest in and work with the Mission records.

During the 1971 field school every student spent some time in the Santa Barbara Mission Archives abstracting data from the baptismal and marriage records. This resulted in a great quantity of well organized data that could not have been obtained without the financial aid provided by the National Endowment for the Humanities Grant Number EO-4587-71-24.

I wish to acknowledge the late Father Maynard Geiger, O.F.M., Archivist for Santa Barbara Mission, for his unceasing assistance and cooperation.

Drs. George Urioste, Gary Palmer, and John Swetnam provided constructive comments and assistance in translating difficult passages. And finally, Judith Burk and Joyce Lee typed the many drafts of this short paper.

*University of Nevada, Las Vegas*

#### REFERENCES

- Brown, Alan K.  
1967 The Aboriginal Population of the Santa Barbara Channel. Berkeley: University of California Archaeological Survey Reports No. 69.
- Deetz, James  
1969 The Inference of Residence and Descent Rules from Archaeological Data. *In* *New Perspectives in Archaeology*, Sally R. Binford and Lewis P. Binford, eds., pp. 41-48. Chicago: Aldine Publishing Company.
- Edwards, Walter  
1969 An Ethnohistorical Approach to the Study of Chumash Social Structure. Manuscript on file at the Department of Anthropology, University of Nevada, Las Vegas.
- King, Linda  
1969 The Medea Creek Cemetery (LAn-243): An Investigation of Social Organization from Mortuary Practices. Los Angeles: University of California Archaeological Survey Annual Report 11:23-68.
- Wilson, Claire, and David Bloom  
1969 Chumash Marriage Patterns. Manuscript on file at the Department of Anthropology, University of Nevada, Las Vegas.

