

# Lawrence Berkeley National Laboratory

## Recent Work

### Title

Design and Test of a Model Pole for the ALS U5.0 Undulator

### Permalink

<https://escholarship.org/uc/item/2pt3553d>

### Authors

Hassenzahl, W.V.

Hoyer, E.

Savoy, R.

### Publication Date

1991-05-01



# Lawrence Berkeley Laboratory

UNIVERSITY OF CALIFORNIA

## Accelerator & Fusion Research Division

Presented at the IEEE Particle Accelerator Conference,  
San Francisco, CA, May 6-9, 1991, and to be  
published in the Proceedings

### Design and Test of a Model Pole for the ALS U5.0 Undulator

W.V. Hassenzahl, E. Hoyer, and R. Savoy

May 1991

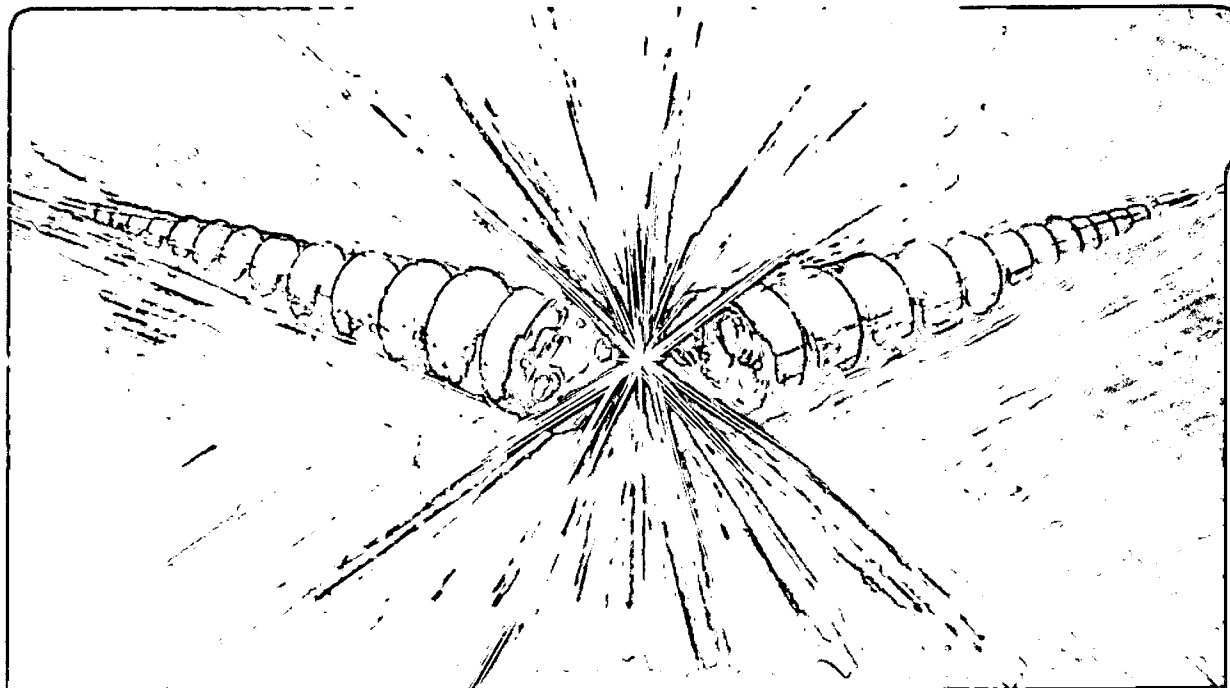

1 LOAN COPY 1  
1 Circulates 1  
1 for 4 weeks 1

Bldg. 50 Library.  
Copy 2

LBL-29921

## **DISCLAIMER**

This document was prepared as an account of work sponsored by the United States Government. While this document is believed to contain correct information, neither the United States Government nor any agency thereof, nor the Regents of the University of California, nor any of their employees, makes any warranty, express or implied, or assumes any legal responsibility for the accuracy, completeness, or usefulness of any information, apparatus, product, or process disclosed, or represents that its use would not infringe privately owned rights. Reference herein to any specific commercial product, process, or service by its trade name, trademark, manufacturer, or otherwise, does not necessarily constitute or imply its endorsement, recommendation, or favoring by the United States Government or any agency thereof, or the Regents of the University of California. The views and opinions of authors expressed herein do not necessarily state or reflect those of the United States Government or any agency thereof or the Regents of the University of California.

**DESIGN AND TEST OF A MODEL POLE FOR THE ALS U5.0  
UNDULATOR\***

W.V. Hassenzahl and E. Hoyer

Accelerator and Fusion Research Division  
Lawrence Berkeley Laboratory  
University of California  
Berkeley, CA 94720

R. Savoy

Argonne National Laboratory  
Argonne, IL 60439-4814

May 1991

Paper presented to the IEEE Particle Accelerator Conference, San Francisco, CA, May 6-9, 1991

This report has been reproduced directly from the best available copy.

\*This work was supported by the Director, Office of Energy Research, Office of Basic Energy Sciences, Materials Sciences Division of the U.S. Department of Energy, under Contract No. DE-AC03-76SF00098

# DESIGN AND TEST OF A MODEL POLE FOR THE ALS U5.0 UNDULATOR

W. V. Hassenzahl and E. Hoyer

Accelerator and Fusion Research Division, Lawrence Berkeley Laboratory,  
University of California, Berkeley, California 94720

R. Savoy

Argonne National Laboratory, Argonne, Illinois 60439-4814

## Abstract

The ALS insertion devices must meet very tight requirements in terms of field quality and field strength. Even though the ability to calculate the performance of a hybrid insertion device has improved considerably over the past few years, a model pole was assembled to test the ALS U5.0 undulator geometry and to verify the calculations. The model pole consists of a half period of the periodic structure of the insertion device, with mirror plates at the midplane and at the zero-field, half-period planes. A Hall probe was used to measure the vertical component of the field near the midplane of the model as a function of gap and transverse position. Field quality requirements demand that the ALS insertion devices be designed to permit several types of correction, including the capability of adding magnetic material or iron at several locations to boost or buck the field. This correction capability was evaluated during our tests. The model is described and the test results are discussed, including the fact that the measured peak field is several percent higher than the calculated value, which is based on the measured magnetization of the blocks used in the model.

## I. INTRODUCTION

Insertion devices for the Lawrence Berkeley Laboratory (LBL) Advanced Light Source (ALS) and other third generation synchrotron light sources must meet more stringent tolerance requirements than insertion devices built to date for existing light sources. Considerable effort has been dedicated to the development of requirements for the U5.0, a 5 cm period undulator,<sup>1</sup> the first insertion device for the ALS. The preferred design choice for high performance devices is a hybrid configuration with vanadium permendur poles and neodymium-iron-boron (Nd-Fe-B) permanent magnets. The performance of a device is determined by the peak field at minimum gap and the magnetic field errors. The peak field as a function of gap can be calculated with a three dimensional theory of hybrid devices<sup>2</sup>. An extension of this theory<sup>3</sup> was used to estimate the field errors due to various material and assembly tolerances in the U5.0. To ensure peak field performance of the U5.0 undulator, a half-period model of the magnetic structure was constructed and tested to determine the peak field at the midplane and the transverse variation of the vertical field for the nominal design. This paper addresses the peak field characteristics.

## II. DESCRIPTION OF THE U5.0 MODEL POLE ASSEMBLY

The U5.0 model pole assembly shown in Fig. 1 consists of: 1. a vanadium permendur pole; 2. eight Nd-Fe-B blocks that are 0.85 cm thick (half the thickness of the U5.0 blocks); 3. a keeper that holds the pole and blocks in place and allows iron and permanent magnet material, sometimes called Current (or Charge) Sheet Equivalent Material (CSEM) inserts or studs to be placed close to the pole; 4. a set of three mirror plates that define the magnetic symmetry of the device (one is at the midplane and one at each of the 1/4 period planes); and 5. a mounting fixture, which simulates the backing beam-including the side pieces. This fixture allows the pole to be positioned at distances above the midplane corresponding to various half gaps. The pole and the eight CSEM blocks form half of a U5.0 half period, the smallest unit of the periodic magnetic structure that can be modeled.

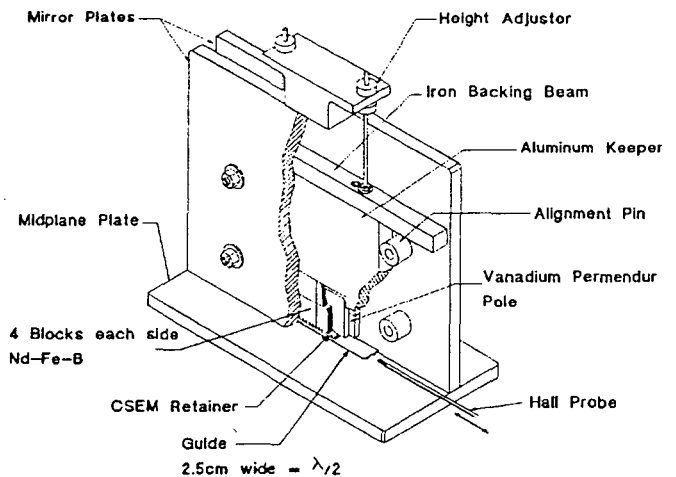

Figure 1. Cutaway View of the U5.0 Model Pole Showing the Major Components.

To study magnetic field tuning the aluminum pole keeper was constructed with three tapped holes on each side to hold iron or CSEM inserts. The inserts were all 5.6 mm (0.220") in diameter and were held in threaded brass rods that accurately position them close to the pole. Both types of inserts were made in lengths of 11.2 and 20.6 mm.

### III. THE GAP DEPENDENCE OF THE MAGNETIC FIELD

The peak field was measured at several gaps. This field is the algebraic sum of all the spatial field harmonics.

$$B_p = \sum_{i=1}^{\infty} B_{2i+1}$$

The quantity of interest, however, is the effective field,  $B_{\text{eff}}$  which enters into the calculation of the spectrum of the light emitted by the undulator.  $B_{\text{eff}}$  is given by

$$B_{\text{eff}} = \left\{ \sum_{i=1}^{\infty} [B_{2i+1}/(2i+1)]^2 \right\}^{1/2}$$

The relationship between the peak field and the effective field depends on the geometry of the device and can be found from the spatial field distribution, i.e. the magnitude of the spatial field harmonics. The gap dependence of each spatial harmonic of the field is given by

$$B_{2i+1}(g_1) = B_{2i+1}(g_2) \exp(2\pi(2i+1)\{g_2 - g_1\}/\lambda_u)$$

The spatial field distribution can be calculated accurately by POISSON using the geometry and measured permeability of the pole. The theory of hybrid insertion devices, developed by K. Halbach,<sup>3</sup> can then be combined with these POISSON results to predict the peak field. The measured and calculated gap dependence of the peak field is given in Fig. 2.

The calculated fields are slightly smaller than the measured values. This difference varies from about 3% for the smallest gap to 10% for the largest gap. The source of this discrepancy is not understood at this time. Fortunately, the measured fields are larger. At a 7.0 mm half gap the measured peak field is 1.03 T, which yields an effective field of about 0.96T, which is well above the design goal of 0.88 T.

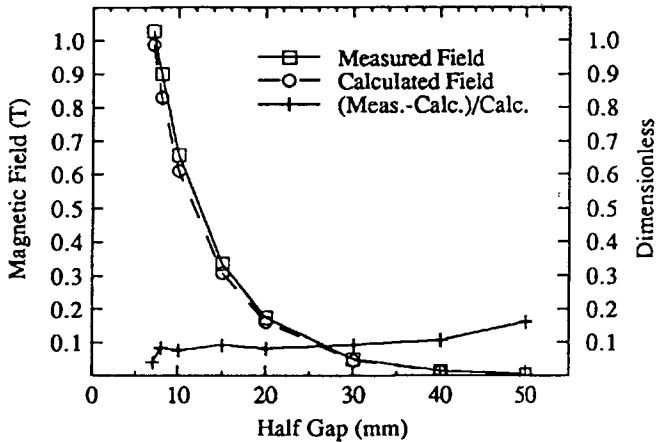

Figure 2. Measured and Calculated Peak Field as a Function of Half Gap.

### IV. MAGNETIC FIELD VARIATION IN THE X DIRECTION

Transverse (x) profiles of  $B_y$  were obtained by scanning the Hall probe from the field-free region on one side of the pole,  $x \approx +100$  mm, to an equivalent position on the other side,  $x \approx -100$  mm. The field was measured with a Hall probe at discrete transverse locations (usually every 2 mm). Figure 3 shows the normalized magnetic field near the center of the device for half gaps of 7, 10, 15 and 20 mm.

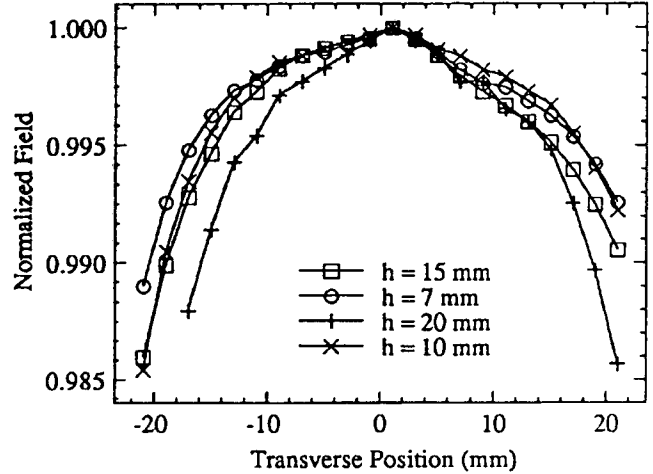

Figure 3. Transverse Profile of the Field for Different Half Gaps.

### V. FIELD MODIFICATIONS DUE TO SHIMMING?

A major concern in the design of an insertion device is that the magnitude and/or distribution of the error fields exceeds the specifications. The underlying philosophy in ALS insertion device design is to limit errors by assigning tight tolerances. But, as a fall back position, the ALS insertion device design includes several methods of local field correction. We used the U5.0 model pole assembly to evaluate two methods of adjusting the field; either CSEM or iron studs were placed on the sides of the pole. Because of the model geometry, the effect of any pole modification is the same as if all poles had received the same change in scalar potential.

The CSEM inserts were magnetized along the length (or axis) of the cylinder, and could be oriented to either boost or reduce the central magnetic field.

Two typical difference maps, with one and two CSEM studs in the bottom position, are shown in Fig. 4. The pair of studs boosted the field under the pole by about 0.35%. The large field excursions near  $\pm 60$  mm are caused by flux that goes directly from the "magnetic charge" at the end of the stud to the midplane, which is a graphic example of the direct field<sup>3</sup>. The field in the center of the device is boosted twice as much for two studs as it is for one, which suggests that saturation does not degrade the effect of the inserts.

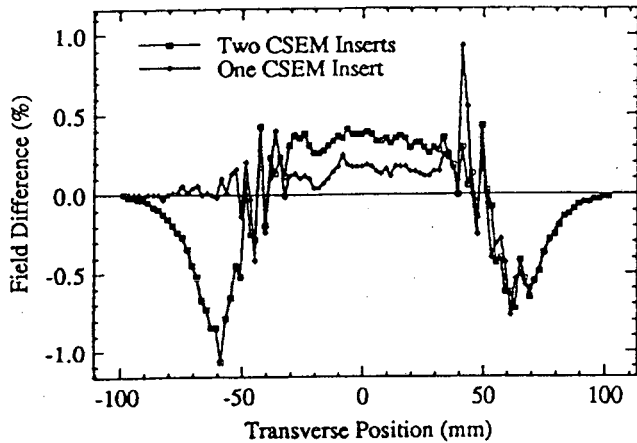

Figure 4. Field Change due to CSEM Inserts

The change of center field as a function of the CSEM distance from the pole is plotted in Fig. 5. One turn of the screw that captures the CSEM insert increases the distance from the pole by 1.81 mm. The figure shows that 50% of the effect occurs within the first two turns of the screw. The effect on the central field of the long CSEM stud pairs in the bottom and middle positions was studied as a function of gap. The results of these measurements are shown in Fig. 6.

Except for small gaps, the field produced by the inserts tracks that produced by the main CSEM. Our suspicion is that the differences are caused by saturation effects in the pole. There is a significant variation in the normalized change of the central field and the field difference from a 0.7 cm gap to a 1.0 cm gap.

The effect on the transverse field distribution of an iron stud on one side is given in Fig. 7. The large peak at -50 mm is caused by the direct fields of the stud. The field change under the pole exhibits a gradient, showing that there is a potential drop along the pole, which is a sign of pole saturation.

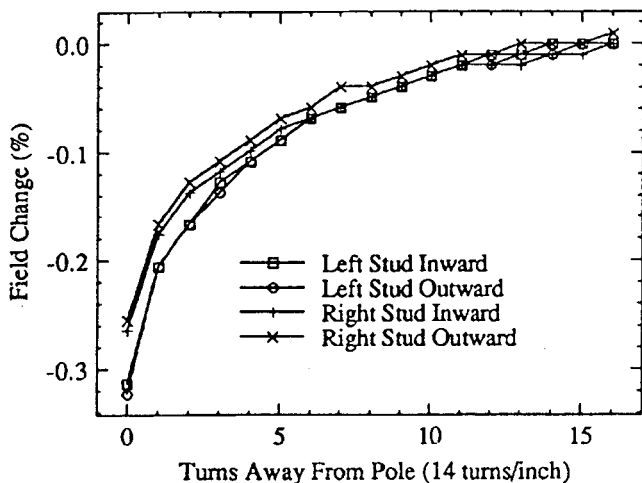

Figure 5. Variation of Central Field as a Function of Insert Location

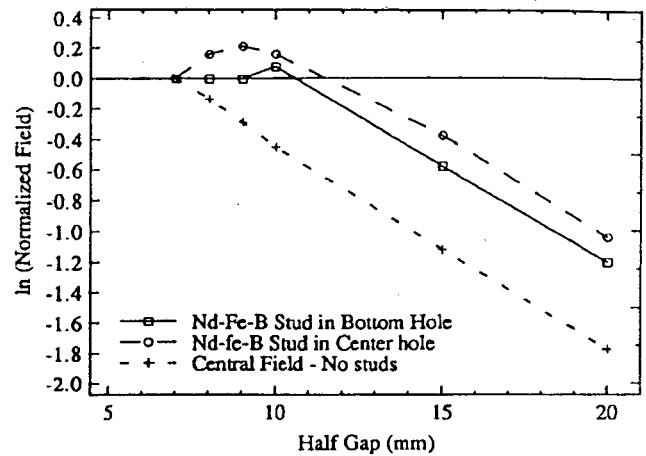

Figure 6. Half Gap Dependence of Field and Field Variation Due to CSEM Inserts.

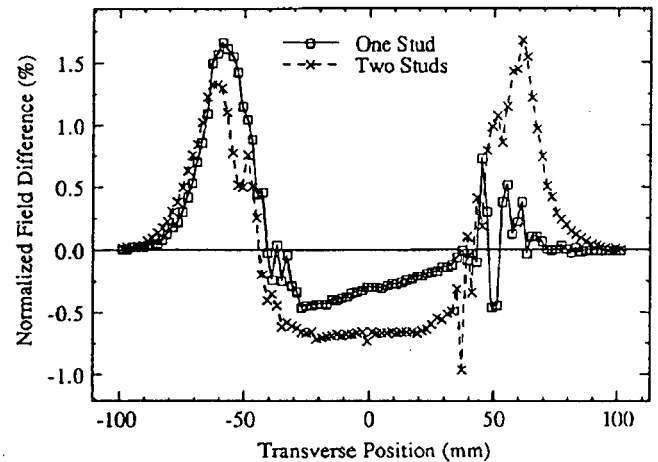

Figure 7. Transverse Scan Showing the Effect of Iron Inserts.

The effect of a pair of studs has no gradient, as shown in Fig. 7. We observe no measurable direct fields in the midplane for the studs in the higher positions.

## VI. ACKNOWLEDGMENT

\*This work was supported by the Director, Office of Energy Research, Office of Basic Energy Sciences, Materials Sciences Division of the U.S. Department of Energy, under Contract No. DE-AC03-76SF00098

## VII. REFERENCES

1. "U5.0 Conceptual Design Report" LBL Report PUB-5256, November, 1989.
2. K. Halbach, "Design of Magnets" videotape lecture series Jülich, Germany, May-June, 1985.
3. K. Halbach, "Design of Hybrid Insertion Devices", videotape lecture series, LBL Report V-8811, October, 1988 - March, 1989.
4. R. Savoy, personal notes.

LAWRENCE BERKELEY LABORATORY  
UNIVERSITY OF CALIFORNIA  
INFORMATION RESOURCES DEPARTMENT  
BERKELEY, CALIFORNIA 94720