

# Lawrence Berkeley National Laboratory

## LBL Publications

### Title

Heavy Ion Development at the Berkeley 88-Inch Cyclotron

### Permalink

<https://escholarship.org/uc/item/2nv2s1vc>

### Authors

Clark, D J  
Steyaert, J  
Carneiro, A  
et al.

### Publication Date

1971-11-01

### Copyright Information

This work is made available under the terms of a Creative Commons Attribution License, available at <https://creativecommons.org/licenses/by/4.0/>

Presented at the International Conference  
on Multiply-Charged Heavy Ion Sources  
and Accelerating System  
Gatlinburg, Tennessee, October 25-28, 1971

LBL-223  
Preprint

C.2

HEAVY ION DEVELOPMENT AT THE  
BERKELEY 88-INCH CYCLOTRON

D. J. Clark, J. Steyaert, A. Carneiro and D. Morris

November 1971

AEC Contract No. W-7405-eng-48

RECEIVED  
LIBRARY  
OCT 21 1971

FORWARDED TO



**TWO-WEEK LOAN COPY**

This is a Library Circulating Copy  
which may be borrowed for two weeks.  
For a personal retention copy, call  
Tech. Info. Division, Ext. 5545

LBL-223  
C.2

28

## **DISCLAIMER**

This document was prepared as an account of work sponsored by the United States Government. While this document is believed to contain correct information, neither the United States Government nor any agency thereof, nor the Regents of the University of California, nor any of their employees, makes any warranty, express or implied, or assumes any legal responsibility for the accuracy, completeness, or usefulness of any information, apparatus, product, or process disclosed, or represents that its use would not infringe privately owned rights. Reference herein to any specific commercial product, process, or service by its trade name, trademark, manufacturer, or otherwise, does not necessarily constitute or imply its endorsement, recommendation, or favoring by the United States Government or any agency thereof, or the Regents of the University of California. The views and opinions of authors expressed herein do not necessarily state or reflect those of the United States Government or any agency thereof or the Regents of the University of California.

HEAVY ION DEVELOPMENT AT THE BERKELEY 88-INCH CYCLOTRON\*

D.J. Clark, J. Steyaert<sup>†</sup>, A. Carneiro, and D. Morris

Lawrence Berkeley Laboratory  
University of California  
Berkeley, California 94720

November 1971

SUMMARY

A new internal Penning ion source is now being tested for production of nitrogen and oxygen beams. Nitrogen beams of  $N^{5+}$  have been accelerated to 250 MeV. An external source for lithium beams is being developed.

## INTRODUCTION

Interest in heavy ion experiments has been increasing during the past year at the 88-Inch Cyclotron. The beams required are lithium, carbon, nitrogen, and oxygen in the 50-80 MeV region for studies of nuclear structure and reaction mechanisms. Also nitrogen beams of the highest available energy are used for bio-medical studies of radiation damage. The original internal ion source<sup>1</sup> has been used to produce these beams, but has limited arc power and filament life. To get more arc power, a Penning Ion Gauge or "PIG" type source was built, and is now being tested. The external PIG source reported in March 1971<sup>2</sup> is being developed for lithium beam production by the addition of an oven.

### OPERATION WITH HEAVY IONS

The 88-Inch Cyclotron can accelerate ions heavier than  $\alpha$ -particles to an energy of  $E = 140 Q^2/A$  MeV, where  $Q$  and  $A$  are ion charge and mass in proton units. The cyclotron setting of center region, trim coils and deflector for heavy ions are based upon the best operating beams of light ions. Center region source and puller positions are set to be the same as a light ion beam having the same number of revolutions during acceleration. The computer code CYDE is used to calculate a set of trim coil currents which give the same magnetic field center bump and edge fall-off as a light particle beam having the same number of revolutions. If no reference light particle beam exists, or if a new third or fifth harmonic beam is required, we start from the best estimated settings and optimize them with beam on the cyclotron. The deflector position settings are obtained from a light ion beam, scaling the deflector voltage proportional to energy/charge of the ion.

A useful technique for obtaining a difficult beam such as 250 MeV  $N^{5+}$  is to start with an easier one at the same magnetic field, 160 MeV  $N^{4+}$ . Then the dee voltage is increased proportional to energy/charge to give the same number of turns and centering conditions. The deflector voltage is increased by the same factor. The frequency is increased the proper amount. The trim coils are changed to give isochronism, but using the same center bump and edge fall-off field. The new beam then normally appears externally with a small search of frequency.

There is charge exchange during acceleration due to the tank pressure of about  $4 \times 10^{-6}$  mm. The resulting loss in beam is a factor of 2-4.

Two diffusion pumps have been added to the dee tank to reduce this pressure, but it would be best to have a larger pump on the dee tank, rather than on the RF panel tank as at present.

#### STANDARD INTERNAL ION SOURCE

The internal ion source used since the cyclotron first operated in 1961 was developed by Ehlers.<sup>1</sup> Photos of it are shown in Figs. 1 and 2. It is quite reliable in producing beams of protons, deuterons, He<sup>3</sup> and  $\alpha$ -particles. The available currents of these ions are generally more than the deflector can handle--internal beams of up to 5 ma of protons and deuterons, and 100-500  $\mu$ A of He<sup>3</sup> and  $\alpha$ -particles. The filament life is about a week on He<sup>3</sup> and  $\alpha$ -particles, and much longer on protons and deuterons.

This source has been used also for heavier ions for the past several years. But the usable arc power was limited to about 500 watts because of limited anode cooling, and the filament life was reduced to a few hours due to heavy ion sputtering. We improved the cooling by extending the water cooling from the bottom up around the top of the anode. This increased the useful arc power from 500 to about 800 watts. Thicker filaments were made, giving lifetimes of 4-12 hours on heavy ions. The best results for beam currents of heavy ions are shown in the upper section of Table 1. The source is usually run at lower output to conserve filament life.

Ion Source	Ion	Energy (MeV)	Harm. No.	Anode Slit (in) <sup>2</sup>	External Beam ( $\mu$ A)
Standard Filament Type	N <sup>3+</sup>	60	3	.080x.440	4
	N <sup>4+</sup>	160	1		3
	N <sup>5+</sup>	250	1		0.03
	O <sup>3+</sup>	52	3		16
	Kr <sup>5+</sup>	36	5		0.02
PIG Type	N <sup>4+</sup>	160	1	.090x.120	10
	N <sup>5+</sup>	250	1		7

Table 1. Best performance of 88-Inch Cyclotron ion sources on heavy ions.

#### INTERNAL PIG SOURCE

After the above improvements in the standard filament type source, the beam currents of the most useful heavy ions of N<sup>4+</sup>, N<sup>5+</sup>, and O<sup>3+</sup> were much less than those reported by workers at cyclotrons using PIG sources. Some of these are the Dubna group,<sup>3</sup> Bennett at Harwell,<sup>4</sup> the IPCR Tokyo group,<sup>5</sup> and the Oak Ridge ORIC group.<sup>6</sup> The high beam currents apparently come from the higher arc power which is available from the larger area of the cathodes used, compared with the small area of emitting filament in our standard source. The high arc power provides a higher flux (current) or higher energy (voltage) for electrons to produce the high charge states.

The PIG sources operate best when both cathodes are connected together to a negative high voltage supply, rather than with a floating cathode as in our present filament source. Various cyclotrons use different methods of connecting the cathodes. The Dubna and Tokyo groups bring the source in the side of the cyclotron magnet, and make connection with a



separate tube to each cathode. The ORIC source is side mounted, but uses only one tube and makes a connection inside the anode between cathodes. The Harwell source is mounted axially through the upper pole, and makes connection with a probe through the lower pole to the lower cathode. In the case of the 88-Inch Cyclotron, the source is mounted axially through the lower pole. It would be difficult to bring a probe through the upper pole to the upper cathode because the axial injection transport line for external sources is located there. The connection of the cathodes inside the anode was working well at Oak Ridge, so it looked like the best system for us.

The design of the source is shown in the schematic drawing, Fig. 3, and in the three photos of Figs. 4, 5, 6. The cathodes are connected by a copper water cooling tube which fits inside the anode. Each cathode is held in a copper water-cooled holder with a set screw. When the source was first operated, the copper tube connecting the cathodes showed signs of wear by sputtering from the ExB discharge around it. A tapered tantalum bar was attached to it to dump the discharge along the magnetic field. Since the sputtering was still present, the copper tube was wrapped with tantalum foil, which shows no signs of sputtering wear. A bar was added on the tantalum side cover to prevent the dumped electrons from hitting the lower insulator. The base insulator was originally an alumina-epoxy mixture, which suffered from serious high voltage surface breakdown, due to outgassing. When this was replaced with cast alumina, the problem was solved. A boron nitride insulator is dropped into a groove in the base alumina. It can be easily removed for cleaning or replacement and avoids chemical reaction between alumina and condensed tantalum. The anode is water-cooled copper.

A replaceable tantalum slit is used for beam extraction. A tantalum top cap is pushed on to form a gas seal and to hold the side tantalum cover in place.

The source produced beam in September 1971 and has been in the testing and debugging phase since then. It has been run mostly on nitrogen, and the lower part of Table 1 shows the best beam results obtained. For  $N^{4+}$  and  $N^{5+}$  the beam currents are about 10-100 times larger than with the standard filament source, per unit slit area. Beam current is nearly proportional to slit area. The  $N^{5+}$  beam is much cleaner in the internal beam region due to less spurious  $N^{1+}$ , making it much easier to tune up with the PIG source. The main problem remaining is to improve the cathode life. At present the cathodes have to be replaced every 2-3 hours, because the arc is extinguished by the deep craters in the cathodes. Trials are being made of running the arc at lower voltage than the present 800-1000 volts to increase the cathode life.

The power supply for the source is our standard magnetic amplifier controlled arc supply, with a starting voltage of 3 kV. The gas flow is increased until the arc strikes to give about 800-1000 volts and 3-4 amps. The gas is then reduced to give maximum beam. This occurs at the minimum flow which will keep the arc alive for  $N^{4+}$  and  $N^{5+}$ . A series resistor of about 400 ohms is used to stabilize operation and limit the current.

One disadvantage of internal sources is the gas-load produced in the center region. For the PIG source however, there is a self-pumping effect due to high arc current, which converts 80-95% of the gas into ions.

### EXTERNAL LITHIUM SOURCE DEVELOPMENT

Since the last report on the external source in March 1971<sup>2</sup> the decision was made to develop an internal PIG source for most heavy ion beams, because the transport problems down the axial injection line for the external source can be eliminated. The external source would be developed for ions which would be difficult to run internally. The first requirement was for lithium, which would cause sparking and cleaning problems in the center of the cyclotron if used in an internal source.

A stainless steel furnace was built to produce lithium vapor for the arc. Basic requirements in the design of the furnace were: high enough temperature to vaporize the lithium ( $\sim 600^\circ\text{C}$ ), temperature gradient to prevent the molten lithium from flowing outside, and corrosion resistant materials like austenitic stainless steel and tantalum.<sup>7</sup> The electric current flows through the .06 in. diameter tantalum wire coil used as a heater, and through the pipe (0.125 in., 0.016 in. wall) transporting the lithium vapor to the arc chamber. The stainless-steel pipe is warmer than the oven to prevent condensing. The top plug closing the oven is sealed by the use of a tantalum gasket. A hollow in that plug contains the thermocouple head.

Thus far beams of 200  $\mu\text{A}$  of  $\text{Li}^+$  and 40  $\mu\text{A}$  of  $\text{Li}^{2+}$  have been obtained from the source running at 2 kV and 0.7 A. A small beam of a few nanoamps of  $\text{Li}^{2+}$  has been injected and accelerated in the cyclotron up to 80 MeV, but not extracted. More work on the system is planned to produce usable lithium beams for reaction experiments. A beam of about 20  $\mu\text{A}$  of  $\text{Li}^{2+}$  is available at the bottom Faraday cup of the injection line and up to 100 nA might be extracted from the cyclotron after all the tuning is optimized.

The first tests were made with nitrogen as a support gas at a flow of about 2 cc/min and the oven heated at 660°C. Hazardous lithium nitride powder ( $\text{Li}_3\text{N}$ ) is produced inside the arc chamber making the cleaning and operation of the source difficult. Use of helium as a support gas is thus recommended.

#### ACKNOWLEDGMENTS

The authors wish to acknowledge the help of Matt Renkas and Bob Druet of the 88-Inch Cyclotron electronic engineering group under Phil Frazier, the assistance of the mechanical technicians under Frank Hart and Wayne Olthoff, the help of the 88-Inch crew during source testing, and the careful drafting work of Larry Bell. We also wish to thank M. Mallory and E. Hudson of Oak Ridge National Laboratory for helpful discussions and for sending us their ion source drawings, and J.R.J. Bennett for valuable discussions on PIG sources.

FOOTNOTES AND REFERENCES

\*Work performed under the auspices of the U.S. Atomic Energy Commission.

† On leave of absence from University of Louvain and IISN, Belgium-NATO Fellowship.

1. K. W. Ehlers, Nucl. Instr. Methods 18, 571 (1962).
2. D. J. Clark, et al., IEEE Trans. Nucl. Sci. NS-18, 102 (1971).
3. P. M. Morozov, et al., Atomnaya Energiya 2, 272 (1957).
4. J. R. J. Bennett, Fifth International Cyclotron Conf., 1969, p. 499 (Butterworths, London, 1971).
5. Y. Miyazawa, et al., Japanese Journal of Applied Physics 9, 532 (1970).
6. E. D. Hudson, et al., IEEE Trans. Nucl. Sci. NS-18, 113 (1971).
7. P. I. Vasiliev, et al., Nucl. Instr. Methods 71, 201 (1969).

FIGURE CAPTIONS

- Fig. 1. Standard 88-Inch Cyclotron internal ion source mounted on shaft which goes through lower pole of cyclotron. Scale in inches.
- Fig. 2. Standard internal ion source disassembled, showing filament structure, anode and anti-cathode button and insulator.
- Fig. 3. Drawing of new internal PIG ion source showing various parts in two sections.
- Fig. 4. New internal PIG ion source mounted on shaft.
- Fig. 5. New internal PIG ion source partially disassembled, showing cathode structure in place. Anode, Ta side cover and top cap are removed.
- Fig. 6. New internal PIG ion source disassembled showing cathode structure, anode, Ta side cover and top cap.
- Fig. 7. Drawing of external PIG source in 2 sections, showing source and new lithium furnace. Source is installed vertically with the arc chamber at the bottom.

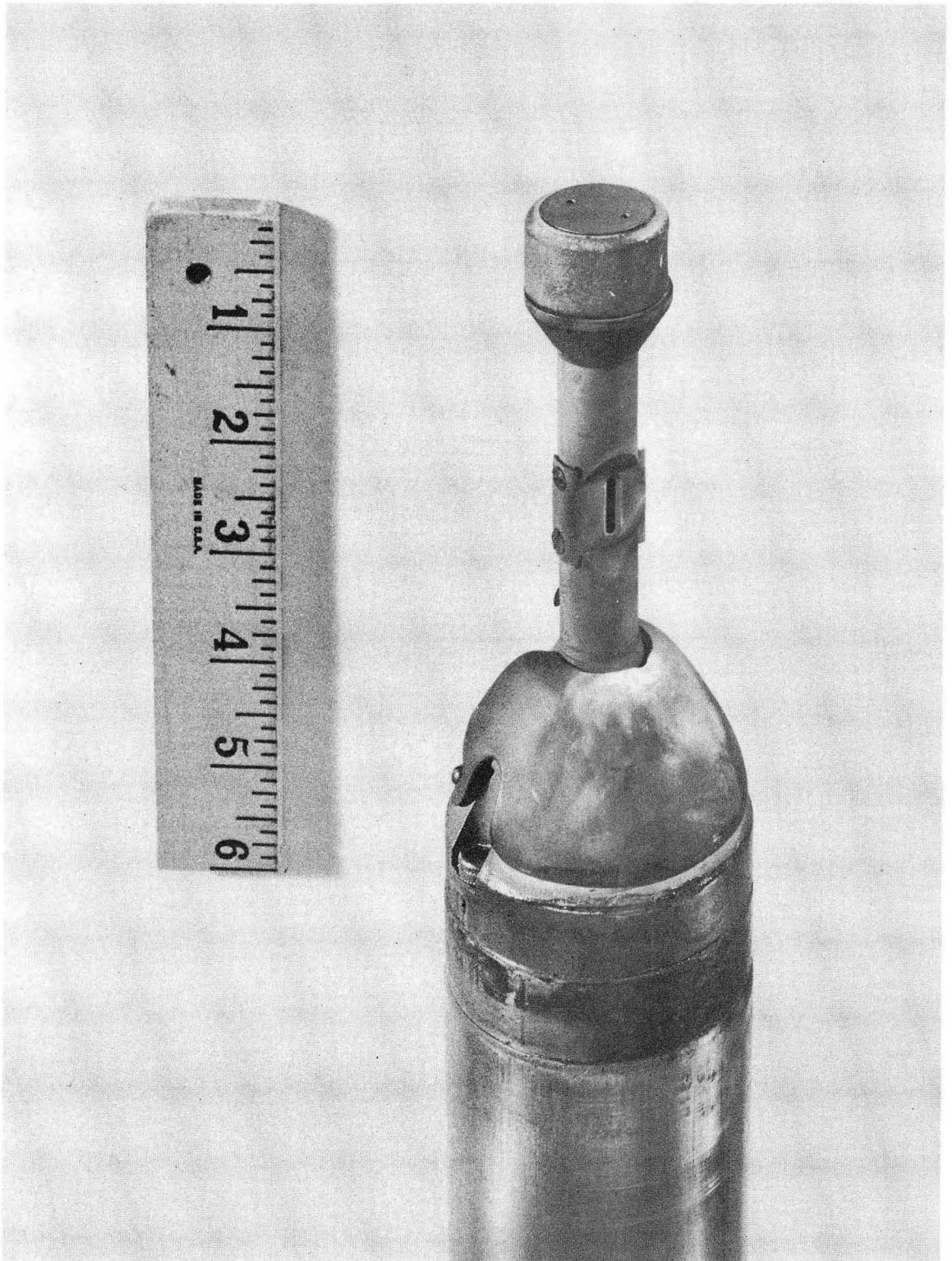

CBB 7110-4842

Fig. 1

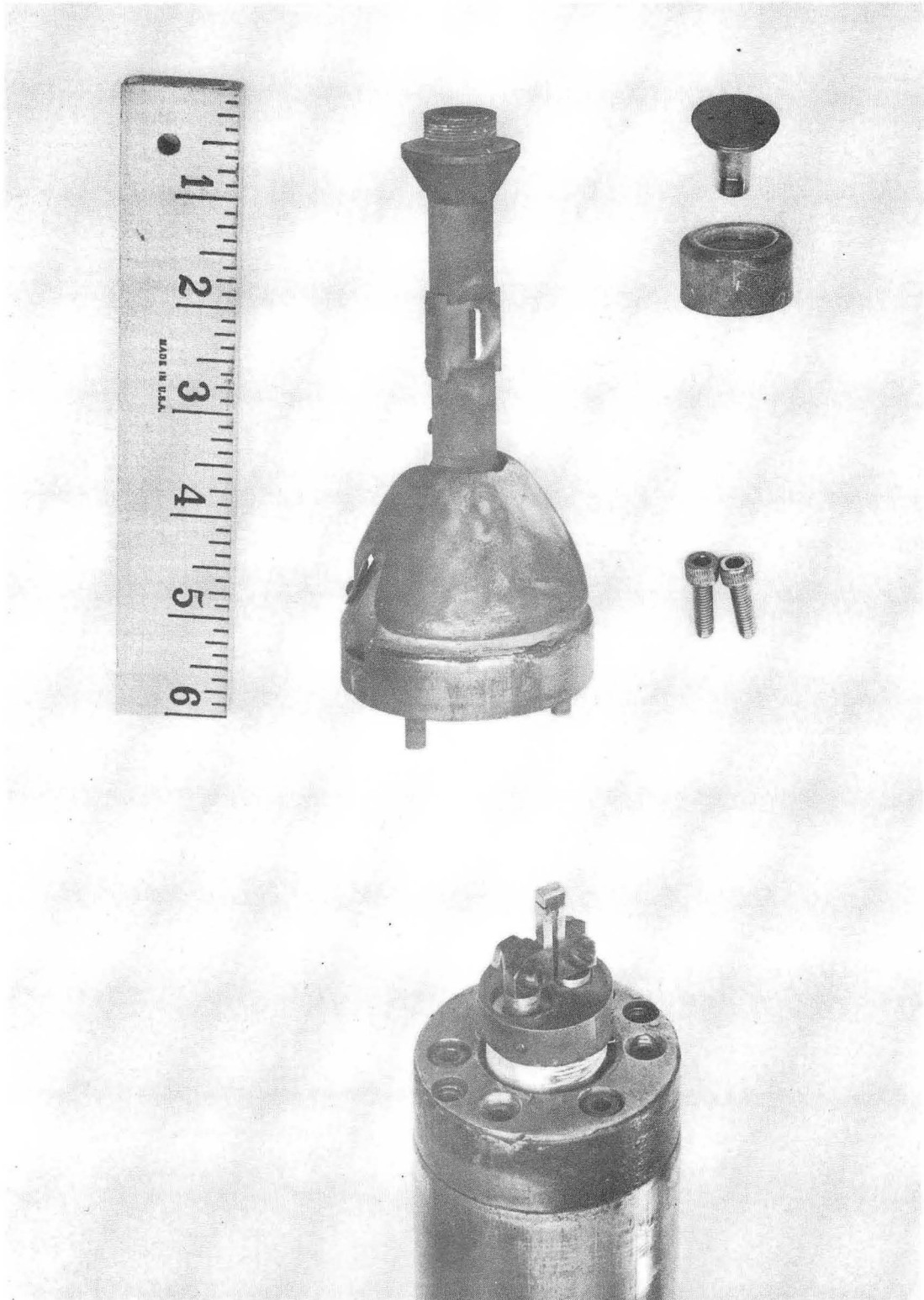

CBB 7110-4836

Fig. 2



FIG. 3

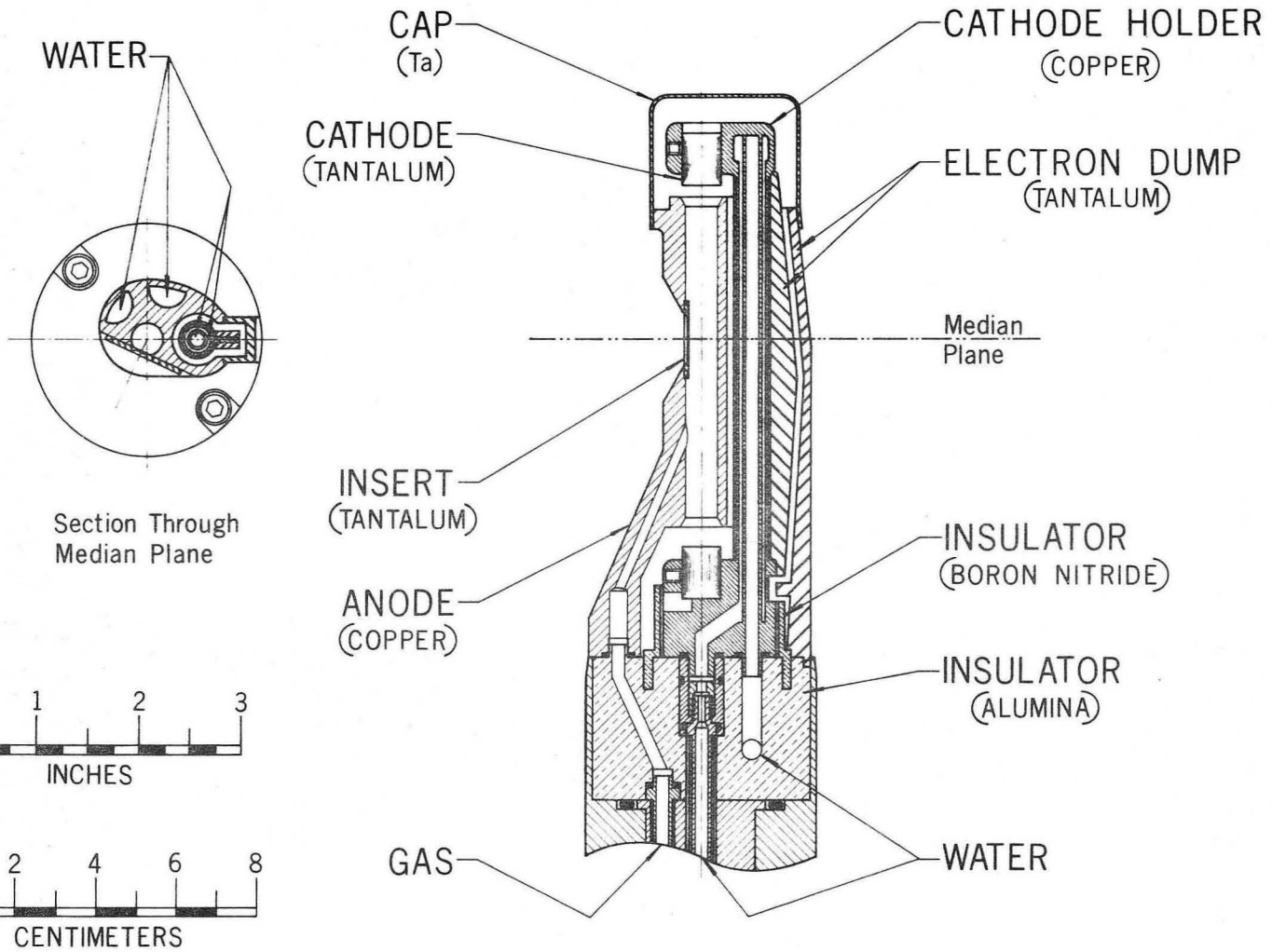

INTERNAL P.I.G. SOURCE

XBL 7110-1536

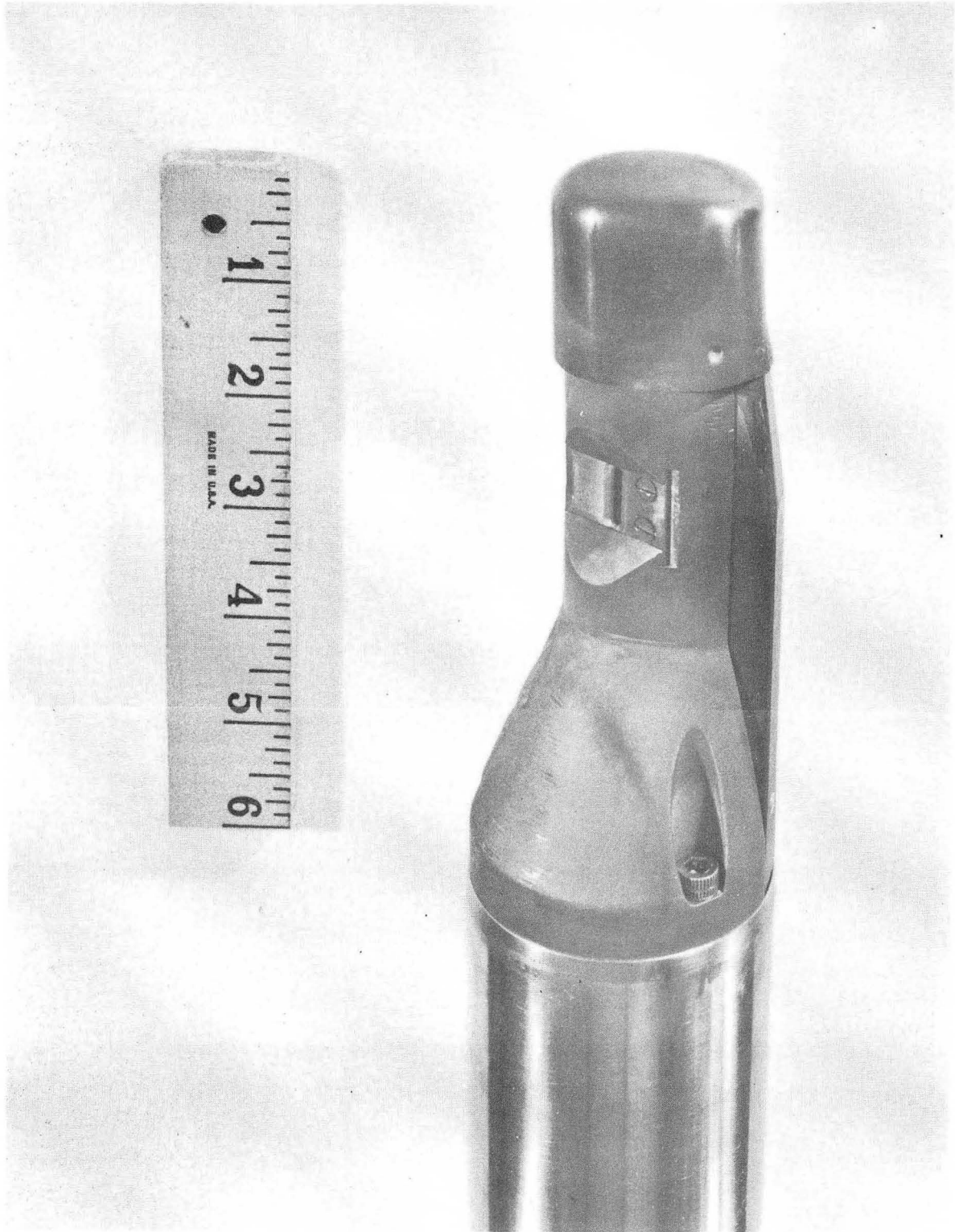

Fig. 4

CBB 7110-4844

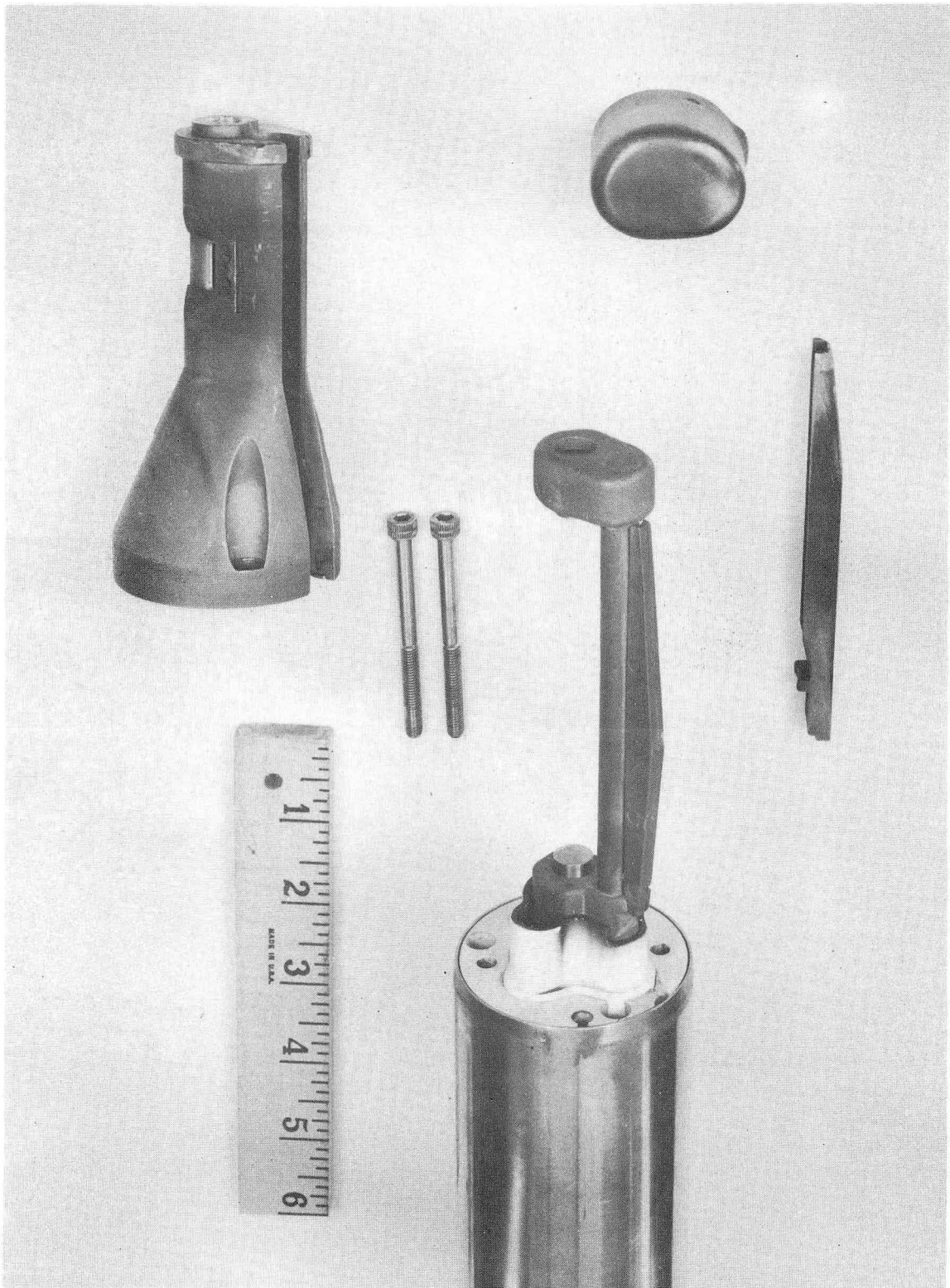

Fig. 5

CBB 7110-4838



Fig. 6

CBB 7110-4840

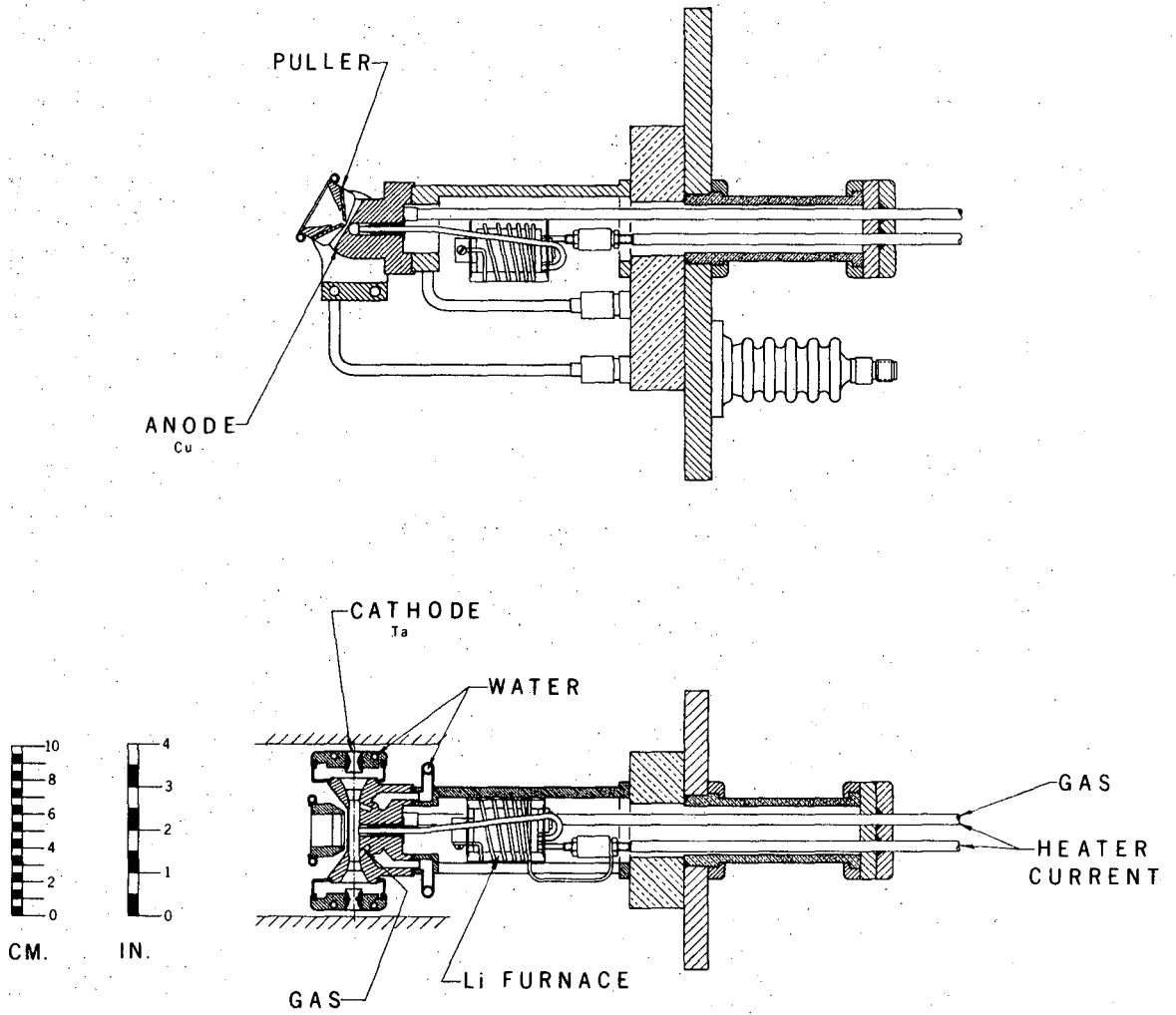

EXTERNAL P.I.G. SOURCE

XBL 7440-4535

Fig. 7

LEGAL NOTICE

*This report was prepared as an account of work sponsored by the United States Government. Neither the United States nor the United States Atomic Energy Commission, nor any of their employees, nor any of their contractors, subcontractors, or their employees, makes any warranty, express or implied, or assumes any legal liability or responsibility for the accuracy, completeness or usefulness of any information, apparatus, product or process disclosed, or represents that its use would not infringe privately owned rights.*

TECHNICAL INFORMATION DIVISION  
LAWRENCE BERKELEY LABORATORY  
UNIVERSITY OF CALIFORNIA  
BERKELEY, CALIFORNIA 94720