

UC Riverside

UC Riverside Electronic Theses and Dissertations

Title

Design and Evaluation of a Multimedia Scaffolding System for Teaching Statics

Permalink

<https://escholarship.org/uc/item/2981b6pd>

Author

Chu, CHUN-HAN

Publication Date

2014

Peer reviewed|Thesis/dissertation

UNIVERSITY OF CALIFORNIA
RIVERSIDE

Design and Evaluation of a Multimedia Scaffolding System for Teaching Statics

A Thesis submitted in partial satisfaction
of the requirements for the degree of

Master of Science

in

Mechanical Engineering

by

Chun-Han Chu

December 2014

Thesis Committee:

Dr. Thomas Stahovich, Chairperson

Dr. Sandeep Kumar

Dr. Heejung Jung

Copyright by
Chun-Han Chu
2014

The Thesis of Chun-Han Chu is approved:

Committee Chairperson

University of California, Riverside

Acknowledgements

I would like to thank my adviser, Dr. Stahovich, for offering me the opportunity to work in Smart Tools Lab. I always want to learn computer science; having the chance to work in a lab that calls for collaboration between Mechanical Engineering and CS is the perfect solution to my desire. Thank you for your guidance all along. Even a casual chat about your weekend hobby, either creating a batch file to facilitate classifying Excel spreadsheets or hacking Raspberry Pi with household appliance, could in fact inspire me greatly. You certainly turn learning into joy and show how much a person can achieve when equipped with the power of knowledge.

Thanks to Kevin and Matt for their assistance in the lab. Thanks to Justin for his help during the experiment with students in ME2 and for all the narration for my tutorial videos. Big thanks to Hank for always being there for us when there were bugs to be fixed and features to be added in the program, as well as having enough patience to (repeatedly) answer my every troubled and trivial question for two years, research or non-research, on or off campus.

Thanks to my three PhD roommates, Claire, Huy and Mike, for their help when I encountered problem in CS topics. More than often after midnight I would walk up to the second floor of our house and bugged them with any questions I had before they spitted out answer in seconds. Also thanks to Mike, a.k.a. my landlord, for generously letting me defer the rent whenever my hands were tight.

Thanks to my two big sisters, who have been concerned with my well-being more than anything else, especially when I first came to US. Thanks to my parents, who always look after me regardless of how old or where I am, and allow me to pursue whatever I want to do. Thank you all for believing in me.

Finally, thanks to my soon-to-be wife, Shin-Wei Chen, who always cheered me up through countless of video chats from the other side of the globe, at the same time devoted much effort to blend into my family and bring me peace of mind. You are the best woman a guy could ever wish for.

ABSTRACT OF THE THESIS

Design and Evaluation of a Multimedia Scaffolding System for Teaching Statics

by

Chun-Han Chu

Master of Science, Graduate Program in Mechanical Engineering
University of California, Riverside, December 2014
Dr. Thomas Stahovich, Chairperson

Newton's Tablet is an intelligent tutoring system for teaching Statics developed at the Smart Tools Lab at UC Riverside. Newton's Tablet uses a *reactive teaching* approach; that is, it provides feedback when the student makes an error. The program helps students decompose a statics problem into problem-solving steps and provides assistance to students when they make mistakes completing a step. The system also has a database of conceptual help that users can reference.

This research project has two parts. The first is to evaluate the effectiveness of Newton's Tablet. To do this, we conducted the experiment with students from ME 002, Introduction to Mechanical Engineering. About 80 students participated in this experiment. We used pre- and posttests to evaluate the effectiveness of the program. This study demonstrated that the system does produce learning gains.

The second part of this project is designing and creating a scaffolding system for use with Newton's Tablet. We extended Newton's Tablet by providing additional scaffolding to teach statics concepts to students via a set of tutorial videos designed to guide students through the problem-solving process. The scaffolding presents concepts by explaining a worked example. Students then apply what they learn from the videos to solve new problems. The videos transform Newton's Tablet into an *active* teaching system.

We conducted a study to evaluate the usefulness of Newton's tablet combined with the new scaffolding system. In this study, the experimental group used Newton's Tablet with the instructional videos, while the control group was provided with traditional paper-based instructional materials containing the same content as the videos. We compare the learning gains of both groups using pre- and posttests. Students using the tutoring system with the videos had significantly larger learning gains than the students who used the paper-based materials.

Table of Content

1. Introduction.....	1
2. Background.....	3
3. Study 1: Evaluation of Newton’s Tablet.....	5
4. Study 1: Evaluation Result	17
5. Study 2: Design and Evaluation of Effectiveness of a Multimedia Scaffolding Technique	30
6. Study 2: Experimental Design	43
7. Study 2: Results	50
8. Conclusion	61

List of Figures

2.1	Screenshot of Newton's Tablet	3
3.1	Newton's Tablet under Book Mode	6
3.2	L-Beam	8
3.3	Bolted	9
3.4	Truck	9
3.5	An original log file from Tutorial Mode	10
3.6	Screenshot of Log File Info Extractor	10
3.7	Problem for all three tests	13
4.1	Percentage of correct rate on tests for both groups	18
4.2	Average score in the tests	18
4.3	Comparison of FBD scores in tests for both groups	19
4.4	Comparison of Moment equation scores in tests for both groups	20
4.5	Percentage of students in Group A attempted constructing moment equation and the corresponding errors during Pre-test	21
4.6	Percentage of students in Group A attempted constructing moment equation and the corresponding errors during Mid-test	21
4.7	Percentage of students in Group A attempted constructing moment equation and the corresponding errors during Post-test	22
4.8	Percentage of students in Group B attempted constructing moment equation and the corresponding errors during Pre-test	23
4.9	Percentage of students in Group B attempted constructing moment equation and the corresponding errors during Mid-test	23
4.10	Percentage of students in Group B attempted constructing moment equation and the corresponding errors during Post-test	24
4.11	Actual usage of Newton's Tablet	25
4.12	Fraction of students in Group A completing each step correctly during Tutorial Mode	26
4.13	Fraction of students in Group A completing each step correctly during Book Mode	26
4.14	Fraction of students in Group B completing each step correctly during Book Mode	27
4.15	Fraction of students in Group B completing each step correctly during Tutorial Mode	27
5.1	The modified L-Beam problem	31
5.2	Representing the problem with boundary and corresponding forces	32
5.3	Illustration of summarizing all microscopic force acting on an object into one force on a specific point	33
5.4	Illustration for explanation of internal force	34
5.5	Difference between the two boundaries	34
5.6	Representing external supports as points of interaction	35
5.7	Classification of points of interaction on the L-beam	35
5.8	Forces acting on a pivot	36

5.9	Forces acting on a roller	36
5.10	Cable	37
5.11(a)	Spring under compression, pushing the object	37
5.11(b)	Spring under tension, pulling the object	37
5.12	Applied force	38
5.13	Representing the original POIs with force distribution	38
5.14	Free body diagram for the L-Beam problem	39
5.15	Using different color code to show whether individual force has component in X direction	39
5.16	Decomposing force C into components C_x and C_y	40
5.17	Showing the moment arm L_1 for Force B. Please note that we are showing swinging arm action for a clearer and more straight-forward representation	41
5.18	(Left) The moment arm for A_x is L_2 . A_x tends to cause clockwise rotation about C. (Right) The moment arm for A_y is L_3 . A_y also tends to cause clockwise rotation about C.	41
6.1(a)	Normal working mode of Newton's Tablet	43
6.1(b)	With animation sub-window shown	43
6.2	Problem image for the pre- and post-test	46
7.1	Comparison of test score for both group between pre- and post-test	51
7.2	Comparison of equations scores in pre- and post-test for the experimental group	52
7.3	Comparison of equations scores in pre- and post-test for the control group	53
7.4	Percentage of students successfully constructed sufficient equations to solve the problem	54
7.5	Percentage of students who attempted solving the problem	55
7.6	Grades of FBD for experimental group	55
7.7	Grades of FBD for control group	56
7.8	Percentage of students who successfully completed FBD among all who tried	57
7.9	Example of test sheet from participants	58
7.10	Example of test sheet from participant	59
7.11	Percentage of students in both groups who showed having the correct concept	60

List of Tables

3.1	Groupings of students with different modes and date	7
3.2	Temp file to be post-processed	11
3.3	Key information of assignment from students derived from raw log files	12
3.4	Log files from Book Mode	12
3.5	Rubric for grading FBD	14
3.6	Rubric for grading moment equation	16
4.1	Correlation for Group A students after using Tutorial Mode	29
4.2	Correlation for Group B students after using Tutorial Mode	29
6.1	The list of videos played at different stages of the program	45
6.2	Grading rubric for FBD and moment equation for pre- and post-test	47-48
6.3	Rubrics for grading multiple equations	48-49
7.1	Number of students participated	50
7.2	Distribution of participants according to different majors	50

Chapter 1

Introduction

Computers have been around for decades. Ever since people found use of computers outside numerical computation, people have used the magic box for virtually all aspects of our lives, including education. The term “computer-assisted education” surfaced as early as in 1973 [1], but it wasn’t until the 1990s, when the computer started to make its way to households and schools, that this concept became gradually popularized. As computers became more affordable, more classrooms were able to offer computers to students. In fact, in a survey conducted in 2009, around 97 percent of instructors had at least one computer stationed in the classroom every day [2].

Intelligent Tutoring System

An intelligent tutoring system is a computer system that provides automated feedback or instruction to users on an educational basis [3]. Notable examples include ELM-ART [4], CIRCSIM-Tutor [5] and AutoTutor [6]. Here, we set out to make tutoring tools available to students receiving post-secondary education in mechanical engineering. In this research project, we focus on Statics, an introductory course required for undergraduates in the mechanical engineering and several other engineering disciplines.

Pen-based Computing

A traditional computing environment consists of input and output devices whereas the input comes from mainly a keyboard and mouse. *Pen-based computing*, on the other hand, refers to computer interfaces that use a stylus or touch-enabled screen. After the consumer market boomed for mobile devices and tablet computers such as the iPad® and Surface® RT in recent years, pen-based computing has since become more prominent. In addition, for educational purposes, there are frequent occasions that the users or students feel more adept at using “writing” than having to deal with a mouse and keyboard to provide input. Consequently, our research focuses on the application of pen-based technology for the assistance of students’ learning.

Structure of this Project

The structure of this thesis is outlined as the following: in Chapter 2 we go through the background and previous attempt, where in Chapter 3 we explain the detail of our first study, or Study 1, regarding the re-evaluation of Newton’s Tablet. The results of Study 1 are presented in Chapter 4.

We then propose an additional scaffolding system with which we extend the current version of Newton’s Tablet in Chapter 5, as well as highlighting the essential concepts provided in our tutorial animation set. Chapter 6 describes the experimental design of Study 2; that is, the evaluation of such scaffolding system in use with Newton’s Tablet. Chapter 7 presents the results from Study 2, while Chapter 8 shows our conclusion.

Chapter 2

Background

Newton's Tablet

During 2013, Levi Lindsay from the Smart Tools Lab devised a tutoring system, Newton's Tablet, with the goal of helping undergraduate students gain a better understanding of Statics. The program was written in C# on the Microsoft .NET[®] platform with Windows Presentation Foundation, or WPF.

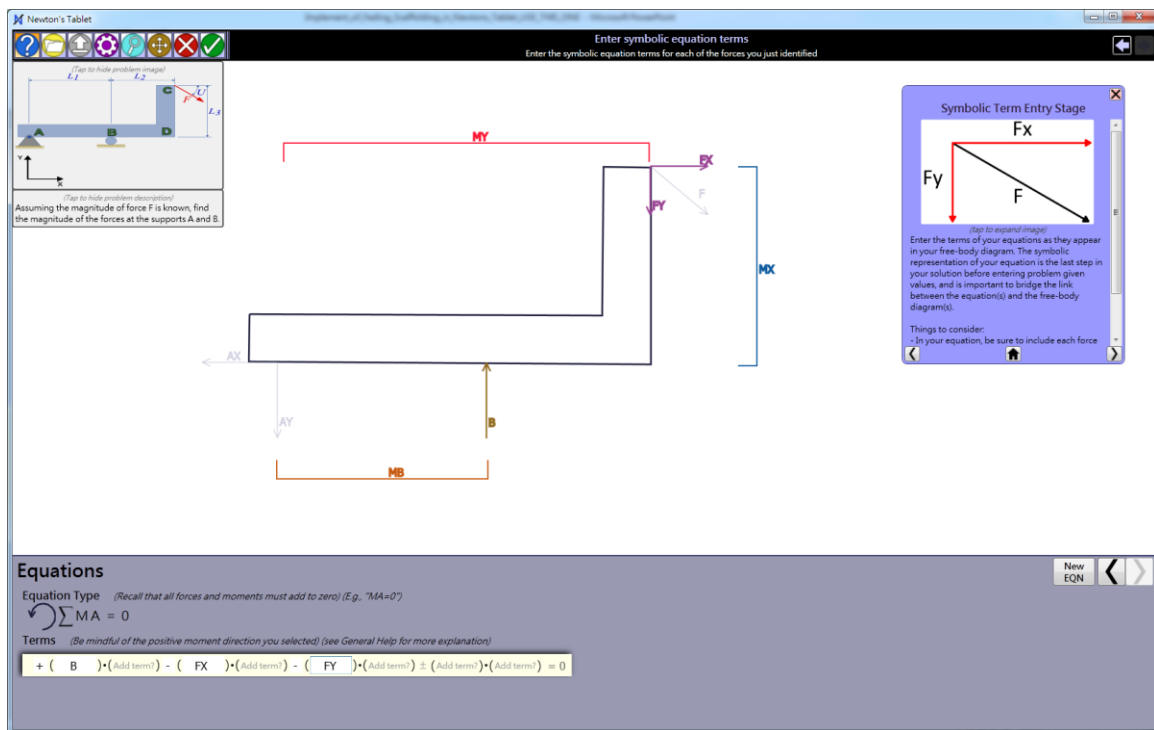

Figure 2.1: Screenshot of Newton's Tablet.

Previous Attempt

Garcia [7] conducted a user study in the winter and spring of 2013 to gauge the reception and usage of Newton's Tablet from undergraduate students enrolling in Statics at UC Riverside. During the user study, 18 of the students in winter reported having used Newton's Tablet, while 10 participated in spring. Afterward, we wanted to carry out the user study again with a larger number of students to gain a more objective result.

Outline for Experiment

Aside from evaluation of the software, we are also wanted to examine whether additional scaffolding system would differentiate students' learning performance from those who receive tutorial in traditional means, that is, in plain paper form.

To do this, we conducted a re-evaluation of Newton's Tablet in the spring of 2014. Then in fall 2014 we conducted a user study on a smaller scale to test the effects of a set of tutorial animations that accompanied the program. We will explain the detail of both experiments in the following chapters.

Chapter 3

Study 1: Evaluation of Newton's Tablet

To evaluate the effectiveness of Newton's Tablet on a broader scale, we chose the undergraduates enrolling in ME2, or Introduction to Mechanical Engineering, course in UC Riverside in spring 2014 as the examinees. Because the students have not yet taken Statics, they are the most suitable candidates to test the program.

The main concept of the experiment is simple: we ask one set of students to complete the assignment on Newton's Tablet while having the other group finish the same set of problem with no assistance. Afterward we gave them a post-test and compare the difference between the grades. However, due to fairness reason, we cannot simply divide students into experimental group and control group. Both groups accomplished their tasks outside of lecture.

Tutorial Mode, Book Mode and Mid-test

To make sure that all of the students receive the same degree of guidance along the course, we decided to let them "take turns". To do this, we divided the experiment into two phases. Before the experiment began, we first gave students a pre-test as a reference for later analysis, and we proceeded to phase one. During phase one, we separated the students into two random groups, namely A and B. While the group A students received

the assistance of the tutorial system, group B students solved the problems without additional help and tips. Furthermore, to prevent students from having concerns about initially receiving less guidance, we did not inform the students about which groups they would be assigned to. We also included another program mode, the *Book Mode* (Figure 3.1), in Newton's Tablet that only offers a screenshot of the problem and text boxes for answer insertion. Certain buttons were removed. This differs from the original guidance mode, or as we called, the *Tutorial Mode*. Both modes have approximately the same working environment and interface to achieve the lowest visual difference between modes.

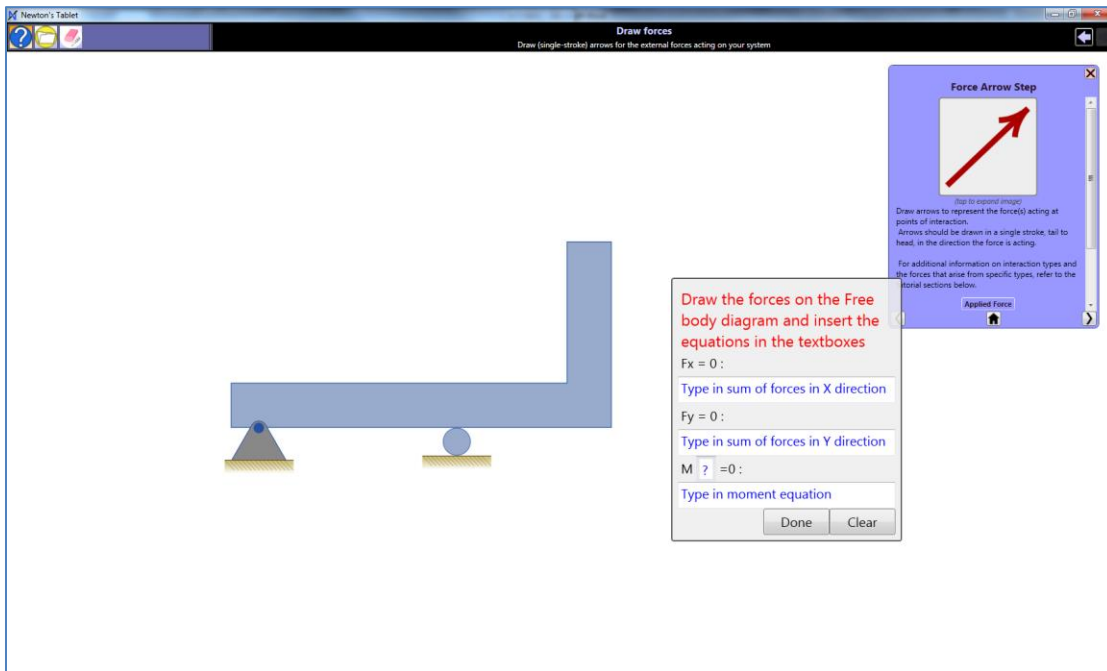

Figure 3.1: Newton's Tablet under Book Mode.

After both groups used the program for approximately forty hours, they completed phase one and received the second quiz, which is the *Mid-test* for its presence at the middle of the experiment. The mid-test was followed by phase two, which was a “switch” of modes. The original group A students now were offered the Book Mode while group B received assistance. Both groups concluded the phase two with the final quiz, or the post-test. The pre-test, mid-test and post-test used the same problem to simplify the factors in the experiment. We eventually conducted further analysis on the resulting data. The groupings are listed as Table 3.1 below:

	Mon(4/28)	Tue	Wednesday before lecture	Wednesday after lecture	Thur	Fri(5/2)
Group A	Tutorial Mode			Book Mode		
Group B	Book Mode			Tutorial Mode		

Table 3.1: Groupings of students with different modes and date.

Deployment of Newton’s Tablet

For confidential reasons, we prefer not to directly provide the executable file for students to download, so as to eliminate the possibilities of reverse engineering or tampering with log files. Unfortunately, due to the different availability of students and the limited amount of computers provided in our lab, it is not possible to ask all of the students to come in to the lab and use the program. In the end, we came up with the solution of utilizing the cloud computing service provided by Amazon[®] Elastic Compute Cloud, or EC2.

Since Amazon EC2 offers different operating systems, we were able to select Microsoft Windows Server 2008 as the main platform and therefore did not require any modification for the existing program to work. After we uploaded Newton's Tablet to the remote server, we offered students the remote desktop app that linked directly to the program. With careful settings, students' access was restricted to only the program, so that they were not able to modify any log files stored in the same folder. The program was hosted online for five days from 4/28 to 5/2.

Assignment

All students received the same three Statics problems along the experiment, which were L-Beam, Bolted and Truck (Figure 3.2~3.4). All three problems involve only single-body model in 2-D space and concepts that are not beyond rigid body equilibrium. Students were expected to identify different types of point of interactions, or POIs. Pivot joint and roller joint were among the mainly used types in the assignments. Friction is absent from all problems.

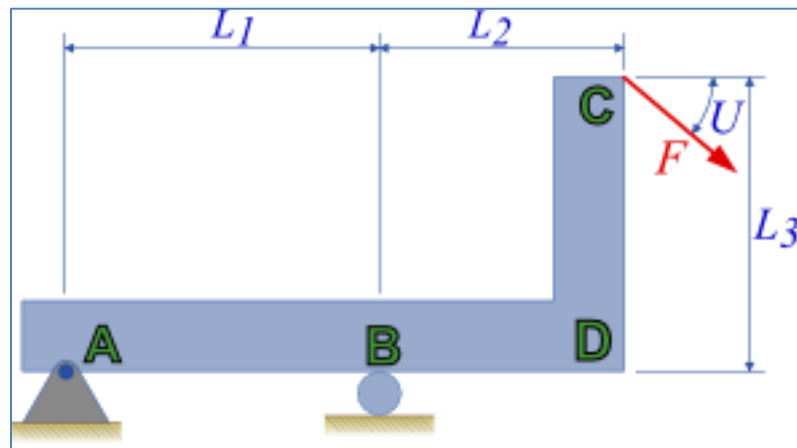

Figure 3.2: L-Beam.

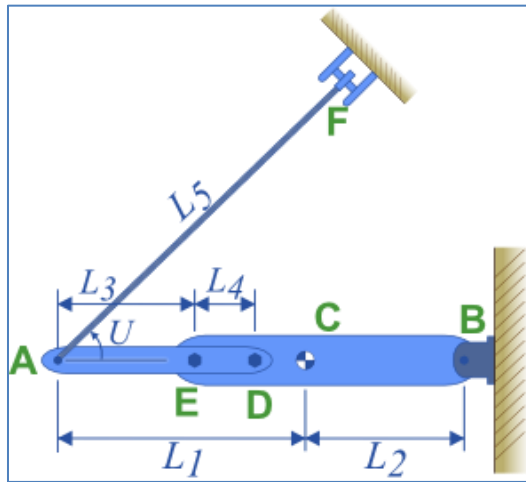

Figure 3.3: Bolted.

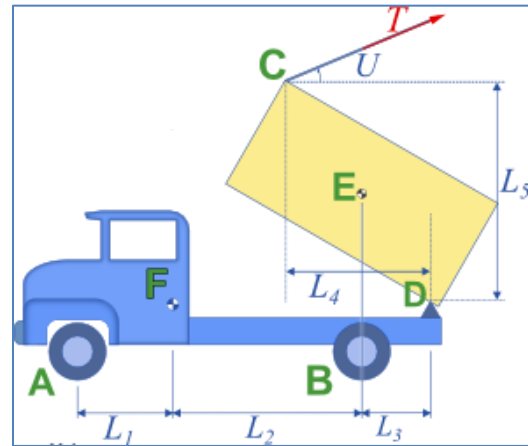

Figure 3.4: Truck.

Data Extraction of Log Files from Assignment

After the student used the program, log files were automatically generated and stored (Figure 3.5). We also have an upload button in the program for users to manually save the logs for their peace of mind. As a result, it was more than often that there were dozens of log files in a student's folder. To grade through all the work of students, a C# program was constructed specifically aimed for data extraction (Figure 3.6).

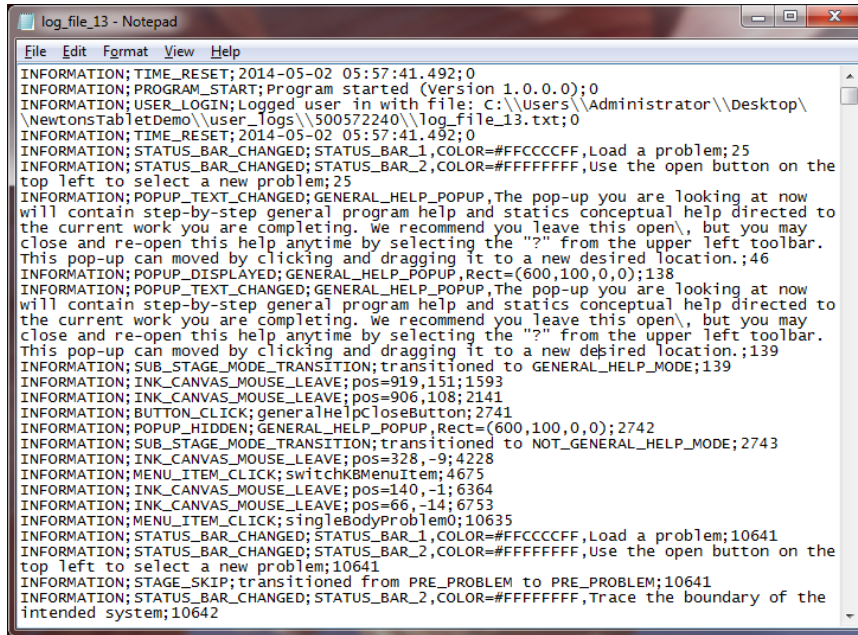

Figure 3.5: An original log file from Tutorial Mode.

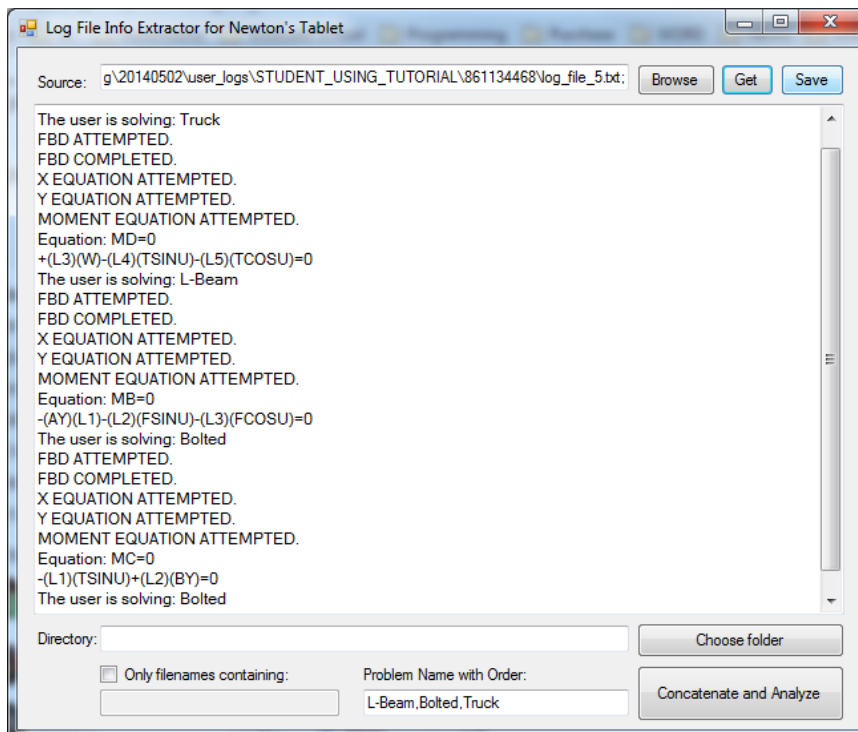

Figure 3.6: Screenshot of Log File Info Extractor.

The extractor program works as follows. We first grab all the log files under a student's folder and "stitch" them together to make a single huge text file, followed by picking out specific pattern of strings starting with keywords such as "STAGE_SKIP" and "TEXT_CHANGE". The whole chunk is then saved into a separate TEMP file in the form of Table 3.2.

```

=====START OF ANALYSIS=====
Student ID: 500572240
File name: log_file_1.txt
INFORMATION;MENU_ITEM_CLICK;singleBodyProblem0;21646
INFORMATION;MENU_ITEM_CLICK;singleBodyProblem1;33406
INFORMATION;MENU_ITEM_CLICK;singleBodyProblem3;46222
=====END OF ANALYSIS=====
=====START OF ANALYSIS=====
Student ID: 500572240
File name: log_file_2.txt
=====END OF ANALYSIS=====
=====START OF ANALYSIS=====
Student ID: 500572240
File name: log_file_3.txt
INFORMATION;MENU_ITEM_CLICK;singleBodyProblem0;8978
INFORMATION;STAGE_SKIP;transitioned from POI_CLASSIFICATION to FORCE_DRAWING;322373
INFORMATION;STROKE_CREATE
INFORMATION;MENU_ITEM_CLICK;singleBodyProblem1;1522340
INFORMATION;STAGE_SKIP;transitioned from POI_CLASSIFICATION to FORCE_DRAWING;1669918
INFORMATION;STROKE_CREATE
INFORMATION;STAGE_SKIP;transitioned from FORCE_DRAWING to EQN_TYPE_ENTRY;1729767
INFORMATION;TEXT_CHANGE;eqnTypeTextBox1: F;1740583
INFORMATION;TEXT_CHANGE;eqnTypeTextBox2: X;1741591
INFORMATION;TEXT_CHANGE;eqnTypeTextBox3: =;1742759
INFORMATION;TEXT_CHANGE;eqnTypeTextBox4: 0;1743607
.....

```

Table 3.2: Temp file to be post-processed.

With TEMP file in hand, the program loops through it again and makes a summary of whether the student completed each part of the problem (Table 3.3). The summary file is stored in the same folder as the log files.

```

Student ID: 500572240
The user is solving: Bolted
The user is solving: Truck
The user is solving: L-Beam
The user is solving: Bolted
FBD ATTEMPTED.
FBD COMPLETED.
X EQUATION ATTEMPTED.
MOMENT EQUATION ATTEMPTED.
Y EQUATION ATTEMPTED.

```

Table 3.3: Key information of assignment from students derived from raw log files.

After repeating the same process for all students, we moved all summary files into one directory and used the “Choose folder” / “Concatenate and Analyze” buttons on the extractor program to stitch the results again and save it into one .csv file for later analysis in Microsoft Excel. As for Book Mode, Newton’s Tablet generates a .jpg file containing the problem image of the students free body diagram and a text file containing three equations (Table 3.4). We graded these results manually. Students received one point for simply having attempted one item in the assignment. For our research purposes, we also assigned one point if they successfully completed it.

	$FX, -FIX + F \cdot \cos U = 0$ $FY, F1Y + F2Y - F \cdot \sin U = 0$ $MA, F2Y \cdot L1 - F \cdot \sin U \cdot (L1 + L2) - F \cdot \cos U \cdot L3$
Image file from Book Mode	Log file containing the equations

Table 3.4: Log files from Book Mode.

Problem for Test

For the test, we used a single-body equilibrium problem. The students' task was to find the tension in the cable (Figure 3.7). All lengths and the angle were assigned actual numeric values.

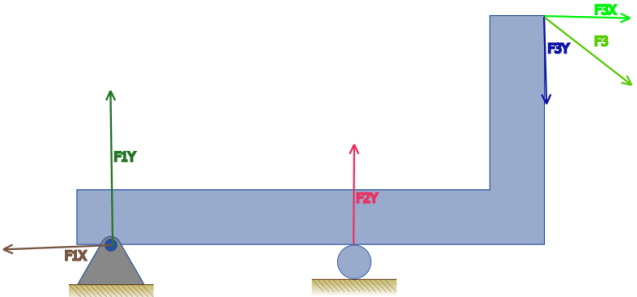
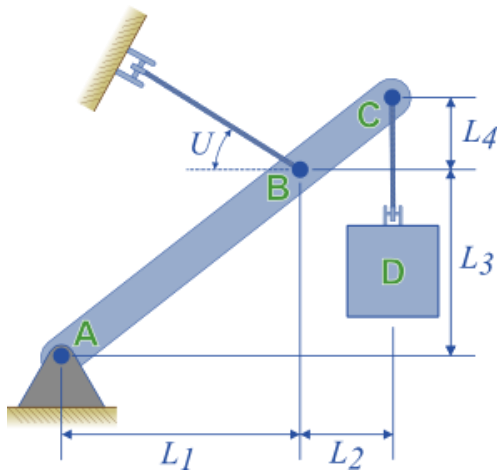

Figure 3.7: Problem for all three tests.

Grading Rubric for Test

We graded the students' test results according to the rubric listed in Table 3.5 and 3.6.

<p><u>Free body diagram:</u></p> <ul style="list-style-type: none">● Not attempted (-10 points)● Correct● Incorrect <ol style="list-style-type: none">1. Included external support<ol style="list-style-type: none">a. Included the pivot (-1 point)b. Included the cable (-1 point)2. Having extra force(s) (-1 point)3. Missing force label (if force is presented) (-1 point)4. Error with tension force<ol style="list-style-type: none">a. Missing tension force or component (-1 point)b. Tension force pointing in wrong direction (-1 point)5. Error with weight force<ol style="list-style-type: none">a. Missing weight force (-1 point)b. Wrong direction of weight force (-1 point)c. Did not include g (-1 point)6. Missing pivot force or component (-1 point)
--

Table 3.5: Rubric for grading FBD.

Moment equation:

- Not attempted (-20 points)
- Correct
- Incorrect
 1. Did not specify the positive direction of moment (-1 point)
 2. Did not successfully specify the reference point of moment (-1 point)
 3. Having extra moment terms (-1 point)
 4. Used forces that passed through the reference point (-1 point)
 5. Moment of weight force
 - a. Missing (-6 point)
 - b. Incorrect
 - i. Wrong sign (-1 point)
 - ii. Error with force
 - i. Wrong numerical value (-1 point)
 - ii. Did not include gravity (-1 point)
 - iii. Error with moment arm
 - i. Did not include arm (-1 point)
 - ii. Choose the wrong moment arm (-1 point)
 - iii. Did not correctly use parenthesis (-1 point)
 6. Moment of tension X-component
 - a. Missing (-5 point)
 - b. Incorrect
 - i. Wrong sign
 - ii. Error with force component
 - i. Wrong force label (-1 point)
 - ii. Wrong trigonometry (-1 point)
 - iii. Did not expand term (-1 point)
 - iii. Error with moment arm
 - i. Did not include arm (-1 point)

<ul style="list-style-type: none"> ii. Choose the wrong arm (-1 point) iii. Did not correctly use parenthesis (-1 point) <p>7. Moment of tension Y-component</p> <ul style="list-style-type: none"> a. Missing (-5 point) b. Incorrect <ul style="list-style-type: none"> i. Wrong sign (-1 point) ii. Error with force component <ul style="list-style-type: none"> i. Wrong force label (-1 point) ii. Wrong trigonometry (-1 point) iii. Did not expand term (-1 point) iii. Error with moment arm <ul style="list-style-type: none"> i. Did not include arm (-1 point) ii. Choose the wrong arm (-1 point) iii. Did not correctly use parenthesis (-1 point)
--

Table 3.6: Rubric for grading moment equation.

The free body diagram (FBD) portion of the problem contributes a total score of 10 points and the moment equation has a total of 20. One point is deducted for each mistake until all points for that part are subtracted. We then added up the scores from both parts to obtain the total score.

Chapter 4

Study 1: Evaluation Result

General test score

In the experiment, there were 43 students in group A and 45 in group B. During the pre-test, a total of 36 students from group A participated and 31 from group B. In the mid-test, 38 and 32 students took the test from each group. Finally, in the post-test, 33 and 31 students from each group submitted the test sheet. Figure 4.1 shows the percentage of students correctly finishing the test problem; the percentage is calculated as the ratio of the number of students completing the test problem with the correct answer to the total students in the same group. The average scores of students are shown in Figure 4.2.

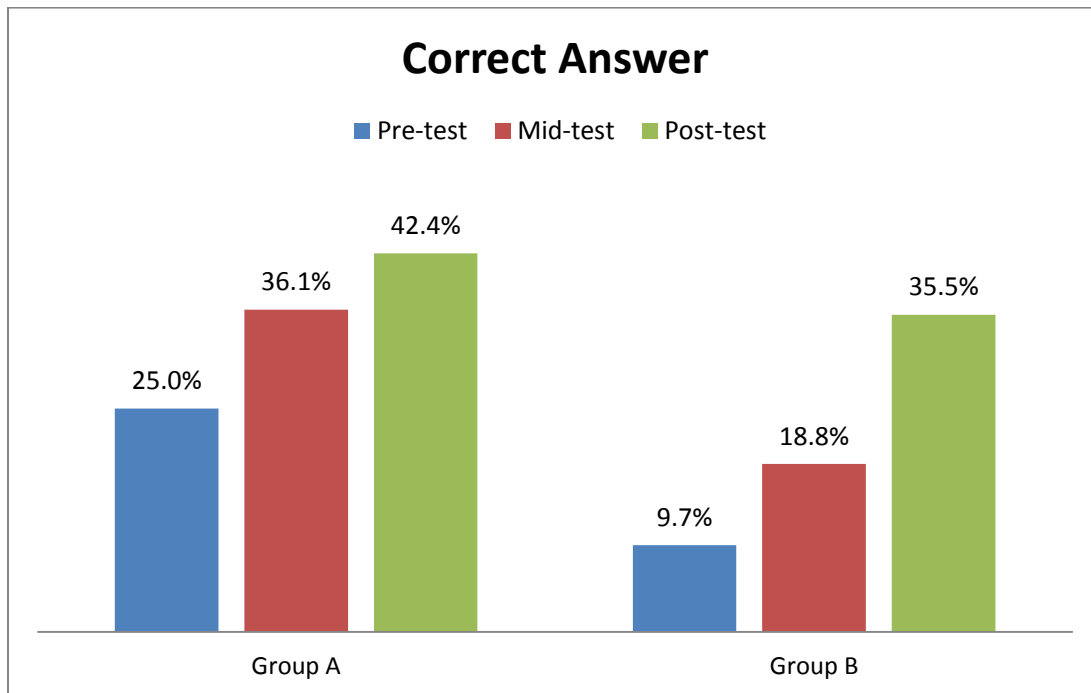

Figure 4.1: Percentage of correct rate on tests for both groups.

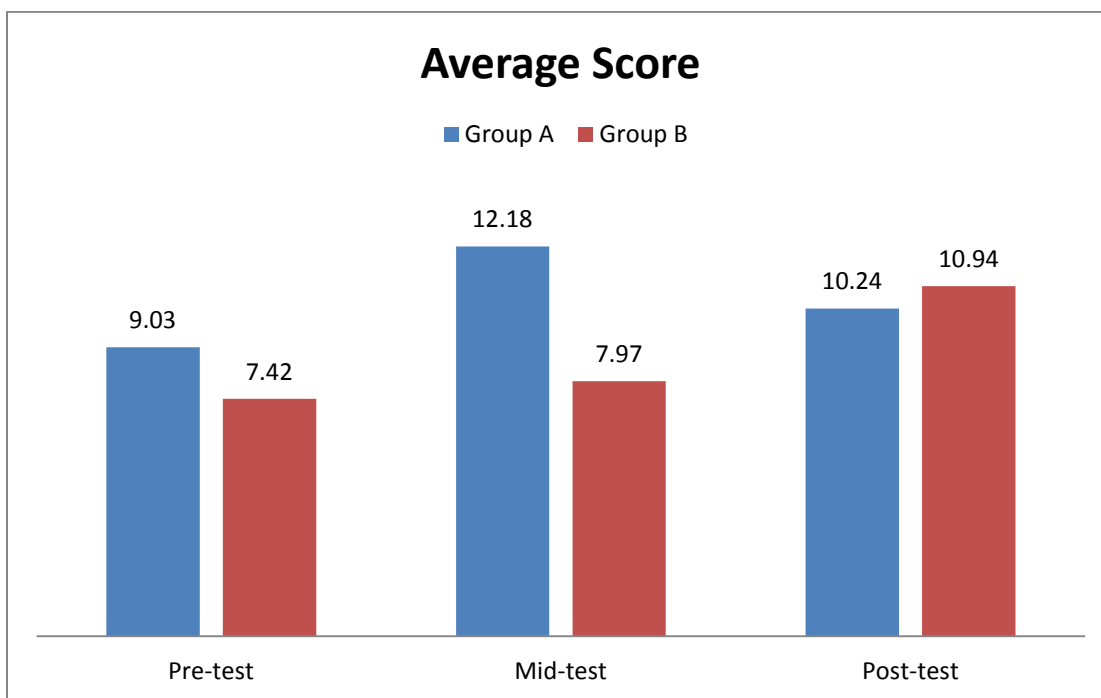

Figure 4.2: Average score in the tests.

At first sight, it seems that we did not have random groups because prior to having access to the tutoring system, the two groups had rather different successful completion rates in the pre-test. Nevertheless, we can see that students in Group B actually had a higher growth rate than the Group A. It also shows that after using the Tutorial Mode, both groups achieved higher average scores. To investigate more, made a detailed comparison of FBD and moment equation average scores of both groups (Figure 4.3 and 4.4).

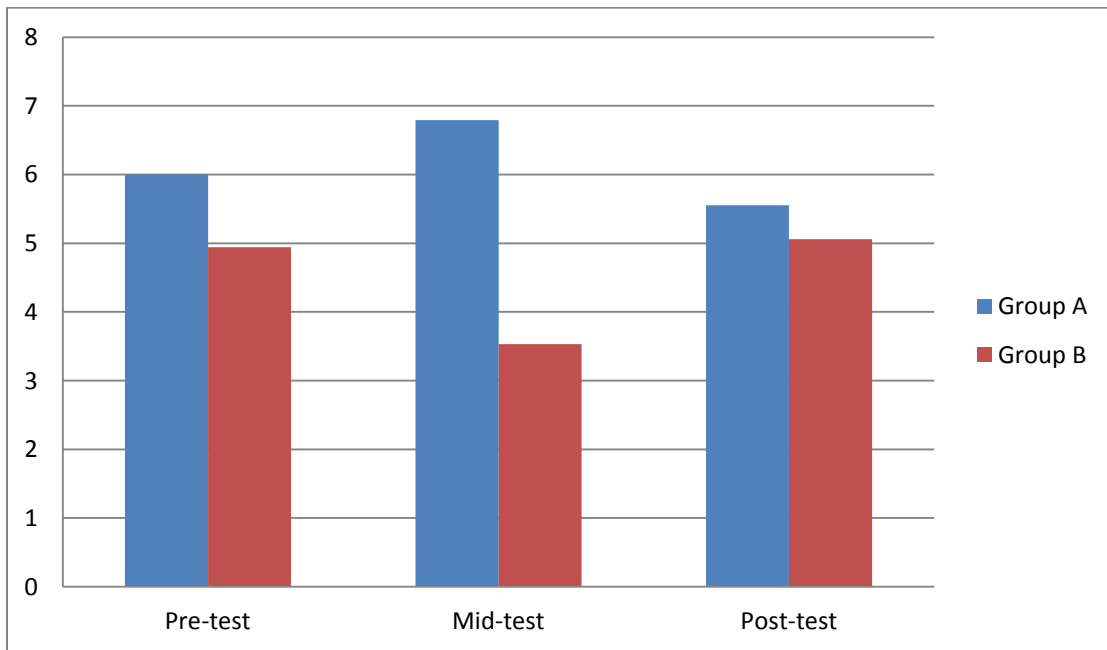

Figure 4.3: Comparison of FBD scores in tests for both groups.

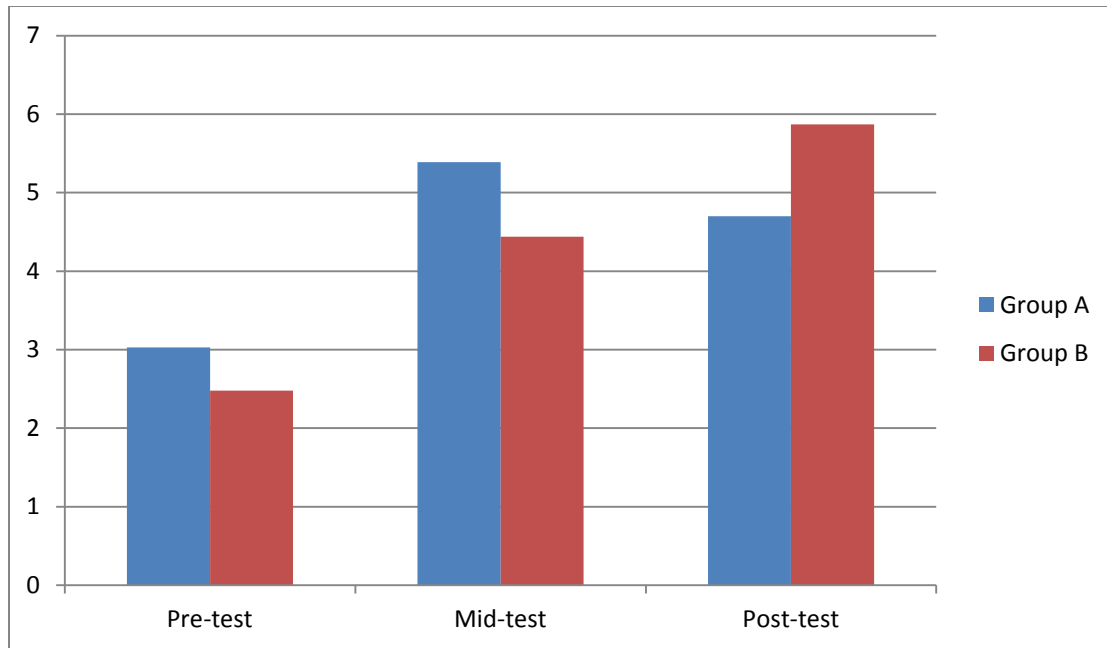

Figure 4.4: Comparison of Moment equation scores in tests for both groups.

In these charts, we could see that after using the tutorial mode, both groups gained higher scores on the FBD and moment equation. Both FBD scores also dropped after using book mode. For the moment equation, the average score in group A had a similar trend as mentioned, while the score of group B increased after both assignments.

We also take a look at the pie charts (Figure 4.5 to 4.10) specifying the errors that the students made during construction of moment equation, since having the moment equation is the most crucial step when solving this single-body Statics problem.

Group A

Pre-test:

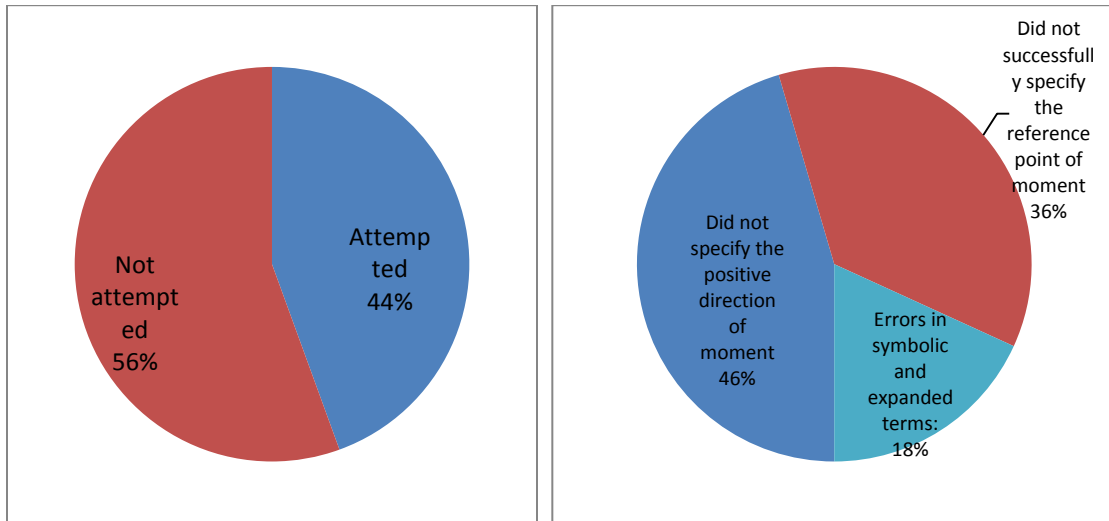

Figure 4.5: Percentage of students in Group A attempted constructing moment equation and the corresponding errors during Pre-test.

Mid-test (After Tutorial Mode):

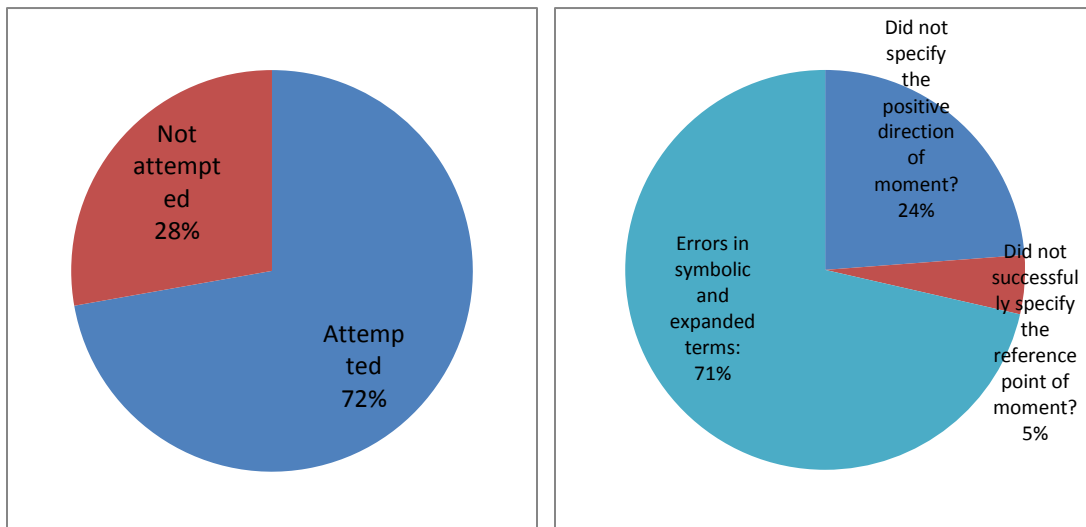

Figure 4.6: Percentage of students in Group A attempted constructing moment equation and the corresponding errors during Mid-test.

Post-test (After Book Mode):

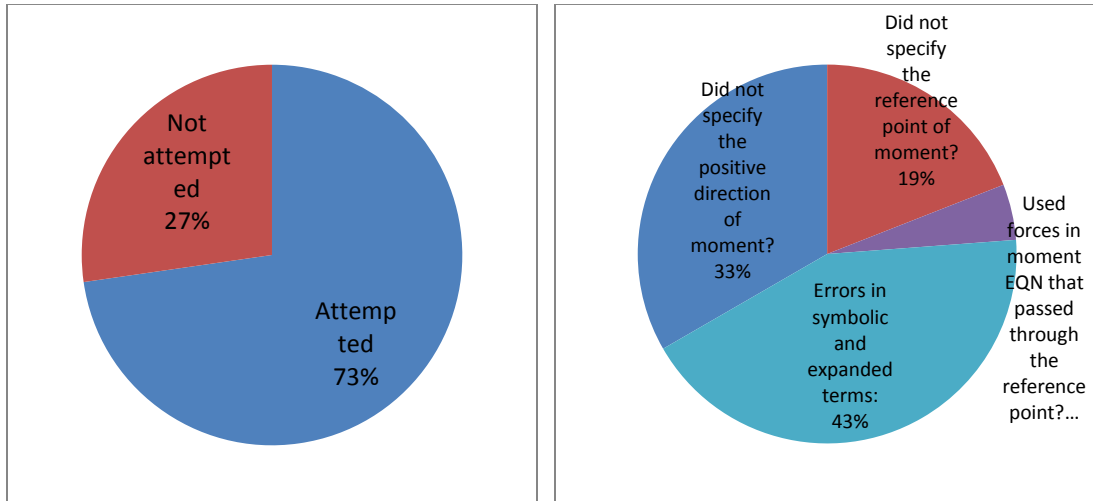

Figure 4.7: Percentage of students in Group A attempted constructing moment equation and the corresponding errors during Post-test.

The percentage of students in group A who had attempted moment equation jumped from 44% to 72% after using Tutorial Mode, showing a sharp increase. The percentage of errors made in symbolic and expanded terms also increased from 46% to 71%, which could be explained due to the fact that more students had tried to construct moment equation and advanced into steps that solve for unknowns.

Group B

Pre-test:

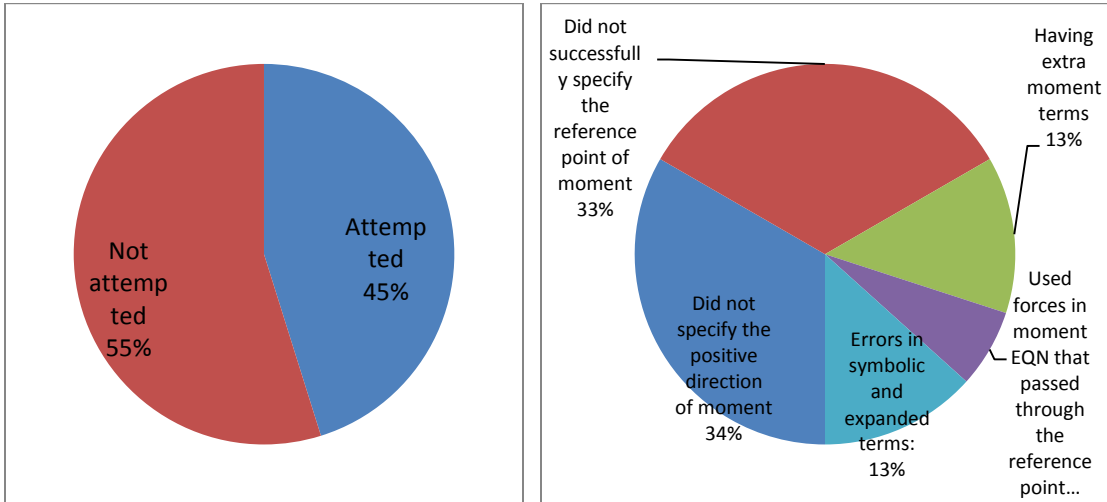

Figure 4.8: Percentage of students in Group B attempted constructing moment equation and the corresponding errors during Pre-test.

Mid-test (After Book Mode):

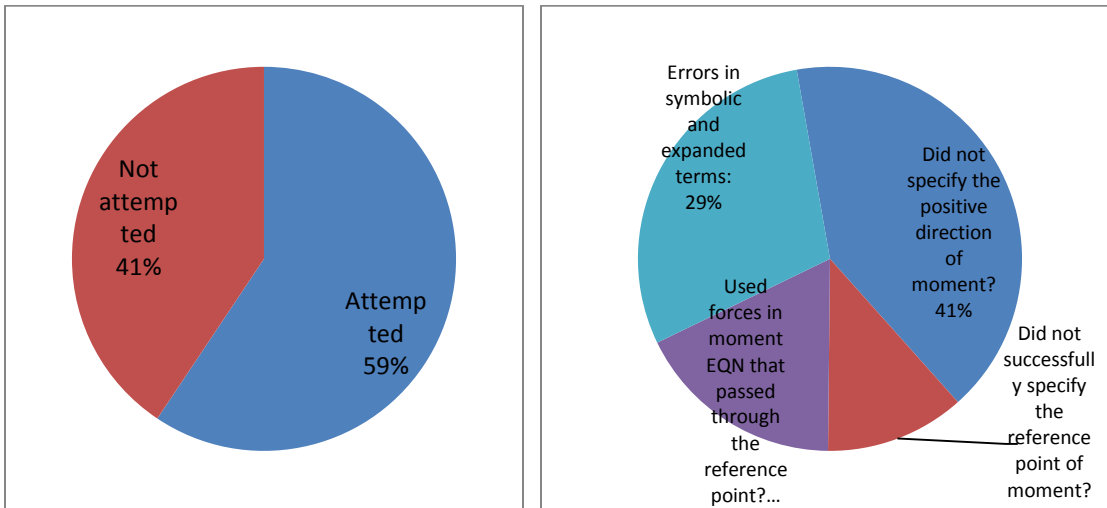

Figure 4.9: Percentage of students in Group B attempted constructing moment equation and the corresponding errors during Mid-test.

Post-test (After Tutorial Mode):

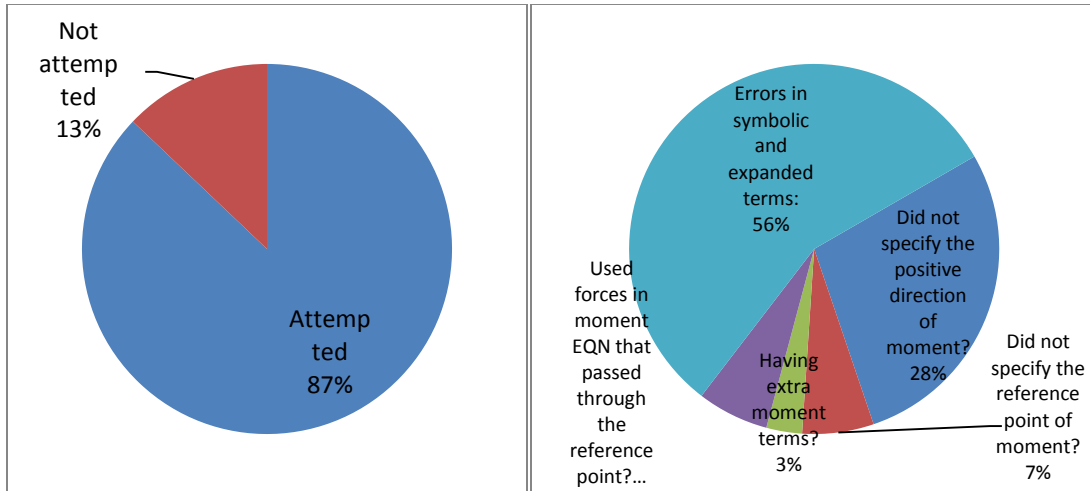

Figure 4.10: Percentage of students in Group B attempted constructing moment equation and the corresponding errors during Post-test.

Here we can see that the percentage of students in group B who had attempted the moment equation also increased from 59% to 87% after using Tutorial Mode, showing a difference of 28 percentage points. While the increase after using Book Mode was only 14 percentage points. This is a good indication that Tutorial Mode is more helpful than Book Mode.

We then look into the grades of assignment. During phase one, 40 students had used Tutorial Mode while 37 used Book Mode; after the switch, there were 37 and 33 students for each mode, respectively (Figure 4.11). We also excluded the students who had logged in to the system but did not attempt anything after firing up the problem.

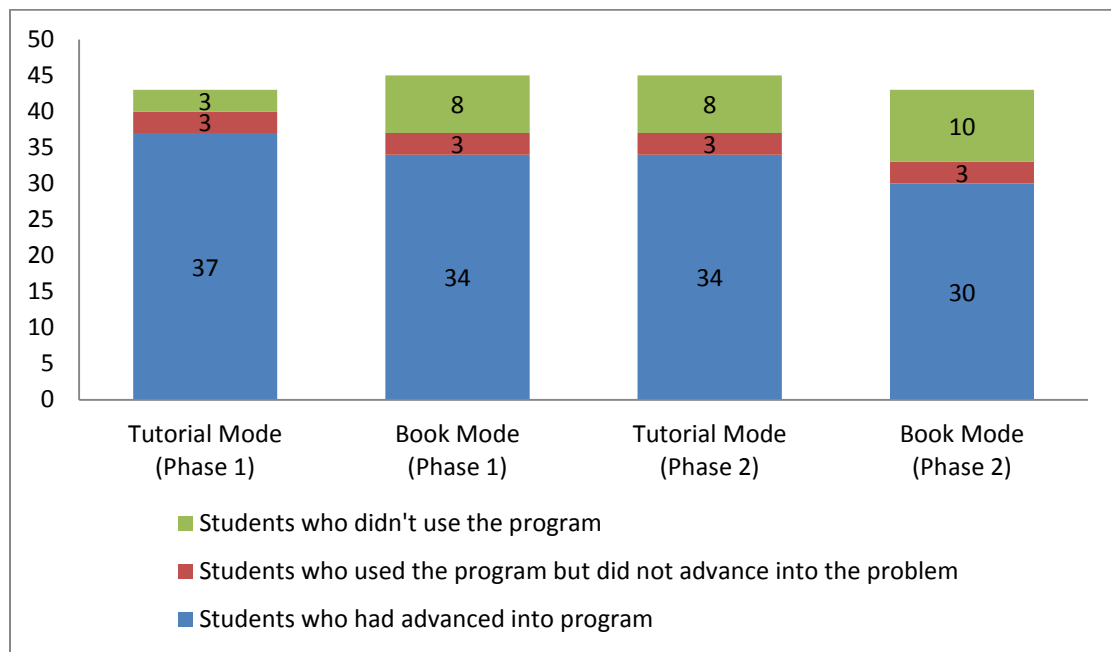

Figure 4.11: Actual usage of Newton's Tablet.

The results were classified under FBD, X, Y, and moment equation for all three problems (Figure 4.12 to 4.15). Since we had assigned a value of 1 for the completion of each component, the result can also serve as the fraction of students completing each specific step correctly.

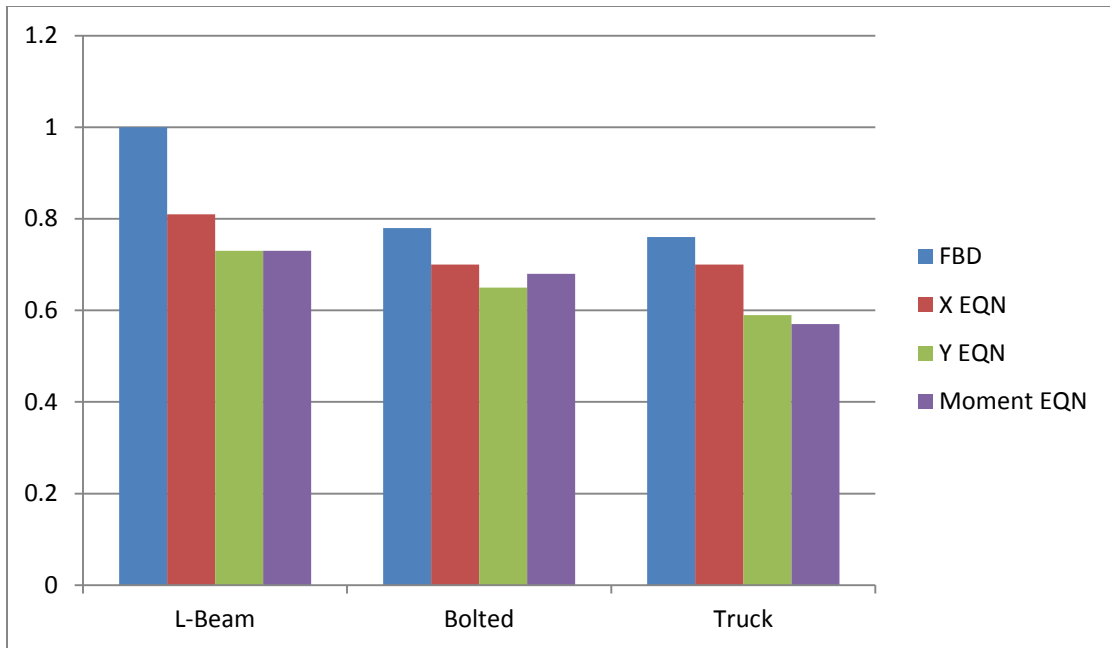

Figure 4.12: Fraction of students in Group A completing each step correctly during Tutorial Mode.

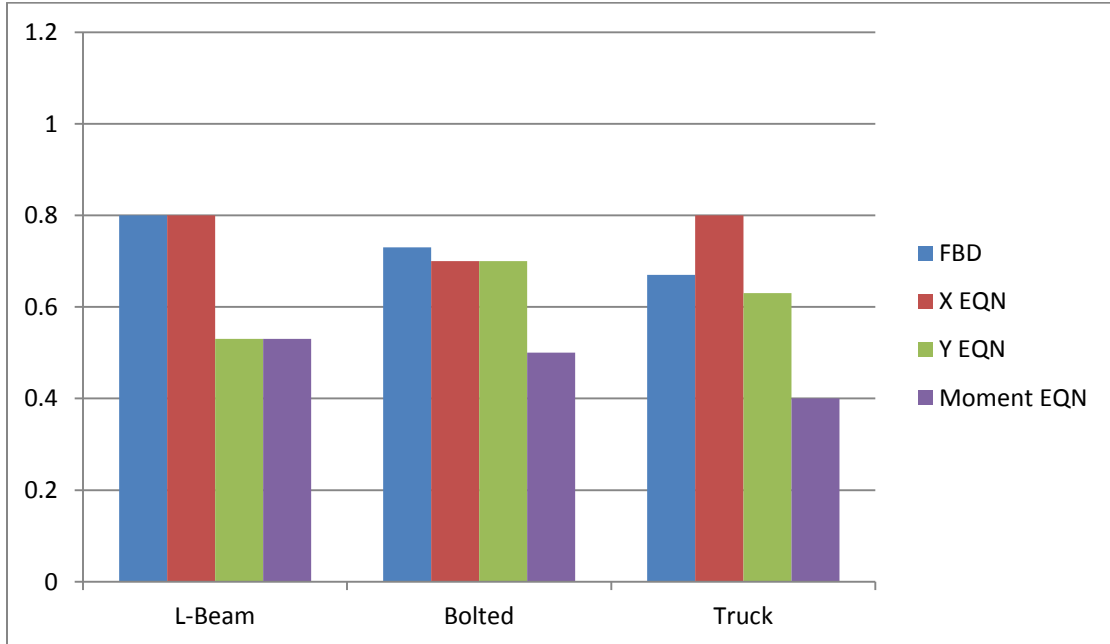

Figure 4.13: Fraction of students in Group A completing each step correctly during Book Mode.

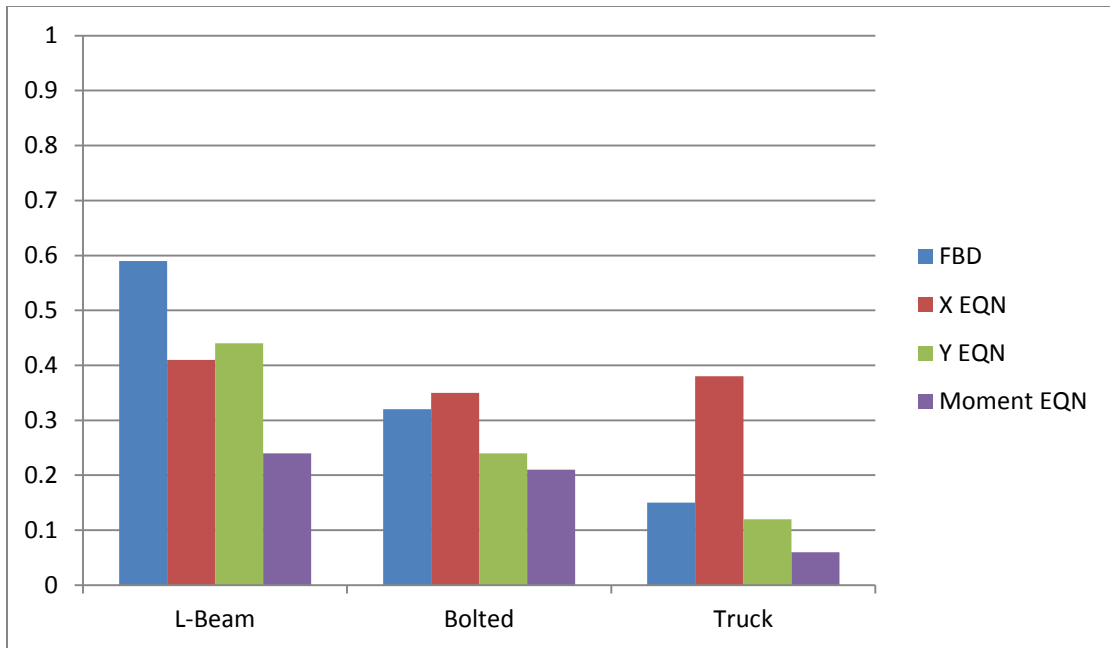

Figure 4.14: Fraction of students in Group B completing each step correctly during Book Mode.

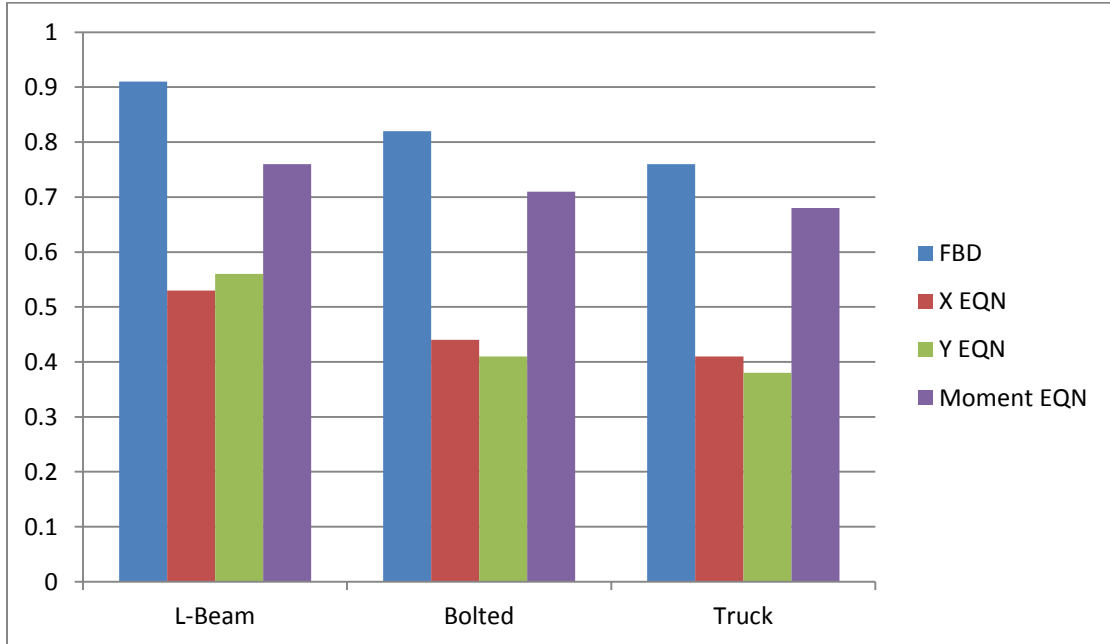

Figure 4.15: Fraction of students in Group B completing each step correctly during Tutorial Mode.

In general, both groups achieved better assignment grades under the Tutorial Mode than using Book Mode, which can be expected since the Tutorial Mode provides instant feedback to students when they made a mistake. At this point, combining the results from the three tests and the assignment, we are confident that Newton's Tablet provides a positive impact to students' learning.

Last but not the least, after having all results, we would like to find the correlation between the scores achieved in the assignment when students were using Tutorial Mode, and the scores obtained in the tests afterward. For this task, we use the popular data mining software, Weka. As for the training data, we excluded the students who did not take the test, nor do we include students who did not finish the assignments. The results are shown in Table 4.1 and 4.2.

```

FinalTotal =
  -9.8278 * L_BEAM_X +
 -11.8662 * BOLTED_FBD +
  10.322  * BOLTED_X +
  17.0018 * BOLTED_Y +
 -6.1265 * BOLTED_Moment +
 -9.8111 * TRUCK_Y +
   9.9361 * TRUCK_Moment +
  16.4967

Time taken to build model: 0.03 seconds

==== Cross-validation ====

==== Summary ====

Correlation coefficient          0.4051
Mean absolute error              5.7989
Root mean squared error          7.533
Relative absolute error          101.4693 %
Root relative squared error      110.5964 %
Total Number of Instances       34

```

Table 4.1: Correlation for Group A students after using Tutorial Mode.

```

FinalTotal =
   6.9295 * L_BEAM_X +
 -11.8654 * L_BEAM_Y +
   7.5641 * BOLTED_Y +
   4.1538 * TRUCK_Moment +
   8.1474

Time taken to build model: 0.03 seconds

==== Cross-validation ====

==== Summary ====

Correlation coefficient          0.467
Mean absolute error              5.1917
Root mean squared error          5.765
Relative absolute error          96.3221 %
Root relative squared error      91.1012 %
Total Number of Instances       29

```

Table 4.2: Correlation for Group B students after using Tutorial Mode.

Chapter 5

Study 2: Design and Evaluation of Effectiveness of a Multimedia Scaffolding Technique

Having evaluated the effectiveness of Newton's Tablet, we wanted to know further that after extending the current system by providing an additional multimedia scaffolding technique, whether using multimedia medium to convey educational tutorial would affect the learning performance of students. Hence, we came up with the idea of adding a complete set of Statics tutorial animation that goes alongside with Newton's Tablet and comparing the performance of students using such system with that of students having access to the same set of content, but in traditional paper-based material only.

To do so, we designed the animation videos to correspond to each individual stage that the user will encounter in Newton's Tablet, so the user's interaction with the program can be intertwined with one part of the whole video set. This way, the user only needs to focus on *one* specific topic each round, sparing the burden of having to complete watching all the tutorial videos before going into the program.

For the software, we use Adobe Flash CS5 and Microsoft PowerPoint to draw the animation. Adobe Flash is proficient at manipulating vector graphics, making it easier to make adjustment to the size of the video image without losing the resolution. PowerPoint, on the other hand, provides a quick and clean interface for us to add narrations to separate frames. For description-intensive animations such as the ones explaining the construction

of force and moment equilibrium equation, PowerPoint actually serves as a better tool than Flash.

Design and Content

We started drawing the sketch of the animation around mid-June in 2014 and spent five months revising the content to make it informative and accurate. The base for the animations is an example Statics problem that we slightly modified from the L-Beam problem provided in Newton's Tablet (Figure 5.1). Instead of an applied force on the upper-right corner, we use a cable holding a weight to pull the beam. Also, the roller is in a new location now.

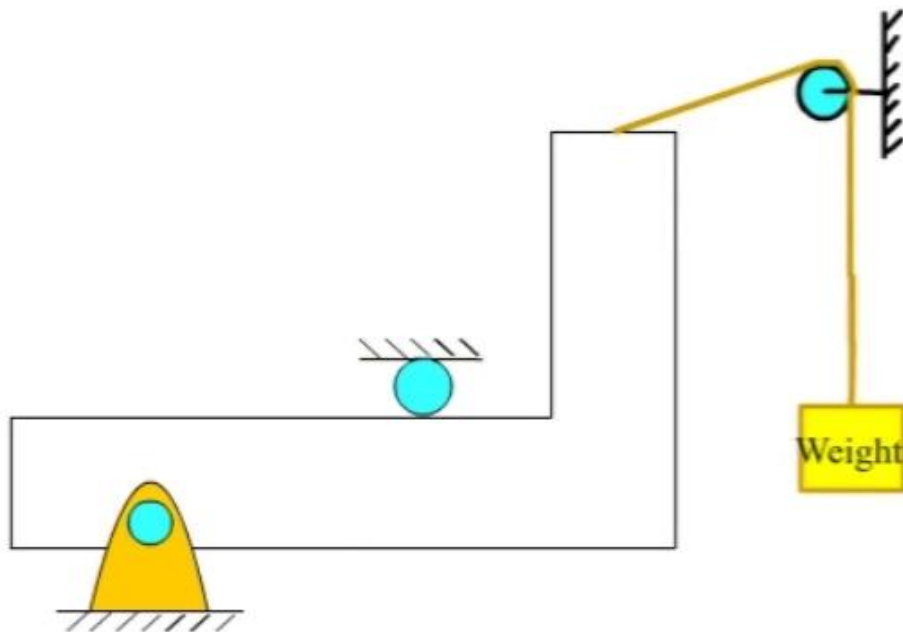

Figure 5.1: The modified L-Beam problem.

The variation was intentionally added to provoke the viewers into actually following the Statics concepts instead of simply copying all the actions that they saw on the animation. We also had test run of the problem with students to make sure that the variation between the problem in the animation and the program would not cause significant confusion. The content of each animation is briefly described as follows:

Correct Boundary:

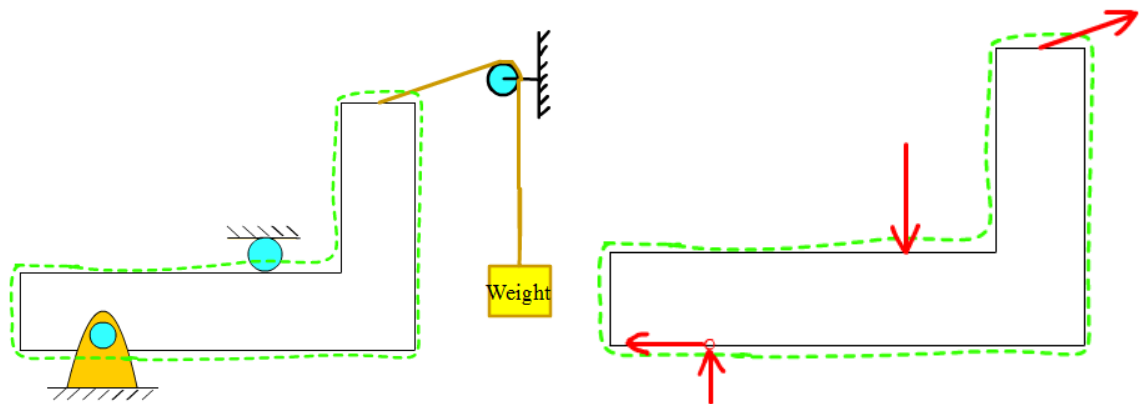

Figure 5.2: Representing the problem with boundary and corresponding forces.

To solve a single-body Statics problem, the first step is constructing a free body diagram. As such, the boundary of the object in question should be first identified. We start with providing the correct boundary to learners, as well as represent all interactions between external supports and the object as forces. Then we go into the common errors that would be made in the next two videos.

Gravity:

Although gravity is not taken into account in this particular problem, we introduce this universal force that acts across the boundary. Gravity applies force to all particles that comprise the system, producing a system of parallel forces. (Figure 5.3)

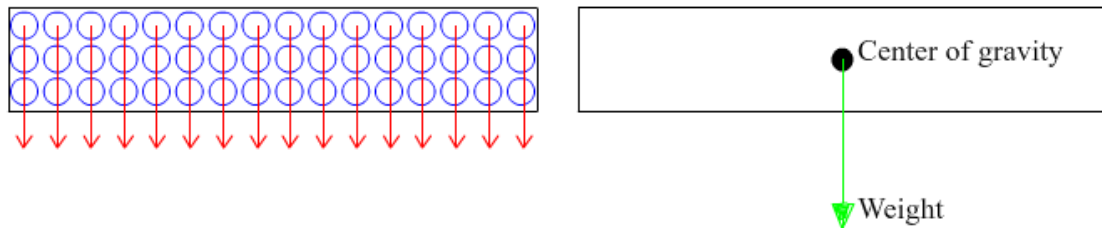

Figure 5.3: Illustration of summarizing all microscopic force acting on an object into one force on a specific point.

We hence represent this system of weight forces as one resultant force acting at the center of gravity of the object.

Incorrect Boundary:

For beginners, it is common for them to account for interactions within the boundary that are actually internal forces to the system. Since internal forces have no net effect on the system, they should not appear on the free body diagram. We assume that we have a spring inside the structure and show that the reaction forces cancel the interactions (Figure 5.4).

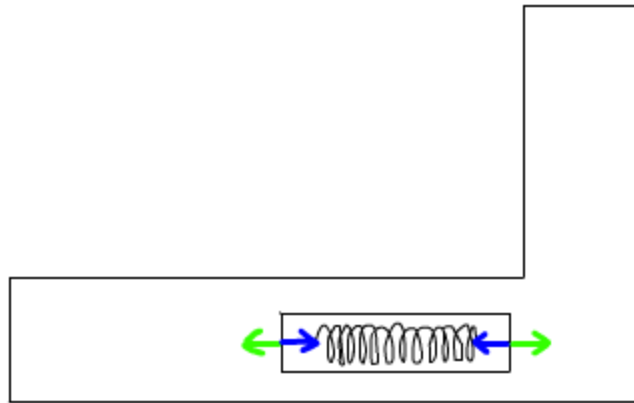

Figure 5.4: Illustration for explanation of internal force.

We then show the difference between selecting the right boundary and erroneously including external supports (Figure 5.5). For example, when we exclude the pivot at the lower-left corner, we clearly see that the pivot only provide two force components to the system. Nevertheless, when we accidentally include the pivot inside the boundary, we would have an extra moment reaction to consider. We point out this error because it is commonly occurred among students who are new to the subject.

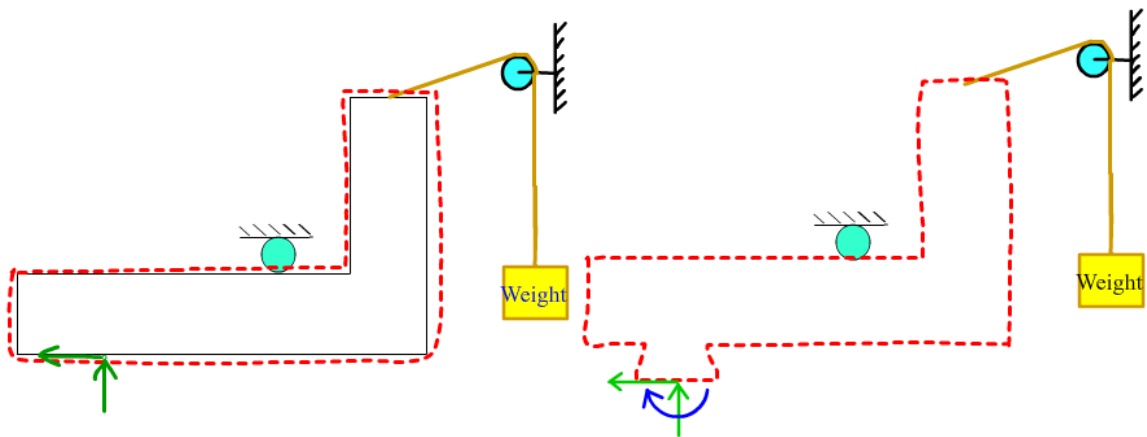

Figure 5.5: Difference between the two boundaries.

Locating Point of Interaction:

After the user finishes the boundary tracing, the next phase would be requiring them to locate the points of interaction on the object to represent all interactions with external supports (Figure 5.6).

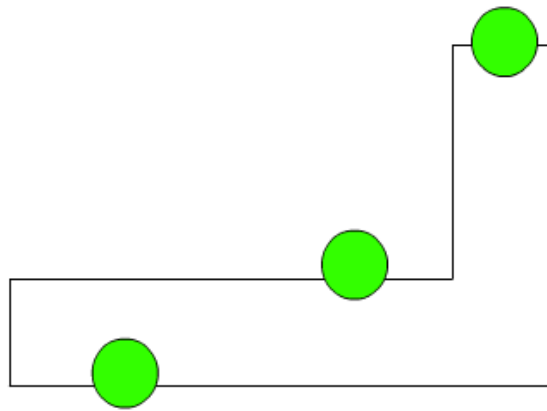

Figure 5.6: Representing external supports as points of interaction.

Classifying Point of Interaction:

Once we have located the points of interaction, the next step is to specify the types of interactions that occur (Figure 5.7).

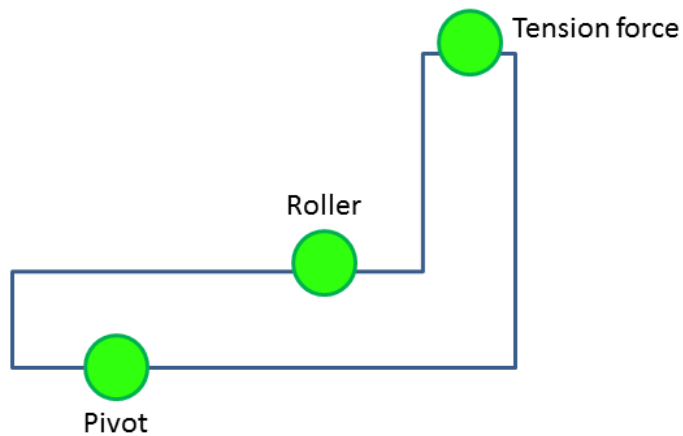

Figure 5.7: Classification of points of interaction on the L-beam.

Drawing Forces (for Points of Interaction):

This animation is supplemental to the previous one in part that this explains in detail how different types of POIs affect the number and direction of forces that would appear with associated types. We start with the introduction of pivot and roller joint (Figure 5.8 and 5.9).

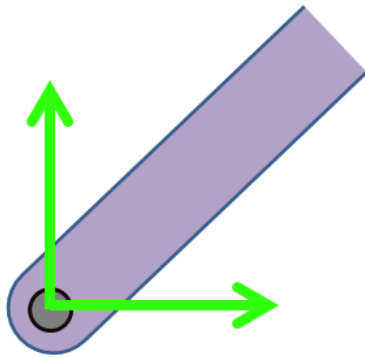

Figure 5.8: Forces acting on a pivot.

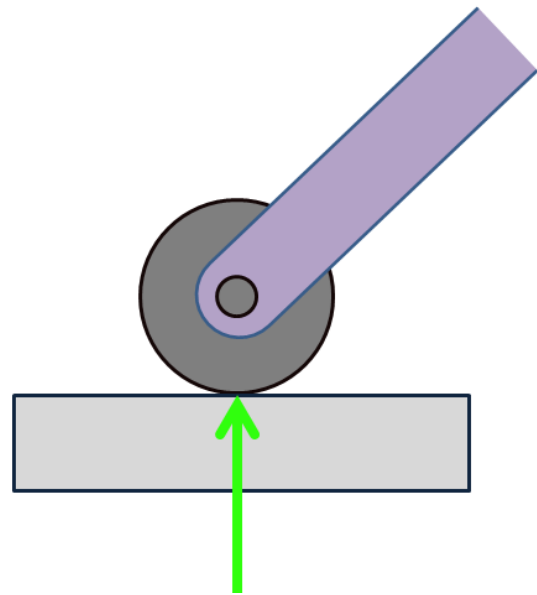

Figure 5.9: Forces acting on a roller.

We then proceed to flexible elements. While a cable can only provide tension force (Figure 5.10), springs can provide tension and compression depending on the configuration (Figure 5.11).

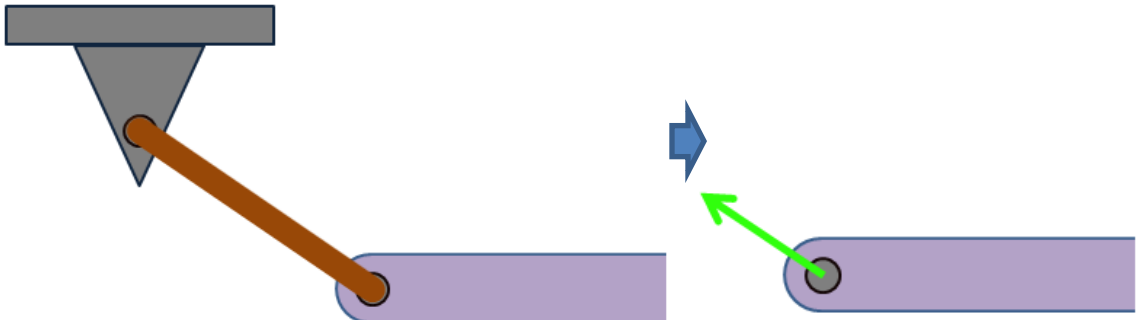

Figure 5.10: Cable.

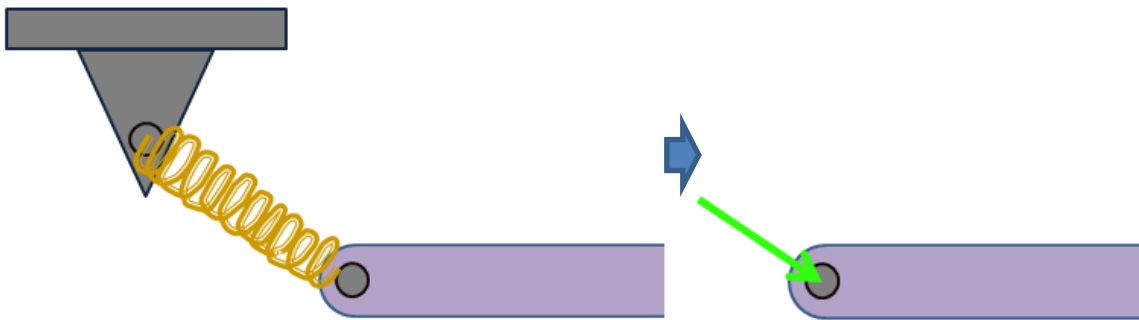

Figure 5.11(a): Spring under compression, pushing the object.

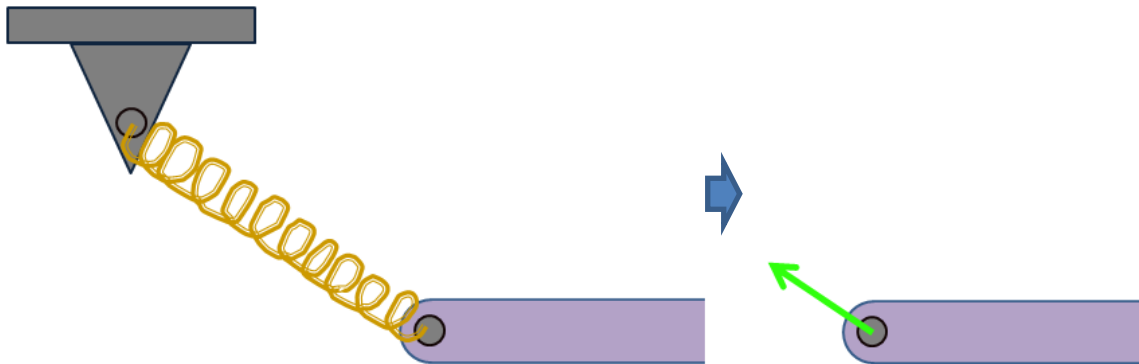

Figure 5.11(b): Spring under tension, pulling the object.

As for situation where the problem provides the parameter without specifying the type, we simply refer to it as the applied force (Figure 5.12).



Figure 5.12: Applied force.

Finally, we represent the original problem with the force associated with corresponding types of points of interaction (Figure 5.13). We also point to the student that the initial direction for the force does not affect the validity of solution. If we have pointed the force in the opposite direction, we would simply get a negative term.

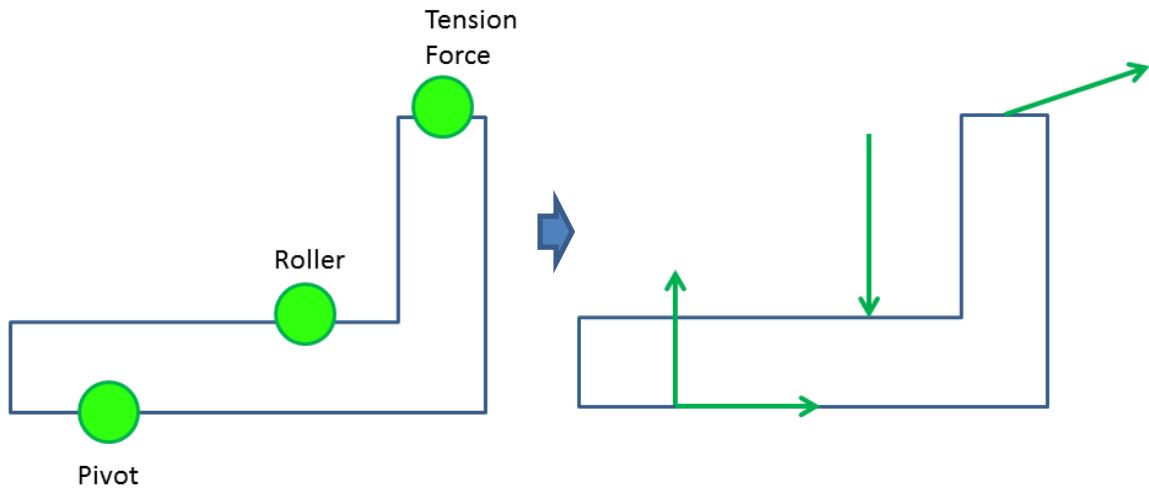

Figure 5.13: Representing the original POIs with force distribution.

Constructing Force Equation:

For the force equation, we start with the construction of equilibrium equation in X component (Figure 5.14). We guide students to identify each force that has a component in the X direction. The color scheme for the arrow would change from blue to green and

red so we can later use these two colors to represent forces that have X components, and those who does not (Figure 5.15).

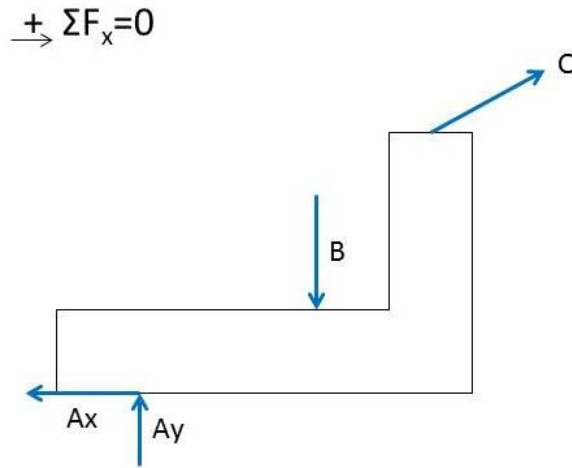

Figure 5.14: Free body diagram for the L-Beam problem.

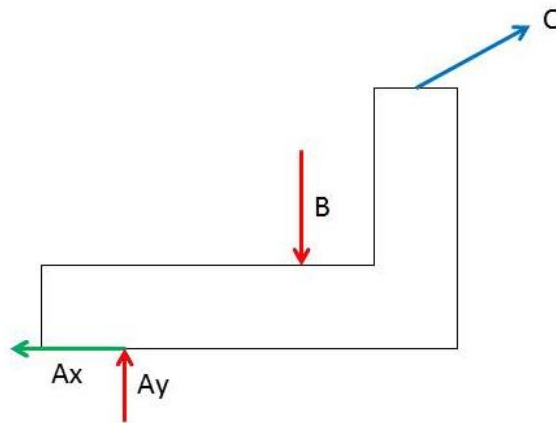

Figure 5.15: Using different color code to show whether individual force has component in X direction.

Emphasis is also given at the point where it is necessary for the students to break down the forces for further analysis (Figure 5.16).

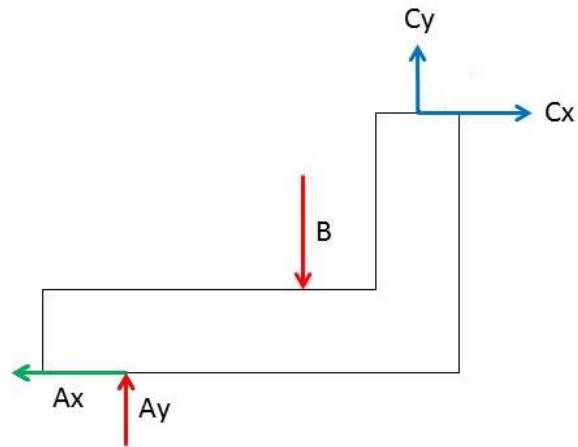

Figure 5.16: Decomposing force C into components C_x and C_y .

Constructing Moment Equation:

Introduction to the concept of moment is the most important one in the video set, since it involves the crucial steps of solving for the unknowns in these problems. We begin by mentioning the reference point for the moment as well as setting the positive direction. To strengthen their understanding for the direction for moment rotation, we intertwined appearing and fading bars to mimic the action of an object rotating about a given point (Figure 5.17 and Figure 5.18).

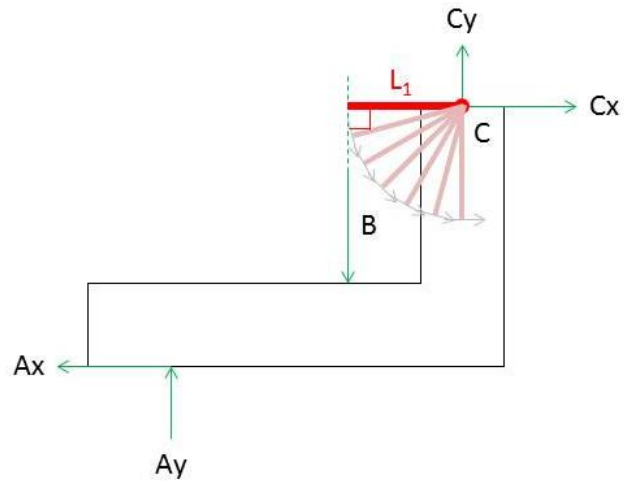

Figure 5.17: Showing the moment arm L_1 for Force B . Please note that we are showing swinging arm action for a clearer and more straight-forward representation.

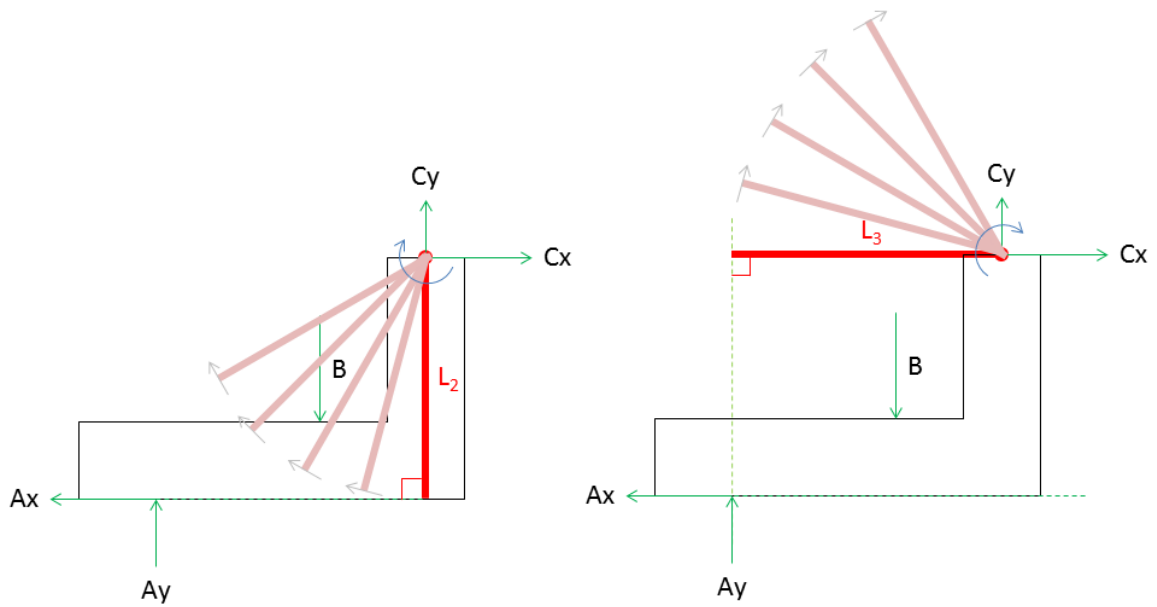

Figure 5.18: (Left) The moment arm for A_x is L_2 . A_x tends to cause clockwise rotation about C. (Right) The moment arm for A_y is L_3 . A_y also tends to cause clockwise rotation about C.

We then gradually show the effects of selecting different points in the problem as the reference point for the moment equilibrium equation. This particular video posed a lot more challenges than previous ones. Here we not only have to show the Statics concepts, but we also want to express such concepts with animations that could not be easily conceived with PowerPoint. For example, when we are trying to bring animation to the rotating arm action, it requires 24 animation events for a single swing.

Chapter 6

Study 2: Experimental Design

Tools to use

For the experiment, we would use the latest version of Newton's Tablet with animation playback feature. (Figure 6.1a)

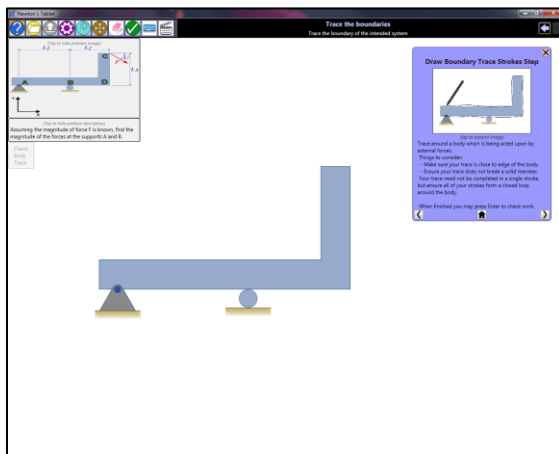

Figure 6.1(a): Normal working mode of Newton's Tablet.

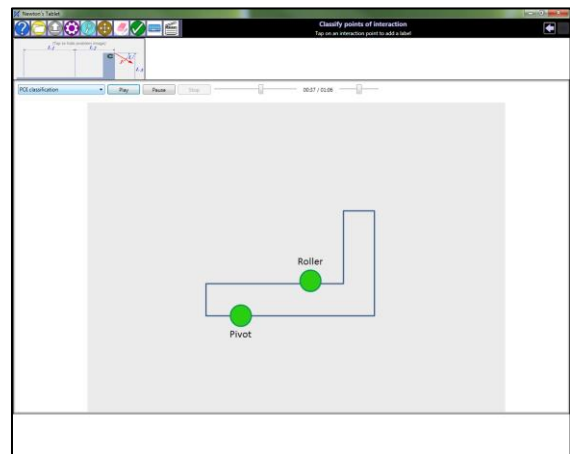

Figure 6.1(b): With animation sub-window shown.

As shown in Figure 6.1(b), to make sure that the student has in fact finished watching the animation before proceeding, the sub-window is set to block the working area of Newton's Tablet while playing the animation clips.

Participants

Since this would be a user study in smaller scale, approximately 10 to 20 students who had not taken Statics would be required to participate in the experiment. We

specifically aimed for students who had taken ME2, for they would have the knowledge sufficient enough to start but leave space for improvement, striking the perfect balance.

Experiment Procedure

We first split the students into *control group* and *experimental group*. As before, we evaluate the performance of students by giving both groups the pre-test before they proceed to solve the same single-body Statics problem.

For the experimental group, the students are provided with the latest version of Newton's Tablet, which is added with video playback feature to show tutorial animation during different phase of Statics problem solving.

The program starts with boundary tracing of the single body. To teach the student the definition of a boundary and the possible error he or she might make along the way, we show three animations to explain how to isolate a system from unnecessary interactions, including the effects of gravity on Statics problem. After the boundary is successfully drawn, we show "POI_selection" to help the student locate all point of interactions on the body, followed by "POI_classification" to correctly classify different kinds of POIs. To strengthen the concepts of different types of points of interaction, we have "Force_Drawing" to show the characteristics of different POIs, and the corresponding force types. Finally, after the free body diagram is completed, we use another two animations to guide the students on how to construct the necessary equations to solve for the unknowns. The step-by-step procedure for experimental group is presented in the Table 6.1 in a top-down manner.

Problem and Phase	Animation to play
Starting problem: L-Beam	
Boundary tracing	L_Beam_Correct_boundary.wmv
	L_Beam_Gravity.wmv
	L_Beam_Incorrect_boundary.wmv
POI selection	L_Beam_POI_selection.wmv
POI classification	L_Beam_POI_classification.wmv
Force drawing	L_Beam_Force_Drawing.wmv
Equation entry for force	L_Beam_force_equation.wmv
Equation entry for moment	L_Beam_moment_equation.wmv
End of problem: L-Beam	

Table 6.1: The list of videos played at different stages of the program.

After the corresponding videos are played, we would also have an instruction video played at the end to show how to perform those steps in the program.

For students in the control group, a same set of material is provided with the major difference from the experimental group that the entire material for control group will be presented through a collection of carefully edited handout printed on paper. All narrations in the animation will instead be shown in text on the handout.

Both groups would be instructed to finish the three problems in Newton's Tablet. After both groups have completed the assignments, we give them a post-test using the exact same problem appeared in pre-test and compare the scores that the students achieved.

Problem for Pre- and Post-Test

To avoid having participating students from ME2 during spring 2014 encounter the identical test problem, this time we slightly modified the problem that we used before by changing the angle of configuration, and asked the students to solve for the tension force in the cable. We also change the parameter for the weight hanging at the rod (Figure 6.2).

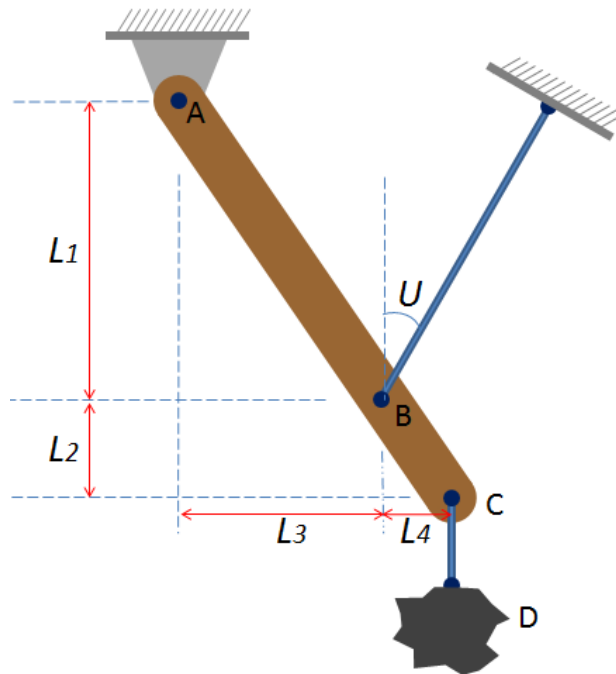

Figure 6.2: Problem image for the pre- and post-test.

Duration of Experiment

To finish the pre-test, the three problems on Newton's Tablet, and the post-test would take approximately 1.5 to 2 hours for each participant.

Grading for Pre- and Post-test

The pre- and post-test were then graded according to the rubric in Table 6.2. FBD has a total score of 50 while equation part has a total of 100. Here, the student earns each part of the points for correctly completing them, but loses points for having extra forces in FBD or extra terms in moment equation.

FBD

1. Boundary (+10 points)
2. Ax (+10 points)
3. Ay (+10 points)
4. Cable (+5 points)
 - a. Model as known direction (+5 points)
5. Weight (+10 points)
6. Number of extra forces (-10 points)

Moment Equation

1. Prototype (+5 points)
2. Sign convention (+5 points)
3. Tension X component term
 - a. Moment arm (+10 points)
 - b. Sign (+10 points)
 - c. Model as known direction (+5 points)
 - d. Having correct component (+5 points)
4. Tension Y component term
 - a. Moment arm (+10 points)
 - b. Sign (+10 points)
 - c. Model as known direction (+5 points)
 - d. Having correct component (+5 points)
5. Weight term

- a. Moment arm (+10 points)
 - b. Sign (+10 points)
 - c. Including g (+5 points)
 - d. Including mass (+5 points)
6. Number of extra terms (-30 points)

Table 6.2: Grading rubric for FBD and moment equation for pre- and post-test.

For students who had used moment equation as well as X and Y force equations, we have a separate set of rubric in Table 6.3, in which different amount of points are assigned to different criteria, but still maintain the same total score.

Moment Equation

1. Prototype (+2 points)
2. Sign convention (+2 points)
3. Pivot X component term
 - a. Moment arm (+6 points)
 - b. Sign (+6 points)
4. Pivot Y component term
 - a. Moment arm (+6 points)
 - b. Sign (+6 points)
5. Weight term
 - a. Moment arm (+3 points)
 - b. Sign (+3 points)
 - c. Including g (+3 points)
 - d. Including mass (+3 points)
 - e. Number of extra terms (-12 points)

Force Equation

1. X component
 - a. Prototype (+5 points)
 - b. Sign convention (+5 points)
 - c. Pivot X component (+2.5 points)
 - i. Sign (+2.5 points)
 - d. Tension X component
 - i. Trigonometry (+2.5 points)
 - ii. Sign (+2.5 points)
 - e. Number of extra terms (-5 points)
2. Y component
 - a. Prototype (+6 points)
 - b. Sign convention (+5 points)
 - c. Pivot Y component (+1.5 points)
 - i. Sign (+1.5 points)
 - d. Tension Y component
 - i. Trigonometry (+1.5 points)
 - ii. Sign (+1.5 points)
 - e. Weight
 - i. Sign (+1 points)
 - ii. Including g (+1 points)
 - iii. Including mass (+1 points)
 - f. Number of extra terms (-3 points)

Attempted to solve for solution (+10 points)

Correctly solved for solution (+10 points)

Table 6.3: Rubrics for grading multiple equations.

Chapter 7

Study 2: Results

The experiment was conducted from 2014/11/17 to 12/8. Announcement was sent to the roster of ME002 in spring and made during ME018 in fall 2014. Eventually, a total of 15 students had participated. The distribution of participants between both groups is listed in Table 7.1 and 7.2.

	Experimental Group	Control Group
Undergraduates	6	3
Master's students	2	1
PhD students	2	1

Table 7.1: Number of students participated.

Major	Experimental Group	Control Group
Mechanical Engineering	5	2
Chemistry	1	0
Neuroscience	1	0
Computer Science or Engineering	3	1
Plant Pathology	0	1
Cell Molecular and Development Biology	0	1

Table 7.2: Distribution of participants according to different majors.

Although this experiment was primarily targeting undergraduates from mechanical

engineering who had not taken Statics, we were only able to secure 7 students from ME department. For the rest of the group, 1 undergraduate from chemistry, 1 PhD student from neuroscience, 1 PhD and 3 master’s student from computer science or engineering, 1 PhD from plant pathology, and 1 undergraduate from cell molecular and development biology had participated. All students had taken introductory physics or equivalent courses; no student had previously taken Statics.

We begin by looking at whether the students had obtained the correct answer for the pre- and post-test. (Figure 7.1)

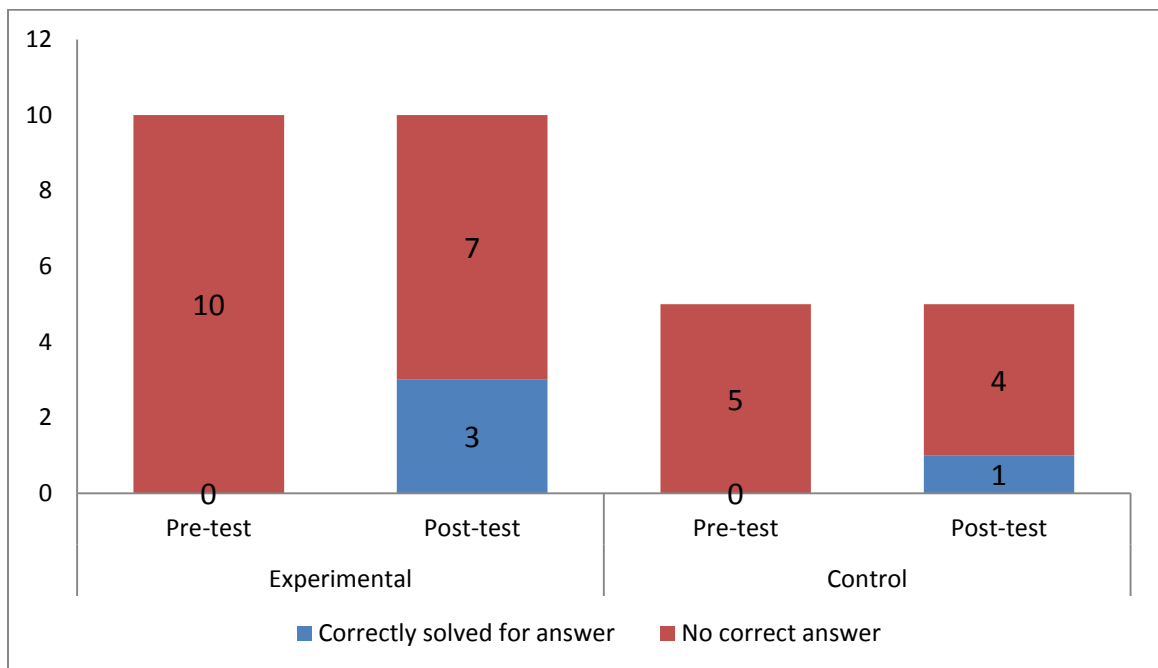

Figure 7.1: Comparison of test score for both group between pre- and post-test.

For the experimental group, no student was able to obtain the correct solution during the pre-test, while 30% of students were able to correctly solve for the unknown in the post-test. For the control group, no student was able to obtain the correct solution during

pre-test either. In the post-test, only 20% of them were able to correctly construct the solution to the problem.

Nevertheless, there were frequent cases where students were not able to correctly solve for the answer due to minor algebra error, but were conceptually correct. We are concerned as whether the student had received the concepts from the tutorial. To investigate further, we take a closer look at the total score they achieved. The equation scores for experimental group are shown in Figure 7.2. Out of 10 participants in experimental group, only 3 had achieved partial scores for attempting to construct fragments of equations, delivering an average score of 10.65. After using the scaffolding system, the average score jumps to 77.65, showing a sharp increase.

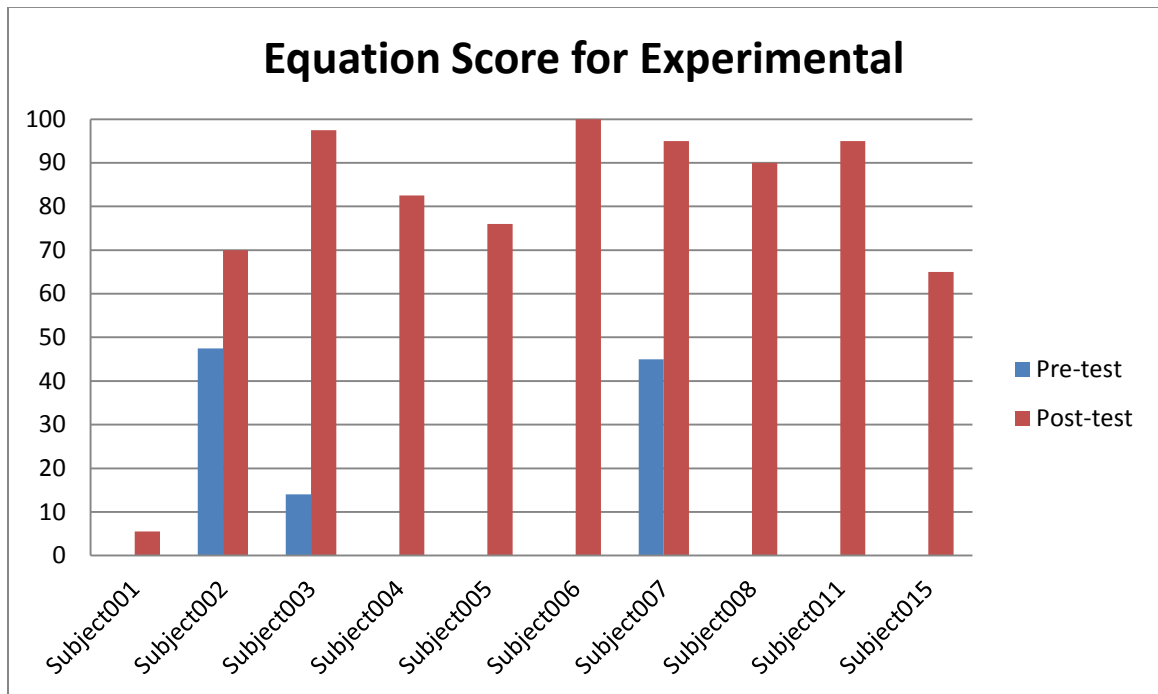

Figure 7.2: Comparison of equations scores in pre- and post-test for the experimental group.

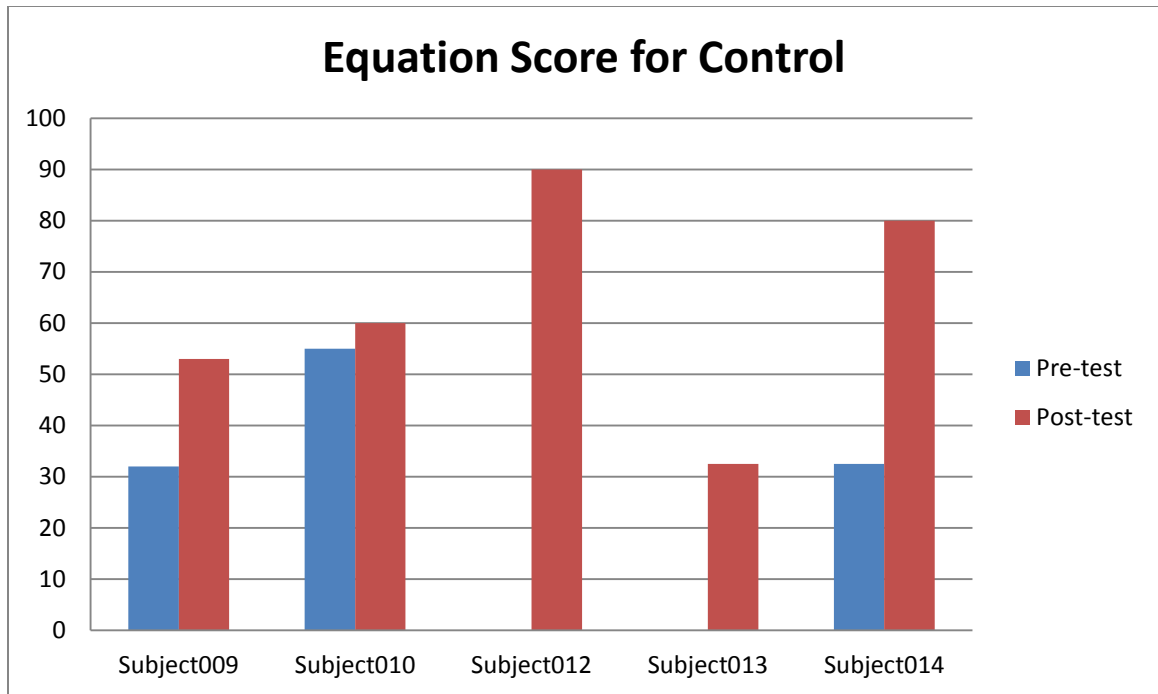

Figure 7.3: Comparison of equations scores in pre- and post-test for the control group.

As for control group, 3 out of 5 students were able to write some parts of equations during pre-test, nevertheless did not show huge improvement overall after receiving the tutorial. While subject 12 went from zero score to 100, no participant in the rest of the group had showed improvement more than 50 points (Figure 7.3). In fact, the average score for post-test of control group only gained 39.2 from the original 23.9.

We also look at the strategy that they used to solve for the problem. For the test problem, only one moment equation is necessary to solve for the unknown if we select the pivot joint as the reference point. The students could also select reference point about the cable attachment or the weight-hanging point, and combine the X and Y force equilibrium equations to solve for the unknowns. These strategies, although not all efficient, could show that the students had certain degree of understanding for Statics

equilibrium problem and deliver the correct result.

During the pre-test, only 20% of the students were able to construct enough equations to solve for the unknown in experimental group, while 60% for control group. Although all students in both groups were able to deliver enough equations in the post-test, the experimental group showed a much larger percentage increase than the control group. (Figure 7.4)

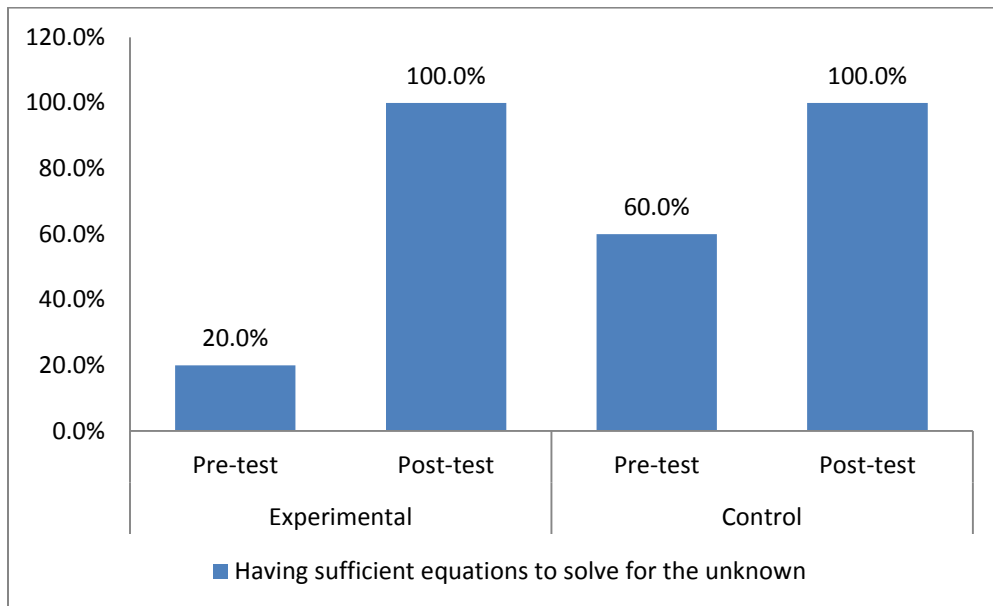

Figure 7.4: Percentage of students successfully constructed sufficient equations to solve the problem.

After students had obtained the equations, we then look at whether the students had attempted to derive the equations to solve for the forces (Figure 7.5). During the pre-test, both groups had a 40% of attempt rate, while in the post-test all participants in the experimental group attempted to derive the equations, larger to the 80% from the control group.

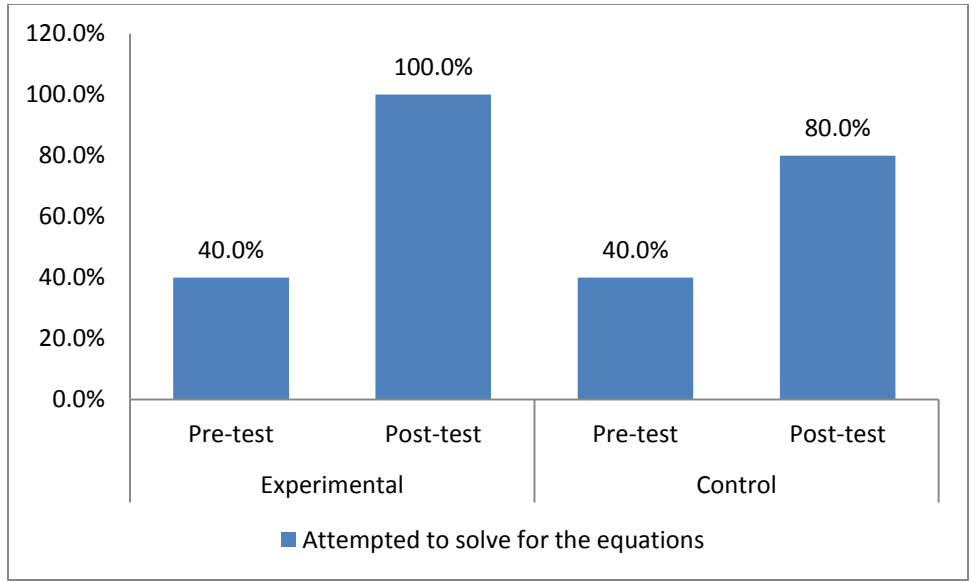

Figure 7.5: Percentage of students who attempted solving the problem.

We also look at the grades of construction for the free body diagram (Figure 7.6 and 7.7).

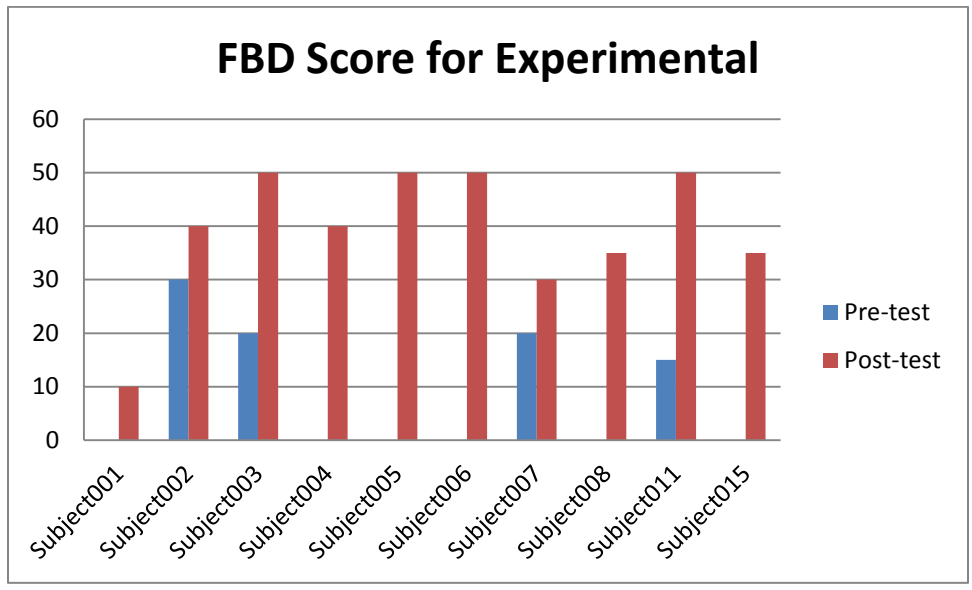

Figure 7.6: Grades of FBD for experimental group.

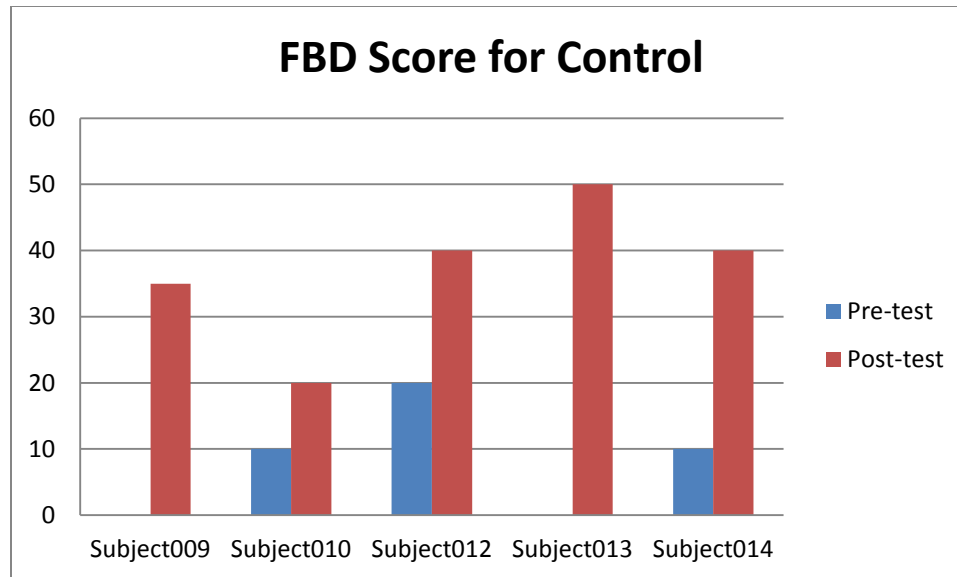

Figure 7.7: Grades of FBD for control group.

Since we did not explicitly ask the students to construct one, most students did not try this step during the pre-test. Therefore, we focus on the percentage of correctness out of the number of students who had attempted to construct one. As we can see, both groups of participants were not able to deliver the correct FBD during pre-test, while 50% of participants from experimental group succeeded drawing a correct FBD in the post-test, higher than the 40% of that from control group. (Figure 7.8)

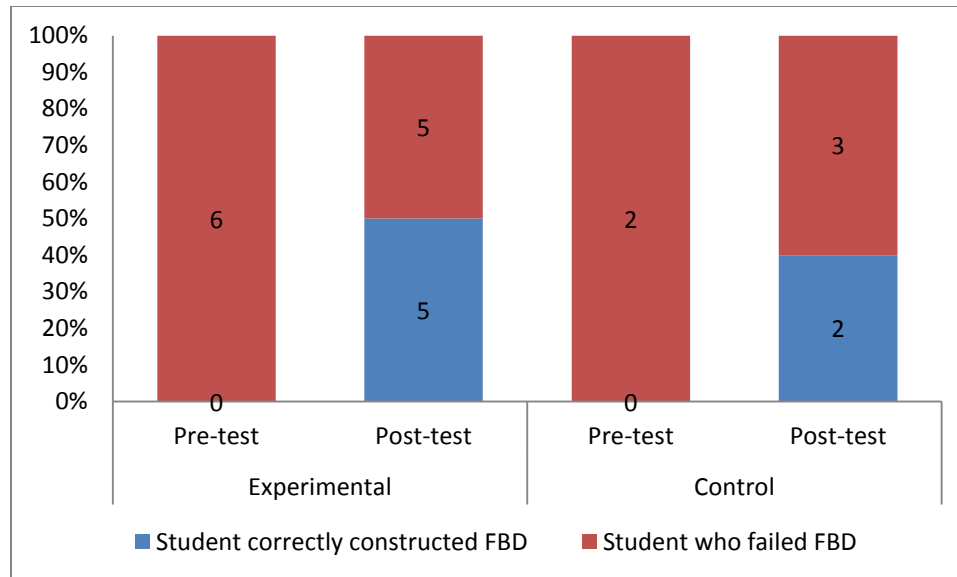

Figure 7.8: Percentage of students who successfully completed FBD among all who tried.

Finally, we went through the detail of test sheets and made certain inference regarding whether the errors that the student made were by incorrect concept or by accident. In the example test sheets in Figure 7.9 and 7.10, we could see evidently that the students had made a mistake when they were trying to break down the tension force with the angle U . Since U is the angle between the cable and vertical axis, the horizontal force component should be " $T \cdot \sin U$ " and vertical force component " $T \cdot \cos U$ ". Several participants had incorrectly obtained the force components and built equations accordingly, which gave them erroneous result. By excluding such trigonometry and algebra error, the participant was very likely to correctly solve the problem.

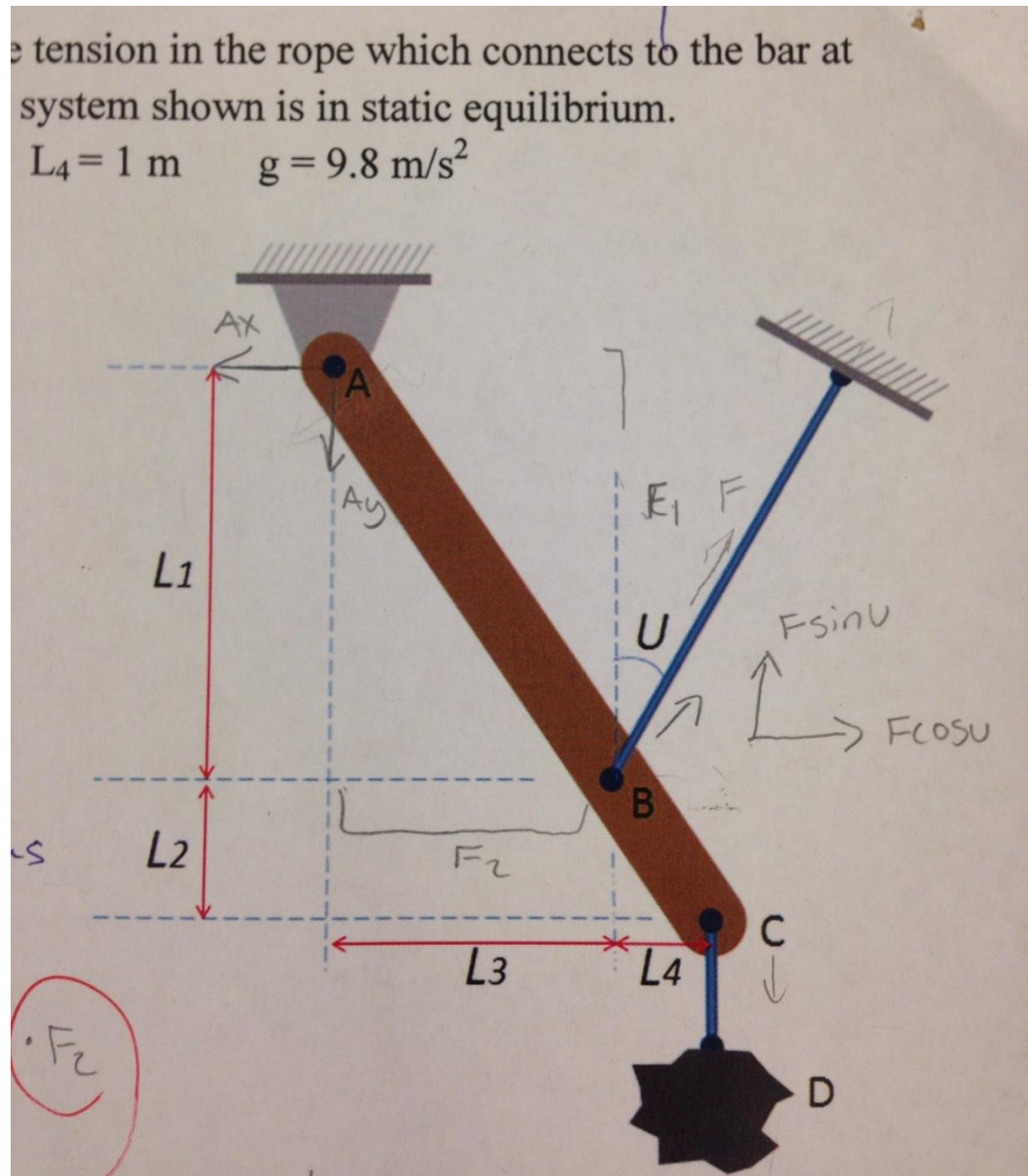

Figure 7.9: Example of test sheet from participants.

of rock D is 50 kg, what is the magnitude of the tension in the rope which connects to the bar at B. Assume that the bar itself is massless and that the system shown is in static equilibrium.

$L_1 = 6 \text{ m}$ $L_2 = 2 \text{ m}$ $L_3 = 3 \text{ m}$ $L_4 = 1 \text{ m}$ $g = 9.8 \text{ m/s}^2$

$3P_y = 490$

Free-body diagram of the bar AB:

- At A: Reaction forces P_x (horizontal) and P_y (vertical).
- At B: Tension force T at angle U .
- At C: Reaction forces T_x (horizontal) and T_y (vertical).
- Weight Mg acting downwards from the center of mass.

Equilibrium equations:

$$+\circlearrowleft \sum M_B = 0$$

$$= -M_1(g) + M_2(P_x) + M_3(P_y)$$

$$= -(L_4)(F_g) + (L_1)(P_x) + (L_3)(P_y)$$

$$= -1\text{m}(50 \cdot 9.8) + (6)P_x + 3(P_y) = 0$$

Force balance equations:

$$\sum F_x = 0$$

$$= -P_x + T_x = 0$$

$$= -P_x + T \cos U$$

$$\boxed{T \cos U = P_x}$$

$$\sum F_y = 0$$

$$= -P_y - F_g + T_y$$

$$= -P_y - F_g + T \sin U$$

$$= -P_y - (50)(9.8) + T \sin U$$

Handwritten notes:

is conceptually
e but made
~~coming from~~
panding symbolic term.
 $-P_x + T \cos U$

Figure 7.10: Example of test sheet from participant.

We therefore calculate another set of statistics that not only accounts for students who had the correct answer, but also students who showed having the correct Statics concepts and simply did not achieve the right result due to minor non-Statics errors.

(Figure 7.11)

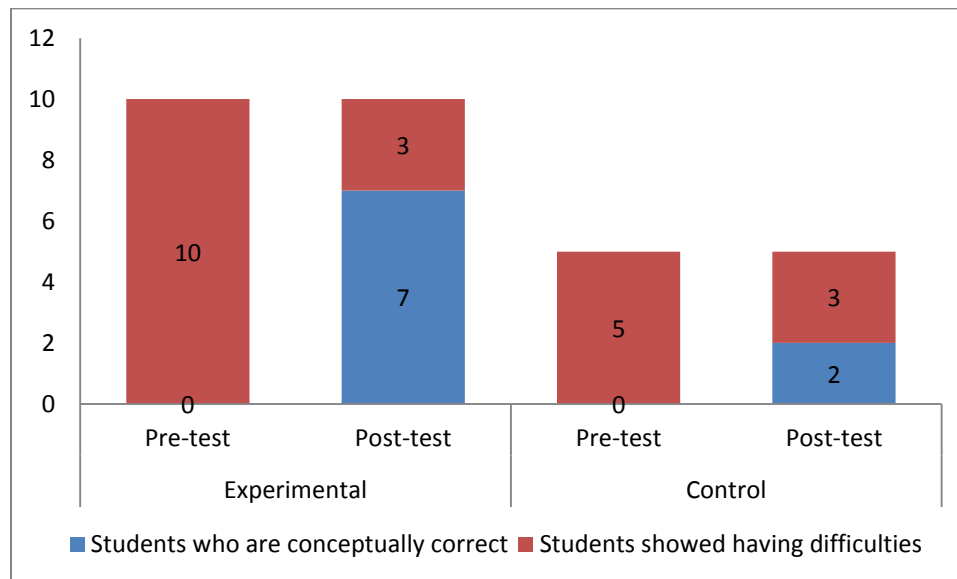

Figure 7.11: Percentage of students in both groups who showed having the correct concept.

Here, we show that as high as 70% of participants in experimental group had obtained the correct concepts after using the tutoring system with multimedia scaffolding, while 40% in control group had made the same progress with the traditional pen-based material.

Chapter 8

Conclusion

In this thesis we have confirmed that the tutoring system brings positive effects to the learning performance of students. By re-running the evaluation of Newton's Tablet on a class of 80 students, we obtained a more indicative result than previous attempt by providing two different operation modes in Newton's Tablet that delivered different levels of assistance to see the variance of learning gain among students.

We also discovered that by combining multimedia scaffolding teaching technique with a tutoring system, it served as a greater tool than traditional educational medium. Through the tutorial animation, we were able to show the essential Statics concepts that a student need to correctly solve for an equilibrium problem in fluent and accurate motion that paper-based material cannot possibly parallel.

Further evaluation of the scaffolding system would be possible if opportunities are granted to find more undergraduate students from the mechanical engineering. As much as we had promoted for the user study, we were only able to secure 15 participants from various background, therefore could not show much statistical significance in our final results. If the experiment could be tested in a larger scale that only limits the major and year of students, we are confident that the scaffolding can deliver better results.

Reference

- [1] Donald L. Bitzer, "Computer Assisted Education", in Special Issue: The New Science of Information in Education, Volume 12, Issue 3, 1973.
- [2] National Center for Education Statistics
(<http://nces.ed.gov/fastfacts/display.asp?id=46>)
- [3] Intelligent Tutoring System
(http://en.wikipedia.org/wiki/Intelligent_tutoring_system)
- [4] Brusilovsky, P., Schwarz, E., & Weber, G. (1996), "ELM-ART: An intelligent tutoring system on World Wide Web." In Frasson, C., Gauthier, G., & Lesgold, A. (Ed.), Intelligent Tutoring Systems (Lecture Notes in Computer Science, Vol. 1086). Berlin: Springer Verlag. 261-269.
(<http://www.contrib.andrew.cmu.edu/~plb/ITS96.html>)
- [5] Evens et al, "CIRCSIM-Tutor: An Intelligent Tutoring System using Natural Language Dialogue", in ANLC '97 Proceedings of the 5th conference on Applied natural language processing: Descriptions of system demonstrations and videos.
- [6] Arthur C. Graesser et al, "AutoTutor: An Intelligent Tutoring System With Mixed-Initiative Dialogue", in IEEE Transactions on Education, Vol. 48, No. 4, November 2005
(<http://ieeexplore.ieee.org/stamp/stamp.jsp?tp=&arnumber=1532370>)
- [7] Reyna Garcia, "Intelligent Statics Tutoring Systems as Tools for Undergraduate Mechanical Engineering Education", March 2014.