

Lawrence Berkeley National Laboratory

Recent Work

Title

RESULTS FROM SOME ANODE WIRE AGING TESTS

Permalink

<https://escholarship.org/uc/item/27j5v9vq>

Authors

Juricic, I.
Kadyk, J.A.

Publication Date

1986

c.2



Lawrence Berkeley Laboratory

UNIVERSITY OF CALIFORNIA

RECEIVED
LAWRENCE
BERKELEY LABORATORY

Physics Division

JUL 17 1986

LIBRARY AND
DOCUMENTS SECTION

Presented at the Workshop on Radiation Damage to
Wire Chambers, Berkeley, CA, January 16-17, 1986

RESULTS FROM SOME ANODE WIRE AGING TESTS

I. Juricic and J.A. Kadyk

January 1986



LBL-21691

c.2

DISCLAIMER

This document was prepared as an account of work sponsored by the United States Government. While this document is believed to contain correct information, neither the United States Government nor any agency thereof, nor the Regents of the University of California, nor any of their employees, makes any warranty, express or implied, or assumes any legal responsibility for the accuracy, completeness, or usefulness of any information, apparatus, product, or process disclosed, or represents that its use would not infringe privately owned rights. Reference herein to any specific commercial product, process, or service by its trade name, trademark, manufacturer, or otherwise, does not necessarily constitute or imply its endorsement, recommendation, or favoring by the United States Government or any agency thereof, or the Regents of the University of California. The views and opinions of authors expressed herein do not necessarily state or reflect those of the United States Government or any agency thereof or the Regents of the University of California.

RESULTS FROM SOME ANODE WIRE AGING TESTS*

Ivanna Juricic and John A. Kadyk
Lawrence Berkeley Laboratory
University of California
Berkeley, California 94720

ABSTRACT

Using twin setups to test anode wire aging in small gas avalanche tubes, a variety of different gas mixtures were tried and other parameters were varied to study their effects upon the gain drop, normalized to charge transfer: $-\frac{1}{Q} \frac{dI}{I}$. This was found to be quite sensitive to the purity of the gases, and also sensitive to the nominal gain and the gas flow rate. The wire surface material can also significantly affect the aging, as can additives, such as ethanol or water vapor. Certain gas mixtures have been found to be consistent with zero aging at the sensitivity level of this technique.

I. INTRODUCTION

Anode wire aging effects resulting in loss of gain and gain non-uniformities have been observed for many years.^[1] However, the widespread use of gas avalanche counters and chambers, with increasingly challenging requirements, has demanded a more concerted effort be made toward understanding and curing these problems. The present set of tests were begun in an attempt to quantify the gain loss for a particular device, a gas sampling calorimeter, and has broadened to explore the effects of a number of parameters which result in gain loss. The technique makes use of small aluminum tubes of the same type used for the calorimeter, and exposes the tubes to γ radiation from an Fe^{55} source through a thin window. The gain region explored is in the vicinity of the operating region of our calorimeter, but also extends to higher and lower values of gain, covering a range used by many wire chambers. A variety of gas mixtures have been tested, and anode wires of two different compositions have been used. Other parameters that have been investigated include gas flow rate and source intensity. The results are parameterized in terms of the fractional gain loss per coulomb of charge transfer. No attempts were made to study breakdown processes resulting in large currents being drawn, and this phenomenon only rarely happened during the tests. This is relatively easily understood since breakdown processes appear to be initiated by deposits on the cathode, which in the tube geometry are spread over large areas of the cathode, which has, moreover, a small electric field at the surface compared to wire chambers. A large variety of deposits have been found on the anode wires during these tests, but these haven't been analyzed chemically. There are two equivalent test setups, having twin sources, which could be used to run two tests simultaneously.

*This work was supported in part by the Department of Energy under contracts DE-AC03-76SF00098 and DE-AC03-76SF00515.

II. PROCEDURE AND SETUP

The experimental test device used is shown schematically in Fig. 1. Each test counter was used only for one test, and then saved for later photographs and other studies. The aluminum tubes were prepared using a multi-step chemical cleaning procedure, followed by a final alcohol (ethanol) rinse shortly (a few days) before use. The feed-through insulators were made of molded fiberglass-epoxy, and these fit tightly into the ends of the tubes. Small residual leaks were eliminated using RTV in the early tests, and Sicomet 40 ("wicking" viscosity) for later tests, after it was found that the RTV had some influence on the results for certain tests. At the same time, the nylon inlet and outlet tubes for gas flow were also changed to short copper tubes (there was no evidence of problems due to the nylon tubes, however). The 0.6 mC Fe^{55} source illuminated about 6 mm of wire through a window of 0.5 mil mylar sheet, aluminized on the side toward the wire (see Fig. 1). The gas seals made in this fashion were excellent in the later tests (using Sicomet), but also generally very good with the RTV, but with some detectable leaks occasionally.

The anode wires were crimped into stainless steel capillary tubes at each end under 150 g tension. The wires tested were all of 50 μm diameter, and were made either of gold-plated tungsten, or Stablohm 800 (75% Ni, 20% Cr, balance of Al and Cu, according to manufacture^[2]).

The plumbing systems consisted of all copper or glass tubing upstream of the test counter and a short (~ 1 m) section of tygon tubing to a bubbler on the exhaust side. All copper and glass tubing was cleaned with ethanol before installation. Part or all of the gas could optionally be diverted through a glass system designed to bubble the gas through a liquid at a controlled temperature. A sparging device was used to ensure complete saturation of the vapor at the preset temperature. The high voltage was supplied by a Bertan 1739P supply and monitored with a Hewlett-Packard model 3465B 4-1/2 digit VTVM. This power supply was stable to less than ~ 1 volt out of $\sim 2\text{-}4$ kV. The currents were monitored with electrometers (Keithley models 410 and 610B), with the tubes at ground potential. The HV was set so that the gain was approximately in the desired range, and the current was monitored over the duration of the test, which was generally about 1 week, but ranged from $\sim 3\text{-}15$ days. Corrections for temperature and pressure changes were made to determine the relative gain. This was done by deducing the dependence upon gas density from the fluctuations in barometric pressure over short periods of the test during which time the drop in gain due to aging was negligible or could be corrected out. Such short-term barometric changes were as large as 1.5%, allowing an accurate determination of $\alpha_p = -(dI/I)/(dp/p)$, where I is the observed current, and ρ is the gas density. The gas flow and voltage were kept constant during a given run, and the rate of gain drop per coulomb was determined from the corrected current readings.

A "standardized" set of conditions was established corresponding to a 400 nA current, and an estimated gain of about 2×10^4 .^[3] The standard gas flow was ~ 60 cm^3/min and the effective source strength reduced to about 0.25 mC by inserting a 0.001 inch aluminum absorber. The standard wire was gold-plated tungsten, and the standard gas mixture was 50% argon + 50% ethane. The goal for the integrated charge in a given test was at least 0.2 Coulombs. Tests were performed with variations on these standard conditions in order to determine the effects of the various parameters. To be more specific, the gain has been varied corresponding to currents between 90 nA

EXPERIMENT SETUP

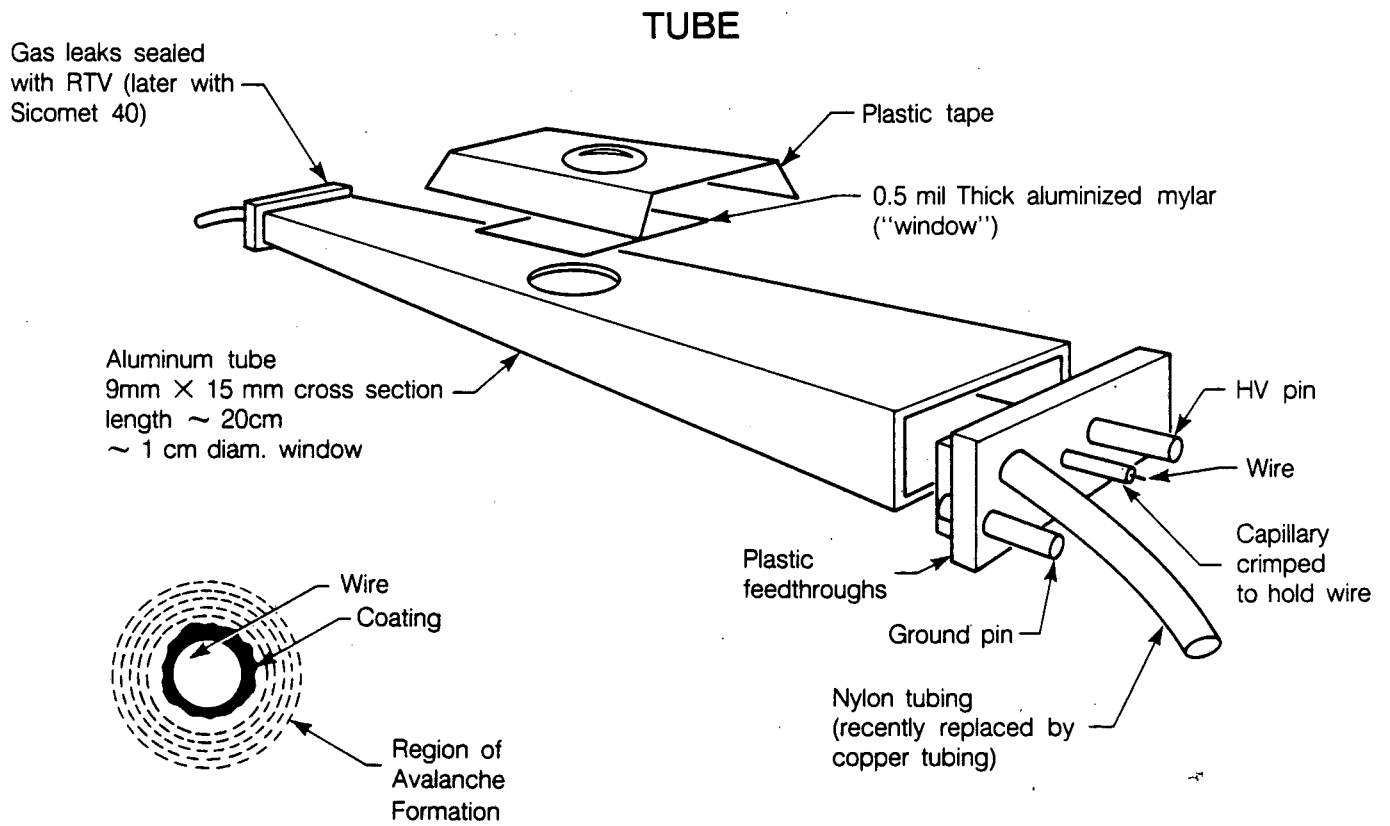

Fig. 1. Sketch of aluminum tube and fittings used for wire lifetime tests. A simple representation of wire, coating, and equipotential lines.

and 2 μA , the gas flow has been varied between about 12 and 380 cm^3/min , and the effective source strength between about 40 and 600 μCi . The principal tests have been made using five primary gas mixtures, plus a variety of additives intended to reduce the rate of wire aging.

III. DISCUSSION OF RESULTS

Table I contains the measurements of the rate of relative gain drop, $R = -\frac{1}{Q} \frac{\Delta I}{I}$ (%/Coulomb), for the various conditions shown. Results are listed according to initial current values, which are proportional to the initial gain. Some of the tests, however, were done with the full source strength, i.e., no absorber (denoted by the values enclosed in parentheses) or with a reduced effective source strength (using 0.003 inch aluminum absorber). For these tests, a comparison of gain can be made relative to tests done at "standard" source strength (0.001" Al absorber) by using the factor ≈ 0.4 for reduction in intensity of 5.9 keV γ -rays for each 0.001 inch of Al absorber. Since there is evidence that gas flow has a significant effect, the results are also grouped by flow rate. All results in Table I are corrected for gain variations due to ambient temperature and barometric pressure, and residual errors from these sources are negligible, as are voltage variations. The largest effects causing differences between otherwise similar tests are surmised to be due primarily to minor impurity differences in the gas. Some uncertainty could also be due to the stochastic nature of coatings on the wire. For certain of the tests, especially high purity gases were used (UHP argon, CP ethane, etc.) to test the effects of gas purity. These effects can be seen in several instances in this table (for gold-plated tungsten): (1) There are six tests listed for the "standard" condition (Ar/ethane), and it is noted that those with the higher purity gas and/or tubes sealed with Sicomet rather than RTV, give considerably lower values of R. (2) A similar conclusion is reached by comparing two other gases: (80% Ar + 20% CH_4) and (89% Ar + 10% CO_2 + 1% CH_4). In the former case, R is quite large (63) for the less pure gas, and consistent with zero for the purer gas (-6). In the latter case, there is about a factor of 10 between the values of R being very low for the purer gas (147 vs. 15). An intermediate value of $R = 36$ was also obtained with a different gas cylinder of lower purity specification, and this may have been simply a cylinder with fortuitously high purity. (3) Several tests with dimethyl ether clearly show the correlation between small amounts of freon 11 impurity, at the few parts per million level, and the gain drop rate, giving dramatic differences between results having apparently only these very small differences in purity. There are results shown from three different bottles of DME which have been analyzed using the gas chromatography/mass spectrometry technique.^[4] The most recent test was for a bottle having ≈ 1 ppm initially, and (14 ± 7) ppm at end of the test, due to concentration of freon 11 as the DME was used up. The 6-day long run was arbitrarily divided into two parts, and results shown are averages for these parts. The effect of concentrating the freon 11 is quite evident.

Another feature that is evident in Table I is the variation in R with current or "gain": when other conditions are fixed, the value of R decreases with increasing current. This same dependence has been noted by others.^[5] We see also a dependence on gas flow rate, which is explicitly shown in Table II. In three of the comparisons shown, there appears to be a quite significant increase in R for smaller flow rates. In the fourth gas listed, having a 1% H_2 additive, there appears to be a reversal of this rule,

Table I.

$$R = - \frac{1}{Q} \frac{\Delta I}{I} \text{ (%/Coulomb) for Principal Gas Mixtures}$$

(on ~0.6 cm wire length)

Notes and Symbols: () Used to denote non-standard source intensity (Zero shims, except d)

- a - "Purer" gas
 b - Sicomet seal
 c - RTV seal, Cu tubes on counter
 d - 3 shims (.001" Al absorber)
 e - Very low gas flow (12 cc/min)
 f - Tube breakdown after .007C
 g - "Pure" DME
 h - "10-20 ppm" CFCI₃
 i - ≤ 1 ppm CFCI₃, 1st half run
 j - ≤ 1 ppm CFCI₃, 2nd half run

□ Collection of runs all at
 400 nA initial current

○ Simultaneous runs

Gas	Wire/flow (\geq 100 cc/min)	Current (nA) (~gain)						
		2000	1000	700	400	200	100	60
50% Ar + 50% C ₂ H ₆	>100			(33)				
	Au/W <100	28		(69)	66.42 ^a 17 ^{ab} , 45 ^{ac} 28 ^{ab} , 6 ^b	99		(23) ^{bd}
	Stablohm >100 <100	-2	(79),(96)	(237)	130 336 ^{ab}			227
80% Ar + 20% CH ₄	Au/W <100				63 73 (6 ^{ab})			
	Stablohm >100 <100			96				
89% Ar + 10% CO ₂ + 1% CH ₄	Au/W >100 <100	16			36, 15 ^{ab} , 147 ^b	203		
	Stablohm >100 <100			55				
93% Ar + 4% CH ₄ + 3% CO ₂	Au/W <100				22 54 ^e			
	Stablohm >100		10		(26)			
Dimethyl Ether	Au/W 60 cc/min				(-12) ⁱ (11) ^g (108) ⁱ (732) ^h			
92% CO ₂ +8% iC ₄ H ₁₀	Au/W 60 cc/min				~1800 ^f			

Table II.
Effect of Gas Flow Rate on Gain Loss

Comparison of rate of gain drop vs. flow rate, with other conditions the same (gain, wire, gas):

$$R = \text{Gain Drop Rate} = - \frac{1}{Q} \frac{\Delta I}{I} \frac{\%}{\text{Coulomb}}$$

Shim refers to 0.001" Al absorber: ϕ (absent), 1 (present)

GAS	WIRE	HIGHER FLOW		LOWER FLOW	
50%Ar + 50% C ₂ H ₆	Au/W	105 $\frac{\text{CC}}{\text{min.}}$ ϕ Shim	R = 33 680 nA	50 $\frac{\text{CC}}{\text{min.}}$ ϕ Shim	R = 69 550 nA
50%Ar + 50% C ₂ H ₆	Stablohm	137 $\frac{\text{CC}}{\text{min.}}$ ϕ Shim	R = 90 750 nA	25 $\frac{\text{CC}}{\text{min.}}$ ϕ Shim	R = 237 680 nA
93%Ar + 4% CH ₄ + 3% CO ₂	Au/W	62 $\frac{\text{CC}}{\text{min.}}$ 1 Shim	R = 22 400 nA	13 $\frac{\text{CC}}{\text{min.}}$ 1 Shim	R = 54 300 nA
49.5% Ar + 49.5% C ₂ H ₆ + 1.0% H ₂	Stablohm	137 $\frac{\text{CC}}{\text{min.}}$ ϕ Shim	R = 96 810 nA	20 $\frac{\text{CC}}{\text{min.}}$ ϕ Shim	R = 70 765 nA

although in this case the difference is not so large, and may not be due solely to the effect of the gas flow (e.g., there may be an effect due to the H_2 additive).

As for the tests using Stablohm 800 wire, there appears to be a significantly higher value of R for Stablohm wire than for Au/W. This difference becomes much larger when ethanol or water vapor is used, as can be seen in Table III. However, for other gases there is not such strong evidence for higher R values with Stablohm, though there are not many results on this point.

Table III is concerned only with the effect of certain additives to the standard gas, 50% Ar + 50% ethane. Certain features seem to be rather clear in comparison to corresponding values of R for the standard gas without additives, as given in Table I. As observed by others, the effect of adding a low level (~ 0.5 -1.5%) of ethanol vapor appears to reduce dramatically the value of R in the case of Au/W wire, and within the precision of these tests perhaps even to zero for 1.5% ethanol. However, the effect of ethanol seems to have the reverse effect in the instance of Stablohm wire, as can be seen from the several results in Table III. Comparison with Table I shows that even without additives, Stablohm seems to have higher values of R with Ar/ethane, but this value is dramatically increased with the addition of ethanol. M. Atac, FNAL, has recently obtained evidence confirming this effect, based upon tests showing rapid degradation of pulse height resolution under similar conditions.^[6] Observation of the affected wires under a microscope shows a "clean" Au/W wire, but a striking surface structural and color changes for the Stablohm wire. (See Fig. 2.) It is plausible that certain metallic

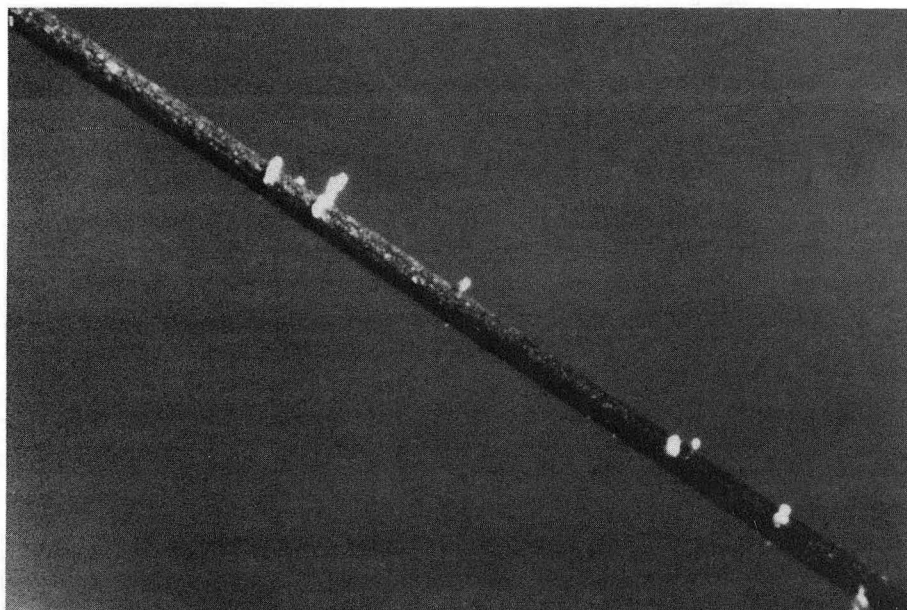

Fig. 2. Photograph of anode wire used in test with test with [Ar (50) + Ethane (50)] + 1.5% ethanol. Wire is made of Stablohm 800, and surface growths (and color change) have occurred after 0.2 Coulombs charge transfer. 400 nA initial current.

CBB 864-2622

Table III.

$$R = - \frac{1}{Q} \frac{\Delta I}{I} \text{ (%/Coulomb) for [50%Ar + 50% Ethane] + Additives}$$

Notes and Symbols: () Used to denote non-standard source intensity (no shims)

a - "Purer" gas

c - Premixed cylinder of |Ar(50) + Ethane (50)| + 1.5% Ethanol

b - Sicomet seal

d - ~0.5% Ethanol

[] Collection of runs all at 400 nA initial current

Gas	Wire/flow (\leq 100 cc/min)	Current (nA) (~gain)						
		2000	1000	700	400	200	100	60
1.5% Ethanol (190 Proof)	Au/W >100	(-12) (2)	19 ^d	(-1)		15 ^d		
	Au/W <100				9, 2 ^{ab}			
	Stablohm >100			(43.9)	[363 ^d , 500 ^d] [1123, 1200]			
	Stablohm <100					938 ^{ab}		
1.5% Ethanol (200 proof)	Au/W <100				35 ^c 11			
	Stablohm <100				245 ^c			
1.0% Hydrogen	Au/W <100			(62)	128			
	Stablohm >100 <100			(96) (70)				
0.2% Hydrogen	Au/W >100	(10)(5)		(86)				
	Au/W <100	(4),(8)		(32)	82	122		
~0.5% Water	Au/W >100	(3)						
	Stablohm >100	(72)						
~0.15% Water	Au/W <100				27			
	Stablohm <100				65			

elements of the Stablohm are reacting chemically with the gas plasma while for the Au/W wire, the gold coating is chemically inert. Later entries in Table III also suggest enhanced reactivity with Stablohm when water vapor is present, though the effect is less than with ethanol vapor. Surface color changes are also seen in this case. There does seem to be some improvement for Au/W wire using water, but not as much as with ethanol. Finally, there appears to be no evidence of improvement through addition of hydrogen, at either the 0.2% or 1.0% level. This is *not* inconsistent with improvements observed in other gases, however.^[7]

The variations between results seen in these tables for tests done under nominally similar conditions is thought not to be due to intrinsic errors in the technique, but due mainly to variations in gas purity from different gas cylinders. In several comparison tests, the *same* gas was used in parallel runs with only one parameter (source strength, gas flow, additive, etc.) being varied to establish its dependence. Errors due to relative current measurement are estimated to be $\lesssim 0.1\%$. The error due to the stochastic nature of deposits on wires is not known, but could be large in the case of some wires having impressive isolated growths (e.g. on Stablohm wire, as shown in Fig. 2). However, because of the observed sensitivity to trace impurities, it is surmised that the principal deviations are from this source. Some of these impurities are in the gas as received from the supplier, and some were evidently due to the use of RTV for tube seals in the earlier runs. The effect of specific impurities can also be different with different gases, of course. Since there is evidence that some gas contaminants can have long-lasting residual effects even after the source of contamination has been removed,^[8] it is possible that the plumbing of the present test apparatus can be vulnerable, since there is no provision for cleaning it after each test. However, such effects cannot be dominant or seriously alter most results, since many of the later tests, using a variety of gases with and without admixtures, have shown very low values of R, and some are consistent with zero.

The wires were photographed after testing. The structural and color changes were frequently found to be quite different for different gas mixtures, or even for the same gas but with some other difference in conditions. Examples of these are shown in Figs. 2, 3 and 4 which are examples of growths on Au/W wire in Ar/ethane, but tested in different gain regions, and having different purity specifications.

IV. CONCLUSIONS

The rate of deterioration of anode wire gain, R, has been found to depend significantly, and in some cases dramatically, on additives, and trace contaminants, in the various gases tested, as well as on the type of wire. In particular, high purity gases yield values of R typically at least ten times smaller than gases of technical grade purity when used with gold-plated wire. On the other hand, even the lower purity gases can be improved by adding water or ethanol vapor, and 1.5% ethanol in Ar (50%) + ethane (50%) has yielded results consistent with $R = 0$. However, Stablohm wire appears to be attacked by use of either of these two vapors in Ar/ethane but especially in the case of ethanol. A most conspicuous example of the sensitivity to contamination is for dimethyl ether, where nearly two orders of magnitude difference in R appears to result from a ~ 20 parts per million contamination of freon 11.

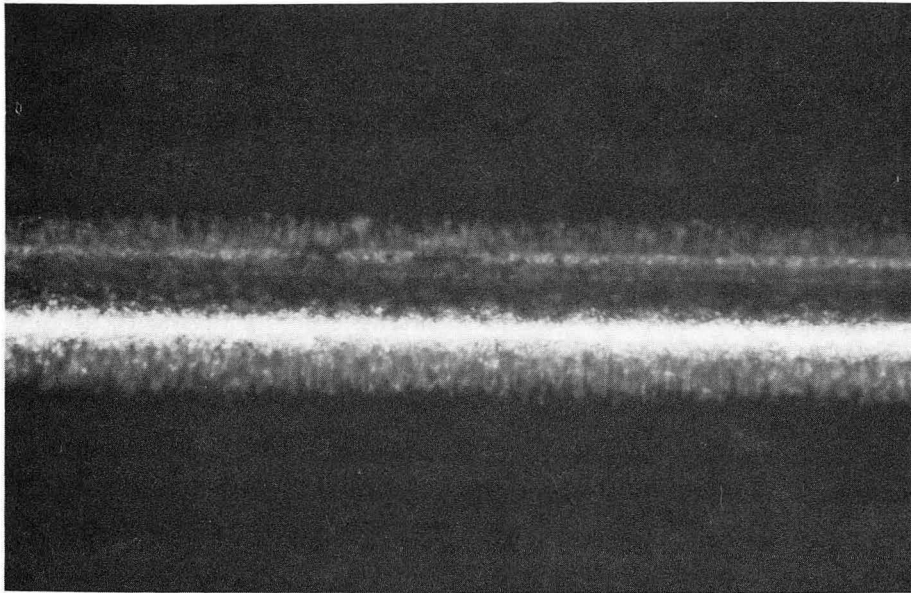

Fig. 3. Anode wire after exposure to 0.5 Coulombs charge, resulting in "bottle-brush" structure. Gas is Ar (50) + ethane (50), wire is gold-plate tungsten, and gain is high (nearly into streamer region): $\sim 2 \mu\text{A}$. CBB 864-2624

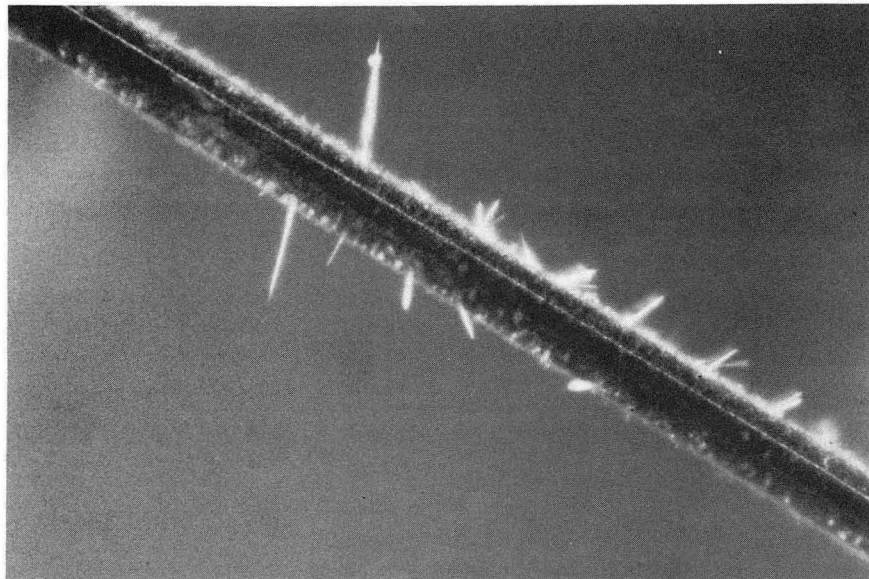

Fig. 4. Anode wire and gas as in Fig. 3, except higher purity gas, and standard (400 nA) gain (tube was sealed with RTV, however); 0.3 Coulombs.

CBB 861-211

There is a systematic trend toward larger values of R when the current, or average gain, is decreased. There also seems to be a dependence of R upon flow rate so that larger flows are generally preferable. Some evidence exists, based upon only one test, that R increases for smaller source intensity.

There are several examples among the tests of very small rates of aging, consistent with zero within the sensitivity of this technique ($R \gtrsim 15$). It is both encouraging that such good results do exist, and stimulating to find the causes of poorer results so that aging possibly may be controlled over a wider range of options.

ACKNOWLEDGMENTS

Most of the plumbing system and the aluminum tubes was built by Doug Shigley, and his very expert assistance was absolutely essential. Valuable (and often beautiful) color microphotographs were taken of each wire after testing by Bill Love, and some are shown here (unfortunately not in color). Amos Newton performed a careful and thorough analysis of an already depleted bottle of DME to search for all manner of contaminants at the few parts per million level, helping greatly our understanding of the behavior of this gas.

REFERENCES

- [1] A partial bibliography has been included below.
- [2] Wire used was supplied by California Fine Wire Co. Stablohm is a trade name of this company. The present gold plated tungsten wire was also obtained from them.
- [3] This has some degree of uncertainty, perhaps as much as a factor of two, due to perturbation of the electric field by the positive ion space charge.
- [4] These analyses were done by Amos Newton of the LBL Chemistry Department. Two of the DME bottles ("pure" and "10-20 ppm") were courtesy of Dave Nygren, LBL.
- [5] See, for example, the paper by R. Kotthaus in Proceedings of the Workshop on Radiation Damage to Wire Chambers, Lawrence Berkeley Laboratory, Berkeley, California, January 16-17, 1986, LBL-21170, UC-34D, CONF-860162, Section 3a, pp. 167-171.
- [6] Private communication with Muzaffer Atac. He has observed a complete degradation of pulse height resolution after only 0.07 C of charge. Furthermore, he has found that the degradation was *not* localized to the irradiated region, but occurred along the entire length of the wire, 10 cm, and also on the adjacent wire, spaced 12 mm away. His work is still in progress on this phenomenon.
- [7] H. Sipila, M. Jarvinen, Nucl. Inst. and Methods **217**, 298 (1983).
- [8] R. Kotthaus, Proceedings of the Workshop on Radiation Damage to Wire Chambers, Lawrence Berkeley Laboratory, Berkeley, California, January 16-17, 1986, LBL-21170, UC-34D, CONF-860162, Section 3c, pp. 174-181, and Fig. 9.

PARTIAL LIST OF REFERENCES ON POLYMERIZATION AND
WIRE CHAMBER DEGENERACY

- Friedland and Katzenstein, Rev. Sci. Instr. 24, 103 (1953).
- den Boggende et al., J. of Sci. Instr. (J. of Phys.)
2, 701 (1969).
- Charpak et al., NIM 99, 279 (1972).
- Spielberg et al., Rev. Sci. Instr. 46, 1086 (1975).
- Bawdekar, IEEE Trans. Nucl. Sci. NS-22, 282 (1975).
- Friedrich and Sauli, CERN EP 77-10 (1977).
- Le Du et al., CERN EP Internal Report 77-11 (1977).
- Faruqi, IEEE Trans. Nucl. Sci. NS-27, 644 (1980).
- Grady and Robertson, NIM 179, 317 (1981).
- Turala and Vermeulen, NIM 205, 141 (1983); CERN EP/82-79.
- Smith and Turner, NIM 192, 475 (1982).
- Sumner, IEEE Trans. Nucl. Sci. NS-29, 1410 (1982).
- Atac, Proceedings of Gas Calorimetry Workshop, 1982, pp. 303-340.
- Adam et al., NIM 217, 291 (1983).
- Sipila and Jarvinen, NIM 217, 298 (1983).
- Dwurzny et al., NIM 217, 301 (1983). Also NIM 228,
267 (1985).
- Binnie et al. (TASSO), Imperial College (London) Report HENP/84/2.
Also, NIM 28, 267 (1985).
- Artemiev et al., NIM 224, 408 (1984).
- Anderson et al., NIM 223, 29, 31 (1984).
- Fischer et al., NIM A238, 249 (1985).
- Kwong et al., NIM A238, 265 (1985).
- Lawrence Berkeley Laboratory, TPC Letter of Intent: Vertex
Chamber Proposal, TPC-LBL-85-20 (1985).

PARTIAL LIST OF BOOKS ON PLASMA POLYMERIZATION

1. M Shen, Plasma Chemistry of Polymers, published by Dekker, New York City, 1976.
2. M. Shen and A. Bell, Plasma Polymerization, published by American Chemical Society, 1979.
3. H. Boenig, Plasma Science and Technology, published by Cornell University Press, Ithaca, NY, 1982.
4. H. Yasuda, Plasma Polymerization, published by Academic Press, 1985.

This report was done with support from the Department of Energy. Any conclusions or opinions expressed in this report represent solely those of the author(s) and not necessarily those of The Regents of the University of California, the Lawrence Berkeley Laboratory or the Department of Energy.

Reference to a company or product name does not imply approval or recommendation of the product by the University of California or the U.S. Department of Energy to the exclusion of others that may be suitable.

*LAWRENCE BERKELEY LABORATORY
TECHNICAL INFORMATION DEPARTMENT
UNIVERSITY OF CALIFORNIA
BERKELEY, CALIFORNIA 94720*