

Lawrence Berkeley National Laboratory

Lawrence Berkeley National Laboratory

Title

ELEMENTAL SULFUR ANALYSIS USING X-RAY TECHNIQUES AND B -GAUGE MASS MEASUREMENTS

Permalink

<https://escholarship.org/uc/item/25f6c74j>

Author

Goulding, F.S.

Publication Date

1977-07-01

LBL-6496
UC-37 c. 2

ELEMENTAL SULFUR ANALYSIS USING X-RAY TECHNIQUES
AND β -GAUGE MASS MEASUREMENTS

F. S. Goulding, J. M. Jaklevic, and B. W. Loo

July 1977

RECEIVED
LAWRENCE
BERKELEY LABORATORY

JUL 19 1978

LIBRARY AND
DOCUMENTS SECTION

Prepared for the U. S. Department of Energy
under Contract W-7405-ENG-48

TWO-WEEK LOAN COPY

*This is a Library Circulating Copy
which may be borrowed for two weeks.
For a personal retention copy, call
Tech. Info. Division, Ext. 6782*

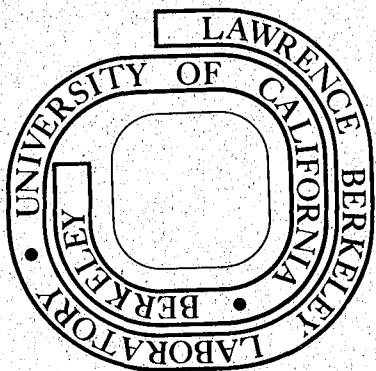

LBL-6496
c. 2

LEGAL NOTICE

This report was prepared as an account of work sponsored by the United States Government. Neither the United States nor the Department of Energy, nor any of their employees, nor any of their contractors, subcontractors, or their employees, makes any warranty, express or implied, or assumes any legal liability or responsibility for the accuracy, completeness or usefulness of any information, apparatus, product or process disclosed, or represents that its use would not infringe privately owned rights.

ELEMENTAL SULFUR ANALYSIS USING X-RAY TECHNIQUES
AND β -GAUGE MASS MEASUREMENTS

F. S. Goulding, J. M. Jaklevic and B. W. Loo

Lawrence Berkeley Laboratory
University of California
Berkeley, California 94720 U.S.A.

Interagency Agreement No. EPA-D5-E681

Contract No. 77 BCG

EPA Project Officer: T. G. Dzubay
Chemistry and Physics Laboratory
National Environmental Research Center
Research Triangle Park, North Carolina 27711

Prepared for

Office of Research and Development, U.S.
Environmental Protection Agency
Washington, D. C. 20460

July 1977

ELEMENTAL SULFUR ANALYSIS USING X-RAY TECHNIQUES
AND β -GAUGE MEASUREMENTS*

F. S. Goulding, J. M. Jaklevic and B. W. Loo

Lawrence Berkeley Laboratory
University of California
Berkeley, California 94720 U.S.A.

SUMMARY

The activities funded under the present EPA/ERDA interagency agreement have been concentrated mainly in two areas. An elemental sulfur monitor for the measurement of fine particulates has been designed, constructed, and is currently being tested at LBL. A prototype of the device will be delivered in the near future. A second program has involved the development of the β -attenuation technique for the large-scale measurement of the masses of particulate deposits. The emphasis has been primarily concerned with the fabrication of improved hardware to perform the measurement conveniently and accurately.

Other activities included consultation with EPA on questions concerning air sampling techniques and X-ray fluorescence analysis of aerosol samples. An additional long-term interest has been the development of X-ray techniques which are capable of determining the chemical form of the sulfur atoms in an environmental sample. Since these latter activities are in a more speculative period of development, the present progress report emphasizes the activities in the area of elemental sulfur monitoring and β -gauge development. Subsequent reports will address themselves to the other areas of interest.

* Work supported in part by the U.S. Energy Research and Development Administration under Interagency Agreement with the Environmental Protection Agency.

Part A
SULFUR MONITOR

INTRODUCTION

The growing importance of sulfur as a component in air pollution has placed emphasis on the development of methods to detect and accurately measure the concentration of sulfur related compounds in atmospheric aerosols. In the case of aerosol particulates, it has been demonstrated that the X-ray fluorescence analysis of samples acquired on thin membrane filters is a reliable and accurate method for the measurement of elemental sulfur.^{1,2} Studies have found that sulfur is present in fine particle urban aerosol predominantly in the sulfate form.³ The measurement of fine particle elemental sulfur by X-ray fluorescence should then be a valid indicator of sulfate concentrations for air pollution research and monitoring purposes.

We have developed a combined air sampler/X-ray fluorescence analyzer designed to automatically perform continuous measurement of particulate sulfur concentrations.

DESCRIPTION OF INSTRUMENT

Figure 1 shows a schematic drawing the of LBL Particulate Sulfur Monitor. It consists of a dichotomous virtual impactor, continuous tape membrane filter supply X-ray fluorescence analyzer, and assorted pumps and flow controllers. The instrument operates under the command of a microprocessor oriented controller which sequences the filter tape past the sampling head and X-ray fluorescence spectrometer. Under normal operating conditions the samples are collected for a predetermined interval (T_s), typically from 1 to 24 hours. The sulfur content is subsequently

measured at the spectrometer for a given analysis period (T_A) of 1000 to 10,000 seconds depending on the sensitivity and accuracy required. (Obviously $T_A < T_S$) Calibration information is then applied to the acquired data which is printed or otherwise communicated to a data monitoring system.

Virtual Impactor

The virtual impactor is adapted from an earlier version which has been extensively field tested and validated over the past three years.⁴ The cross sectional view in Fig. 2 shows a total input flow of 16.7 l/min which is split into two streams of 75% and 25% respectively. All of the coarse particles above 2.4 μm aerodynamic diameter together with 25% of the fine particles are contained in the smaller volume air stream and are subsequently removed by the filter in the bottom of the sampler. The 12.5 l/min flow contains only these particles less than 2.4 μm . It is these particles which are subsequently collected on the thin membrane filter for analysis.

Since the coarse particles are not analyzed in the present mode of operation, the collecting filter is designed to operate free of clogging for long periods. This is done by designing the collector stage as a large particle impactor which preferentially deposits the mass in the center of the filter and allows a large area of flow around the periphery of the filter. No significant change in impedance is expected until the total area of the filter becomes heavily loaded with particulates. It is assumed that periodic maintenance of the inlet device will include cleaning of this filter. The virtual impactor has been designed to be easily accessible and conveniently dismantled and reassembled.

The flow circuit for the dichotomous sampler is illustrated in Fig. 3. There are shown two versions of the sampler utilizing two methods of flow

control. In Fig. 3a, a variable orifice is inserted in series with the collecting filter. A feedback loop maintains the combined impedance of the filter and orifice constant as the filter impedance is increased due to particle loading. The displacement of the variable orifice actuator can be used to indicate the degree of loading which the filter has experienced and appropriate measures taken when it becomes excessive. This design was used in the first prototype model.

In Fig. 3b, a constant differential flow controller is used on the output of the pump. The controller is a self-contained mechanical feedback device which maintains the pressure drop across the reference impedance constant by regulating the flow through the circuit. This device will be incorporated in future samples because of its simplicity and low cost.

In order to determine the degree of particle loading which the filter has experienced a separate pressure switch is used to monitor the pressure drop across the membrane filter itself.

The pump employed in the present flow conditions can produce a pressure drop of 370 Torr the membrane filter at 1.5 cfm (42.5 l/m).

Continuous Filter Tape

The membrane filters are mounted on a continuous strip of 35 mm film backing. The active area of the filter is 1.6 cm^2 (1.43 cm diameter) and they are separated by 7.62 cm on the strip. The film is available with either thin polycarbonate or teflon membranes from a commercial supplier.⁵ The pore size used in the present applicator is 2 μm . The film advance hardware uses standard 35 μm photographic film take-up reels. The film is optically located using additional 1 mm diameter holes which are punched in the strip at the same time as the membrane filters are being mounted.

The use of thin ($\sim 1 \text{ mg/cm}^2$) membrane filters is particularly important for accurate sulfur measurements. Earlier work has demonstrated that the most serious source of error in the X-ray fluorescence analysis of fine particle sulfur is due to the penetration of the particles into the membrane and the resulting attenuation of the sulfur X-rays as they leave the sample. For a 1 mg/cm^2 filter, the attenuation due to a uniform distribution of particles in this thickness of filter would be 18%. This would represent the extreme case of complete particle penetration which has previously been observed only in high ambient relative humidity with cellulose membrane filters. Since the teflon and polycarbonate membranes are hydrophobic, such occurrences are avoided.

A potentially serious drawback to the use of teflon filters is their susceptibility to increased impedance at moderate particle loading. For example, a $1.2 \text{ }\mu\text{m}$ pore size Millipore filter can tolerate fine particle mass loadings of $200 \text{ }\mu\text{g/cm}^2$ before the impedance doubles. By contrast, the teflon show similar effect at less than $100 \text{ }\mu\text{g/cm}^2$ while polycarbonate membranes are intermediate between the two. Assuming an ambient fine particle concentration of $100 \text{ }\mu\text{g/m}^3$ of air, a $100 \text{ }\mu\text{g/cm}^2$ filter loading will occur in 127 minutes or 2 hours of sampling with the present design. The resultant doubling of filter impedance will cause the flow controller to exceed its maximum operating range. For this reason, the microprocessor controller is programmed to monitor the rate of loading of the filter and reduce the sampling interval if necessary.

X-ray Spectrometer

The X-ray analyzer consists of a single channel Bragg reflection (wavelength dispersive) spectrometer. It operates on the principle that

X-rays incident on a perfect crystalline array of atoms will be reflected from the surface if the Bragg relationship is satisfied.

$$\lambda = 2d \sin\theta$$

where λ is the wavelength of the incident X-ray* ($\lambda = 5.375\text{\AA}$ for the S K_α X-ray), d is the crystalline spacing of the atomic array. ($2d = 6.532\text{\AA}$ for the Ge $\langle 111 \rangle$ atomic plane) and θ is the angle at which the reflection occurs. ($\theta = 55.4^\circ$ for the present case as defined in Fig. 4.) Of course other wavelengths which are incident on the crystal can be reflected at other angles near to the main line of interest. In order to make the spectrometer selective for a given X-ray wavelength (or energy) the range of incident angles must be restricted. The Söller slits in Fig. 4 limit the angular divergence to 8×10^{-3} radians in the plane of the reflection. From Eq. 1 we can derive a quantitative relationship between angular divergence and energy resolution.

$$\frac{\Delta\lambda}{\lambda} = \frac{\Delta E}{E} = \frac{\Delta\theta}{\tan\theta} \quad (2)$$

The excellent energy resolution of such spectrometer is achieved at the cost of reduced intensity since the acceptance angle of the spectrometer is proportional to $\Delta\theta$. In the present design, an energy resolution of 13eV at 2.307 keV was selected as a reasonable compromise between maximum intensity and sufficient resolution to avoid interference from the Pb M_α X-rays at 2.342 keV.

Excitation of the fluorescence is provided by a Ag anode X-ray tube operating at 15 kV and 6 mA. The output from the tube has intense characteristic Ag L X-rays at 3 KeV which is slightly above the S K edge at

*The wavelength and energy of X-rays are inversely related through the De Broglie relationship $\lambda(\text{\AA}) = 12.4/E(\text{keV})$.

2.47 keV and is nearly optimum for efficient excitation. The 90 watts of anode power are easily dissipated in an air-cooled heat exchanger.

As indicated in Fig. 4, the X-ray tube output is incident at the lower surface of the filter whereas the particulate deposit is on the upper surface facing the spectrometer. The particular geometry was designed to minimize the air path which the $S K_{\alpha}$ radiation must travel before reaching the detector. This distance is maintained at 2 mm corresponding to a 93% transmission in air. The Ag L excitation is transmitted 75% by a 2 cm path length. This slight reduction in excitation intensity is more than compensated by the convenience of analyzing the sample in ambient air as opposed to He or vacuum surroundings.

CONTROL AND AUTOMATION

Figure 5 illustrates the features of the calculator/controller which is used in automatic sulfur analysis. The instrument is first calibrated in terms of counts/second per $\mu\text{g}/\text{cm}^2$ using a thin sulfur standard. This number is corrected for the flow rate in the small particle branch of the sampler in order that the results can be expressed in $\mu\text{g}/\text{m}^3$ of air. It is then entered from the keyboard. A blank filter is run for a predetermined time and the results stored as counts/second (N_B).

The sampler is then ready for operation. The desired starting time, sampling interval, and analysis interval T_A are then entered via front panel switches. At the preselected starting time, a filter will be positioned and clamped and the flow will be maintained for the appropriate interval. At the end of that interval, the film is advanced and a new membrane filter is clamped in the sampling location as the previous filter advances to the analysis station. The sampling and analysis then proceed simultaneously.

At the end of the analysis period the results are calculated according to Eq. 3 and the results printed.

$$C = \frac{(N_c - N_B T_A)}{T_A T_S} S \quad (3)$$

where N_c is the result of the present measurement, N_B is the background counting rate, and S is the sensitivity factor. In the case of filter overloads which result in a shortened T_A , the results are automatically corrected for this reduced time.

RESULTS

The individual component including flow system, film transport, and X-ray spectrometer have been tested and found to meet design specifications. The first prototype is completed and awaits final debugging and field testing. A second prototype is being designed and built in order to overcome certain design problems which become obvious during the testing stage of the first prototype. The newer design will incorporate an improved and consequently more reliable mechanical transport system and a more efficient calculator/controller design. The second prototype is due to be delivered to the EPA in the fall of 1977.

Table 1 is a summary of performance data obtained using the first prototype. In general, the sampler/analyzer has realized the design goals for sensitive and accurate sulfur measurements. Improvements in sensitivity could be achieved by using thinner Be windows for the spectrometer and proportional counter. In addition, an increase of 20% in counting rate has been achieved by using a Ti anode instead of the Ag. However, the Ti tube is not as reliable as the Ag due to the gas absorbing properties of the Ti material. In view of the observed performance it is felt that no additional refinements in the spectrometer parameters are necessary at this time.

Part B
BETA-GAUGE MASS MEASUREMENTS

INTRODUCTION

As a consequence of an involvement in the analysis of large numbers of samples in the St. Louis RAPS study we have developed a beta-gauge for the automatic measurement of air particulate deposits. The beta-gauge method is based on the attenuation which a continuous beta-spectrum undergoes when traversing a thin layer of matter. The total number of transmitted particles is given as

$$I = I_0 e^{-\mu x} \quad (4)$$

where I_0 is the incident flux, μ is the mass absorption coefficient in cm^2/gm , and x is the thickness of the layer traversed expressed in gm/cm^2 . Although there are empirical expressions which relate the coefficient μ to the energy of the beta spectrum, no complete theory for this particular behavior has been developed. In practice the mass adsorption coefficient is determined experimentally for a given set of conditions.

A typical measurement program consists of calibrating the instrument using a series of uniform standards which span the mass range of interest and which replicate the sample form. For the St. Louis RAPS study the aerosol samples were deposited on cellulose membrane filter with a nominal thickness of $4 \text{ mg}/\text{m}^2$. The parameters I_0 and μ are then determined from a fit to the curve of I vs. x , where I is the number of counts measured in the β -spectrum in a given time interval. For a stable, well-designed system and accurately measured standards, the experimental data can be fit to a pure experimental fraction to a root mean square accuracy of $3 \text{ } \mu\text{g}/\text{cm}^2$ for a 100 second measurement.

Subsequent measurements of unknown samples consist in counting for a specified time interval and calculating the unknown mass from Eq. 4 assuming I_0 and μ as determined from the fit. The convenience of the measurement causes it to be a candidate for use on large scale programs where automation is necessary.

The subtleties of the β -gauge method as implemented in the St. Louis RAPS study have been discussed in previous EPA reports.^{6,7} The emphasis of the present program has been to develop hardware which successfully accomplishes this task. Second phase of this program will be described following a brief general description of the basic instrument.

EXPERIMENTAL PROCEDURE

Figure 6 is a schematic of a simplified β -gauge consisting of source, detector, and sample. The source to detector distance is maintained constant by the rigid mounting yoke. The sample (or standard) is placed between the source and the detector and the counting rate measure.

The overall stability of the source to detector geometry and the associated counting electronics must be adequate to detect a $5 \mu\text{g}/\text{cm}^2$ or less change in a nominal $4 \text{ mg}/\text{cm}^2$ mass. This also implies a statistical accuracy in the counting measurement of 1 part in 10^3 which requires a total number of counts exceeding 10^6 . For a spectrometer capable of 10^5 cps, this implies a measurement time of 10 or greater. In the analysis of the St. Louis samples analysis times of 30 seconds for the unknown sample and 100 seconds for standards were routinely employed.

Additional constraints placed upon amplifier gain and geometric stability were in the range of 1 part in 10^4 over a period of several hours.

They were achieved only through careful design of the hardware and constant control over the ambient operating conditions.

Fortunately one of the less critical parameters is the reproducibility of placement of the samples in the measurement region. This allows the use of automatic sample handling devices which greatly facilitates a large scale study. In the current analysis program, a computer based control and data acquisition system is used for the large scale mass measurement.

β -gauge mass determinations are performed on membrane filters before and after the collection of air particulates and are written on magnetic tape output. A computer program performs the necessary calibration fits and converts the scaler counts to mg/cm^2 . The result of mass determination before and after exposure are then compared and the mass of the particulate deposit determined.

β -GAUGE WITH LIQUID NITROGEN COOLED DETECTOR

The first version of the β -gauge employed a 25 mm diameter, 6 mm thick Si(Li) detector which was maintained at liquid nitrogen temperature (-196°C) in a vacuum cryostat. The low temperature operation was presumed necessary in order to reduce the electronic noise to an acceptable level. This device operates at approximately 7 keV energy resolution with a 2 μsec shaping time at counting rates of the order of 10^5 counts per second. The β -source was a Pm^{147} 300 μC source purchased commercially. The specifications called for a 1 cm diameter deposit uniform to $\pm 10\%$ over that area. The source was covered with a thin layer of polyamide varnish in order to insure physical integrity while handling. The source is mounted in a separate vacuum chamber with a 0.025 μm Al window.

Since the construction of this system almost three years ago, it has operated continually in the St. Louis RAPS program. More than 45,000 individual mass measurements have been made to date with 25,000 yet to go. These data are accurate to $\pm 10 \mu\text{g}/\text{cm}^2$ and have been validated in intercomparison studies.

THERMODYNAMICALLY COOLED β -GAUGE SYSTEM

The principle drawback of the liquid nitrogen cooled detector is the required replenishment of the nitrogen supply in the cryostat and the bulk of the associated dewar. Operating experience gained with this early system showed that an increase in energy resolution could be tolerated without a significant effect on the β -gauge measurement.

The second β -gauge consisted of a similar Si(Li) detector cooled to approximately -70°C by means of a thermoelectric cooling device. In place of the LN cryostat, this device requires only a small vacuum chamber to prevent the detector from collecting condensable vapors and a power supply to drive the thermoelectric cooler. However in order to maintain the 1 part in 10^4 stability it was found necessary to stabilize the temperature of the detector by means of a feedback loop which controls the power level of the cooler. This, together with the pumping equipment required to maintain the vacuum chamber, we increased the complexity of this device beyond the original sample concept.

A prototype of this system together with an automatic sample charger was built and evaluated at this laboratory. In November 1976 it was shipped to the EPA laboratories at Research Triangle Park for their evaluation.

It has operated successfully there although it has not been used as extensively as the liquid nitrogen cooled device which we have at LBL.

ROOM TEMPERATURE β -GAUGE

The next step in reducing the complexity of the system is to eliminate the detector cooling altogether. We are currently testing such a spectrometer which employs a 400 μ m depletion depth surface barrier detector with 21 mm diameter active area. The resolution of the system is approximately 20 keV. Tests of electronic stability are currently being performed. In addition, a series of experiments are proposed which will take advantage of the flexible detector geometry available without the cooling apparatus. By optimizing source, sample, and detector configuration, it is hoped that certain artifacts observed in the earlier β -gauge measurements could be reduced.

This device will likewise be incorporated in an automatic β -gauge. A smaller calculator/computer (Hewlett Packard 9815) will be used to control the sample sequencing and storage of the data. In addition, the calculator will be capable of performing on-line least squares fits to the calibration data together with the calculation of individual sample masses.

REFERENCES

1. Loo, B. W., R. C. Gatti, B. Y. U. Liu, C. S. Kim and T. G. Dzubay, "Absorption Corrections for Submicron Sulfur Collected in Filters", In X-ray Fluorescence Analysis of Environmental Samples, T. B. Dzubay, Ed., Ann Arbor Science, 1977, pp. 187-202.
2. Loo, B. W., W. R. French, R. C. Gatti, F. S. Goulding, J. M. Jaklevic, J. Llacer and A. C. Thompson, "Large Scale Measurement of Airborne Particulate Sulfur", proceedings of the International Symposium on Sulfur in the Atmosphere, Sept. 7-14, 1977, Dubrovnik, Yugoslavia. To be published in Atmospheric Environment, V. 12, No. 1, 1978.
3. Steven, R. K., T. G. Dzubay, G. Russwurm and D. Rickle, "Sampling and Analysis of Atmospheric Sulfate and Related Species", proceedings of the International Symposium on Sulfur in the Atmosphere, Sept. 7-14, 1977, Dubrovnik, Yugoslavia. To be published in Atmospheric Environment, V. 12, No. 1, 1978.
4. Loo, B. W., J. M. Jaklevic and F. S. Goulding, "Dichotomous Virtual Impactors for Large-Scale Monitoring of Airborne Particulate Matter", in Fine Particles: Aerosol Generation, Measurement, Sampling and Analysis, B. Y. H. Liu, Ed., Academic Press, 1976, New York, pp. 311-350.
5. Available from the Ghia Corporation, Pleasanton, California.

6. Goulding, F. S., J. M. Jaklevic and B. W. Loo, "Fabrication of Aerosol Monitoring System for Determining Mass and Composition as a Function of Time", Environmental Protection Agency Report No. EPA-650/2-75-048, EPA Research Triangle Park, North Carolina, 1975.
7. Goulding, F. S., J. M. Jaklevic and B. W. Loo, "Development of Air Particulate Monitoring Systems" Progress Report to the Environmental Protection Agency, Lawrence Berkeley Laboratory Report No. LBL-6497, 1977.

Table 1. Measure Detectabilities for Sulfur Analysis^a

| Sample Interval T_s (hrs) | Analysis Interval T_A (sec) | Detectable Limit ^b $\mu\text{gm}/\text{m}^3$ |
|--------------------------------|----------------------------------|--|
| 1 | 1000 | 0.32 |
| 1 | 2000 | 0.23 |
| 2 | 1000 | 0.16 |
| 2 | 4000 | 0.10 |
| 12 | 1000 | 0.026 |
| 12 | 10000 | 0.008 |

^aAssumes 100 watts at anode power.

^bExpressed as 3σ where σ is the standard deviation in the background obtained with a blank filter.

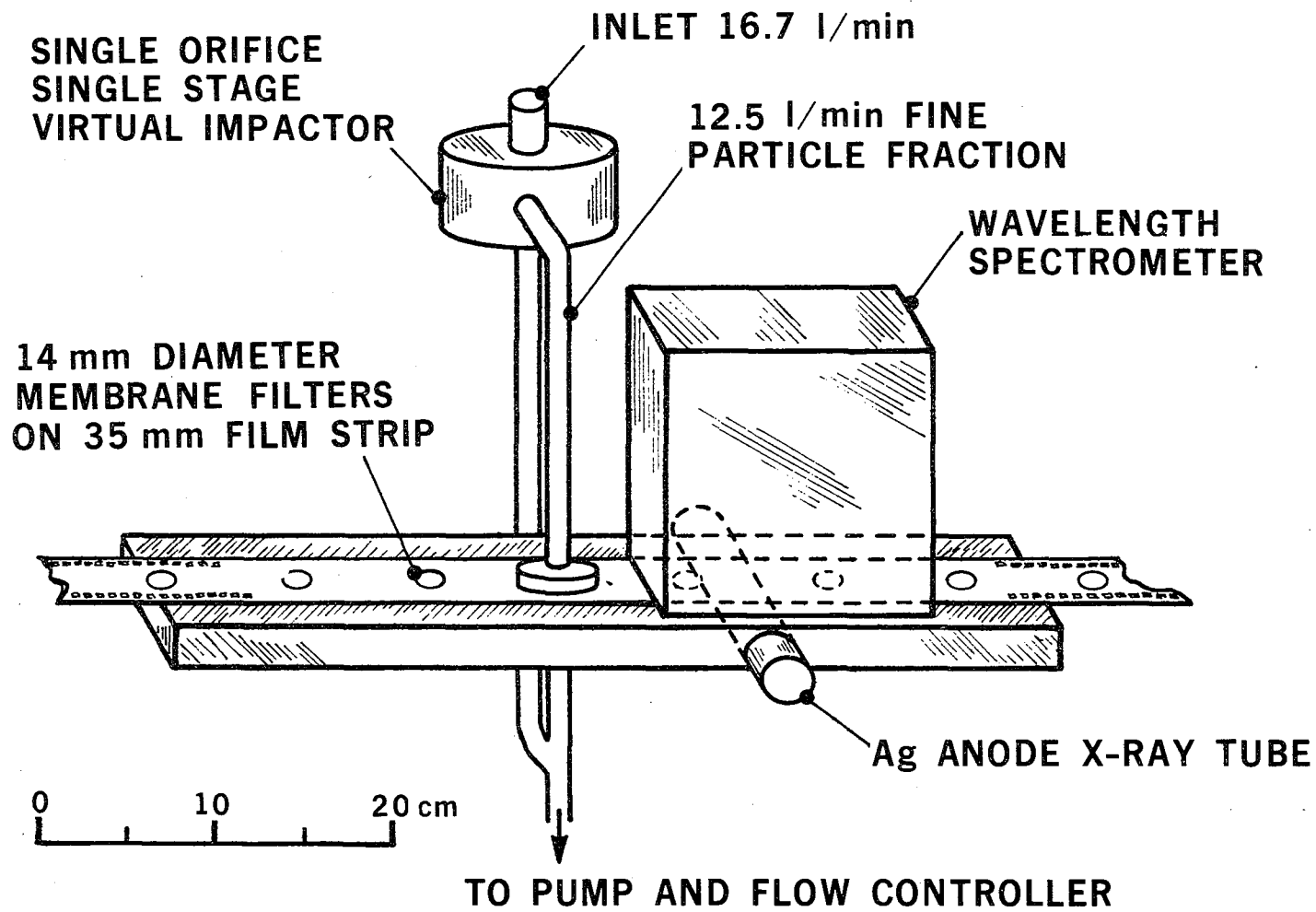
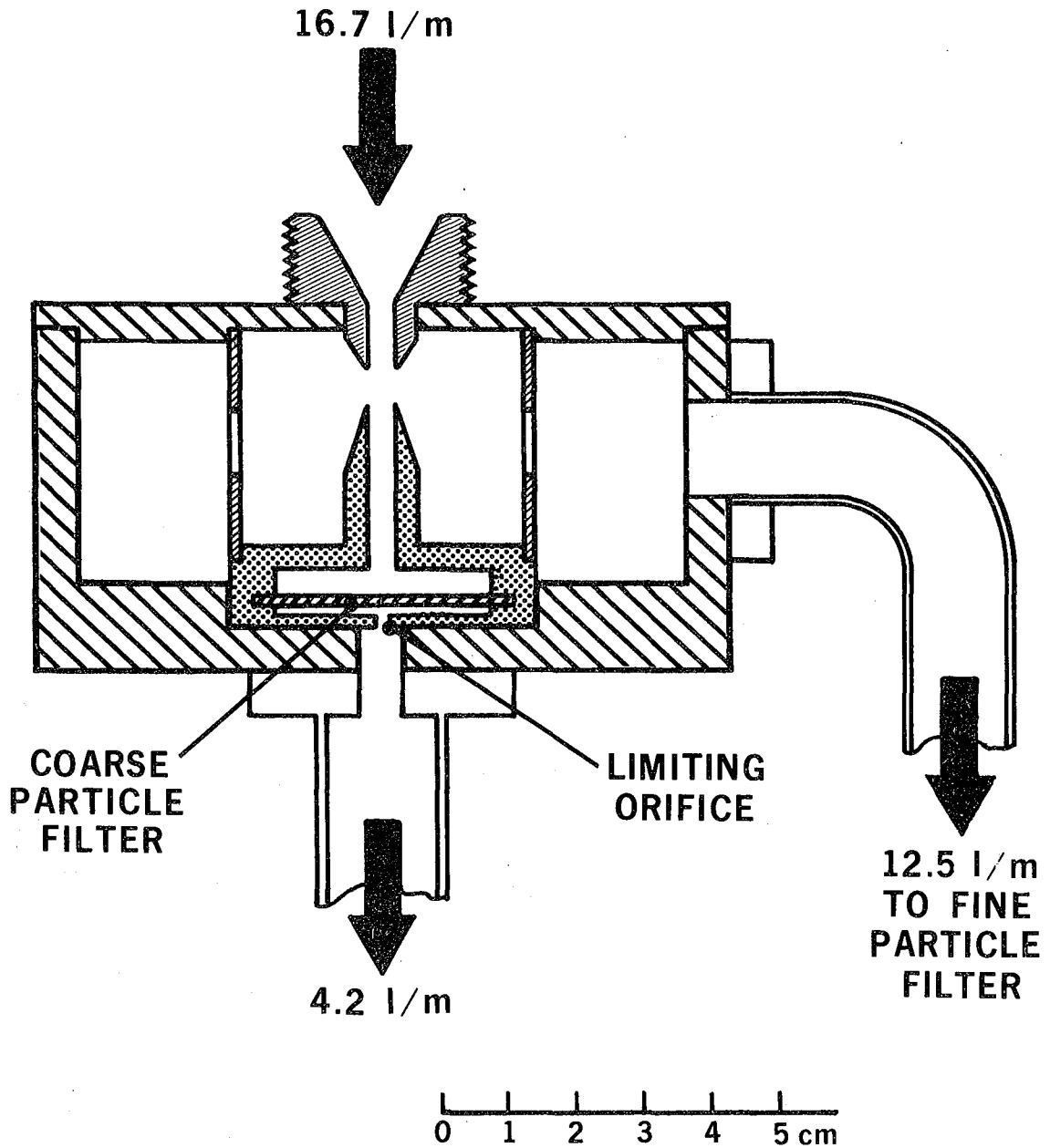

Fig. 1. Schematic Drawing of Sulfur Monitor.

XBL 776-9331



XBL 776-9333

Fig. 2. Cross-Section of Virtual Impactor.

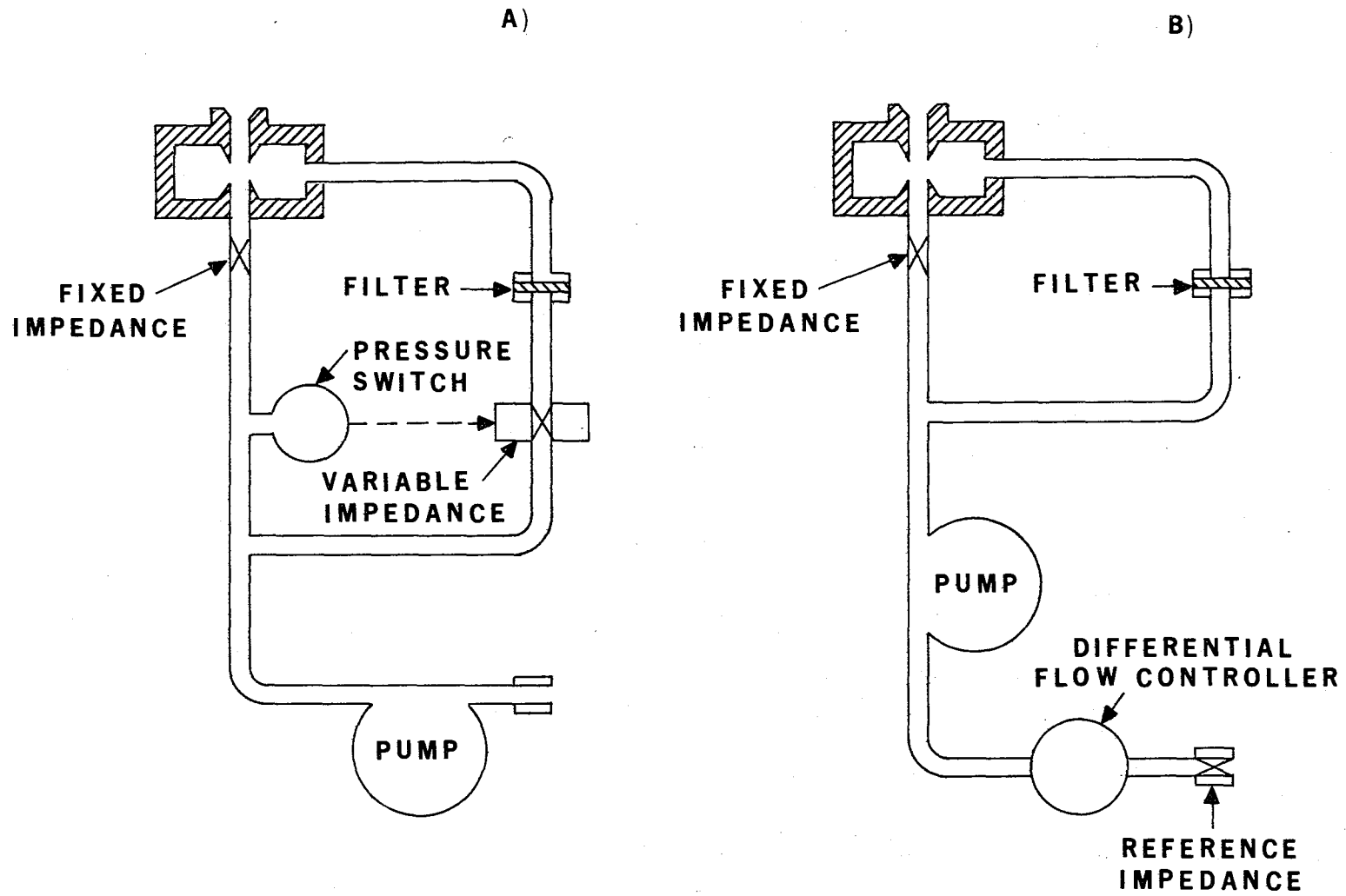
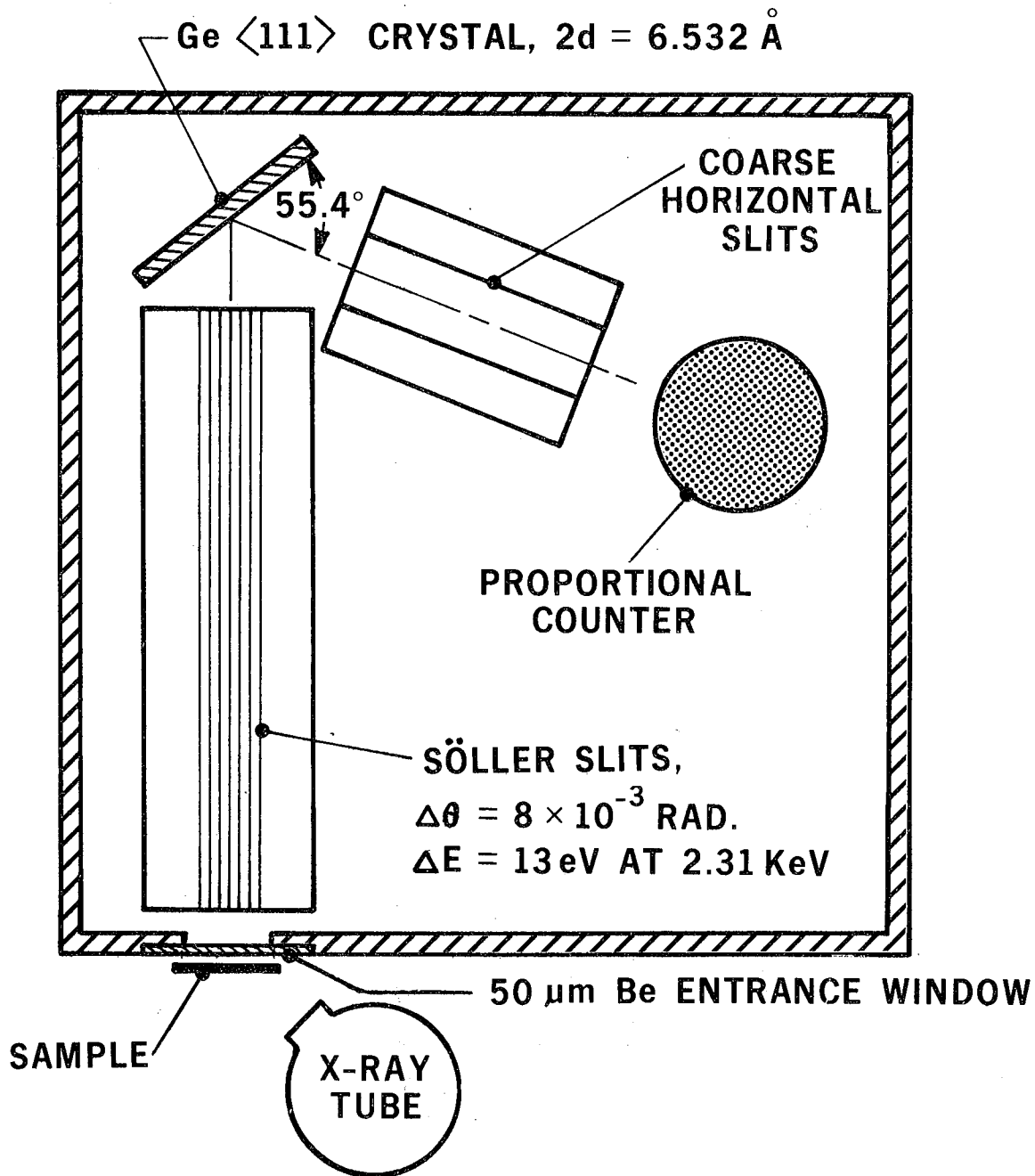

Fig. 3. Flow diagrams for two versions of the single state dichotomous sampler.

XBL 776-9358



XBL 776-9332

Fig. 4. Schematic drawing of the wavelength spectrometer.

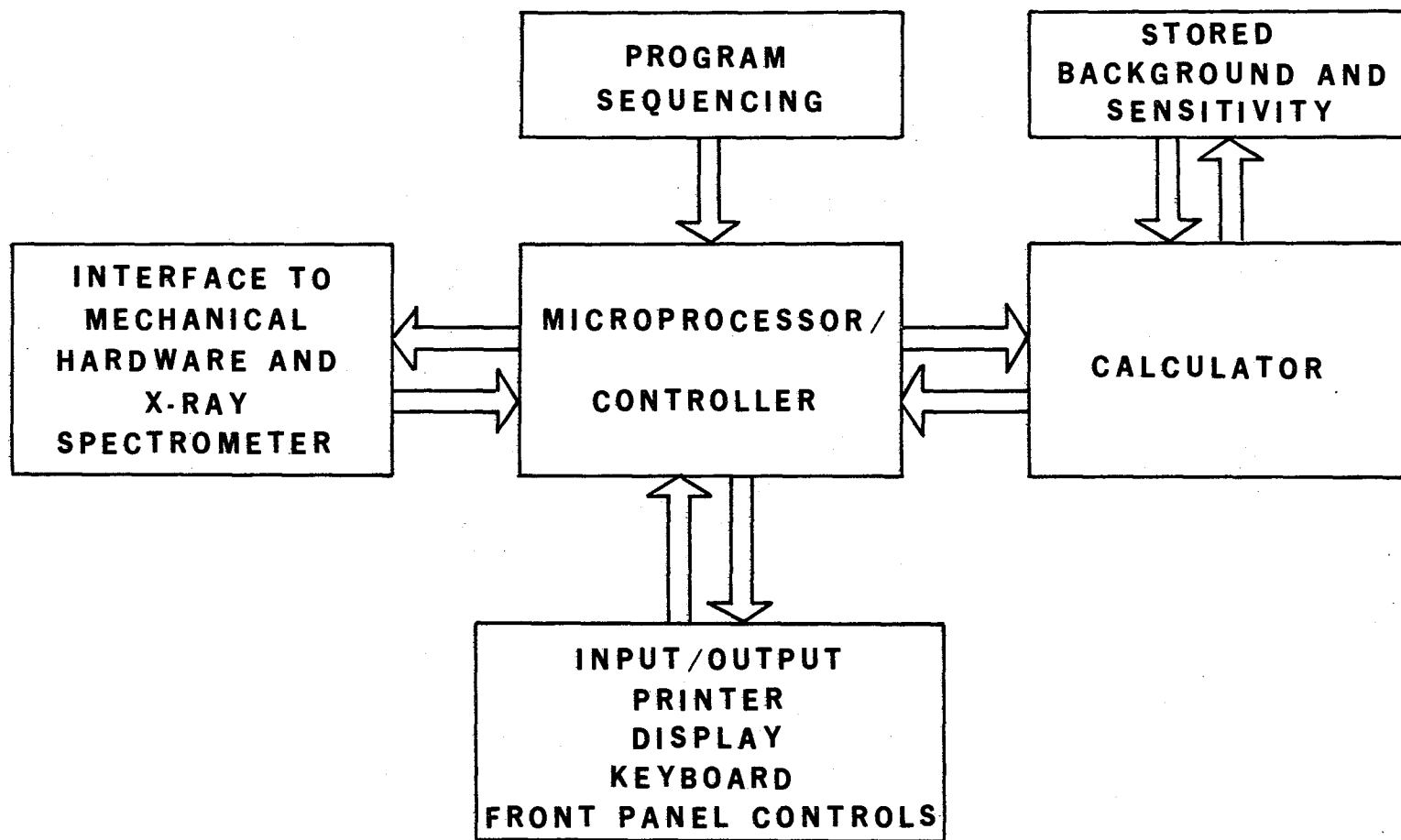

XBL 776-9446

Fig. 5. Control electronics for automatic sulfur sampling and analysis.

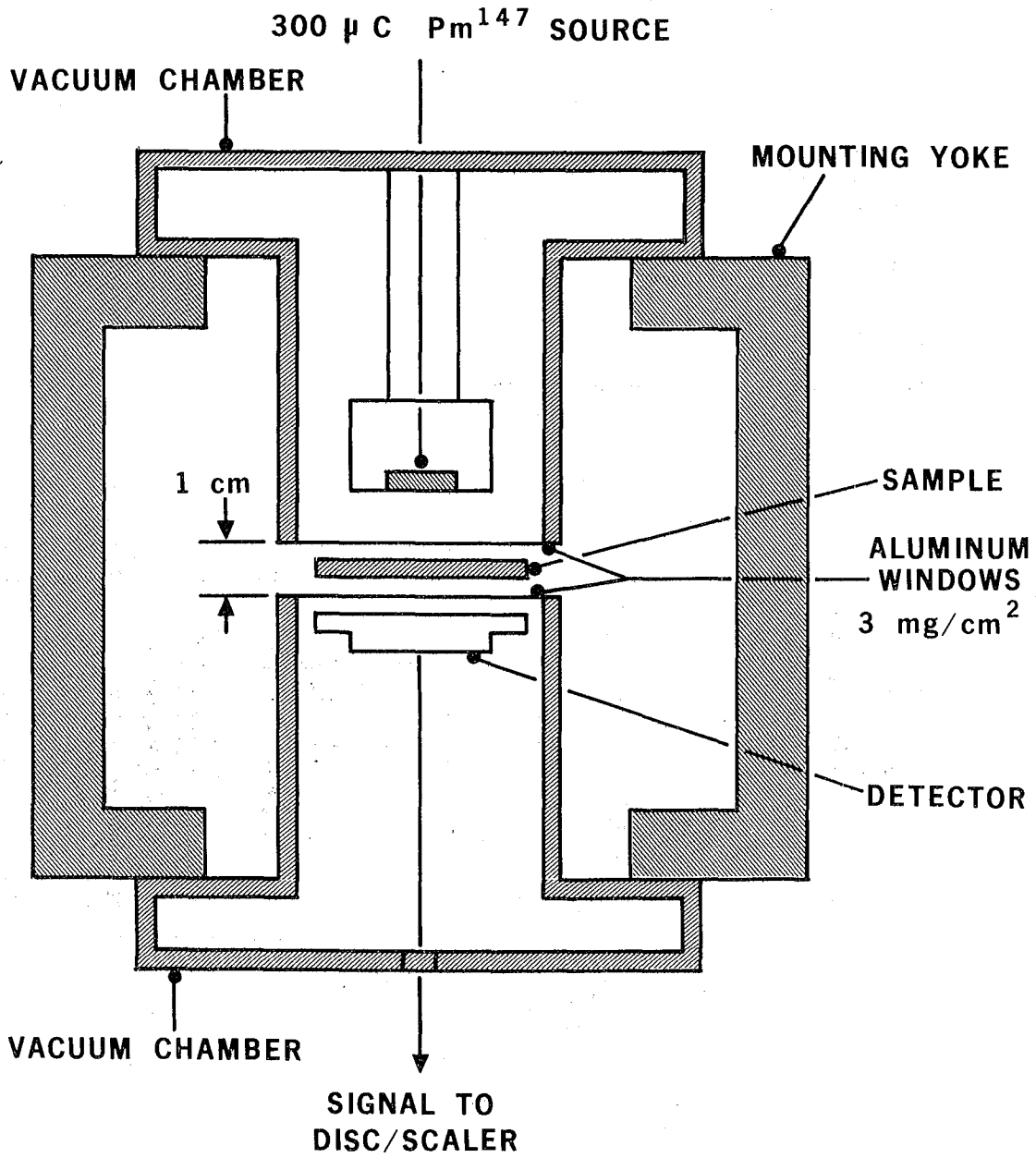

This report was done with support from the Department of Energy. Any conclusions or opinions expressed in this report represent solely those of the author(s) and not necessarily those of The Regents of the University of California, the Lawrence Berkeley Laboratory or the Department of Energy.

TECHNICAL INFORMATION DEPARTMENT
LAWRENCE BERKELEY LABORATORY
UNIVERSITY OF CALIFORNIA
BERKELEY, CALIFORNIA 94720