

# Lawrence Berkeley National Laboratory

## Lawrence Berkeley National Laboratory

### **Title**

Cooling the Planet: Opportunities for Deployment of Superefficient Room Air Conditioners

### **Permalink**

<https://escholarship.org/uc/item/253583c5>

### **Author**

Shah, Nihar

### **Publication Date**

2013-08-30

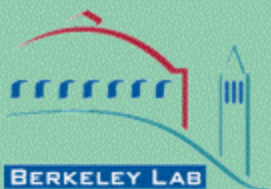

**ERNEST ORLANDO LAWRENCE  
BERKELEY NATIONAL LABORATORY**

Cooling the Planet: Opportunities for Deployment of  
Superefficient Room Air Conditioners

Nihar Shah<sup>1</sup>, Paul Waide<sup>2</sup>, Amol Phadke<sup>1</sup>

LBLN-XXXX

<sup>1</sup> Environmental Energy Technologies Division,  
International Energy Studies Group,  
Lawrence Berkeley National Laboratory

<sup>2</sup> Navigant Consulting, Inc.

This work was funded by the Bureau of Oceans and International Environmental and Scientific Affairs, U.S. Department of State, and administered by the U.S. Department of Energy in support of the Super-efficient Equipment and Appliance Deployment (SEAD) initiative through the U.S. Department of Energy under Contract No. DE-AC02-05CH11231

### **Disclaimer**

This document was prepared as an account of work sponsored by the United States Government in support of the Super-efficient Equipment and Appliance Deployment (SEAD) initiative. While this document is believed to contain correct information, neither the United States Government nor any agencies thereof, SEAD participating Governments nor any agencies thereof, the SEAD Operating Agent, The Regents of the University of California, Navigant Consulting Inc. nor any of their employees, makes any warranty, express or implied, or assumes any legal responsibility for the accuracy, completeness, or usefulness of any information, apparatus, product, or process disclosed, or represents that its use would not infringe privately owned rights. Reference herein to any specific commercial product, process, or service by its trade name, trademark, manufacturer, or otherwise, does not necessarily constitute or imply its endorsement, recommendation, or favoring by the United States Government or any agency thereof, SEAD participating Governments or any agencies thereof, the SEAD Operating Agent, Navigant Consulting Inc. or The Regents of the University of California. The views and opinions of authors expressed herein do not necessarily state or reflect those of the United States Government or any agency thereof, SEAD participating Governments or any agencies thereof, the SEAD Operating Agent, Navigant Consulting Inc. or The Regents of the University of California.

Ernest Orlando Lawrence Berkeley National Laboratory is an equal opportunity employer.

# Contents

<b>Contents .....</b>	<b>iii</b>
<b>List of Figures .....</b>	<b>v</b>
<b>List of Tables .....</b>	<b>vii</b>
<b>Abbreviations and Acronyms.....</b>	<b>viii</b>
<b>Executive Summary.....</b>	<b>1</b>
<b>Chapter 1 Introduction.....</b>	<b>11</b>
1.1 Super-Efficient Equipment and Appliance Deployment Initiative (SEAD) .....	11
1.2 Objective and Scope .....	11
1.3 Analysis Method and Data Sources.....	12
1.4 Organization of this Report.....	12
<b>Chapter 2 Engineering Analysis.....</b>	<b>14</b>
2.1 Types of Residential Air Conditioner .....	14
2.2 Water-cooled Systems.....	23
2.3 Opportunities to Increase Air Conditioner Efficiency .....	24
2.3.1 Classic Component Options Across all Economies .....	24
2.3.2 Other Options.....	42
<b>Chapter 3 Room AC Market and Energy Consumption Trends.....</b>	<b>48</b>
3.1 Split Packaged ACs Are the Dominant Type of Residential Air Conditioner.....	48
3.2 Average Capacity .....	49
3.3 Significant Potential for Efficiency Improvement Exists .....	50
3.4 Deployment of Variable Speed Compressors is Increasing.....	51
3.5 Deployment of Reversible ACs varies with climate and habit patterns.....	52
3.6 Room AC Sales in Emerging Economies are High and Growing Rapidly.....	53
3.7 Ongoing Development of Alternative Refrigerants.....	54
<b>Chapter 4 Cost Effectiveness Analysis .....</b>	<b>56</b>
4.1 Room AC Components and Design Options .....	58
4.2 Cost-Efficiency Model Methodology .....	60
4.3 Other Data Inputs.....	64
4.4 Cost Effectiveness Analysis using the Cost of Conserved Electricity .....	65

4.2.1	Cost of Conserved Electricity Methodology .....	66
4.2.2	Using Cost of Conserved Electricity for Market Transformation Program Design .....	66
4.2.3	Cost Effectiveness Analysis Results .....	69
4.2.4	Price Learning.....	70
<b>Chapter 5 Energy Saving Potential .....</b>		<b>72</b>
5.1	Savings Potential Methodology and Data Sources .....	72
5.2	Energy Savings Potential.....	73
5.3	Cost Effective and Total Energy Savings Potential .....	75
<b>Chapter 6 Conclusions .....</b>		<b>77</b>
Technical Data Can Be Used for Integrated Market Transformation Program Design .....		77
Cost-effectiveness Metrics Could be Expanded .....		77
Low GWP/ODP Refrigerants Can Have a Cost and Efficiency Impact.....		77
<b>Acknowledgments .....</b>		<b>78</b>
<b>References.....</b>		<b>78</b>
<b>Appendix A: Climate Specific Efficiency Improvement Options .....</b>		<b>83</b>
Evaporative Cooling.....		83
Phase Change Materials .....		88
Free Cooling for Window/Louvered Air Conditioners .....		90
Storage of Cooling at Night.....		92
Radiative cooling – Cool Roofs .....		93
Shading with vegetation.....		94
<b>Appendix B. AC Manufacturing Cost Curves for Various Economies .....</b>		<b>96</b>
<b>Appendix C: Rebound Effect.....</b>		<b>102</b>
A.	Theoretical Principle.....	102
B.	Empirical Evidence.....	103
C.	Summary of Rebound Effect.....	104
<b>Appendix D: Sensitivity Analysis.....</b>		<b>105</b>

## List of Figures

Figure E-1 Current and projected Room AC Sales in various countries (logarithmic scale) Source: BSRIA, and CLASP Mapping Report (Baillargeon, 2011).....	4
Figure E-2 Cost to Consumer of Conserved Electricity (CCEc) Versus Room AC Efficiency for Various Economies.....	7
Figure E-2 Cost Curves and Market Transformation Programs.....	9
Figure 2-1: Central air conditioner of the split type .....	22
Figure 2-2: Compression cycle in rotary fix-vane compressors .....	25
Figure 2-3: Compression cycle in a scroll compressor.....	26
Figure 2-4: Compression cycle in the reciprocating compressor .....	26
Figure 2-5: Efficiency of fractional horsepower motors.....	27
Figure 2-6: Evolution of Motor Current Waveform.....	28
Figure 2-7: COP (W/W) as a function of cooling capacity for an inverter driven AC.....	29
Figure 2-8: Types of Different Fans .....	30
Figure 2-9: Evolution in Japanese air conditioner fan motor efficiency .....	30
Figure 2-10: Evolution of Axial/Propeller Fan Design .....	31
Figure 2-11: Axial Fan Design for A/C Condenser under High Static Pressure .....	32
Figure 2-12: Latest Design of Cross Flow Fan Design .....	32
Figure 2-13: Turbo Fan with 3-D Blades .....	33
Figure 2-14: Evolution in mass and dimensions of 2.8 kW AC units in Japan .....	34
Figure 2-15: Fin Pattern Evolution.....	35
Figure 2-16: Evolution of copper tube designs for indoor coils in Japan.....	35
Figure 2-17: Electronic Expansion Value Schematic .....	37
Figure 2-18: Variation of heating capacity as a function of outdoor air temperature of an air-based heat pump with vapor injection.....	39
Figure 2-19: Improvement for low ambient heat pump cycle- Expander cycle, (b) Refrigerant ejector cycle, (c) vortex tube cycle.....	40
Figure 2-20: Outdoor Piping Modifications to Increase Frost Condition Performance.....	40
Figure 2-21: Freeze Prevention Pipe for Outdoor Unit Bottom Pipe .....	41
Figure 2-22: The modified cycle including liquid vapor heat exchanger schematic.....	41
Figure 2-23: Relationship between efficiency and refrigerant charge per kW of cooling capacity.....	42
Figure 3-1 Current and projected AC Sales in various countries .....	53
Figure 3-2 Current (HFC) and possible future refrigerant alternatives (Source: Author's Interpretation from Rajendran, 2011) .....	55
Figure 4-1 Cost Effectiveness Analysis .....	56
Figure 4-2 "Cloud" of 1728 Cost-ESEER pairs .....	60
Figure 4-3 Example of Manufacturing Cost versus ESEER Curve for Australia.....	64
Figure 4-5 Market Transformation Program Design Example.....	67
Figure 4-5 Cost (to consumer) of Conserved Electricity (CCEc) Versus Room AC Efficiency for Various Economies.....	69
Figure 4-6 Cost (to manufacturer) of Conserved Electricity (CCEm) Versus Room AC Efficiency for Various Economies .....	70
Figure 5-1 Cost of Conserved Electricity versus Annual Energy Savings in 2020.....	74
Figure A-1: Typical direct evaporative air conditioner.....	84

Figure A-2: Indirect-direct evaporative air-conditioning process .....	85
Figure A-3: Air cycle for the desiccant cooling system.....	86
Figure A-4: (a) Physical DEVap concept; (b) Illustration of DEVap air conditioning unit.....	87
Figure A-5: Solar powered evaporative air conditioner .....	88
Figure A-6: PCM storage tank integrated with an air conditioner unit and air/water heat exchanger .....	89
Figure A-7: Diagrammatic Representation of an Economizer .....	91
Figure A-8: Schematic diagram of Combined A/C, water heater and energy storage system.....	93
Figure B-1: Manufacturing Cost vs ESEER for Australia.....	96
Figure B-2: Manufacturing Cost vs ESEER for Brazil.....	96
Figure B-3: Manufacturing Cost vs ESEER for Canada.....	97
Figure B-4: Manufacturing Cost vs ESEER for China.....	97
Figure B-5: Manufacturing Cost vs ESEER for the EU .....	98
Figure B-6: Manufacturing Cost vs ESEER for India.....	98
Figure B-7: Manufacturing Cost vs ESEER for Japan .....	99
Figure B-8: Manufacturing Cost vs ESEER for Korea .....	99
Figure B-9: Manufacturing Cost vs ESEER for Mexico .....	100
Figure B-10: Manufacturing Cost vs ESEER for Russia.....	100
Figure B-11: Manufacturing Cost vs ESEER for UAE.....	101
Figure B-12: Manufacturing Cost vs ESEER for USA.....	101
Figure D-1 Sensitivity of Cost of Conserved Electricity (CCE) to assumptions .....	105
Figure D-2 Sensitivity of Savings Potential to assumptions.....	105

## List of Tables

Table E-1 Average EERs of unducted split-packaged ACs in various economies in 2010-2011 (illustrative).....	5
Table E-2 Classic Efficiency Improvement Options and Corresponding Energy Savings .....	6
Table E-3 ESEER and Energy Savings at Economic and Technical Potential .....	8
Table 2-1: Different types of split-packaged units (split) air conditioners.....	16
Table 2-2: Different types of split-packaged units (split) air conditioners continued.....	17
Table 2-3: Multi-split packaged (multi-split) air conditioners .....	17
Table 2-4: Window or through-the-wall package air conditioners.....	18
Table 2-5: Single duct air conditioners .....	20
Table 2-6: Double duct air conditioners.....	21
Table 2-7: AHRI Directory of Certified Product Performance Classifications for Residential Central Air Con ditioners and Heat Pump.....	22
Table 2-8: Summary of Efficiency Improvement Options.....	24
Table 3-1 Percentage share of split packaged ACs of Room AC market.....	48
Table 3-2 Average Cooling (or Heating) Capacities in Various Economies.....	49
Table 3-3 Average EERs of unducted split-packaged ACs in various economies in 2010-2011 (illustrative)....	50
Table 3-4 Market share of inverter driven (or variable speed compressor) split packaged ACs.....	51
Table 3-5 Market Share of reversible (or cooling and heat pump) split packaged ACs .....	52
Table 4-1: Base Case Model Performance Characteristics .....	61
Table 4-2: Energy Savings for Individual Design Options Compared to the Base Case Model Used in the Eur opean Union .....	62
Table 4-3: Electricity Prices including Weighting (\$ per Kilowatt hour).....	65
Table 5-1 Room AC Sales by country.....	72
Table 5-2 ESEER and Energy Savings at Economic and Technical Potential .....	75
Table A-1: Summary of main outcomes from PCM Simulations & Experimentation.....	90
Table C-1 Econometric Studies of Direct Rebound for Residential Space Cooling.....	103



## Abbreviations and Acronyms

AC	Air conditioner
APF	Annual Performance Factor (used in Japan)
ASHRAE	American Society of Heating, Refrigerating and Air-Conditioning Engineers
Btu	British Thermal Unit
CAC	Central Air Conditioner
CCE	Cost of Conserved Electricity
CFCs	Chlorofluorocarbons
$C_D$	Coefficient of discharge
COP	Coefficient of Performance (expressed in W/W (SI units), or Btu/h/W (Imperial units). Multiply the SI value by 3.413 to express it in Btu/h/W) – often but not always used to refer to heating efficiency of heat pumps
DCV	Demand controlled ventilation
DEVap	Desiccant-enhanced evaporative air conditioning
DG-TREN	Directorate General for Energy and Transport
DG-ENTI	Directorate General for Enterprise and Industry
DOE	Department of Energy (United States of America)
EAC	Evaporating air conditioner
EC	European Commission
EER	Energy Efficiency Ratio (expressed in W/W (SI units), or Btu/h/W (Imperial units). Multiply the SI value by 3.413 to express it in Btu/h/W)
ESEER	European Seasonal Energy Efficiency Ratio, expressed in W/W (SI units)
EU	European Union
EuP	Energy-Using Products
FCC	Federal Communications Commission (US)
GHG	Green House Gases
GWP	Global Warming Potential
HVAC	Heating, Ventilating, and Air Conditioning
HCFC	Hydrochlorofluorocarbons
HP	Heat Pump
hp	Horsepower (US motors equivalent to kW)

HSPF	Heating Seasonal Performance Factor
kW	Kilowatt (EU motors equivalent to HP)
LRMC	Long Run Marginal Cost of Electricity Supply
NREL	National Renewable Energy Laboratory, Facility of the U.S. Department of Energy
ODP	Ozone depletion potential
PCM	Phase changing materials
PSC	Permanent split capacitor
SEAD	super-efficient equipment and appliance deployment
SEER	Seasonal Energy Efficiency Ratio (expressed in W/W (SI units), or Btu/h/W (Imperial units). Multiply the SI value by 3.413 to express it in Btu/h/W)
TEWI	Total Equivalent Warming Impact
TWh	terawatt hour
TXV	Thermostatic expansion valves
UEC	unit energy consumption
US	United States
VAC	Vapor compression air conditioner
VAV	Variable air volume air
VRF	Variable Refrigerant Flow

## Executive Summary

This report presents the results of an analysis, commissioned by the U.S. Department of Energy, of Air Conditioner (AC) efficiency in support of the Super-efficient Equipment and Appliance Deployment (SEAD) initiative.<sup>1</sup> The International Energy Studies group at Lawrence Berkeley National Laboratory in collaboration with Navigant Consulting Inc. performed the analysis. SEAD aims to transform the global market by increasing the penetration of highly efficient equipment and appliances.

SEAD partners work together in voluntary activities to: (1) “raise the efficiency ceiling” by pulling super-efficient appliances and equipment into the market through cooperation on measures like incentives, procurement, awards, and research and development (R&D) investments; (2) “raise the efficiency floor” by working together to bolster national or regional policies like minimum efficiency standards; and (3) “strengthen the efficiency foundations” of programs by coordinating technical work to support these activities.<sup>2</sup>

The objective of this analysis is to provide the background technical information necessary to improve the efficiency of ACs and to provide a foundation for the activities of SEAD participating countries. We find that even the best currently available technology offers large efficiency improvement opportunities (35% to 50% reduction in energy consumption from the market average) in most SEAD countries. The cost effective efficiency improvements range from 20% to 30% reduction in energy consumption based on a consumer perspective.

### Objective and Scope

The objective of this analysis is to identify potential Room AC efficiency improvements and their incremental costs, as well as to provide approximate global and country-specific estimates of total energy savings potential. The overarching goal is to provide relevant information to support design of policies and programs that will accelerate the penetration of super-efficient Room ACs.

This report addresses two categories of AC efficiency improvement potential: cost effective and technical. The efficiency improvements studied are those that are technically feasible, practical to manufacture, and feasible using components or technology that is already commercially available, and therefore could be realized in the short to medium term. The relationship between cost and efficiency improvement potential is presented in a consolidated fashion in terms of cost versus efficiency improvement and savings potential curves which can be used to estimate the technical and cost effective potential. Based on the information presented in the cost versus efficiency curve, the cost effective potential can be estimated at different levels of electricity costs which vary across consumer categories.

### Analysis Method and Data Sources

The analysis makes use of the energy efficiency incremental component costs and efficiency improvement options and corresponding energy efficiency data developed under the European Commission’s Ecodesign program Lot 10 study. This analysis has up-to-date cost and efficiency data

---

<sup>1</sup> As one of the initiatives in the Global Energy Efficiency Challenge, SEAD seeks to enable high-level global action by informing the Clean Energy Ministerial dialogue. In keeping with its goal of achieving global energy savings through efficiency, SEAD was approved as a task within the International Partnership for Energy Efficiency Cooperation (IPEEC) in January 2010.

<sup>2</sup> As of April 2011, the governments participating in SEAD are: Australia, Brazil, Canada, the European Commission, France, Germany, India, Japan, Korea, Mexico, Russia, South Africa, Sweden, the United Arab Emirates, the United Kingdom, and the United States. More information on SEAD is available from its website at <http://www.superefficient.org/>.

which was derived from extensive engagement with manufacturers and other industrial experts.

The base case is defined as a split fixed-speed room air conditioner model developed for the EU Lot 10 study, which is very typical of fixed speed split systems found around the world but is not the least efficient kind of product one can find on the market. Thus the analysis starts from a mid-market point for much of the world Room AC market<sup>3</sup>.

Once the base case is simulated the cost and energy efficiency of successive design changes are simulated such that all 1728 possible mutually exclusive options have been simulated for each economy. Local labor, supply chain markups, installation and maintenance costs, energy costs and capital costs are all adjusted for the local economy, based on a combination of sources such as literature, estimated factory gate costs, retail prices, expert contacts, and official statistics.

The approach outlined above generates cost versus efficiency curves for each economy, including manufacturer (or factory gate) costs and costs to the end user at each level of efficiency corresponding to a design change. The efficiency levels are calculated using climate specific and local hours of use data, generating different efficiency levels for the same model in different economies.

### Efficiency, Cost Effectiveness, and Energy Savings Metrics

While the efficiency at full load i.e. the energy efficiency ratio (EER) has been the most commonly used metric historically, most air conditioners only operate at full load for a small proportion of the time. The seasonal energy efficiency ratio (SEER) gives a better approximation of the annual average energy efficiency of a room air conditioner as SEER metrics are designed to account for performance during part load conditions occurring from time to time to produce a statistically representative metric of annual average energy efficiency. Currently such metrics are in place in Japan (called the Annual Performance Factor or APF) and the USA/Canada (known as the SEER). For this study we have chosen to use the new European Seasonal Energy Efficiency Ratio (ESEER), because unlike the other two metrics it also takes account of energy consumption in off and idle modes as well as energy used to keep crank cases warm in the heating system for reversible units and hence is likely to be more representative of performance of ACs when they are in use. Accordingly, all results in the report are reported in terms of the ESEER.

The cost-effectiveness metric used in the analysis presented here is the cost of conserved electricity (CCE), which is calculated by dividing the annualized incremental cost of a design change by the incremental energy saved by the design change per year. The design change is considered with respect to a design corresponding to the market average efficiency level in each economy.

Two kinds of costs of conserved electricity (CCE) are calculated as follows: a) CCE to the manufacturer, ( $CCE_m$ ), which considers the incremental cost of the higher efficiency model at the factory gate i.e. to the manufacturer and b) CCE to the consumer, ( $CCE_c$ ), which considers the incremental cost of the higher efficiency model to the consumer or end user. The former metric ( $CCE_m$ ) is lower than the latter ( $CCE_c$ ) as it does not include markups and installation costs.  $CCE_m$  could be used to measure the cost-effectiveness of a market transformation program such as a utility program offering an incentive to the

---

<sup>3</sup> In this study we consider window and unducted split packaged ACs under the general rubric of “Room ACs”. The global Room AC market is dominated by unducted split-packaged (known in the US as mini-split) air conditioners, with a trend towards these and away from window ACs in all the economies studied. Central air conditioners (US style ducted AC, packaged or split), are described in brief in Chapter 2, but are not the focus of this report. For a more detailed description of the different types of ACs, please see Chapter 2, while the trend toward split-packaged ACs is discussed further in Section 3.1.

manufacturer, while  $CCE_c$  would be used to measure the cost effectiveness a consumer incentive program or a minimum energy performance standard (MEPS) program.

Efficiency improvement options are cost effective if CCE is lower than the cost of electricity. Given that the cost of electricity varies across different stakeholders (i.e. consumers and utility), the cost effective level of efficiency improvement varies across stakeholders.

Finally, this analysis presents an estimate of the energy savings from Room ACs at various efficiency levels in 2020 from a Room AC market transformation program or policy implemented beginning in 2012, by using the earlier efficiency data and base sales data for each economy from the CLASP mapping report, BSRIA data, and the EU Ecodesign study. These data were extrapolated to 2020 using the model from McNeil et al. (2008). The sales forecast from Letschert (2009) was used for China. The metric used to report energy savings is Rosenfelds. One Rosenfeld is equivalent to annual energy savings of 3 Twh/year, i.e. about the energy generated by one medium-sized power plant.

## Summary of Findings

### Five Economies Constitute a Large Share of the Room AC Market Among Those Studied

Among the countries studied<sup>4</sup>, Room AC/Heat Pump sales are dominated by 5 economies (China, India, Brazil, Japan and the EU), with expected total 2014 sales of about 90% of the total market in the economies studied. Sales in the emerging economies are increasing fast, while sales in Europe and Japan are high and remain steady (Figure E1). The markets in the United States and Canada are dominated by large ducted AC systems, also sometimes referred to as Central ACs in the rest of the world rather than Room ACs.

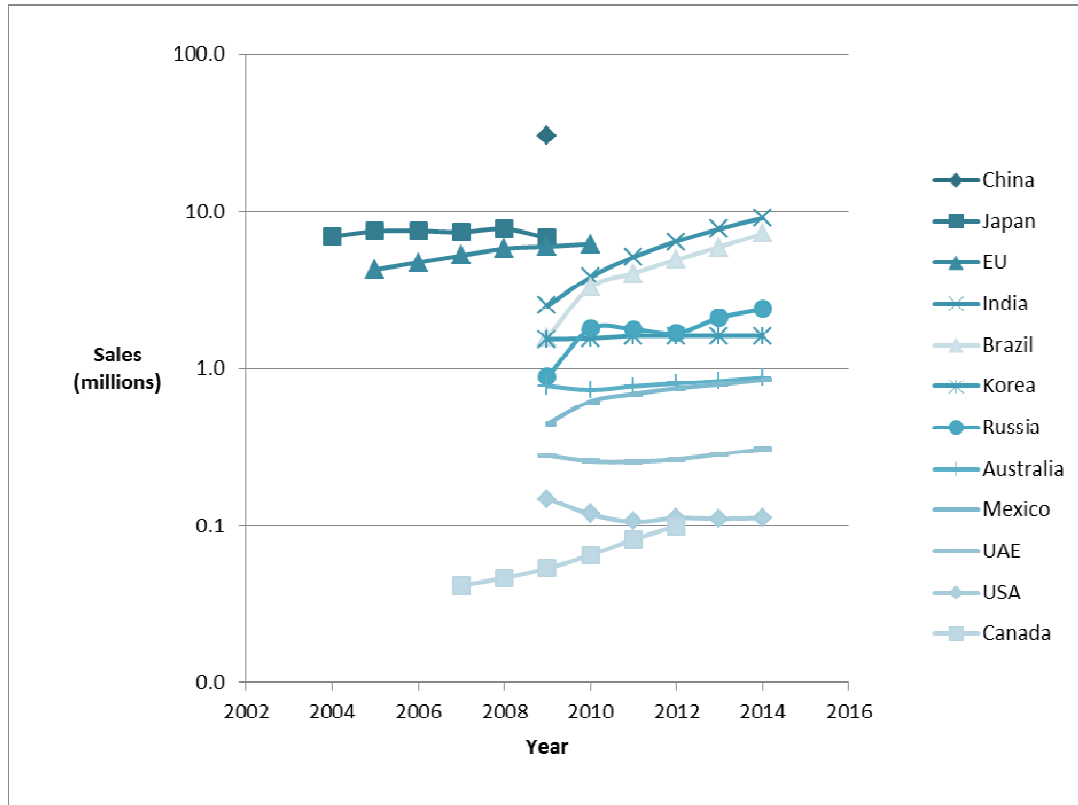

Figure E-1 Current and projected Room AC Sales in various countries (logarithmic scale) Source: BSRIA, and CLASP Mapping Report (Baillargeon, 2011)

<sup>4</sup> In this report we focus on the SEAD participating governments and China. As of April 2011, the governments participating in SEAD are: Australia, Brazil, Canada, the European Commission, France, Germany, India, Japan, Korea, Mexico, Russia, South Africa, Sweden, the United Arab Emirates, the United Kingdom, and the United States. More information on SEAD is available from its website at <http://www.superefficient.org/>

## Significant Potential for Efficiency Improvement Exists

The average energy efficiency of unducted split-packaged (known in the US as mini-split) air conditioners ACs/Heat Pumps which form the majority of global residential air conditioners in every country except the United States, varies from an average Energy Efficiency Ratio (EER) of 4.1 in Japan to an average of 2.69 in the UAE as shown in table E-1 below. The Japanese market has the most efficient air conditioners that are commercially available, with a maximum EER of 6.67 W/W, and an average of 4.1. We report efficiencies in table E-1 in EER terms even though the rest of the report uses ESEER, since the data available is reported using this metric.

Even though the data presented in Table E-1 are illustrative and cannot be compared directly *across countries* due to lack of availability of overlapping data sets and minor differences in test procedures, these data can be compared *within* each country studied. Table E-1 clearly and unequivocally show that there is a significant gap in efficiency terms between the best available split package AC in each economy and the average AC in that same economy. If the best available technology available globally is considered, it is even more evident that there is significant room for improvement in Room AC efficiency in all the economies, even if only ACs currently available on the market are considered.

Table E-1 Average EERs of unducted split-packaged ACs in various economies in 2010-2011(illustrative)<sup>5</sup>

Country	EER (W/W)		
	Min	Max	Average
Australia	2.67	4.88	3.16
Brazil	2.92	4.04	3.19
Canada	2.14	4.33	3.6
China	2.9	6.14	3.23
EU	2.21	5.55	3.22
India	2.35	3.6	2.8
Japan	2.37	6.67	4.1
Korea	3.05	5.73	3.78
Mexico	2.42	4.1	2.92
Russia	2.5	3.6	2.79
South Africa	2.28	5	2.91
UAE	2.14	3.22	2.69
USA	-	4.6	3.04

Source: Catalog searches, IEA 4E M&B 2010, Baillargeon, 2011

---

<sup>5</sup> This data should be treated as illustrative as no overlapping datasets were available to cross-check these data points. Data shown in table E-1 are based on a) samples obtained from catalog searches in Brazil, Canada, Mexico, Russia, South Africa and the UAE, b) from the IEA 4E Mapping and Benchmarking Analysis for Australia c) from the CLASP Mapping Report for China, EU, India, Japan and the USA, and d) from the IEA 4E Mapping and Benchmarking Analysis for Korea. (IEA 4E M&B 2010, Baillargeon, 2011)

## Summary of Efficiency Improvement Options

Various options to improve air conditioner efficiency exist, including “classic options” such as increasing heat exchanger size/efficiency, variable speed and efficient compressors, efficient fans, and thermostatic and electronic expansion devices. In Table E-3 below, we summarize some of the more common options, and the corresponding energy savings (%) compared to the base case. The range shown in Table E-2 indicates the range of energy savings possible from a small incremental efficiency improvement(min), or the best technology available (max).

**Table E-2 Classic Efficiency Improvement Options and Corresponding Energy Savings<sup>6</sup>**

Option	Description	% improvement from base case	
		Min	Max
Efficient Heat Exchanger	high efficiency microchannel heat exchangers, larger sized heat exchangers	9.1%	28.6%
Efficient Compressors	two-stage rotary compressors, high efficiency scroll compressors with DC motors	6.5%	18.7%
Inverter/Variable Speed	AC, AC/DC or DC inverter driven compressors	20%	24.8%
Expansion Valve	Thermostatic and electronic expansion valves	5%	8.8%
Crankcase Heating	Reduced crankcase heating power and duration	9.8%	10.7%
Standby load	Reduced standby loads	2.2%	2.2%
Total/cumulative <sup>7</sup>		60 %	72%

If all the efficiency improvement options shown in Table E-2 above are employed, then the higher efficiency Room AC could save between 60-72% of energy compared<sup>8</sup> to the base case model in the various economies studied, varying by usage and climate in the various economies studied.

---

<sup>6</sup> The energy savings figures presented here are representative of conditions in Europe.

<sup>7</sup> Note: Cumulative efficiency improvement is lower than a simple addition as the options are not mutually exclusive, i.e. improvement using one option reduces the baseline energy consumption to which the next efficiency improvement option is applied. Also, the improvements due to variable speed drives are climate and usage dependent.



**Efficiency Improvement to ESEERs between 4.2- 7.44 W/W is Cost Effective Leading to Savings Potential of over 63 Rosenfelds<sup>9</sup>**

Applying the efficiency improvement options discussed earlier to the base case model, and calculating the incremental cost to the consumer of conserved electricity as described in chapter 4 of this report, we present the resulting cost versus efficiency curve in Figure E-2 below.

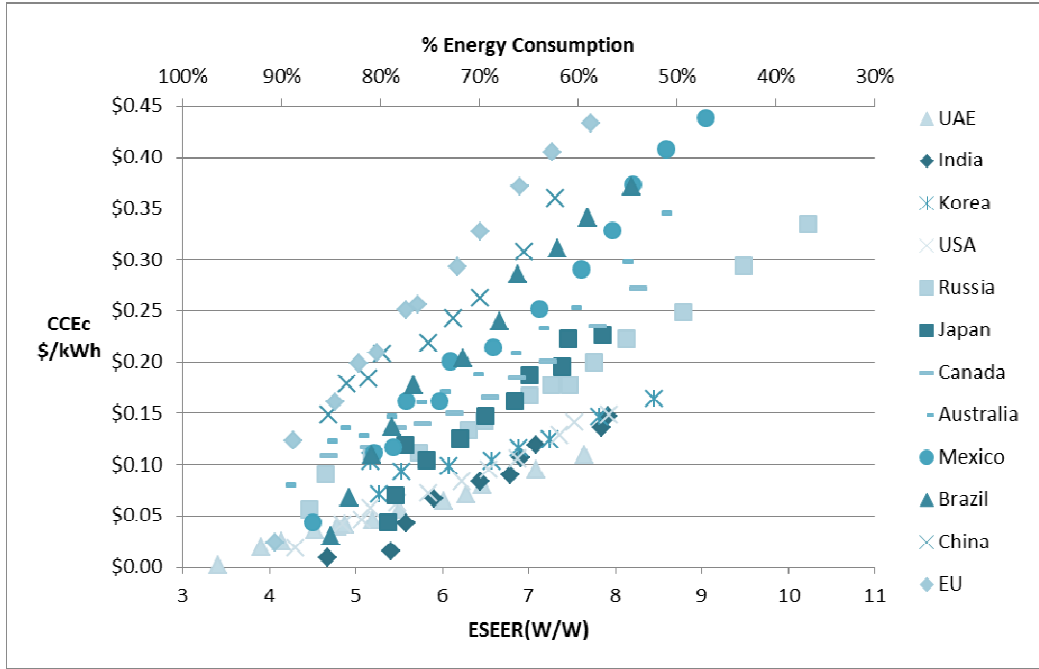

**Figure E-2 Cost to Consumer of Conserved Electricity (CCEc) Versus Room AC Efficiency for Various Economies**

In economies with a higher cost of capital (i.e. discount/interest rates) such as Brazil, or low hours of use, higher efficiency ACs carry a larger cost of conserved electricity, when compared to India or UAE. For countries such as Japan where ACs are used for both heating and cooling, and India or UAE, where ACs are used for many hours annually, very high ESEERs are attainable at low cost per unit of electricity saved. Significant energy savings are cost effective in most of the economies studied, as further shown in Table E-3 below.

<sup>9</sup> In line with Koomey et al. 2010, we use the unit of Rosenfeld for denoting energy savings. One Rosenfeld=3TWh/year, or approximately one 500MW (i.e.medium power plant).

A	B	C	D	E	F	G	H
Country	Tariff \$/kWh	Market Average ESEER	Economic Potential ESEER (W/W) @ Tariff = CCEc	Technical Potential Max ESEER (W/W)	2020 Energy Savings @ Economic Potential (Rosenfelds)	2020 Energy Savings @ Technical Potential (Rosenfelds)	2020 CO2 savings @ Technical Potential (tons/year)
Australia	0.10	4.03	4.48	8.55	0.35	2	4
Brazil	0.19	4.05	5.67	8.83	6	10	3
Canada	0.08	4.58	4.54	8.26	0	0.24	0.1
China	0.19	4.11	5.19	7.30	16	33	99
EU	0.19	4.09	5.00	8.33	11	30	32
India	0.08	3.56	5.55	7.91	19	29	78
Japan	0.22	5.21	7.44	7.85	8	9	11
Korea	0.07	4.80	5.33	8.45	1	4	5
Mexico	0.08	3.71	4.45	9.74	0.15	1	1
Russia	0.05	4.20	4.20	10.23	0	4	4
UAE	0.07	3.46	6.24	7.64	2	2	3
USA	0.11	3.87	6.80	8.00	0.2	0.24	0.4
Total					64	123	241

**Table E-3 ESEER and Energy Savings at Economic and Technical Potential**

In the above table E-3, we present the following information:

- Column B: representative consumer tariffs for the economies studied.
- Column C: the approximate market average ESEER converted from the EER values reported in chapter 3.
- Column D: the economic or cost effective potential in terms of ESEER i.e. at efficiency levels where cost of conserved electricity equals the tariffs in column B.
- Column E: the total or technical potential in ESEER terms, i.e. the ESEER possible by deploying the best available technology in the climate and seasonal conditions of the respective economies.
- Column F: the 2020 annual energy savings potential from Room AC efficiency improvement in Rosenfelds (3TWh/yr), assuming that the corresponding market transformation program goes into effect at the efficiency level corresponding to column D and transforms 100% of the market. i.e. a standard corresponding to column D.
- Column G: the 2020 annual energy savings potential from Room AC efficiency improvement in Rosenfelds (3TWh/yr), assuming that the corresponding market transformation program goes into effect at the level corresponding to column E and transforms 100% of the market. i.e. the potential available for a labeling or incentive specification corresponding to column E.
- Column H: the 2020 annual CO<sub>2</sub> savings potential from Room AC efficiency improvement assuming that the corresponding market transformation program goes into effect at the level corresponding to column E and transforms 100% of the market. i.e. the potential available for a

labeling or incentive specification corresponding to column E.

The total 2020 energy savings potential from standards that is cost effective from a consumer perspective is about 64 Rosenfelds, i.e. Equivalent to 64 medium sized power plants (or 192 TWh/year), while the total technical potential is about 123 Rosenfelds, i.e. about 123 medium sized power plants(or 369 TWh/year). (Kooomey et al. 2010)

If the costs of peak power, backup generation or power outages are included in the consideration of cost-effectiveness, due to the high peak coincidence of Room AC use, the ESEER levels that would be considered to be cost effective would be even higher than those shown in column D, along with correspondingly higher savings to those bearing these costs (i.e. taxpayers, other ratepayers etc.)

### Low Global Warming Potential (GWP)/ Ozone Depletion Potential (ODP) Refrigerants Can Have a Cost and Efficiency Impact

Through the Montreal Protocol and related processes, the Room AC industry is developing lower GWP refrigerants to phase out high GWP, HFC-based refrigerants. This next generation refrigerant development process has many tradeoffs with cost and energy efficiency, thus all three issues (cost, efficiency, and low ODP/GWP) need to be considered when designing market transformation programs.

### Insights for designing market transformation programs

Based on the analysis presented in this report, Room AC energy efficiency improvement offers significant opportunity for cost-effective energy efficiency improvement. We provide an example of how the information presented in the form of a cost curve can be used in designing efficiency market transformation programs such as MEPS and incentives

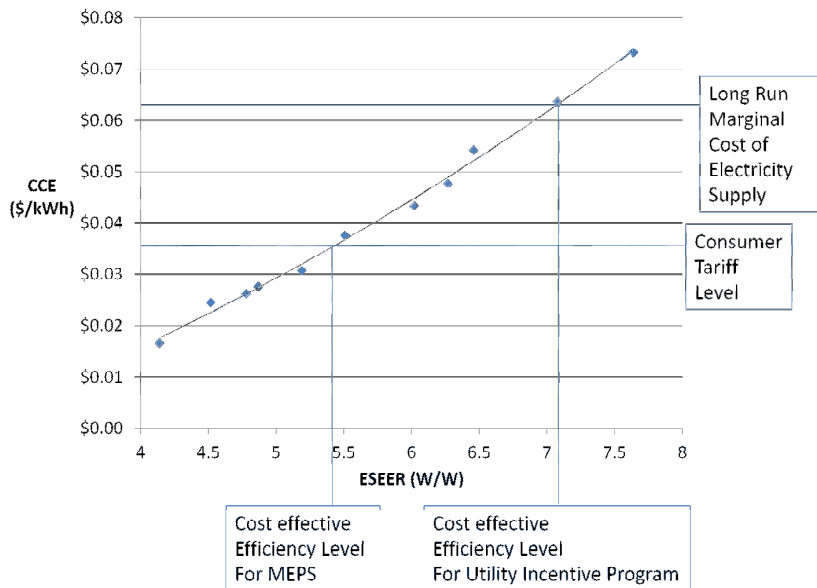

**Figure E-3 Cost Curves and Market Transformation Programs**

If the criteria for setting minimum energy performance standards (MEPS) are that efficiency improvements targeted should be cost effective from a consumer perspective, then the level of efficiency improvement that can be targeted will be where CCE is less than or equal to the consumer tariff (see Figure E-2).

In several cases, consumer tariffs are lower than the cost of supply during the time when ACs are used. In such instances, efficiency levels targeted by financial incentive programs could be where CCE is less than or equal to cost of supply during those times (long run marginal cost of supply at the time when the ACs are used).

Metrics of cost effectiveness that are typically used for designing efficiency programs could be expanded beyond consumer cost-effectiveness perspective in several other ways. For example, such metrics could account for subsidies, the cost of peak power, the costs of backup generation, or the costs of power outages. The cost effectiveness data presented in Chapters 4 and 5 of this report could be used to design programs with such expanded considerations of cost-effectiveness, and therefore correspondingly target higher efficiency levels. While expanded metrics could also be used across multiple product categories, such expanded metrics are particularly relevant for AC use due to the high contribution of ACs to peak loads, power outages, and backup generation.

Note that the analysis presented in this report provides initial estimates of costs for various levels of efficiency improvements and is likely to need further refinement in order to be used for program design purposes.

## Chapter 1 Introduction

The U.S. Department of Energy (DOE) commissioned the International Energy Studies group at Lawrence Berkeley National Laboratory to undertake this technical analysis of room Air Conditioner (AC) efficiency in support of the Super-efficient Equipment and Appliance Deployment (SEAD) initiative. The subsections below describe SEAD, the objective, scope and data sources for this project, and the organization of the remainder of this report.

### 1.1 Super-Efficient Equipment and Appliance Deployment Initiative (SEAD)

The SEAD initiative aims to transform the global market by increasing the penetration of highly efficient equipment and appliances. SEAD is a government initiative whose activities and projects engage the private sector to realize the large global energy savings potential from improved appliance and equipment efficiency. SEAD seeks to enable high-level global action by informing the Clean Energy Ministerial dialogue as one of the initiatives in the Global Energy Efficiency Challenge. In keeping with its goal of achieving global energy savings through efficiency, SEAD was approved as a task within the International Partnership for Energy Efficiency Cooperation (IPEEC) in January 2010.

SEAD partners work together in voluntary activities to: (1) “raise the efficiency ceiling” by pulling super-efficient appliances and equipment into the market through cooperation on measures like incentives, procurement, awards, and research and development (R&D) investments; (2) “raise the efficiency floor” by working together to bolster national or regional policies like minimum efficiency standards; and (3) “strengthen the efficiency foundations” of programs by coordinating technical work to support these activities.

Although not all SEAD partners may decide to participate in every SEAD activity, SEAD partners have agreed to engage actively in their particular areas of interest through commitment of financing, staff, consultant experts, and other resources. In addition, all SEAD partners are committed to share information, e.g., on implementation schedules for and the technical detail of minimum efficiency standards and other efficiency programs. Information collected and created through SEAD activities will be shared among all SEAD partners and, to the extent appropriate, with the global public.

As of February 2013, the governments participating in SEAD are: Australia, Brazil, Canada, the European Commission, France, Germany, India, Japan, Korea, Mexico, Russia, South Africa, Sweden, the United Arab Emirates, the United Kingdom, and the United States. More information on SEAD is available from its website at <http://www.superefficient.org/>.

### 1.2 Objective and Scope

The objective of this analysis is to identify potential Room AC efficiency improvements and their incremental costs, as well as to provide initial global and country-specific estimates of total energy savings potential. The overarching goal is to provide relevant and appropriate information to support design of appropriate policy programs that will accelerate the penetration of super-efficient Room ACs.

This report sets out the main characteristics of residential air conditioning systems in use internationally and seeks to assess and report the energy saving options for room air conditioners across principal economies namely: China, Europe, India, Japan and the USA. It is adapted to other economies by application of local cost factors. The report builds on the analysis presented as part of the US Department of Energy’s recent rulemaking and Max Tech Analysis and discusses additional elements not originally considered including: free cooling for window/louvered air conditioners, smart grid coupling, occupancy sensors, variable speed compressors, blower and fan efficiency improvements, effect of new refrigerants, as well as other efficiency improvement options currently being considered worldwide. Moreover, alternative electromechanical cooling options that may be applicable in some climates and economies such as evaporative cooling, phase change materials and night cooling storage technologies, are also outlined in Appendix A.

### 1.3 Analysis Method and Data Sources

The energy efficiency simulation model used in this analysis is the same one used for the EU's Ecodesign Lot 10 study and is an adapted version of the Oak Ridge National Laboratory model that has previously been applied to similar analyses in the USA for the USDOE.

The analysis makes use of the energy efficiency incremental component costs and efficiency improvement options and corresponding energy efficiency data developed under the European Commission's Ecodesign program Lot 10 study. This analysis has been recently completed and it thus has up-to-date cost and efficiency data which was derived from extensive engagement with manufacturers and other industrial experts.

The base case is defined as a split fixed-speed room air conditioner model developed for the EU Lot 10 study, which is very typical of fixed speed split systems found around the world but is not the least efficient kind of product one can find on the market. Thus the analysis starts from a mid-market point for much of the world Room AC market.

Once the base case is simulated the cost and energy efficiency of successive design changes are simulated such that all 1728 possible mutually exclusive options have been simulated for each economy. Local labor, supply chain markups, installation and maintenance costs, energy costs and capital costs are all adjusted for the local economy, based on a combination of sources such as literature, estimated factory gate costs, retail prices, expert contacts and official statistics.

The approach outlined above generates cost versus efficiency curves for each economy, including manufacturer (or factory gate) costs and costs to the end user at each level of efficiency corresponding to a design change. The efficiency levels are calculated using climate specific and local hours of use data, generating different efficiency levels for the same model in different economies.

Finally, this analysis presents an estimate of the energy savings from Room ACs at various efficiency levels in 2020 from a Room AC market transformation program or policy implemented in 2012, by using the earlier efficiency data and base sales data for each economy from the CLASP mapping report, BSRIA data, and the EU Ecodesign study. These data were extrapolated to 2020 using LBNL's Bottom Up Energy Analysis System (BUENAS) model (McNeil et al. 2013) . The sales forecast from Letschert (2009) was used for China.

### 1.4 Organization of this Report

The remainder of this report is organized as follows:

**Chapter 2, *Engineering Analysis***, discusses various types of Air Conditioning systems and opportunities to increase AC efficiency for the most common type of Room ACs

**Chapter 3, *Market and Energy Consumption Trends*** discusses the current efficiency levels, sales data and energy consumption trends in the Room AC market.

**Chapter 4, *Economic Analysis***, discusses the costs and corresponding energy savings of the classic efficiency improvement options presented in Chapter 2, and presents the results of cost-effectiveness analysis based on the cost of the conserved energy (CCE).

**Chapter 5, *Estimates of Energy Savings Potentials***, presents AC energy and CO<sub>2</sub> savings potentials

**Chapter 6 *Summary and Conclusions***, summarizes the previous chapters and offers conclusions and suggestions relevant for policymakers.

Several appendices provide supporting information for this analysis as follows:

**Appendix A** lists climate specific efficiency improvement options that can also lead to substantial savings

in Room AC energy consumption.

*Appendix B* presents country-specific manufacturing cost curves at various efficiency levels for the classic efficiency improvement options presented in Chapter 2.

*Appendix C* presents a discussion of the rebound effect in air conditioners.

*Appendix D* presents a sensitivity analysis of the cost effectiveness analysis and energy savings potential to various assumptions.

## Chapter 2 Engineering Analysis

Residential air conditioning equipment is designed to provide space cooling in households but the same equipment can also often be used to provide heating depending on the design. International comparisons are complicated by the fact that the type of systems commonly used in North America are rarely used anywhere else in the world, whereas the most common international solutions are only used in small quantities on the US market. In addition, the test procedures used to measure cooling capacity and to rate the efficiency of a unit can also vary from one economy to another which further complicates attempts to benchmark the energy performance of equipment at an international level. Nonetheless, there are sufficient similarities for some meaningful comparisons to be made and opportunities to be identified.

### 2.1 Types of Residential Air Conditioner

The term “Residential Air Conditioner” can be applied to any air conditioning system that is applied to household cooling. In practice, as air conditioners are a type of heat pump i.e. they use energy to move heat from one place to another, and in consequence they can often also be operated in reverse to provide space heating. Systems with such a function are known as “reversible” units but will be referred to as either reversible or heat pumps from here on. The other main distinctions between air conditioning systems are:

- whether they are ducted or not, which means whether they are designed to be connected to separately supplied ducting which is used to distribute space conditioned air around a building. Central air conditioners are ducted and non-central (including room air conditioners) are not ducted
- whether they use air or water as the distribution medium for cooling.
- whether their condenser (outside unit) is designed to be thermally coupled with the outside air, ground or water as the external heat reservoir
- whether they use the vapor compression cycle or an alternative refrigeration cycle such as absorption cooling and evaporative cooling

This study seeks to present the conventional options for increasing the energy efficiency for the most commonly used systems, namely those using vapor compression cycles without evaporative cooling and that have external heat transfer with the air (not the ground or water). It then continues by evaluating the more exotic and climate-specific solutions for increasing the energy efficiency of these systems, which are presented in Appendix A. It should be noted that in several instances the less common air conditioning strategies are the most energy-efficient and thus energy saving policies are needed which encourage the adoption of the optimal solution within each specific application context, in addition to encouraging the adoption of higher efficiency systems within each product class.

In the remainder of this section, the various types of room air conditioners are presented using the most common international commercial product classifications, namely:

- Split-packaged units (referred to as mini-split or duct-free split in the US)
- Multi split packaged units
- Single packaged units (referred to as window air conditioners in Europe, but also package terminal air conditioners in the US)
- Single duct units
- Double duct units
- Central air conditioners (US style ducted AC, packaged or split)
- Residential chillers (mini chillers)



All the systems listed here may be reversible when equipped with a four-way valve, which allows the air conditioner to operate as a heat pump. This is a very common feature and for some classes of residential air conditioners they predominate in the market compared to cooling only systems. It is thus overly restrictive to consider the cooling-only performance of heat pumps in isolation of their heating performance when making energy efficiency comparisons.

### **Split-packaged units (including mini-splits)**

Split-packaged units are defined as a factory assembly of components from a refrigeration system fixed on two or more mountings to form a matched unit. This appliance type has two packages (one indoor and one outdoor unit) connected by a pipe that transports the refrigerant. The indoor unit includes the evaporator and fan and the outdoor unit includes the compressor and condenser. Note that the indoor unit(s) can be ducted or non-ducted.

- Non-ducted indoor units may be either fixed – whether mounted high on a wall, floor-mounted or, as ‘cassette’, ceiling-suspended, built-in horizontal or built-in vertical – or, mobile. The outdoor unit may be either fixed or mobile
- Ducted indoor units can deliver cool air into several rooms or into several ports within a single room

Standard split-packaged (mini split) air conditioners dominate air conditioner sales in most parts of the world including Asia and Europe. They are among the most energy efficient options for room air conditioning.

It should also be noted that in economies outside North America split-packed AC (mini splits) are considered to be a type of room air conditioner because they only cool a single room whereas in North America they are considered to be a type of central air conditioner both for the purposes of testing and within energy efficiency regulations. As a consequence, in the USA they are tested in the same manner and are subject to the same regulatory requirements as other types of central air conditioning equipment (see section on central air conditioners below).

Table 2-1: Different types of split-packaged units (split) air conditioners







Type of Air Conditioner	Operating Schemes	Examples
<p>Non ducted fixed split-packaged unit (split system)</p>		<p>Indoor unit: Wall mounted</p>   <p>Indoor unit: Console or ceiling suspended</p>  <p>Indoor unit: Cassette</p> 

Table 2-2: Different types of split-packaged units (split) air conditioners continued

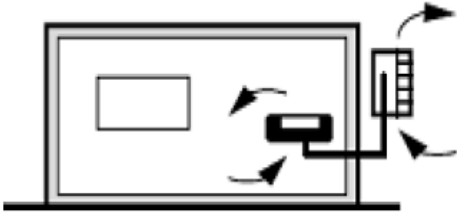
Type of Air Conditioner	Operating Schemes	Examples
Non-ducted split-packaged unit with mobile indoor unit (mobile split)		<p>Mobile indoor unit</p> 
Ducted split-packaged unit (Ducted split system)		<p>Ducted built-in horizontal indoor unit</p> 

Source: (EuP, 2009)

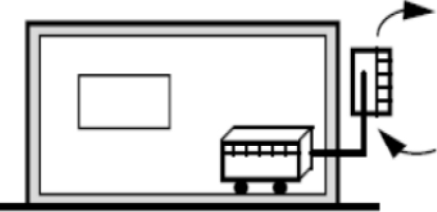
**Multi-split packaged units (multi split)**

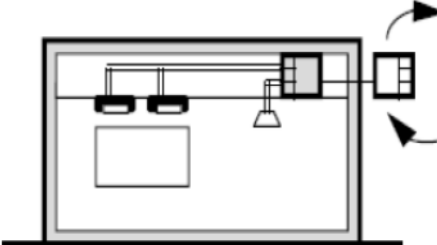
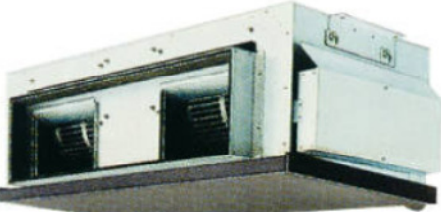
Multi-split packaged units contain numerous interior units (typically up to 4 units) connected to a single exterior unit. These units are similar to split interior and exterior units. Indoor units can also be ducted or non-ducted.

Table 2-3: Multi-split packaged (multi-split) air conditioners

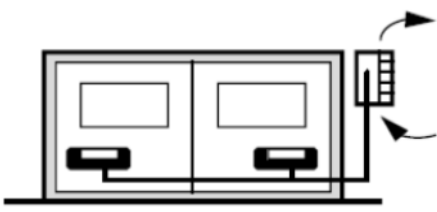
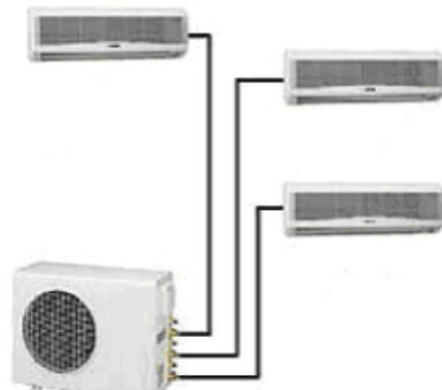
Type of Air Conditioner	Operating Schemes	Example
Multi-split-packaged units		

Source: (EuP, 2009)

Multi-split systems should not be confused with VRF systems (Variable Refrigerant Flow) which is the

name generally adopted to avoid using Daikin’s trade name, Daikin VRV®, of variable refrigerant volume.

In both multi-split units and VRFs, every inside unit is connected to the single outside unit. However in VRF systems, the refrigerant flow to the inside units can each be individually controlled and customized for the desired conditions at the inside unit, this is not the case for multisplit units, which are typically designed for a single thermal zone with similar heat gains/losses.



**Single-packaged units**

Single-packaged units, commonly referred to as ‘through-the-wall’ or ‘window’ air conditioners (these are called room air conditioners in the USA), are strictly defined as a factory assembly of components from a refrigeration system fixed on a common mounting to form a single unit system.

This equipment is composed from a single package, one side of which is in contact with the outside air and releases heat outside, while the other side provides direct cooling to the air inside. The two sides of the appliance are separated through a dividing wall, which is insulated to reduce heat transfer between them. Single-packaged units often fit above or below a window or above a door. A key distinction is whether they have louvered sides (designed for window opening installation) or not (designed for an opening in the exterior wall installation).

The wall type units which include an air damper to control air change (thus also supplying air change) are called package terminal air conditioners. Window and wall single packaged units are an older technology than split-packaged room air conditioners. They used to dominate the room air conditioner market but have now generally given way to split packaged systems in parts of the world that don’t use central air conditioning. Nonetheless they still comprise an important part of the air conditioner market.

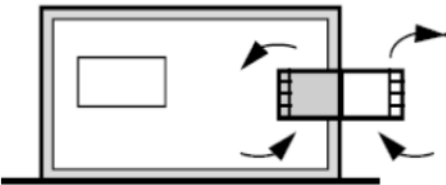
**Table 2-4: Window or through-the-wall package air conditioners**

Type of Air Conditioner	Operating Schemes	Example
Single-packaged-unit, through the wall		



Source: (EuP, 2009)

**Single-duct units**

Single-duct units are room air conditioning appliances whose condenser emits hot air via a duct to the exterior: air that used to cool the condenser is taken inside the room and then rejected outside. These systems are generally mobile (i.e. can be readily moved), but in order to operate them they must be located close to a window or door through which the duct can expel the hot air. In principle, a dedicated hole should be made in the envelope just for the appliance, as the use of doors and windows for the duct allows hot air to infiltrate; however, in practice they are rarely used in that way. As a consequence it is a challenge to properly account for the thermal leakage of such ducting when measuring the energy performance of a single-duct system and there are concerns about the validity of the current testing approaches used in various parts of the world for this appliance type. Single-duct appliances are generally low cost and inefficient devices that tend to be used by end-users with very intermittent space conditioning needs. They are quite common in Europe but less so in parts of the world with more regular

air conditioning needs. As these appliances are relatively inefficient and have low sales in the world market they will not be considered further in this study.

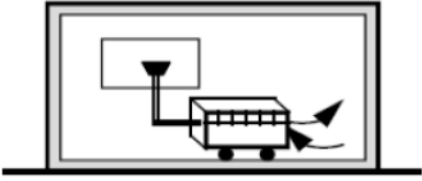
Table 2-5: Single duct air conditioners

Type of Air Conditioner	Operating Schemes	Example
Single duct air conditioner		

Source: (EuP, 2009)

**Double-duct units**

Double-duct units are seen as the “cousin” of the single duct air conditioner and are an evolution of it. There are two main types of double-duct unit. The first is very similar to a single duct except that a second hole at the condenser enables air for the condenser to be drawn from the outside, this minimizes outside air infiltration into the room to be cooled. The second type is similar but of a more permanent installation through the wall and in that case, the two ducts may be concentric. These products are not thought to be very common in any market at present and as they offer no appreciable energy saving option compared to other designs will not be considered further in this study.

Table 2-6: Double duct air conditioners

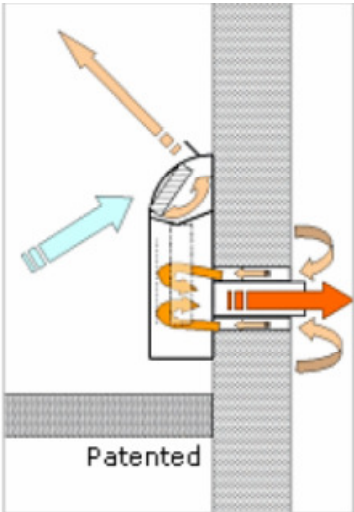
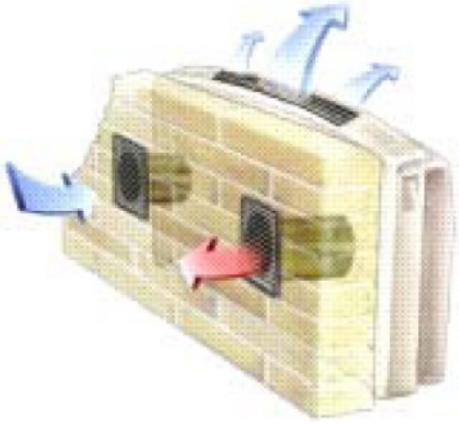
Type of Air Conditioner	Operating Schemes	Example
Double duct air conditioner (through the wall installation)		

Source: (EuP, 2009)

**Residential central air conditioners**

The type of residential central air conditioners that are most common in the United States and Canada are seldom used in other parts of the world, where “mini” split-packaged and other types of room air conditioning system dominate. The term “central air conditioners” refers to air conditioners that distribute cool air around the home via a ducted central air distribution system. The air conditioning units used may be either packaged air conditioners with a duct to blow cold air into the central air system of the residence, or a split system with a cooling coil placed in the air stream of the centralized air system, that can be delivered with or without a fan. Figure 2-1 shows a schematic illustration of a split central air conditioner.

The key distinctions between central air conditioners and the internationally preponderant split-packaged air conditioners are that:

- the former are designed to cool a whole house and hence tend to have much greater cooling capacities
- the split-packaged systems cool and distribute the air directly within the room where the indoor unit is and thus do not suffer the duct losses that are common to central air distribution systems furthermore they generally cool the space where an occupant is situated rather than the entire building and hence tend to use less energy

Central air conditioners are the dominant home cooling system in the USA. They are installed in almost all new homes and are present in over 60% of all households. They also dominate residential energy use such that while room air conditioners were thought to use about 12 TWh of final electricity demand in 2010 central air conditioners were thought to use 215 TWh. Improving the energy efficiency of these systems and/or identifying viable higher efficiency alternatives is the main means of improving the efficiency of residential AC equipment in the US.

## Central Air Conditioner on a Forced Air System

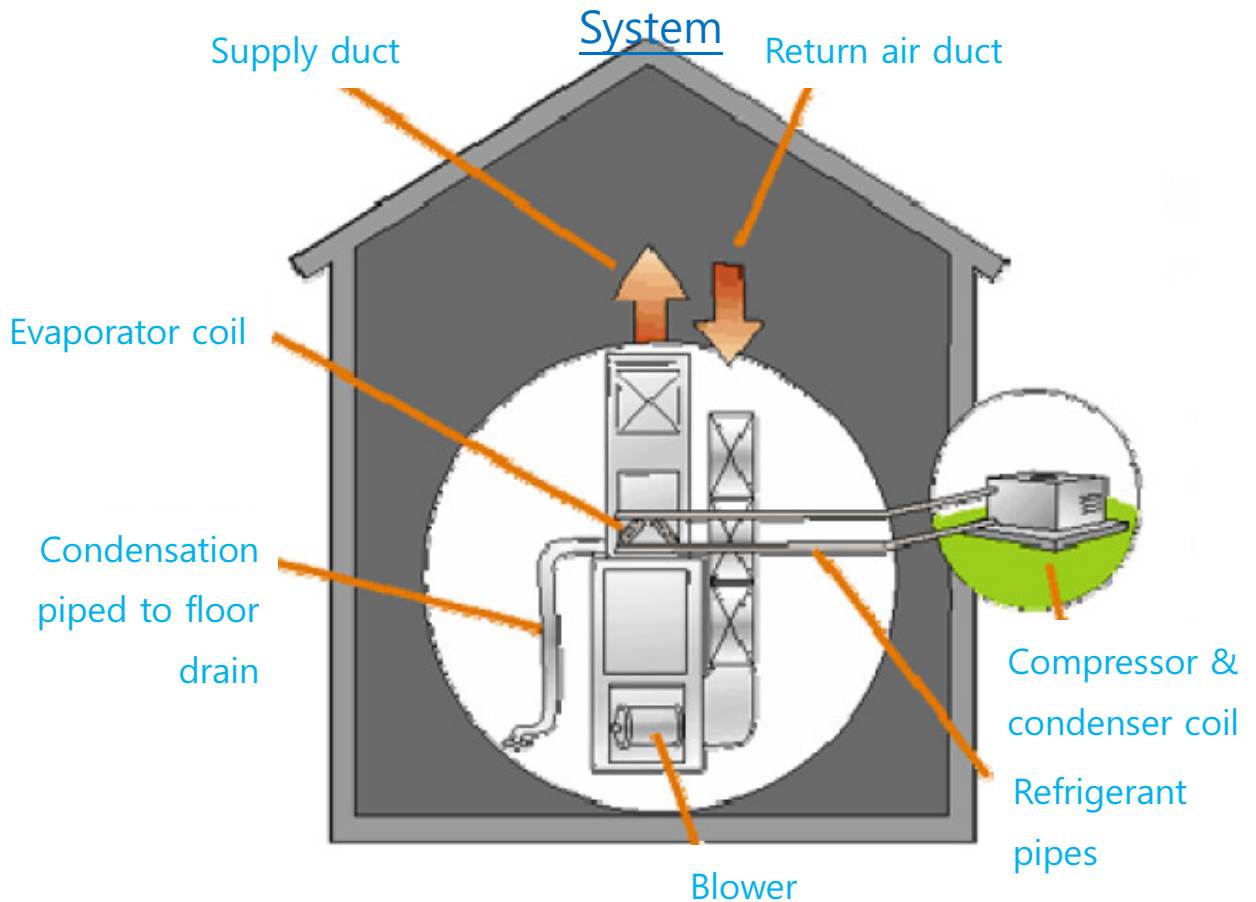

Figure 2-1: Central air conditioner of the split type

Source: (THA, 2011)

Central AC and heat pump systems in the US come in a variety of sub-types.

**Table 2-7: AHRI Directory of Certified Product Performance Classifications for Residential Central Air Conditioners and Heat Pump**

DOE Product Class	AHRI Classifications*
Split system air conditioner	RCU-A-AC RCU-A-CB RCU-A-CB-O RCUY-A-CB RCUY-A-CB-O RC-A
Split system heat pumps	HRC-A-C HRC-A-CB HRCU-A-C HRCU-A-CB



DOE Product Class	AHRI Classifications*
	HRCU-A-CB-O HORC-A-C HORCU-A-C HORCU-A-CB
Single package air conditioners	SP-A SPY-A
Single package heat pumps	HSP-A
Small duct, high velocity systems	SDHV-RCU-A-CB SDHV-HRCU-A-CB SDHV-HORCU-A-CB
Space constrained products – air conditioners**	TTW-RCU-A-C TTW-RCU-A-CB
Space constrained products – heat pumps**	TTW-HRCU-A-C TTW-HRCU-A-CB

\*The classifications listed are only those with products available in the AHRI Directories of Certified Product Performance for central air conditioners and heat pumps. For more information on AHRI classifications and their definitions, visit [www.ahridirectory.org/ahriDirectory/pages/fieldHelp.aspx?program=AC&controlID=ariType](http://www.ahridirectory.org/ahriDirectory/pages/fieldHelp.aspx?program=AC&controlID=ariType) for air conditioners, or [www.ahridirectory.org/ahriDirectory/pages/fieldHelp.aspx?program=HP&controlID=ariType](http://www.ahridirectory.org/ahriDirectory/pages/fieldHelp.aspx?program=HP&controlID=ariType) for heat pumps.

\*\*The AHRI Directory of Certified Performance did not list any space constrained products as of March 16, 2009. However, after January 23, 2010 (which is after the effective date for this rulemaking) the Through-the-wall equipment classes will expire, at which time, they will become part of the space constrained product classes.

Source: (TSD, 2010a)

### Chiller based systems

Mini chillers used for residential applications produce cold water which is circulated within the house to feed cool ceilings, floors, panels or fan coils (water to air heat exchangers). In cool ceilings and panels, the heat transfer is principally by radiation although convection also has a role. When fan coils are used the heat transfer is purely convective. This centralized system, traditionally applied within the tertiary building sector, can now also to be found in dwellings, although it is not yet very common. As water is a superior heat transfer fluid to air these systems are inherently more energy-efficient than air conditioning systems based on the centralized distribution of chilled air. In addition, the use of chilled radiative panels produces more efficient cooling than the use of liquid-cooled fan coils, this is partially due to the required temperature reduction of the working fluid being less; however, a large surface is required in each space which risks the formation of condensation in humid climates unless a dehumidification system is also installed.

## 2.2 Water-cooled Systems

In principle water can be used to cool the refrigerant in all the air conditioner types described above. However, in practice water-cooled systems are not commercially available for single-duct or double-duct systems and are still very uncommon for split and multi-split systems. In Europe water-cooled mini-chillers are on the market for use within geothermal and aquifer heat pump systems and are becoming quite prevalent in some European countries (notably Sweden and Switzerland). Among water-cooled single-package air conditioners the majority are sold for use within larger air conditioning systems called “Water Loop Heat Pump systems” which are used for commercial premises and thus will not be considered further in this study.

For water-cooled air conditioners which are not part of a Water Loop Heat Pump system, the water can originate from the water mains, a natural source or be supplied in a closed circuit system. In the first case, the heated water is not conserved (i.e. it is returned into the sewers), in the second case the heated water is rejected back into the source and in the third case, the heated water is conserved and is cooled using a heat exchanger (e.g. a dry cooler or cooling tower<sup>10</sup>). Therefore, in the two first cases, the water used to condense the refrigerant is taken from either a natural source or the public water supply but is not conserved and thus implies higher water bills. In the third case, the water used to condense the refrigerant is recycled either totally or partially in the cooling tower and the water bills are thus lower. In principle the water used in air conditioning systems does not need to be potable but this is rarely an option in practice. As a result, any environmental impact assessment should also account for the water used in the air conditioning system.

## 2.3 Opportunities to Increase Air Conditioner Efficiency

### 2.3.1 Classic Component Options Across all Economies

In this section we describe possible efficiency gains from classic components of residential air conditioners such as: compressors, fans, heat exchangers, expansion devices, and refrigerant fluids. We also investigate improvements in the thermodynamic cycle in this section. These are summarized in Table 2-8 below.

**Table 2-8: Summary of Efficiency Improvement Options**

Option	Description	% improvement from base case		Barrier to Implementation
		Min	Max	
Efficient Heat Exchanger	high efficiency microchannel heat exchangers, larger sized heat exchangers	9.1%	28.6%	Heat exchanger size constraints, Tradeoffs with pressure drop and fouling for microchannel heat exchangers
Efficient Compressors	two-stage rotary compressors, high efficiency scroll compressors with DC motors	6.5%	18.7%	Cost of moving from single to two stage compressor is high
Inverter/Variable Speed	AC, AC/DC or DC inverter driven compressors	20%	24.8%	Costs of DC motors with variable speed drives
Expansion Valve	Thermostatic and electronic expansion valves	5%	8.8%	Additional costs of electronic controller
Crankcase Heating	Reduced crankcase heating power and duration	9.8%	10.7%	Tradeoff in terms of starting/preheating time
Standby load	Reduced standby loads	2.2%	2.2%	Tradeoffs with all standby functions other than reactivation

<sup>10</sup> In that case, the A/C cannot operate in the reverse cycle to supply heating.

### 2.3.1.1 Compressors

#### Compressor energy efficiency gains

Improving the efficiency of the compressor remains central to achieving improved efficiency for a vapor compression based air conditioner. Typically the use of scroll and rotary compressors are likely to be used in the cooling capacity range required by residential air conditioners. A commercially available energy-efficient rotary vane compressor ranges from 2.8 to 3.2<sup>11</sup> W/W and can reach up to 3.2 W/W for scroll compressors.

In the rotary compressor it is the rotating action of the roller inside the cylinder which compresses the refrigerant. The eccentrically oriented roller rotates around a shaft such that this part of the roller is continually in contact with the inside of the cylinder wall. The blade which is spring-mounted always rubs against the roller. These two points of contact form two sealed regions of continually varying volume within the cylinder. At a certain point of the rotary cycle, the port intake is exposed and draws a certain quantity of the refrigerant into the cylinder, thus filling one of the sealed regions. The roller continues to rotate, forcing the refrigerant to undergo compression as the volume available for the refrigerant to occupy decreases. When the exhaust valve is exposed the high-pressure refrigerant forces the exhaust valve to open, thus releasing the refrigerant. The diagram in Figure 2-2 2-2 below provides a schematic representation of the compression cycle in a rotary fix-vane compressor (EuP, 2009).

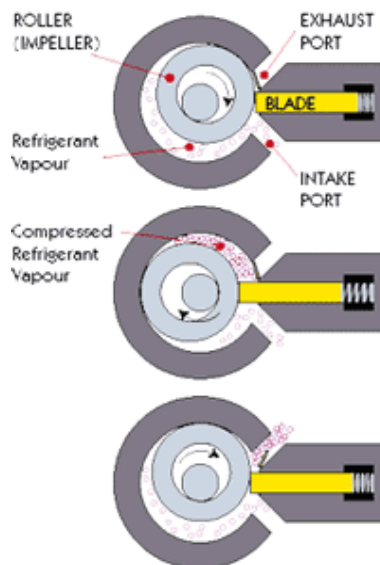

Figure 2-2: Compression cycle in rotary fix-vane compressors

Source: EuP, 2009

The capacity of the scroll compressor ranges from one to twenty horse power. It uses a stationary and orbiting scroll which compresses the refrigerant gas vapors between the evaporator and the condenser. The stationary upper scroll contains the refrigerant gas discharge port. The orbiting lower scroll is driven by an electric motor shaft assembly which imparts the eccentric/orbiting motion around the shaft center.

---

<sup>11</sup> using the ARI rating conditions for compressors

See Figure 2-3 for an illustration of the compression cycle in a scroll compressor.

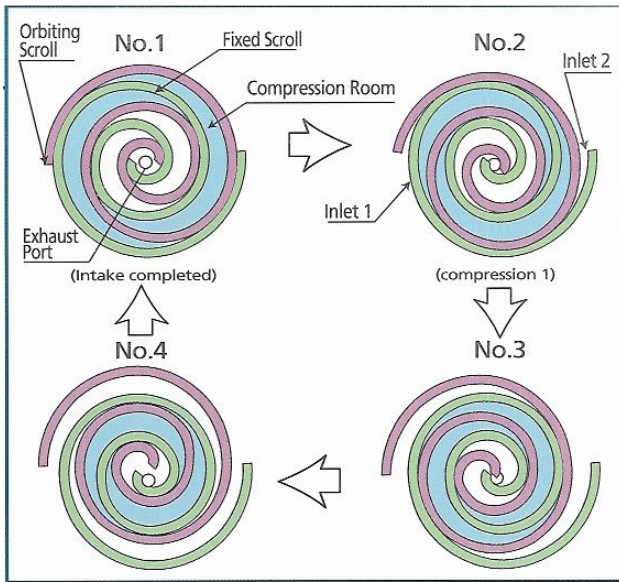

Figure 2-3: Compression cycle in a scroll compressor

Source: EuP, 2009

The cooling capacity of reciprocating compressors ranges from one to several hundred horsepower. They work best when they are used with refrigerants that call for relatively small displacement and condensing at high pressures. Between the top of the piston and the valve plate a small clearance gap exists to prevent the piston striking the valve plates. Vapor remains in this gap and not all of it escapes through the discharge valve at the end of a compression cycle. At the start of a cycle, the piston moves downwards and allows vapor to expand and reduce pressure. Compared to the pressure in the suction line the reduced pressure in the cylinder causes vapor to be drawn in. When the pressure equalizes, the suction valve closes. Then, the piston moves upwards, the vapor is compressed and the pressure increases. Then, because the pressure in the cylinder is now higher than that in the discharge line, the discharge valve is forced to open and the high pressured vapor is released. The cycle is repeated where vapor remains. The valves are accountable for head losses at suction and discharge ports, but also facilitate the adaptation to varying pressure conditions by the compressor. The figure below illustrates the compression cycle in the reciprocating compressor.

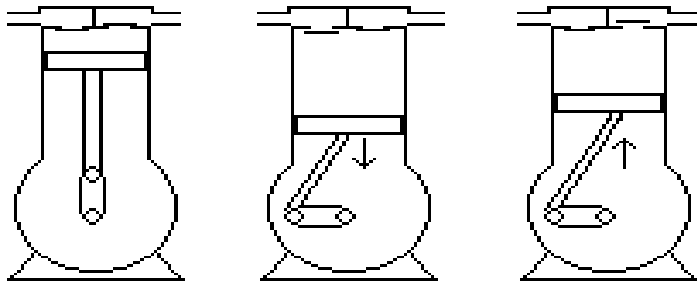

Figure 2-4: Compression cycle in the reciprocating compressor

Source: EuP, 2009

The relative efficiency advantage of scroll, rotary and displacement compressor technology depends on the desired cooling capacity. Rotary compressors are the most common types of compressor for low capacity units (below 6 kW) and multi-split air conditioners. For larger capacity units, scroll compressors are often used, alongside reciprocating (displacement) compressors. Since 1965 scroll compressor efficiency, when expressed as the fraction of the isentropic efficiency, rose from 0.48 to 0.73 in 2002. The rate of improvement, however, is slowing and only more modest additional improvements are expected in the future. The total “heat insulated” efficiency of scroll compressors, i.e. the ratio between the work supplied to the fluid and the electric power delivered by the motor of the compressor, reached 80% in 2004 (ECCJ, 2006). Thus when coupled with a high efficiency motor, overall compressor efficiencies of about 75% are currently attained. The energy efficiency of rotary compressors has also continued to improve especially through the reduction in friction losses and by minimizing leakage between the high and low pressure sides. Some Japanese manufacturers have adopted rotary compressors with two stages, i.e. using twin rotary compression that has increased compressor efficiency by ~10%. The use of very high efficiency DC motors with optimized scroll compressors is another high efficiency solution (JRAIA, 2006).

**Compressor motors**

Standard permanent split capacitor (PSC) motors operate typically at 60% efficiency. The energy efficiency of small capacity motors are shown in Figure 2-5. Improvements in DC motors can be achieved by shifting to a 6-pole motor where motor volumes can be reduced by up to 30% and motor losses reduced by up to 20% when compared to typical 4 pole DC motors.

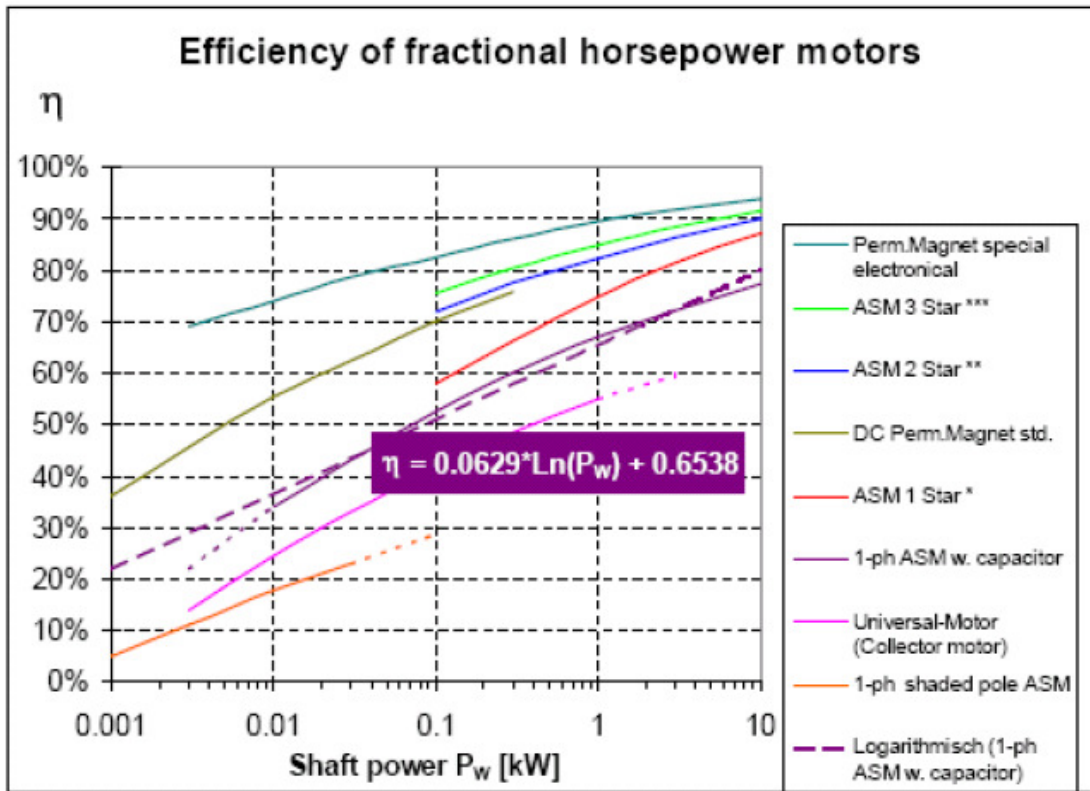

Figure 2-5: Efficiency of fractional horsepower motors

Source: EuP, 2009

DC motors with variable speeds can be developed by improving the form of the wave signal of the current delivered to the motor by shifting from square signals to sine wave current forms; illustrated in Figure 2-6 (ACCESS, 2008). This has been driven by the development of control technology capable of using the motor current to estimate the rotor position as well as a marked improvement in the arithmetic performance of micro-computers.

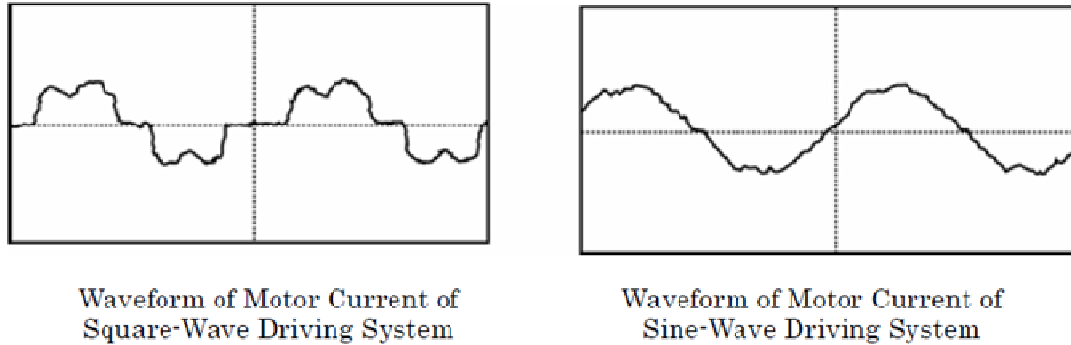

Figure 2-6: Evolution of Motor Current Waveform

Source: ACCESS, 2008

New methods are being continuously developed to achieve a further increase in DC motor efficiency and surpass the standard 80% efficiency. One such technique examines the use of a neodymium magnet which has a higher magnetic flux density and replaces the ferrite element of the conventional motor. Another method focuses on reducing the copper losses by designing an improved geometry for the coil winding. Another technology has even started to use thin silicon steel plates or laminated steel sheets to limit the iron losses. In Japan such efforts have enabled 1kW motors to reach efficiencies of up to 95% (ECCJ, 2006).

### Stepped capacity and variable speed compressors

The use of technologies that lead the cooling capacity of the unit to react to changes in the required cooling load can result in significant differences in the overall seasonal energy efficiency (SEER) and may also improve the full capacity operating efficiency. Seasonal efficiency is enhanced because the performance improves at reduced refrigerant flow rates compared to air conditioning units that cycle on and off. Inverters (also known as variable speed drives) are the preferred means of doing this. Inverter driven units also provide manufacturers with the freedom to increase or decrease the rated cooling capacity and EER of the air conditioning unit as a function of the EER versus cooling capacity performance of the appliance at varying cooling capacity levels, as illustrated in Figure 2-7.

Important progress has been made in optimizing the compressor efficiency when operated at variable frequency. The increased use of high efficiency DC motors has resulted in significant gains at rated and, more so, reduced speeds. This has resulted in an increase in the range of operation of inverter controlled compressors and efficiency has been maintained and in some cases improved compared with the EER at full-load performance. Now, DC inverter driven rotary compressors can operate between 8 and 120 Hz with a peak efficiency of 30 Hz, while scroll compressors can operate between 40 Hz and 180 Hz.

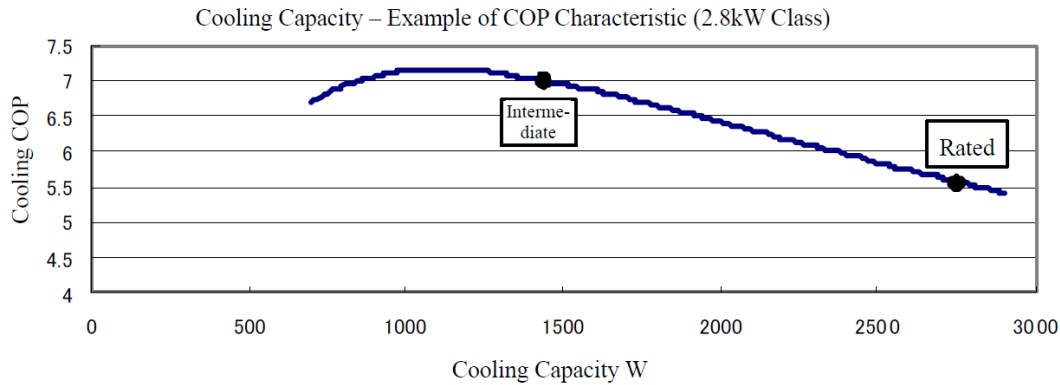

**Figure 2-7: COP (W/W) as a function of cooling capacity for an inverter driven AC**

Source: ECCJ, 2006

High speed operation in the heating mode enables capacity to be maintained until  $-15^{\circ}\text{C}$  (Daikin, 2007) by raising the frequency when the outdoor air temperature falls. This is a definitive advantage for a seasonal performance index rating, as in field operations. Although the efficiency levels may be low, they are still higher than with the addition of resistive heating.

### 2.3.1.2 Fans

Room air conditioners typically consist of a single motor driving two fans, the condenser and evaporator blower fans. A variety of fan types can be used in room air conditioners, as illustrated in Figure 2-8. Cross-flow fans or centrifugal fans are used to produce forced air flow for indoor units, whereas axial fans tend to be used in the outdoor units. Variable speed electrical motors are used to drive these fans in order to adjust the air flow rate as required by the end-users. The type of fans used for split and multi-split systems varies for these indoor units, however, most of the outdoor fan units tend to be of the axial variety. Window or wall units tend to use centrifugal fans for both sides. Whereas, in the case of single and double duct systems a single fan (centrifugal) is used for both the condenser and evaporator coils. Mobile split units use centrifugal fans indoor and axial fans for the outdoor (EuP, 2009). Any design improvements in the fan which seek to improve the air flow characteristics can have a marked reduction in power demand from the fan motor and thus increase the overall efficiency. It is important to note, however, that any design changes to improve air flow must be developed in the context of space limitations of in-room air conditioners and that any design changes in the heat exchanger may lead to alterations in the air flow.



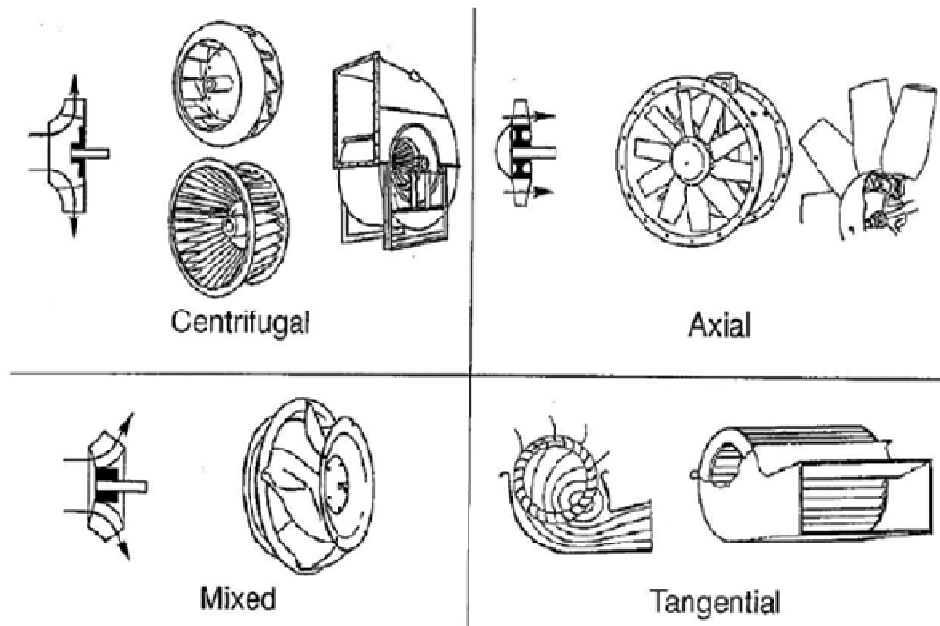

Figure 2-8: Types of Different Fans

Source: Corry, 1992

**Fan motors and drive:** The same advances discussed for compressor motors are applicable to fan motors, except that because the average input power needs are lower, the relative gain in motor efficiency is higher (due to the poorer average efficiency of low power motors compared to higher power motors). The efficiency of a standard 100W AC fan motor can be dramatically improved upon through the use of a DC motor with advanced features such as 6 or 8 poles instead of 4, or rare-earth magnet types. With the best available technologies reaching more than 80% motor efficiency, as is the case of the efficiency of compressor motors (ECCJ, 2006). This evolution in fan motor efficiency is illustrated in Figure 2-9 below.

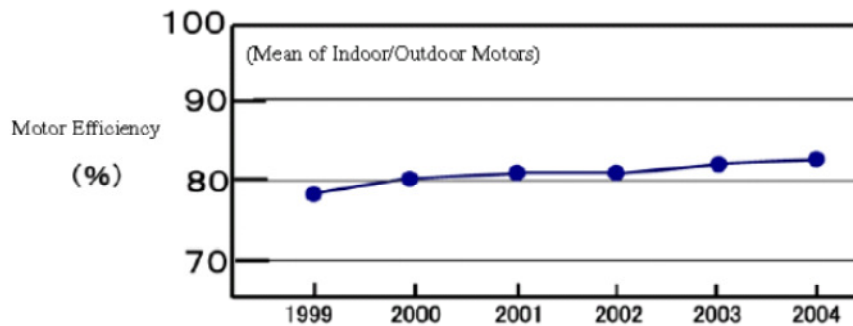

Figure 2-9: Evolution in Japanese air conditioner fan motor efficiency

Source: ECCJ, 2006

**Axial or propeller fans:** The efficiency of propeller fans has improved significantly. Older versions were made of processed metals, whereas plastics are now used in the more efficient models. The shape has also



progressively evolved in order to increase the volumetric efficiency and achieve a reduced noise level.

This evolutionary process moving from a 2D wing in the mid/late 1970s to a hybrid wing design in the late 1990s/early 2000s is summarized by Figure 2-10.

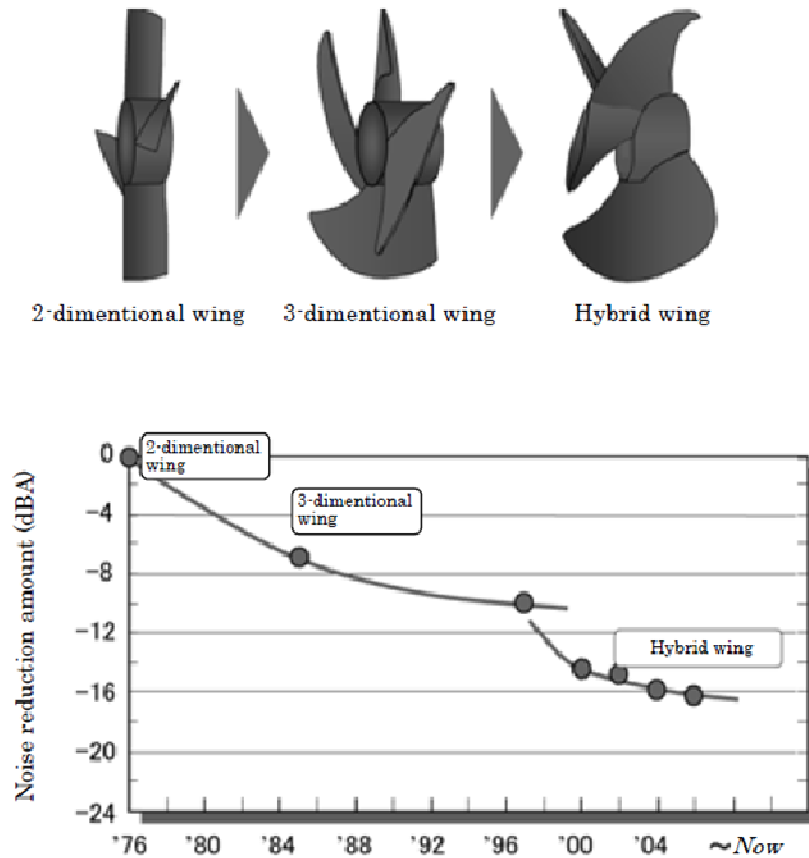

Figure 2-10: Evolution of Axial/Propeller Fan Design

Source: ACCESS, 2008

More recent developments include design adaptations in order to cope with operation in extreme cold weather conditions which induce a higher static pressure condition on the coil when frozen. This is illustrated in Figure 2-11 below.

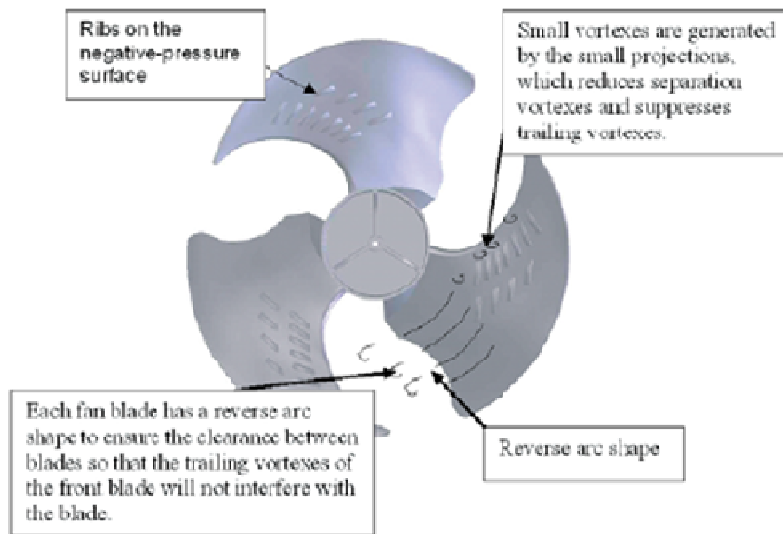

Figure 2-11: Axial Fan Design for A/C Condenser under High Static Pressure

Source: Daikin, 2007 and EuP, 2009

**Cross flow fans:** The mechanical efficiency of cross flow fans tends to be about half of that currently achieved by axial fans in standard split air conditioners. An attempt to increase air volume has been made through the introduction of plastic blades with a wing-shaped section and increasing the fan diameter, which improves efficiency while controlling noise. Improvements in the layout and molding of the fan and blades have been achieved by introducing spacing between blades as well as angling the fan shaft. This cross flow fan blade design is illustrated in Figure 2-12.

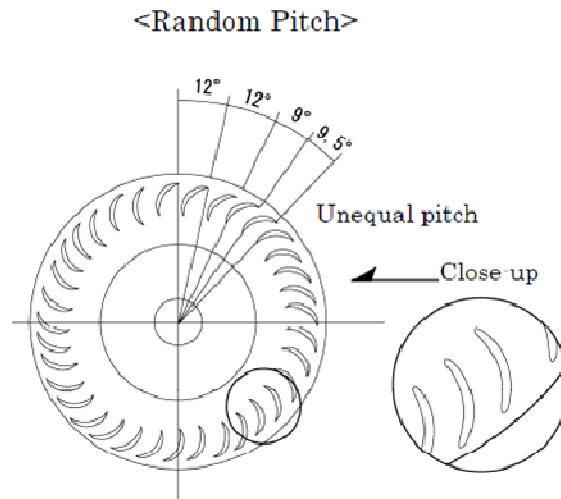

Figure 2-12: Latest Design of Cross Flow Fan Design

Source: ACCESS, 2008

**Centrifugal fans:** the use of forward blades has a lateral fix with a mechanical efficiency of 40%. The use of central fix rotors in centrifugal fans can improve the mechanical efficiency from 40% to 60% (EuP, 2009).

**Reduced pressure losses:** There is inevitably a trade-off in achieving a performance increase in the heat exchanger with a higher level of compactness and an increase in air-side pressure drops and related fan power consumption. As such all these considerations must be weighed-up when finalizing the overall system design.

**Turbo Fans:** The use of turbo fans is typical in the cassette indoor unit. The turbo fan has undergone significant improvements with the integration of three-dimensional blades, as illustrated in Figure 2-13 (ACCESS, 2008).



Figure 2-13: Turbo Fan with 3-D Blades

Source: ACCESS, 2008

### 2.3.1.3 Heat Exchangers

The thermodynamic cycle efficiency of air conditioners increases when the difference in the refrigerant evaporating and condensing temperature decreases. This difference is primarily constrained by the outdoor fluid temperature; however, to a lesser effect it is due to the temperature difference between the refrigerant and the outdoor fluid. This can be reduced by improving the performance of the heat exchanger, in which case the compressor will operate more efficiently than at rated conditions.

The simplest means of doing this is to increase the heat transfer area by increasing the frontal area of the coils and/or the number of rows of tubing in the coil. This, in turn, tends to increase the amount of copper used in the tubes and the amount of aluminum used in the fins, as well as usually raising the amount of refrigerant charge. An increase of the heat exchange area by 80% (by increasing the number of tubes while maintaining a constant horizontal tube spacing as well as other physical coil parameters), achieves a 35% increase in the efficiency of the unit (not accounting for the fans) when the air flow rate is set at constant and thus the air speed at the coil first tube row is reduced by a half. The improvement in compressor efficiency is approximately 80% with a constant air speed at the coil, although this requires the air flow rate to be doubled. Higher air flow increases noise so there can be a trade-off between the increased heat transfer efficiency and increased noise. Furthermore, increasing the heat exchanger surface area tends to increase the size and weight of the coils and their housings.

Figure 2-14 (below) shows the evolution in the size of the indoor and outdoor units of Japanese mini-splits in response to the rapid increase in efficiency required by the Top Runner program. In Japan in order to achieve an efficiency improvement from COP 2.8 W/W to COP 6.2 W/W ( $EER + COP / 2$ ), the mass of both heat exchangers increases by about 50%. It is estimated that heat exchanger improvements may have accounted for half of the overall efficiency gain. Recent data demonstrates that manufacturers have found methods to reduce the mass of the heat exchangers while maintaining the same efficiency levels, however, the dimensions remain the same and in some cases have increased (ECCJ, 2006).

Dimensions and Mass of Highest-COP and Lowest-COP Air Conditioners

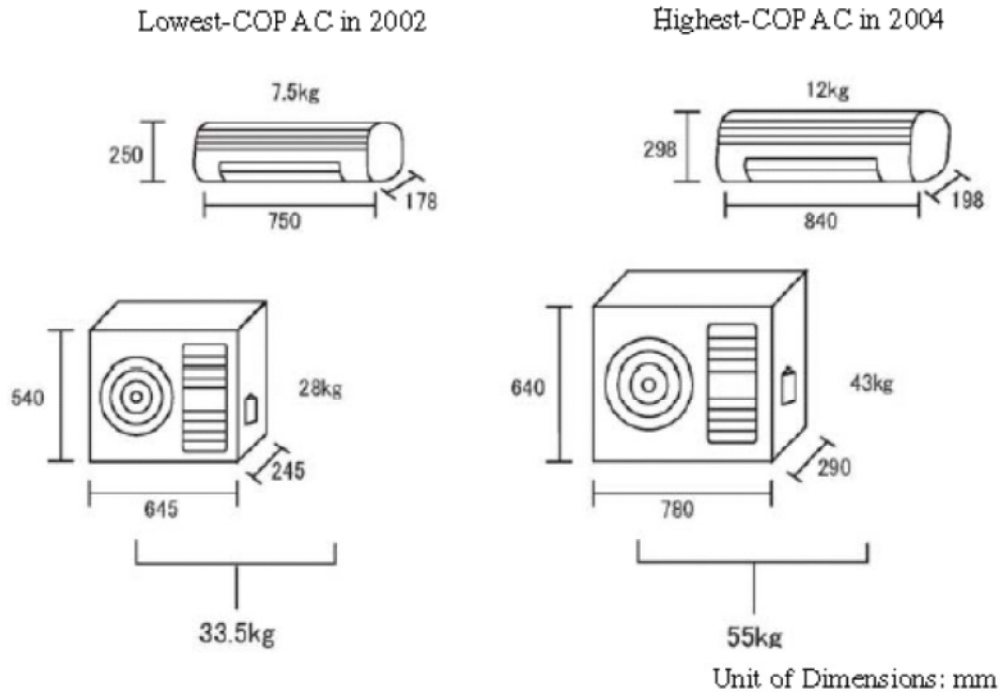

Figure 2-14: Evolution in mass and dimensions of 2.8 kW AC units in Japan

Source: ECCJ, 2006

The effective heat exchange area can also be enhanced by increasing the density of the cooling fins. When evaluating the use of reversible units, it is important to note that there is a trade-off between an increased performance in cooling mode and a decrease in performance under frosty conditions in the heating mode. Moreover, in the cooling mode, an excessively high cooling fin density can result in intensified coil fouling.

**Increased heat transfer efficiency**

Resistance to heat exchange between refrigerant fluid and air can be decreased by improving the refrigerant tube or fin design. The conduction efficiency of refrigerant tubing made out of high quality copper is already very high.

Heat transfer rates increase when cooling fin patterns evolve from smooth to louvered and variegated surfaces. It is thought there is a potential to improve AC efficiency by a further 10% through the use of optimized slit fins in place of plain fins. Several fin patterns have been introduced to maintain good heat transfer quality while achieving lower noise levels and lower production costs. It is thought more recent evolutions in fin design may introduce air-side heat transfer gains of greater than 2 compared to plate fins. The various patterns which have evolved through time (from left to right, i.e. A to E) are presented below in Figure 2-15.

Use	Indoor				Outdoor				
Type	Type A	Type B	Type C	Type E	Type A	Type B	Type C	Type D	Type E
Fin shape									

Figure 2-15: Fin Pattern Evolution

Source: Daikin, 2007 and EuP, 2009

Adoption of the latest inner-tube design patterns enables heat transfer resistance to be cut by a factor of four compared to smooth tubes. This evolution is also coupled to a decrease in the tube diameter and thickness. In order for the increase in heat exchange to not be overly detrimental to drops in the refrigerant pressure within the heat exchangers, the diameter of the copper tube is adapted to the refrigerant conditions, so that larger diameters are used for the gaseous state and lower diameters for the liquid or diphasic state (ECCJ, 2006). These measures also enable the refrigerant charge to be decreased. The most recent evolutions are thought to increase refrigerant-side heat transfer gain by a factor of more than three compared to that achieved using tubes with smooth plates. The evolution of the inner refrigerant copper tube design is illustrated in Figure 2-16 below.

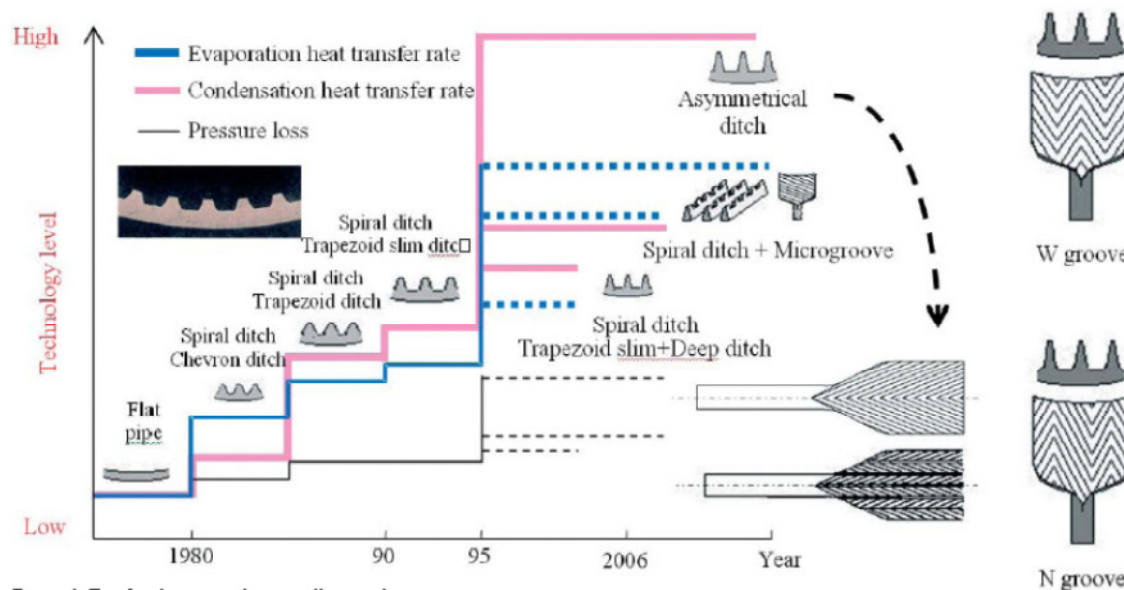

Figure 2-16: Evolution of copper tube designs for indoor coils in Japan

Source: Daikin, 2007 and ECCJ, 2006

**Micro-channel heat exchangers:** the micro-channel heat exchangers are made using flat tubes which have a rectangular cross section of 1-3mm. The fins are brazed to the tubes and run between them. As a result, the micro-channel coil system transfers a greater proportion of heat per unit of face area than the conventional heat exchangers of equivalent capacity.

It also achieves this with a lower airside pressure drop and thus lowers fan power consumption. It

therefore presents an opportunity to decrease the material required and thus enable the units to increase their equivalent heat exchange areas at a constant cabinet size. In principle the refrigerant charge could be decreased by 20 to 40% for packaged units for a coil of equal capacity. At the same time heat exchanger performance can be increased by 10% for an equal front coil area compared to the traditional round tube and fins air coils. This innovation has been anticipated for a long time and has been adopted in air conditioning systems used by the car industry for over five years. One of the problems for the application of micro-channel heat exchangers within reversible split air conditioning units is that it prevents condensate coil drainage and may have a negative effect on heat pump evaporators; however, such technology has been successfully applied in cooling-only chillers. Despite the aforementioned advantages, micro-channel heat exchangers do not seem to be a technical option for improving the efficiency of split or single duct air conditioners (at present). Several central air conditioner manufacturers in the US seeking to achieve high SEER units use micro-channel heat exchangers. It is thought they are primarily used for the indoor heat exchanger and not the condenser since they would increase EER in cooling mode but may decrease COP in frost conditions.

**Evaporative cooled condensers:** Spraying water on the outdoor air or refrigerant heat exchanger facilitates an improved thermodynamic performance of the heat exchanger in dry climates. The efficiency of this option is highly dependent on the outdoor air temperature and humidity content.

#### **Adding Subcooler to Condenser Coil**

Subcoolers are integrated between the capillary tube inlet and the condenser coil outlet. They are typically immersed in the condensate created by the evaporator and lie in close proximity to the condenser system. The addition of the subcooler acts to increase the scale of the condenser coil, however, it does have the added benefit that it provides additional cooling for the refrigerant leaving the condenser. The main challenge lies in accommodating the larger condenser coil system into the tight residential air conditioning unit. In a simulation model developed by the European Commission Directorate General for Energy (DGXVII, 1999) they evaluated the impact of the addition of the subcooler to the condenser coil and it emerged that a potential 1% increase in EER could be achieved by its integration.

In the DOE's energy model which was used to evaluate the addition of the subcooler it confirmed the European Commission's earlier work that the subcooler can make a small improvement in efficiency while still being cost effective and not requiring a change in the chassis size.

#### **Hydrophilic Film Fin Coating**

The formation of water condensate upon the heat exchanger fins causes a bridging effect between the fin spacing. This results in a decrease in the heat transfer performance as well as an increased drop in air pressure. The addition of the hydrophilic coating on the heat exchanger fins reduces the thickness of the condensate layer and enables an increased ability for the water to drain off the fins allowing a reduced air side pressure drop and an increased airflow across the heat exchanger. In the US it has been shown that the use of such a hydrophilic film coating on the heat exchanger fins can reduce the pressure drop between 20-50% when operating in high humidity room-side air environments (TSD, 2010b).

#### **2.3.1.4 Expansion Devices**

In order to create high and low pressure states in a refrigeration cycle an expansion valve is used. The role of the expansion valve is to control the flow of fluid into the evaporator. In standard efficiency air conditioning equipment, the expansion of the refrigerant between the condenser and evaporator is made through a pressure loss produced by restricting the diameter of the piping; either by an orifice of constant diameter or a capillary tube of a given length. Such low cost solutions enable the superheat to be controlled relatively efficiently at the rated design condition. Because, however, the superheat is uncontrolled away from the design point, it is necessary to design the product for relatively high superheat values (typically in the order of 5 to 10K (EuP, 2009)) to avoid harmful liquid suction at the compressor inlet. There are several means to improve the performance of the expansion device under various design operating conditions.

Thermostatic expansion valves (TXV) adjust the refrigerant mass flow rate in order to achieve an almost constant level of superheat whatever the operating conditions are. When TXVs are appropriately designed and integrated, the design superheat can be reduced to 4 to 7K (EuP, 2009). The superheat is controlled by the equilibrium of three system pressures: the condenser side pressure; the evaporating pressure; and the pressure related to the superheat temperature. This can lead to small variations around the set point depending on the evaporating pressure. Moreover, at very low load, there are stability problems that may lead to the shunting of the valve and significant energy losses. TXV also help to block refrigerant migration when the compressor is cycling and thus produce additional energy savings at part load. As a result the  $C_D$  coefficient<sup>12</sup> decreases from a typical 0.2 level to less than 0.14 (EuP, 2009). Further gains can be obtained with an electronic expansion valve. In this case design superheat can be as low as 2K which allows the  $C_D$  coefficient to decrease to 0.10 or lower.

The electronically controlled expansion valve enables a correct and adaptable level of throttling based on electronic signaling from a micro-computer which determines the air conditioner operating state. A pulse motor fed by an electronic signal is used to control the valve, which in turn controls the degree of throttling. This enables the efficient control of the refrigerant flow, depending on the operating state. The operating characteristics are similar to the TXV except for the increased precision achieved by the electronic valve which in turn enables lower superheat values and the ability to overcome the limits of the TXVs thermo-mechanical design. As is the case with the variable speed compressors, the key benefit of electronic expansion valves is the improvement of seasonal energy efficiency. An added benefit of the electronic expansion valve (as with TXV with hermetic closure) is the capability to stop refrigerant migration under on/off cycling or when the unit is off. A schematic representation of the electronically controlled expansion valve is illustrated in Figure 2-17 below.

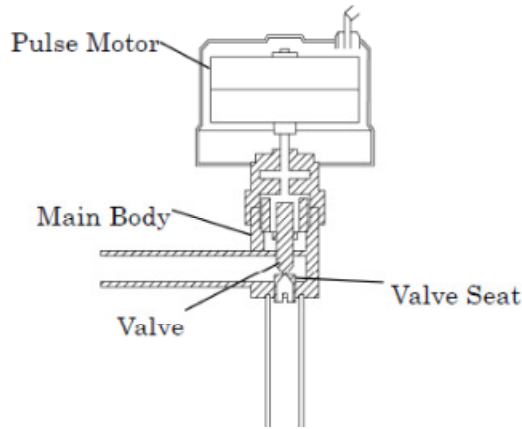

**Figure 2-17: Electronic Expansion Valve Schematic**

Source: ACCESS, 2008

---

<sup>12</sup>  $C_D$  is the “Cyclic Degradation Coefficient”, often used in measuring the performance of the system at part load. A low  $C_D$  implies better performance at part load.



### 2.3.1.5 Crankcase Heater

Crankcase heater consumption is the second largest consumption cause for reversible air conditioners in Europe with the assumption that the heater is cut at 10 °C outdoor. The oil heater maintains the oil temperature higher than in the other parts of the system to avoid high refrigerant concentration levels in the oil. (EuP, 2009) discusses how far the crankcase heater consumption may be reduced.

By keeping track of representative temperatures of the oil sump and of the outdoor unit, it is possible to cut energy consumption by 50 % (Daikin, 2006) by using this control in addition to an outdoor air 12 °C control. The drawback to this approach is that it necessitates more electric circuitry that increases standby and off mode power. In addition, though crankcase heating is only necessary before start-up, and only in cold climates, the time required varies by system, and climactic conditions. By installing a solenoid valve before the expansion valve or using an electronic expansion valve that can close and remain refrigerant tight, it is possible to pump down the evaporator before the compressor is cut.

Further, since the oil heater is generally located outside the compressor shell, the greater part of the energy supplied by the crankcase heater is wasted. Compressor and equipment manufacturers use electrified stator coils that allow reduced crankcase heater power. Best available technologies, following (EuP, 2009) consume about 10 W for 2.8 kW and 25 W for 8 kW split units respectively equipped with rotary vane single and double stage compressors, i.e. about 3.5 W per kW cooling.

Also, manufacturers are employing various control strategies to reduce the power consumption of the crankcase heater. Either the control temperature is lowered, or (and) the control is improved by heating as a function of the difference between oil sump temperature and indoor refrigerant temperature, or (and) the crankcase heater is used only to preheat before operation, which can be done with no decrease in end user comfort conditions.

It appears that the best strategy for reducing crankcase heater power consumption would be to use the crankcase heater only before the heating function, removing it from off mode functions and to a great degree from standby power consumption. (EuP, 2009) estimates that the best available technologies enable a reduction in the preheating power consumption by a factor of 6 from current levels.

### 2.3.1.6 Standby Power

The best commercially available reversible split-packaged Room ACs currently consume 0.7 W in standby mode. According to (EuP 2009), standby power consumption could be reduced to 0.3 W for the indoor unit by switching off functions other than the reactivation function. For the outdoor unit standby power depends climate conditions and on the size of the crankcase heater. For larger capacity units which could have several indoor units, the same technology that is used for small split systems could enable the outdoor unit standby power consumption to reach 0.4 W depending on the crankcase heater size. Further, a hard off switch could help to reach 0 W off mode. Even in case a timer program is used, there are options available to drastically reduce these values (EuP 2009) to 0.3 W and lower.

### 2.3.1.7 Improvement of Thermodynamics Cycle

**Improved operation at low outdoor air temperature:** Improvements in the cycle are expected to improve the performance of air-to-air heat pumps operating in heating mode at low ambient temperatures. For air-based heat pumps, an injection of vapor at an intermediate suction port in the compressor can produce an increase in heating capacity at lower ambient temperatures and a slight associated increase in COP. Figure 2-18 shows the heating capacity of a Mitsubishi air-based split heat pump that is achieved via the combination of an inverter controlled scroll compressor (enabling higher frequency cycling at lower ambient temperature) using additional vapor-injection as described above. Full design capacity can be maintained until  $-15^{\circ}\text{C}$  with a COP increase likely to lie between 2% at  $2^{\circ}\text{C}$  and 15% below  $-7^{\circ}\text{C}$  as compared to operations at high frequency and low indoor air temperature (EuP, 2009).



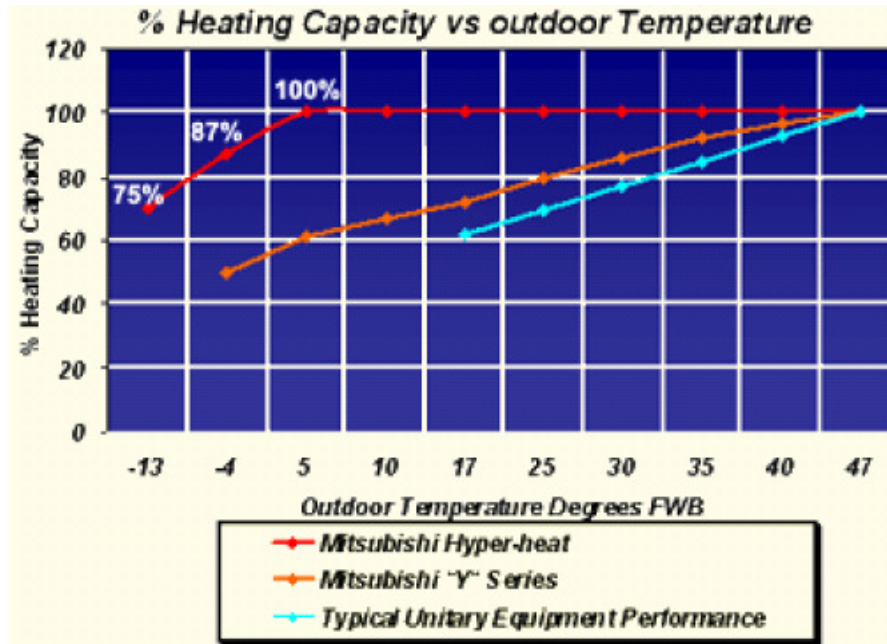
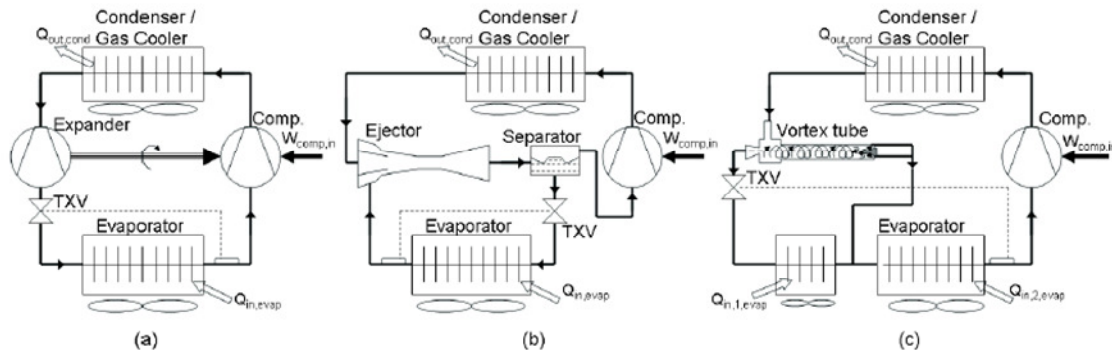
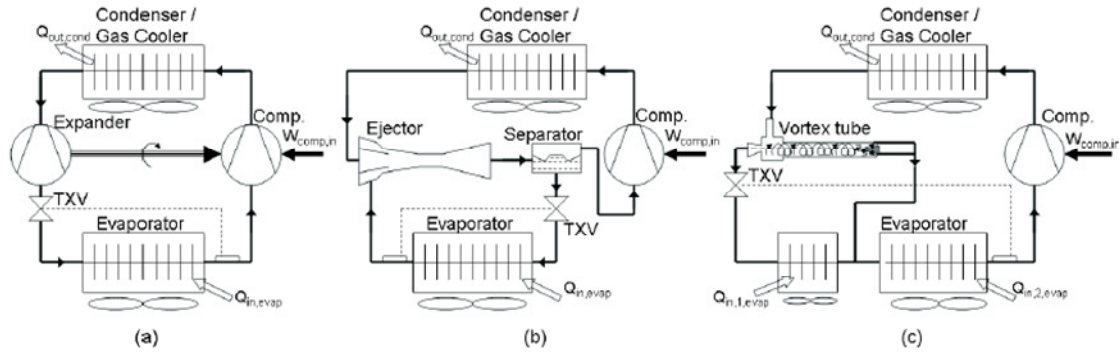

Figure 2-18: Variation of heating capacity as a function of outdoor air temperature of an air-based heat pump with vapor injection

Source: EuP, 2009

The use of expanders is thought to yield up to a 30% cycle improvement (EuP, 2009). Ejectors that make use of the flash kinetic energy to lower the compressor lift also appear to be a promising technology. These cycles are, however, still at the prototype level and require further development. The heat pump cycle improvements for low ambient are illustrated in Figure 2-19.

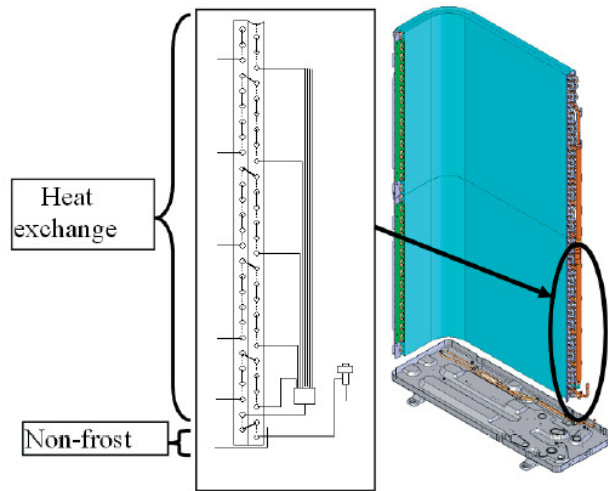



**Figure 2-19: Improvement for low ambient heat pump cycle- (a) Expander cycle, (b) Refrigerant ejector cycle, (c) vortex tube cycle**

Source: Cremaschi, 2007 and EuP, 2009

The diagram in Figure 2-20 (below) illustrates a modification on the outdoor air coil of a VRV system in order to improve its efficiency at low outdoor air temperatures, namely frosty conditions. This air-conditioner design employs a heat exchanger with a 15% larger frontal area compared to a conventional heat exchanger. This acts to enhance the heat exchange performance at lower temperatures. The tubing in the heat exchanger is adapted such that the tubes in the lower half provide a protection against the frost at lower temperatures. It is worth noting that this heat exchanger design has defined larger refrigerant paths in comparison to a typical heat exchange system in its class. The reason for this is to limit the pressure loss during heating as well as ensuring the prevention of frost formation at the bottom where the temperature is regulated to avoid formation of frost during the heating operation.



**Figure 2-20: Outdoor Piping Modifications to Increase Frost Condition Performance**

Source: EuP, 2009 and Daikin, 2007

Furthermore, as the water which is removed by the defrosting operation typically freezes at the bottom of the unit, it is likely this will ease the frosting of the coil. A solution to this is proposed by the manufacturer Daikin who has developed a freeze prevention pipe solution as illustrated in the diagram in Figure 2-21 below.

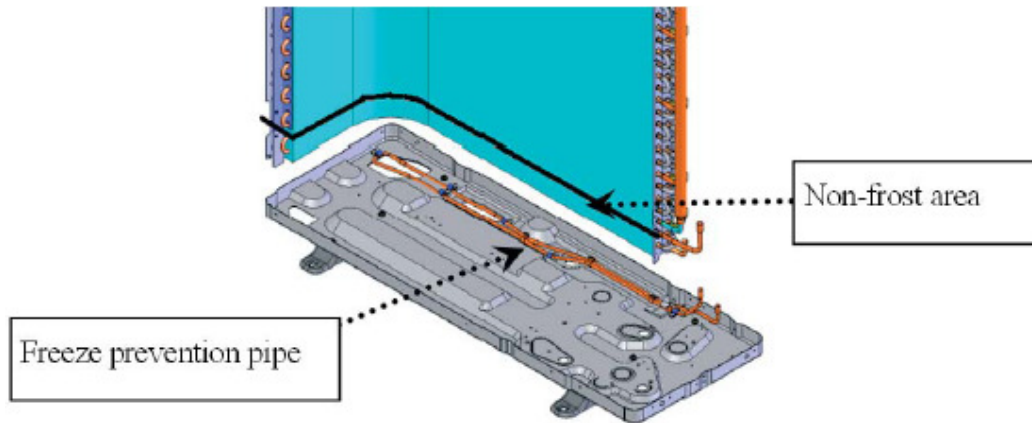

Figure 2-21: Freeze Prevention Pipe for Outdoor Unit Bottom Pipe

Source: EuP, 2009 and Daikin, 2007

**Other thermodynamic cycle improvements:** In order to improve the thermodynamic cycle performance at lower temperatures there is also the option to use internal heat recovery using a sub-cooled refrigerant and a vapor suction heat exchanger. It has been suggested, however, that it would be necessary to short-circuit the heat exchanger during periods of high outdoor air temperature as well as during cooling mode to prevent the loss of any efficiency gains which could lead to a fall in the overall energy performance (EuP, 2009). The adapted cycle including the liquid vapor heat exchanger schematic is presented in Figure 2-22.

As for the expansion turbine, it makes it an unlikely option for all fluids apart from CO<sub>2</sub> where either one of the two options could be used to achieve improvements in the basic cycle efficiency.

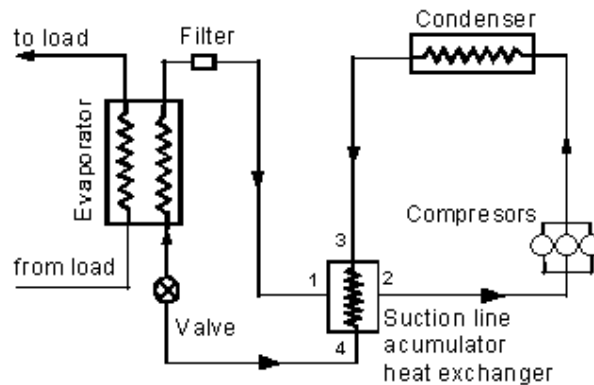

Figure 2-22: The modified cycle including liquid vapor heat exchanger schematic

Source: EuP, 2009

### 2.3.1.8 Refrigerant Fluid

There are a limited number of refrigerant fluids which can be used for room air conditioners. This is mainly confined by the large number of criteria which the refrigerant fluid must meet. Such criteria include: energy performance, safety, ozone depletion potential (ODP), global warming potential (GWP); technical constraints in terms of the fluid not interacting with the components of the system and economic constraints. Until the phase out of chlorofluorocarbons (CFCs) and hydrochlorofluorocarbons (HCFC) R22 was the universal refrigerant fluid of choice. After much research, replacement options have

and are being developed.

**Choice of Refrigerant:** The most efficient air conditioners in Europe, Japan and the USA now use R410A as it offers a significantly greater compactness and thus potential to increase the heat exchange area and therefore the efficiency. R410A is now the refrigerant of choice for advanced air to air appliances in all major air conditioning markets. Figure 2-23 illustrates the importance of refrigerant charge (mass) and energy efficiency for air conditioner devices using R410A.

The relative increase of the heat exchanger size for high efficiency models normalized by the rated capacity of the unit is the direct consequence of the increase of the refrigerant mass per kW cooling. This graph (Figure 2-23) illustrates that, in general, a doubling of energy efficiency is achieved by doubling the refrigerant charge.

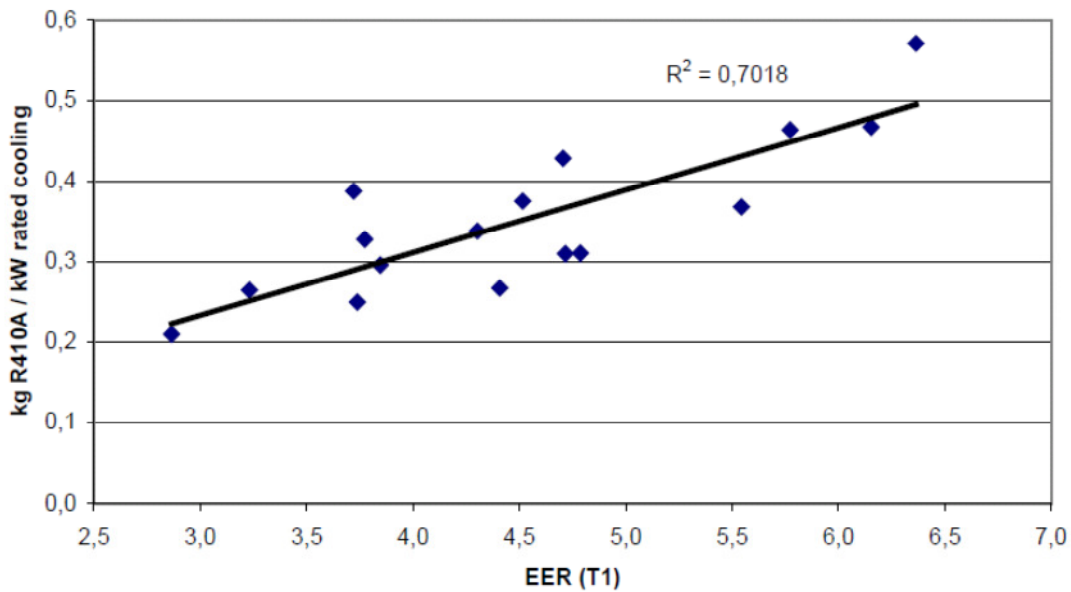

Figure 2-23: Relationship between efficiency and refrigerant charge per kW of cooling capacity

Source: JRAIA, 2006

The spread in values around the best-fit linear regression is a result of the use (or not) of smaller tube diameters compared with standard coil technology, or the transition to micro-channel technology which can help to limit the refrigerant charge per unit of cooling capacity. Micro-channel heat exchangers have the potential to reduce the refrigerant charge as much as 20 to 40% for a comparable efficiency to air conditioner devices that do not use this technology (EuP, 2009).

## 2.3.2 Other Options

### 2.3.2.1 Smart Grid Coupling

The smart grid is a response from governments, grid operators and users to update the ageing electricity power infrastructure so it can better accommodate increased electricity demand; manage the limited supply of electricity; help regulate emissions; and allow for technological evolution. In essence the smart grid uses advanced digital information based technologies to increase the grid efficiency, flexibility, reliability and reduce the need for an increase in power grid capacity. The smart grid makes use of products and services which can provide intelligent monitoring, control, two-way communication and adaptation.

The idea of having two way communication between consumers and suppliers in order to control

appliances is not new and has existed through analog systems for many years, however, the rapid development of the internet has enabled the use of a more well developed and equipped smart grid system. The increase in data, knowledge and information transmission capacity adds a new dimension to the two-way measurement, control and communication between all grid users at a more granular level. Devices such as smart meters are capable of communicating information on the state of the grid to users, operators and automated devices allowing for smaller energy consumers to respond to the grid conditions.

Manufacturers are continually developing devices which provide active feedback on electricity use and prices for energy consuming devices within the home. Highly developed smart grid enabled homes can incorporate smart grid sensors and feedback devices that respond to price change alerts from utility companies. For example, if a utility company issues a demand response message in the form of a price signal change, the smart meter relays this message to the residence. In this case there are several options available which depend on the set-up established by the home user:

- Continue to use electricity at the same rate
- Alter consumption to reflect the price change e.g. if the price rises then the user could evaluate the situation and decide to reduce or turn off the air conditioner device
- The automated system receives the demand response message through a gateway and implements a pre-configured energy-saving strategy which could include increasing the thermostat cooling set point in conjunction with lowering the sun facing shades. This automated system can be accessed by computer or mobile device and manually override the system's actions if necessary.

Such devices provide utility companies and consumers the ability to have contract agreements in place which enable the utility companies to automatically reduce the consumption of energy using devices such as air conditioners in response to the grid nearing maximum capacity.

The development of smart grid applications, like diagnostic tools, help optimize the operation of energy using devices and fix errors.

Mitsubishi was one of the first manufacturers to develop the smart air conditioner which displays the CO<sub>2</sub> emissions and electricity costs on an indoor panel as well as having occupancy sensor functionality (JFS, 2009).

The deployment of the smart grid would result in energy saving improvements from generation source to end-use of the electrical grid. This can be attributed to the reduced transmission and distribution line losses; improved and more efficient voltage control; and lower building energy consumption. It is important to note however, that significant investment remains before the smart grid infrastructure is able to perform as an effective demand response program that achieves substantial energy savings.

As part of a 2009/2010 pilot scheme<sup>13</sup> Honeywell Building Solutions distributed load management technologies such as smart thermostats and switches to homes in Topeka, Kansas and Milwaukee, Wisconsin. The technology allowed the participating utilities (Westar Energy, Topeka and We Energies, Milwaukee) to control the cycles of air conditioners in these homes, turning them on and off at intervals during the day. The aim of the pilot was to lower the energy bills of the participating homes and assist the participating utilities by decreasing energy consumption when demand was at its peak.

---

<sup>13</sup> <http://www51.honeywell.com/honeywell/news-events/press-releases-details/9.9.10DemandResponseProgramsForTwoMidwestUtilities.html>

The program hopes to reduce energy bills by up to 20% and the utility's energy load by 30 megawatts over three years in Topeka and 38 megawatts in Milwaukee.

In 2007 a demand response pilot project<sup>14</sup> was run by CCET (Center for the Commercialization of Electric Technologies) in Dallas and Houston residencies. It joined retail electric providers, transmission and distribution service providers and demand response-enabling technology providers. The 346 participating homes were provided with programmable, communicating thermostats which controlled air conditioners, pool pumps and water heaters. The program recorded demand reductions of 0.6 kW for houses in Dallas in the late Summer/early Autumn of 2008 although the study predicted that up to 1 kW could have been achieved had Hurricane Ike and some technology failures not occurred.

Con Edison New York offer their customers a free Carrier programmable thermostat as part of a demand response/central air-conditioning incentive program<sup>15</sup>. The program is available to home owners, religious institutions and businesses. The program pays the participant between \$0.50 and \$1.50 for each kWh reduced, and bonus payments for energy reductions during emergency events. Penalties may apply if reductions are not achieved.

### 2.3.2.2 Occupancy Sensors

The use of occupancy sensors can have a marked reduction in energy use by simply switching off the electrical loads of energy using devices when occupied areas are vacated or inactive for prolonged periods of time. While such sensors can be used to control a variety of load types in residential premises they have most aptly been used in commercial lighting.

Manufacturers and research institutions are actively researching the area of smart sensors in two areas, first in order to develop integrated sensors for energy devices and secondly to develop a series of intelligent sensor networks around the home to predict occupancy patterns for equipment optimization and to generate energy savings.

Efforts in the United Kingdom include the development of a newly emerging generation of smart environments referred to as predictive ambient intelligence environments which seek to learn from not only environmental changes but also occupant behavioral patterns. It is thought that this predictive feature can improve the performance of energy saving approaches in a smart environment as well as enhance occupants' comfort, safety and security. There are two main challenges facing these advanced occupancy sensor networks, these are data collection and prediction. The challenges in data collection are due to the energy and bandwidth constraints in sensor networks and the second is the complexity of learning in a distributed sensor network (Akhlaghinia et al., 2008).

Other manufacturers such as Mitsubishi Electricity Corp of Japan have developed room air conditioners equipped with integrated infra-red sensors. These sensors scan the visual field and detect the location of its occupants within the room as well as the temperatures of the floor and walls forming a database of thermographic data. The intelligent sensor processors are designed to optimize these inputs in order to yield energy savings while maintaining occupant comfort. When the room is occupied, the regulation of airflow for efficient operation is thought to yield up to a 40% reduction in electricity consumption and when the room is not occupied the system switches to an "energy-saving mode" which further reduces the energy use by 10% (JFS, 2007).

---

<sup>14</sup> [http://www.electrictechologycenter.com/dr\\_project\\_summary.html](http://www.electrictechologycenter.com/dr_project_summary.html)

<sup>15</sup> <http://www.conedprograms.com/>



Such technologies are undergoing continual research and development and are increasing in “intelligence” resulting in an optimized living environment as well as increased energy savings.

### 2.3.2.3 Climate Specific Efficiency Improvement Options

Some room AC efficiency improvement options are climate-specific in that they either are only feasible in certain climates or reduce AC energy consumption variably depending on the climate. Such options are presented in more detail in Appendix A, and summarized below:

#### *Evaporative Cooling*

Evaporative air conditioning (EAC) technologies are becoming increasingly popular in residential as well as commercial applications in countries with hot, dry climates.

EAC systems use water as the coolant as opposed to chemical refrigerants. EAC can provide superior ventilation and cooling over the traditional vapor compression air conditioning (VAC). However, unlike VAC systems which are capable of operating under a wide variety of climatic settings, EAC varies in effectiveness and efficiency with the relative humidity of the outside air. EACs have the added benefits that they reduce the requirement for traditional high ODP/GWP refrigerants, avert CO<sub>2</sub> emissions and reduce the peak electricity demand.

The Optimal operation for EACs is in hot, dry climates although they are applicable in more humid climates. EACs are widely used in the South Western US, Middle East, Australia, the Indian subcontinent, Eastern Africa and northern Mexico<sup>16</sup>.

Evaporative coolers can use up to 75% less electricity than conventional air conditioning which can equate to \$150 a year savings on electricity bills, this invariably depends on the climate of the building, for hotter desert like climates savings could be even higher (source:<sup>17</sup>) These systems do not use CFCs or any other ozone harming compounds and cost less to operate than conventional air conditioners including the initial cost of the unit and the installation costs. Another benefit of evaporative coolers is that they do not re-circulate ‘old’ air like other systems, rather they facilitate a complete air change every 1-3 minutes (source:<sup>18</sup>).

Drawbacks to the system include the high consumption of water, between 3.5 and 10.5 gallons per hour of operation; regular maintenance, units are often noisy; units can drip water and leak; and the units are less effective in high humidity climates and should only really be used in hot dry climates<sup>19</sup>.

#### *Free Cooling for Window/Louvered Air Conditioners*

Window (Europe) or through-the-wall (USA) package air conditioners are typically able to use cold outdoor air (during cooler periods such as nighttime) to free cool when the conditions are appropriate. Such systems use what is known as an economizer cycle, which has existed for several years.

---

<sup>16</sup> <http://www.coolmax.com.au/evaporative-cooling/evaporative-cooling-areas.htm> accessed 05/04/2011

<sup>17</sup> [http://www.consumerenergycenter.org/home/heating\\_cooling/evaporative.html](http://www.consumerenergycenter.org/home/heating_cooling/evaporative.html) accessed 04/04/2011

<sup>18</sup> <http://www.toolbase.org/Technology-Inventory/HVAC/evaporative-coolers> accessed 05/04/2011

<sup>19</sup> <http://www.azcentral.com/business/articles/2010/10/10/20101010biz-evaporative-coolers-disappearing-from-Phoenix-area-homes-1001.html> accessed 05/04/2011

Free cooling demonstrates the potential role of ventilation in securing indoor comfort without the need for mechanical cooling systems, although it is important to note that free cooling need not be viewed as an alternative to mechanical cooling. Indeed, it can be used in a complementary and supportive role for conventional air conditioning units with many studies demonstrating that significant energy savings of between 44% and 63% can be achieved with the use of free cooling in different climatic conditions.

There are, however, certain drawbacks and barriers which need to be weighed up; these include the cost of installation, introduction of outside noise and the need to include air treatment, which may be necessary to prevent air pollution being drawn in from the outside. It is also important to note that the energy saving benefit of a “free-cooling” option is not recorded under standard energy performance test conditions and hence is not reflected in energy efficiency ratings.

### *Storage of Cooling at Night*

Thermal storage technology is essentially the principle attached to materials which have the capacity to retain heat for a sustained period of time, often in the range of hours to a few days. A critical parameter is the material mass as it is reflective of the materials ability to retain heat – residential construction materials such as masonry exhibit this heat retention property.

Some storage materials are selected and situated so they can store cooling by drawing out the heat from the surrounding residential atmosphere, effectively cooling the spaces they occupy. The basic principle of night storage of cooling is to take advantage of the lower ambient temperatures at nighttime in order to accumulate low grade cooling energy and the cool radiant effect of chilled ceilings. Then the stored energy, referred to as cooling or coolth is gradually released during the daytime through radiation and convection. A recent study discussed in Appendix A found that cooling storage using such methods reduced AC energy consumption by over 21 %.(Wang et al., 2005)

### *Radiative cooling – Cool Roofs*

Roofing material with low reflectivity values tend to adsorb heat from sunlight rather than reflect it back into space. Roofing material with high emissivity will radiate any stored heat quickly. “Cool roofs” exploit these two phenomena by using combinations of high-reflectivity and high emissivity materials to minimize the amount of sunlight that is converted to heat in the roof material and maximize the amount of heat that is radiated away from the roof.

Studies have shown that reflective roofs are most effective where there is a high roof to volume ratio and that savings are greatest for buildings located in climates with longer cooling seasons and short heating seasons. Furthermore, many of these studies have shown that by raising roof reflectivity from 10-20% to about 60% cooling-energy use in buildings can be reduced in excess of 20% (Memon et al., 2008).

The benefits in equatorial, arid and warm temperate climates have led to incentive programs, product labeling and standards to promote cool roofs.

### *Shading with vegetation*

Plants, trees, and vegetation increase shading over the surface they occupy, blocking sunlight/heat from that surface. The heat that reaches either the greenery or the ground beneath it can often be dissipated through evapotranspiration – heat in the surrounding air/surfaces is used to evaporate the water. Often such greenery and its cooling effects are exploited in buildings such as “green roofs” on roof tops or strategically designed/naturally occurring “trees and vegetation” around buildings and urban spaces. Thanks to the natural processes of shading and evapotranspiration surfaces such as greens roofs stay cooler than conventional rooftops under summertime conditions.

In a study of green roofs the roof temperature of a standard flat roof was measured at 90°F and compared to a 60°F temperature which was recorded below the vegetation on an adjacent area of green roof. In previous studies it was observed that a 3-7°F drop in temperature could reduce air conditioning



loads by 10%, so taking this into consideration, if a green roof was installed on a one story building it could reduce air conditioning costs by up to 30% (Borgese, 2008).

It is, however, generally accepted that the use of urban trees and vegetation could face heat penalties in cold climates but reduce energy in hot climates.

## Chapter 3 Room AC Market and Energy Consumption Trends

In this chapter we discuss market, energy consumption and technology trends for Room ACs, including the dominant type of ACs, sales trends and the efficiency levels of ACs in each economy.

### 3.1 Split Packaged ACs Are the Dominant Type of Residential Air Conditioner

The global Room AC market is dominated by split-packaged (known in the US as mini-split) air conditioners. Based on a variety of data sources, Table 3-1 below presents the percentage of air conditioners in each market that are split-packaged units. In all markets except the US, split packaged ACs compose at least 62%(in India) to approximately 100% of the market.

**Table 3-1 Percentage share of split packaged ACs of Room AC market<sup>20</sup>**

Country	% split packaged	Data Type	Sample Size
Australia	76.0%	Government Data	
Brazil	~100%	Catalog	45
China	99.0%	Government Data	
EU	84.8%	Sales Average	
India	62.6%	Sales Average	
Japan	~100%	Catalog	307
Korea	99.0%	Government Data	
Mexico	79.0%	Catalog	82
Russia	~100%	Catalog	99
South Africa	91.0%	Catalog	51
UAE	79.0%	Catalog	67
USA	2.0%	AHRI(Industry Data)	

---

<sup>20</sup> Data shown in table 3-1 are based on a) samples obtained from catalog searches in the following economies: Brazil, Canada, Mexico, Russia, South Africa and the UAE, b) from the CLASP Mapping Report for China, EU, India, Japan and the USA, and c) from the IEA 4E Mapping Reports for Australia and Korea. (Baillargeon, 2011, IEA 4EM&B, 2010)

### 3.2 Average Capacity

Table 3-2 shows the average cooling/heating capacities of split packaged ACs sold in various economies. Average capacities range from 3.33 kW in China to 6.64 kW in the UAE, and reflect a number of factors including average room sizes, incomes and climates in the various economies.

**Table 3-2 Average Cooling (or Heating) Capacities in Various Economies<sup>21</sup>**

Country	Average Cooling ( or Heating) Capacity (kW)	Data Type	Sample Size
Australia	4.80	Government Data	
Brazil	4.07	Catalog	45
Canada	5.29	Catalog	139,210
China	3.33	Government Data	
EU	5.70	Sales Average	
India	5.50	Sales Average	
Japan	3.67	Catalog	307
Korea	5.90	Government Data	
Mexico	5.60	Catalog	82
Russia	4.93	Catalog	99
South Africa	5.42	Catalog	51
UAE	6.64	Catalog	67

---

<sup>21</sup> Data shown in table 3-2 are based on a) samples obtained from catalog searches in the following economies: Brazil, Canada, Mexico, Russia, South Africa and the UAE, b) from the CLASP Mapping Report for China, EU, India, and Japan and c) from the IEA 4E Mapping Reports (Baillargeon, 2011, IEA 4EM&B, 2010) for Australia and Korea.

### 3.3 Significant Potential for Efficiency Improvement Exists

The average energy efficiency of unducted mini-split ACs (a subset of split packaged ACs) which form the majority of global residential air conditioners in every country except the United States, varies from an average EER of 4.1 in Japan to an average of 2.69 in the UAE as shown in table 3-3 below. The Japanese market has the most efficient air conditioners that are commercially available, with a maximum EER of 6.67 W/W, and an average of 4.1.

Even though the data presented in Table 3-3 are illustrative and cannot be compared directly *across countries* due to lack of availability of overlapping data sets and minor differences in test procedures, these data can be compared *within* each country studied. Table 3-3 clearly and unequivocally show that there is a significant gap in efficiency terms between the best available split package AC in each economy and the average AC in that same economy. If the best available technology available globally is considered, it is even more evident that there is significant room for improvement in Room AC efficiency in all the economies, even if only ACs currently available on the market are considered.

**Table 3-3 Average EERs of unducted split-packaged ACs in various economies in 2010-2011(illustrative)<sup>22</sup>**

Country	EER (W/W)		
	Min	Max	Average
Australia	2.67	4.88	3.16
Brazil	2.92	4.04	3.19
Canada	2.14	4.33	3.6
China	2.9	6.14	3.23
EU	2.21	5.55	3.22
India	2.35	3.6	2.8
Japan	2.37	6.67	4.1
Korea	3.05	5.73	3.78
Mexico	2.42	4.1	2.92
Russia	2.5	3.6	2.79
South Africa	2.28	5	2.91
UAE	2.14	3.22	2.69
USA	-	4.6	3.04

Source: Catalog searches, IEA 4E M&B 2010, Baillargeon, 2011

<sup>22</sup> This data should be treated as illustrative as no overlapping datasets were available to cross-check these data points. Data shown in table 3-3 are based on a) samples obtained from catalog searches in Brazil, Canada, Mexico, Russia, South Africa and the UAE, b) from the IEA 4E Mapping and Benchmarking Analysis for Australia c) from the CLASP Mapping Report for China, EU, India, Japan and the USA, and d) from the IEA 4E Mapping and Benchmarking Analysis for Korea. (IEA 4E M&B 2010, Baillargeon, 2011)

### 3.4 Deployment of Variable Speed Compressors is Increasing

Sales of inverter driven ACs (which are more efficient at part load as discussed in chapter 2 earlier), are growing and have reached 100% of the market in Japan and a significant portion in the EU and Australia, driven by the recognition of part load energy savings in economies using seasonal energy efficiency metrics such as ESEER (Europe) or APF (Japan), as shown in Table 3-4. This trend is promising in terms of energy savings and will help reduce future energy consumption as countries adopt efficiency metrics that reward part-load savings, particularly where large seasonal variations in climate require that ACs run at part-load for a larger amount of time.

**Table 3-4 Market share of inverter driven (or variable speed compressor) split packaged ACs<sup>23</sup>**

Country	% inverter (date)	Data Type	Source
Australia	55.0% (2008)	Government Data	IEA 4E M & B, 2010
China	18.0% (2009)	Government Data	Baillargeon, 2011
EU	50.0% (2008)	Sales Average	Baillargeon, 2011
Japan	~100%		Baillargeon, 2011

---

<sup>23</sup> Data shown in table 3-4 are based on data summarized in the CLASP Mapping Report for China, EU, and Japan and from the IEA 4E Mapping and Benchmarking Analysis for Australia. (IEA 4E M&B, 2010 and Baillargeon, 2011)

### 3.5 Deployment of Reversible ACs varies with climate and habit patterns

Sales and penetration of reversible split packaged ACs varies significantly across the various countries studied with near universality in the Japanese market and no reversible ACs sold in the UAE. Clearly climate is a major driver of the availability of reversible units in many countries, but habit patterns and availability of other heating sources may also be driving this trend. The reversibility of ACs also affects how heavily ACs are used and thereby affects the cost-effectiveness of more efficient designs, i.e. increased usage leads to efficiency being more cost-effective.

**Table 3-5 Market Share of reversible (or cooling and heat pump) split packaged ACs<sup>24</sup>**

Country	% reversible
Australia	77.70%
Brazil	40.4%
Canada	41.8%
China	-
EU	65.0%
India	-
Japan	98.6%
Korea	11.1%
Mexico	15.5%
Russia	94.8%
South Africa	90.3%
UAE	0.0%

---

<sup>24</sup> Data shown in table 3-5 are based on data from the IEA 4E Mapping and Benchmarking Analysis for Australia, from BSRIA for Brazil, Canada, Mexico, Russia and South Africa, and from the CLASP Mapping report for the EU and Japan. Data were unavailable for China and India.

### 3.6 Room AC Sales in Emerging Economies are High and Growing Rapidly

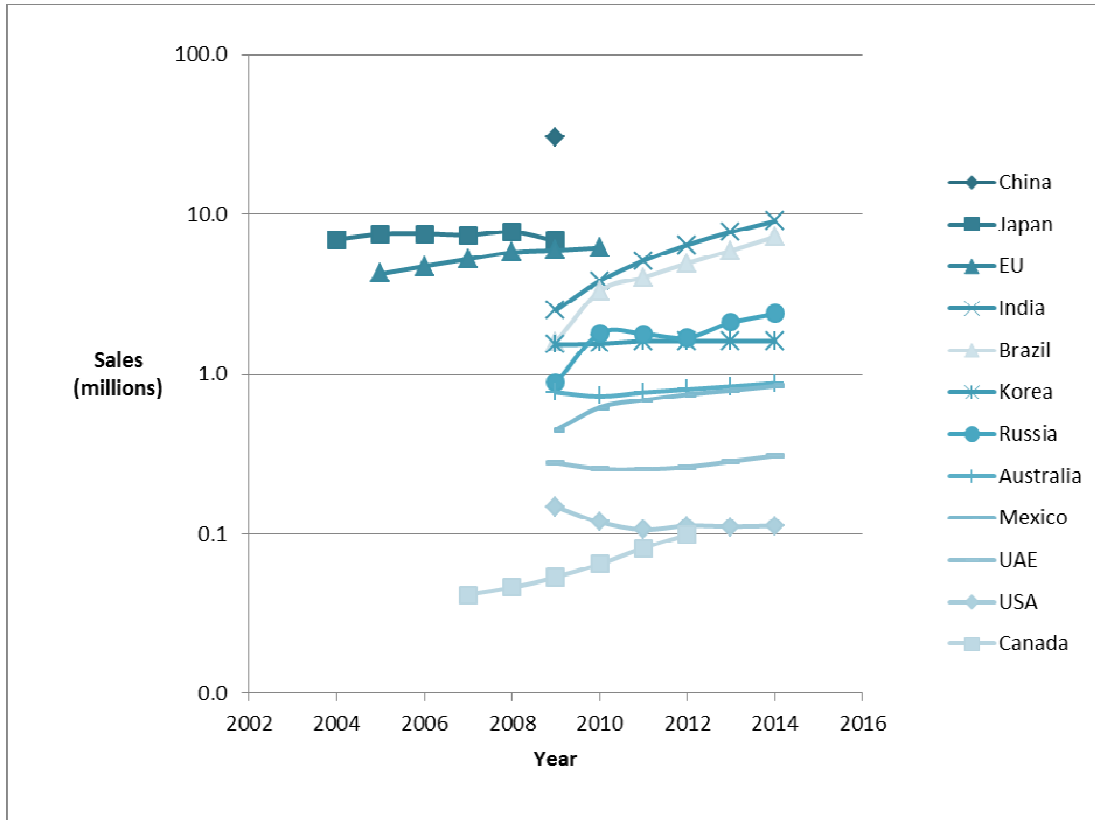

Figure 3-1 Current and projected AC Sales in various countries

Source: BSRIA, CLASP Mapping report (Baillargeon, 2011),

As shown in figure 3-1, Room AC sales in China, India, and Brazil are already high and expected to grow rapidly, in the next few years as incomes rise in these economies. Therefore any market transformation programs with a global or regional impact must take these large markets into account, when designing policies and programs, since these will undoubtedly have spill-over effects, even if only the market size is taken into account. The Japanese market is also large with annual sales of between 7-8 million units. Among the countries studied, Room AC sales are dominated by 5 economies (China, India, Brazil, Japan and the EU), with expected total 2014 sales of about 90% of the total market in the economies studied. The markets in the United States and Canada are dominated mostly by central ACs rather than split packaged ACs, which are the dominant type of Room AC globally.

### 3.7 Ongoing Development of Alternative Refrigerants

Currently, Room ACs along with other refrigerant using equipment use predominantly high-global warming potential (GWP), hydrofluorocarbon (HFC) refrigerants. In response to global HFC phase-down targets and proposals such as that made by the US, Canada and Mexico in 2010, the industry has begun developing equipment that uses low-GWP alternative refrigerants.<sup>25</sup>

The ideal refrigerant has the following characteristics:

- Non-toxic
- Non-flammable
- Zero Ozone Depletion Potential (ODP)
- Near-zero GWP
- High volumetric capacity

Four types of refrigerants have been identified as possible low-GWP alternatives to the most commonly used refrigerants today. These include:

- Low-GWP HFCs
- Hydrocarbons
- Carbon Dioxide
- Hydrofluoroolefins (HFOs)

Many of these alternative refrigerants suffer from one or more undesirable characteristics, such as greater flammability, toxicity, system efficiency or lower volumetric capacity than the HFC refrigerants. These concerns are even more relevant for Room ACs which are sensitive to *all* of these parameters due to their close proximity to the end user. Figure 3-2 illustrates the complexity of the decisionmaking process to select alternative refrigerants to HFCs, as none of the promising alternatives as yet identified has all the desired properties. (Rajendran, 2011)

Due to the long lead time and multiple tradeoffs involved in alternative refrigerant selection, the US Department of Energy (DOE) has developed a research and development “roadmap” to work with industry, researchers and stakeholders in identifying and developing next generation low-GWP refrigerants. (NCI, 2011)

---

<sup>25</sup> The United States, Canada, and Mexico announced a proposal in April 2010 to phase down consumption of HFCs by 85 percent during the period 2014-2033. “Proposed Amendment to the Montreal Protocol.” 30 April 2010. Open-ended Working Group of the Parties to the Montreal Protocol on Substances that Deplete the Ozone Layer: Thirtieth Meeting. Available online at: <http://www.epa.gov/ozone/downloads/HFCtext.pdf>.



	Current HFCs	Low GWP HFCs (R32)	HFO Blends	CO2	Hydrocarbons
GWP	~2000 to 4000	675	4-650	1	<10
Compressor Design & Cost	Low	Low	Low	High	Low/Medium
Energy Efficiency	High	High	High/Medium	Low/Medium	High/Medium
Flammability	Low	Low/Medium	Low/Medium	Low	High
Refrigerant Cost	Low	Low	High	Low	Low
System Cost	Low	Low/Medium	Medium	High	High/Medium

**Figure 3-2 Current (HFC) and possible future refrigerant alternatives (Source: Author's Interpretation from Rajendran, 2011)**

In addition to the development of alternative refrigerants there is also a need to develop metrics to evaluate the impact of such alternatives in a holistic sense, including both system efficiency and resulting GWP emissions (Indirect) and refrigerant leakage and the resulting GWP emissions (Direct). In response to this need, some researchers, such as Pham and Sachs, 2010 have suggested the use of metrics such as “Total Equivalent Warming Impact” (TEWI), to include such considerations in refrigerant selection, and have suggested that properly selected HFO blends may have lower TEWI than the currently dominant HFCs such as R410a.

There is clearly a need to identify alternative refrigerants that have lower environmental impact than the HFCs used currently. While a more comprehensive discussion of such alternatives is beyond the scope of this article, there are many forums such as the Montreal Protocol-related processes where international stakeholders, manufacturers, environmental groups and governments are continuing this exploration and development. Since the choice of alternative refrigerant has an impact on efficiency and on cost, as well as on other parameters (flammability, toxicity) that are important in Room ACs as consumer-facing products it would be useful for policymakers to align efficiency programs with such processes where possible and practical.

## Chapter 4 Cost Effectiveness Analysis

In this chapter we describe the methodology, assumptions, and results of the cost of conserved electricity (CCE) analysis which is used to assess the cost effectiveness of efficiency improvement options by comparing the CCE with the cost of supplying electricity. We briefly review the process used to estimate the costs of efficiency improvements from the design options discussed earlier in chapter 2, the cost-efficiency model, input data and assumptions, and present the results of this cost effectiveness analysis in the form of a cost-effectiveness curve for each economy studied. Figure 4-1 illustrates the steps in the cost effectiveness analysis

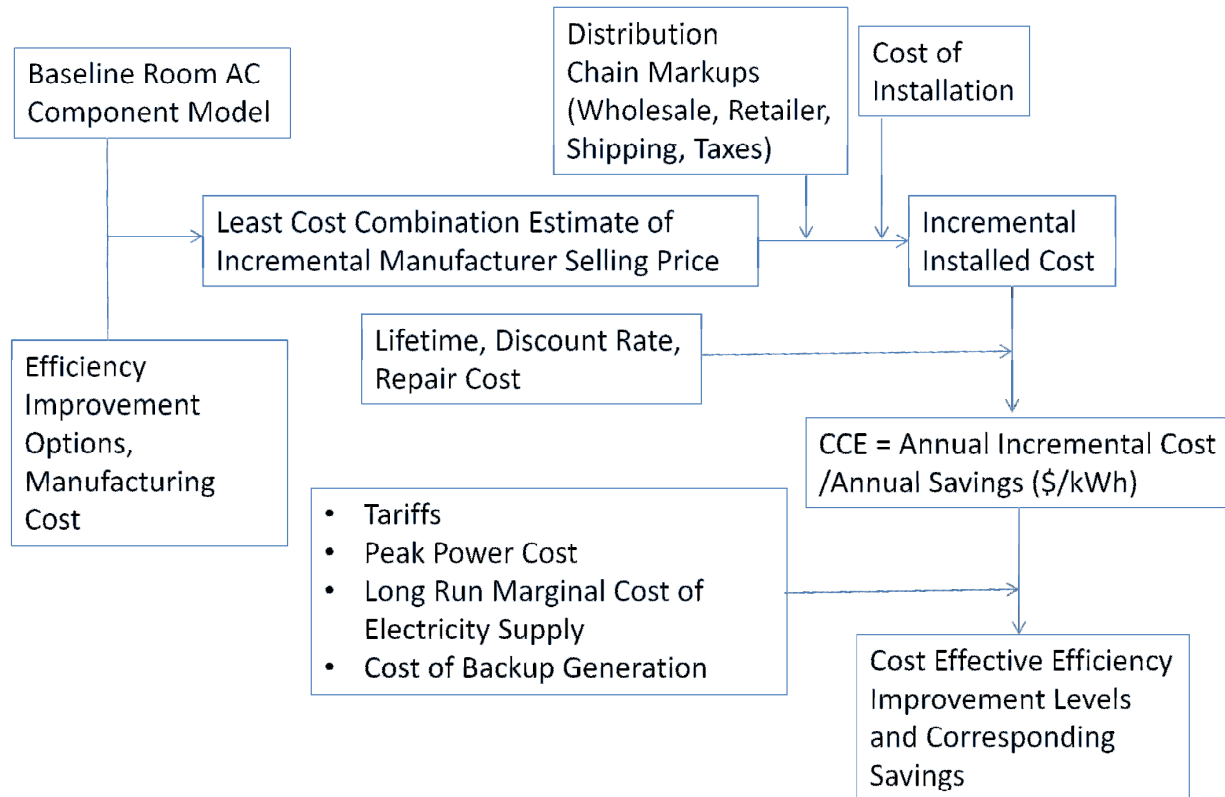

**Figure 4-1 Cost Effectiveness Analysis**

We created an engineering-economic model (described in this chapter) to calculate the energy efficiency changes and associated manufacturing costs from the application of higher efficiency design options to room air conditioners. We used the model to assess the impact of increasing room air conditioner energy efficiency on cost of conserved electricity in the following economies: Australia, Brazil, Canada, China, Europe, India, Japan, Korea, Mexico, Russia, the UAE and the USA.

Single packaged split room air conditioners dominate the global room air conditioner market and are by far the most commonly found room air conditioner technology in all markets except North America. As a result, we focus the techno-economic analysis on these products, as they represent the major share of the international room air conditioner market. Majority of split systems sold are reversible i.e. that they can be used to provide space heating as well as space cooling. It is a small design change to convert a cooling only

split system into a reversible unit so increasingly this is becoming the default option. In some economies, e.g. Japan, the energy used in heating mode by air conditioners is greater than it is in the cooling mode. Furthermore, the heating-mode efficiency correlates closely with the cooling-mode efficiency, as the design aspects affected efficiency are directly related in both cases. Thus any assessment of the impact of energy efficiency design changes on cooling performance should also consider the impacts on heating performance if the total cost changes are to be correctly determined. We consider the impact of higher efficiency options on both the cooling and heating modes and present the combined cost changes for the product as a whole.

While the efficiency at full load i.e. the energy efficiency ratio (EER) has been the most commonly used metric historically, most air conditioners only operate at full load for a small proportion of the time. The seasonal energy efficiency ratio (SEER) gives a better approximation of the annual average energy efficiency of a room air conditioner as SEER metrics are designed to account for performance during part load conditions occurring from time to time to produce a statistically representative metric of annual average energy efficiency. Currently such metrics are in place in Japan (called the Annual Performance Factor or APF) and the USA/Canada (known as the SEER). For this study we have chosen to use the new European Seasonal Energy Efficiency Ratio (ESEER), because unlike the other two metrics it also takes account of energy consumption in off and idle modes as well as energy used to keep crank cases warm in the heating system for reversible units and hence is likely to be more representative of performance of ACs when they are in use. Accordingly, all results in the report are reported in terms of the ESEER.

In this report we do not attempt to produce conversions showing the ESEER levels corresponding to SEER, APF or EER levels; however, this is possible using the benchmarks developed in the parallel CLASP project (Waide et al. 2011). All units reported are metric and all EER/SEER units are reported as W/W values. To convert these to nominally equivalent values in American units they should be multiplied by 3.413; however, it should be noted that the ESEER includes auxiliary energy loads while the US SEER does not.

Based on a combination of design options related to the components of a conventional split room air conditioning unit we calculate the energy efficiency ratio (EER), the seasonal energy efficiency ratio (ESEER) manufacturing and total cost for each combination.

The techno-economic analysis considers every possible combination of the design options to produce a “cloud” of energy efficiency/ cost pairs. At each energy efficiency level, the lowest cost option is selected to develop a cost versus efficiency curve.

Each combination of design option carries a cost, generally energy efficiency comes at a premium meaning that the cost of the unit increases with the unit’s EER. The findings are fully consistent with what is known about the options to increase energy efficiency of room air conditioners and the actual performance of products currently on the market; however, it should also be recognized that:

- We only consider higher efficiency design options known to the analytical team; there may be other options which are not widely known
- We assume that the current cost of implementing the higher efficiency design options does not evolve whereas in reality costs should decline through the “learning by doing” effect (also known as the experience curve) in the medium to long term, after economies of scale are realized, even though costs may go up in the short term

Both of these effects are likely to be significant and their importance should not be underestimated when considering potential policy opportunities and implications. For example, evidence from many decades of equipment standards and labeling programs has shown that the incremental costs projected by techno-

economic analyses of the type shown here are typically higher than the actual costs seen in the market (U.S. DOE 2011). We describe the design options considered for efficiency improvement next.

## 4.1 Room AC Components and Design Options

The energy efficiency design options applicable to improve the energy efficiency of room air conditioners are discussed in detail in chapter 2. For the economic cost of conserved electricity analysis we only consider:

- design options that can be directly applied within standard room air conditioner technologies currently on the market
- options that will show energy savings under the existing product energy performance test procedures
- options that can be integrated into current products (i.e. do not imply changing basic product configurations to include additional energy savings options as part of a system redesign)

Following on from the chapter 2 analysis the following room air conditioner features were considered for design improvements: compressor efficiency, compressor control, heat exchanger performance, expansion valves, crankcase heaters and controls, and standby power use<sup>26</sup>.

These design options are then grouped into option classes from A to F as follows:

- A = Compressor efficiency
- B = Compressor control
- C = Heat Exchanger
- D = Expansion valve
- E = Crankcase heater efficiency and Crankcase heater control
- F = Standby

Each component can be modified a finite number of times thus creating a design option; for A there are 3 options, B also 3, C 4, D 2, E 2 and F 1 (Table 4-1).

---

<sup>26</sup> Note the benefits from design improvements in the last two sets of options would not be reflected in other test procedures than the new EU test procedure prEN14825 and this is why this is selected for all analyses to determine probable changes in annual energy use and cost.

**Table 4-1: Design Option Description**

	<b>Base Case</b>	<b>Design Option 1</b>	<b>Design Option 2</b>	<b>Design Option 3</b>	<b>Design Option 4</b>
<b>A=0 to 3</b>	Base case compressor	Higher eff. compressor 1	Higher eff. compressor 2	Higher eff. compressor 3	
<b>B=0 to 3</b>	Single-speed compressor control	AC inverter	AC/DC Inverter	DC inverter	
<b>C=0 to 4</b>	Base case heat exchanger	Higher eff. heat exchanger 1	Higher eff. heat exchanger 2	Higher eff. heat exchanger 3	Higher eff. heat exchanger 4
<b>D=0 to 2</b>	No expansion valve control	Thermostatic expansion valve	Electronic expansion valve		
<b>E=0 to 2</b>	Base case crankcase heating and control	Reduced crankcase heating power	Reduced crankcase heating period		
<b>F=0 to 1</b>	Base case standby loads	Reduced standby loads			

Making these groupings ensures that combinations of design options are only applied when the design options for each component are exclusive and independent of the other options for that component. For example a change in compressor efficiency must not relate or affect the value in a previous option for compressor efficiency (all design options in group A) but the savings will interact with those from other design option groups (groups B to F). Thus, for each design simulation at least one value from each of group A, B, C, D, E and F must be chosen and simulated. Overall this leads to 1,728 combinations of design options and hence an equal number of pairs of manufacturing cost vs. ESEER values. These results were produced and plotted to form a “cloud” of data points as shown in figure 4-1 below and post processed using specially designed software code to determine the least cost choice at each energy efficiency level. Both sets of results are reported in section 4.4.

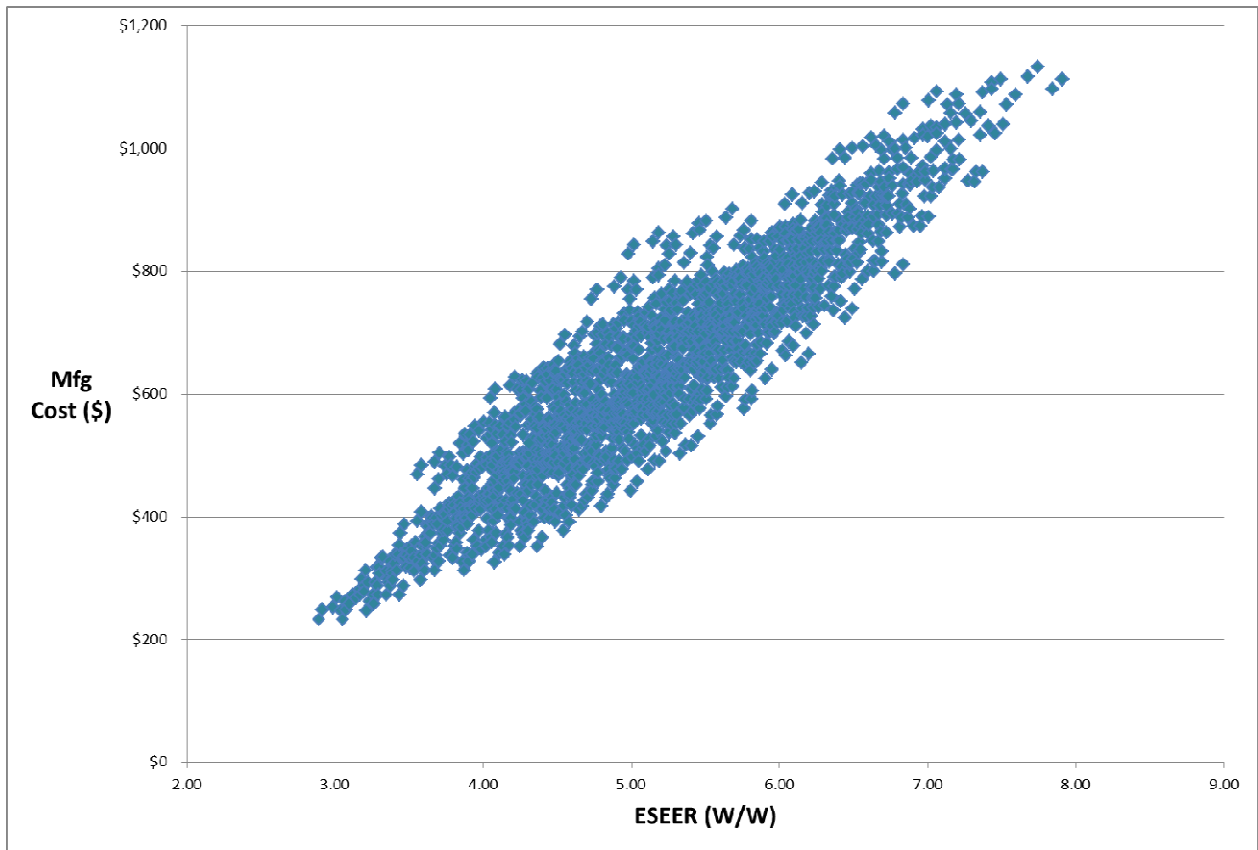

Figure 4-2 “Cloud” of 1728 Cost-ESEER pairs

## 4.2 Cost-Efficiency Model Methodology

The model applied to simulate the impact of each energy efficiency design option is the same one used for the EU’s Ecodesign Lot 10 study and is an adapted version of the Oak Ridge National Laboratory model that has previously been applied to similar analyses in the USA for the USDOE.

The analysis makes use of the energy efficiency incremental component costs and efficiency improvements developed under the European Commission’s Ecodesign program Lot 10 study. This analysis was recently completed and has the latest cost component data. Base case and incremental component cost data used in the Lot 10 study was derived from extensive engagement with manufacturers and other industrial experts.

We have used the same base case model developed for the EU Lot 10 study, which is a fixed speed compressor unit with the following characteristics.

**Table 4-1: Base Case Model Performance Characteristics**

<b>FULL LOAD (T1)</b>	<b>Value</b>	<b>Units</b>	<b>Description</b>
Pcfl 35	3.5	kW	Pcfl = cooling capacity power at full load
Pefl 35	1.21	kW	Pefl = electric power load at full load
EERfl 35	2.89	W/W	EERfl = energy efficiency ratio at full load
<b>PART LOAD</b>			
Min capacity	100%		
Min cap EER	100%		
Cd	0.2		Cd = the part load degradation coefficient
Pto	0.036	kW	Pto = power demand with thermostat off
<b>OFF LOAD</b>			
<i><b>Power</b></i>			
Pto	0.17	kW	Pto = power demand with thermostat off
Psb	0.006	kW	P <sub>sb</sub> = standby power demand
Poff	0.006	kW	Poff = off-mode power demand
Pck	0.03	kW	Pck = crank case heater power demand
<i><b>Hours</b></i>			
Hto	221	H	Hto = hours spent with thermostat on
Hsb	2142	H	Hsb = hours spent in standby mode
Hoff	0	H	Hoff= hours spent in fully off mode
Hck	2672	H	Hck = hours spent with crankcase heater on

This unit is very typical of fixed speed split systems found around the world but is not the least efficient kind of product one can find on the market and is close the market average efficiency seen in most market. Thus it should be understood that the analysis starts from a mid-market point for much of the world Room AC market.

Once the base case is simulated, successive design changes are simulated such that all possible mutually inclusive options have been simulated leading to 1728 simulations per economy.

The efficiency gains associated with these options depend on the seasonal load characteristics assumed and hence depend on the climate and usage factors. These are treated for each economy using known data sources on total hours of usage (in both heating and cooling models) and climate. The percentage annual energy savings compared to the base case from applying each of the design options individually in Europe is shown in Table 4-4. Please note that Table 4-4 applies to the climate in the European Union only.

**Table 4-2: Energy Savings for Individual Design Options Compared to the Base Case Model Used in the European Union**

Design option	Energy saving compared to the base case
A1	6.5%
A2	12.3%
A3	18.7%
B1	20.0%
B2	20.7%
B3	24.8%
C1	9.1%
C2	16.0%
C3	21.3%
C4	24.8%
C5	28.6%
D1	5.0%
D2	8.8%
E1	9.8%
E2	10.7%
F1	2.2%

To produce the cost estimates, we consider the following costs and mark-ups

- The factory gate cost of the appliance
- The supply chain mark-ups from factory gate to final customer
- The costs of installation
- Maintenance costs
- Energy costs
- Costs of capital

The factory gate costs are determined by applying a bill of materials for each component used, general production and labor overheads, sales and general administration costs and producer mark-ups. Supply chain mark-ups are determined from the literature and/or by comparing retail prices with estimated factory-gate prices (this is done by screening on-line catalogue price comparisons as a function of product efficiency).

Installation costs are taken from the literature or expert contacts. Energy costs are derived from official statistics on tariffs and capital costs are determined by assuming a real discount rate 2% higher than the inflation adjusted prime interest rate in each economy.

In order to calculate the cost of a component of a split air conditioner, the whole unit is first divided into its



components:

- Compressor
- Condenser
- Evaporator
- Outdoor fan
- Indoor fan
- Working fluid
- Expansion valve
- Refrigerant line
- Liquid receiver
- Controller + electricity
- Casing
- Others (Packaging, accessories, manual)

Next the component is given a percentage value which denotes how much of the total cost of the air conditioner it represents, for example the compressor represents 26% of the total cost. Then by using the known cost of a typical room air conditioner each component is given a cost based on its percentage share. As each higher efficiency design option is applied it is assumed to have an incremental cost associated with it. These costs are taken from the analysis used in the EU Lot 10 study. The part of these incremental costs attributable to labor costs will vary by region and thus these are allowed to vary from one economy to the next. We estimate the CCE based on the following steps as shown in Figure 4-1 earlier:

- Manufacturing cost
- Installed cost
- Cost of Conserved Electricity

The manufacturing cost is calculated by taking the known manufacturer cost and adding the combination of prices attached to each design option. As seen in the example presented in Figure 4-3 below, improving the efficiency of room ACs adds to their manufacturing costs which results in a corresponding increase in their retail price. For example, a 32% improvement in ESEER from 4.06 to 5.36 increases the manufacturing cost by \$ 106 and the retail price by \$ 182. (~32% increase). The manufacturing costs of room ACs for various economies are presented in Appendix B.

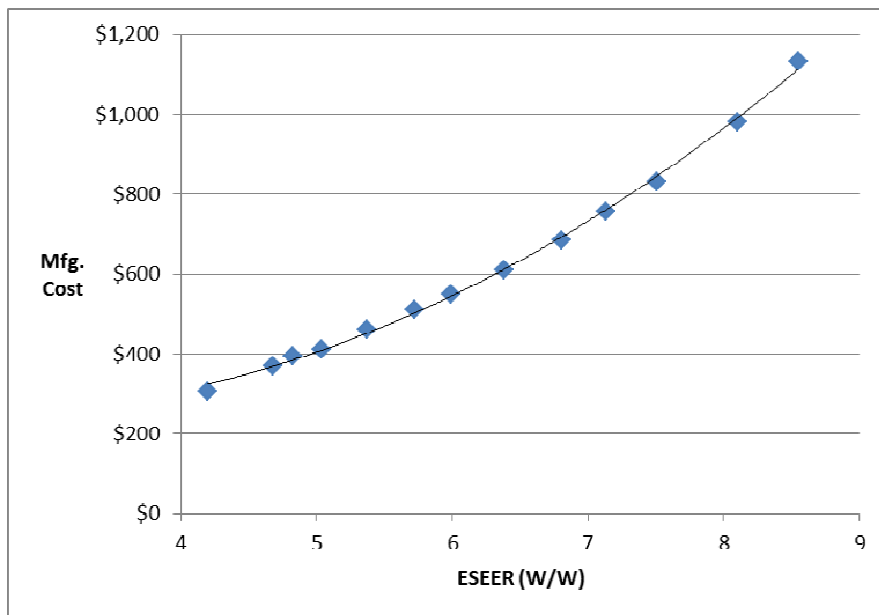

**Figure 4-3 Example of Manufacturing Cost versus ESEER Curve for Australia**

The installed cost is made up of; manufacturing costs, the manufacturers selling price, installer margin and tax. In the model these are represented using a set of multipliers which represent the mark up from the original manufacturer's cost.

The cost of conserved electricity is calculated using the installed cost, the discount rate, the life duration of the product, the energy tariff and the maintenance cost for the base case model and for each efficiency improvement level as discussed further in section 4.2.1.

### 4.3 Other Data Inputs

Electricity price data is collected from:

- US Energy Information Administration (EIA)
- EU Energy Portal
- The International Energy Agency (IEA) Electricity Information 2010
- The IEA Key World Statistics 2010
- Government of India, Ministry of Power, Central Electricity Authority ([www.cea.nic.in](http://www.cea.nic.in))
- LBNL data for China and India

The statistics are gathered and converted into USD and Euro for comparison work. The rates used in the analysis are a country specific blend of domestic and commercial rates from 2009. The weighting is calculated based on the BSRIA table showing percentage sales of single and multi-split air conditioners to the residential market. Where this data could not be assumed a weighting of two thirds residential to one third commercial has been assumed. The 2009 commercial rate is calculated using a blend of 2009 domestic (2/3) and industrial rates (1/3).

**Table 4-3: Electricity Prices including Weighting (\$ per Kilowatt hour)**

	Residential Rate	Commercial Rate	Blended Rate	Weighting (Residential to Commercial)
Australia	\$0.11	\$0.07	\$0.08	60:40
Brazil	\$0.14	\$0.13	\$0.14	60:40
Canada	\$0.06	\$0.06	\$0.06	78:22
China	\$0.06	\$0.09	\$0.07	66:33
EU-27	\$0.15	\$0.13	\$0.14	66:33
India	\$0.03	\$0.06	\$0.05	50:50
Japan	\$0.16	\$0.15	\$0.16	66:33
South Korea	\$0.06	\$0.05	\$0.05	85:15
Mexico	\$0.06	\$0.06	\$0.06	80:20
Russia	\$0.04	\$0.05	\$0.05	42:58
South Africa	\$0.06	\$0.05	\$0.05	83:17
United States	\$0.08	\$0.07	\$0.08	66:33
United Arab Emirates	\$0.05	\$0.05	\$0.05	75:25

Labor statistics are collected from:

- The Office of the Economic Advisor, Ministry of Commerce and Industry
- China Statistical Yearbook
- International Labor Office (ILO) Department of Statistics, ILO Database
- Organization of Economy Co-operation and Development (OECD)
- Bureau of Labor Statistics (BLS)

We selected data from the ‘manufacturing’ labor category for the model. Figures are given in terms of earnings per hour, per month and per employee. Data timelines ranged from 2000 to 2009. Accurate and current labor data was challenging to source, particularly for Russia, South Africa and the UAE. As such, it was difficult to complete accurate comparison work without using a forecasting tool on the data we could find in those countries.

AC usage data is gathered from national sources for each economy where available.

#### **4.4 Cost Effectiveness Analysis using the Cost of Conserved Electricity**

The cost-effectiveness metric used in the analysis presented here is the cost of conserved electricity (CCE), which is calculated by dividing the incremental cost of a design change by the incremental energy saved by the design change. The design change is considered with respect to a design corresponding to the market average

efficiency level in each economy. We calculated two types of CCE and discuss the calculation method, market transformation program design using the cost-effectiveness analysis and the results of the cost effectiveness analysis next. We discuss briefly the impact of technological learning on cost-effectiveness of efficiency improvements in section 4.2.4, and present a sensitivity analysis of our results to the assumptions in Appendix D.

#### 4.2.1 Cost of Conserved Electricity Methodology

Two kinds of costs of conserved electricity are calculated as follows: a) the cost to the manufacturer of conserved electricity, ( $CCE_m$ ), which considers the incremental cost of the higher efficiency model at the factory gate i.e. to the manufacturer and b) the cost to the end user or consumer of conserved electricity, ( $CCE_c$ ), which considers the incremental cost of the higher efficiency model to the consumer or end user, i.e. considering retail prices. The former metric ( $CCE_m$ ) is lower than the latter ( $CCE_c$ ) as it does not include markups and installation costs. Therefore,  $CCE_m$  can be used to measure the cost-effectiveness of a market transformation program such as an upstream incentive program, while  $CCE_c$  would be used to measure the cost effectiveness of a standards program.

The Cost of Conserved Electricity of CCE is then calculated for each economy at various efficiency levels as follows:

$$CCE = \text{Annualized incremental cost of efficient AC (\$)} / \text{Annual power saved by efficient AC (kWh)}$$

i.e.  $CCE_m = \text{Annualized Incremental cost to manufacturer of efficient AC (\$)} / [(\text{Annual electricity consumed by average AC}) - (\text{Annual electricity consumed by efficient AC})]$  (kWh)

and  $CCE_c = \text{Annualized Incremental cost to consumer of efficient AC (\$)} / [(\text{Annual electricity consumed by average AC}) - (\text{Annual electricity consumed by efficient AC})]$  (kWh)

#### 4.2.2-Incremental cost of efficiency improvement

#### 4.2.2 Using Cost of Conserved Electricity for Market Transformation Program Design

Governments could use data such as the cost of conserved electricity results presented here in sections 4-4 and 5-3 below to design programs such as standards programs at efficiency levels corresponding to the point where costs of conserved electricity are equal to the benefit of saving electricity from the perspectives of various stakeholders. We will discuss these perspectives and their corresponding cost-effective potential next.

In order to assess whether these extra manufacturing costs and corresponding increases in retail prices for saving electricity are cost effective, we compare them with the benefits of saving electricity, i.e. typically the cost of electricity used by the consumer. The cost and benefit of saving electricity varies with the stakeholder (consumer, utility, electricity sector, and society at large). For example, the cost to the consumer is the increase in the AC retail price whereas the benefit is the savings in the electricity bill which depends on their electricity tariff.

In this analysis the cost effectiveness of efficiency improvement options and the corresponding savings potential is assessed by comparing the cost of conserved electricity (CCE) for these options with the cost of electricity. For most purposes,  $CCE_c$ , which uses retail prices, is the cost-effectiveness metric that is used. We estimate the CCE at different levels of efficiency improvement corresponding to the classic options discussed in section 2.3.1 and further discussed in section 4.1 and 4.2 earlier. These design options and their corresponding costs and efficiency benefits are assessed up to the technical potential, i.e. the level of

efficiency achievable using the best available technology that is currently feasible.

The percentage efficiency improvements and corresponding energy saving potential that is cost effective is estimated by comparing the CCE with cost of electricity suitable for the perspective for which the cost effective potential is estimated. Efficiency improvement policies and programs often attempt to correct market failures in facilitating the adoption of cost effective energy saving potential. The information presented in sections 4-4 and 5-3 can be used to inform the design of these programs.

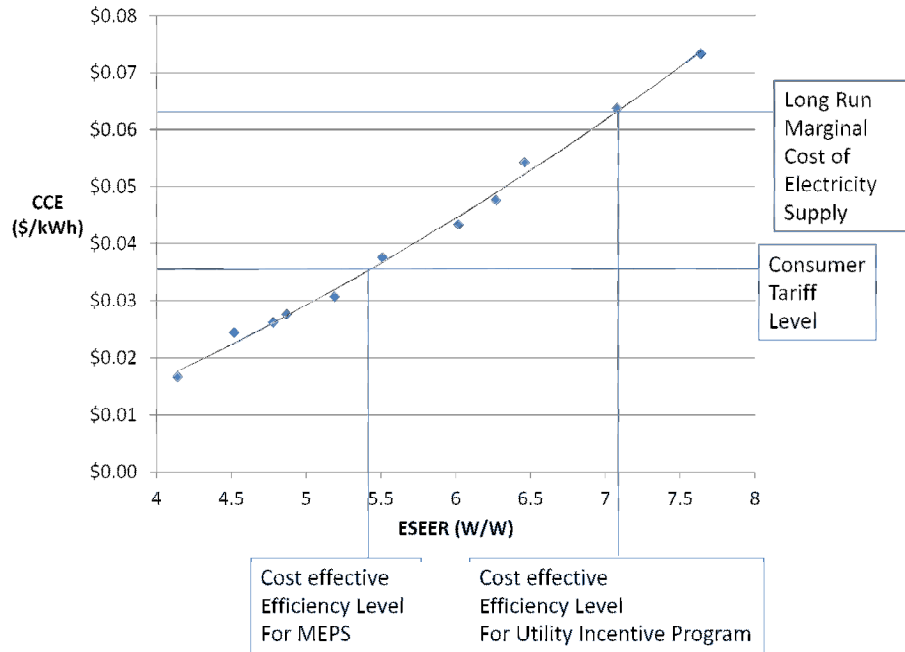

**Figure 4-4 Market Transformation Program Design Example**

**Cost Effectiveness- Consumer Perspective:**

The cost effective efficiency level and corresponding savings potential from the consumer perspective can be estimated by using the consumer tariffs as the cost of electricity. For example, as shown in Figure 4-4, for setting minimum standards,  $CCE_c$  can be compared with the consumer electricity tariff. A standards program looking at cost effectiveness from a perspective focused on cost-effectiveness to the consumer can use the metric of consumer electricity tariff  $\geq CCE_c$  to determine the level of efficiency improvement and corresponding savings that are cost effective to the consumer.

**Cost Effectiveness – Utility Perspective:**

The cost effective efficiency level and corresponding savings potential from the perspective of a utility can be estimated by using the long run marginal cost (LRMC) of electricity supply at the time when ACs are operating (which is often during peak electricity demand periods), as the cost of electricity. For example, as shown in Figure 4-4, the efficiency level that can be targeted by a utility incentive program, could be at a where CCE is less than or equal to the long run marginal cost of electricity supply i.e.  $LMRC \geq CCE_c$ .

Further, if the incentive is provided upstream, even higher levels may be targeted as the mark-ups and taxes may be avoided compared to a downstream incentive if such benefits are passed through the supply chain to the consumer. In such cases, the CCE can be estimated based on incremental manufacturing costs and the efficiency improvements targeted is where  $LMRC_{peak} \geq CCE_m$ . The actual amount of the incentive could be set at the incremental cost to the manufacturer or some fraction of this cost. Such costs could be calculated for each economy using the manufacturing cost data presented in Appendix B.

### **Cost Effectiveness – Societal Perspective:**

The cost effective efficiency level and corresponding savings potential from a societal perspective can be determined by including costs such as the costs of peak load, power outages, and backup generation as well as the environmental cost of electricity generation to the cost of the LRMC peak to determine the cost of electricity supply to society as a whole. From this perspective, even higher efficiency levels could be targeted to avoid imposing these costs on society. If cost effectiveness is considered from this perspective, Cost of Electricity Supply to Society =  $CCE_m$ . This is the widest, most inclusive, definition of cost effectiveness, and could be targeted by programs promoting the “top of the market” such as categorical labels, awards, procurement and incentive programs.

Integrated market transformation programs that target different levels of the market can be designed using the information presented here. The total CCE versus efficiency curves presented in the next section offer flexibility in designing integrated programs that can target different potentials depending on the perspective of the policymaker.

4.2.3 Cost Effectiveness Analysis Results

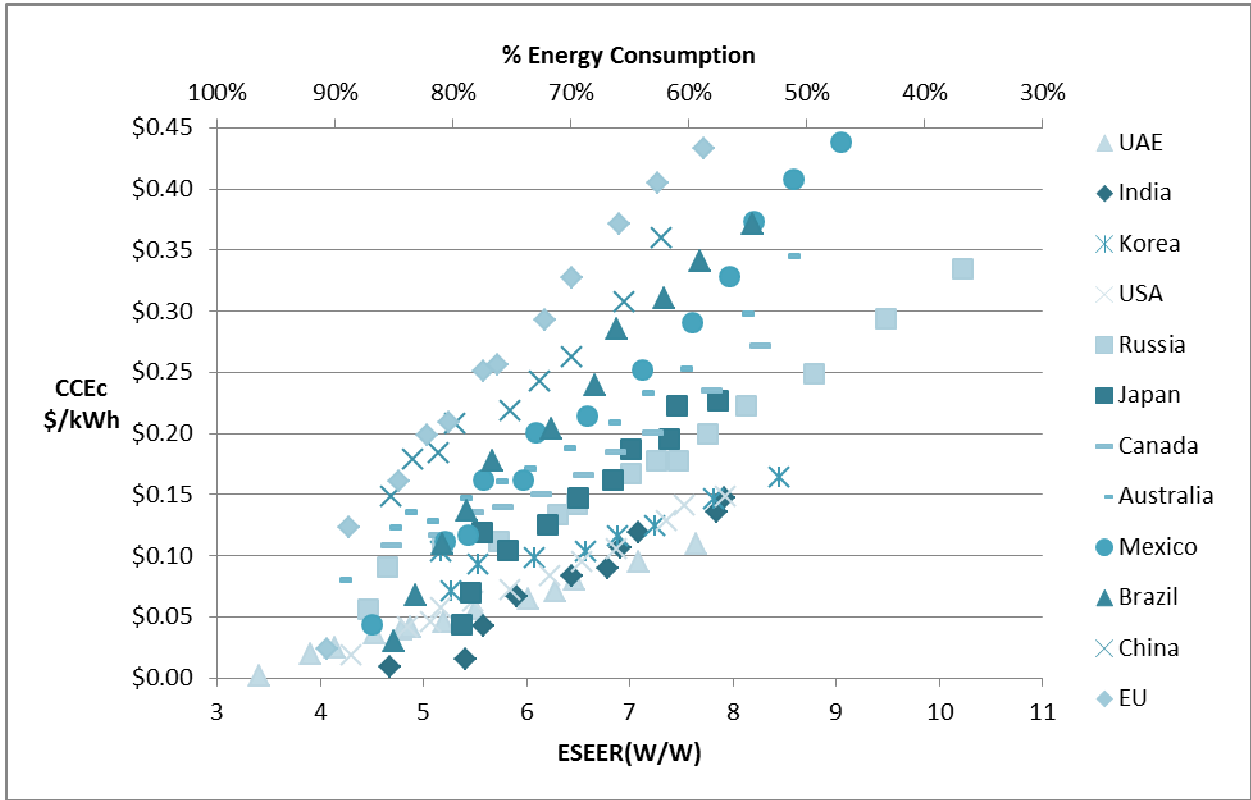
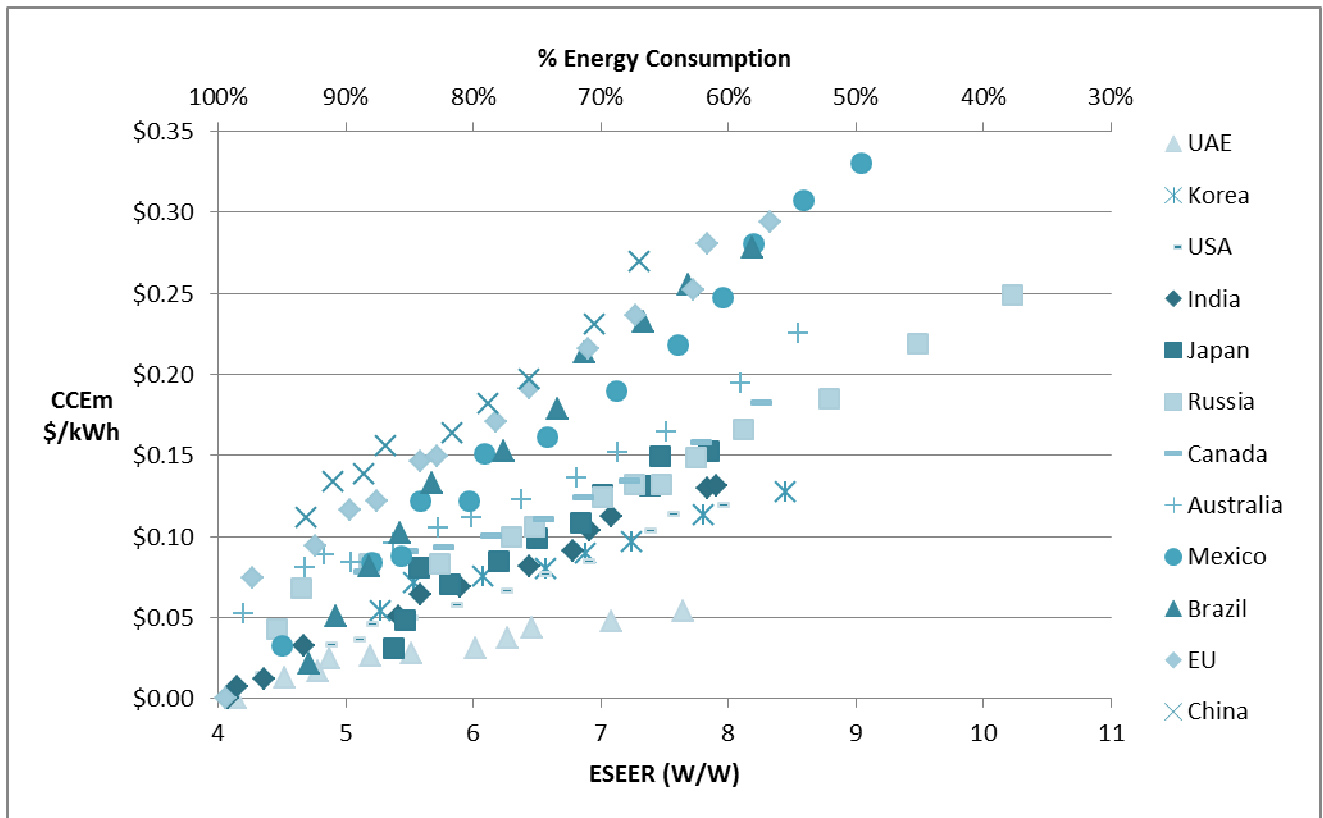

Figure 4-5 Cost (to consumer) of Conserved Electricity (CCEc) Versus Room AC Efficiency for Various Economies

As shown above in figure 4-5, for most economies ESEERs of over 6 W/W are attainable at costs (to the consumer) of conserved electricity between 5 and 15 cents per kWh. In economies with a higher cost of capital (i.e. discount/interest rates) such as Brazil, or low hours of use such as Mexico or China, higher efficiency ACs carry a larger cost of conserved electricity, when compared to India or UAE. For countries such as Japan where ACs are used for both heating and cooling, and India or UAE, where ACs are used for many hours annually, very high ESEERs are attainable at low cost per unit of electricity saved.



**Figure 4-6 Cost (to manufacturer) of Conserved Electricity (CCEm) Versus Room AC Efficiency for Various Economies**

Figure 4-6 shows the cost (to the manufacturer) of conserved electricity versus efficiency, where the markups and incremental costs of installation and maintenance which are also incurred by the consumer are not included. Thus  $CCE_c$  is usually higher for the same efficiency level compared to  $CCE_m$ . Therefore the efficiency levels reached using this metric are correspondingly higher at the same cost. We discussed the use of these cost-effectiveness metrics for energy efficiency program design in the previous section.

#### 4.2.4 Price Learning

The economic analyses presented in this chapter do not consider any form of price or efficiency learning, in order to be conservative in terms of cost-effectiveness. However, for the sake of comprehensiveness, we discuss briefly the recent literature on price learning of air conditioners.

The experience curve is an empirical model based on historical data fits of price and/or cost data to cumulative production. This model has been applied to a wide range of products (DOE 2011). Although “experience curves” and “learning curves” have identical mathematical forms, they represent different perspectives that are relevant to studies of different scope. According to (DOE 2011), learning curves are generally used when the study focuses on worker and management “learning” that reduces labor hours for a single standardized product from a single manufacturer. Experience curves usually focus on broader classes of products, e.g., all refrigerators, which may encompass many models built by many manufacturers. Because



of the range of Room AC models considered, we focus on learning rates from “experience curves” for Room ACs here.

### Learning Rates for ACs

Weiss et al (2010) conducted a review of the literature on learning rates derived from experience curves for various energy demand side technologies and found that six studies conducted historically on learning rates in air conditioners reported an *average learning rate of over 15%*, with the range being just over 8% up to 22%. i.e. the price of air conditioners dropped on average by 15% with every doubling of air conditioner production, based primarily on shipment data in the US market, with one study on the Japanese market. While it is difficult to generalize these results to the global market, it is evident from the literature that increased production does significantly reduce the prices of air conditioners. i.e. in this case Room ACs. Thus policies designed to promote more efficient Room ACs, if successful will probably see a corresponding drop in the prices of such air conditioning technology.

## Chapter 5 Energy Saving Potential

Room ACs efficiency improvements account for 5-7% of total cost effective energy savings from possible cost-effective appliance efficiency improvement programs considered in a recent LBNL study (Letschert et al, 2012). In this chapter we describe our data sources, methodology and estimates of energy savings potential from higher efficiency of Room ACs for the various economies. We also discuss the energy savings potential of cost-effective market transformation programs in each economy. We will discuss briefly the impact of the rebound effect on energy savings in appendix C, and a sensitivity analysis of the energy savings to our assumptions in Appendix D.

### 5.1 Savings Potential Methodology and Data Sources

Room AC shipment data and forecast from BSRIA, the CLASP Mapping Report (Baillargeon, 2011), the EU Ecodesign data were used for the economies studied. To estimate future savings sales have to be forecast. We used the sales forecast from LBNL's BUENAS model (McNeil et al. (2013) in order to determine the growth rate of sales after 2014. Table 5-1 summarizes the Room AC shipment/sales data inputs.

**Table 5-1 Room AC Sales by country**

Country	Sales in 2009 (Millions)	Sales in 2014 (Millions)
Australia	0.9	1
Brazil	1.6	7.2
Canada	0.05	0.1
China	34	41.7
EU	15.8	19.3
India	1.7	6.1
Japan	6.8	7.2
Korea	1.6	1.7
Mexico	0.3	0.4
Russia	0.9	2.4
US	0.11	0.13

Source: McNeil et al. (2013), Letschert, (2009), BSRIA

In order to estimate savings we assumed a “base case” from the market data presented in chapter 3 using the average EER converted to average ESEER and average capacity reported in each market. Assuming any

market transformation policy or program targeting more efficient Room ACs begins in 2012, we estimated annual energy savings potential from more efficient Room ACs in each economy in 2020. All energy and emissions savings are calculated with respect to the “base case” in the corresponding market.

## 5.2 Energy Savings Potential

The energy savings potential of more efficient ACs at various efficiency levels is presented in Figure 5-1 below. The energy savings potential is highest in countries with a large market such as China, India and the EU, and least expensive in countries with the highest annual use, such as India and the UAE. Countries with smaller split-packaged AC markets such as the United States, and Canada have the smallest savings potential. All the economies other than the United States and Canada have significant energy savings potential from Room ACs at low cost of conserved electricity, with China saving annual energy of about 33 Rosenfelds.<sup>27</sup> China, India, the EU, and Japan all have very significant energy savings potential from Room AC market transformation programs.

---

<sup>27</sup> In line with Koomey et al. 2010, we use the unit of Rosenfeld for denoting energy savings. One Rosenfeld=3Twh/year, or approximately one 500MW (i.e. medium-sized power plant).

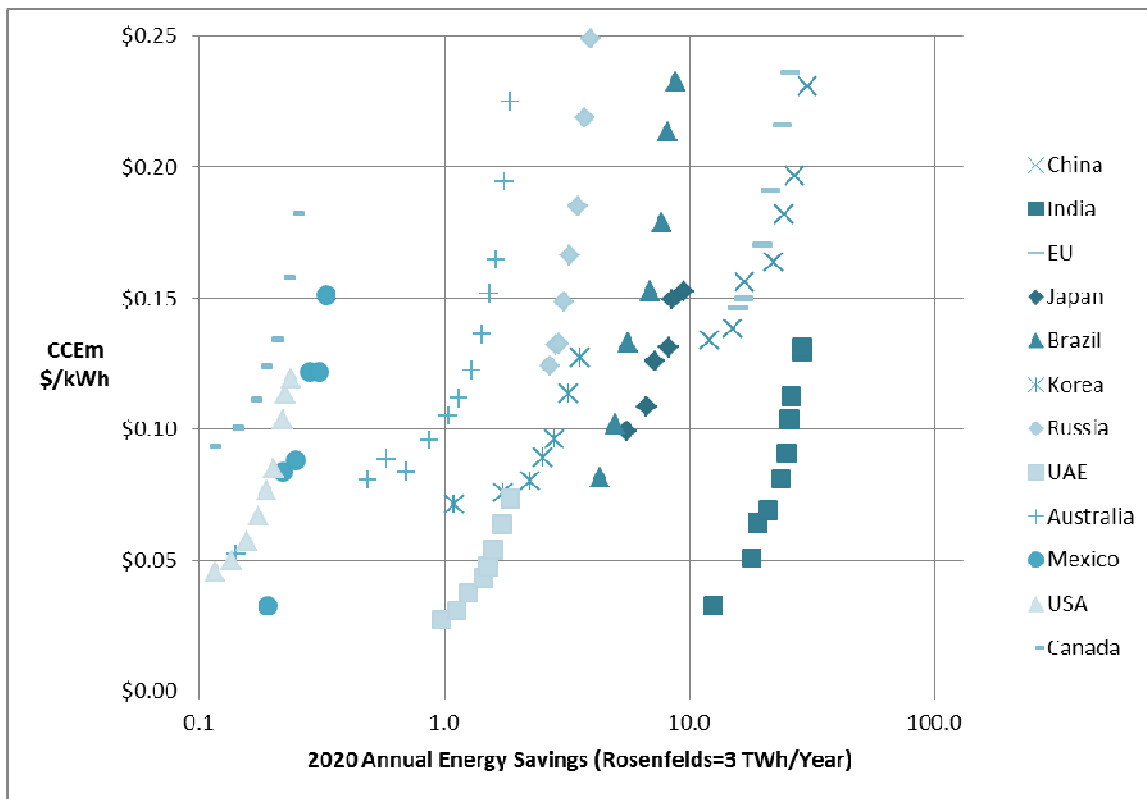

Figure 5-1 Cost of Conserved Electricity versus Annual Energy Savings in 2020.

### 5.3 Cost Effective and Total Energy Savings Potential

A	B	C	D	E	F	G	H
Country	Tariff \$/kWh	Market Average ESEER	Economic Potential ESEER (W/W) @ Tariff = CCEc	Technical Potential Max ESEER (W/W)	2020 Energy Savings @ Economic Potential (Rosenfelds)	2020 Energy Savings @ Technical Potential (Rosenfelds)	2020 CO2 savings @ Technical Potential (tons/year)
Australia	0.10	4.03	4.48	8.55	0.35	2	4
Brazil	0.19	4.05	5.67	8.83	6	10	3
Canada	0.08	4.58	4.54	8.26	0	0.24	0.1
China	0.19	4.11	5.19	7.30	16	33	99
EU	0.19	4.09	5.00	8.33	11	30	32
India	0.08	3.56	5.55	7.91	19	29	78
Japan	0.22	5.21	7.44	7.85	8	9	11
Korea	0.07	4.80	5.33	8.45	1	4	5
Mexico	0.08	3.71	4.45	9.74	0.15	1	1
Russia	0.05	4.20	4.20	10.23	0	4	4
UAE	0.07	3.46	6.24	7.64	2	2	3
USA	0.11	3.87	6.80	8.00	0.2	0.24	0.4
Total					64	123	241

**Table 5-2 ESEER and Energy Savings at Economic and Technical Potential**

In the above table 5-2, we present the following information:

- Column B: representative consumer tariffs for the economies studied.
- Column C: the approximate market average ESEER converted from the EER values reported in chapter 3.
- Column D: the economic or cost effective potential in terms of ESEER i.e. at efficiency levels where cost of conserved electricity equals the tariffs in column B.
- Column E: the total or technical potential in ESEER terms, i.e. the ESEER possible by deploying the best available technology in the climate and seasonal conditions of the respective economies.
- Column F: the 2020 annual energy savings potential from Room AC efficiency improvement in Rosenfelds (3TWh/yr), assuming that the corresponding market transformation program goes into effect at the efficiency level corresponding to column D and transforms 100% of the market. i.e. a standard corresponding to column D.
- Column G: the 2020 annual energy savings potential from Room AC efficiency improvement in Rosenfelds (3TWh/yr), assuming that the corresponding market transformation program goes into

effect at the level corresponding to column E and transforms 100% of the market. i.e. the potential available for a labeling or incentive specification corresponding to column E.

- Column H: the 2020 annual CO<sub>2</sub> savings potential from Room AC efficiency improvement assuming that the corresponding market transformation program goes into effect at the level corresponding to column E and transforms 100% of the market. i.e. the potential available for a labeling or incentive specification corresponding to column E.

The total 2020 energy savings potential from standards that is cost effective from a consumer perspective is about 64 Rosenfelds, i.e. Equivalent to 64 medium sized power plants(or 192 TWh/year), while the total technical potential is about 123 Rosenfelds, i.e. about 123 medium sized power plants (or 369 TWh/year).

If the costs of peak power, backup generation or power outages are included in the consideration of cost-effectiveness, due to the high peak coincidence of Room AC use, the ESEER levels that would be considered to be cost effective would be even higher than those shown in column D, along with correspondingly higher savings.

## Chapter 6 Conclusions

Based on the analysis presented in this report and discussed above, Room AC energy efficiency improvement offers significant opportunity for cost-effective energy efficiency improvement over 64 medium sized power plants (i.e. 192 TWh/year). We summarize conclusions that are relevant for policymakers to design effective Room AC energy efficiency market transformation programs below, as follows:

### Technical Data Can Be Used for Integrated Market Transformation Program Design

Governments could use data such as the cost of conserved electricity results presented earlier in sections 4-4 and 5-3, and the manufacturing costs presented in Appendix B to design programs such as standards, labeling or incentive programs at efficiency levels corresponding to the point where costs of conserved electricity are equal to the benefit of saving electricity from the perspectives of various stakeholders. The total CCE versus efficiency curves presented in the next section offer flexibility in designing integrated programs that can target different potentials depending on the perspective of the policymaker.

### Cost-effectiveness Metrics Could be Expanded

Metrics of cost effectiveness that drive energy efficiency policymaking could be expanded beyond a narrowly construed consumer cost-effectiveness perspective. For example, such metrics could account for subsidies, the cost of peak power, the costs of backup generation, or the costs of power outages. The cost effectiveness data presented in chapter 4 of this report could be used to design programs with such expanded considerations of cost-effectiveness, and therefore correspondingly higher efficiency levels. While expanded metrics could also be used across multiple product categories, such expanded metrics are particularly relevant for AC use due to the high contribution of ACs to peak loads, power outages and backup generation.

### Low GWP/ODP Refrigerants Can Have a Cost and Efficiency Impact

Through the Montreal Protocol and related processes, the Room AC industry is developing lower GWP refrigerants to phase out high GWP, HFC-based refrigerants. This next generation refrigerant development process has many tradeoffs as discussed in section 3.7, including tradeoffs with cost and energy efficiency, thus all three issues (cost, efficiency, and low ODP/GWP) need to be addressed in an integrated fashion.

## Acknowledgments

This work was funded by the Bureau of Oceans and International Environmental and Scientific Affairs, U.S. Department of State, and administered by the U.S. Department of Energy in support of the Super-efficient Equipment and Appliance Deployment (SEAD) initiative<sup>28</sup> through the U.S. Department of Energy under Contract No. DE-AC02-05CH11231. Michael McNeil, Virginie Letschert and Jing Ke of Lawrence Berkeley National Laboratory data for the Room AC sales forecasts from the BUENAS model. Helpful comments were provided on this report by Alex Lekov of Lawrence Berkeley National Laboratory's Appliance Standards Group, Steve Pantano, Neal Humphrey, and Ana Carreno of Collaborative Labeling and Appliance Standards Program (CLASP), Aditya Chunekar of Prayas Energy Group, Chris Stone of the Airconditioning, Heating and Refrigeration Institute (AHRI), Bonn Maguire of the Department of Climate Change and Energy Efficiency of Australia, Kang Hee Jeong from the Korea Refrigeration & Air-Conditioning Assessment Center (KRAAC), and Sung Hyuk Hong from LG Electronics. Nicole Kearney of Collaborative Labeling and Appliance Standards Program (CLASP) provided invaluable formatting and editing assistance to get this report in its final format. Any errors or omissions are the authors' own.

## References

ACESS, 2008, Final Report, Air Conditioner Evaluation Standard Subcommittee, Energy Efficiency Standards Subcommittee of the Advisory Committee for Natural Resources and Energy

Akhlaghinia et al., 2008: M.J.Akhlaghinia, A.Lotfi, C.Langensiepen, N.Sherkat, "Occupant Behaviour Prediction in Ambient Intelligence Computing Environment", Journal of Uncertain Systems, Volume 2, No.2, pp.85-100, 2008

ATE, 2001: W.Saman, S.M.Vakialtojjar, "Analysis and modeling of a phase change storage system for air conditioning applications", Applied Thermal Engineering 21, page 249-263, 2001

Baillargeon, P., Michaud, N., Toussou, L. and Waide, P., 2011, "Cooling Benchmarking Study: Part 1 Mapping Component Report", available at:

[http://clasponline.org/en/ResourcesTools/Resources/StandardsLabelingResourceLibrary/2012/~/\\_media/Files/SLDocuments/2012/CoolingBenchmarkingStudy/RAC%20benchmarking\\_1%20-](http://clasponline.org/en/ResourcesTools/Resources/StandardsLabelingResourceLibrary/2012/~/_media/Files/SLDocuments/2012/CoolingBenchmarkingStudy/RAC%20benchmarking_1%20-)

---

<sup>28</sup> A multi country initiative to accelerate the improvements in appliance and equipment efficiency under the Clean Energy Ministerial process (see [superefficient.org](http://superefficient.org) for further details).



[%20Mapping%20component.pdf](#)

Bass et al., 2001: B.Bass, B.Baskaran, “Evaluating rooftop and vertical gardens as an adaptation strategy for urban areas”, National Research Council Canada, April 2001, [http://www.roofmeadow.com/technical/publications/BBass\\_GreenRoofs\\_2001.pdf](http://www.roofmeadow.com/technical/publications/BBass_GreenRoofs_2001.pdf), Accessed on 10<sup>th</sup> February 2011

Borgese, A.P., 2008: “Being Green: Green Roofs Offer a Healthier Option”, AIA, LEED AP, August 2008.

Bulut et al., 2011: H.Bulut, M.A.Aktacir, “Determination of free cooling potential: A case study for Istanbul, Turkey”, Applied Energy, Issue 88, pp 680-689, 2011

Cory, W.T.W., 1992: Short History of Mechanical Fans and the Measurement of their Noise. CETIM Publication "FAN NOISE Bruit des Ventilateurs", International INCE Symposium, Senlis, France.

Cremaschi, 2007, HPC, 2007, Heat pump Center, Newsletter n°3, 2007

Daikin, 2007, HPC, 2007, Heat pump Center, Newsletter n°3, 2007.

DGXVII, 1999: J. Adnot, “Energy Efficiency of Room Air-Conditioners (EERAC)”, Directorate General for Energy (DGXVII) of the European Communities, p. 60, 1999

DOE, 2011: “Using the Experience Curve Approach for Appliance Price Forecasting”, United States Department of Energy, February 2011. Available at:

[http://www1.eere.energy.gov/buildings/appliance\\_standards/pdfs/experience\\_curve\\_appliance\\_price\\_forecasting\\_3-16-11.pdf](http://www1.eere.energy.gov/buildings/appliance_standards/pdfs/experience_curve_appliance_price_forecasting_3-16-11.pdf)

Dubin, J.A., Miedema, A.K., Chandran, R.V., 1986. Price effects of energy-efficient technologies—a study of residential demand for heating and cooling. Rand Journal of Economics 17(3), 310–325.

ECCJ, 2006, Final Summary Report by Air Conditioner Evaluation Standard Subcommittee, Energy Efficiency Standards Subcommittee of the Advisory Committee for Natural Resources and Energy; TAKANORI SAITO et al]

EDR, 2011: “Technology Overview: Economizers”, Energy Design Resources, <http://www.energydesignresources.com/resources/publications/technology-overviews/technology-overview-economizers.aspx>, Accessed on 10<sup>th</sup> February 2011.

EuP, 2009: “Preparatory study on the environmental performance of residential room conditioning appliances (airconditioning and ventilation)”, Tasks 1-8, ARMINES, Université de Liège, University of Porto, Austrian Energy Agency, BRE, IASA, December 2008

Greening, L.A., Greene, D.L., Difiglio, C., 2000. Energy efficiency and consumption- the rebound effect—a survey. Energy Policy 28(6–7), 389–401.

Hausman, J.A., 1979. Individual discount rates and the purchase and utilization of energy-using durables. Bell Journal of Economics 10 (1), 33–54.

HETAC, 2011: “High Efficiency Thermal Air Conditioning”, PCP Australia, <http://www.pcpaustralia.com.au/hetac.html>, Accessed on 10<sup>th</sup> February 2011.

IE, 2011: “Ice bear energy storage system”, Ice Energy®, <http://www.ice-energy.com/ice-bear-energy-storage-system>. accessed on 11th February 2011.

IEA 4E M&B, 2010 “4E Mapping Document- Airconditioners”, available at:

[http://mappingandbenchmarking.iea-4e.org/shared\\_files/114/download](http://mappingandbenchmarking.iea-4e.org/shared_files/114/download)

Ismail et al., 1997: K.A.R. Ismail, J.N.C. Castro, “PCM thermal insulation in buildings”, *International Journal of Energy Research* 21 (14) (1997) 1281–1296.

J. Adnot. 1999. Energy Efficiency of Room AirConditioners (EERAC). Directorate General for Energy (DGXVII) of the European Communities, p. 60.

Jakobsen, 2006, Djakobsen, Skiple, Neksa, Wachenfeldt, Stene & Skaugen, Norway, Development of reversible residential air conditioners and heat pumps using CO<sub>2</sub> as working fluid, IEA Heat Pump Center Newsletter, Volume 24 – No. 3/2006.

JFS, 2007: “New Air Conditioners with Infrared Sensors Reduce Energy Use by up to 50%”, <http://www.japanfs.org/en/pages/026571.html>, Accessed on 9<sup>th</sup> February 2011.

JFS, 2009: “Mitsubishi Selling 'Smart' Air Conditioners that Display CO<sub>2</sub> Emissions and Electricity Cost Savings”, <http://www.japanfs.org/en/pages/028702.html>, Accessed on 11<sup>th</sup> February 2011

JRAIA, the Japan Refrigeration and Air Conditioning Industry Association, [http://www.jraia.or.jp/frameset\\_english.html](http://www.jraia.or.jp/frameset_english.html)

Karunakaran et al., 2010: R. Karunakaran, S. Iniyar, R. Goic, “Energy efficient fuzzy based combined variable refrigerant volume and variable air volume air conditioning system for buildings”, *Applied Energy* 2010, volume 87, issue 4, page 1158–75

Koomey et al. 2010 “Defining a standard metric for electricity savings”, *Environ. Res. Lett.* 5: 014017, 2010, doi:[10.1088/1748-9326/5/1/014017](https://doi.org/10.1088/1748-9326/5/1/014017)

Letschert, V., Nicholas Bojda, Jing Ke and Michael A. McNeil, “Estimate of Cost-Effective Potential for Minimum Efficiency Performance Standards in 14 Major World Economies: Energy Savings, Environmental and Financial Impacts”, Lawrence Berkeley National Laboratory. June 2012.

McNeil, M.A., V.E. Letschert, S.A. de la Rue du Can and J. Ke. 2013 “Bottom-Up Energy Analysis System (BUENAS) – An International Appliance Efficiency Policy Tool”. *Energy Efficiency* (2013). Published online January, 2013

McNeil, M. A., V. E. Letschert, and S. de la Rue du Can. 2008. “Global Potential of Energy Efficiency Standards and Labeling Programs.” Lawrence Berkeley National Laboratory. November. <http://ies.lbl.gov/iespubs/LBNL-760E.pdf>

Memon et al., 2008: R.A.Memon, D.Y.C.Leung, L.Chunho, “A review on the generation, determination and mitigation of Urban Heat Island”, *Journal of Environmental Sciences* 20, pp120-128, 2008

Milne, G., Boardman, B., 2000. Making cold homes warmer: the effect of energy efficiency improvements in low-income homes. *Energy Policy* 28, 411–424.

Mimakim M. 1987. “Effectiveness of Finned Tube Heat Exchanger Coated Hydrophilic Type Film”, ASHRAE Transactions, 93(1): pp. 6271.

Nagano et al. 2006: K. Nagano, S. Takeda, T. Mochida, K. Shimakura, T. Nakamura, “Study of a floor supply air conditioning system using granular phase change material to augment building mass thermal storage-heat response in small scale experiments”, *Energy and Buildings* 38 (5) (2006) 436–446.

NAHB, 2011: “Phase Changing Materials”, NAHB Research Centre, <http://www.toolbase.org/TechInventory/TechDetails.aspx?ContentDetailID=775>, Accessed on 10<sup>th</sup> February 2011

NCI, 2011, “Research and Development Roadmap for Next Generation Low-GWP Refrigerants”.

NCE, 2010: “Literature Review of International Studies on Urban Heat Island Countermeasures, Navigant Consulting Europe, 17<sup>th</sup> November 2010

NREL, 2011: E.Kozubal, J.Woods, J.Burch, A.Boranian, T.Merrigan, “Desiccant Enhanced Evaporative Air-Conditioning (DEVap): Evaluation of a New Concept in Ultra Efficient Air Conditioning”, NREL Technical Report-5500-49722, January 2011, <http://www.nrel.gov/docs/fy11osti/49722.pdf>

Ortiz, 2003, Thomas M. Ortiz, Daqing Li and Eckhard A. Groll, “Evaluation of the performance potential of CO<sub>2</sub> as a refrigerant in air-to-air air conditioners and heat pumps: System modeling and analysis, ARTI-21CR/610-10030

Parameshwaran et al., 2010: E&B, 2010: R. Parameshwaran, S. Harikrishnan, S. Kalaiselvam, “Energy efficient PCM-based variable air volume air conditioning system for modern buildings”, *Energy and Buildings* issue 42, pp1353-1360, 2010

Pham H., and Sachs, H., 2010, “Next Generation Refrigerants: Standards and Climate Policy Implications of Engineering Constraints”, 2010 ACEEE Summer Study on Energy Efficiency in Buildings. Available at:

<http://www.aceee.org/files/proceedings/2010/data/papers/1933.pdf>

Rajendran, R. 2011, “Refrigerants Update” Emerson Climate Technologies, September 19, 2011. Available at:

<http://www.emersonclimate.com/Documents/Refrigeration/Refrigerants%20Update.pdf>

Riviere et al., 2008/2009: Preparatory Study on the Environmental Performance of Residential Room Conditioning Appliances (airconditioning and ventilation). Tasks 1-8.

Roy, J., 2000. The rebound effect: some empirical evidence from India. *Energy Policy* 28 (6–7), 433–438.

Sorrell, S. D. (2009). Empirical Estimates of the Direct Rebound Effect : A Review. *Energy Policy* .

SST, 2011: Green AC Case Studies: About AMAX®Speakman®, Accessed 9<sup>th</sup> February 2011, [http://solarshieldtechnologies.com/About\\_AMAX\\_Speakman.html](http://solarshieldtechnologies.com/About_AMAX_Speakman.html)

Stetiu et al., 1998: C. Stetiu, H.E. Feustel, “Phase-change Wallboard and Mechanical Night Ventilation in Commercial Buildings”, Lawrence Berkeley National Laboratory, University of California, 1998,

<http://epb.lbl.gov/thermal/docs/pcm2.pdf>, Accessed on 10<sup>th</sup> February 2011

THA, 2011: “Central Air Conditioner Diagram: Thiele Heating & Air Conditioning”, <http://www.callthiele.com/images/installation.gif>, accessed on 6<sup>th</sup> February 2011

TSD, 2010a: Residential Central Air Conditioners and Heat Pumps, Technical Support Document

[http://www1.eere.energy.gov/buildings/appliance\\_standards/residential/cac\\_heatpumps\\_new\\_rulemaking.html](http://www1.eere.energy.gov/buildings/appliance_standards/residential/cac_heatpumps_new_rulemaking.html), Accessed on 17<sup>th</sup> February 2011

TSD, 2010b: “Technical Support Document: Energy Efficiency Program For Consumer Products and Commercial and Industrial Equipment: Residential Clothes Dryers and Room Air Conditioners”, Navigant Consulting Inc. And Lawrence Berkeley National Laboratory, February 2010

Turnpenny et al., 2001: J.R.Turnpenny, D.W. Etheridge, D.A.Reay, “Novel ventilation system for reducing air conditioning in buildings, Part II: testing of prototype”, Applied Thermal Engineering 21, pp1203-1217, 2001

Waide, P., Riviere, P., and Watson, R., 2011, “Cooling Benchmarking Study: Part 2 Benchmarking Component Report”,

[http://clasponline.org/en/ResourcesTools/Resources/StandardsLabelingResourceLibrary/2012/~/\\_media/Files/SLDocuments/2012/CoolingBenchmarkingStudy/RAC%20benchmarking\\_2%20-%20Benchmarking%20component.pdf](http://clasponline.org/en/ResourcesTools/Resources/StandardsLabelingResourceLibrary/2012/~/_media/Files/SLDocuments/2012/CoolingBenchmarkingStudy/RAC%20benchmarking_2%20-%20Benchmarking%20component.pdf)

Wang et al., 2005: “Experimental study on split air conditioner with new hybrid equipment of energy storage and water heater all year round”, Energy Conservation and Management 46, pp3047-3059, 2005

World Bank, 1999: G.J.Bom, R.Foster, E.Dijkstra, M.Tummers, Evaporative Air-Conditioning – Applications for Environmentally Friendly Cooling, World Bank Technical Paper No.421, Energy Series, March 1999

Zhang et al., 2005: M. Zhang, M.A. Medina, J.B. King, “Development of a thermally enhanced frame wall with phase-change materials for on-peak air conditioning demand reduction and energy savings in residential buildings”, International Journal of Energy Research 29 (9) (2005) 795–809.

## Appendix A: Climate Specific Efficiency Improvement Options

In this appendix we present and discuss Room AC technologies and efficiency improvement options that are climate-specific and could further improve efficiency beyond the levels discussed in chapters 3 and 4.

### Evaporative Cooling

Evaporative air conditioning or EAC technologies are becoming increasingly popular in residential as well as commercial applications in countries with hot, dry climates.

EAC systems use water as the coolant as opposed to chemical refrigerants. EAC can provide superior ventilation and cooling over the traditional vapor compression air conditioning (VAC). However, unlike VAC systems which are capable of operating under a wide variety of climatic settings, EAC varies in effectiveness and efficiency with the relative humidity of the outside air. EACs have the added benefits that they reduce the requirement for traditional fluid refrigerants, avert CO<sub>2</sub> emissions and reduce the peak electricity demand.

The Optimal operation for EACs is in hot, dry climates although they are applicable in more humid climates. EACs are widely used in the South Western US, Middle East, Australia, the Indian subcontinent, Eastern Africa and northern Mexico<sup>29</sup>.

Evaporative coolers can use up to 75% less electricity than conventional air conditioning which can equate to \$150 a year savings on electricity bills, this invariably depends on the climate of the building, for hotter desert like climates savings could be even higher (source:<sup>30</sup>) These systems do not use CFCs or any other ozone harming compounds and cost less to operate than conventional air conditioners including the initial cost of the unit and the installation costs. Another benefit of evaporative coolers is that they do not re-circulate 'old' air like other systems, rather they facilitate a complete air change every 1-3 minutes (source:<sup>31</sup>).

Drawbacks to the system include the high consumption of water, between 3.5 and 10.5 gallons per hour of operation**Error! Bookmark not defined.**; regular maintenance, units are often noisy; units can drip water and leak; less energy efficient than high efficiency AC systems; and the units are less effective in high humidity climates and should only really be used in hot dry climates<sup>32</sup>.

The Table A-1 below shows the performance of a typical evaporative cooler on room air conditioner according to humidity and outside temperature. The optimum room temperature is around 68-72 degrees Fahrenheit, but depends on the country and personal preference. In order to achieve this temperature conditions must be right. High temperatures can have a serious impact on the effectiveness of the unit, over

---

<sup>29</sup> <http://www.coolmax.com.au/evaporative-cooling/evaporative-cooling-areas.htm> accessed 05/04/2011

<sup>30</sup> [http://www.consumerenergycenter.org/home/heating\\_cooling/evaporative.html](http://www.consumerenergycenter.org/home/heating_cooling/evaporative.html) accessed 04/04/2011

<sup>31</sup> <http://www.toolbase.org/Technology-Inventory/HVAC/evaporative-coolers> accessed 05/04/2011

<sup>32</sup> <http://www.azcentral.com/business/articles/2010/10/10/20101010biz-evaporative-coolers-disappearing-from-Phoenix-area-homes-1001.html> accessed 05/04/2011

100 degrees Fahrenheit and humidity levels must be very low, 2-10% for the unit to work effectively, the same can be stated for very high humidity levels which must be coupled with low temperatures in order to provide optimum conditions for the unit.

**Table A-1 Cooling Performance of Evaporative Cooler on Room Air Temperature**

Outdoor Air Temperature	% Relative Humidity																
	2	5	10	15	20	25	30	35	40	45	50	55	60	65	70	75	80
75	54	55	57	58	59	61	62	63	64	65	66	67	68	69	70	71	72
80	57	58	60	62	63	64	66	67	68	69	71	72	73	74	76	76	77
85	61	62	63	65	67	68	70	71	72	73	74	75	76	77	79	81	
90	64	65	67	69	70	72	74	76	77	78	79	81	82	83	84	86	
95	67	68	70	72	74	76	78	79	81	82	84	85	87				
100	69	71	73	76	78	80	82	83	85	87	88						
105	72	74	77	79	81	84	86	88	89								
110	75	77	80	83	85	87	90	92									
115	78	80	83	86	89	91	94										
120	81	83	86	90	93	95											
125	83	86	90	93	96												

Source: Ed Phillips, Arizona Almanac

**Direct residential air conditioners**

A residential EAC system normally comprises a sheet metal or plastic box which contains large vertical filter pads; a fan connected to an electric motor; a water pump; and an associated water distribution system. A schematic representation of the arrangement of this configuration is illustrated in Figure A-1.

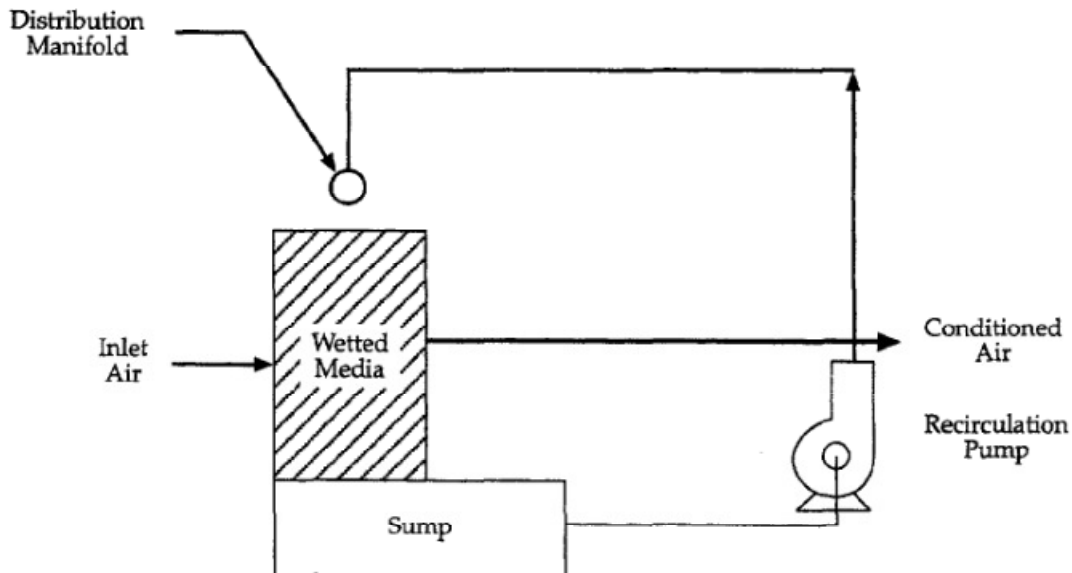

**Figure A-1: Typical direct evaporative air conditioner**

Source: World Bank, 1999

As illustrated in the diagram, the fan draws in the warm air from outside the building through the wetted pad area, thus cooling the air. The role of the water pump is to draw water from the sump and deposit it through the distribution system onto the top of the pads. This simple low cost solution of direct EAC is suitable for indoor comfort cooling once the ambient wet-bulb temperatures reach 21°C (69.8°F). Direct EAC systems operating in regions of low humidity are capable of yielding energy savings in the range of 60-80% over VAC systems (World Bank, 1999).

### Indirect evaporative air conditioning

The indirect-direct EAC was developed over the past 25 years and has grown in popularity due to its ability to provide improved cooling and operating conditions over the direct EAC method. In essence an additional step is introduced into the cooling process making it a two stage process.

The first stage seeks to cool the air without the addition of moisture to the air and the second stage adds the moisture. Typically, the air expelled by the Indirect EAC unit is 3.5°C (6.30°F) cooler than the simple direct EAC system. This expands the applicability of the EAC to climates with higher wet-bulb temperatures. Indirect-direct EAC systems are thought to yield between 40-50% energy savings in moderate humidity climates over traditional VAC systems (World Bank, 1999). A diagrammatic representation of the indirect-direct EAC process is presented in Figure A-2.

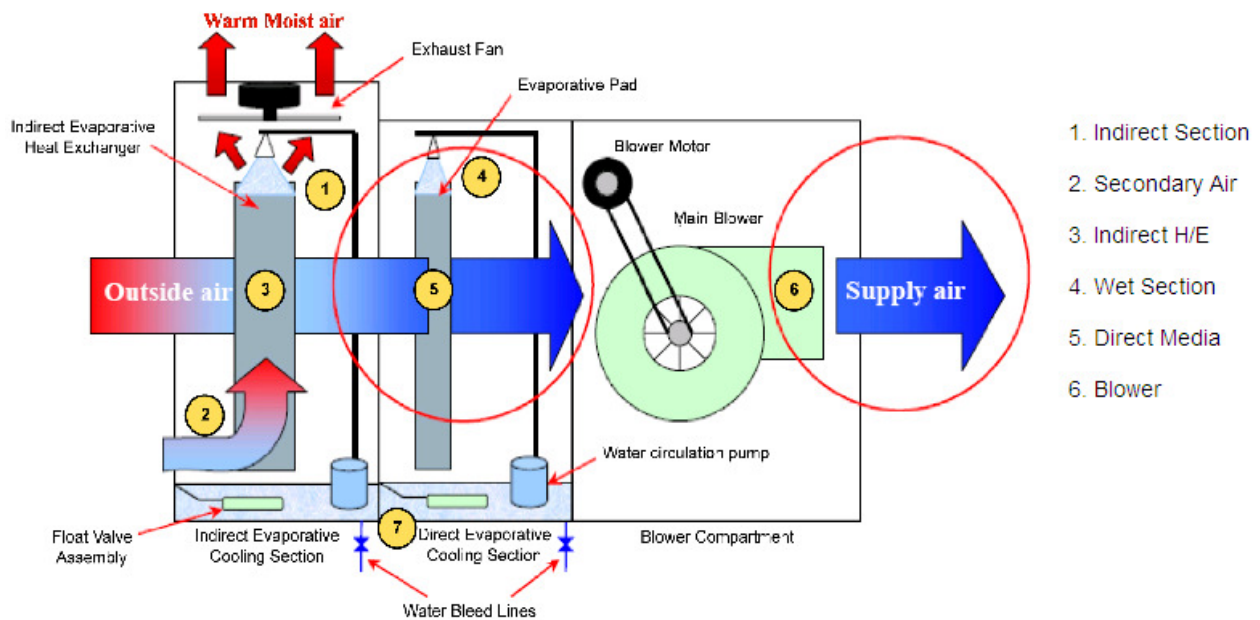

Figure A-2: Indirect-direct evaporative air-conditioning process

Source: SST, 2011

### Desiccant-assisted evaporative air-conditioning

There have also been significant developments to adapt the EAC technology to even the most humid of



regions by using dehumidifying chemicals such as desiccants (e.g. silica gel). The desiccant is employed by dehumidifying the ventilation air to a set-point followed by passing the resulting air through either a direct or indirect EAC system which then cools the ensuing air to the desired temperature. The air cycle for the desiccant cooling system is illustrated in Figure A-3 below.

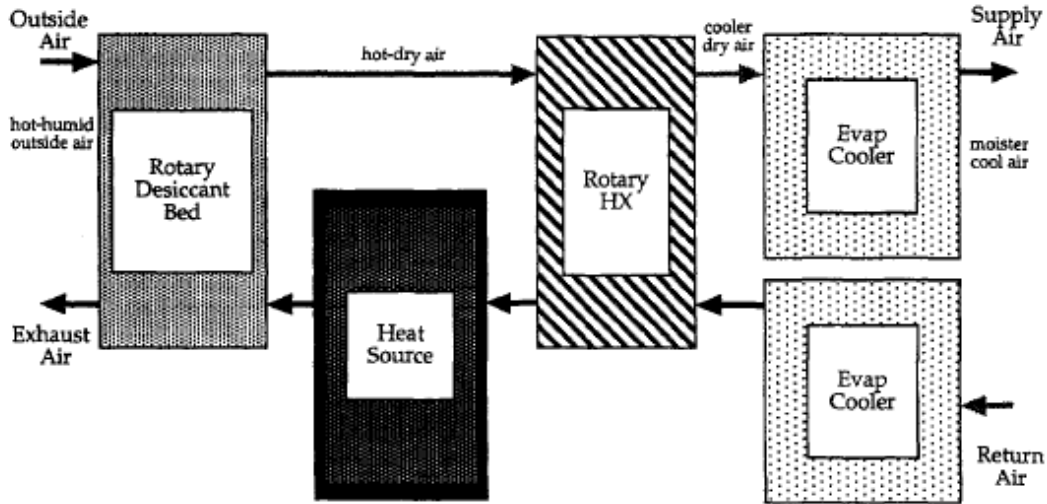

Figure A-3: Air cycle for the desiccant cooling system

Source: World Bank, 1999

### Desiccant-Enhanced Evaporative Air Conditioning (DEVap) (NREL, 2011)

The National Renewable Energy Laboratory (NREL) has recently developed a novel concept of combining the benefits of using liquid desiccants and the evaporative cooling technologies. This has enabled the scope of the stand-alone indirect evaporative coolers to extend their geographical applicability beyond the arid or semiarid regions. Earlier attempts to combine liquid desiccant cooling with indirect evaporative cooling resulted in oversized, overcomplicated equipment, whereas NREL's DEVap combines evaporative and desiccant cooling into one single cooling core unit.

DEVap's central advantage is gained by the intimate thermal contact between the cooling heat sink and dehumidification, which results in more potent dehumidification potential. This results in unique optimization benefits which include using cheaper desiccant materials as well as a more compact cooling core. DEVap uses membrane technology to contain the liquid desiccant and water. When used to contain liquid desiccant, it eliminates desiccant entrainment into the air-stream. When used to contain water, it eliminates wet surfaces, prevents bacterial growth and mineral build-up, and avoids any cooling degradation of the core. **Error! Reference source not found.** below illustrates (a) the physical DEVap concept; (b) high-level illustration of the DEVap air conditioning unit.



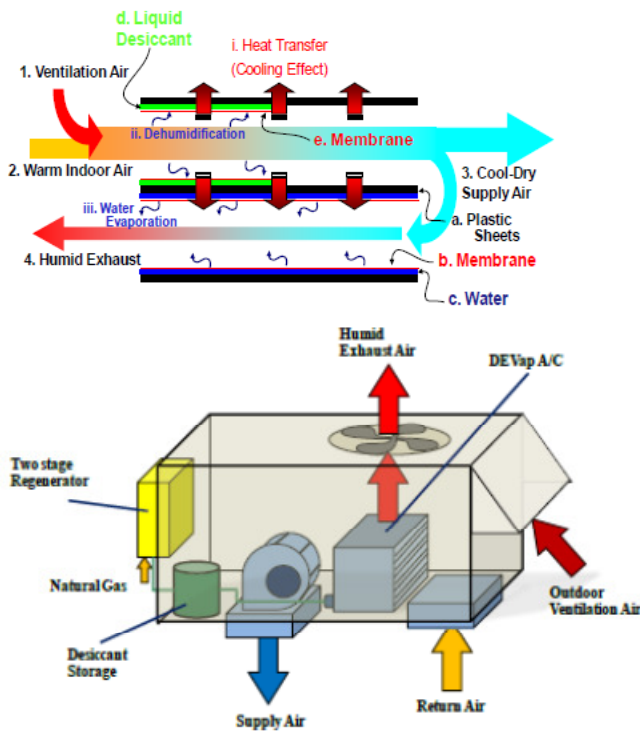

Figure A-4: (a) Physical DEVap concept; (b) Illustration of DEVap air conditioning unit

Source: NREL, 2011

DEVap’s thermodynamic potential prevails over some of the shortfalls which face standard refrigeration-based direct expansion cooling. In essence, DEVap decouples cooling and dehumidification performance resulting in independent control of temperature and humidity.

Modeling conducted by NREL has demonstrated that the yearly combined source energy for the thermal and electrical energy required to operate DEVap is anticipated to be 30%–90% less than state-of-the-art direct expansion cooling (naturally dependent on whether it is applied in a humid or a dry climate). Moreover, NREL indicates that desiccant technology is a new science with unpracticed technology improvements that can reduce energy consumption by an additional 50% (NREL, 2011).

### Solar evaporative air-cooling

Given that EACs require a relatively low energy requirement combined with the fact that strong sunlight often coincides with the requirement for cooling, there is a natural marriage between EAC systems and solar PV systems. Naturally there is an optimization of the EAC system components to maximize the efficiency of the system to enable it to function on solar power. Moreover, it is important to note that most of the investment cost would go into buying the solar panels. A simple diagram of the solar powered EAC system is provided in Figure A-5.

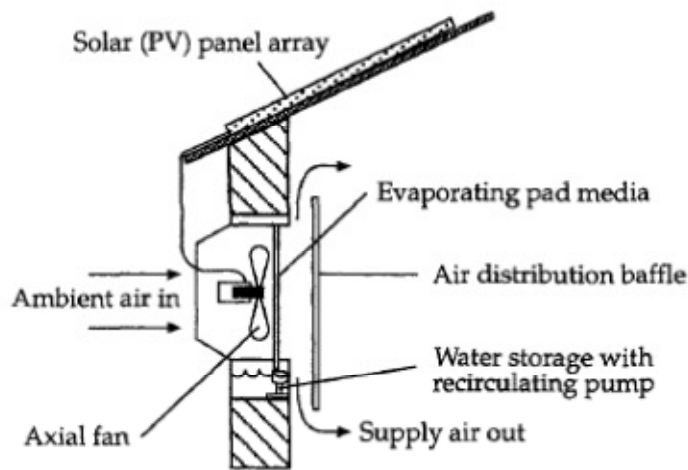

Figure A-5: Solar powered evaporative air conditioner

Source: World Bank, 1999

### Phase Change Materials

Thermal energy storage is a relatively new technological area with applicability to a wide range of thermal and cooling applications. Phase change materials or PCM, are materials which can store and release thermal energy during the processes of melting and freezing. Such materials can release large quantities of energy during freezing in the form of latent heat but absorb equal amounts of energy from the surrounding environment upon melting. PCMs have several added benefits over traditional thermal energy storage systems in which they potentially have less weight and volume, can absorb and release heat/cooling at suitable and pre-determined temperatures and in well designed air conditioning systems shift peak heating and cooling loads to off peak hours (ATE, 2001). PCM materials are already actively used to support air conditioners, free cooling, passive cooling, solar heating, transport packaging and heat recovery.

PCM are being developed in several forms most commonly now in enclosure-based systems to supplement more conventional cooling/heating systems typically in the form of air conditioners.

PCMs are selected such that they are solid at room temperature. When the temperature increases, the PCMs change state, from solid to liquid and absorb a large amount of energy from the surrounding atmosphere in the form of latent heat; this therefore has a cooling effect on the room. Equally, when the temperature begins to fall, the material will undergo another change of state and solidify thus giving off the excess energy in the form of heat which in turn warms the house. The integration of PCMs within the building envelope ensures that the PCM absorbs the higher exterior temperature during the day, and dissipates the heat to the interior at night when it is cooler and often required.

A number of properties which are desirable for PCMs which are to be used in a residential environment include but are not limited to: a melting temperature above 25°C (77°F); low material cost; non toxic, corrosive, or hygroscopic; and available in plentiful quantities for inclusion into building materials (NAHB, 2011).

There are a variety of different methods to incorporate PCMs into building materials and HVAC systems in

order to achieve energy savings. These methods include: incorporation in roofs; walls; floor boards; surrounding of piping; wall boards; and PCM encapsulated in storage tanks (Parameshwaran et al., 2010).

Figure A-6 below provides a simple illustration of one of the methods used to integrate PCMs in conjunction with a conventional air conditioner system and a standard air/water heat exchanger.

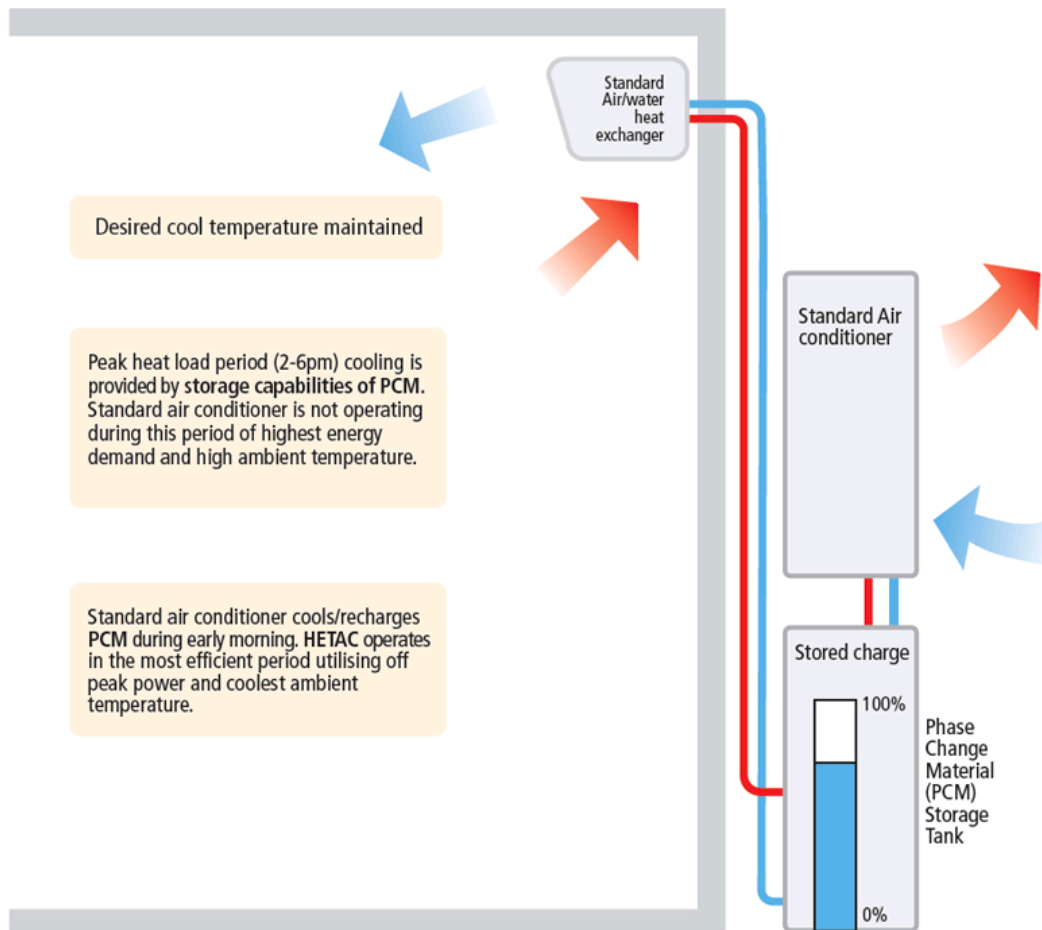

**Figure A-6: PCM storage tank integrated with an air conditioner unit and air/water heat exchanger**

Source: HETAC, 2011

A number of different studies have used simulation and experimentation to quantify the benefits of using PCMs of which a selection is summarized in the table below:

**Table A-1: Summary of main outcomes from PCM Simulations & Experimentation**

PCM used	Integration of PCM	Study objective	Key results	Evaluative Technique	Reference
A mixture of commercial Glycol wax	Integrated into roof and building walls	Evaluation of the effects of retrofitting on a building in Brazil	Saving 19% and 31% of energy for cases using window and central a/c units	Simulation and experimentation	Ismail et al., 1997
Highly crystalline paraffin-based PCM	PCM frame walls	Full instrumented test house of 1.83mx1.83mx1.22m in Lawrence, KS, USA	Space cooling load and average wall peak heat flux reduced approximately 8.6% and 15% respectively	Experimentation	Zhang et al., 2005
PCM composed of foamed glass beads and paraffin waxes	PCM embedded directly below OA floor boards in the form of granules	A simple experimental rig system with floor area of 0.5m <sup>2</sup> was evaluated	89% daily cooling load can be stored at night using a 30mm bed of granular PCM	Experimentation	Nagano et al. 2006
Paraffin-based PCM	Phase change wallboard containing 20% by paraffin mass	A prototype IEA building located in California climate condition was selected	29% of the peak cooling load was expected to be reduced	Simulation	Stetiu et al., 1998

Source: Parameshwaran et al., 2010

As indicated by **Error! Reference source not found.** and other research in the field, a number of different materials which meet most of the PCM specifications have been identified. For example, paraffin compounds (linear crystalline alkyl hydrocarbons) are now commercially available from petroleum refining or polymerization. Moreover, some of the manufacturers have demonstrated processes that successfully incorporate paraffin beads into wallboard, floor boards and roofing materials. It is important to note however, that more research is required before the technology is widely adopted.

### Free Cooling for Window/Louvered Air Conditioners

Window (Europe) or through-the-wall (USA) package air conditioners are typically able to use cold outdoor air (during cooler periods such as nighttime) to free cool when the conditions are appropriate. Such systems use what is known as an economizer cycle, which has existed for several years. Today there are two types of economizers in use, the water-side economizer and the air-side economizer. The air-side economizer takes advantage of the cool outdoor air to either assist mechanical cooling or in the event the outdoor air is cool

enough to provide total cooling. The water-side economizer consists of a water coil situated in the self-contained unit upstream of the direct-expansion cooling coil (Bulut et al., 2011). An economizer illustration is provided in Figure A-7.

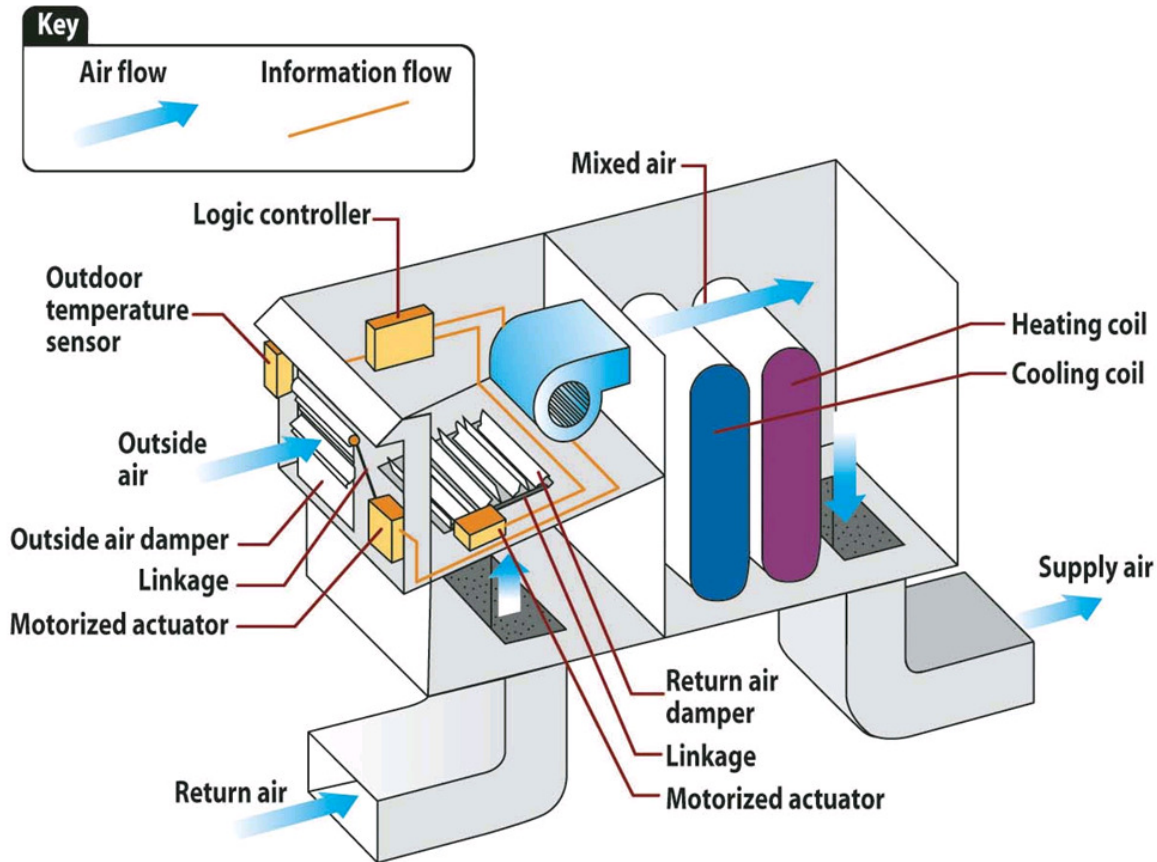

Figure A-7: Diagrammatic Representation of an Economizer

Source: EDR, 2011

Free cooling demonstrates the potential role of ventilation in securing indoor comfort without the need for mechanical cooling systems, although it is important to note that free cooling need not be viewed as an alternative to mechanical cooling. Indeed, it can be used in a complementary and supportive role for conventional air conditioning units with many studies demonstrating that significant energy savings can be achieved with the use of free cooling in different climatic conditions.

This form of “free cooling” option is now also available for larger units for instance on VRV systems although it is uncommon for the primary air introduction to be controlled by the cooling equipment. Single-duct air conditioner devices use this free cooling effect; however, it has the drawback of introducing hot air in the warmer seasons. Split air conditioners capable of using fresh air in order to free cool the inside air can economize compressor power consumption and thereby lower active cooling energy consumption by up to a factor of two (EuP, 2009).

A study conducted by Karunakaran et al. examined the combination of a VRV system and a variable air volume (VAV) air conditioning system controlled by an intelligent fuzzy logic controller under summer and winter climatic conditions in order to quantify the energy savings capabilities. The proposed system experimentally analyzed under fixed ventilation, demand controlled ventilation (DCV) and combined DCV and economizer cycle ventilation techniques, effectively conserved 63% and 44% of the daily average energy savings under winter and summer conditions in comparison with a constant air volume air conditioning system (Karunakaran et al., 2010).

There are, however, certain drawbacks and barriers which need to be weighed up; these include the cost of installation, introduction of outside noise and the need to include air treatment, which may be necessary to prevent air pollution being drawn in from the outside. It is also important to note that the energy saving benefit of a “free-cooling” option is not recorded under standard energy performance test conditions and hence is not reflected in energy efficiency ratings.

Lastly energy efficiency can be increased by optimizing the approach used to maintain the evaporating temperature low enough to provide adequate dehumidification capability. In the US the most common approach is to continuously operate the evaporation cycle at a low enough temperature to provide dehumidification whereas in Japan a two stage approach is common that allows a more efficient (high temperature) sensible cooling cycle to be interspersed with a more occasional lower temperature dehumidification cycle. This is done through the addition of a second, dedicated expansion valve.

### Storage of Cooling at Night

Thermal storage technology is essentially the principle attached to materials which have the capacity to retain heat for a sustained period of time, often in the range of hours to a few days. A critical parameter is the material mass as it is reflective of the materials ability to retain heat – residential construction materials such as masonry exhibit this heat retention property.

Some storage materials are selected and situated so they can store cooling by drawing out the heat from the surrounding residential atmosphere, effectively cooling the spaces they occupy. The basic principle of night storage of cooling is to take advantage of the lower ambient temperatures at nighttime in order to accumulate low grade cooling energy and the cool radiant effect of chilled ceilings. Then the stored energy, referred to as cooling or coolth is gradually released during the daytime through radiation and convection.

There have been a number of novel developments which seek to take advantage of this night storage principle, including:

- The use of phase changing materials (PCM) to store the cooling at a nominally constant temperature and heat pipes to obtain enhanced heat transfer between the PCM and air. Such designs are explored by Turnpenny in 2001 who developed and tested a proto-type system under normal summer conditions in the UK (Turnpenny et al., 2001)
- Development of a unique distributed energy storage system which works in harmony with a conventional air conditioning system. The system stores energy at night by freezing water when the electricity being produced is cleaner, less expensive and more efficient, and releasing the energy by thawing the ice at peak demand points during the day in order to provide cooling for the building and reduce the burden on the conventional air conditioner system (IE, 2011)

There have also been significant developments of split air conditioners fitted with hybrid equipment in the

form of thermal energy storage and water heaters to ensure the device applicability all year round. The specially designed hybrid tank can be attached directly to a split air conditioner. In the summer months the ice storage coils operate as the evaporator where ice storage is conducted during off peak electrical demand periods in fairly cool environments. During times of peak power consumption, when required the storage coils operate as a super cool condenser which has the benefit of improving the COP of the split air conditioner system. During the winter months, the energy storage tank is regarded as a heat store and absorbs the condensing heat to store heat during the heating process. When compared to the original split air conditioner unit, the average cooling capacity of the new hybrid system increases by 28.2%, and the COP increases by 21.5% (Wang et al., 2005). A schematic diagram of this unique hybrid combination of split air conditioner, water heater and energy storage device is provided in Figure A-8 below.

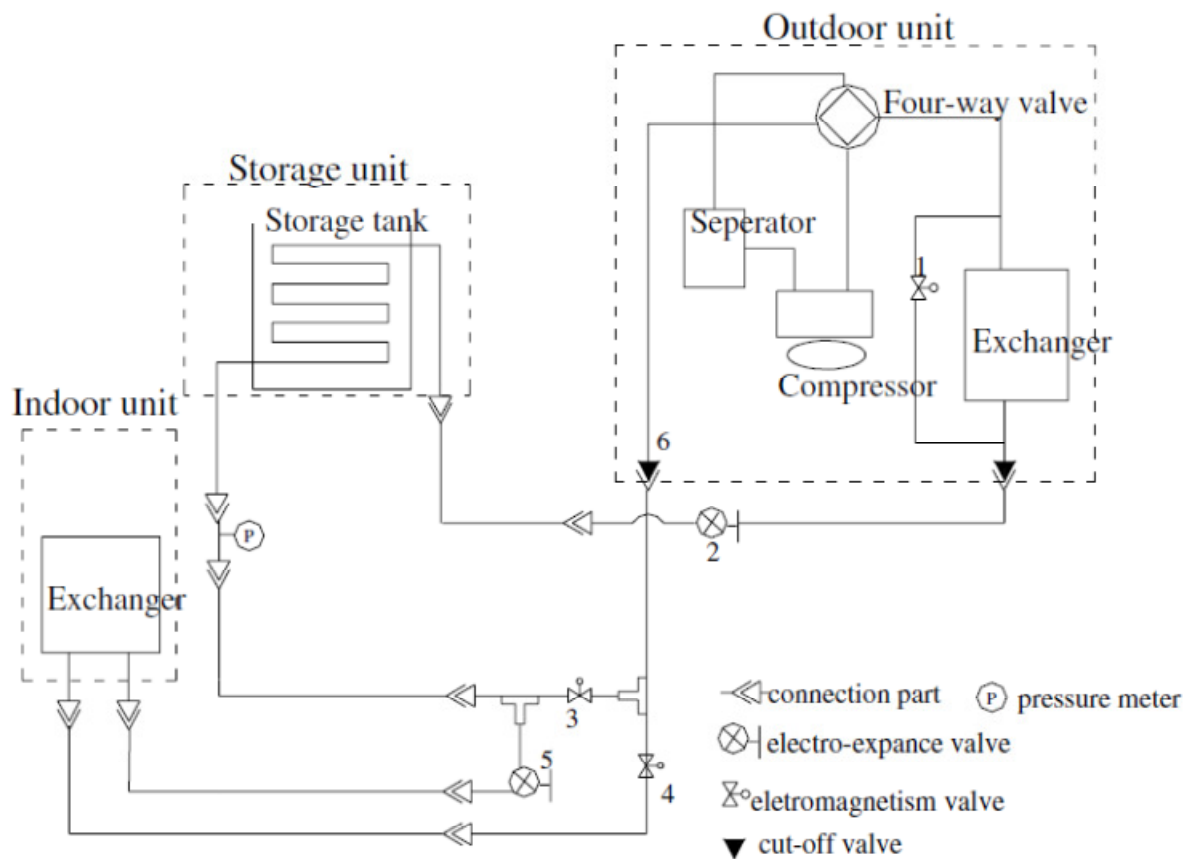

Figure A-8: Schematic diagram of Combined A/C, water heater and energy storage system

Source: Wang et al., 2005

### Radiative cooling – Cool Roofs

Roofing material with low reflectivity values tend to adsorb heat from sunlight rather than reflect it back into space. Roofing material with high emissivity will radiate any stored heat quickly. “Cool roofs” exploit these two phenomena by using combinations of high-reflectivity and high emissivity materials to minimize the



amount of sunlight that is converted to heat in the roof material and maximize the amount of heat that is radiated away from the roof. In principle, buildings with cool roofs will have lower cooling loads and cooling energy demand because they reduce the amount of solar energy entering the conditioned space from the roof and thus reduce cooling loads. For the same reasons, cool roofs tend to increase heating loads during the heating season in non-equatorial climates because less of the sun's energy is converted to heat by the roof and conducted into the conditioned space.

As roofs are either horizontal or angled off horizontally, a significant proportion of the solar radiation reflected from the roof will be directed back to the sky vault. This means that increasing the reflectivity of roofs not only has the potential to lower air conditioning loads (and thereby lower energy use and associated CO<sub>2</sub> emissions), but also has the potential to reduce the amount of solar energy trapped in the troposphere by increasing the reflection of solar radiation back into space.

Studies have shown that reflective roofs are most effective where there is a high roof to volume ratio and that savings are greatest for buildings located in climates with longer cooling seasons and short heating seasons. Furthermore, many of these studies have shown that by raising roof reflectivity from 10-20% to about 60% cooling-energy use in buildings can be reduced in excess of 20% (Memon et al., 2008).

The benefits in equatorial, arid and warm temperate climates have led to incentive programs, product labeling and standards to promote cool roofs.

### Shading with vegetation

Plants, trees, and vegetation increase shading over the surface they occupy, blocking sunlight/heat from that surface. The heat that reaches either the greenery or the ground beneath it can often be dissipated through evapotranspiration – heat in the surrounding air/surfaces is used to evaporate the water. Often such greenery and its cooling effects are exploited in buildings such as “green roofs” on roof tops or strategically designed/naturally occurring “trees and vegetation” around buildings and urban spaces. Thanks to the natural processes of shading and evapotranspiration surfaces such as greens roofs stay cooler than conventional rooftops under summertime conditions. In principle, the use of green roofs will tend to lower the amount of solar energy entering the conditioned space from the roof and thus reduce cooling loads. Similarly, strategically positioned trees and vegetation can also provide shading to both pavements and buildings. This results in less of the sun's energy being absorbed by the shaded surface, hence reducing the solar energy entering into the conditioned space which reduces cooling loads as well as keeps the pavements cool which lowers the ambient temperature (indirectly reducing air conditioning load).

For the same reasons green roofs tend to increase heating loads during the heating season in non-equatorial climates because less of the sun's energy is converted to heat in the roof and conducted into the conditioned space, during the winter season deciduous trees have no leaves meaning they provide less shading. Furthermore, trees can often offer other benefits during the winter such as shielding urban buildings/structures from cold winter winds. Nonetheless, as there is less solar energy in the winter than the summer, the quantity of solar energy converted to heat within the roof is greater in the summer than the winter, thus shading and evapotranspiration displaces more summer heat gain than winter heat gain.

Research shows that green roofs offered a greater cooling per unit area than light surfaces but less cooling per unit area than curb-side planting. Data gathering, modeling and simulation allowed examination of trees and vegetation on individual buildings and cities. Urban trees were found to provide evapotranspiration, shading and wind protection to buildings and pavements resulting in energy, peak power and CO<sub>2</sub> savings (NCE, 2010).



In a study of green roofs the roof temperature of a standard flat roof was measured at 90°F and compared to a 60°F temperature which was recorded below the vegetation on an adjacent area of green roof. In previous studies it was observed that a 3-7°F drop in temperature could reduce air conditioning loads by 10%, so taking this into consideration, if a green roof was installed on a one story building it could reduce air conditioning costs by up to 30% (Borgese, 2008).

A Canadian study using a Visual DOE model to evaluate the heating and cooling energy savings for a one-story office building with a 3,000m<sup>2</sup> green roof in the city of Toronto Canada revealed that the shading and insulation of the green roof garden reduced the heating energy by 10% and cooling by 6% with an overall total energy usage reduction of 5%. The low cooling reduction was attributed to increased insulation due to the green roofs' reduced dissipation rate of internally generated heat; and the existing building insulation that reduced the heat flow into the building in summertime and reduced the heat flow out in wintertime. The same simulation was run in Santa Barbara, California, where it became evident that with lower amounts of insulation the cooling savings were increased to 10% (Bass et al., 2001).

It is, however, generally accepted that the use of urban trees and vegetation could face heat penalties in cold climates but reduce energy in hot climates.

## Appendix B. AC Manufacturing Cost Curves for Various Economies

In this appendix we present the manufacturing costs for various efficiency levels in each of the economies studied. These can be used as initial starting point estimates to design rebate or upstream manufacturer incentive programs in each of these economies, with manufacturer incentives set at the incremental cost of efficiency improvement or a fraction thereof.

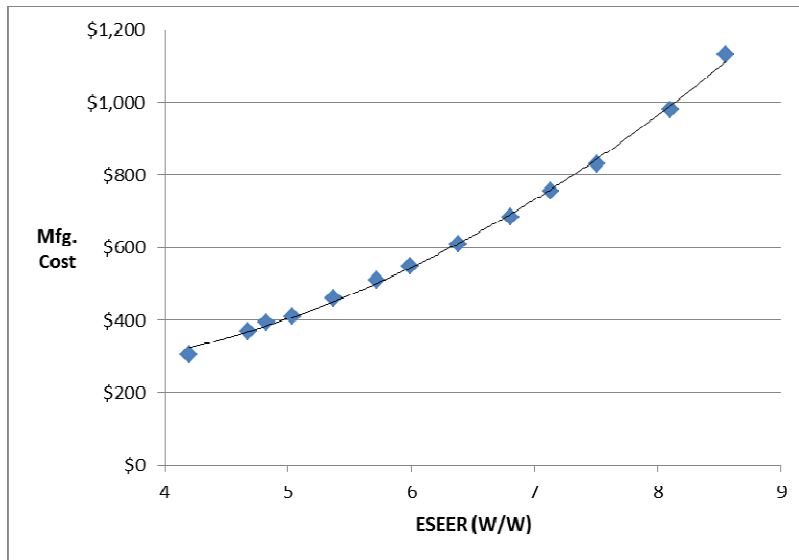

Figure B-1: Manufacturing Cost vs ESEER for Australia

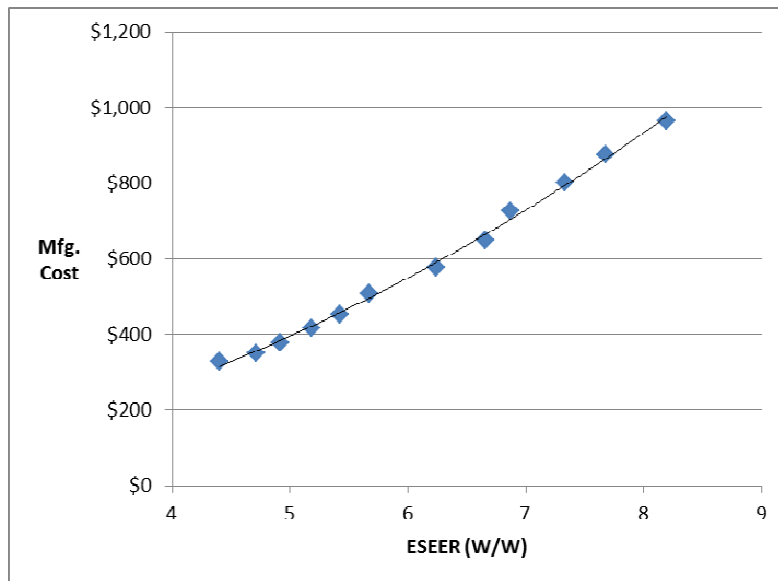

Figure B-2: Manufacturing Cost vs ESEER for Brazil

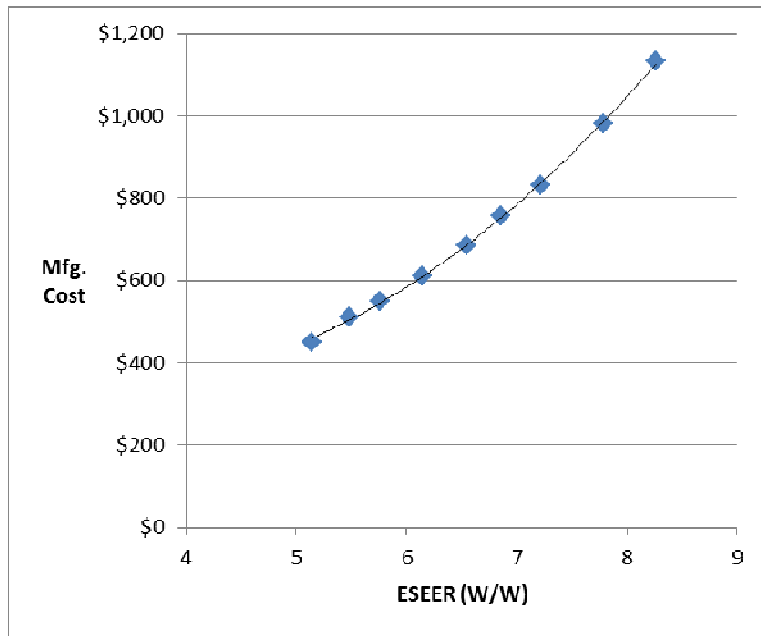

Figure B-3: Manufacturing Cost vs ESEER for Canada

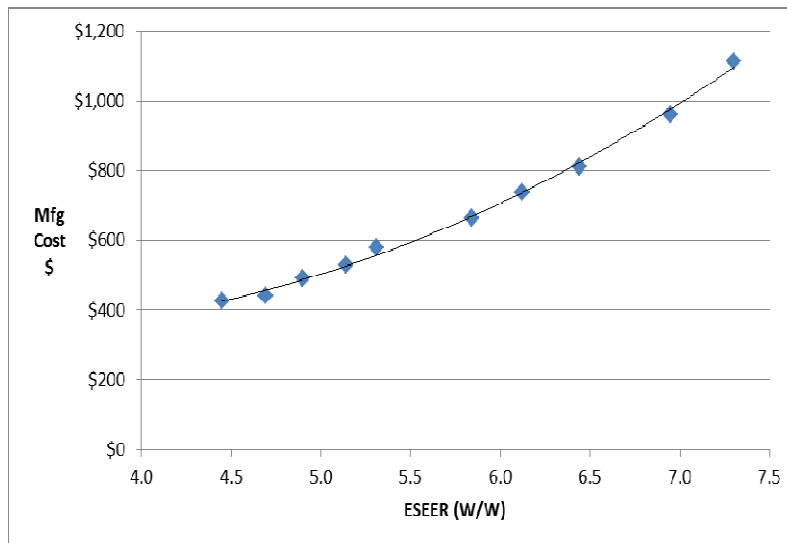

Figure B-4: Manufacturing Cost vs ESEER for China

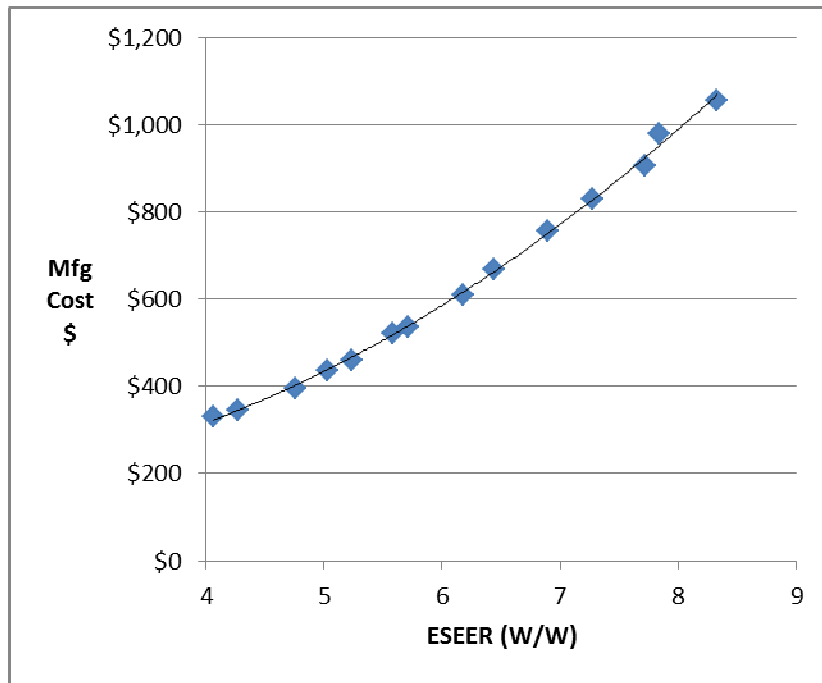

Figure B-5: Manufacturing Cost vs ESEER for the EU

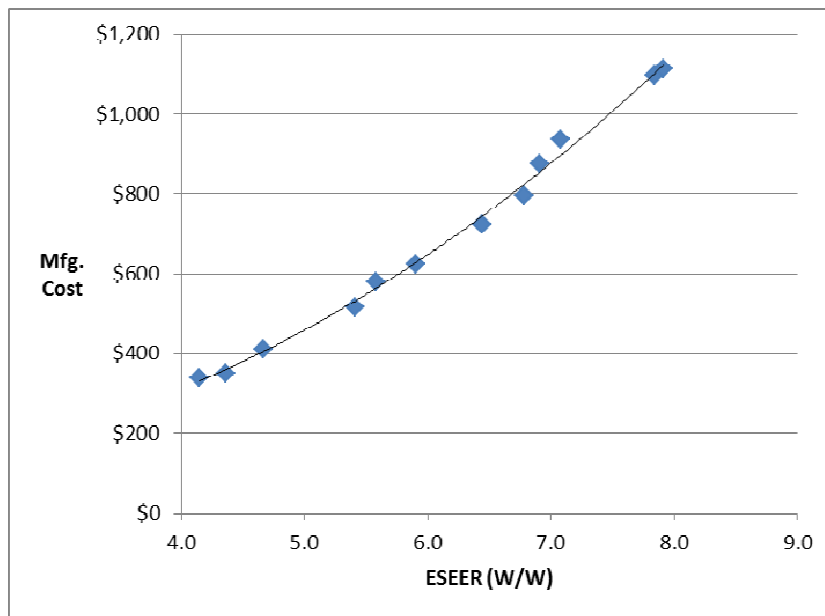

Figure B-6: Manufacturing Cost vs ESEER for India

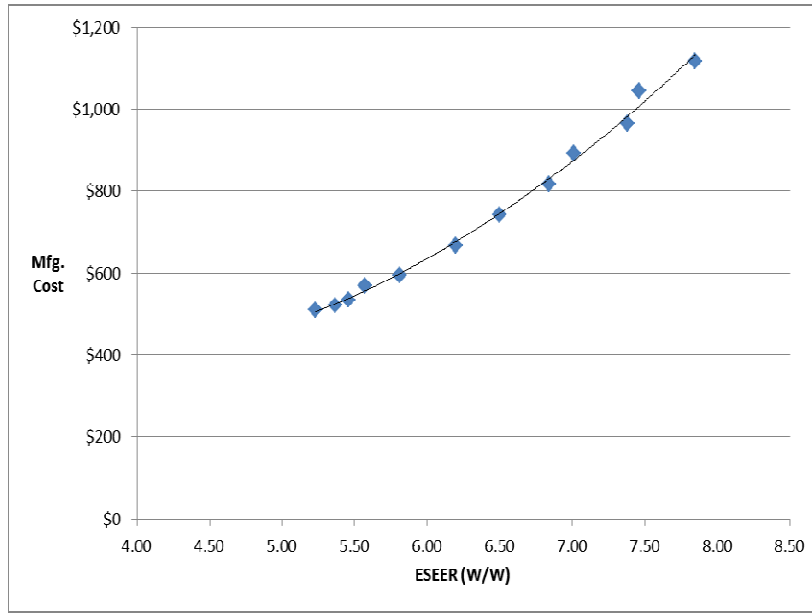

Figure B-7: Manufacturing Cost vs ESEER for Japan

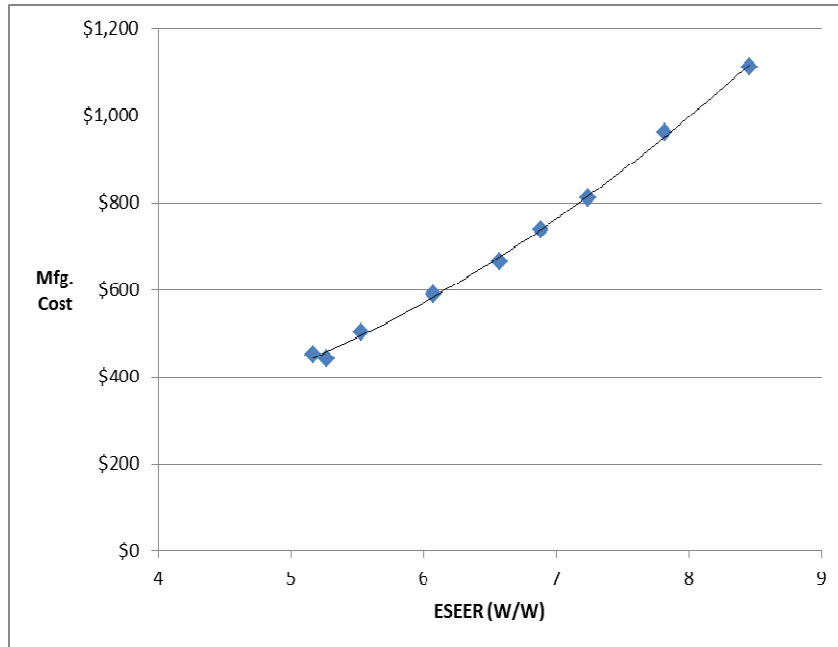

Figure B-8: Manufacturing Cost vs ESEER for Korea

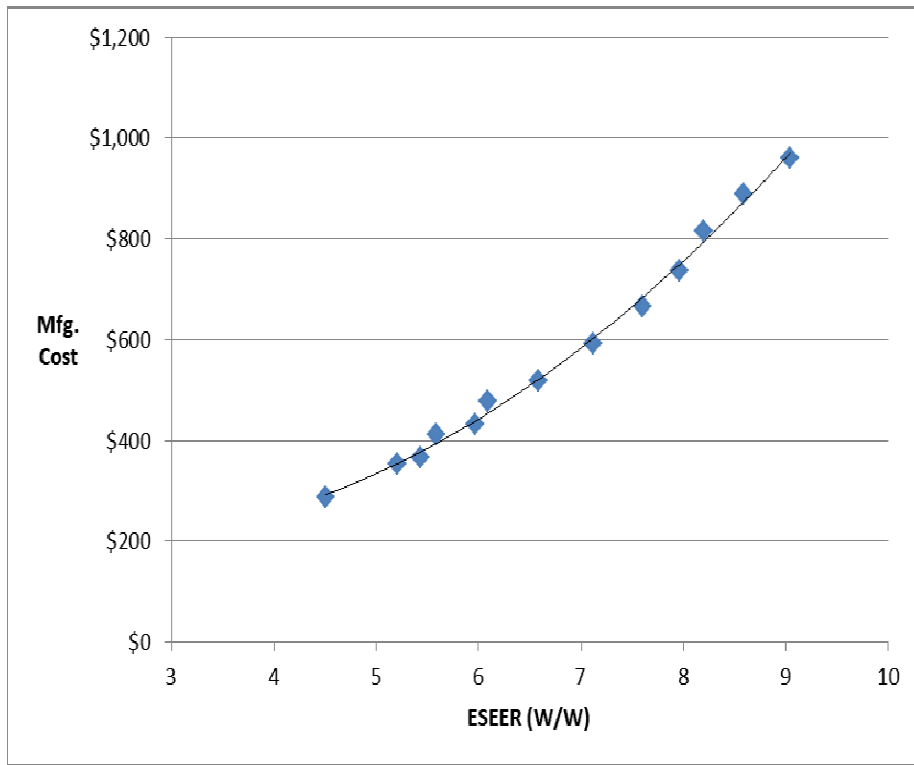

Figure B-9: Manufacturing Cost vs ESEER for Mexico

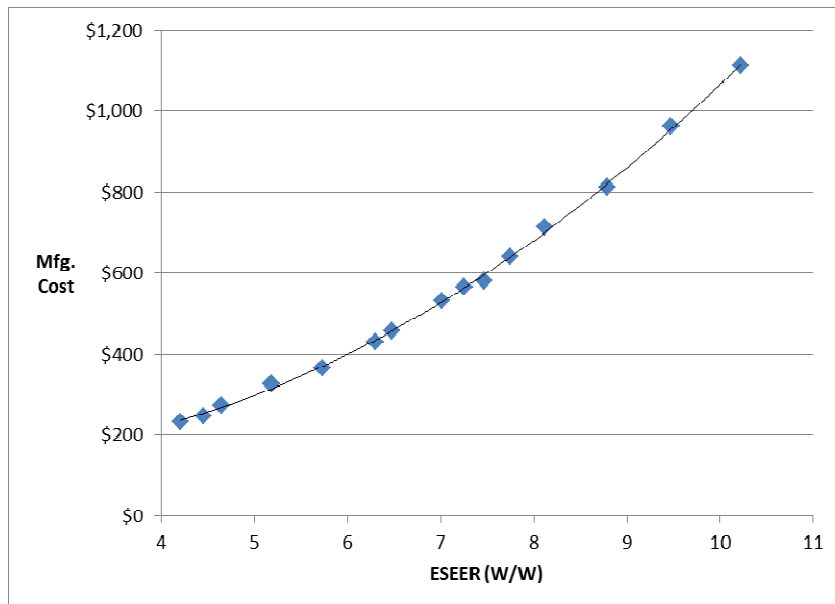

Figure B-10: Manufacturing Cost vs ESEER for Russia

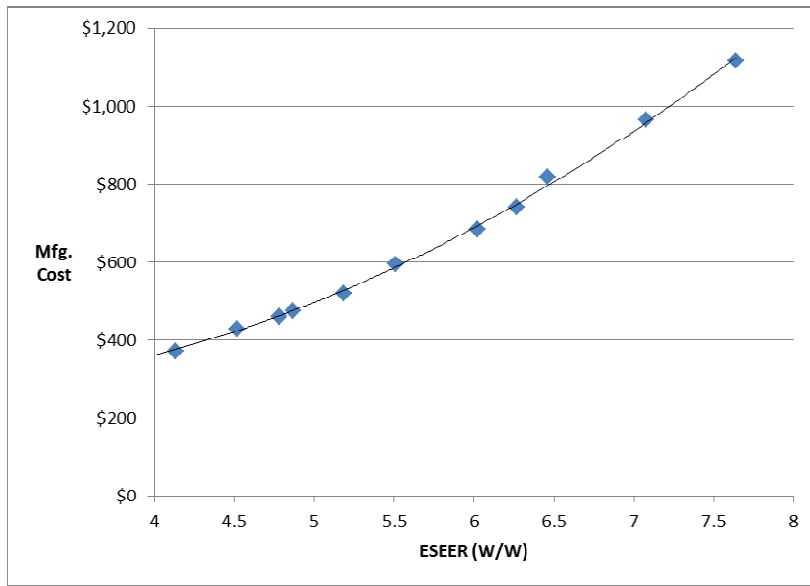

Figure B-11: Manufacturing Cost vs ESEER for UAE

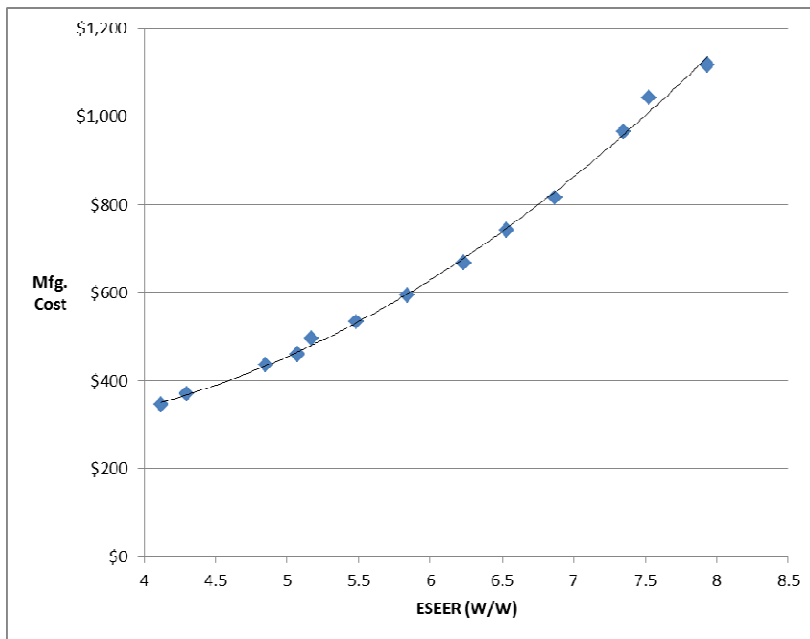

Figure B-12: Manufacturing Cost vs ESEER for USA

## Appendix C: Rebound Effect

Usually, a decrease in energy consumption is expected with an increase in energy efficiency. However, improvements in energy efficiency not only reduce energy consumption but also cause a reduction in the real per unit cost of energy services, possibly leading directly to increased demand for energy services at these lower costs (direct rebound effect), and possibly leading to increased demand for energy services flowing from the money saved due to efficiency improvement being spent on other energy consuming goods and services. (indirect rebound effect). Collectively these effects are known as the “rebound effect.”

The economic analyses and savings potential estimates presented in chapter 4 and chapter 5 respectively do not consider any form of rebound effect. While a comprehensive treatment of the rebound effect is beyond the scope of this report, we discuss briefly the recent literature on the rebound effect.

### A. Theoretical Principle

In the case of purchasing a new air conditioner that consumes less energy than an older one, if the hours of operation and the preset temperature of the new air conditioner are identical to those of the older model, the amount of energy consumption is decreased by this technological improvement. However, this improvement also reduces operating costs and *may* result in an additional demand for air-conditioning, in a situation where the air conditioning demand was constrained by costs. Increased use of energy services such as air conditioning, induced by the reduction in their costs due to greater energy efficiency is called the direct rebound effect. The mechanism underlying this effect is identical to that underlying the effects of the reduction in the price of commodity. The energy efficiency improvement could induce two kinds of increases in demand. First, it could induce an increase in demand in favor of the commodity whose price has fallen, i.e. energy services thus leading to the direct rebound. Second, it could induce an increase in demand, due to the fact that the lower price confers an increase in real income on the consumer. Holding the prices of other commodities constant, the reduction in the cost of energy services implies that the consumer has a little more money to spend on not only relevant energy goods and services but also other goods and services. Other goods and services also require energy, and thus, total energy use may increase in areas not directly affected by the energy efficiency improvement. This is called the indirect rebound effect. As a result, the anticipated energy savings from the new air conditioner may be counteracted in part by these additional demands.

The theoretical principle behind the rebound effect has been discussed extensively in the existing literature (See Greening et al., 2000 for a comprehensive review). However, there are not yet sufficient empirical studies supplementing this theoretical work, due in part due to methodological and terminological inconsistencies, and in part to the paucity of good data sets. Also, it is very difficult to isolate and attribute the correlation between a particular energy efficiency improvement and economy-wide energy use that would be required to quantify the indirect rebound effect. Henceforth, we will confine our discussion to the direct rebound effect.

As the consumption of a particular energy service increases, saturation effects (technically, declining marginal utility) should reduce the direct rebound effect. For example, direct rebound effects from improvements in the energy efficiency of household heating or room AC systems should decline rapidly once whole-house indoor temperatures approach thermal comfort. One important implication is that direct rebound effects will be higher among low-income groups, since these are further from satiation in their consumption of many energy services such as air conditioning. (Milne and Boardman, 2000).

Increases in demand may derive from existing consumers of the service, or from consumers who were previously unable or unwilling to purchase that service. For example, improvements in the energy efficiency



of space cooling equipment may reduce the cost of such equipment and therefore encourage consumers to purchase portable air-conditioners for the first time. The abundance of such consumers in developing countries points to the possibility of large rebounds in these contexts, offset to only a limited extent by saturation effects among existing consumers (Roy, 2000).

Even if energy efficiency improvements are not associated with changes in capital or other costs, certain types of direct rebound effect may be constrained by the real or opportunity costs associated with increasing demand. One example is the opportunity cost of space, (e.g. increasing AC size may not be the best use of available space).

The direct rebound effect for a particular energy service such as air conditioning may therefore vary between households and over time and may be influenced by a large number of variables.

## B. Empirical Evidence

There are only a handful of studies on the direct rebound of residential space cooling. Greening et al present a summary of 9 studies in their 2000 article, and provide a range of 0-50% for direct rebound in residential space cooling.

The two econometric studies upheld as the best measures of residential space cooling rebound studies by Greening et al. (2000) and Sorrell et al. (2009) are by Hausman (1979<sup>15</sup>) and Dubin et al (1986)<sup>16</sup>. Both these are U.S. based cross-sectional analyses with Hausman using 1978 data of sample size of 46 and Dubin et al. using 1981 data of sample size of 214-396.

These are relatively old studies, using small sample sizes. Their results may not be transferable to other geographical areas, owing to differences in house types and climatological conditions. Also, both studies focus solely upon changes in equipment utilization. To the extent that ownership of cooling technology is rapidly increasing in many countries, increased demand from ‘marginal consumers’ may be an important consideration, together with increases in system capacity among existing users.

**Table C-1 Econometric Studies of Direct Rebound for Residential Space Cooling**

Author	Year	Short-run Rebound Effect	Long-run Rebound Effect	Country
Hausman	1979	4%	26.50%	US
Dubin et al.	1986	1-26%		US (Florida)

Sorrell et al.(2009) suggest direct rebound in the range of 1-26% based on these two studies, but add that these numbers could be higher in the current times due to increased capacity and lower prices of the equipment.

### C. Summary of Rebound Effect

In summary, the accurate estimation of direct rebound effects is not straightforward and requires adequate data on energy consumption, energy services and/or energy efficiency which is only available for a small subset of energy services. As a consequence, the evidence remains sparse, inconsistent and methodologically diverse, as well as being largely confined to a limited number of consumer energy services in the OECD. Moreover, the effect is expected to decline in the future as demand saturates and income increases. Both theoretical considerations and the available empirical evidence suggest that direct rebound effects should be smaller for other consumer energy services where energy forms a small proportion of total costs. Rebound effects for space heating and other energy services are also higher among low-income groups and most studies do not account for ‘marginal consumers’ acquiring services such as space cooling for the first time.

However even with all the challenges, the literature doesn’t predict outright backfire (100% rebound) --or even large rebound-- unless there is a large untapped or unsatisfied demand. Hence it appears that within the sphere of direct rebound, the “energy saving” benefit of efficiency improvements is realizable to some extent at least for the developed economies.

Further work to quantify direct rebound in developing economies is necessary to draw further conclusions. However, we note that if the effect of rebound is to reduce the effectiveness of efficiency improvement in producing energy savings, the effect of technological learning (discussed in Section 4.2.4), is to increase the cost-effectiveness of such efficiency improvement, and therefore these effects act to counterbalance each other.

## Appendix D: Sensitivity Analysis

The cost effectiveness analysis presented in chapters 4 and 5 is sensitive to uncertainty in the underlying assumptions in discount rate, lifetime, hours of use, ESEER, and manufacturing costs. Figure D-1 below shows the sensitivity of the cost of conserved electricity to a  $\pm 10\%$  change in each variable. As expected the cost of conserved electricity is most sensitive, and non-linearly sensitive to manufacturing cost, and efficiency assumptions, while it is least sensitive (sub-linear) to assumptions about discount rate and lifetime, while it is approximately linearly sensitive to hours of use and cooling capacity assumptions. Figure D-2 shows the sensitivity of the savings potential to a  $\pm 10\%$  change in each variable. As expected savings potential varies linearly with hours of use, cooling capacity, sales, and lifetime, and non-linearly with ESEER.

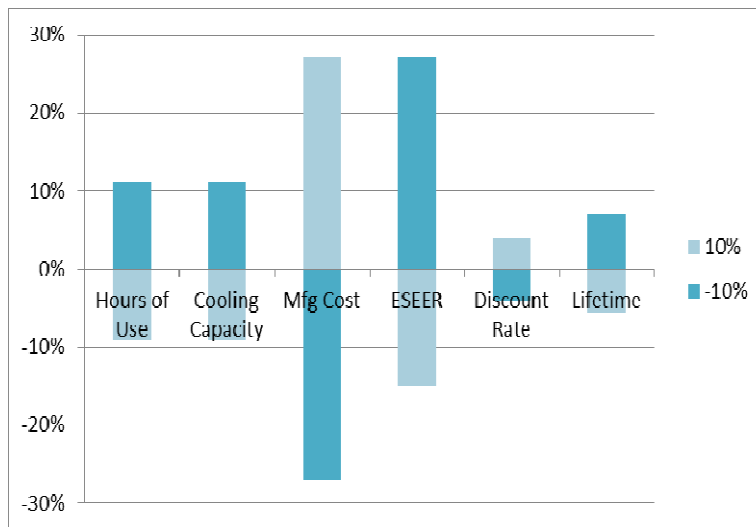

Figure D-1 Sensitivity of Cost of Conserved Electricity (CCE) to assumptions

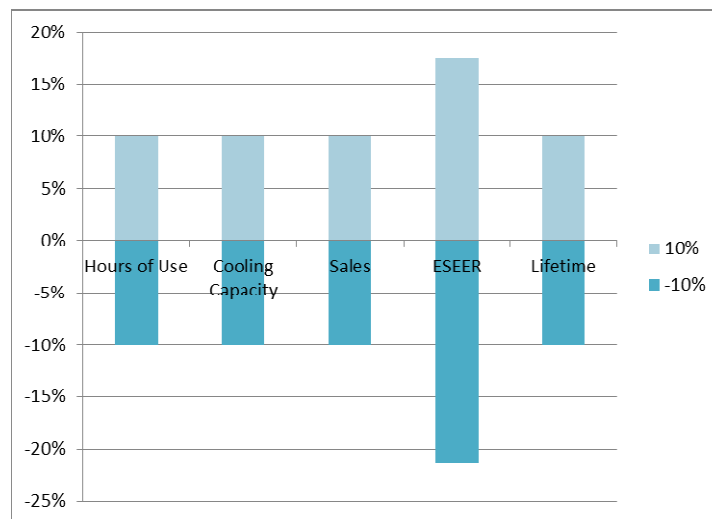

Figure D-2 Sensitivity of Savings Potential to assumptions.

### Country-specific Assumptions

The cost effectiveness analysis and energy savings potential presented in chapters 4 and 5 are sensitive to uncertainty in the underlying country-specific assumptions in discount rate, hours of use, and markup costs. These are presented here in Table D-1.

**Table D-1 Country-specific assumptions**

Country	Discount Rate	Usage Hours		Total Markup (Retailer, Sales, Installation)
		Cooling	Heating	
Australia	3.11%	310	1464	120%
Brazil	11.58%	817	None	76%
Canada	1.90%	182	2418	110%
China	1.63%	380	2140	76%
EU	6.63%	350	1400	161%
India	7.60%	1440	None	69%
Japan	3.28%	380	1421	110%
Korea	4.19%	380	2288	65%
Mexico	3.81%	200	663	74%
Russia	3.67%	53	2327	77%
UAE	6.39%	700	2250	110%
USA	1.47%	2404	None	54%