

Lawrence Berkeley National Laboratory

Recent Work

Title

DEFLECTOR POWER SUPPLY FOR SECTOR-FOCUSED CYCLOTRONS

Permalink

<https://escholarship.org/uc/item/21s2z8zw>

Author

Smith, Bob H.

Publication Date

1963-03-25

UCRL-10655

University of California
Ernest O. Lawrence
Radiation Laboratory

**DEFLECTOR POWER SUPPLY
FOR SECTOR-FOCUSED CYCLOTRONS**

TWO-WEEK LOAN COPY

*This is a Library Circulating Copy
which may be borrowed for two weeks.
For a personal retention copy, call
Tech. Info. Division, Ext. 5545*

DISCLAIMER

This document was prepared as an account of work sponsored by the United States Government. While this document is believed to contain correct information, neither the United States Government nor any agency thereof, nor the Regents of the University of California, nor any of their employees, makes any warranty, express or implied, or assumes any legal responsibility for the accuracy, completeness, or usefulness of any information, apparatus, product, or process disclosed, or represents that its use would not infringe privately owned rights. Reference herein to any specific commercial product, process, or service by its trade name, trademark, manufacturer, or otherwise, does not necessarily constitute or imply its endorsement, recommendation, or favoring by the United States Government or any agency thereof, or the Regents of the University of California. The views and opinions of authors expressed herein do not necessarily state or reflect those of the United States Government or any agency thereof or the Regents of the University of California.

Research and Development

UCRL-10655
UC-28 Particle Accelerators and High-Voltage Machines
TID-4500 (19th Edition)

UNIVERSITY OF CALIFORNIA

Lawrence Radiation Laboratory
Berkeley, California

Contract No. W-7405-eng-48

DEFLECTOR POWER SUPPLY
FOR SECTOR-FOCUSED CYCLOTRONS

Bob H. Smith

March 25, 1963

DEFLECTOR POWER SUPPLY
FOR SECTOR-FOCUSED CYCLOTRONS

Bob H. Smith

Lawrence Radiation Laboratory
University of California
Berkeley, California

March 25, 1963

ABSTRACT

Because of the higher particle energy, sector-focused cyclotrons require higher gradients in their electrostatic deflectors than ordinary cyclotrons. A higher operating gradient can be achieved by exciting the deflector from a low-energy-storage power supply which permits control of the electrode surface heating during each spark. A pair of high-frequency Cockcroft-Walton rectifiers with this capability has been built for the Lawrence Radiation Laboratory's 88-Inch Cyclotron. Each rectifier consists of a six-stage circuit designed to deliver 120 kV at 5 mA. It is driven by a 100-kc oscillator. The rectifier is built from inexpensive silicon diodes, each with a rating of 600 pV, 0.75 A, and a storage time of 2 μ sec. The diodes are assembled on etched circuit boards. Between decks of the rectifier, 900-pF, 30-kV ceramic capacitors similar to those in television sets are used. The dc output voltage is controlled by plate modulation of the oscillator and regulated to 0.01% by an electronic regulator. The rectifier is protected against spark-induced surge currents by an electronic crowbar operating on the screen grid of the oscillator.

DEFLECTOR POWER SUPPLY
FOR SECTOR-FOCUSED CYCLOTRONS*

Bob H. Smith

Lawrence Radiation Laboratory
University of California
Berkeley, California

March 25, 1963

INTRODUCTION

The state of the cyclotron art demands well-regulated, ripple-free voltage for the new high-gradient electrostatic deflectors. Higher electrical gradients can be achieved if the deflector power supply provides a simple means of adjusting the energy supplied to the sparks during the deflector bake-in period. The power supply described here meets these requirements remarkably well. Two such supplies have been built and installed in the Berkeley 88-Inch Cyclotron. Each supply consists of a six-stage Cockcroft-Walton rectifier built from silicon diodes mounted on printed-circuit boards, a 100-kc oscillator to excite the rectifier, a hard-tube modulator to control the oscillator output voltage, an electronic regulator, a reference, and a precision voltage divider (see Fig. 1).

The rectifier installed in the cyclotron is shown in Fig. 2. It consists of 12 circuit boards mounted in an 8-in. -o. d. lucite tube; the overall length of the assembly is 27 in. The rectifier extends from slightly above the deflector bushing to the ceiling of the deflector cage. The 100-kc oscillator is mounted directly above the rectifier on the roof of the deflector cage. It connects to the rectifier through a fiberglass insulator. The rest of the electronic equipment is installed in the electronic racks.

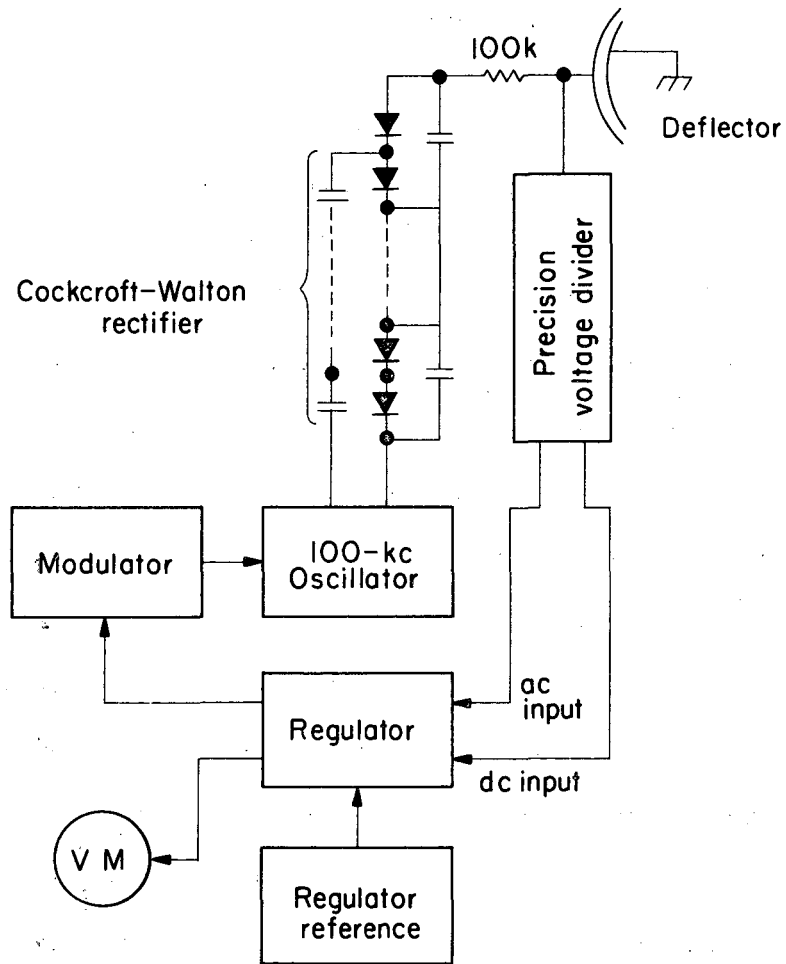

MU-30061

Fig. 1. Master schematic of deflector power supply.

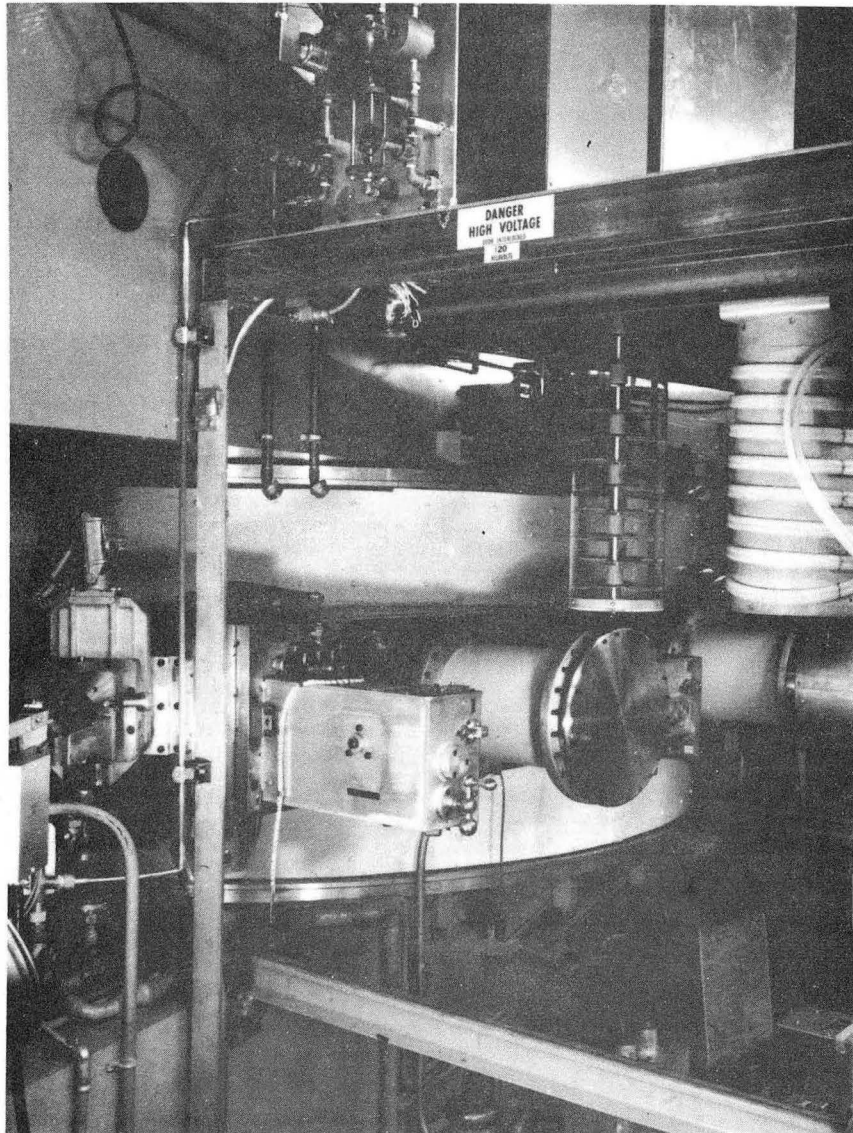

ZN-3708

Fig. 2. Deflector rectifier installed in the 88-Inch Cyclotron. It extends from the deflector bushing to the ceiling of the deflector cage. It has an outside diameter of 8 in. and is 27 in. tall.

RECTIFIER

Each circuit board consists of 100 Unitrode, Type UT71, silicon diodes connected in series. Each diode is shunted by a 250-pF, 500-V, ceramic capacitor to divide the inverse voltages equally. The diode pattern on the circuit board is arranged to minimize the voltage gradient across the board (see Fig. 3). The boards are connected electrically at two points; by a metal post at one point and by the between-decks capacitor at another. In the vicinity of the metal post, where the potential difference is small, the capacitors and diodes face one another, while in the vicinity of the between-deck capacitors, where the potential difference is as much as 20 kV, the capacitors and diodes are on opposite sides of the boards (Fig. 4). The spacing between boards is about 2 in. and provides a nominal maximum design gradient of 10 kV per in.

The between-decks capacitors are 900-pF, 30-kV, ceramic, tv type capacitors. The manufacturer of the diodes rates each diode at 600 pA and 750 ma for 60-cycle operation. The schematic of the rectifier is shown in Fig. 5.

Since no data were available about the diodes at 100 kc, we set up a test for this purpose. Using a single diode rectifying negatively into a 10,000-ohm unbypassed load resistor, we obtained oscillograms like the one shown in Fig. 6 for the Unitrode diode (which was the best of the diodes tested). The overshoot is caused by the stored charge in the diode junction. Apparently the storage time is about two μ sec at this voltage (150 V peak). We found that the diode charges a capacitive load to the peak value, and the stored charge does not subtract (appreciably, at any rate) from the output voltage. Therefore, in the type of service for which this power supply is designed, the charge stored in the junction seems to have no appreciable effect.

At the suggestion of E. Diebold of the International Rectifier Corp., we bombarded some of the diodes with electrons in our 5-MeV electron linear

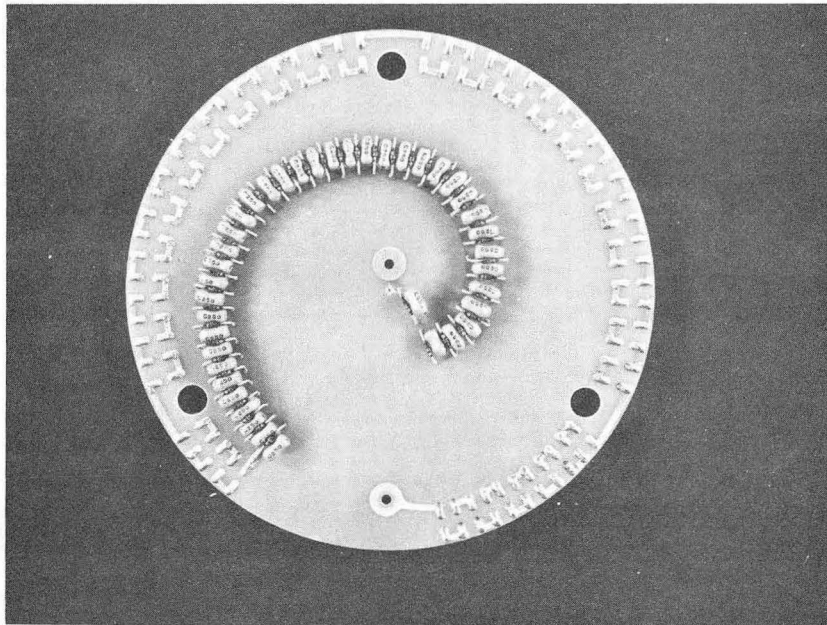
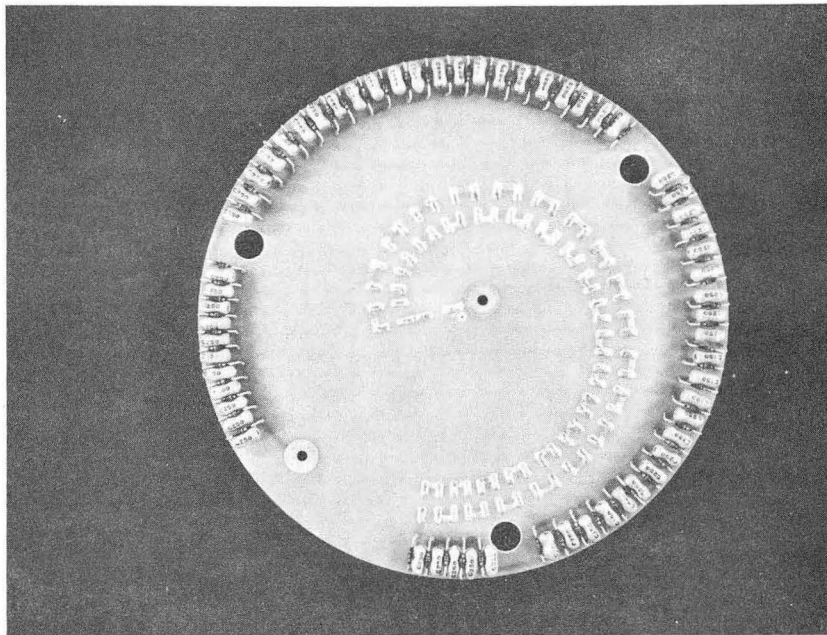

ZN-3703

Fig. 3. Both sides of a printed-circuit board. The diode pattern is arranged to minimize the voltage gradient across the board. In the vicinity of the between-deck capacitors of the Cockcroft-Walton rectifier, the diodes are placed outboard of the capacitors to provide maximum clearance between the high-voltage points.

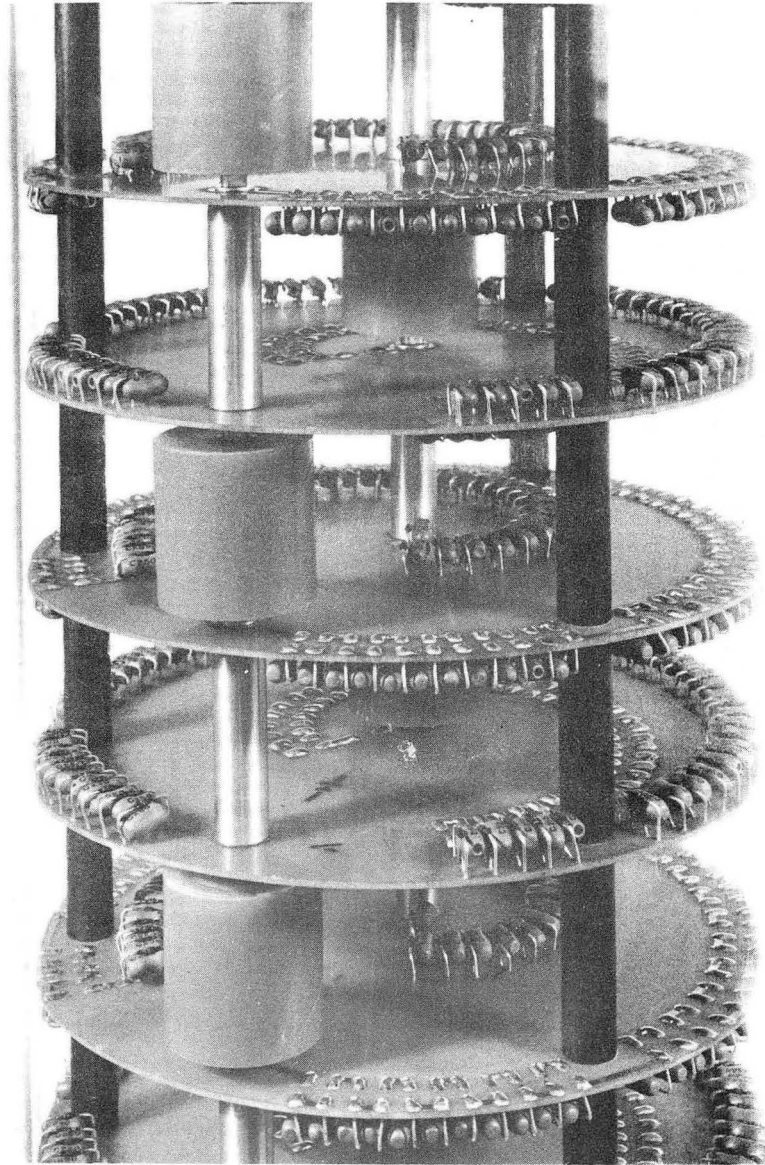

ZN-3707

Fig. 4. Close-up view of the rectifier assembly, showing the details of the construction.

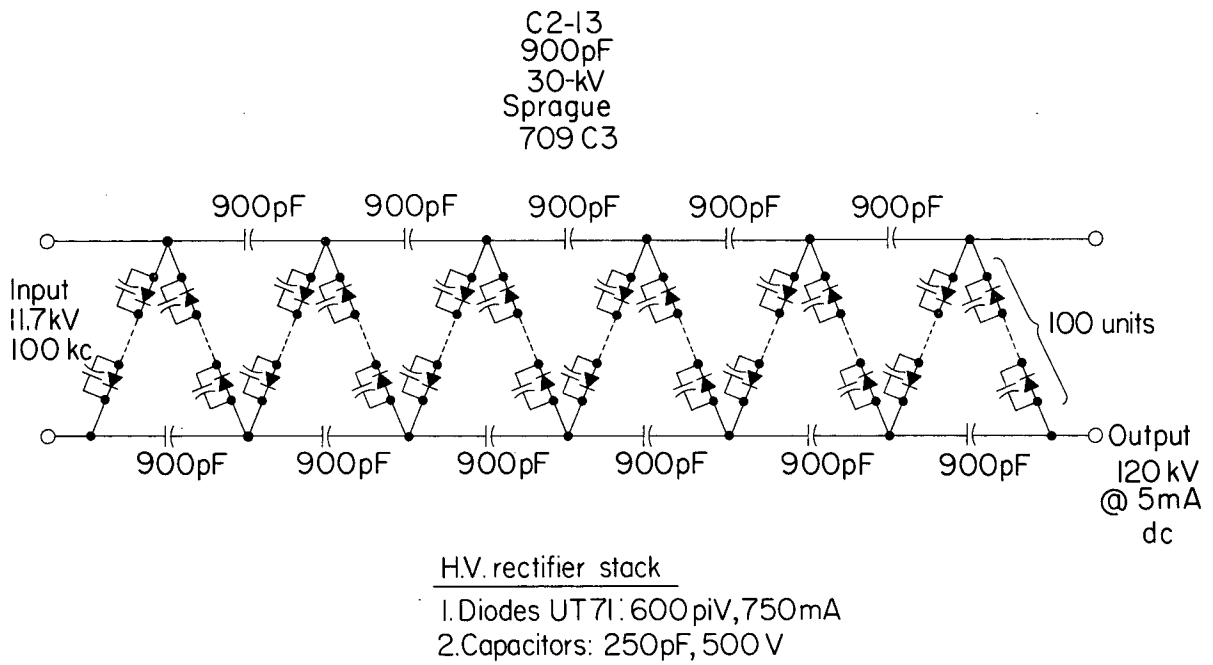

MU-30063

Fig. 5. Schematic diagram of the deflector rectifier.

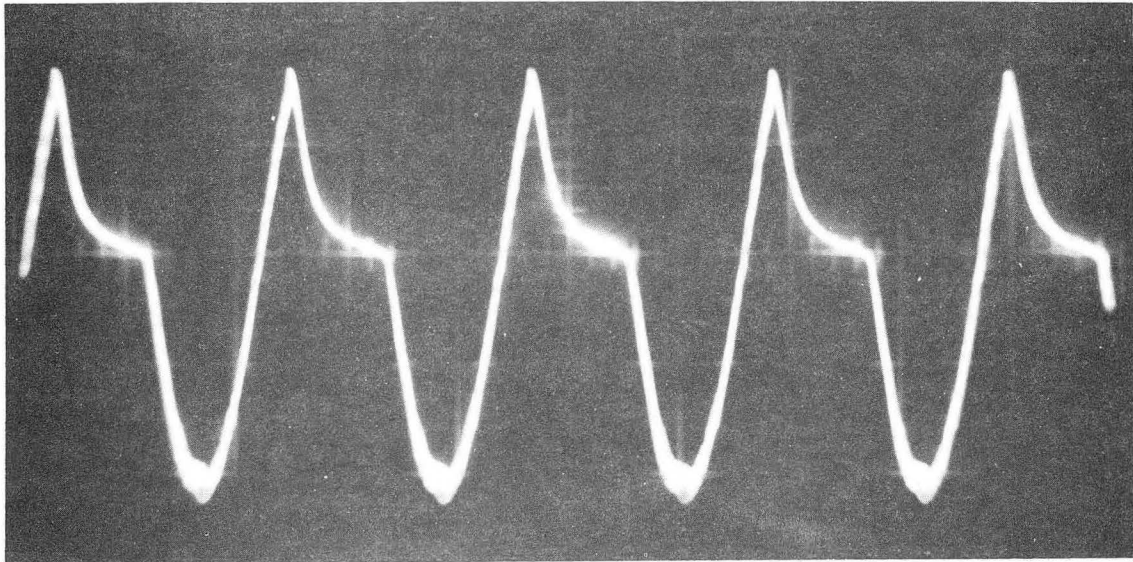

ZN-3702

Fig. 6. Wave form obtained across a $10,000\text{-}\Omega$ load resistor for a single Unitrode UT71 diode. The peak value of the applied voltage was 150 V, and the frequency was approximately 100 kc. The overshoot shows the storage time of the diode junction at this voltage--about $2\ \mu\text{sec}$. When the rectifier load is shunted by a sufficiently large capacitor, the capacitor charges to the peak value as though the diode-junction-stored charge were not present.

accelerator. This improved rectification, as shown in Fig. 7. The beam-current density was $400 \mu\text{A}/\text{cm}^2$. The optimum bombardment time with this beam was 17 min.

We wondered whether the electron irradiation had any effect on the inverse characteristic of the diode. We found that it reduced the apparent resistance by a factor of 10. It had no appreciable effect upon the avalanche breakdown voltage, which was about 900 V for these diodes. The back resistance was reduced to about $200 \text{ M}\Omega$ for each diode. This is still enormously high compared with any load that the rectifier might be called upon to feed, so there appears to be no reason why irradiated diodes can not be used. It appears that rectifiers can be built to operate at much higher frequencies than the 100 kc, if desired. We decided that in our application we did not have to irradiate the diodes, so we used them as they came from the manufacturer. Irradiation is mentioned here for those who might want to operate at frequencies above 100 kc.

OSCILLATOR

The oscillator consists of an Eimac 4CW2000 in a Colpitts circuit (Figs. 8 and 9). Several other circuits were studied, but the Colpitts circuit provided the greatest discrimination against parasitic oscillations. The turns ratio of the tuned circuit is five to one, so a 2500-V oscillator plate swing produces 12.5 kV peak rf. This is applied directly to the Cockcroft-Walton rectifier which multiplies it to 120 kV dc. The frequency of the oscillator is 100 kc.

The 3D22 thyatron serves as the crowbar; when fired it effectively grounds the screen grid of the oscillator and prevents oscillation. The 3D22 is built so that the anode discharge occurs between the anode and the shield grid rather than anode to cathode. The shield grid is much larger than the anode and surrounds it completely. The control grid and cathode form an electron gun that shoots a stream of electrons through a hole in the shield grid

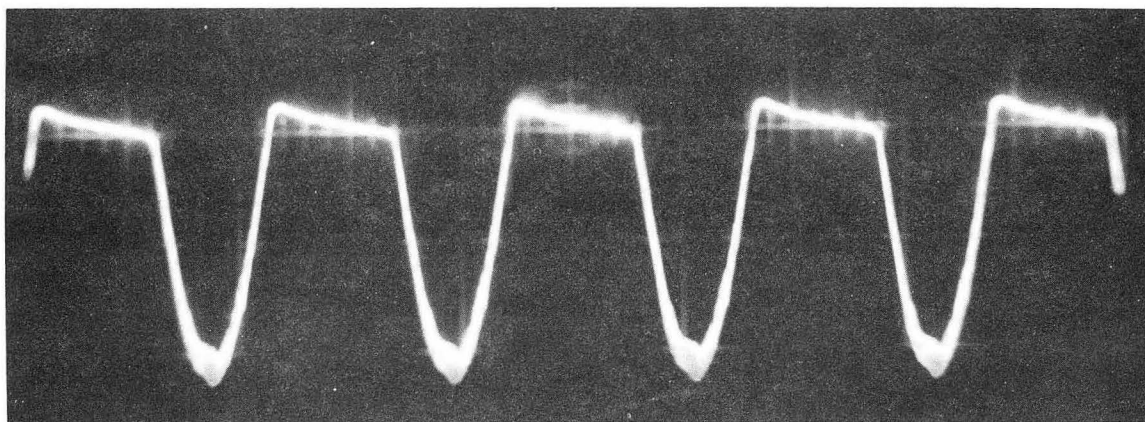

ZN-3701

Fig. 7. After irradiating the diode with a beam of 5-MeV electrons the rectification characteristics of the diode is much improved. The diode was bombarded with a beam-current density of $400 \mu\text{A}/\text{cm}^2$ for 17 min.

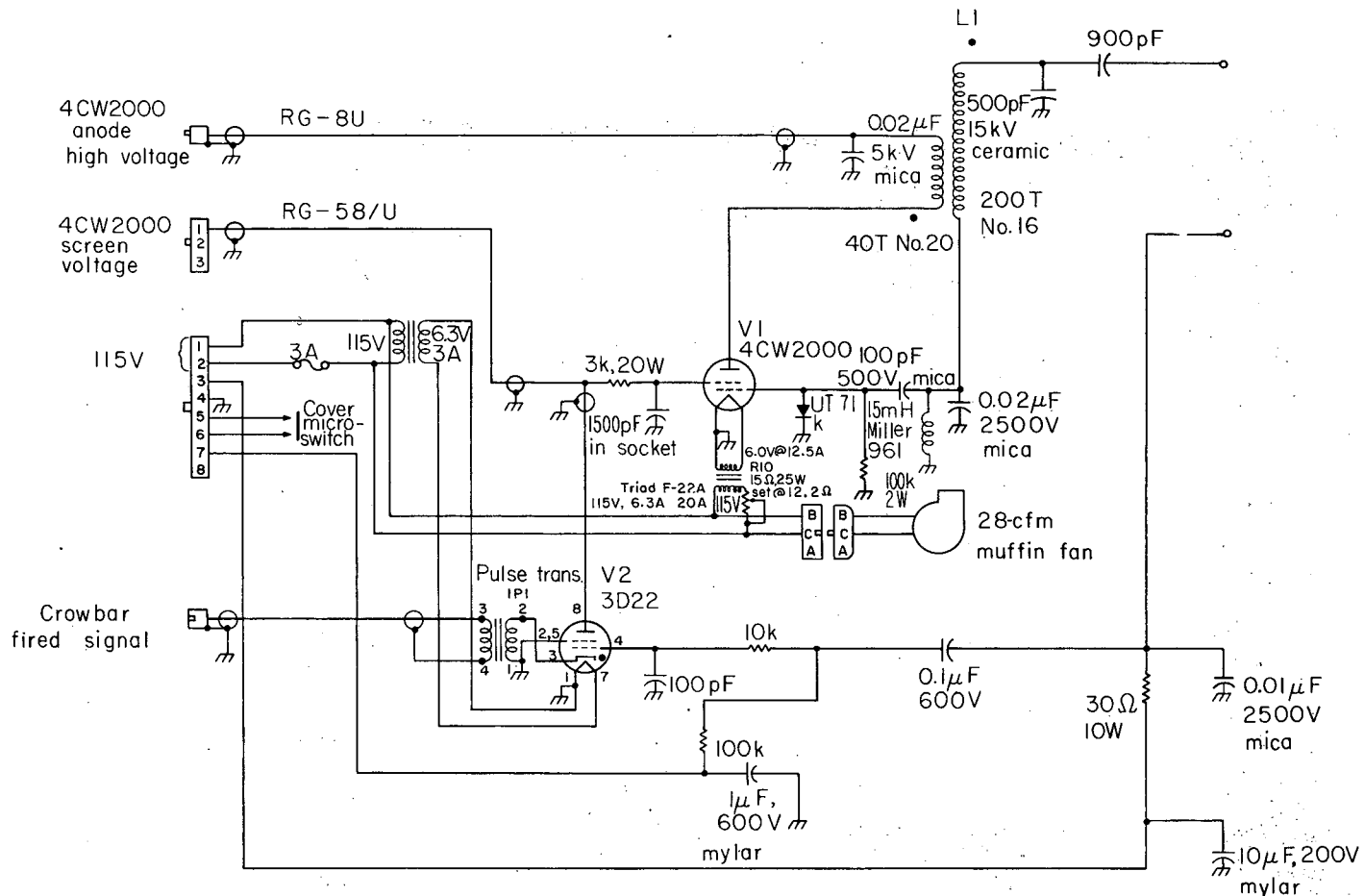

MUB-1705

Fig. 8. The 100-k oscillator is a Colpitts circuit. The 3D22 thyatron serves as a crowbar and removes the screen voltage of the oscillator upon an overcurrent in the Cockcroft-Walton rectifier.

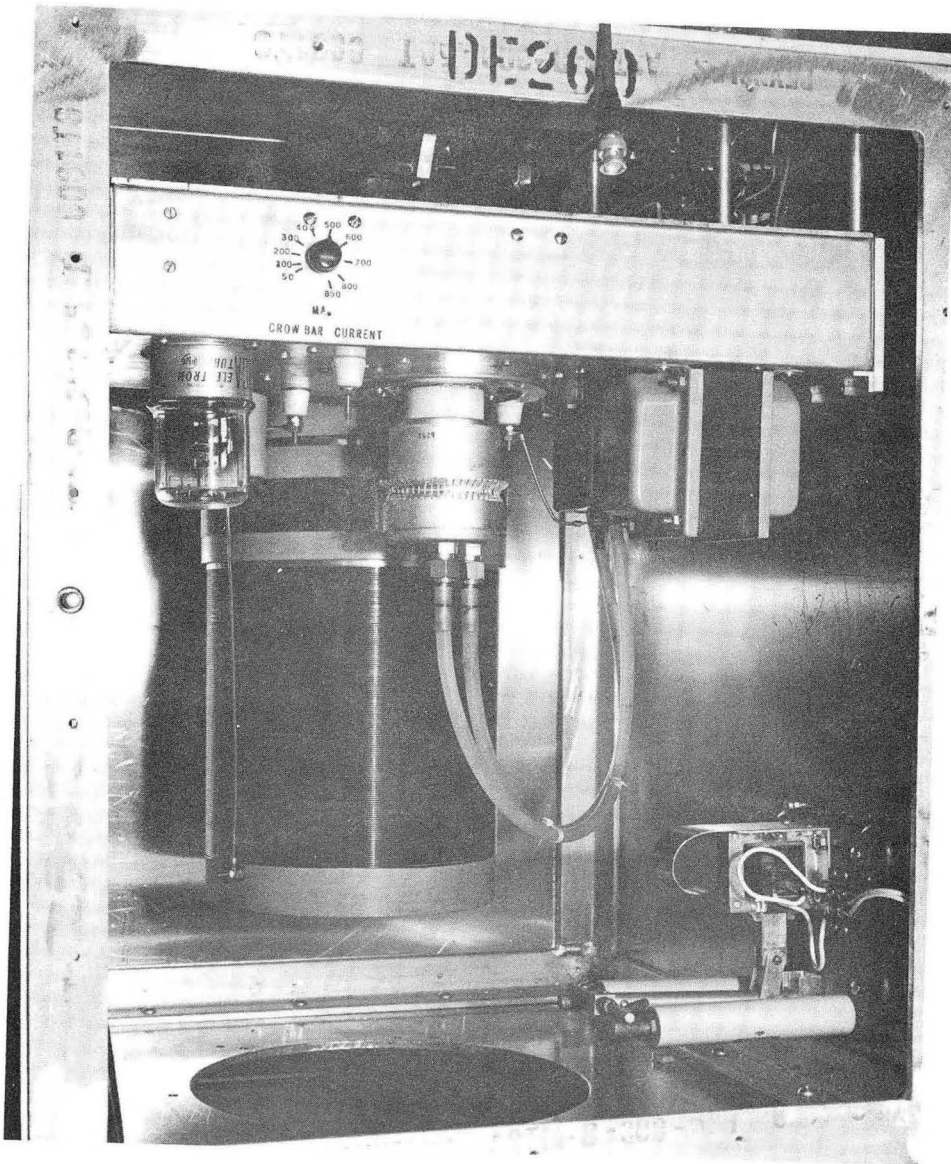

ZN-3704

Fig. 9. Construction details of the 100-kc oscillator.

into the gaseous region between the shield grid and anode, thus initiating the discharge. A pulse transformer is connected in series with the cathode so that, when the grid is triggered, the cathode current produces a pulse that trips the transistor univibrator, which recycles the screen power supply. The recycling time is 1 sec.

The crowbar derives its signal from the 30-ohm shunt resistor in the ground return of the rectifier. Capacitive coupling is used so that the crowbar sensitivity can be controlled by a thyatron bias adjustment. Direct-current protection is provided by an overcurrent relay located outside the oscillator. The RC filter at the thyatron grid prevents triggering of the thyatron by the rf. During a spark, of course, this circuit integrates the current for a period before firing the thyatron; typically, it takes a few microseconds. Because of this circuit the time that a spark discharge persists is a function of the setting of the crowbar bias control.

Since the deflector oscillators are located close to the magnet yoke of the cyclotron in a field of about 150 G, magnetic shields had to be put over the 4CW2000 oscillator tube and the 3D22. The shields consisted of tight-fitting, 1/8-in. -thick, mild-steel cylindrical caps.

MODULATOR

The oscillator output voltage is controlled by adjusting the oscillator plate voltage by means of an Eimac 4CX1000A hard-tube modulator (see Fig. 10). It is driven by a 4-125A tube operating as a voltage amplifier; its primary purpose is simply to couple the signal from ground potential to the grid potential of the hard-tube modulator.

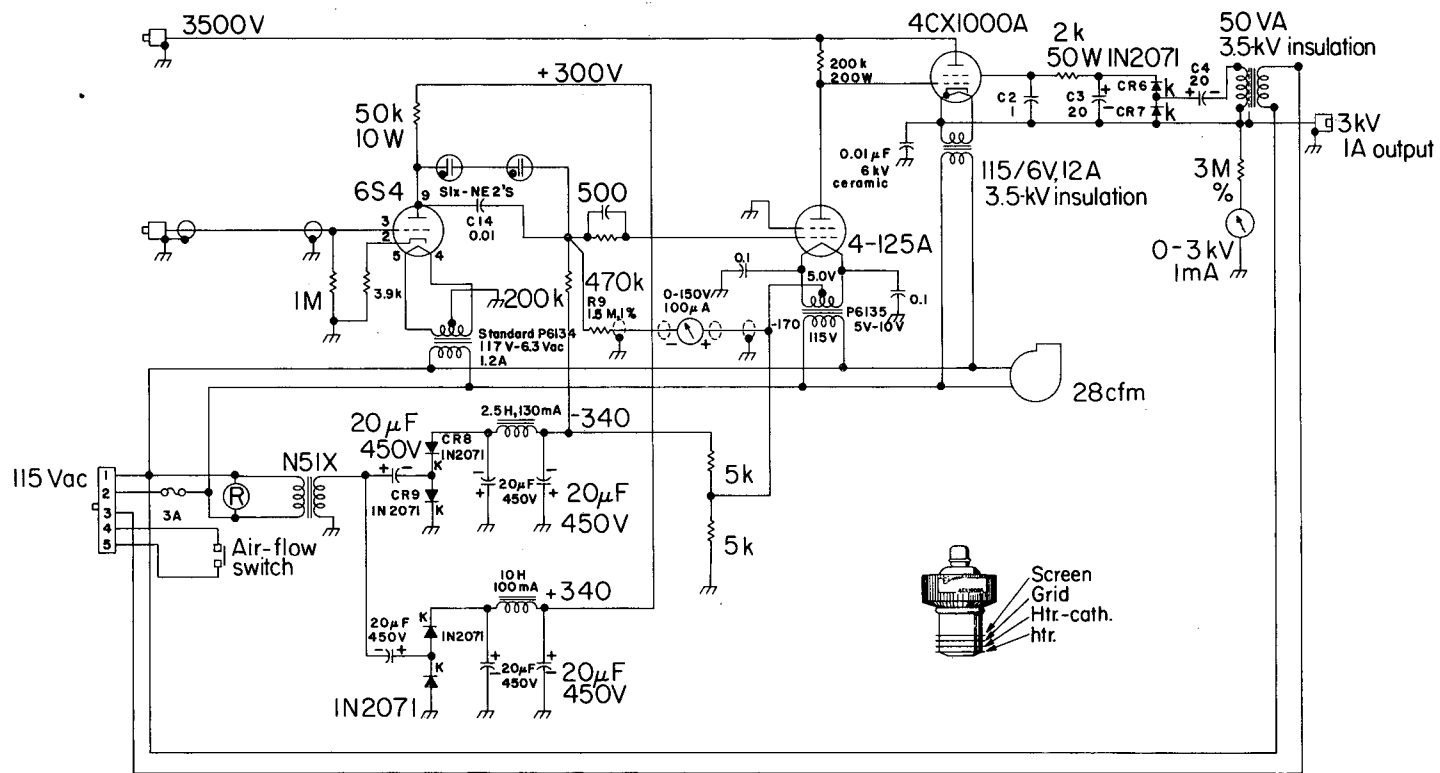

MUB-1704

Fig. 10. Hard-tube modulator. This circuit controls the deflector voltage by modulating the plate voltage of the 100-kc oscillator.

REGULATOR

A two-loop regulator is used to provide deflector voltage stabilization (Fig. 11). The dc loop employs a chopper amplifier to eliminate drift. The input signal of the ac loop is isolated from the noise associated with the input chopper. The unity gain frequency of the regulator loop is 2500 cycles; the transfer function is compensated to be a one-pole network. The dc-loop gain is 1,000.

REGULATOR REFERENCE

The regulator reference voltage is obtained from an 8.3 V, type 1N430A zener diode. This circuit is identical with the references used in our precision magnet regulators and is stable to better than a part in 10,000 (Fig. 12).

PRECISION VOLTAGE DIVIDER

The voltage divider consists of 120 metal-film (MF), precision resistors with a temperature coefficient of less than 36 ppm/°C. These resistors are mounted on the inside of a piece of 7-in. -o. d. polyvinyl chloride (PVC) plastic tube which provides a smooth surface for the termination of electric field lines and prevents corona (Figs. 13, 14, and 15). A fan located in the base of the mounting for the voltage divider circulates air over the resistors and keeps them at a uniform temperature. This voltage divider is the limitation on the stability of the deflector voltage; for a stability of 0.01% the temperature difference between resistors must be within about 3°C.

DEFLECTOR VOLTMETERS

The deflector voltmeter (Fig. 16) is designed to operate either as a direct-reading voltmeter or, at the selection of the operator, as a suppressed-zero voltmeter. In the direct-reading position, the voltmeter reads from

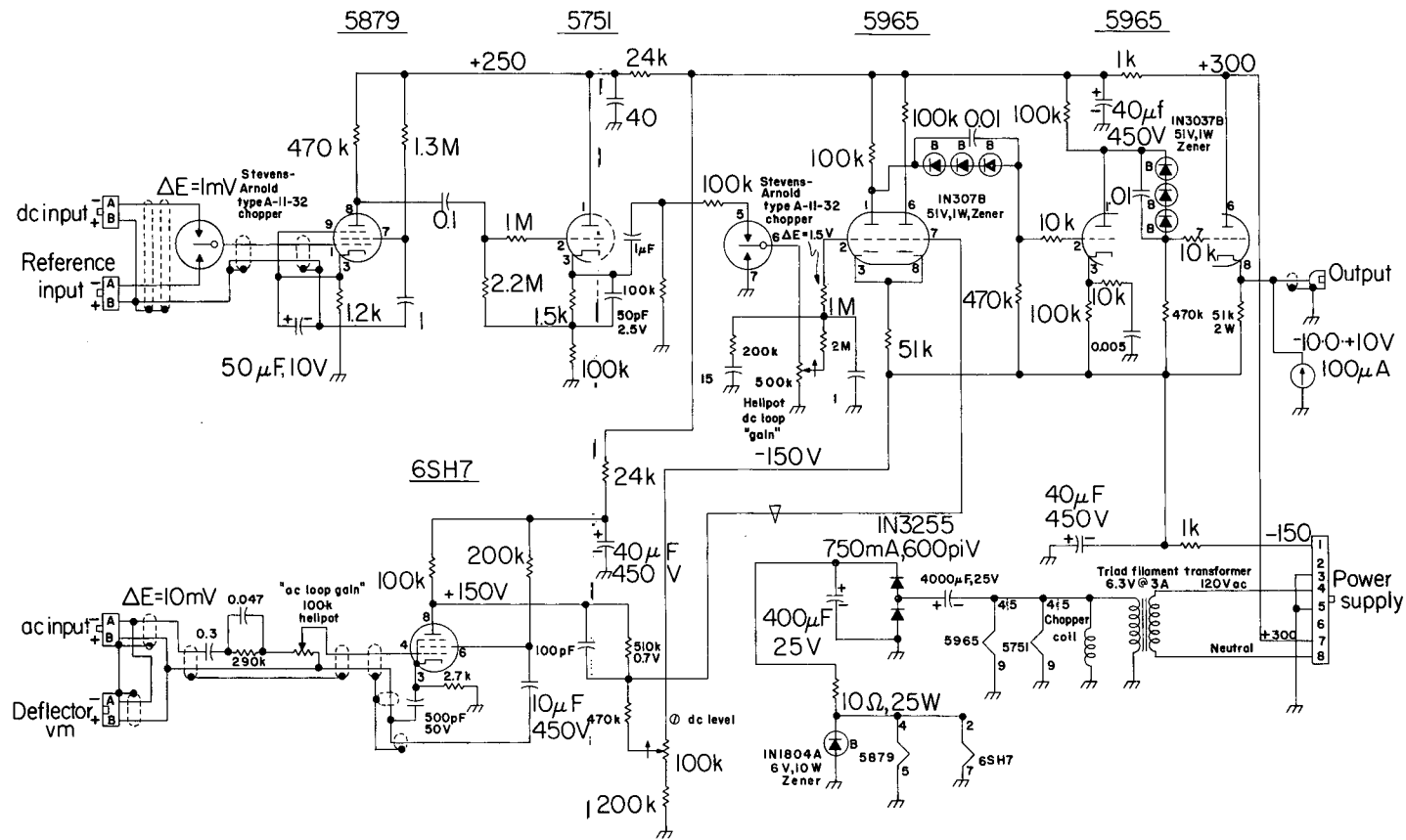
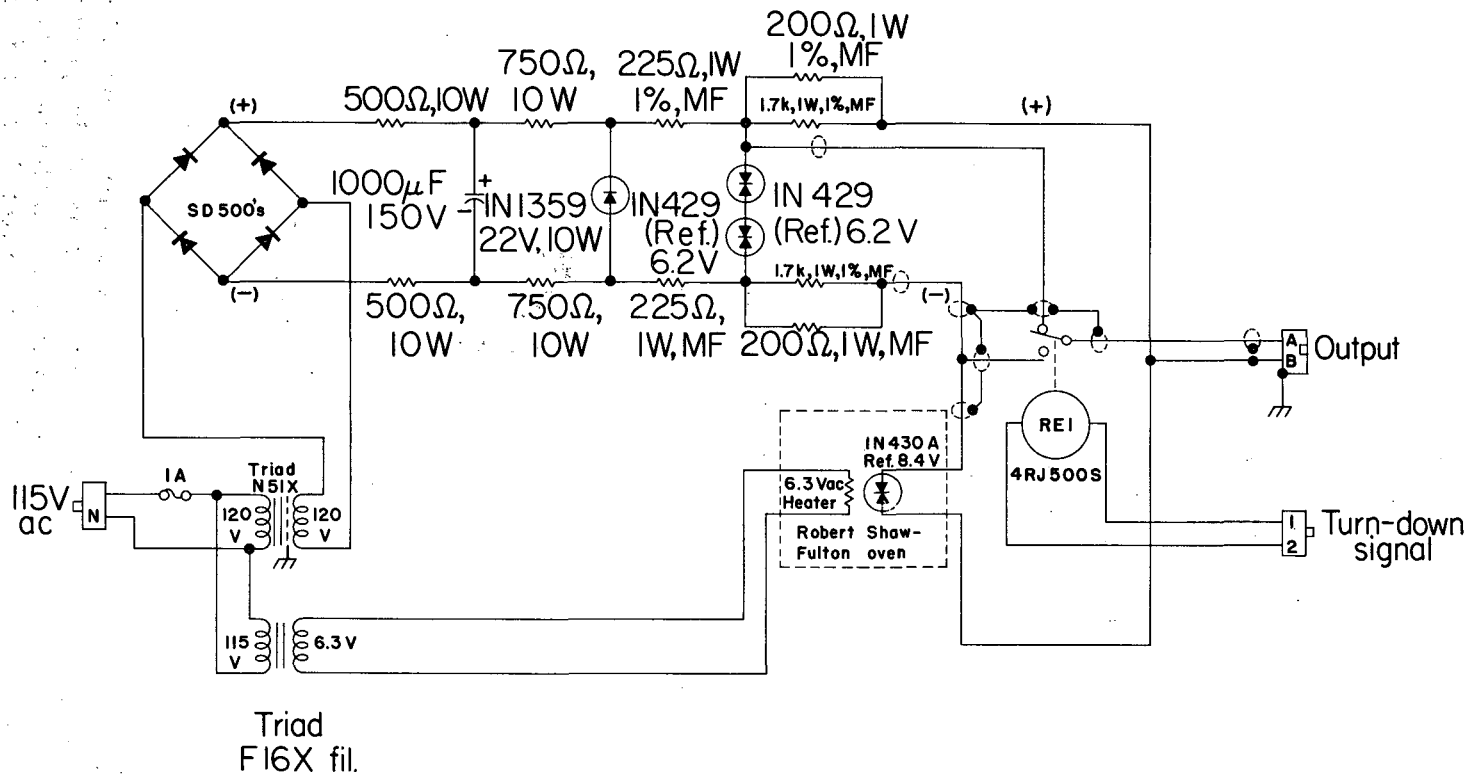

Fig. 11. Regulator amplifier schematic.

MUB-1702



MUB-1701

Fig. 12. Regulator reference schematic. This circuit is identical with the references used in our precision magnet regulators and is stable to better than one part in 10,000.

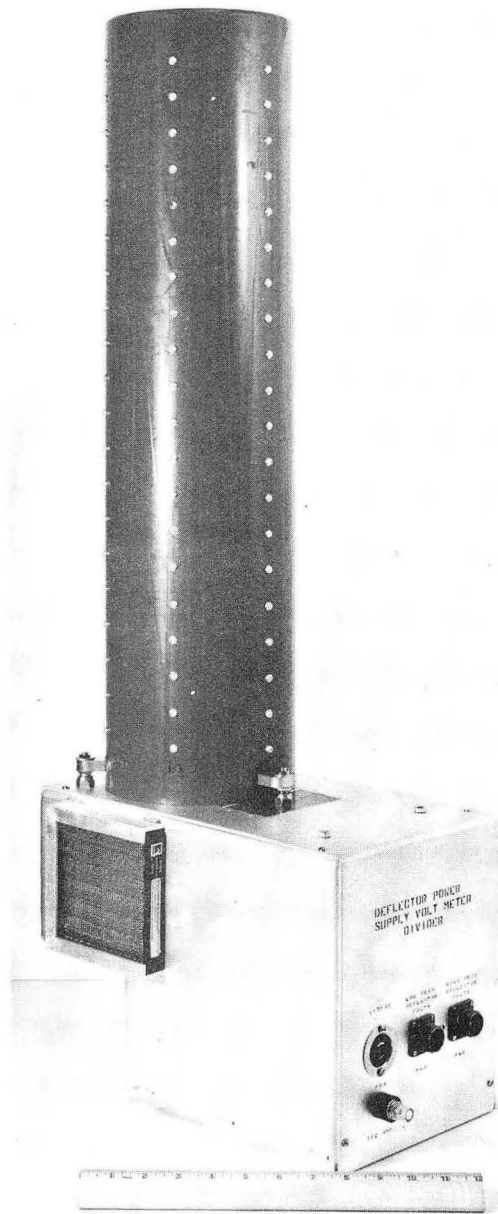

ZN-3705

Fig. 13. The precision voltage divider. Metal-film-type (MF) precision resistors are mounted on the inside of the polyvinyl chloride (PVC) plastic tube. A fan located in the base of the unit circulates air over the resistors to maintain a uniform temperature.

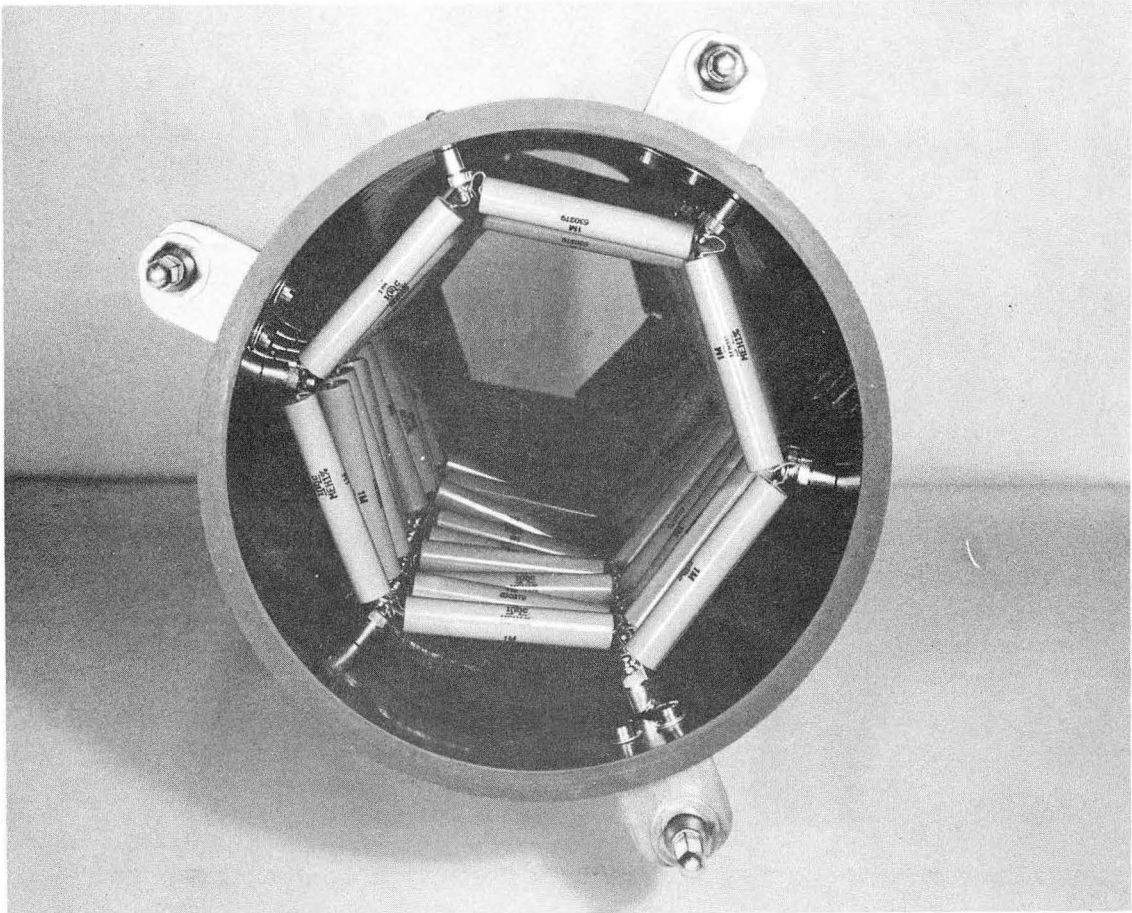

ZN-3706

Fig. 14. Interior view of the PVC plastic tube, showing the mounting of the metal-film resistors.

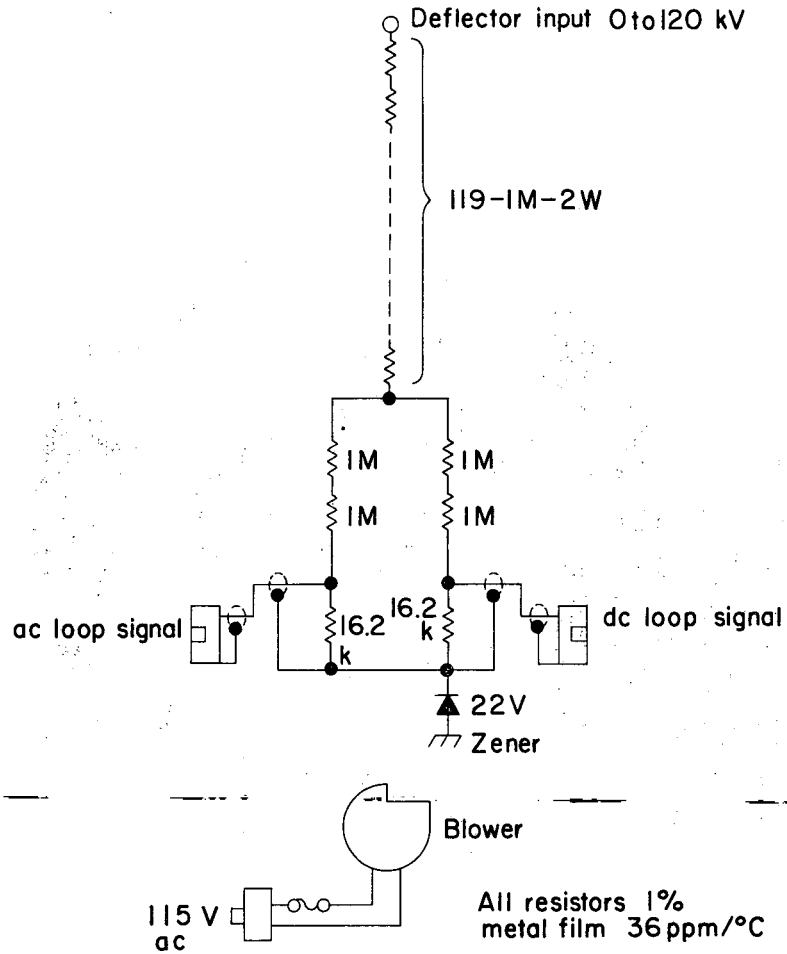

MU-30062

Fig. 15. Schematic diagram of the precision voltage divider.

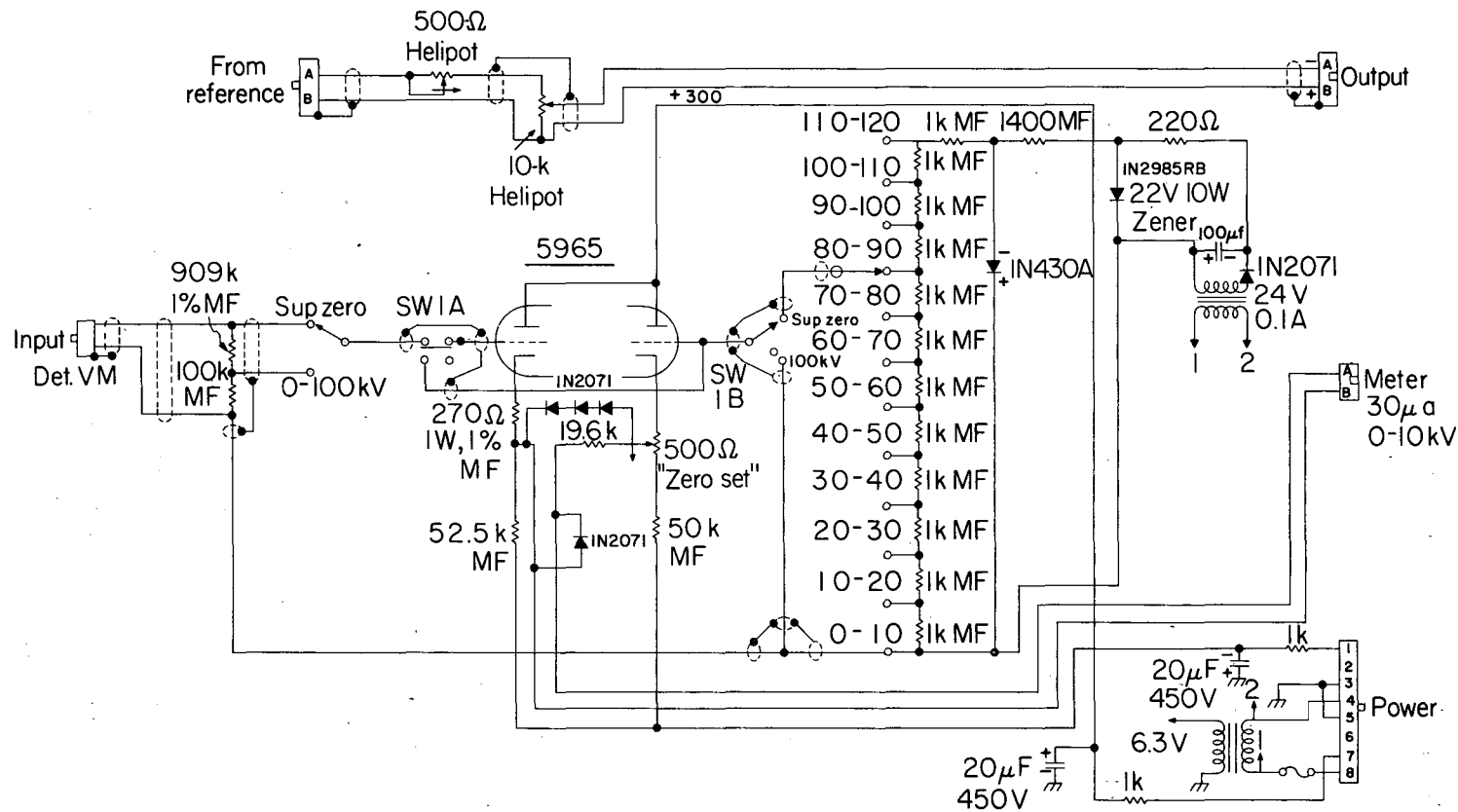

Fig. 16. Schematic diagram of the deflector voltmeter. The deflector voltmeter operates either with a zero-to-100 kV scale or with suppressed-zero scales. In the latter case the meter deflection is 10 kV and decade voltages are suppressed. The suppressed-zero scales are provided up to 120 kV, which is the limit of the deflector power supply.

MUB-1703

zero to 100 kV; in the suppressed-zero position, the meter has a 10-kV span and covers 120 kV in 12 scales. This permits the deflector voltage to be read to approximately 100 V. The absolute accuracy of the instrument is about 2%; the reproducibility is about 0.01%.

CONCLUSION

Apparently, integration of the spark current starts on the dark current preceding the actual spark, because at the more sensitive positions of the crowbar current setting, the power supply can be turned off before a spark becomes visible. By decreasing the crowbar sensitivity slightly, one can finally see a small arc during sparking; when the sensitivity is decreased further the arc becomes much brighter; finally, when it is decreased still further, it becomes a very heavy arc. Thus, one has very good control over the amount of spark-produced heating of the electrode surfaces. A second advantage of this type of power supply is that the high carrier frequency results in a very wide bandwidth in the regulator loop, making possible a very high degree of regulation. ~~The only limitation seems to be the stability of the resistors in the voltage divider.~~ A third advantage of the power supply is that it withstands the short-circuit currents associated with sparking well. We had the power supply sparking virtually every second, 24 h/day for many days without any indication of difficulty. I think, basically, the reason for this is that it stores only $2\frac{1}{2}$ joules and, at most, this is distributed among 1200 diodes. Even if all of the energy were to end up in them, (which of course it does not) there is so little energy per diode that no damage results. There is so little energy in a spark from this rectifier that it will not puncture even a piece of 5-mil aluminum foil.

ACKNOWLEDGMENTS

Development of this power supply involved the total electrical team of the 88-In. Cyclotron. Coordination was handled by Messers Warren Dexter, and Horace Warnock. In addition, Mr. Warnock worked out the layout for the printed-circuit board. Bench-checking and debugging of the chassis was done largely by Messers Phillip Frazier and Roger Regier. The system was installed by the Installation Crew under the direction of Mr. Manuel Enos. The installed system was checked out by the Electronics Maintenance crew under the direction of Mr. James Burke. The mechanical design of the Cockcroft-Walton rectifier is by Mr. Roy Burton. Mr. Kenneth Mirk also contributed to the mechanical design and construction of the system.

APPENDIX . DESIGN OF THE COCKCROFT-WALTON RECTIFIER

A. Calculation of the Output Voltage

The design specifications for the rectifier are:

1. Output voltage -- 120 kV
2. Output current -- 5 mA
3. Operating frequency -- 100 kc
4. Output ripple -- 0.2%.

The output voltage of a Cockcroft-Walton rectifier is reduced by the voltage drop in the between-deck capacitors caused by the diode shunting capacitance and the load current. The output voltage of a practical Cockcroft-Walton rectifier¹ is

$$V_{dc} = V_0 (C_s/C)^{-1/2} \tanh \left[n(C_s/C)^{1/2} \cos \theta_1 \right] - \left(\frac{n^3}{12} + \frac{3n^2}{16} \right) \frac{i_L}{sC} \quad (1)$$

Here V_0 , the peak applied ac voltage, is 10 kV; n , the number of decks, is 12; C_s , the diode shunting capacitance, is $(250 + 25)/100 = 2.75$ pF; C , the capacitance per deck, is 900 pF; θ_1 , the half angle of current flow, is 0%; i_L , the load current, is 5 mA; and $s = 2\pi f = 2\pi \times 10^5$. Substituting these values into Eq. (1) gives $V_{dc} = 103$ kV.

B. Calculation of the Ripple and Design of an RC Filter

Voelker gives the ripple voltage of a Cockcroft-Walton rectifier as¹

$$\delta E = V_0 \left[1 - \frac{1}{\cosh(n(C_s/C)^{1/2})} \right] + \left(\frac{n^2}{8} + \frac{n}{4} \right) \frac{i_L}{fC} \quad (2)$$

Substituting in Eq. (2) the values given above for Eq. (1) gives $\delta E = 3.02$ kV.

The percent ripple at the output of the Cockcroft-Walton rectifier is

$$(3.02 \times 100)/103 = 2.93\%.$$

We can attenuate this ripple by using an RC filter consisting of a series resistance connecting the Cockcroft-Walton to the deflector, and a capacitance which is the deflector capacitance. Such a filter is a one-pole network in

which, for an attenuation of 15 at 100 kc, the pole must be at 6.7 kc. For a deflector capacitance of 250 pF, R is approximately 100 kΩ. At 5 mA, this provides another 500 V drop, so that the output voltage at the deflector is 102.5 kV; thus for a deflector voltage of 120 kV, the peak ac input voltage to the Cockcroft-Walton must be

$$V_0' = \frac{120}{102.5} \times 10^4 = 11.7 \text{ kV.} \quad (3)$$

FOOTNOTES AND REFERENCES

* This work was done under the auspices of the U. S. Atomic Energy Commission.

1. Ferdinand Voelker, Lawrence Radiation Laboratory Engineering Note EE-304, November 5, 1954.

This report was prepared as an account of Government sponsored work. Neither the United States, nor the Commission, nor any person acting on behalf of the Commission:

- A. Makes any warranty or representation, expressed or implied, with respect to the accuracy, completeness, or usefulness of the information contained in this report, or that the use of any information, apparatus, method, or process disclosed in this report may not infringe privately owned rights; or
- B. Assumes any liabilities with respect to the use of, or for damages resulting from the use of any information, apparatus, method, or process disclosed in this report.

As used in the above, "person acting on behalf of the Commission" includes any employee or contractor of the Commission, or employee of such contractor, to the extent that such employee or contractor of the Commission, or employee of such contractor prepares, disseminates, or provides access to, any information pursuant to his employment or contract with the Commission, or his employment with such contractor.

