

# Lawrence Berkeley National Laboratory

## Recent Work

### Title

INSERTION DEVICES FOR THE ADVANCED LIGHT SOURCE AT LBL

### Permalink

<https://escholarship.org/uc/item/20n2g8n7>

### Authors

Hassenzahl, W.

Chin, J.

Halbach, K.

### Publication Date

1989-03-01

2



# Lawrence Berkeley Laboratory

UNIVERSITY OF CALIFORNIA

## Accelerator & Fusion Research Division

Presented at the 1989 IEEE Particle Accelerator Conference  
Chicago, IL, March 20-23, 1989

RECEIVED  
LAWRENCE  
BERKELEY LABORATORY

DEC 12 1989

### Insertion Devices for the Advanced Light Source at LBL

LIBRARY AND  
DOCUMENTS SECTION

W. Hassenzahl, J. Chin, K. Halbach, E. Hoyer, D. Humphries,  
B. Kincaid, and R. Savoy

March 1989

**TWO-WEEK LOAN COPY**  
*This is a Library Circulating Copy  
which may be borrowed for two weeks.*

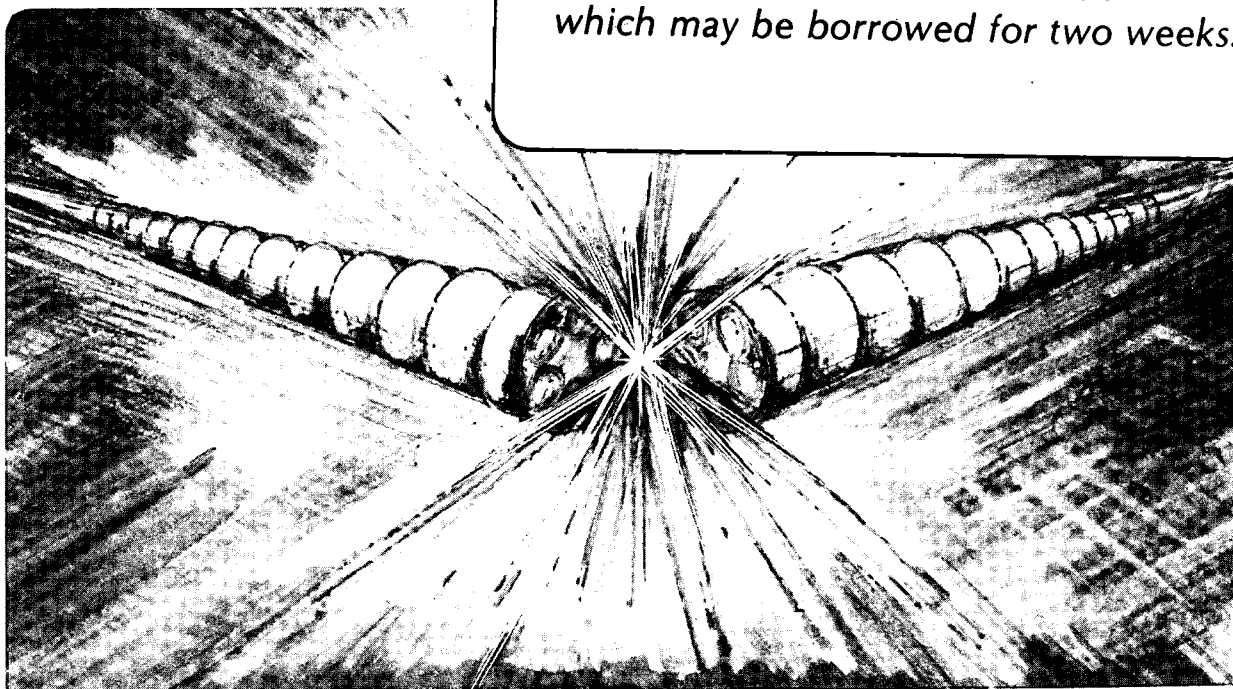

LBL-25992  
2

## **DISCLAIMER**

This document was prepared as an account of work sponsored by the United States Government. While this document is believed to contain correct information, neither the United States Government nor any agency thereof, nor the Regents of the University of California, nor any of their employees, makes any warranty, express or implied, or assumes any legal responsibility for the accuracy, completeness, or usefulness of any information, apparatus, product, or process disclosed, or represents that its use would not infringe privately owned rights. Reference herein to any specific commercial product, process, or service by its trade name, trademark, manufacturer, or otherwise, does not necessarily constitute or imply its endorsement, recommendation, or favoring by the United States Government or any agency thereof, or the Regents of the University of California. The views and opinions of authors expressed herein do not necessarily state or reflect those of the United States Government or any agency thereof or the Regents of the University of California.

# Insertion Devices for the Advanced Light Source at LBL

William Hassenzahl, John Chin, Klaus Halbach, Egon Hoyer, Donald Humphries,  
Brian Kincaid, and Roland Savoy

Accelerator and Fusion Research Division  
Lawrence Berkeley Laboratory  
1 Cyclotron Road  
Berkeley, California 94720

Paper presented at the 1989 Particle Accelerator Conference in Chicago, Illinois,  
March 20 to 23, 1989

This work was supported by the Director, Office of Energy Research, Office of Basic Energy Sciences,  
Materials Sciences Division of the U. S. Department of Energy under Contract No. DE-AC03-  
76SF00098

Abstract

Table I U5.0 Parameters

The Advanced Light Source (ALS) at the Lawrence Berkeley Laboratory will be the first of the new generation of dedicated synchrotron light sources to be put into operation. Specially designed insertion devices will be required to realize the high brightness photon beams made possible by the low emittance of the electron beam. The complement of insertion devices on the ALS will include undulators with periods as short as 3.9 cm and one or more high field wigglers. The first device to be designed is a 5 m long, 5 cm period, hybrid undulator. The goal of very high brightness and high harmonic output imposes unusually tight tolerances on the magnetic field quality and thus on the mechanical structure. The design process, using a generic structure for all undulators, is described.

Period	5.0 cm
Overall Length	5.0 m
Number of Periods	98
Number of Poles	197
End Sequence	-1/2 +1
Maximum Operation Field	0.9 T
Minimum Operational Gap	1.4 cm
Usable Spectral Harmonics	1st, 3rd, & 5th
Pole Height	11 cm
Pole Width	8 cm
# of Blocks per half period	6
Block Material	Nd-Fe
Gap Variation - Single Pole	50 microns
Gap Variation - Systematic	20 microns
Single Pole Tilt	0.2 mrad
Pole Thickness	0.88 cm
Pole Thickness Variation	50 microns
Block Easy axis orientation	+/- 1.6 degrees

Introduction

The Advanced Light Source project at the Lawrence Berkeley Laboratory is scheduled for completion in 1993. Based on input from the user community through a series of workshops and by letters of interest, we are designing a set of insertion devices (IDs) and associated beam lines that span the spectral range accessible to the ALS. The first devices will have periods of 3.9, 5.0, 8.0, and 13.6 cm. The first three are undulators and will be 5.0 m long; the 13.6 cm period ID will be a wiggler with a length of 2.5 m.

The intent is to have the major structural components of these devices be identical, resulting in a "generic device", as shown in Fig. 1. The first device to be designed and constructed will be the 5.0 cm period undulator, U5.0. This device was chosen because it can operate near maximum performance at the commissioning gap, which will be 2.4 cm. The support structure, backing beam, and positioning system are all designed to function comfortably with a maximum magnetic load of 38,000 kg.

Parameters of U5.0

Some parameters and tolerances for the first ID, U5.0, are given in Table I. These characteristics were established to fully utilize the potential of the ALS. Each tolerance in the table is set by a calculation of its effect on spectral performance. For example, systematic variations of K along the length of the ID, such as those produced by magnetic loading, will cause spectral broadening. This effect on the width of a spectral harmonic can be determined from the intrinsic or mean width and the effect of errors. Expressing all errors in %, the spectral width is given by:

$$\sigma_{\text{int}} = (\sigma_{\text{int}}^2 + \sigma_{\text{err}}^2)^{1/2}$$

The intrinsic width consists of contributions from the insertion device and the electron beam's divergence and momentum spread.

$$\sigma_{\text{int}} = (\sigma_{\Delta p}^2 + \sigma_{\Delta \phi}^2 + (\frac{1}{2.3nN})^2)^{1/2}$$

where n is the harmonic number, N is the number of periods, and the factor of 2.3 converts from FWHM to rms width. Using the 5th harmonic line width as a reference point, the allowable gap variation due to magnetic loading is found to be 20 μm when  $\sigma_{\text{err}} = \sigma_{\text{int}}$ .

The random errors in the pole and block placement and variations in the characteristics of the neodymium-iron (Nd-Fe) blocks also affect spectral performance. The collective effect of all errors is established to limit degradation to less than 3 db, i.e., spectral brilliance will be at least 70 % of that expected from a device with no errors.

Magnetic Structure

The U5.0 will use a hybrid magnetic configuration consisting of Nd-Fe magnetic blocks and vanadium permendur poles. The hybrid is chosen because of several advantages over the pure current sheet equivalent material (CSEM) design.

- The field is dominated by the characteristics of the poles, which can be made very uniform both in size and magnetic performance.
- The errors in magnetic moments of the blocks can be averaged by sorting the blocks for the poles.
- Errors in the total magnetic moment of all the blocks on a pole have little effect on the electron beam or the spectrum because they contribute equally to adjacent poles and produce no electron beam steering.
- The peak field at each pole can be tuned by a small amount.
- A higher peak field is achievable.

Analysis of Existing Insertion Devices

To aid in the establishment of an error tolerance on the U5.0 we have reviewed some of the data on three insertion devices, the beam line 6 (BL VI) and beam line 10 (BL X) devices at the SSRL (1-3), and the TOK device at the NSLS (4). One of the significant results from this analysis is that the major field errors are in the region between the poles. This can be seen in Fig. 2, which shows the residual magnetic field errors along the axial direction after the allowed spatial harmonics are removed using nonlinear least squares fitting. The dashed lines show the centers of the poles. The source of these errors is not completely known at present, but several possibilities have been explored. These include: misalignment of the magnetic moment of one or more blocks, which would lead to a magnetic charge sheet on the surface facing the electron beam; a mismatch between adjacent blocks, which would lead to a vertical sheet of magnetic charge directly above the electron beam; and a vertical misalignment of the blocks, which would lead to an intense but narrow charge sheet just above the electron beam.

In addition to the analysis of these devices, the effect of selectively pairing pole assemblies with known field deviations has been studied. The TOK wiggler, as initially assembled, had random field errors in pole field strength of about 0.5%. By selectively pairing poles with high or low strengths the effective error was reduced, yielding an effective error of about 0.1% based on calculated electron trajectory and calculated and observed spectral performance.

\* This work was supported by the Director, Office of Energy Research, Office of Basic Energy Sciences, Materials Sciences Division, of the U.S. D.O.E., under Contract No. DE-AC03-76SF00098.

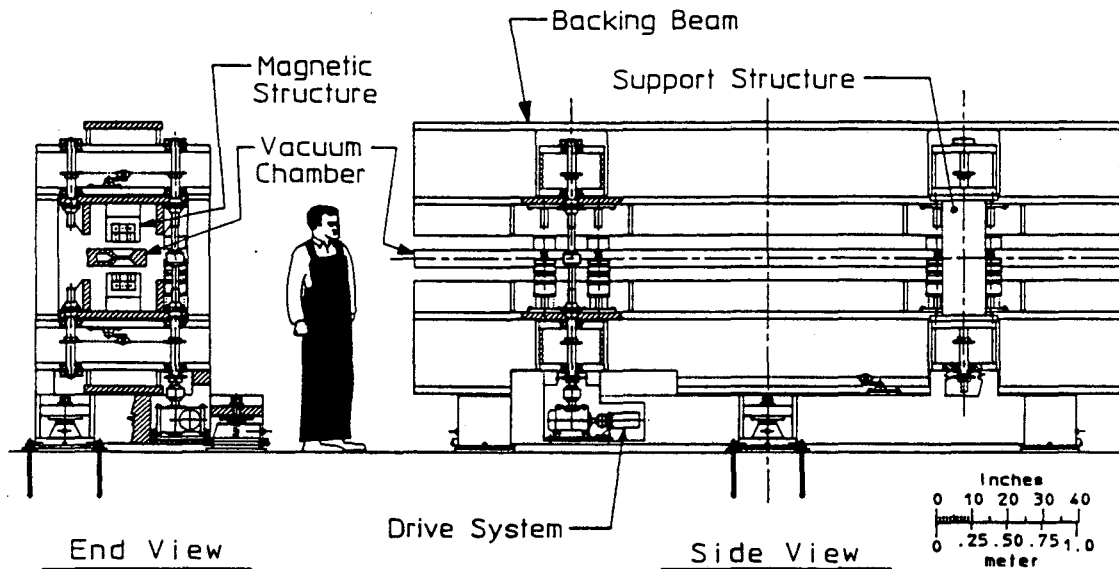

Fig. 1. The generic mechanical structure for the LBL Advanced Light Source insertion Devices. The Structure is 5.0 m long and is designed to accommodate magnetic loads up to 38,000 kg with acceptable deflections.

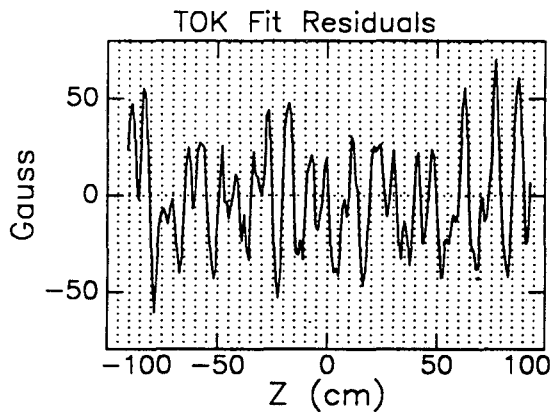

Fig. 2. Magnetic field residuals in the Transverse Optical Klystron at the NSLS. These are the fields that remain after removing spatial harmonics determined in a non linear least squares Fourier analysis of the field. The dotted lines show the centers of the poles. The field errors tend to be greater in the regions between poles than on the poles.

#### Magnetic Configuration

The periodic magnetic structure consisting of Nd-Fe blocks and vanadium permendur poles that is proposed for U5.0 is shown in Fig. 3. The configuration consists of a rectangular pole and an array of 6 Nd-Fe blocks. The principal objective of the design effort was to develop a magnetically well behaved structure that maximizes  $B_{ms}$  (as defined below) for midplane fields. The design approach utilizes Halbach's three dimensional (3-D) Hybrid Theory and two dimensional (2-D) modeling with PANDIRA(5).

PANDIRA allows convenient 2-D modeling of anisotropic materials. These materials are defined by the remanent and coercive field intercepts of the linear B-H curve associated with the Nd-Fe along with its easy axis orientation angle. The vanadium permendur is described by a non-linear B-H curve based on measured data.

The 2-D models are used to optimize the pole thickness, to provide detailed information about magnetic behavior, and to provide flux information for the 3-D calculation. The transverse width of the pole is determined by external considerations such as limits on  $dB_y/dx$ , ( $x$  is the transverse - horizontal direction) and scaling from other devices. The set back of the Nd-Fe above the pole face is determined by vacuum chamber and assembly tolerance constraints.

To perform the 3-D calculation, pole flux is separated into a direct and an indirect flux, which are further separated into uniform and non-uniform components. The direct flux comes from the Nd-Fe and establishes the pole's scalar potential. The indirect flux, which can be calculated, results from this scalar potential and is composed of contributions from all surfaces of the pole.

An overhang of Nd-Fe at the top and sides of the pole is used to achieve desired performance and to optimize the quantity of Nd-Fe used in the structure. This overhang contributes to the 'direct' flux and causes an increase in the scalar potential of the pole. The final dimensions result from balancing the direct and indirect fluxes, where overhang dimensions and pole height are adjusted to achieve desired performance with a minimal volume of Nd-Fe.

The spatial harmonics in the fields at the midplane, in the region of the electron beam, are examined by expressing the field in a Fourier series, where the periodic structure is assumed to be infinitely long and wide. The appropriate expression containing only those components allowed by symmetry is:

$$B(z) = \sum_{i=1}^{\infty} b_{2i+1} \cos\{(2i+1)kz\} \cosh\{(2i+1)ky\}$$

Where  $k = 2\pi/\lambda_u$ ,  $\lambda_u$  is the undulator period, and  $b_{2i+1} = B_{2i+1}/B_1$  is the normalized amplitude of the  $2i+1$  field component,  $B_1$  is the amplitude of the fundamental. The value of  $B_{ms}$  that is maximized to achieve peak performance is defined as:

$$B_{ms}^2 = \sum_{i=1}^{\infty} (B_{2i+1}/(2i+1))^2 = B_1^2 \sum_{i=1}^{\infty} (b_{2i+1}/(2i+1))^2$$

For  $\lambda_u = 5.0$  cm the third harmonic ( $b_3$ ) at the midplane for a pole thickness of 8.8 mm is less than 5% of the fundamental and higher harmonics are negligible,  $b_5 < 1\%$  and  $b_7 < 0.25\%$ . The percentage of third harmonic is maximum at the design gap of 1.4 cm and decreases as the gap increases. This harmonic could be reduced slightly if it were not necessary to have a 1 mm chamfer, which is included to reduce the effects of saturation.

#### Insertion Device Mechanical Design

Figure 1 shows the major subsystems, magnetic structure, support structure, drive system, and vacuum system for the proposed 5 m long U5.0. The design philosophy for the initial complement of insertion devices is toward a generic insertion device design to reduce engineering and fabrication costs and for easier maintainability. Undulator and wiggler components that will be similar include the backing beams, support structures, drive systems, vacuum chambers, and pumping systems.

## Magnetic Structure

Figures 1 and 3 show the proposed U5.0 magnetic structure, which includes:

- Half period pole assemblies consisting of an aluminum keeper, a vanadium permendur pole (8 cm wide x 12 cm high x 0.88 cm thick), Nd-Fe blocks (6.8 cm x 3.87 cm x 1.62cm in the orientation direction). Pole assembly fabrication is planned to be similar to that used on the BL VI and BL X wiggler poles(1,2).
- Pole assembly mounts fabricated from jig plate aluminum for mounting and accurately positioning approximately 20 pole assemblies each. Each pole assembly mount is in turn kinematically mounted onto a backing beam.
- Steel backing beams hold the magnetic structure components and provide magnetic shielding. These 5 m long beams (2.5 m for the wiggler) are rigid, with a deep, 81 cm, web and a 89 cm wide flange to minimize systematic gap variations, which cause a loss in spectral performance.
- Sets of rotators, for nulling the field integral, similar to those used on the BL VI undulator, are planned.(3)
- Tuning studs and auxiliary coils have been considered and will be designed and implemented if required.

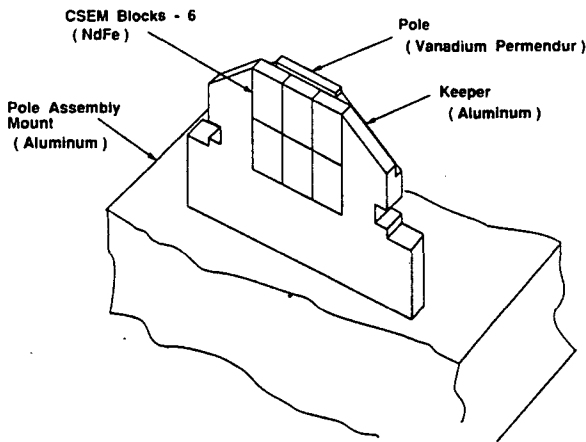

Fig. 3. The pole assembly for the U5.0 insertion device. Shown are the Vanadium Permendur pole, the six Nd-Fe blocks, and the aluminum keeper as attached to the Assembly mount.

## Support Structure

Two types of support structure, 4-post and C-frame, were evaluated in the process of designing the U5.0. The 4-post support structure was selected because of the following advantages:

- Greater tunnel walkway clearance.
- Less gap deflection due to a more rigid structure.
- No pole rotation (tilt) due to symmetrical loading.
- Better access for assembly of components.

Advantages of the C-frame included easier vacuum chamber installation and the possibility of using external magnetic measurement equipment.

The 4-post design consists of a rigid base with: 3 kinematic floor mounts and alignment assemblies, 4 horizontal members that pass through the 2 backing beams, and 4 vertical posts. This modular design provides for easy assembly and future servicing. The 4 horizontal members pass through the backing beams, which allows the structure to fit within a 2.4 m high tunnel.

## Drive System

The drive system, which will be computer controlled, consists of a motor, a drive train, an absolute encoder and a controller with digital readout. The motor in the drive train drives a 30:1 reduction worm-gear box and eight 2 mm pitch lead screws, which are driven as a synchronous unit with a roller-chain system. Planned system

capability includes a minimum incremental motion of the magnetic gap of 0.1 microns, maximum gap motion of 2 mm/second, and opening to full gap, 21.6 cm, in less than 2 minutes. To enhance the responsiveness of the drive system to small motions, a nonlinear compensating spring system has been designed to follow the variation in magnetic load with gap. This design consists of several sets of different sizes of belleville washers and a compression coil spring stacked together into one assembly.

## Vacuum System

The vacuum chamber design, Fig. 4, shows a rigid, two-piece, welded chamber of either 5083 H321 Aluminum or 316 L SS, similar in construction to the BL X vacuum chamber. Material selection will be determined on the basis of achievable fabrication tolerances, radiation shielding effectiveness for the permanent magnet material, and fabrication method of the clearing electrode. Chamber internal dimensions are a vertical aperture of 10 mm and horizontal aperture of 217 mm. The design allows for a minimum magnet gap of 14 mm (15 mm if clearing electrodes are required) through the use of thin sections, 0.75 mm thick, at the pole locations. The horizontal aperture is large to allow the bend magnet radiation to pass through the insertion device region and be absorbed downstream. The enlarged chamber area will aid horizontal vacuum conductance.

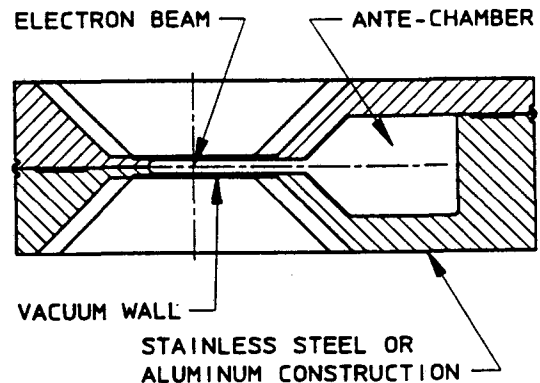

Fig. 4. The vacuum chamber for the U5.0.

## References

- [1] E. Hoyer et al., The Beam Line VI REC-Hybrid Wiggler For SSRL, IEEE Trans. NS-30, 3118, (1983).
- [2] E. Hoyer, et al., The Beam Line X Nd-Fe-Steel Hybrid Wiggler For SSRL, IEEE Catalog No. 87 CH 2387-9, 1508 (1987)
- [3] K. Halbach et al., A Permanent Magnet Undulator For Spear, IEEE Trans. Nucl. Sci., NS-28, 3136 (1981).
- [4] R.R. Freeman and B.M. Kincaid, "Production of Coherent XUV and Soft X-rays Using a Transverse Optical Klystron," Laser Techniques in the Extreme Ultraviolet, S.E. Harris and T.B. Lucatorto, eds. (Am. Inst. of Physics, New York, 1984).
- [5] PANDIRA is an improved version of POISSON, which allows solution of permanent magnet and residual field problems. POISSON in turn is an improved version of TRIM (A. M. Winslow, J. Computer Phys. 1, 149, (1967)), developed by K. Halbach et al.

LAWRENCE BERKELEY LABORATORY  
TECHNICAL INFORMATION DEPARTMENT  
1 CYCLOTRON ROAD  
BERKELEY, CALIFORNIA 94720